



Configuring MPLS Layer 2 VPNs

First Published: March 29, 2012

Last Revised:

The Frame Relay to ATM Bridged Interworking feature provides interoperability between the Frame Relay attachment virtual circuit (VC) and the ATM attachment VC that are connected to different provider edge (PE) routers. The bridged encapsulation corresponding to the bridged (Ethernet) interworking mechanism is used to enable this interoperability. The Ethernet frames are carried through the MPLS network using Ethernet over MPLS (EoMPLS). The interworking function is performed in the PE routers connected to the Frame Relay attachment VC and the ATM attachment VC based on RFC 2684 and RFC 2427.

The xconnect support on Gigabit EtherChannel (GEC) Virtual Private Wire Service (VPWS) on ASR 1000 feature enables service providers to supply connectivity between customer sites with existing data link layer (Layer 2) networks by using a single, integrated, packet-based network infrastructure—a Cisco MPLS network. Instead of separate networks with separate network management environments, service providers can deliver Layer 2 connections over an MPLS backbone.

Layer 2 Gateway Protocol (L2GP) is a recommended IEEE standard (802.1ah) to address the issues that arise when two independent, bridged domains are connected redundantly through an arbitrary number of links. L2GP defines how the forwarding gateways are selected, so that only redundant ports are blocked and there are no temporary loops. The transition should be at least at the same speed in which Spanning Tree Protocol (STP) L2GP resolves the transient loop problem during reconvergence because it does not require cooperation from the outside domain.

Reverse Layer 2 Gateway Protocol (R-L2GP) is a variation of an L2GP. In case of an R-L2GP, the pseudo information of the R-L2GP is transmitted by network provider edges (nPEs) instead of user provider edges (uPEs). R-L2GP provides a mechanism to send out static preconfigured bridge protocol data units (BPDUs) on each ring access port of the nPEs to stimulate a per-access ring instantiation of the protocol. R-L2GP enables the PEs to avoid the burden of running Multiple Instances Spanning Tree Protocol (MISTP) when multiple independent access networks that run MISTP connect to a pair of redundant PEs.

High-Level Data Link Control (HDLC) Ethernet over MPLS is part of the Any Transport over MPLS (AToM) solution. HDLC and Ethernet are two link-layer transports that utilize the AToM architecture.

- [Overview of L2VPN Interworking, on page 2](#)
- [Virtual Private LAN Services, on page 4](#)
- [Prerequisites for Frame Relay DLCI-to-ATM AAL5SNAP Bridged Interworking, on page 11](#)
- [Frame Relay DLCI-to-ATM AAL5SNAP Bridged Interworking, on page 11](#)
- [Configuring Frame Relay DLCI-to-ATM AAL5SNAP Bridged Interworking, on page 13](#)
- [Gigabit EtherChannel for Virtual Private Wire Service, on page 19](#)

- [Configuring Gigabit EtherChannel for Virtual Private Wire Service](#), on page 20
- [High-Level Data Link Control-Ethernet Interworking](#), on page 31
- [Configuring HDLC-Ethernet Interworking](#), on page 32
- [Additional References](#), on page 58
- [Technical Assistance](#), on page 60
- [Feature Information for Configuring MPLS Layer 2 VPNs](#), on page 60
- [Glossary](#), on page 62

Overview of L2VPN Interworking

Interworking is a transforming function that interconnects two heterogeneous attachment circuits (ACs). Several types of interworking functions exist. The function that is used depends on the AC type used, the type of data carried, and the level of functionality required. The two main Layer 2 Virtual Private Network (L2VPN) interworking functions supported in Cisco IOS XE software are bridged interworking and routed interworking.

Layer 2 (L2) transport over multiprotocol label switching (MPLS) and IP exists for ACs, such as Ethernet-to-Ethernet or Point-to-Point Protocol (PPP), Ethernet to VLAN, and Ethernet to Frame Relay. An interworking function facilitates translation between different L2 encapsulations.

L2VPN Interworking Modes

L2VPN interworking works in either Ethernet (bridged) mode or IP (routed) mode. You can specify the mode by issuing the **interworking {ethernet | ip}** command in pseudowire-class configuration mode and in L2VPN xconnect configuration mode for protocol-based CLI.

The **interworking** command causes the ACs to be terminated locally. The two keywords perform the following functions:

- The **ethernet** keyword causes Ethernet frames to be extracted from an AC and sent over the pseudowire. Ethernet end-to-end transmission is resumed. The AC frames that are not Ethernet are dropped. In the case of VLAN, the VLAN tag is removed, leaving an untagged Ethernet frame.
- The **ip** keyword causes IP packets to be extracted from an AC and sent over the pseudowire. The AC frames that do not contain IPv4 packets are dropped.

The following sections explain the Ethernet and IP interworking modes in detail.

Ethernet or Bridged Interworking

Ethernet interworking is also called bridged interworking. Ethernet frames are bridged across the pseudowire. The CE routers can natively bridge Ethernet traffic or can route traffic using a bridged encapsulation model, such as Bridge-group Virtual Interface (BVI) or Routed Bridge Encapsulation (RBE). The PE routers operate in the Ethernet like-to-like mode.

The Ethernet interworking mode offers the following services:

- LAN services—An example of this is an enterprise that has several sites, with some sites having Ethernet connectivity to the service provider (SP) network and others having Asynchronous Transfer Mode (ATM) connectivity. If the enterprise requires LAN connectivity to all its sites, traffic from the Ethernet or VLAN of one site can be sent through the IP/MPLS network and encapsulated as bridged traffic over an ATM VC of another site.
- Connectivity services—An example of this is an enterprise that has different sites running an Internal Gateway Protocol (IGP) that has incompatible procedures on broadcast and non broadcast links. This

enterprise has several sites that run an IGP, such as Open Shortest Path First (OSPF) or Intermediate System-to-Intermediate System (IS-IS), between the sites. In this scenario, some of the procedures (such as route advertisement or designated router election) depend on the underlying L2 protocol and are different for a point-to-point ATM connection versus a broadcast Ethernet connection. Therefore, the bridged encapsulation over ATM can be used to achieve homogenous Ethernet connectivity between the CE routers running an IGP.

IP or Routed Interworking

IP interworking is also called routed interworking. The CE routers encapsulate the IP on the link between the CE router and the PE router. A new VC type is used to signal the IP pseudowire in MPLS. Translation between the L2 and IP encapsulations across the pseudowire is required. Special consideration needs to be given to the address resolution protocol operation and routing protocol operation, because these are handled differently on different L2 encapsulations.

The IP interworking mode is used to provide IP connectivity between sites, regardless of the L2 connectivity to these sites. It is different from a Layer 3 VPN because it is point-to-point in nature and the service provider does not maintain any routing information pertaining to customers.

Address resolution is encapsulation dependent as specified here:

- Ethernet uses Address Resolution Protocol (ARP)
- ATM uses inverse ARP
- PPP uses IP Control Protocol (IPCP)
- HDLC uses Serial Line ARP (SLARP)

Therefore, address resolution must be terminated on the PE router. Also, the end-to-end address resolution is not supported. Routing protocols operate differently over broadcast and point-to-point media. For Ethernet, the CE routers must either use static routing or configure the routing protocols to treat the Ethernet side as a point-to-point network.

In routed interworking, the IP packets that are extracted from the ACs are sent over the pseudowire. The pseudowire works in the IP Layer 2 transport (VC type 0x000B) like-to-like mode. The interworking function at the network service provider's (NSP) end completes the required adaptation based on the AC technology. The non-IPv4 packets are dropped.

In routed interworking, the following considerations must be kept in mind:

- ARP, inverse ARP, and IPCP are punted to the routing protocol.

Therefore, the PE router at the NSP end must provide the following address-resolution functionalities for the Ethernet and ATM and Frame Relay point-to-point subinterface attachment circuits:

- Ethernet—The PE device acts as a Proxy ARP server to all the ARP requests from the CE router. The PE router responds with the MAC address of its local interface.
- ATM and Frame Relay point-to-point subinterface—By default, inverse ARP does not run in the point-to-point Frame Relay or ATM subinterfaces. The IP address and subnet mask define the connected prefix; therefore, configuration is not required in the CE devices.
- Interworking requires that the MTUs in both the ACs must match for the pseudowire that is to come up. The default MTU in one AC must match the MTU of other AC.

The following table lists the range of MTUs that can be configured for different ACs.

Table 1: Range of MTUs for Different ACs

AC Type	Range of MTUs Supported
ATM	64 to 9216
Gigabit Ethernet	1500 to 9216
POS	64 to 9216
Fast Ethernet	1500 to 9216

The MTU configured on an AC must not exceed the MTU in the core network. This ensures that the traffic is not fragmented.

- The CE routers with Ethernet attachment VCs running OSPF must be configured with the *ospfIfType* option so that the OSPF protocol treats the underlying physical broadcast link as a P2P link.

Virtual Private LAN Services

Virtual Private LAN Service (VPLS) enables enterprises to link together their Ethernet-based LANs from multiple sites via the infrastructure provided by their service provider. From the enterprise perspective, the service provider's public network looks like one giant Ethernet LAN. For the service provider, VPLS provides an opportunity to deploy another revenue-generating service on top of their existing network without major capital expenditures. Operators can extend the operational life of equipment in their network.

Virtual Private LAN Services (VPLS) uses the provider core to join multiple attachment circuits together to simulate a virtual bridge that connects the multiple attachment circuits together. From a customer point of view, there is no topology for VPLS. All of the CE devices appear to connect to a logical bridge emulated by the provider core.

Reverse Layer 2 Gateway Protocol

Layer 2 Gateway Protocol (L2GP) is a recommended IEEE standard (802.1ah) to address the issues that arise when two independent, bridged domains are connected redundantly through an arbitrary number of links. L2GP defines how the forwarding gateways are selected, so that only redundant ports are blocked and there are no temporary loops. The transition should be at least the same speed in which STP L2GP resolves the transient loop problem during the reconvergence because it does not require cooperation from the outside domain.

Reverse Layer 2 Gateway Protocol (R-L2GP) is a variation of an L2GP. In case of an R-L2GP, the pseudo information of the R-L2GP is transmitted by Network-facing Provider Edges (nPEs) instead of User Provider-Edges (uPEs). R-L2GP provides a mechanism to send out static preconfigured Bridge Protocol Data Units (BPDUs) on each ring access port of nPEs to stimulate a per-access ring instantiation of the protocol. R-L2GP enables the Provider Edges (PEs) to avoid the burden of running Multiple Instance Spanning Tree Protocol (MST) when multiple independent access networks that run MST connect to a pair of redundant PEs.

In order for this to work, the pair of nPEs are programmed to send out BPDUs on the access ring ports in such a way that they appear to be either:

- The root bridge itself (the bridge with the lowest bridge ID or priority).
- The bridge with the second lowest bridge ID or priority, and with a 0 cost path to the root.

Using R-L2GP, you can statically configure the BPDUs instead of the STP generate the BPDUs dynamically. The following figure shows the topology of multiple-access networks connected to redundant nPEs.

Figure 1: Multiple-Access Networks Connected to Redundant nPEs

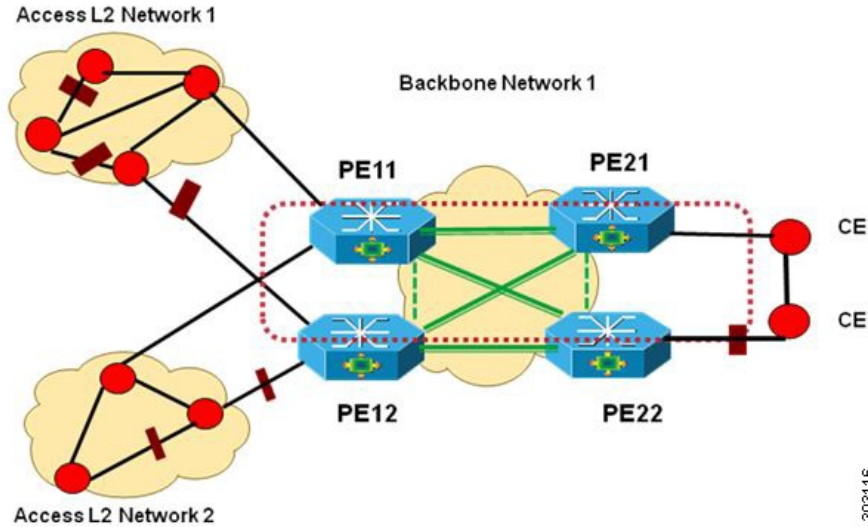

303116

BPDUs Sent Out of R-L2GP Ports

An R-L2GP module in a route processor (RP) generates static preconfigured BPDUs, and sends them to uPEs via access ports, with the R-L2GP enabled.



Note Only locally generated static BPDUs can be sent out to RL2GP ports.

The following figure shows how a BPDU is forwarded to an R-L2GP port.

Figure 2: BPDU on an R-L2GP Port

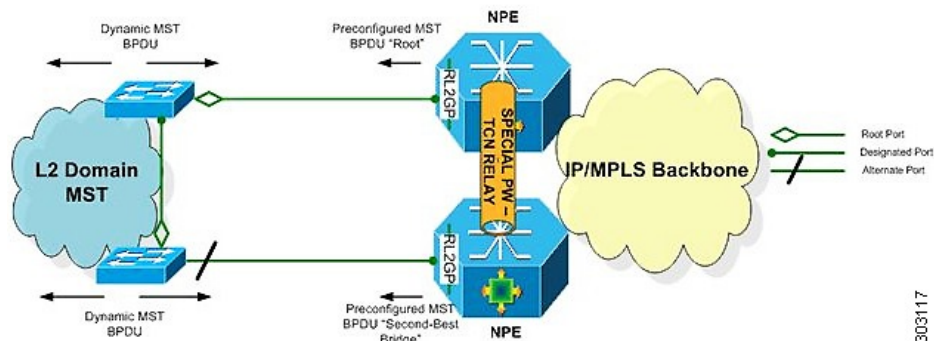

303117

BPDUs Received on R-L2GP Ports

On PE, only BPDUs with Topology Change Notification (TCN) bits on are punted to the R-L2GP and the STP module. If the PE is in a redundant setting, the corresponding BPDUs are propagated to peer-redundant PE via the L2 protocol forwarding pseudowire (PW).

BPDUs Received on L2 Protocol Forwarding PW

The TCN BPDUs received from L2 protocol forwarding PW are punted to RP, and STP/R-L2GP process it and generate MAC flush.

Restrictions for R-L2GP

The restrictions for the R-L2GP feature are:

- R-L2GP is supported only on L2 bridge ports, and is not compatible with prestandard MST.
- All the access-side shall have the same MST instance, the same name and the same revision number configuration as nPEs.
- There is no configure error detection and recover mechanism for R-L2GP. Users are expected to configure R-L2GP and MSTP instance on CEs and nPEs correctly.

Configuring the R-L2GP

Since the R-L2GP configuration is bundled with the MST configuration, the above parameters can be recycled from the MSTI and MST region (currently only one MST region is supported on IOS) configurations. This section describes how to configure Reverse L2GP. It consists of the following sections:

Configuring the MST

Configuration of the MST must be done before configuring the R-L2GP and attaching the R-L2GP to a port.

SUMMARY STEPS

1. **enable**
2. **configure terminal**
3. **spanning-tree mode mst**
4. **spanning-tree mst configuration**
5. **name name**
6. **revision version**
7. **instance instance-id {vlans vlan-range}**

DETAILED STEPS

	Command or Action	Purpose
Step 1	enable Example: Router# enable	Enables privileged EXEC mode. Enter your password if prompted.

	Command or Action	Purpose
Step 2	configure terminal Example: <pre>Router# configure terminal</pre>	Enters global configuration mode.
Step 3	spanning-tree mode mst Example: <pre>Router(config)# spanning-tree mode mst.</pre>	Enables MST mode.
Step 4	spanning-tree mst configuration Example: <pre>Router(config)# spanning-tree mst configuration</pre>	Enters MST configuration submode.
Step 5	name name Example: <pre>Router(config-mst)# name Cisco</pre>	Sets the name of the MST region. Note All the nodes in the same region should be configured with the same MST name.
Step 6	revision version Example: <pre>Router(config-mst)# revision 5</pre>	Sets the revision number for the MST (802.1s) configuration. Note All the nodes in the same region should be configured with the same MST configure revision number.
Step 7	instance instance-id {vlans vlan-range} Example: <pre>Router(config-mst)# instance 2 vlans 1-100</pre>	Maps a VLAN or a group of VLANs to an MST instance.

Configuring an R-L2GP Instance

Perform the following steps to configure R-L2GP instance.

SUMMARY STEPS

1. **enable**
2. **configure terminal**
3. **spanning-tree pseudo-information transmit identifier**
4. **remote-id id**
5. **mst region-id root mac-address**
6. **mst region-id cost**

DETAILED STEPS

	Command or Action	Purpose
Step 1	enable Example: Router> enable	Enables privileged EXEC mode. Enter your password, if prompted.
Step 2	configure terminal Example: Router# configure terminal	Enters global configuration mode.
Step 3	spanning-tree pseudo-information transmit identifier Example: Router(config)# <i>spanning-tree pseudo-information transmit 46</i>	Configures the Reverse-L2GP configuration on the interface or the untagged Ethernet Flow Point (EFP) port.
Step 4	remote-id id Example: Router(config-pseudo)# <i>remote-id 53</i>	Configures the remote R-L2GP instance ID that pairs with the specified R-L2GP instance ID.
Step 5	mst region-id root mac-address Example: Router(config-pseudo)# <i>mst 0 root 32768 0000.0000.0001</i>	Adds MST instances to R-L2GP instances and configures the MAC address and priority for MST instances. Note MST 0 has all the VLANs that have not been explicitly specified in other MST instances. MST 0 must be configured for each R-L2GP instance.
Step 6	mst region-id cost Example: Router(config-pseudo)# <i>mst 1 cost 1</i>	Adds the corresponding MST instance list to the R-L2GP instance and configures the R-L2GP path cost for the MST instance or multiple MST instances.

What to do next



Note To configure an R-L2GP on the Cisco ASR 1000 Series Aggregation Services Router, the remote-id configured on nPE1 must be the transmit identifier configured on nPE2, and vice versa.

Attaching an R-L2GP Instance to a Port

SUMMARY STEPS

1. **enable**
2. **configure terminal**

3. interface gigabitethernet slot/port
4. spanning-tree pseudo-information transmit identifier

DETAILED STEPS

	Command or Action	Purpose
Step 1	<p>enable</p> <p>Example:</p> <pre>Router> enable</pre>	<p>Enables privileged EXEC mode.</p> <p>Enter your password, if prompted.</p>
Step 2	<p>configure terminal</p> <p>Example:</p> <pre>Router# configure terminal</pre>	<p>Enters global configuration mode.</p>
Step 3	<p>interface gigabitethernet slot/port</p> <p>Example:</p> <p>or</p> <p>Example:</p> <pre>interface tengigabitethernet slot/port</pre> <p>Example:</p> <pre>Router(config)# interface gigabitethernet 4/1</pre>	<p>Specifies Gigabit Ethernet or the 10 Gigabit Ethernet interface on the access side of the nPE to configure.</p> <p>Here:</p> <ul style="list-style-type: none"> • slot/port—Specifies the location of the interface.
Step 4	<p>spanning-tree pseudo-information transmit identifier</p> <p>Example:</p> <pre>Router(config-if)# spanning-tree pseudo-information transmit 46</pre>	<p>Configures the Reverse-L2GP configuration on the interface.</p> <p>Note The identifier should be the same as the one configured on the nPE.</p>

Example: Configuring an R-L2GP

The following example shows how to configure an R-L2GP in a network comprising two nPEs.

Configuration example on nPE1:

```
enable
configure terminal
spanning-tree pseudo-information transmit 46
  remote-id 53
  mst 0 root 32768 0000.0000.0001
  mst 1 root 32768 0000.0000.0002
  mst 1 cost 1
  mst 2 root 32768 0000.0000.0003
exit
interface gigabitEthernet 2/1/0
  spanning-tree pseudo-information transmit 46
```

Configuration example on nPE2:

```

spanning-tree pseudo-information transmit 53
  remote-id 46
  mst 0 root 32768 0000.0000.0001
  mst 1 root 32768 0000.0000.0002
  mst 1 cost 1
  mst 2 root 32768 0000.0000.0003
interface gigabitEthernet 0/0/1
  spanning-tree pseudo-information transmit 53

```

Configuring the Layer 2 Protocol Forwarding Virtual Private LAN Services Pseudowire Between Two Redundant NPES

SUMMARY STEPS

1. **enable**
2. **configure terminal**
3. **l2 vfi vfi-name manual**
4. **vpn id vpn_id**
5. **bridge-domain bridge_id**
6. **forward permit l2protocol all**
7. **neighbor ip-address vc-id {encapsulation mpls |pw-class pw-class-name}**

DETAILED STEPS

	Command or Action	Purpose
Step 1	enable Example: Router> enable	Enables privileged EXEC mode. Enter your password, if prompted.
Step 2	configure terminal Example: Router# configure terminal	Enters global configuration mode.
Step 3	l2 vfi vfi-name manual Example: Router(config)# l2 vfi vfitest1 manual	Creates a Layer 2 Virtual Forwarding Instance (VFI) and enters the Layer 2 VFI manual configuration submode.
Step 4	vpn id vpn_id Example: Router(config-vfi)# vpn id 303	Sets or updates a VPN ID on a VPN routing and forwarding (VRF) instance.
Step 5	bridge-domain bridge_id Example: Router(config-vfi)# bridge-domain 100	Binds a service instance to a bridge domain instance.

	Command or Action	Purpose
Step 6	forward permit l2protocol all Example: <pre>Router(config-vfi)# forward permit l2protocol all</pre>	Defines the VPLS pseudowire that is used to transport bridge protocol data unit (BPDU) information between two network provider edge (N-PE) routers.
Step 7	neighbor ip-address vc-id {encapsulation mpls pw-class pw-class-name} Example: <pre>Router(config-vfi)# neighbor 10.10.10.10 1 encapsulation mpls</pre>	Specifies the routers that should form a point-to-point Layer 2 virtual forwarding interface (VFI) connection.

Verifying an R-L2GP Configuration

The following examples show how to use the show commands to verify an R-L2GP configuration:

```
Router# show spanning-tree pseudo-information 46 configuration

remote_id 53
mst_region_id 0, port_count 2, update_flag 0x0
mrecord 0x3AF841EC, mrec_count 3:
    msti 0: root_id 32768.0000.0000.0001, root_cost 0, update_flag 0x0
    msti 1: root_id 32769.0000.0000.0002, root_cost 1, update_flag 0x0
    msti 2: root_id 32770.0000.0000.0003, root_cost 0, update_flag 0x0
Router# show spanning-tree pseudo-information 1 interface GigabitEthernet3/0/3
Pseudo id 1:
    GigabitEthernet 2/1/0
    GigabitEthernet 0/0/1
```

Prerequisites for Frame Relay DLCI-to-ATM AAL5SNAP Bridged Interworking

Before you configure the Frame Relay Data Link Connection Identifier (DLCI)-to-ATM AAL5SNAP Bridged Interworking feature on a router, ensure that the following prerequisites are met:

- Enable frame-relay switching on the Frame Relay provider edge (PE) router.
- Customer edge (CE) routers must support Bridge-group Virtual Interface or Routed Bridge Encapsulation.

Frame Relay DLCI-to-ATM AAL5SNAP Bridged Interworking

This feature provides interoperability between the ATM attachment VC and Frame Relay attachment VC connected to different PE routers. This interworking uses the bridged encapsulation corresponding to the bridged (Ethernet) interworking mechanism. The Ethernet frames are carried through the MPLS network using Ethernet over MPLS (EoMPLS). This feature is configured only in the bridged mode and not in the routed mode.

The following figure shows the interworking function performed in the PE routers that are connected to the ATM attachment VC and the Frame Relay attachment VC.

Figure 3: Network Topology for Frame Relay DLCI-to-ATM AAL5SNAP Bridged Interworking

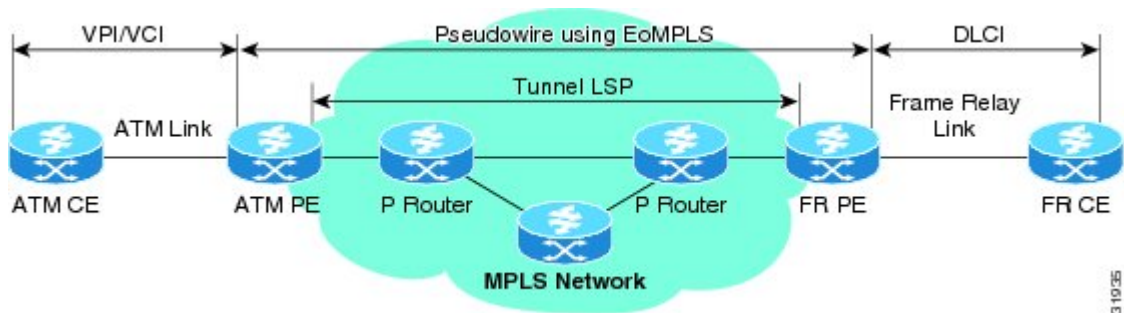

On the ATM PE router with interworking function, when traffic flows from the ATM segment to MPLS cloud, the bridged encapsulation (ATM and SNAP header) is discarded and the Ethernet frame is encapsulated with the labels required to go through the pseudowire using the VC type 5 (Ethernet). In the opposite direction, after the label disposition from the MPLS cloud, the Ethernet frames are encapsulated over AAL5SNAP using bridged encapsulation.

On the FR PE router with interworking function, when traffic flows from the FR segment to the MPLS cloud, the bridged encapsulation (Frame Relay and SNAP header) is discarded and the Ethernet frame is encapsulated with the labels required to go through the pseudowire, using the VC type 5 (Ethernet). In the opposite direction, after the label disposition from the MPLS cloud, the Ethernet frames are encapsulated over FR using bridged encapsulation.

The PE router automatically supports translation of both Cisco and IETF Frame Relay encapsulation types coming from the Customer edge (CE) router, but translates only to IETF when sending to the CE router. The Cisco CE router can handle the IETF encapsulation on receipt, even if it is configured to send Cisco encapsulation.

The following modes are supported:

- The ATM permanent virtual circuit (PVC) mode with the AAL5SNAP encapsulation type, and the existing Quality of Service (QoS) functionality for ATM PVCs.
- The Frame Relay DLCI mode, and the existing QoS functionality for Frame Relay.

PVC status signaling works the same way it does in the like-to-like case. The PE router reports the PVC status to the CE router, based on the availability of the pseudowire.

The attachment circuit maximum transmission unit (MTU) on both sides of the pseudowire must match when connected over MPLS. The non-AAL5 traffic (such as OAM cells) is punted to be processed at the RP level. A VC that is configured with OAM cell emulation on the ATM PE router (using the **oam-ac emulation-enable** command) can send end-to-end F5 loopback cells at configured intervals toward the CE router. When the pseudowire is down, an end-to-end F5 segment alarm indication signal (AIS) and remote defect indication (RDI) is sent from the PE router to the CE router.

The following figure shows the protocol stack for the Frame Relay DLCI-to-ATM AAL5SNAP Bridged Interworking feature.

Figure 4: Protocol Stack for Frame Relay DLCI-to-ATM AAL5SNAP Bridged Interworking

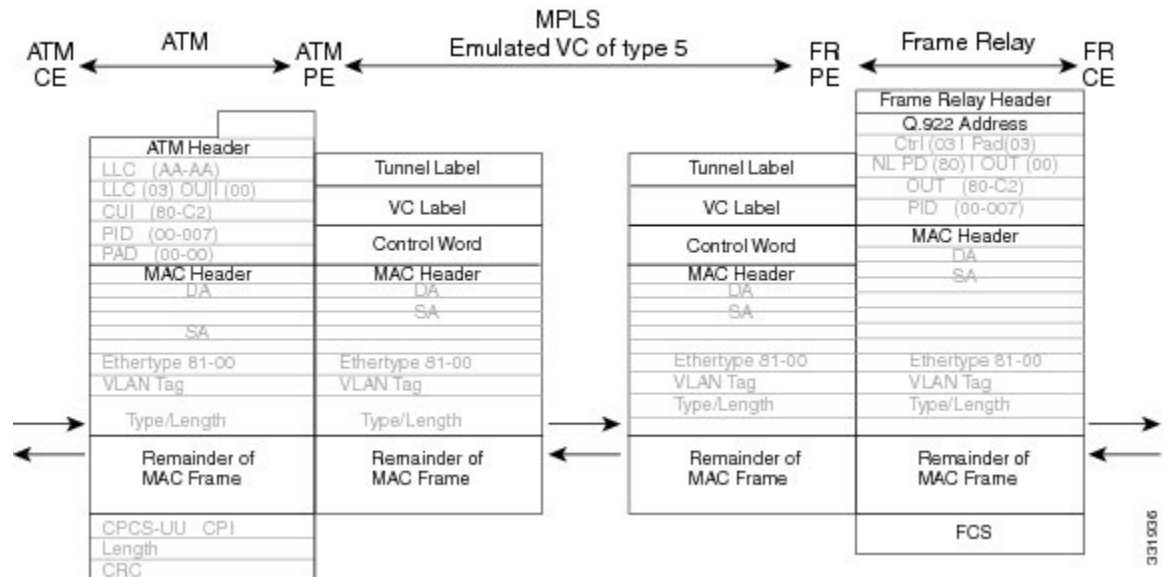

Configuring Frame Relay DLCI-to-ATM AAL5SNAP Bridged Interworking

To configure the Frame Relay DLCI-to-ATM AAL5SNAP Bridged Interworking feature on an ATM-PE router, perform the following steps:

SUMMARY STEPS

1. **enable**
2. **configure terminal**
3. **Router(config)# no ip domain lookup**
4. **mpls label range minimum-value maximum-value [static minimum-static-value maximum-static-value]**
5. **mpls label protocol ldp**
6. **mpls ip default-route**
7. **mpls ldp graceful-restart**
8. **xconnect logging pseudowire status**
9. **pseudowire-class [pw-class-name]**
10. **encapsulation mpls**
11. **interworking ethernet**
12. **exit**
13. **interface loopback loopback-interface-number**
14. **ip address ip-address mask**
15. **exit**
16. **interface GigabitEthernet slot/subslot/port**
17. **ip address ip-address mask**

18. **negotiation auto**
19. **mpls ip**
20. **exit**
21. **interface atm** *slot/subslot/port*
22. **no ip address**
23. **atm clock internal**
24. **no atm enable-ilmi-trap**
25. **exit**
26. **interface atm** *slot/subslot/port* [*.subinterface-number* {**point-to-point**}]
27. **mtu** *bytes*
28. **no atm enable-ilmi-trap**
29. **pvc** [*name*] *vpi/vci l2transport*
30. **encapsulation** *encapsulation-type*
31. **xconnect** *peer-ip-address vc-id encapsulation mpls pw-class pw-class-name*
32. **exit**

DETAILED STEPS

	Command or Action	Purpose
Step 1	enable Example: Router> enable	Enables the privileged EXEC mode. Enter your password, if prompted.
Step 2	configure terminal Example: Router# configure terminal	Enters the global configuration mode.
Step 3	Router(config)# no ip domain lookup	Disables the IP domain naming system (DNS).
Step 4	mpls label range <i>minimum-value maximum-value</i> [<i>static minimum-static-value maximum-static-value</i>] Example: Router (config)# mpls label range 101 4000 static 4001 5001	Configures the range of local labels available for use with Multiprotocol Label Switching (MPLS) applications on packet interfaces.
Step 5	mpls label protocol ldp Example: Router (config)# mpls label protocol ldp	Specifies label distribution protocol (LDP) for the ATM-PE router.
Step 6	mpls ip default-route Example:	Enables the distribution of labels associated with the IP default route.

	Command or Action	Purpose
	<code>Router(config)# mpls ip default-route</code>	
Step 7	mpls ldp graceful-restart Example: <code>Router(config)# mpls ldp graceful-restart</code>	Enables MPLS LDP graceful restart.
Step 8	xconnect logging pseudowire status Example: <code>Router(config)# xconnect logging pseudowire status</code>	Enables system logging (syslog) reporting of pseudowire status events.
Step 9	pseudowire-class [pw-class-name] Example: <code>Router(config)# pseudowire-class atm-fr-bridged</code>	Establishes a pseudowire class with a name that you specify, and enters the pseudowire class configuration mode.
Step 10	encapsulation mpls Example: <code>Router(config-pw-class)# encapsulation mpls</code>	Enables MPLS encapsulation on the interface.
Step 11	interworking ethernet Example: <code>Router(config-pw-class)# interworking ethernet</code>	Enables the L2VPN Ethernet interworking feature.
Step 12	exit	Exits pseudowire class configuration mode.
Step 13	interface loopback loopback-interface-number Example: <code>Router(config)# interface loopback 0</code>	Specifies the loopback logical interface.
Step 14	ip address ip-address mask Example: <code>Router(config-if)# ip address 44.1.1.2 255.255.255.255</code>	Specifies the IP address for the Loopback interface.
Step 15	exit	Exits interface configuration mode.

	Command or Action	Purpose
Step 16	interface GigabitEthernet <i>slot/subslot/port</i> Example: Router(config)# interface GigabitEthernet 0/0/1	Specifies the Gigabit Ethernet interface for the connection of the PE routers.
Step 17	ip address <i>ip-address mask</i> Example: Router(config-if)# ip address 10.10.1.2 255.255.255.0	Specifies the IP address for the Gigabit Ethernet interface.
Step 18	negotiation auto Example: Router(config-if)# negotiation auto	Enables the auto negotiation protocol to configure the speed, duplex, and automatic flow control of the Gigabit Ethernet interface.
Step 19	mpls ip Example: Router(config-if)# mpls ip	Enables MPLS forwarding of the IPv4 packets towards the MPLS core.
Step 20	exit	Exits interface configuration mode.
Step 21	interface atm <i>slot/subslot/port</i> Example: Router(config)# interface atm 0/1/2	Configures an ATM interface and enters interface configuration mode.
Step 22	no ip address Example: Router(config-if)# no ip address	Removes the previously configured IP address.
Step 23	atm clock internal Example: Router(config-if)# atm clock internal	Enables the ATM interface to generate the transmit clock internally.
Step 24	no atm enable-ilmi-trap Example: Router(config-if)# no atm enable-ilmi-trap	Disables the Integrated Local Management Interface (ILMI) ATM traps.
Step 25	exit	Exits interface configuration mode.

	Command or Action	Purpose
Step 26	interface atm slot/subslot/port [<i>.subinterface-number</i>] {point-to-point} Example: <pre>Router(config)# interface atm 0/1/2.1 point-to-point</pre>	Configures an ATM interface and enters interface configuration mode.
Step 27	mtu bytes Example: <pre>Router(config-subif)# mtu 1500</pre>	Adjusts the maximum packet size or maximum transmission unit (MTU) size. Note The MTU sizes of both the attachment circuits must match.
Step 28	no atm enable-ilmi-trap Example: <pre>Router(config-subif)# no atm enable-ilmi-trap</pre>	Disables the ILMI ATM traps.
Step 29	pvc [<i>name</i>] <i>vpi/vci</i> l2transport Example: <pre>Router(config-subif)# pvc cisco 10/100 l2transport</pre>	Assigns a name to an ATM PVC, specifies the encapsulation type on an ATM PVC, and enters ATM virtual circuit configuration mode.
Step 30	encapsulation encapsulation-type Example: <pre>Router(config-if-atm-l2trans-pvc)# encapsulation aal5snap</pre>	Sets the AAL5SNAP encapsulation (Any-to-Any) for the ATM point-to-point interface.
Step 31	xconnect peer-ip-address vc-id encapsulation mpls pw-class pw-class-name Example: <pre>Router(config-if-atm-l2trans-pvc)# xconnect 190.1.1.1 100 encapsulation mpls pw-class atm-fr-bridged</pre>	Binds an attachment circuit to a pseudowire and configures an Any Transport over MPLS (AToM) static pseudowire.
Step 32	exit	Exits global configuration mode.

Example: Frame Relay-to-ATM Bridged Interworking on an ATM-PE Router

The following example shows the configuration of the Frame Relay-to-ATM Bridged Interworking feature on an ATM-PE router:

```
no ip domain lookup
mpls label range 101 4000 static 4001 5001
```

```

mpls label protocol ldp
mpls ip default-route
mpls ldp graceful-restart
xconnect logging pseudowire status
!
pseudowire-class atm-fr-bridged
encapsulation mpls
interworking ethernet
!
interface Loopback0
ip address 44.1.1.2 255.255.255.255
!
interface GigabitEthernet0/0/1
ip address 10.10.1.2 255.255.255.0
negotiation auto
mpls ip
!
interface ATM0/1/2
no ip address
atm clock INTERNAL
no atm enable-ilmi-trap
!
interface ATM0/1/2.1 point-to-point
mtu 1500
no atm enable-ilmi-trap
pvc 10/100 12transport
encapsulation aal5snap
xconnect 190.1.1.1 100 pw-class atm-fr-bridged
!
!

```

Example: Frame Relay-to-ATM Bridged Interworking on a Frame Relay-PE Router

The following example shows the configuration of the Frame Relay-to-ATM Bridged Interworking feature on a Frame Relay-PE router:

```

ipv6 unicast-routing
mpls label protocol ldp
mpls ip default-route
mpls ldp graceful-restart
frame-relay switching
xconnect logging pseudowire status
!
controller T1 0/3/0
framing esf
clock source internal
linecode b8zs
cablelength long 0db
channel-group 0 timeslots 1-24
!
pseudowire-class atm-fr-bridged
encapsulation mpls
interworking ethernet
!
interface Loopback0
ip address 190.1.1.1 255.255.255.255
!
interface Serial0/3/0:0
no ip address
encapsulation frame-relay

```

```

frame-relay intf-type dce
frame-relay interface-dlci 101 switched
!
interface GigabitEthernet1/3/1
ip address 10.10.1.1 255.255.255.0
negotiation auto
mpls ip
!
connect fr-atm-2 Serial0/3/0:0 101 l2transport
xconnect 44.1.1.2 100 pw-class atm-fr-bridged
!

```

Gigabit EtherChannel for Virtual Private Wire Service

GEC for AToM is a solution for a VPWS transporting Layer 2 packets over an MPLS backbone with GEC.

This feature enables service providers to supply connectivity between customer sites having data link layer (Layer 2) networks, by using a single, integrated, packet-based network infrastructure—a Cisco MPLS network. Instead of separate networks with separate network management environments, service providers can deliver Layer 2 connections over an MPLS backbone.

Supported Modes

The following modes are supported in the GEC for VPWS feature:

GEC Like-to-Like Mode

The GEC Like-to-Like mode allows switching of data between two physical interfaces in which the two segments (CE1-PE1 and CE2-PE2, as shown in the following figure are both of GEC type.

The GEC Like-to-Like mode has the following features:

Figure 5: Topology of the GEC Like-to-Like Mode for the GEC for VPWS Feature

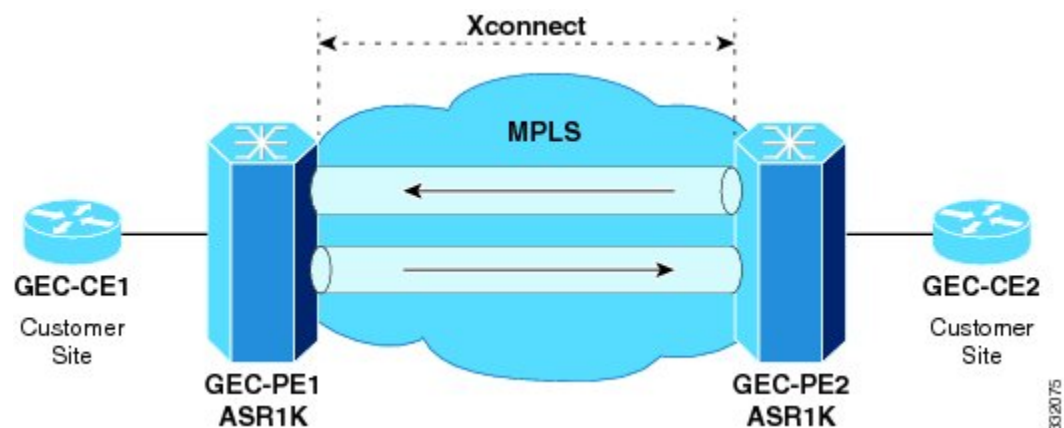

Any-to-GEC Mode

The Any-to-GEC mode allows switching of data between two physical interfaces in which the two segments, CE1-PE1 and CE2-PE2, are both of different types, while one is GEC, the other can be PPP, Ethernet, Frame Relay, or ATM, as shown in the following figure.

The Any-to-GEC mode has the following features:

Figure 6: Topology of the Any-to-GEC Mode for the GEC for VPWS Feature

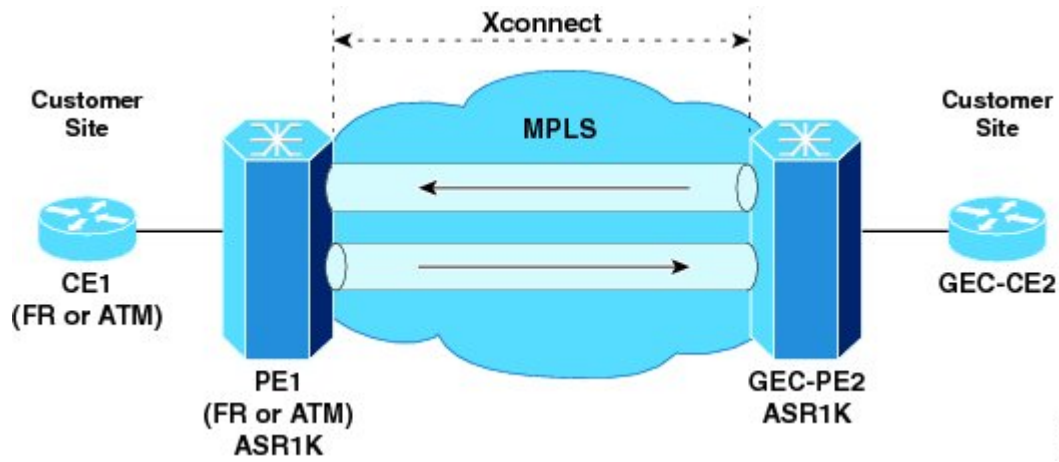

Note Bridged interworking is used when Layer 2 (L2) packets are considered without regard for Layer 3 contents. In bridged interworking, Ethernet frames that are extracted from the attachment circuit are sent over the MPLS pseudowire.



Note Routed interworking is used to carry Layer 3 packets. In routed interworking, IP packets that are extracted from the attachment circuits are sent over the MPLS pseudowire.

Restrictions for Gigabit EtherChannel for Virtual Private Wire Service

The following are the restrictions for Gigabit EtherChannel for VPWS are the followings:

- GEC for VPWS does not support Q-in-Q encapsulation and remote port shutdown.
- A maximum four member links are supported under the port channel and a maximum of 64 port channel bundles are supported per router.

Configuring Gigabit EtherChannel for Virtual Private Wire Service

The GEC VPWS support feature is supported by AToM on the EtherChannel Interface, and includes the following features:

EtherChannel-to-EtherChannel over MPLS (Bridged) Interworking

Configure L2VPN interworking on the upstream interfaces of the PE routers.

After configuring MPLS Forwarding, perform the following steps on the downstream interfaces of the PE routers:

SUMMARY STEPS

1. enable
2. **configure terminal**
3. mpls label protocol ldp
4. interface loopback loopback-interface-number
5. ip address ip-address mask
6. exit
7. pseudowire-class pw-class-name
8. encapsulation mpls
9. interworking ethernet
10. exit
11. interface port-channel number
12. xconnect peer-ip-address vc-id encapsulation mpls pseudowire-class pw-class-name
13. interface GigabitEthernet slot | subslot | port
14. channel-group port-channel number

DETAILED STEPS

	Command or Action	Purpose
Step 1	enable	Changes the privilege level for the corresponding CLI session.
Step 2	configure terminal Example: Router# configure terminal	Enters global configuration mode.
Step 3	mpls label protocol ldp Example: Router# mpls label protocol ldp	Specifies that LDP is the default label distribution protocol.
Step 4	interface loopback loopback-interface-number Example: Router# interface loopback 1	Specifies the loopback interface, and enters interface configuration mode.
Step 5	ip address ip-address mask Example: Router# ip address 10.10.2.1 255.255.255.0	Sets the IP address and mask for the loopback interface.
Step 6	exit	Exits interface configuration mode.

	Command or Action	Purpose
Step 7	pseudowire-class pw-class-name Example: Router(config)# pseudowire-class gec-bridged	Specifies the name of a Layer 2 pseudowire class and enters the pseudowire class configuration mode.
Step 8	encapsulation mpls Example: Router(config-pw)# encapsulation mpls	Uses MPLS as the tunneling method to encapsulate data in the pseudowire.
Step 9	interworking ethernet Example: Router(config-pw)# interworking ethernet	Enables the L2VPN Interworking feature, and causes Ethernet frames to be extracted from the attachment circuit and sent over the pseudowire. Ethernet end-to-end transmission is assumed. Attachment circuit frames that do not contain Ethernet frames are dropped. In the case of VLAN, the VLAN tag is removed, which leaves a pure Ethernet frame.
Step 10	exit	Exits xconnect configuration mode.
Step 11	interface port-channel number Example: Router(config)# interface port-channel 1	Creates an EtherChannel interface on the Cisco Cable Modem Termination System (CMTS).
Step 12	xconnect peer-ip-address vc-id encapsulation mpls pseudowire-class pw-class-name Example: Router(config-if)# xconnect 10.0.0.1 707 encapsulation mpls pseudowire-class gec-bridged	Binds an attachment circuit to a pseudowire to configure an AToM static pseudowire, specifies MPLS as the tunneling method, and enters the xconnect configuration mode.
Step 13	interface GigabitEthernet slot subslot port Example: Router(config)# interface GigabitEthernet 0/0/1	Specifies the Gigabit Ethernet interface, and enters interface configuration mode.
Step 14	channel-group port-channel number Example: Router(config-if) channel-group 1	Configures an EtherChannel interface to an EtherChannel group.

What to do next

Note The EtherChannel-to-EtherChannel over MPLS (Bridged) Interworking mode is also supported under VLAN.

EtherChannel-to-EtherChannel over MPLS (Routed) Interworking

Configure L2VPN interworking on the upstream interfaces of the PE routers.

After configuring MPLS Forwarding, perform the following steps on the downstream interfaces of the PE routers:

SUMMARY STEPS

1. enable
2. **configure terminal**
3. mpls label protocol ldp
4. interface loopback loopback-interface-number
5. ip address ip-address mask
6. exit
7. pseudowire-class pw-class-name
8. encapsulation mpls
9. interworking ip
10. exit
11. interface port-channel number
12. xconnect peer-ip-address vc-id encapsulation mpls pseudowire-class pw-class-name
13. interface GigabitEthernet slot | subslot | port
14. channel-group port-channel number

DETAILED STEPS

	Command or Action	Purpose
Step 1	enable	Changes the privilege level for the corresponding CLI session.
Step 2	configure terminal Example: Router# configure terminal	Enters global configuration mode.
Step 3	mpls label protocol ldp Example: Router# mpls label protocol ldp	Specifies that LDP is the default label distribution protocol.
Step 4	interface loopback loopback-interface-number Example: Router# interface loopback 1	Specifies the loopback interface, and enters interface configuration mode.
Step 5	ip address ip-address mask Example:	Sets the IP address and mask for the loopback interface.

	Command or Action	Purpose
	Router# ip address 10.10.2.1 255.255.255.0	
Step 6	exit	Exits interface configuration mode.
Step 7	pseudowire-class pw-class-name Example: Router(config)# pseudowire-class gec-bridged	Specifies the name of a Layer 2 pseudowire class and enters pseudowire class configuration mode.
Step 8	encapsulation mpls Example: Router(config-pw)# encapsulation mpls	Uses MPLS as the tunneling method to encapsulate data in the pseudowire.
Step 9	interworking ip Example: Router(config-pw)# interworking ip	Enables the L2VPN Interworking feature, and causes IP packets to be extracted from the attachment circuit and sent over the pseudowire. Attachment circuit frames that do not contain IPv4 packets are dropped.
Step 10	exit	Exits xconnect configuration mode.
Step 11	interface port-channel number Example: Router(config)# interface port-channel 1	Creates an EtherChannel interface on the Cisco Cable Modem Termination System (CMTS).
Step 12	xconnect peer-ip-address vc-id encapsulation mpls pseudowire-class pw-class-name Example: Router(config-if)# xconnect 10.0.0.1 707 encapsulation mpls pseudowire-class gec-routed	Binds an attachment circuit to a pseudowire to configure an AToM static pseudowire, specifies MPLS as the tunneling method, and enters xconnect configuration mode.
Step 13	interface GigabitEthernet slot subslot port Example: Router(config)# interface GigabitEthernet 0/0/1	Specifies the Gigabit Ethernet interface, and enters interface configuration mode.
Step 14	channel-group port-channel number Example: Router(config-if) channel-group 1	Configures EtherChannel interfaces to an EtherChannel group.

What to do next

Note The EtherChannel-to-EtherChannel over MPLS (Routed) Interworking mode is also supported under VLAN.

Example: GEC Like-to-Like (Routed) Interworking

The following example shows the configuration of the GEC Like-to-Like (Routed) Interworking feature:

```
no ip domain lookup
mpls label range 101 4000 static 4001 5001
mpls label protocol ldp
mpls ip default-route
mpls ldp graceful-restart
xconnect logging pseudowire status
!
pseudowire-class gec-bridged
encapsulation mpls
interworking ethernet!
pseudowire-class gec-routed
encapsulation mpls
interworking ip
!
interface Loopback0
ip address 44.1.1.2 255.255.255.255
!
interface GigabitEthernet0/0/1
ip address 10.10.1.2 255.255.255.0
negotiation auto
mpls ip
!
interface port-channel 1
xconnect 190.1.1.1 100 encapsulation mpls pw-class gec-bridged
!
interface GigabitEthernet0/0/3
channel-group 1
!
interface GigabitEthernet0/0/2
channel-group 1
!
router ospf 10
log-adjacency-changes
network 44.1.1.2 0.0.0.0 area 0
network 10.10.1.2 0.0.0.255 area 0
```

Any-to-EtherChannel over MPLS (Bridged) Interworking

You can configure Any-to-EtherChannel over MPLS (Bridged) interworking on the Cisco ASR 1000 Series Routers.

Any-to-EtherChannel over MPLS (Bridged) interworking supports the following modes:

- Frame Relay-to-EtherChannel
- ATM-to-EtherChannel
- Ethernet-to-EtherChannel

Irrespective of the mode used, in Any-to-EtherChannel over MPLS (Bridged) interworking, configure L2VPN interworking on the upstream interfaces of PE routers.

Perform the following steps on the downstream interfaces of the PE routers:

SUMMARY STEPS

1. enable
2. **configure terminal**
3. mpls label protocol ldp
4. interface loopback loopback-interface-number
5. ip address ip-address mask
6. exit
7. pseudowire-class pw-class-name
8. encapsulation mpls
9. interworking ethernet
10. interface GigabitEthernet slot | subslot | port
11. xconnect peer-ip-address vc-id encapsulation mpls pseudowire-class pw-class-name

DETAILED STEPS

	Command or Action	Purpose
Step 1	enable	Changes the privilege level for the corresponding CLI session.
Step 2	configure terminal Example: Router# configure terminal	Enters global configuration mode.
Step 3	mpls label protocol ldp Example: Router# mpls label protocol ldp	Specifies that LDP is the default label distribution protocol.
Step 4	interface loopback loopback-interface-number Example: Router# interface loopback 1	Specifies the loopback interface, and enters the interface configuration mode.
Step 5	ip address ip-address mask Example: Router# ip address 10.10.2.1 255.255.255.0	Sets the IP address and mask for the loopback interface.
Step 6	exit	Exits interface configuration mode.
Step 7	pseudowire-class pw-class-name Example:	Specifies the name of a Layer 2 pseudowire class and enters the pseudowire class configuration mode.

	Command or Action	Purpose
	<code>Router(config)# pseudowire-class gec-bridged</code>	
Step 8	<p>encapsulation mpls</p> <p>Example:</p> <pre>Router(config-pw)# encapsulation mpls</pre>	Uses MPLS as the tunneling method to encapsulate data in the pseudowire.
Step 9	<p>interworking ethernet</p> <p>Example:</p> <pre>Router(config-pw)# interworking ethernet</pre>	Enables the L2VPN Interworking feature, and causes Ethernet frames to be extracted from the attachment circuit and sent over the pseudowire. Ethernet end-to-end transmission is assumed. Attachment circuit frames that do not contain Ethernet frames are dropped. In the case of VLAN, the VLAN tag is removed, which leaves a pure Ethernet frame.
Step 10	<p>interface GigabitEthernet slot subslot port</p> <p>Example:</p> <pre>Router(config)# interface GigabitEthernet 0/0/1</pre>	Specifies the Gigabit Ethernet interface, and enters interface configuration mode.
Step 11	<p>xconnect peer-ip-address vc-id encapsulation mpls pseudowire-class pw-class-name</p> <p>Example:</p> <pre>Router(config-if)# xconnect 10.0.0.1 707 encapsulation mpls pseudowire-class gec-bridged</pre>	Binds an attachment circuit to a pseudowire to configure an AToM static pseudowire, specifies MPLS as the tunneling method, and enters the xconnect configuration mode.

What to do next



Note Ethernet-to-EtherChannel over MPLS (Bridge) Interworking mode is also supported under VLAN.

Any-to-EtherChannel over MPLS (Routed) Interworking

You can configure Any-to-EtherChannel over MPLS (Routed) interworking on the Cisco ASR 1000 Series Routers.

Any-to-EtherChannel over MPLS (Routed) interworking supports the following modes:

- ATM-to-EtherChannel
- Ethernet-to-EtherChannel
- PPP-to-EtherChannel

Configure L2VPN interworking on the upstream interfaces of PE routers.

Perform the following steps on the downstream interfaces of the PE routers:

SUMMARY STEPS

1. **enable**
2. configure terminal
3. ipv6 unicast-routing
4. **mpls ip default-route**
5. **mpls ldp graceful-restart**
6. **xconnect logging pseudowire status**
7. controller t1 slot/subslot/port
8. clock source internal
9. linecode b8zs
10. cablelength long db-loss-value
11. channel-group *channel-group-number* timeslots *range*
12. exit
13. pseudowire-class [*pw-class-name*]
14. encapsulation mpls
15. interworking ethernet
16. exit
17. *interface loopback loopback-interface-number*
18. **ip address** *ip-address mask*
19. **exit**
20. **interface serial** slot/subslot/port:timeslot
21. no ip address
22. **encapsulation ppp**
23. clock source internal
24. xconnect peer-loopback vc-id pw-class pe-class-name

DETAILED STEPS

	Command or Action	Purpose
Step 1	enable Example: Router> enable	Enables privileged EXEC mode. Enter your password, if prompted.
Step 2	configure terminal Example: Router# configure terminal	Enters global configuration mode.
Step 3	ipv6 unicast-routing Example: Router# ipv6 unicast-routing	(Optional) Enables the task of forwarding the IPv6 unicast datagrams.
Step 4	mpls ip default-route Example:	Enables the distribution of labels associated with the IP default route.

	Command or Action	Purpose
	<code>Router(config)# mpls ip default-route</code>	
Step 5	mpls ldp graceful-restart Example: <code>Router(config)# mpls ldp graceful-restart</code>	Enables MPLS LDP graceful restart.
Step 6	xconnect logging pseudowire status Example: <code>Router(config)# xconnect logging pseudowire status</code>	Enables system logging (syslog) reporting of pseudowire status events.
Step 7	<code>controller t1 slot/subslot/port</code> Example: <code>Router(config)# controller T1 0/3/0</code>	Configures a T1 controller and enters controller configuration mode.
Step 8	<code>clock source internal</code> Example: <code>Router(config-controller)# clock source internal</code>	Configures the clock source of a DS1 link and uses the internal clock from the interface.
Step 9	<code>linecode b8zs</code> Example: <code>Router(config-controller)# linecode b8zs</code>	Specifies Binary 8-Zero Substitution (B8ZS) as the line code type for the T1 controller.
Step 10	<code>cablelength long db-loss-value</code> Example: <code>Router(config-controller)# cablelength long 0db</code>	Decreases the transmit signal by 0 dB. This is the default value.
Step 11	<code>channel-group channel-group-number timeslots range</code> Example: <code>Router(config-controller)# channel-group 0 timeslots 1-24</code>	Configures serial WAN on a T1 or E1 interface.
Step 12	<code>exit</code>	Exits pseudowire class configuration mode.
Step 13	<code>pseudowire-class [pw-class-name]</code> Example: <code>Router(config)# pseudowire-class atm-fr-bridged</code>	Establishes a pseudowire class with a name that you specify and enters the pseudowire class configuration mode.

	Command or Action	Purpose
Step 14	encapsulation mpls Example: Router(config-pw-class)# encapsulation mpls	Enables MPLS encapsulation on the interface.
Step 15	interworking ethernet Example: Router(config-pw-class)# interworking ethernet	Enables the L2VPN Ethernet interworking feature.
Step 16	exit	Exits pseudowire class configuration mode.
Step 17	<i>interface loopback loopback-interface-number</i> Example: Router(config)# interface loopback 0	Specifies the Loopback logical interface.
Step 18	ip address ip-address mask Example: Router(config-if)# ip address 44.1.1.2 255.255.255.255	Specifies the IP address for the Loopback interface.
Step 19	exit	Exits the interface configuration mode.
Step 20	interface serial slot/subslot/port:timeslot Example: Router(config)# interface Serial0/3/0:0	Specifies a serial interface created on a channelized T1 controller.
Step 21	no ip address Example: Router(config-if)# no ip address	Removes the previously configured IP address.
Step 22	encapsulation ppp Example: Router(config-if)# encapsulation frame-relay	Configures the PPP (for serial interface) encapsulation on serial interface.
Step 23	clock source internal	Specifies that the T1/E1 link uses the internal clock from the interface.
Step 24	xconnect peer-loopback vc-id pw-class pe-class-name	Binds an attachment circuit to a pseudowire to configure an AToM static pseudowire, specifies MPLS as the tunneling method, and enters xconnect configuration mode.

What to do next

Note Ethernet-to-EtherChannel over MPLS (Bridge) Interworking mode is also supported under VLAN.

High-Level Data Link Control-Ethernet Interworking

HDLC-Ethernet over MPLS is part of Any Transport over MPLS (AToM) solution. High-Level Link Control (HDLC) and Ethernet are two link-layer transports that utilize the AToM architecture. This section describes how these two transport types can communicate with each other using the AToM framework.

The following figure shows the topology of the HDLC-Ethernet Interworking feature.

Figure 7: Topology of the HDLC-Ethernet Interworking Feature

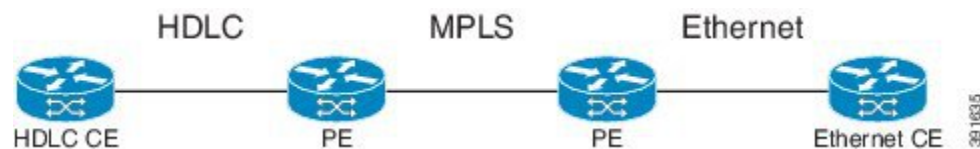

The following features are supported from Cisco IOS XE Release 3.13.0S on the Cisco ASR 1000 Series Aggregation Services Routers:

- HDLC-Ethernet Bridged-Mode Interworking
- HDLC-Ethernet Routed-Mode Interworking
- HDLC Encapsulation: CISCO
- Ethernet Encapsulation: Dot1Q, QinQ, Port Interface

Prerequisites for HDLC-Ethernet Interworking

Perform the following tasks to enable HDLC-Ethernet interworking:

- Configure a controller slot on Ethernet CE:

```
controller E1 2/0
channel-group 0 timeslots 1
no shutdown
interface Serial12/0:0
no shutdown
```

- Configure an Ethernet CE interface for Ethernet interworking:

```
bridge irb
bridge 1 protocol ieee
bridge 1 route ip
interface Serial12/0:0
no bridge-group 1
no ip address
!
int BV11
no ip address
ip address 192.168.1.1 255.255.255.0
no shut
```

```

!
interface Serial2/0:0
description Connect to PE1
no ip address
encapsulation hdlc
bridge-group 1
no shut

```

- Configure an Ethernet CE interface for IP interworking:

```

interface Serial2/0:0
description Connect to PE1
ip address 192.168.1.1 255.255.255.0
encapsulation hdlc
no shut

```

Restrictions for HDLC-Ethernet Interworking

The following features are not supported:

- HDLC encapsulation: none CISCO
- IPv6 is not supported in routed mode

Configuring HDLC-Ethernet Interworking

HDLC-Ethernet Interworking can be configured in the following two modes:

Bridge Mode

Perform the following steps to configure the HDLC-Ethernet Interworking in the bridge mode via interface-based configuration:

On the HDLC-PE

SUMMARY STEPS

1. enable
2. **configure terminal**
3. pseudowire-class pw-class-name
4. encapsulation mpls
5. interworking ethernet
6. interface serial slot | subslot | port
7. **no ip address**
8. xconnect peer-ip-address vc-id pseudowire-class pw-class-name

DETAILED STEPS

	Command or Action	Purpose
Step 1	enable	Changes the privilege level for the corresponding CLI session.

	Command or Action	Purpose
Step 2	configure terminal Example: Router# configure terminal	Enters global configuration mode.
Step 3	pseudowire-class pw-class-name Example: Router(config)# pseudowire-class pw-iw-ether	Specifies the name of a Layer 2 pseudowire class and enters pseudowire class configuration mode.
Step 4	encapsulation mpls Example: Router(config-pw)# encapsulation mpls	Uses MPLS as the tunneling method to encapsulate data in the pseudowire.
Step 5	interworking ethernet Example: Router(config-pw)# interworking ethernet	Enables the L2VPN Interworking feature, and causes Ethernet frames to be extracted from the attachment circuit and sent over the pseudowire. Ethernet end-to-end transmission is assumed. Attachment circuit frames that do not contain Ethernet frames are dropped. In the case of VLAN, the VLAN tag is removed, which leaves a pure Ethernet frame.
Step 6	interface serial slot subslot port Example: Router(config)# interface Serial0/1/0:0	Specifies the serial interface, and enters interface configuration mode.
Step 7	no ip address Example: Router(config-if)# no ip address	Removes all the IP addresses of the interface.
Step 8	xconnect peer-ip-address vc-id pseudowire-class pw-class-name Example: Router(config-if)# xconnect 17.17.17.17 100 pw-class pw-iw-ether	Binds an attachment circuit to a pseudowire to configure an AToM static pseudowire, specifies MPLS as the tunneling method, and enters xconnect configuration mode.

On the Ethernet PE

SUMMARY STEPS

1. enable
2. **configure terminal**
3. pseudowire-class pw-class-name

4. `encapsulation mpls`
5. `interworking ethernet`
6. `interface GigabitEthernet slot | subslot | port`
7. `encapsulation dot1Q vlan-id`
8. `xconnect peer-ip-address vc-id pseudowire-class pw-class-name`

DETAILED STEPS

	Command or Action	Purpose
Step 1	<code>enable</code>	Changes the privilege level for the corresponding CLI session.
Step 2	configure terminal Example: <code>Router# configure terminal</code>	Enters global configuration mode.
Step 3	<code>pseudowire-class pw-class-name</code> Example: <code>Router(config)# pseudowire-class pw-iw-ether</code>	Specifies the name of a Layer 2 pseudowire class and enters pseudowire class configuration mode.
Step 4	<code>encapsulation mpls</code> Example: <code>Router(config-pw)# encapsulation mpls</code>	Uses MPLS as the tunneling method to encapsulate data in the pseudowire.
Step 5	<code>interworking ethernet</code> Example: <code>Router(config-pw)# interworking ethernet</code>	Enables the L2VPN Interworking feature, and causes Ethernet frames to be extracted from the attachment circuit and sent over the pseudowire. Ethernet end-to-end transmission is assumed. Attachment circuit frames that do not contain Ethernet frames are dropped. In the case of VLAN, the VLAN tag is removed, which leaves a pure Ethernet frame.
Step 6	<code>interface GigabitEthernet slot subslot port</code> Example: <code>Router(config)# interface GigabitEthernet0/0/0.3</code>	Specifies the Gigabit Ethernet interface, and enters interface configuration mode.
Step 7	<code>encapsulation dot1Q vlan-id</code> Example: <code>Router(config-if)# encapsulation dot1Q 3</code>	Removes all the IP addresses of the interface.

	Command or Action	Purpose
Step 8	<pre>xconnect peer-ip-address vc-id pseudowire-class pw-class-name</pre> <p>Example:</p> <pre>Router(config-if)# xconnect 16.16.16.16 100 pseudowire-class pw-iw-ether</pre>	Binds an attachment circuit to a pseudowire to configure an AToM static pseudowire, specifies MPLS as the tunneling method, and enters xconnect configuration mode.

What to do next

Perform the following steps to configure the HDLC-Ethernet Interworking in the bridge mode via protocol-based configuration:

On the HDLC-PE

SUMMARY STEPS

1. enable
2. **configure terminal**
3. **l2vpn xconnect context xc-name**
4. **interworking ethernet**
5. **member interface-id**
6. **member ip-address vc-id encapsulation mpls**

DETAILED STEPS

	Command or Action	Purpose
Step 1	enable	Changes the privilege level for the corresponding CLI session.
Step 2	<p>configure terminal</p> <p>Example:</p> <pre>Router# configure terminal</pre>	Enters global configuration mode.
Step 3	<p>l2vpn xconnect context xc-name</p> <p>Example:</p> <pre>Router(config)# l2vpn xconnect context HDLC</pre>	Creates an empty cross-connect, and enters xconnect submode.
Step 4	<p>interworking ethernet</p> <p>Example:</p> <pre>Router(config)# interworking ethernet</pre>	Enables the L2VPN Interworking feature, and causes Ethernet frames to be extracted from the attachment circuit and sent over the pseudowire. Ethernet end-to-end transmission is assumed. Attachment circuit frames that do not contain Ethernet frames are dropped. In the case of VLAN, the VLAN tag is removed, which leaves a pure Ethernet frame.

	Command or Action	Purpose
Step 5	member interface-id Example: Router(config)# member serial0/1/0:0	Adds an interface as an AC segment of xconnect.
Step 6	member ip-address vc-id encapsulation mpls Example: Router(config)# member 17.17.17.17 100 encapsulation mpls	Adds a pseudowire member to xconnect.

On the Ethernet PE

SUMMARY STEPS

1. enable
2. **configure terminal**
3. **l2vpn xconnect context foo**
4. **interworking ethernet**
5. **member interface-id**
6. **member ip-address vc-id encapsulation mpls**

DETAILED STEPS

	Command or Action	Purpose
Step 1	enable	Changes the privilege level for the corresponding CLI session.
Step 2	configure terminal Example: Router# configure terminal	Enters global configuration mode.
Step 3	l2vpn xconnect context foo Example: Router(config)# l2vpn xconnect context foo	Creates an empty cross-connect, and enters xconnect submode.
Step 4	interworking ethernet Example: Router(config)# interworking ethernet	Enables the L2VPN Interworking feature, and causes Ethernet frames to be extracted from the attachment circuit and sent over the pseudowire. Ethernet end-to-end transmission is assumed. Attachment circuit frames that do not contain Ethernet frames are dropped. In the case of VLAN, the VLAN tag is removed, which leaves a pure Ethernet frame.

	Command or Action	Purpose
Step 5	member interface-id Example: <pre>Router(config)# member GigabitEthernet0/0/0.3</pre>	Adds an interface as an AC segment of xconnect.
Step 6	member ip-address vc-id encapsulation mpls Example: <pre>Router(config)# member 16.16.16.16 100 encapsulation mpls</pre>	Adds a pseudowire member to xconnect.

Routed Mode

Perform the following steps to configure the HDLC-Ethernet Interworking in the routed mode via interface-based configuration:

On HDLC-PE

SUMMARY STEPS

1. enable
2. **configure terminal**
3. pseudowire-class pw-class-name
4. encapsulation mpls
5. interworking ip
6. interface serial slot | subslot | port
7. **no ip address**
8. xconnect peer-ip-address vc-id pseudowire-class pw-class-name

DETAILED STEPS

	Command or Action	Purpose
Step 1	enable	Changes the privilege level for the corresponding CLI session.
Step 2	configure terminal Example: <pre>Router# configure terminal</pre>	Enters global configuration mode.
Step 3	pseudowire-class pw-class-name Example: <pre>Router(config)# pseudowire-class pw-ip-ether</pre>	Specifies the name of a Layer 2 pseudowire class and enters pseudowire class configuration mode.

	Command or Action	Purpose
Step 4	encapsulation mpls Example: Router(config-pw)# encapsulation mpls	Uses MPLS as the tunneling method to encapsulate data in the pseudowire.
Step 5	interworking ip Example: Router(config-pw)# interworking ip	Enables the L2VPN Interworking feature, and causes IP packets to be extracted from the attachment circuit and sent over the pseudowire. Attachment circuit frames that do not contain IPv4 packets are dropped.
Step 6	interface serial slot subslot port Example: Router(config)# interface Serial10/1/0:0	Specifies the serial interface, and enters interface configuration mode.
Step 7	no ip address Example: Router(config-if)# no ip address	Removes all the IP addresses of the interface.
Step 8	xconnect peer-ip-address vc-id pseudowire-class pw-class-name Example: Router(config-if)# xconnect 17.17.17.17 100 pw-class pw-ip-ether	Binds an attachment circuit to a pseudowire to configure an AToM static pseudowire, specifies MPLS as the tunneling method, and enters xconnect configuration mode.

On Ethernet PE

SUMMARY STEPS

1. enable
2. **configure terminal**
3. pseudowire-class pw-class-name
4. encapsulation mpls
5. interworking ip
6. interface GigabitEthernet slot | subslot | port
7. **encapsulation dot1Q** vlan-id
8. xconnect peer-ip-address vc-id pseudowire-class pw-class-name

DETAILED STEPS

	Command or Action	Purpose
Step 1	enable	Changes the privilege level for the corresponding CLI session.

	Command or Action	Purpose
Step 2	configure terminal Example: Router# configure terminal	Enters global configuration mode.
Step 3	pseudowire-class pw-class-name Example: Router(config)# pseudowire-class pw-ip-ether	Specifies the name of a Layer 2 pseudowire class and enters pseudowire class configuration mode.
Step 4	encapsulation mpls Example: Router(config-pw)# encapsulation mpls	Uses MPLS as the tunneling method to encapsulate data in the pseudowire.
Step 5	interworking ip Example: Router(config-pw)# interworking ip	Enables the L2VPN Interworking feature, and causes IP packets to be extracted from the attachment circuit and sent over the pseudowire. Attachment circuit frames that do not contain IPv4 packets are dropped.
Step 6	interface GigabitEthernet slot subslot port Example: Router(config)# interface GigabitEthernet0/0/0.3	Specifies the Gigabit Ethernet interface, and enters interface configuration mode.
Step 7	encapsulation dot1Q vlan-id Example: Router(config-if)# encapsulation dot1Q 3	Enables IEEE 802.1Q encapsulation of traffic on a specified subinterface in a VLAN.
Step 8	xconnect peer-ip-address vc-id pseudowire-class pw-class-name Example: Router(config-if)# xconnect 16.16.16.16 100 pseudowire-class pw-ip-ether	Binds an attachment circuit to a pseudowire to configure an AToM static pseudowire, specifies MPLS as the tunneling method, and enters xconnect configuration mode.

What to do next

Perform the following steps to configure the HDLC-Ethernet Interworking in the routed mode via protocol-based configuration:

On HDLC-PE

SUMMARY STEPS

1. enable
2. **configure terminal**
3. **l2vpn xconnect context foo**
4. **interworking ip**
5. **member interface-id**
6. **member ip-address encapsulation mpls**

DETAILED STEPS

	Command or Action	Purpose
Step 1	enable	Changes the privilege level for the corresponding CLI session.
Step 2	configure terminal Example: Router# configure terminal	Enters global configuration mode.
Step 3	l2vpn xconnect context foo Example: Router(config)# l2vpn xconnect context foo	Creates an empty cross-connect, and enters xconnect submode.
Step 4	interworking ip Example: Router(config)# interworking ip	Enables the L2VPN Interworking feature, and causes IP packets to be extracted from the attachment circuit and sent over the pseudowire. Attachment circuit frames that do not contain IPv4 packets are dropped.
Step 5	member interface-id Example: Router(config)# member serial10/1/0:0	Adds an interface as an AC segment of xconnect.
Step 6	member ip-address encapsulation mpls Example: Router(config)# member 17.17.17.17 100 encapsulation mpls	Adds a pseudowire member to xconnect.

On Ethernet PE

SUMMARY STEPS

1. enable

2. **configure terminal**
3. **l2vpn xconnect context foo**
4. **interworking ip**
5. **member interface-id**
6. **member ip-address vcid encapsulation mpls**

DETAILED STEPS

	Command or Action	Purpose
Step 1	enable	Changes the privilege level for the corresponding CLI session.
Step 2	configure terminal Example: Router# configure terminal	Enters global configuration mode.
Step 3	l2vpn xconnect context foo Example: Router(config)# l2vpn xconnect context foo	Creates an empty cross-connect, and enters xconnect submode.
Step 4	interworking ip Example: Router(config)# interworking ip	Enables the L2VPN Interworking feature, and causes IP packets to be extracted from the attachment circuit and sent over the pseudowire. Attachment circuit frames that do not contain IPv4 packets are dropped.
Step 5	member interface-id Example: Router(config)# member GigabitEthernet0/0/0.3	Adds an interface as an AC segment of xconnect.
Step 6	member ip-address vcid encapsulation mpls Example: Router(config)# member 16.16.16.16 100 encapsulation mpls	Adds a pseudowire member to xconnect.

Example: HDLC-Ethernet Interworking Configuration

The following examples show how to configure the HDLC-Ethernet Interworking feature, and verify the configuration using **show** commands for legacy and new protocol-based outputs on the Cisco ASR 1000 Series Aggregation Services Routers:

Example: Different Forms of Protocol-Based CLI Configuration

The following example shows how to configure the HDLC-Ethernet interworking on the Controller slot on Ethernet CE:

```

controller E1 2/0
channel-group 0 timeslots 1
no shutdown
interface Serial2/0:0
no shutdown

```

The following example shows how to configure the HDLC-Ethernet interworking on the Controller slot on Ethernet PE:

```

controller E1 0/1/0
channel-group 0 timeslots 1
no shutdown
interface Serial0/1/0:0
no shutdown

```

The following example shows how to configure the HDLC-Ethernet interworking using legacy CLI.

The following example shows how to configure on HDLC-CE and HDLC-PE in Bridged (Ethernet) mode using legacy CLI:

On HDLC-CE

```

configure terminal
bridge irb
bridge 1 protocol ieee
bridge 1 route ip
!
int BVI1
ip address 192.168.1.1 255.255.255.0
no shut
!
interface Serial2/0:0
description Connect to PE1
encapsulation hdlc
bridge-group 1
no shut
end

```

HDLC-PE:

```

configure terminal
pseudowire-class pw-iv-eth
 encapsulation mpls
 interworking Ethernet
!
interface Serial0/1/0:0
 description Connect to CE1
 encapsulation hdlc
 no ip address
 xconnect 192.0.2.3 100 pw-class pw-iv-eth
 no shut
end

```

The following example shows how to configure Ethernet on Ethernet-CE and Ethernet-PE in Bridged (Ethernet) mode using legacy CLI:

On Ethernet-CE

```

configure terminal
interface GigabitEthernet0/1
description Connect to PE2

```

```

ip address 192.168.1.2 255.255.255.0
ip irdp
ip irdp maxadvertinterval 4
no shut
end

```

On Ethernet-PE

```

configure terminal
pseudowire-class pw-iw-eth
  encapsulation mpls
  interworking Ethernet
!
interface GigabitEthernet1/0/0
  description Connect to CE2
  no ip address
xconnect 192.0.2.1 100 pw-class pw-iw-eth
  no shut
end

```

The following example shows how to configure VLAN at Ethernet-CE and Ethernet-PE in Bridged (Ethernet) mode using legacy CLI:

On Ethernet-CE:

```

configure terminal
interface GigabitEthernet0/1
no ip address
no shut
!
interface GigabitEthernet0/1.10
description Connect to PE2
encapsulation dot1q 10
ip address 192.168.1.2 255.255.255.0
ip irdp
ip irdp maxadvertinterval 4
no shut
end

```

On Ethernet-PE:

```

configure terminal
pseudowire-class pw-iw-eth
  encapsulation mpls
  interworking Ethernet
!
interface GigabitEthernet1/0/0
no ip address
no shut
!
interface GigabitEthernet1/0/0.10
  description Connect to CE2
  encapsulation dot1Q 10
  no ip address
xconnect 192.0.2.1 100 pw-class pw-iw-eth
  no shut
end

```

The following example shows how to configure QinQ at Ethernet-CE and Ethernet-PE in Bridged (Ethernet) mode using legacy CLI:

On Ethernet-CE:

```

configure terminal
interface GigabitEthernet0/1
no ip address
no shut
!
interface GigabitEthernet0/1.10
description Connect to PE2
encapsulation dot1q 10 second-dot1q 20
ip address 192.168.1.2 255.255.255.0
ip irdp
ip irdp maxadvertinterval 4
no shut
end

```

On Ethernet-PE:

```

configure terminal
pseudowire-class pw-iw-eth
encapsulation mpls
interworking Ethernet
!
interface GigabitEthernet1/0/0
no ip address
no shut
!
interface GigabitEthernet1/0/0.10
description Connect to CE2
encapsulation dot1Q 10 second-dot1q 20
no ip address
xconnect 192.0.2.1 100 pw-class pw-iw-eth
no shut
end

```

The following example shows how to configure HDLC-Ethernet interworking using Protocol-Based CLI:

The following example shows how to configure HDLC on HDLC-CE and HDLC-PE in Bridged (Ethernet) mode using protocol-based CLI:

On HDLC-CE:

```

configure terminal
bridge irb
bridge 1 protocol ieee
bridge 1 route ip
!
int BVI1
ip address 192.168.1.1 255.255.255.0
no shut
!
interface Serial2/0:0
description Connect to PE1
encapsulation hdlc
bridge-group 1
no shut
end

```

On HDLC-PE:

```

configure terminal
interface Serial0/1/0:0
description Connect to CE1
encapsulation hdlc

```

```

no ip address
no shutdown
!
Interface pseudowire101
encapsulation mpls
neighbor 192.0.2.3 100
signaling protocol ldp
no shutdown
l2vpn xconnect context foohdlc
interworking ethernet
member Serial0/1/0:0
member pseudowire101
no shutdown
end

```

The following example shows how to configure Ethernet on Ethernet-CE and Ethernet-PE - Bridged (Ethernet) mode using protocol-based CLI:

On Ethernet-CE:

```

configure terminal
interface GigabitEthernet0/1
description Connect to PE2
ip address 192.168.1.2 255.255.255.0
ip irdp
ip irdp maxadvertinterval 4
no shutdown
end

```

On Ethernet-PE:

```

configure terminal
interface GigabitEthernet1/0/0
description Connect to CE2
no ip address
no shutdown
!
Interface pseudowire101
encapsulation mpls
neighbor 192.0.2.1 100
signaling protocol ldp
no shutdown
!
l2vpn xconnect context fooeth
interworking ethernet
member GigabitEthernet1/0/0
member pseudowire101
no shutdown
end

```

The following example shows how to configure VLAN on Ether-CE and Ethernet-PE in Bridged (Ethernet) mode using protocol-based CLI:

On Ethernet-CE:

```

configure terminal
!
interface GigabitEthernet0/1
no ip address
no shutdown
!
interface GigabitEthernet0/1.10
encapsulation dot1q 10

```

```

description Connect to PE2
ip address 192.168.1.2 255.255.255.0
ip irdp
ip irdp maxadvertinterval 4
no shut
end

```

On Ethernet-PE:

```

configure terminal
!
interface GigabitEthernet1/0/0
no ip address
no shut
!
interface GigabitEthernet1/0/0.10
description Connect to CE2
encapsulation dot1q 10
no ip address
no shut
!
Interface pseudowire101
encapsulation mpls
neighbor 192.0.2.1 100
signaling protocol ldp
no shut
!
l2vpn xconnect context foovlan
interworking ethernet
member GigabitEthernet1/0/0.10
member pseudowire101
no shut
end

```

The following example shows how to configure QinQ on Ethernet-CE and Ethernet-PE in Bridged (Ethernet) mode using protocol-based CLI:

Ethernet-CE:

```

configure terminal
!
interface GigabitEthernet0/1
no ip address
no shut
!
interface GigabitEthernet0/1.10
description Connect to PE2
encapsulation dot1q 10 second-dot1q 20
ip address 192.168.1.2 255.255.255.0
ip irdp
ip irdp maxadvertinterval 4
no shut
end

```

Ethernet-PE:

```

configure terminal
!
interface GigabitEthernet1/0/0
no ip address
no shut
!
interface GigabitEthernet1/0/0.10

```

```

description Connect to CE2
encapsulation dot1q 10 second-dot1q 20
no ip address
no shut
!
Interface pseudowire101
encapsulation mpls
neighbor 192.0.2.1 100
signaling protocol ldp
no shut
!
l2vpn xconnect context fooqing
interworking ethernet
member GigabitEthernet1/0/0.10
member pseudowire101
no shut
end

```

Example: Verifying the Configuration for HDLC-Ethernet Interworking

Use the following **show** commands to verify the configuration for HDLC-Ethernet interworking:

Port mode

The following example shows how to verify the HDLC configuration on PE:

```

Router# show mpls l2transport vc
-----
Local intf      Local circuit      Dest address      VC ID      Status
-----
Se0/1/0:0      HDLC                104.0.0.1         101        UP

```

```

Router# show mpls l2transport vc detail
Local interface: Se0/1/0:0 up, line protocol up, HDLC up
  Interworking type is Ethernet
  Destination address: 104.0.0.1, VC ID: 101, VC status: up
  Output interface: Fa0/0/1, imposed label stack {20 22}
  Preferred path: not configured
  Default path: active
  Next hop: 10.1.1.2
  Create time: 00:00:19, last status change time: 00:00:15
  Last label FSM state change time: 00:00:15
  Signaling protocol: LDP, peer 104.0.0.1:0 up
  Targeted Hello: 102.0.0.1(LDP Id) -> 104.0.0.1, LDP is UP
  Graceful restart: configured and enabled
  Non stop routing: not configured and not enabled
  Status TLV support (local/remote) : enabled/supported
  LDP route watch : enabled
  Label/status state machine : established, LruRru
  Last local dataplane status rcvd: No fault
  Last BFD dataplane status rcvd: Not sent
  Last BFD peer monitor status rcvd: No fault
  Last local AC circuit status rcvd: No fault
  Last local AC circuit status sent: No fault
  Last local PW i/f circ status rcvd: No fault
  Last local LDP TLV status sent: No fault
  Last remote LDP TLV status rcvd: No fault
  Last remote LDP ADJ status rcvd: No fault
  MPLS VC labels: local 33, remote 22
  Group ID: local 0, remote 0
  MTU: local 1500, remote 1500
  Remote interface description: Connect to CE2
  Sequencing: receive disabled, send disabled
  Control Word: On
  SSO Descriptor: 104.0.0.1/101, local label: 33

```

Example: Verifying the Configuration for HDLC-Ethernet Interworking

```

Dataplane:
  SSM segment/switch IDs: 4274/4273 (used), PWID: 26
VC statistics:
  transit packet totals: receive 3, send 6
  transit byte totals:   receive 162, send 366
  transit packet drops: receive 0, seq error 0, send 0
Router# show l2vpn atom vc

```

Interface	Peer ID	VC ID	Service		Status
			Type	Name	
pw101	104.0.0.1	101	p2p	foo101	UP

```

Router# show l2vpn atom vc detail
pseudowire101 is up, VC status is up PW type: Ethernet
  Create time: 00:00:18, last status change time: 00:00:14
  Last label FSM state change time: 00:00:14
  Destination address: 104.0.0.1 VC ID: 101
  Output interface: Fa0/0/1, imposed label stack {16 17}
  Preferred path: not configured
  Default path: active
  Next hop: 10.1.1.2
Member of xconnect service foo101
  Associated member Se0/1/0:0 is up, status is up
  Interworking type is Ethernet
  Service id: 0xde000002
Signaling protocol: LDP, peer 104.0.0.1:0 up
  Targeted Hello: 102.0.0.1(LDP Id) -> 104.0.0.1, LDP is UP
  Graceful restart: configured and enabled
  Non stop routing: not configured and not enabled
  PWid FEC (128), VC ID: 101
  Status TLV support (local/remote)           : enabled/supported
  LDP route watch                            : enabled
  Label/status state machine                  : established, LruRru
  Local dataplane status received             : No fault
  BFD dataplane status received               : Not sent
  BFD peer monitor status received            : No fault
  Status received from access circuit         : No fault
  Status sent to access circuit                : No fault
  Status received from pseudowire i/f        : No fault
  Status sent to network peer                 : No fault
  Status received from network peer           : No fault
  Adjacency status of remote peer             : No fault
Sequencing: receive disabled, send disabled
Bindings
  Parameter      Local                               Remote
  -----
  Label          18                               17
  Group ID       0                               0
  Interface      Connect to CE1                       Connect to CE2
  MTU            1500                               1500
  Control word   on (configured: autosense)           on
  PW type        Ethernet                       Ethernet
  VCCV CV type   0x02                               0x02
                 LSPV [2]                               LSPV [2]
  VCCV CC type   0x07                               0x07
                 CW [1], RA [2], TTL [3]           CW [1], RA [2], TTL [3]
  Status TLV     enabled                               supported
SSO Descriptor: 104.0.0.1/101, local label: 18
Dataplane:
  SSM segment/switch IDs: 4106/4105 (used), PWID: 2
Rx Counters
  3 input transit packets, 162 bytes
  0 drops, 0 seq err
Tx Counters

```

5 output transit packets, 305 bytes
0 drops

The following example shows how to verify the Ethernet configuration on PE:

```
Router# show mpls l2transport vc
Local intf   Local circuit          Dest address   VC ID   Status
-----
Gi1/0/0     Ethernet               102.0.0.1     101     UP
```

```
Router# show mpls l2transport vc detail
Local interface: Gi1/0/0 up, line protocol up, Ethernet up
  Destination address: 102.0.0.1, VC ID: 101, VC status: up
  Output interface: Fa0/0/1, imposed label stack {19 33}
  Preferred path: not configured
  Default path: active
  Next hop: 11.1.1.1
Create time: 00:00:22, last status change time: 00:00:19
  Last label FSM state change time: 00:00:19
Signaling protocol: LDP, peer 102.0.0.1:0 up
  Targeted Hello: 104.0.0.1(LDP Id) -> 102.0.0.1, LDP is UP
Graceful restart: configured and enabled
Non stop routing: not configured and not enabled
Status TLV support (local/remote) : enabled/supported
  LDP route watch : enabled
  Label/status state machine : established, LruRru
  Last local dataplane status rcvd: No fault
  Last BFD dataplane status rcvd: Not sent
  Last BFD peer monitor status rcvd: No fault
  Last local AC circuit status rcvd: No fault
  Last local AC circuit status sent: No fault
  Last local PW i/f circ status rcvd: No fault
  Last local LDP TLV status sent: No fault
  Last remote LDP TLV status rcvd: No fault
  Last remote LDP ADJ status rcvd: No fault
MPLS VC labels: local 22, remote 33
Group ID: local 0, remote 0
MTU: local 1500, remote 1500
Remote interface description: Connect to CE1
Sequencing: receive disabled, send disabled
Control Word: On
SSO Descriptor: 102.0.0.1/101, local label: 22
Dataplane:
  SSM segment/switch IDs: 4574/4573 (used), PWID: 80
VC statistics:
  transit packet totals: receive 9, send 5
  transit byte totals: receive 315, send 380
  transit packet drops: receive 0, seq error 0, send 0
```

```
Router# show l2vpn atom vc
Interface Peer ID      VC ID   Service Type Name      Status
-----
pw101     102.0.0.1   101     p2p    foo101    UP
```

```
Router# show l2vpn atom vc detail
pseudowire101 is up, VC status is up PW type: Ethernet
  Create time: 00:00:23, last status change time: 00:00:20
  Last label FSM state change time: 00:00:20
  Destination address: 102.0.0.1 VC ID: 101
  Output interface: Fa0/0/1, imposed label stack {18 18}
  Preferred path: not configured
  Default path: active
  Next hop: 11.1.1.1
Member of xconnect service foo101
  Associated member Gi1/0/0 is up, status is up
  Interworking type is Like2Like
```

Example: Verifying the Configuration for HDLC-Ethernet Interworking

```

Service id: 0xb5000004
Signaling protocol: LDP, peer 102.0.0.1:0 up
Targeted Hello: 104.0.0.1(LDP Id) -> 102.0.0.1, LDP is UP
Graceful restart: configured and enabled
Non stop routing: not configured and not enabled
Pwid FEC (128), VC ID: 101
Status TLV support (local/remote)      : enabled/supported
  LDP route watch                       : enabled
  Label/status state machine            : established, LruRru
  Local dataplane status received       : No fault
  BFD dataplane status received         : Not sent
  BFD peer monitor status received      : No fault
  Status received from access circuit   : No fault
  Status sent to access circuit         : No fault
  Status received from pseudowire i/f   : No fault
  Status sent to network peer           : No fault
  Status received from network peer     : No fault
  Adjacency status of remote peer      : No fault
Sequencing: receive disabled, send disabled
Bindings
  Parameter      Local                               Remote
  -----
Label            17                               18
Group ID         0                               0
Interface        Connect to CE2                 Connect to CE1
MTU              1500                            1500
Control word on (configured: autosense) on
PW type          Ethernet                       Ethernet
VCCV CV type 0x02
                  LSPV [2]                       LSPV [2]
VCCV CC type 0x07
                  CW [1], RA [2], TTL [3]         CW [1], RA [2], TTL [3]
Status TLV      enabled                         supported
SSO Descriptor: 102.0.0.1/101, local label: 17
Dataplane:
  SSM segment/switch IDs: 4126/4125 (used), PWID: 4
Rx Counters
  5 input transit packets, 175 bytes
  0 drops, 0 seq err
Tx Counters
  3 output transit packets, 228 bytes
  0 drops

```

VLAN (dot1q) mode

The following example shows how to verify the HDLC configuration on PE:

```

Router# show mpls l2transport vc
Local intf      Local circuit      Dest address      VC ID      Status
-----
Se0/1/0:0      HDLC                104.0.0.1        138        UP
Router# show mpls l2transport vc detail
Local interface: Se0/1/0:0 up, line protocol up, HDLC up
Interworking type is Ethernet
Destination address: 104.0.0.1, VC ID: 138, VC status: up
Output interface: Fa0/0/1, imposed label stack {20 53}
Preferred path: not configured
Default path: active
Next hop: 10.1.1.2
Create time: 00:00:19, last status change time: 00:00:15
Last label FSM state change time: 00:00:15
Signaling protocol: LDP, peer 104.0.0.1:0 up
Targeted Hello: 102.0.0.1(LDP Id) -> 104.0.0.1, LDP is UP
Graceful restart: configured and enabled

```

```

Non stop routing: not configured and not enabled
Status TLV support (local/remote) : enabled/supported
  LDP route watch                  : enabled
  Label/status state machine       : established, LruRru
  Last local dataplane status rcvd: No fault
  Last BFD dataplane status rcvd: Not sent
  Last BFD peer monitor status rcvd: No fault
  Last local AC circuit status rcvd: No fault
  Last local AC circuit status sent: No fault
  Last local PW i/f circ status rcvd: No fault
  Last local LDP TLV status sent: No fault
  Last remote LDP TLV status rcvd: No fault
  Last remote LDP ADJ status rcvd: No fault
MPLS VC labels: local 35, remote 53
Group ID: local 0, remote 0
MTU: local 1500, remote 1500
Remote interface description: Connect to CE2
Sequencing: receive disabled, send disabled
Control Word: On
SSO Descriptor: 104.0.0.1/138, local label: 35
Dataplane:
  SSM segment/switch IDs: 4486/4485 (used), PWID: 65
VC statistics:
  transit packet totals: receive 4, send 3
  transit byte totals:  receive 1036, send 183
  transit packet drops: receive 0, seq error 0, send 0

```

Router# **show l2vpn atom vc**

Interface	Peer ID	VC ID	Service Type	Service Name	Status
pwl38	104.0.0.1	138	p2p	fool38	UP

Router# **show l2vpn atom vc detail**

```

pseudowire138 is up, VC status is up PW type: Ethernet
Create time: 00:00:18, last status change time: 00:00:14
Last label FSM state change time: 00:00:14
Destination address: 104.0.0.1 VC ID: 138
Output interface: Fa0/0/1, imposed label stack {16 30}
Preferred path: not configured
Default path: active
Next hop: 10.1.1.2
Member of xconnect service fool38
Associated member Se0/1/0:0 is up, status is up
Interworking type is Ethernet
Service id: 0x4000027
Signaling protocol: LDP, peer 104.0.0.1:0 up
Targeted Hello: 102.0.0.1(LDP Id) -> 104.0.0.1, LDP is UP
Graceful restart: configured and enabled
Non stop routing: not configured and not enabled
PWid FEC (128), VC ID: 138
Status TLV support (local/remote) : enabled/supported
  LDP route watch                  : enabled
  Label/status state machine       : established, LruRru
  Local dataplane status received  : No fault
  BFD dataplane status received    : Not sent
  BFD peer monitor status received  : No fault
  Status received from access circuit : No fault
  Status sent to access circuit     : No fault
  Status received from pseudowire i/f : No fault
  Status sent to network peer       : No fault
  Status received from network peer  : No fault
  Adjacency status of remote peer   : No fault
Sequencing: receive disabled, send disabled
Bindings
  Parameter   Local                               Remote

```

Example: Verifying the Configuration for HDLC-Ethernet Interworking

```

-----
Label          20                               30
Group ID      0                               0
Interface      Connect to CE1                          Connect to CE2
MTU           1500                          1500
Control word  on (configured: autosense)      on
PW type       Ethernet                      Ethernet
VCCV CV type  0x02                          0x02
              LSPV [2]                      LSPV [2]
VCCV CC type  0x07                          0x07
              CW [1], RA [2], TTL [3]        CW [1], RA [2], TTL [3]
Status TLV    enabled                      supported
SSO Descriptor: 104.0.0.1/138, local label: 20
Dataplane:
  SSM segment/switch IDs: 4313/4312 (used), PWID: 41
Rx Counters
  2 input transit packets, 108 bytes
  0 drops, 0 seq err
Tx Counters
  3 output transit packets, 183 bytes
  0 drops

```

The following example shows how to verify the VLAN configuration on PE:

```

Router# show mpls l2transport vc
-----
Local intf    Local circuit    Dest address    VC ID    Status
-----
Gi1/0/0.10   Eth VLAN 10     102.0.0.1     138     UP
Router# show mpls l2transport vc detail
Local interface: Gi1/0/0.10 up, line protocol up, Eth VLAN 10 up
Interworking type is Ethernet
Destination address: 102.0.0.1, VC ID: 138, VC status: up
Output interface: Fa0/0/1, imposed label stack {19 35}
Preferred path: not configured
Default path: active
Next hop: 11.1.1.1
Create time: 00:00:22, last status change time: 00:00:20
Last label FSM state change time: 00:00:20
Signaling protocol: LDP, peer 102.0.0.1:0 up
Targeted Hello: 104.0.0.1(LDP Id) -> 102.0.0.1, LDP is UP
Graceful restart: configured and enabled
Non stop routing: not configured and not enabled
Status TLV support (local/remote) : enabled/supported
LDP route watch : enabled
Label/status state machine : established, LruRru
Last local dataplane status rcvd: No fault
Last BFD dataplane status rcvd: Not sent
Last BFD peer monitor status rcvd: No fault
Last local AC circuit status rcvd: No fault
Last local AC circuit status sent: No fault
Last local PW i/f circ status rcvd: No fault
Last local LDP TLV status sent: No fault
Last remote LDP TLV status rcvd: No fault
Last remote LDP ADJ status rcvd: No fault
MPLS VC labels: local 53, remote 35
Group ID: local 0, remote 0
MTU: local 1500, remote 1500
Remote interface description: Connect to CE1
Sequencing: receive disabled, send disabled
Control Word: On
SSO Descriptor: 102.0.0.1/138, local label: 53
Dataplane:
  SSM segment/switch IDs: 4784/4783 (used), PWID: 117
VC statistics:

```

```

transit packet totals: receive 6, send 6
transit byte totals:  receive 234, send 1276
transit packet drops: receive 0, seq error 0, send 0
Router# show l2vpn atom vc

```

Interface	Peer ID	VC ID	Service Type	Service Name	Status
pwl38	102.0.0.1	138	p2p	fool38	UP

```

Router# show l2vpn atom vc detail
pseudowire138 is up, VC status is up PW type: Ethernet
  Create time: 00:00:23, last status change time: 00:00:20
  Last label FSM state change time: 00:00:20
  Destination address: 102.0.0.1 VC ID: 138
  Output interface: Fa0/0/1, imposed label stack {18 20}
  Preferred path: not configured
  Default path: active
  Next hop: 11.1.1.1
Member of xconnect service fool38
  Associated member Gil/0/0.10 is up, status is up
  Interworking type is Ethernet
  Service id: 0x7b000029
Signaling protocol: LDP, peer 102.0.0.1:0 up
  Targeted Hello: 104.0.0.1(LDP Id) -> 102.0.0.1, LDP is UP
  Graceful restart: configured and enabled
  Non stop routing: not configured and not enabled
  PWid FEC (128), VC ID: 138
  Status TLV support (local/remote) : enabled/supported
    LDP route watch : enabled
    Label/status state machine : established, LruRru
    Local dataplane status received : No fault
    BFD dataplane status received : Not sent
    BFD peer monitor status received : No fault
    Status received from access circuit : No fault
    Status sent to access circuit : No fault
    Status received from pseudowire i/f : No fault
    Status sent to network peer : No fault
    Status received from network peer : No fault
    Adjacency status of remote peer : No fault
Sequencing: receive disabled, send disabled
Bindings
  Parameter Local Remote
  -----
  Label 30 20
  Group ID 0 0
  Interface Connect to CE2 Connect to CE1
  MTU 1500 1500
  Control word on (configured: autosense) on
  PW type Ethernet Ethernet
  VCCV CV type 0x02 0x02
    LSPV [2] LSPV [2]
  VCCV CC type 0x07 0x07
    CW [1], RA [2], TTL [3] CW [1], RA [2], TTL [3]
  Status TLV enabled supported
SSO Descriptor: 102.0.0.1/138, local label: 30
Dataplane:
  SSM segment/switch IDs: 4333/4332 (used), PWID: 41
Rx Counters
  8 input transit packets, 312 bytes
  0 drops, 0 seq err
Tx Counters
  5 output transit packets, 380 bytes
  0 drops

```

QinQ mode

The following example shows how to verify HDLC configuration on PE:

```

Router# show mpls l2transport vc
-----
Local intf      Local circuit      Dest address      VC ID      Status
-----
Se0/1/0:0      HDLC               104.0.0.1        145        UP
Router# show mpls l2transport vc detail
Local interface: Se0/1/0:0 up, line protocol up, HDLC up
  Interworking type is Ethernet
  Destination address: 104.0.0.1, VC ID: 145, VC status: up
  Output interface: Fa0/0/1, imposed label stack {20 25}
  Preferred path: not configured
  Default path: active
  Next hop: 10.1.1.2
  Create time: 00:00:20, last status change time: 00:00:15
  Last label FSM state change time: 00:00:15
  Signaling protocol: LDP, peer 104.0.0.1:0 up
  Targeted Hello: 102.0.0.1(LDP Id) -> 104.0.0.1, LDP is UP
  Graceful restart: configured and enabled
  Non stop routing: not configured and not enabled
  Status TLV support (local/remote)   : enabled/supported
  LDP route watch                     : enabled
  Label/status state machine          : established, LruRru
  Last local dataplane status rcvd: No fault
  Last BFD dataplane status rcvd: Not sent
  Last BFD peer monitor status rcvd: No fault
  Last local AC circuit status rcvd: No fault
  Last local AC circuit status sent: No fault
  Last local PW i/f circ status rcvd: No fault
  Last local LDP TLV status sent: No fault
  Last remote LDP TLV status rcvd: No fault
  Last remote LDP ADJ status rcvd: No fault
  MPLS VC labels: local 27, remote 25
  Group ID: local 0, remote 0
  MTU: local 1500, remote 1500
  Remote interface description: Connect to CE2
  Sequencing: receive disabled, send disabled
  Control Word: On
  SSO Descriptor: 104.0.0.1/145, local label: 27
  Dataplane:
    SSM segment/switch IDs: 4521/4520 (used), PWID: 72
  VC statistics:
    transit packet totals: receive 4, send 7
    transit byte totals: receive 216, send 427
    transit packet drops: receive 0, seq error 0, send 0
Router# show mpls l2vpn atom vc
-----
Interface Peer ID      VC ID      Service Type Name      Status
-----
pw145     104.0.0.1    145       p2p     foo145    UP
Router# show mpls l2vpn atom vc detail
pseudowire145 is up, VC status is up PW type: Ethernet
  Create time: 00:00:18, last status change time: 00:00:13
  Last label FSM state change time: 00:00:13
  Destination address: 104.0.0.1 VC ID: 145
  Output interface: Fa0/0/1, imposed label stack {16 33}
  Preferred path: not configured
  Default path: active
  Next hop: 10.1.1.2
  Member of xconnect service foo145
  Associated member Se0/1/0:0 is up, status is up
  Interworking type is Ethernet

```

```

Service id: 0x2e
Signaling protocol: LDP, peer 104.0.0.1:0 up
Targeted Hello: 102.0.0.1(LDP Id) -> 104.0.0.1, LDP is UP
Graceful restart: configured and enabled
Non stop routing: not configured and not enabled
PWid FEC (128), VC ID: 145
Status TLV support (local/remote)      : enabled/supported
  LDP route watch                       : enabled
  Label/status state machine            : established, LruRru
  Local dataplane status received       : No fault
  BFD dataplane status received         : Not sent
  BFD peer monitor status received      : No fault
  Status received from access circuit   : No fault
  Status sent to access circuit          : No fault
  Status received from pseudowire i/f   : No fault
  Status sent to network peer           : No fault
  Status received from network peer     : No fault
  Adjacency status of remote peer      : No fault
Sequencing: receive disabled, send disabled
Bindings
Parameter      Local                               Remote
-----
Label          33                               33
Group ID       0                               0
Interface      Connect to CE1                       Connect to CE2
MTU            1500                              1500
Control word on (configured: autosense) on
PW type        Ethernet                  Ethernet
VCCV CV type 0x02                       0x02
              LSPV [2]                  LSPV [2]
VCCV CC type 0x07                       0x07
              CW [1], RA [2], TTL [3]    CW [1], RA [2], TTL [3]
Status TLV     enabled                  supported
SSO Descriptor: 104.0.0.1/145, local label: 33
Dataplane:
  SSM segment/switch IDs: 4345/4344 (used), PWID: 48
Rx Counters
  2 input transit packets, 108 bytes
  0 drops, 0 seq err
Tx Counters
  3 output transit packets, 183 bytes
  0 drops

```

The following example shows how to verify the Qinq configuration on PE:

```

Router# show mpls l2transport vc
Local intf      Local circuit          Dest address      VC ID      Status
-----
Gi1/0/0.10     Eth VLAN 10/20        102.0.0.1        145        UP
Router# show mpls l2transport vc detail
Local interface: Gi1/0/0.10 up, line protocol up, Eth VLAN 10/20 up
Interworking type is Ethernet
Destination address: 102.0.0.1, VC ID: 145, VC status: up
Output interface: Fa0/0/1, imposed label stack {19 27}
Preferred path: not configured
Default path: active
Next hop: 11.1.1.1
Create time: 00:00:23, last status change time: 00:00:21
Last label FSM state change time: 00:00:21
Signaling protocol: LDP, peer 102.0.0.1:0 up
Targeted Hello: 104.0.0.1(LDP Id) -> 102.0.0.1, LDP is UP
Graceful restart: configured and enabled
Non stop routing: not configured and not enabled
Status TLV support (local/remote) : enabled/supported

```

Example: Verifying the Configuration for HDLC-Ethernet Interworking

```

LDP route watch                : enabled
Label/status state machine     : established, LruRru
Last local dataplane status rcvd: No fault
Last BFD dataplane status rcvd: Not sent
Last BFD peer monitor status rcvd: No fault
Last local AC circuit status rcvd: No fault
Last local AC circuit status sent: No fault
Last local PW i/f circ status rcvd: No fault
Last local LDP TLV status sent: No fault
Last remote LDP TLV status rcvd: No fault
Last remote LDP ADJ status rcvd: No fault
MPLS VC labels: local 25, remote 27
Group ID: local 0, remote 0
MTU: local 1500, remote 1500
Remote interface description: Connect to CE1
Sequencing: receive disabled, send disabled
Control Word: On
SSO Descriptor: 102.0.0.1/145, local label: 25
Dataplane:
  SSM segment/switch IDs: 4815/4814 (used), PWID: 124
VC statistics:
  transit packet totals: receive 10, send 6
  transit byte totals:  receive 430, send 456
  transit packet drops: receive 0, seq error 0, send 0
Router# show l2vpn atom vc

```

Interface	Peer ID	VC ID	Service Type	Service Name	Status
pw145	102.0.0.1	145	p2p	fool45	UP

```

Router# show l2vpn atom vc detail
pseudowire145 is up, VC status is up PW type: Ethernet
Create time: 00:00:23, last status change time: 00:00:19
Last label FSM state change time: 00:00:19
Destination address: 102.0.0.1 VC ID: 145
Output interface: Fa0/0/1, imposed label stack {18 33}
Preferred path: not configured
Default path: active
Next hop: 11.1.1.1
Member of xconnect service fool45
Associated member Gil/0/0.10 is up, status is up
Interworking type is Ethernet
Service id: 0xed000030
Signaling protocol: LDP, peer 102.0.0.1:0 up
Targeted Hello: 104.0.0.1(LDP Id) -> 102.0.0.1, LDP is UP
Graceful restart: configured and enabled
Non stop routing: not configured and not enabled
PWid FEC (128), VC ID: 145
Status TLV support (local/remote) : enabled/supported
LDP route watch                  : enabled
Label/status state machine       : established, LruRru
Local dataplane status received  : No fault
BFD dataplane status received    : Not sent
BFD peer monitor status received : No fault
Status received from access circuit : No fault
Status sent to access circuit    : No fault
Status received from pseudowire i/f : No fault
Status sent to network peer      : No fault
Status received from network peer : No fault
Adjacency status of remote peer  : No fault
Sequencing: receive disabled, send disabled
Bindings
Parameter  Local          Remote
-----
Label      33                33

```



```

Group ID          0                               0
Interface         Connect to CE2                 Connect to CE1
MTU               1500                           1500
Control word on (configured: autosense)           on
PW type           Ethernet                       Ethernet
VCCV CV type     0x02                           0x02
                  LSPV [2]                       LSPV [2]
VCCV CC type     0x07                           0x07
                  CW [1], RA [2], TTL [3]         CW [1], RA [2], TTL [3]
Status TLV       enabled                         supported
SSO Descriptor:  102.0.0.1/145, local label: 33
Dataplane:
  SSM segment/switch IDs: 4361/4360 (used), PWID: 48
Rx Counters
  8 input transit packets, 344 bytes
  0 drops, 0 seq err
Tx Counters
  5 output transit packets, 380 bytes
  0 drops

```

Example: HDLC-Dot1Q Interworking

The following example shows how to configure HDLC-dot1q interworking:

Short form

On HDLC-PE:

```

configure terminal
template type pseudowire hdlc-vlan1-tmp
encapsulation mpls
signaling protocol ldp

l2vpn xconnect context hdlc-vlan1
interworking ethernet
member Serial0/2/0:3
member pseudowire101 192.0.2.3 107 template hdlc-vlan1-tmp
no shutdown
end

```

On Ethernet-PE:

```

configure terminal
interface FastEthernet0/0/0.16
description Connect to CE2
encapsulation dot1q 16
no ip address
no shut
!
template type pseudowire hdlc-vlan1-tmp
encapsulation mpls
signaling protocol ldp

l2vpn xconnect context hdlc-vlan1
interworking ethernet
member FastEthernet0/0/0.16
member pseudowire101 192.0.2.1 107 template hdlc-vlan1-tmp
no shutdown
end

```

Long form

On HDLC-PE:

```

configure terminal
template type pseudowire hdlc-vlan1
 encapsulation mpls
!
interface pseudowire107
 source template type pseudowire hdlc-vlan1
 encapsulation mpls
 neighbor 192.0.2.3 107
 signaling protocol ldp
 no shut
!
l2vpn xconnect context hdlc-vlan1-con
 interworking ethernet
 member Serial0/2/0:3
 member pseudowire107
 no shutdown
end

```

On Ethernet-PE:

```

configure terminal
interface FastEthernet0/0/0.16
 description Connect to CE2
 encapsulation dot1q 16
 no ip address
 no shut
!
template type pseudowire hdlc-vlan1
 encapsulation mpls
!
interface pseudowire107
 source template type pseudowire hdlc-vlan1
 encapsulation mpls
 neighbor 192.0.2.1 107
 signaling protocol ldp
 no shut
!
l2vpn xconnect context hdlc-vlan1-con
 interworking ethernet
 member FastEthernet0/0/0.16
 member pseudowire107
 no shutdown
end

```

Additional References

The following sections provide references related to the Frame Relay-to-ATM Bridged Interworking and xconnect support on GEC (VPWS) features.

Related Documents

Related Topic	Document Title
Basics of MPLS	{start cross reference}MPLS: Basic MPLS Configuration Guide, Cisco IOS XE Release 3S {end cross reference}

Related Topic	Document Title
MPLS Layer 2 VPNs	{start cross reference}MPLS Layer 2 VPNs Configuration Guide, Cisco IOS XE Release 3S{end cross reference}
Cisco IOS Configuration Fundamentals	{start cross reference}Cisco IOS Configuration Fundamentals Command Reference{end cross reference}

Standards

Standard	Title
No new or modified standards are supported by this feature.	—

MIBs

MIB	MIBs Link
<ul style="list-style-type: none"> • CISCO-IETF-PW-MIB • CISCO-IETF-PW-MPLS-MIB 	To locate and download MIBs for selected platforms, Cisco IOS releases, and feature sets, use the Cisco MIB Locator found at the following URL: {start hypertext}http://www.cisco.com/go/mibs{end hypertext}

RFCs

RFC ¹	Title
RFC 2684	Multiprotocol Encapsulation over ATM Adaptation Layer 5
RFC 2427	Multiprotocol Interconnect over Frame Relay

{start footnote}Not all the supported RFCs are listed.{end footnote}

Technical Assistance

Description	Link
<p>The Cisco Support website provides extensive online resources, including documentation and tools for troubleshooting and resolving technical issues with Cisco products and technologies.</p> <p>To receive security and technical information about your products, you can subscribe to various services, such as the Product Alert Tool (accessed from Field Notices), the Cisco Technical Services Newsletter, and Really Simple Syndication (RSS) Feeds.</p> <p>Access to most tools on the Cisco Support website requires a Cisco.com user ID and password.</p>	<p>{start hypertext}http://www.cisco.com/cisco/web/support/index.html{end hypertext}</p>

Feature Information for Configuring MPLS Layer 2 VPNs

{start cross reference} Table 17-2 {end cross reference} lists the features in this module and provides links to specific configuration information. Only features that were introduced or modified in Cisco IOS Release 3.6.0S or a later release appear in the table.

Not all commands may be available in your Cisco IOS software release. For release information about a specific command, see the corresponding command reference documentation.

Use the Cisco Feature Navigator to find information about platform support and software image support. The Cisco Feature Navigator enables you to determine which Cisco IOS and Cisco Catalyst operating system software images support a specific software release, feature set, or platform. To access the Cisco Feature Navigator, go to {start hypertext}http://www.cisco.com/go/cfn{end hypertext}. An account on Cisco.com is not required.

Table 2: Feature Information for Configuring MPLS Layer 2 VPNs

Feature Name	Releases	Feature Information
Frame Relay to ATM Bridged Interworking	3.6.0S	<p>The Frame Relay to ATM Bridged Interworking feature provides interoperability between the Frame Relay attachment VC and the ATM attachment VC connected to different PE routers. The bridged encapsulation corresponding to the bridged (Ethernet) interworking mechanism is used. The Ethernet frames are carried through the MPLS network using Ethernet over MPLS (EoMPLS).</p> <p>In Cisco IOS XE Release 3.6.0S, this feature was implemented on the Cisco ASR 1000 Series Aggregation Services Routers.</p> <p>The following sections provide information about this feature:</p> <ul style="list-style-type: none"> {start cross reference}Frame Relay DLCI-to-ATM AAL5SNAP Bridged Interworking{end cross reference} {start cross reference}Configuring Frame Relay DLCI-to-ATM AAL5SNAP Bridged Interworking{end cross reference}
xconnect support on GEC (VPWS) on ASR1000	3.6.0S	<p>The Xconnect Support on GEC (VPWS) on ASR1000 feature enables the service providers to supply connectivity between customer sites with existing data link layer (Layer 2) networks by using a single, integrated, packet-based network infrastructure—a Cisco MPLS network. Instead of separate networks with network management environments, service providers can deliver Layer 2 connections over an MPLS backbone.</p> <p>In Cisco IOS XE Release 3.6.0S, this feature was implemented on the ASR 1000 Series Aggregation Services Routers.</p> <p>The following sections provide information about this feature:</p> <ul style="list-style-type: none"> {start cross reference}Gigabit EtherChannel for Virtual Private Wire Service{end cross reference} {start cross reference}Configuring Gigabit EtherChannel for Virtual Private Wire Service{end cross reference}
Reverse Layer 2 Gateway Protocol	3.8.0S	<p>Reverse L2GP (R-L2GP) is a variation of L2GP. In case of R-L2GP, the pseudo information of the R-L2GP is transmitted by nPEs, instead of uPEs. R-L2GP provides a mechanism to send out static preconfigured BPDUs on each ring access port of nPEs to stimulate a per-access ring instantiation of the protocol. R-L2GP enables the PEs to avoid the burden of running Multiple-instance Spanning Tree Protocol (MST) when multiple independent access networks that run MST connect to a pair of redundant PEs. In order for this to work, the pair of nPEs are programmed to send out BPDUs on the access ring ports in such a way that they appear to be either:</p> <ul style="list-style-type: none"> The root bridge itself (the bridge with the lowest bridge id/priority). The bridge with the second lowest bridge ID/priority, and with a 0 cost path to the root. <p>The following sections provide information about this feature:</p> <ul style="list-style-type: none"> {start cross reference}Reverse Layer 2 Gateway Protocol{end cross reference} {start cross reference}Configuring the R-L2GP{end cross reference}

Feature Name	Releases	Feature Information
HDLC-Ethernet Interworking	3.13.0S	<p>High-Level Data Link Control (HDLC)-Ethernet over MPLS is part of Any Transport over MPLS (AToM) solution. HDLC and Ethernet are two link-layer transport systems that utilize the AToM architecture. The feature describes how these two transport system can communicate with each other using the AToM framework.</p> <p>The following sections provide information about this feature:</p> <ul style="list-style-type: none"> {start cross reference}High-Level Data Link Control-Ethernet Interworking{end cross reference} {start cross reference}Configuring HDLC-Ethernet Interworking{end cross reference}

Glossary

ATM—Asynchronous Transfer Mode. A method of data transportation, whereby fixed-length packets are sent over a switched network. The method's ability to ensure reliable delivery of packets at a high rate makes it suitable for carrying voice, video, and data.

AToM—Any Transport over MPLS. AToM is a solution for transporting Layer 2 packets over an MPLS backbone. AToM enables service providers to supply connectivity between customer sites with existing data link layer (Layer 2) networks by using a single, integrated, packet-based network infrastructure—a Cisco MPLS network. Instead of separate networks with separate network management environments, service providers can deliver Layer 2 connections over an MPLS backbone.

Dot1q—IEEE 802.1Q is the networking standard that supports virtual LANs (VLANs) on an Ethernet network. The standard defines a system of VLAN tagging for Ethernet frames and the accompanying procedures to be used by bridges and switches in handling such frames.

EoMPLS—Ethernet over MPLS. This technology leverages an existing MPLS backbone network to deliver Transparent LAN Services based on Ethernet connectivity to the customer site.

GEC—Gigabit EtherChannel. A high-performance Ethernet technology that provides gigabit per second transmission rates. It provides a flexible and scalable bandwidth with resiliency and load sharing across links for switches, router interfaces, and servers. Supports up to eight links per channel.

HDLC—High-Level Data Link Control (HDLC) is a bit-oriented code-transparent synchronous data link-layer protocol developed by the International Organization for Standardization (ISO).

MPLS—Multiprotocol Label Switching. A mechanism in high-performance telecommunications networks that directs and carries data from one network node to the next. MPLS makes it easy to create virtual links between distant nodes. It can encapsulate packets of various network protocols.

QinQ—IEEE 802.1ad is an Ethernet networking standard informally known as IEEE 802.1QinQ, and is an amendment to the IEEE standard 802.1Q-1998. The technique is also known as provider bridging, Stacked VLANs, or simply QinQ or Q-in-Q.

VPLS—Virtual Private LAN Service. A method to provide Ethernet-based multipoint-to-multipoint communication over IP and MPLS networks.