



Cisco ASR 9000 Series Aggregation Services Router Overview and Reference Guide

First Published: 2009-03-02

Last Modified: 2019-01-31

Americas Headquarters

Cisco Systems, Inc.
170 West Tasman Drive
San Jose, CA 95134-1706
USA
<http://www.cisco.com>
Tel: 408 526-4000
800 553-NETS (6387)
Fax: 408 527-0883

THE SPECIFICATIONS AND INFORMATION REGARDING THE PRODUCTS IN THIS MANUAL ARE SUBJECT TO CHANGE WITHOUT NOTICE. ALL STATEMENTS, INFORMATION, AND RECOMMENDATIONS IN THIS MANUAL ARE BELIEVED TO BE ACCURATE BUT ARE PRESENTED WITHOUT WARRANTY OF ANY KIND, EXPRESS OR IMPLIED. USERS MUST TAKE FULL RESPONSIBILITY FOR THEIR APPLICATION OF ANY PRODUCTS.

THE SOFTWARE LICENSE AND LIMITED WARRANTY FOR THE ACCOMPANYING PRODUCT ARE SET FORTH IN THE INFORMATION PACKET THAT SHIPPED WITH THE PRODUCT AND ARE INCORPORATED HEREIN BY THIS REFERENCE. IF YOU ARE UNABLE TO LOCATE THE SOFTWARE LICENSE OR LIMITED WARRANTY, CONTACT YOUR CISCO REPRESENTATIVE FOR A COPY.

The Cisco implementation of TCP header compression is an adaptation of a program developed by the University of California, Berkeley (UCB) as part of UCB's public domain version of the UNIX operating system. All rights reserved. Copyright © 1981, Regents of the University of California.

NOTWITHSTANDING ANY OTHER WARRANTY HEREIN, ALL DOCUMENT FILES AND SOFTWARE OF THESE SUPPLIERS ARE PROVIDED "AS IS" WITH ALL FAULTS. CISCO AND THE ABOVE-NAMED SUPPLIERS DISCLAIM ALL WARRANTIES, EXPRESSED OR IMPLIED, INCLUDING, WITHOUT LIMITATION, THOSE OF MERCHANTABILITY, FITNESS FOR A PARTICULAR PURPOSE AND NON-INFRINGEMENT OR ARISING FROM A COURSE OF DEALING, USAGE, OR TRADE PRACTICE.

IN NO EVENT SHALL CISCO OR ITS SUPPLIERS BE LIABLE FOR ANY INDIRECT, SPECIAL, CONSEQUENTIAL, OR INCIDENTAL DAMAGES, INCLUDING, WITHOUT LIMITATION, LOST PROFITS OR LOSS OR DAMAGE TO DATA ARISING OUT OF THE USE OR INABILITY TO USE THIS MANUAL, EVEN IF CISCO OR ITS SUPPLIERS HAVE BEEN ADVISED OF THE POSSIBILITY OF SUCH DAMAGES.

Any Internet Protocol (IP) addresses and phone numbers used in this document are not intended to be actual addresses and phone numbers. Any examples, command display output, network topology diagrams, and other figures included in the document are shown for illustrative purposes only. Any use of actual IP addresses or phone numbers in illustrative content is unintentional and coincidental.

All printed copies and duplicate soft copies of this document are considered uncontrolled. See the current online version for the latest version.

Cisco has more than 200 offices worldwide. Addresses and phone numbers are listed on the Cisco website at www.cisco.com/go/offices.

Cisco and the Cisco logo are trademarks or registered trademarks of Cisco and/or its affiliates in the U.S. and other countries. To view a list of Cisco trademarks, go to this URL: <https://www.cisco.com/c/en/us/about/legal/trademarks.html>. Third-party trademarks mentioned are the property of their respective owners. The use of the word partner does not imply a partnership relationship between Cisco and any other company. (1721R)

© 2016–2019 Cisco Systems, Inc. All rights reserved.



CONTENTS

Preface ix

Audience ix

Documentation Conventions ix

Related Documentation x

Changes to This Document x

Obtaining Documentation and Submitting a Service Request xi

CHAPTER 1

Overview and Physical Description 1

Chassis Physical Overview 1

 Cisco ASR 9010 Router 2

 Cisco ASR 9006 Router 3

 Cisco ASR 9904 Router 4

 Cisco ASR 9906 Router 4

 Cisco ASR 9910 Router 5

 Cisco ASR 9922 Router 5

 Cisco ASR 9912 Router 6

 Field Replaceable Units 7

Rack-Mounting Specifications 8

 Chassis Top-Down View Dimensions 10

 Chassis Slots 17

 Fiber and Interface Cable Management 20

 Routing of DC Power Tray Source Cables 21

 Slot ID Numbering 21

 Cisco ASR 9010 Router 22

 Cisco ASR 9006 Router 22

 Cisco ASR 9904 Router 23

Cisco ASR 9906 Router	23
Cisco ASR 9910 Router	24
Cisco ASR 9912 Router	25
Cisco ASR 9922 Router	26
Route Switch Processor and Route Processor Cards	28
Overview	28
RSP Card Front Panel and Access Ports	28
RSP-440 and RSP-440 Lite Front Panel and Access Ports	30
RSP-880 and RSP880-LT Card Front Panel and Access Ports	34
RSP4-S Card Front Panel and Access Ports	37
RSP5 Card Front Panel and Access Ports	37
RSP5-X Card Front Panel and Access Ports	39
RP Card and RP2 Card Front Panel and Access Ports	41
RP3 Card Front Panel and Access Ports	44
RP3-X Card Front Panel and Access Ports	46
RSP and RP Front Panel Connectors	48
Management Ports	48
Auxiliary (AUX) Port and Console Port	48
Synchronization Ports	48
Alarm Connector	49
SFP/SFP+ Port	49
GPS Interface	49
Inter Chassis Synchronization Port	49
CMP Port	49
USB Port	49
Push Buttons	50
RSP and RP Front Panel Indicators	50
LED Matrix Display	52
LED Matrix Boot Stage and Runtime Display	52
LED Matrix CAN Bus Controller Error Display	55
RSP and RP Card Ejector Levers	55
Serviceability	55
Fabric Controller Card	55
FC Card Front Panel Indicator	57

FC Card Ejector Levers	58
Ethernet Line Cards	58
Line Card Serviceability	58
Line Card Ejector Levers	59
Power System	59
AC and DC Power Modules	59
Cisco ASR 9010 Router Power Modules	59
Cisco ASR 9904 Router Power Modules	60
Cisco ASR 9906 Router Power Modules	61
Cisco ASR 9910 Router Power Modules	62
Cisco ASR 9922 Router Power Modules	67
Cisco ASR 9912 Router Power Modules	67
Cooling System	68
Management and Configuration	70

CHAPTER 2

Functional Description	71
Router Operation	71
Route Switch Processor Card	75
Route Processor Card	76
Functional Description	76
Switch Fabric	76
Unicast Traffic	79
Multicast Traffic	80
Route Processor Functions	80
Processor-to-Processor Communication	81
Route Processor/Fabric Interconnect	81
Fabric Controller Card	82
Ethernet Line Cards	82
Modular Line Cards	83
Power System Functional Description	84
Power Modules	84
Power Module Status Indicators	85
System Power Redundancy	87
AC Power Trays	87

AC Tray Power Switch	89
AC Input Voltage Range	89
DC Output Levels	89
AC System Operation	89
Power Up	89
Power Down	90
DC Power Trays	90
DC Tray Power Switch	90
DC Power Tray Rear Panel	90
DC System Operation	91
Power Up	91
Power Down	92
Cooling System Functional Description	92
Fan Trays	97
Cisco ASR 9010 Router Fan Trays	97
Cisco ASR 9006 Router Fan Trays	98
Cisco ASR 9904 Router Fan Tray	98
Cisco ASR 9906 Router Fan Trays	99
Cisco ASR 9910 Router Fan Trays	100
Cisco ASR 9922 Router and Cisco ASR 9912 Router Fan Trays	100
Fan Tray Status Indicators	101
Fan Tray Servicing	101
Slot Fillers	102
Chassis Air Filters (Version 1 and Version 2)	102
Speed Control	108
Temperature Sensing and Monitoring	108
Servicing	109
System Shutdown	109
System Management and Configuration	109
Cisco IOS XR Software	109
System Management Interfaces	109
Command-Line Interface	109
Craft Works Interface	110
XML	110

SNMP	110
SNMP Agent	110
MIBs	110
Online Diagnostics	110
<hr/>	
CHAPTER 3	High Availability and Redundant Operation 113
Features Overview	113
High Availability Router Operations	113
Stateful Switchover	113
Fabric Switchover	114
Active/Standby Status Interpretation	114
Non-Stop Forwarding	114
Nonstop Routing	114
Graceful Restart	114
Process Restartability	115
Fault Detection and Management	115
Power Supply Redundancy	115
AC Power Redundancy	116
Cisco ASR 9010 AC Power Redundancy	116
Cisco ASR 9006 AC Power Redundancy	117
Cisco ASR 9904 AC Power Redundancy	117
Cisco ASR 9906 AC Power Redundancy	117
Cisco ASR 9910 AC Power Redundancy	117
Cisco ASR 9922 AC Power Redundancy	118
Cisco ASR 9912 AC Power Redundancy	119
DC Power Redundancy	120
Cisco ASR 9010 DC Power Redundancy	120
Cisco ASR 9006 DC Power Redundancy	121
Cisco ASR 9904 DC Power Redundancy	121
Cisco ASR 9906 DC Power Redundancy	122
Cisco ASR 9910 DC Power Redundancy	122
Cisco ASR 9912 DC Power Redundancy	122
Cisco ASR 9922 DC Power Redundancy	123
Detection and Reporting of Power Problems	124

Cooling System Redundancy 124

Cooling Failure Alarm 125

CHAPTER 4

Technical Specifications 127

Cisco ASR 9000 Series Routers Physical Descriptions 127

Cisco ASR 9000 Series Routers Environmental Specifications 129

Cisco ASR 9000 Series Routers AC Electrical Specifications 130

Cisco ASR 9000 Series Routers DC Electrical Specifications 132

AC Input and DC Input Voltage Range 134

AC Input Voltage Range 134

DC Input Voltage Range 134

Power System DC Output Levels 134

DC Output Levels for Version 1 Power System 134

DC Output Levels for Version 2 Power System 135

DC Output Levels for Version 3 Power System 135

RSP/RP Port Specifications 136

RSP, RP, FC Power Consumption Specifications 137

Fan Tray Power Consumption Specifications 139

Preface

This guide provides an overview of the basic hardware configuration and features of the Cisco ASR 9000 Series Aggregation Services Routers.

Audience

This guide is written for hardware installers and system administrators of Cisco routers.

This publication assumes that the reader has a substantial background in installing and configuring router and switch-based hardware. The reader should also be familiar with electronic circuitry and wiring practices, and have experience as an electronic or electromechanical technician.

Documentation Conventions

This document uses the following conventions:

Convention	Description
bold font	Commands and keywords and user-entered text appear in bold font .
<i>Italic font</i>	Document titles, new or emphasized terms, and arguments for which you supply values are in <i>italic font</i> .
[]	Elements in square brackets are optional.
{x y z}	Required alternative keywords are grouped in braces and separated by vertical bars.
[x y z]	Optional alternative keywords are grouped in brackets and separated by vertical bars.
string	A nonquoted set of characters. Do not use quotation marks around the string or the string will include the quotation marks.
<code>courier font</code>	Terminal sessions and information the system displays appear in <code>courier font</code> .
	Indicates a variable for which you supply values, in context where italics cannot be used.
<>	Nonprinting characters such as passwords are in angle brackets.
[]	Default responses to system prompts are in square brackets.
!, #	An exclamation point (!) or a pound sign (#) at the beginning of a line of code indicates a comment line.



Note *Means reader take note.* Notes contain helpful suggestions or references to material not covered in the manual.



Tip *Means the following information will help you solve a problem.* The tips information might not be troubleshooting or even an action, but could be useful information, similar to a Timesaver.



Caution *Means reader be careful.* In this situation, you might perform an action that could result in equipment damage or loss of data.



Warning IMPORTANT SAFETY INSTRUCTIONS

This warning symbol means danger. You are in a situation that could cause bodily injury. Before you work on any equipment, be aware of the hazards involved with electrical circuitry and be familiar with standard practices for preventing accidents. Use the statement number provided at the end of each warning to locate its translation in the translated safety warnings that accompanied this device.

SAVE THESE INSTRUCTIONS

Related Documentation

For complete planning, installation, and configuration information, see the following documents that are available on Cisco.com at the following URL: http://www.cisco.com/en/US/products/ps9853/prod_installation_guides_list.html.

Changes to This Document

This table lists the technical changes made to this document since it was first created.

Table 1: Changes to This Document

Date	Summary
September 2018	Added information for A99-SFC3, A99-SFC3-S, A99-SFC3-T, RP3, RSP5, and V3 fan tray modules.
September 2017	Added information for Cisco ASR 9906 Aggregation Services Router and SFC-T fabric card.
July 2017	Added new route processor card RSP880-LT (A9K-RSP880-LT-TR, A9K-RSP880-LT-SE).
November 2016	Added information about RP2 console port speed.
May 2016	Added information for Cisco ASR 9910 Aggregation Services Router.

Date	Summary
January 2015	Added new route processor cards RSP-440 Lite and RSP-880, FC2 fabric card, Cisco ASR 9222 V2 air filter, support for the version 3 power system, and new supported optics for Cisco IOS XR 5.3.0 .
October 2014	Add support for the Cisco ASR 9922 version 2 fan tray.
September 2013	Information added about the Cisco ASR 9904 Aggregation Services Router.
July 2013	Information added about the Cisco ASR 9912 Aggregation Services Router.
May 2013	Information added about the new 8-port 10-GE Modular Port Adapter (MPA).
September 2012	Information added about the new Cisco ASR 9922 Router, RP card, FC card, and the new 1-port 40-GE Modular Port Adapter (MPA), the new 36-Port 10-Gigabit Ethernet Line Card and the new 1-Port 100-Gigabit Ethernet Line Card .
March 2012	Information about the two types of image files, -P PIE files, and x86-based -PX PIE files added to the Functional Description chapter.
December 2011	Information added about the new RSP-440 card, 24-port 10-GE fixed line card, 2-port 100-GE fixed line card, and the modular line card supporting the 20-port GE Modular Port Adapter (MPA), 4-port 10-GE MPA, and 2-port 10-GE MPA. Information added about the new version 2 power system. The Cisco ASR 9006 Router and Cisco ASR 9010 Router now support both version 1 and version 2 power systems.
May 2010	Information added about the new 16x10-GE SFP+ line card and additional versions of existing cards.
December 2009	Information added about new 8x10GE 80-Gbps line rate card and 2x10GE + 20x1GE combination line card.
March 2009	Initial release of this document.

Obtaining Documentation and Submitting a Service Request

For information on obtaining documentation, using the Cisco Bug Search Tool (BST), submitting a service request, and gathering additional information, see *What's New in Cisco Product Documentation*, at: <http://www.cisco.com/c/en/us/td/docs/general/whatsnew/whatsnew.html>.

Subscribe to *What's New in Cisco Product Documentation*, which lists all new and revised Cisco technical documentation as an RSS feed and delivers content directly to your desktop using a reader application. The RSS feeds are a free service.



CHAPTER 1

Overview and Physical Description

This chapter provides an overview of the Cisco ASR 9000 Series Aggregation Services Routers and description of the system components.

- [Chassis Physical Overview, on page 1](#)
- [Rack-Mounting Specifications, on page 8](#)
- [Route Switch Processor and Route Processor Cards, on page 28](#)
- [Fabric Controller Card, on page 55](#)
- [Ethernet Line Cards , on page 58](#)
- [Power System , on page 59](#)
- [Cooling System , on page 68](#)
- [Management and Configuration, on page 70](#)

Chassis Physical Overview

The Cisco ASR 9000 Series Routers are next-generation edge access routers optimized for service provider applications, designed to fulfill various roles in:

- Layer 2 and Layer 3 Ethernet aggregation
- Subscriber-aware broadband aggregation

The Cisco ASR 9000 Series Routers meet carrier-class requirements for redundancy, availability, packaging, power, and other requirements traditional to the service provider.

The Cisco ASR 9000 Series consists of the following routers:

- Cisco ASR 9001 Router
- Cisco ASR 9001-S Router
- Cisco ASR 9010 Router
- Cisco ASR 9006 Router
- Cisco ASR 9904 Router
- Cisco ASR 9906 Router
- Cisco ASR 9910 Router

- Cisco ASR 9922 Router
- Cisco ASR 9912 Router

This chapter briefly describes the chassis configuration and components of the Cisco ASR 9000 Series Routers. For information on the Cisco ASR 9001 and Cisco ASR 9001-S Routers, see the [Cisco ASR 9001 and Cisco ASR 9001-S Routers Hardware Installation Guide](#).

Cisco ASR 9010 Router

The Cisco ASR 9010 Router chassis is centered around a redundant pair of RSP cards, along with eight line cards. The 10-slot chassis size fits in Telco, EIA, and ETSI racks and cabinets.

The chassis has two power trays. The version 1 power system has AC or DC power modules (six total) in each tray. The version 2 and version 3 power system has four AC or DC power modules (eight total) in each tray .

Figure 1: Cisco ASR 9010 Router Chassis Components—Version 1 Power Trays

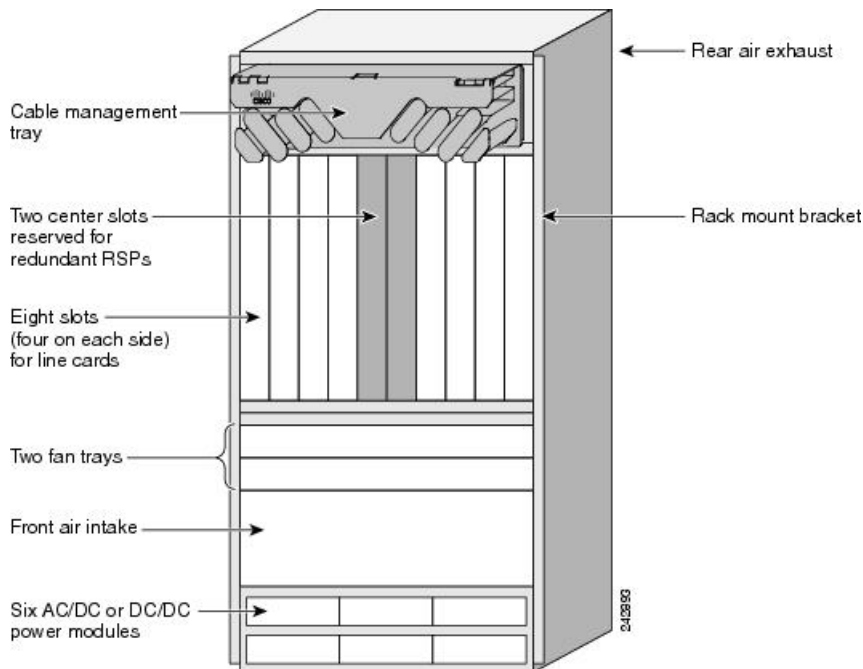
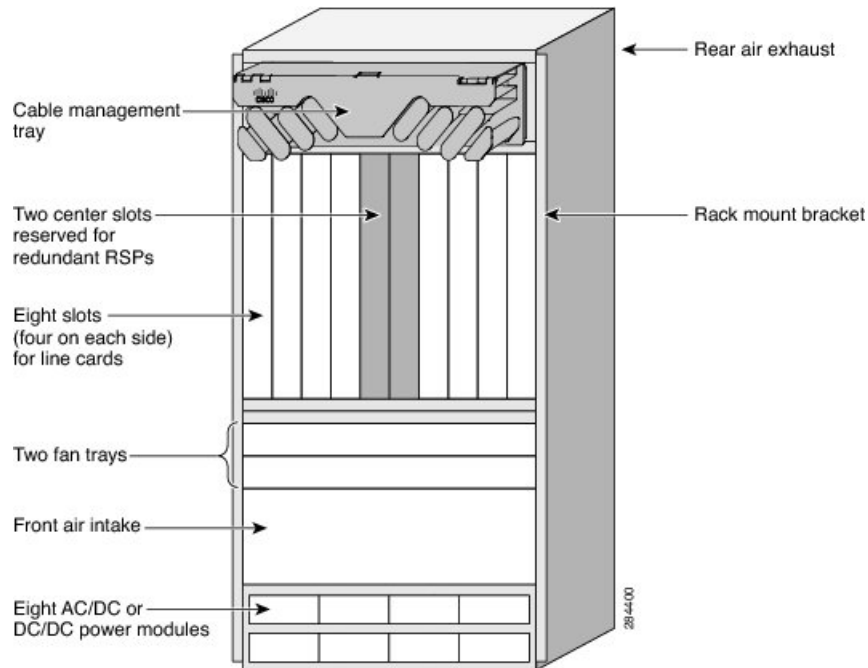


Figure 2: Cisco ASR 9010 Router Chassis Components—Version 2 and 3 Power Trays

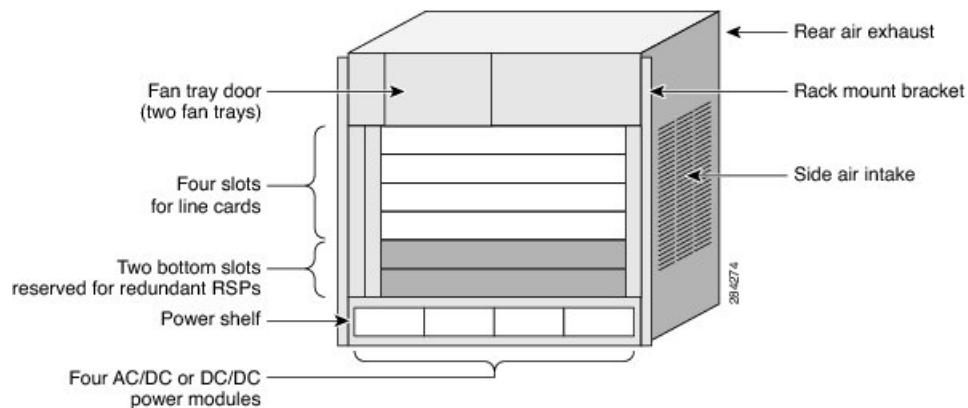


Cisco ASR 9006 Router

The Cisco ASR 9006 Router chassis is centered around a redundant pair of RSP cards, along with four line cards. The 6-slot chassis size fits in Telco, EIA, and ETSI racks and cabinets.

The chassis has a single power tray for AC or DC power modules. The version 1 power system has three power modules in the single power tray. The version 2 power system has four power modules in the single power tray.

Figure 3: Cisco ASR 9006 Router Chassis Components—Version 2 Power Tray Shown

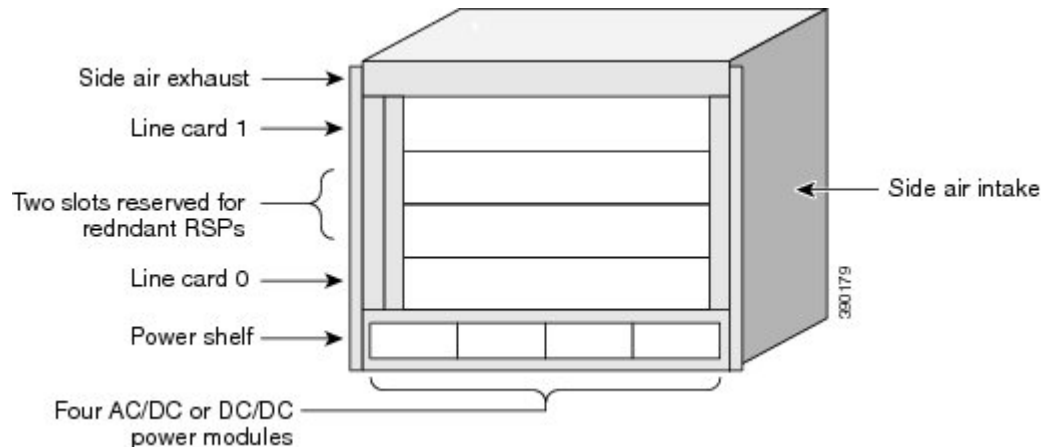


Note The ASR 9006 chassis does not support version 3 power modules.

Cisco ASR 9904 Router

The Cisco ASR 9904 Router chassis is centered around a redundant pair of RSP cards, along with two line cards. The 4-slot chassis size fits in Telco, EIA, and ETSI racks and cabinets. The chassis has a single version 2 power tray for AC or DC power modules.

Figure 4: Cisco ASR 9904 Router Chassis Components—Version 2 Power System



Cisco ASR 9906 Router

The Cisco ASR 9906 Router chassis is centered on a redundant pair of Route Switch Processor (RSP) cards, four line cards, and five Fabric Cards (FC). The 6-slot chassis size fits in Telco, EIA, and ETSI racks and cabinets. The chassis has version 3 power tray. The version 3 power system has three AC or four DC power modules in each tray. The ASR 9906 Router is supported with the RSP4-S (A99-RSP-SE, A99-RSP-TR) and the SFC-T fabric card.

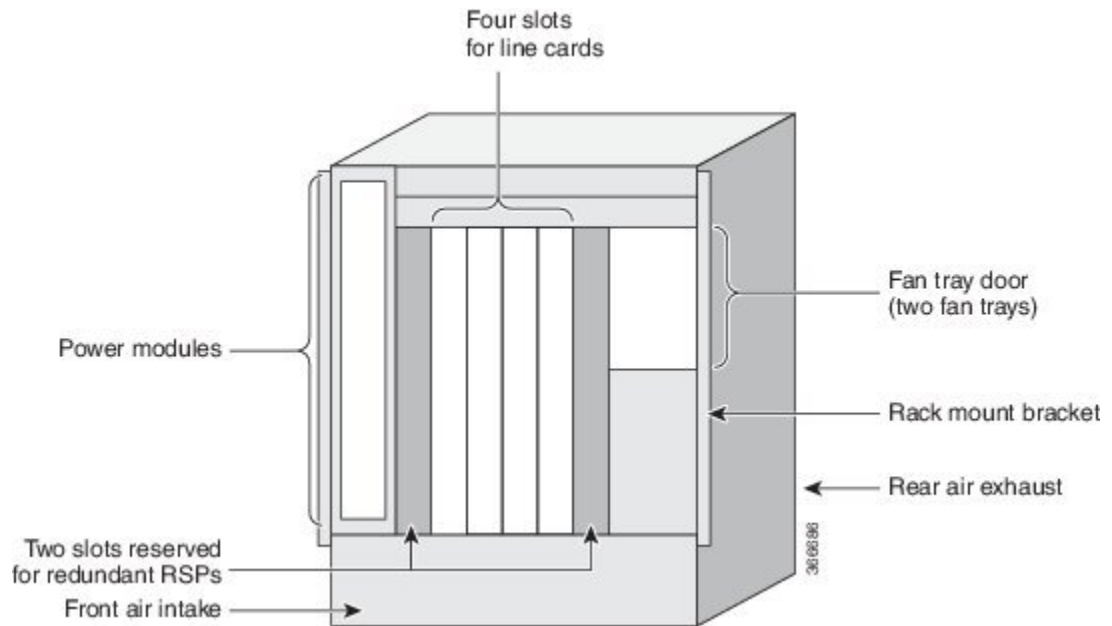


Note The RSP4-S shipped with IOS XR 6.3.1 supports IOS XR 32-bit and 64-bit on the Cisco ASR 9906 Router. If you are installing a previously shipped RSP4-S (for example, from an Cisco ASR 9910 Router) in a Cisco ASR 9906 Router, you need to perform a Field Programmable Device (FPD) upgrade (available in IOS XR 6.3.1) in order to support IOS XR 64-bit. For more information, refer to field notice FN-70022.



Note The Cisco ASR 9906 supports A9K-VSM-500 and Tomahawk-based line cards; it does not support SIP-700, A9K-ISM-100, Trident-based, or Typhoon-based line cards. Refer to [ASR 9000 Series Line Card Types](#) for information on line card types.

Figure 5: Cisco ASR 9906 Router Chassis Components—Version 3 Power System



Cisco ASR 9910 Router

The Cisco ASR 9910 chassis is centered around a redundant pair of RSP cards, along with eight line cards and five fabric cards (FCs). The 10-slot chassis size fits in Telco, EIA, and ETSI racks and cabinets.

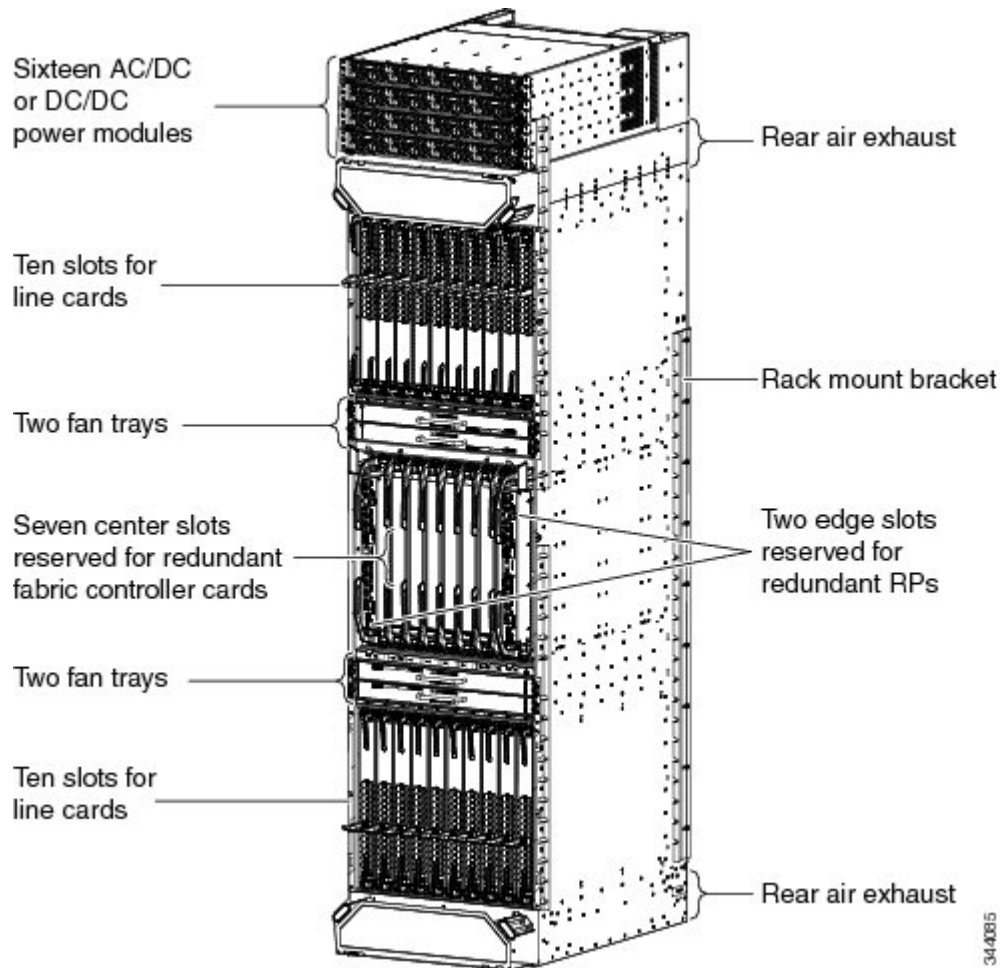
The chassis has version 3 power tray. The version 3 power system has three AC or four DC power modules in each tray.

Cisco ASR 9922 Router

The Cisco ASR 9922 Router chassis is centered around a redundant pair of RP cards, seven redundant FC cards, and twenty line cards. The 22-slot chassis size fits in Telco, EIA, and ETSI racks and cabinets. The chassis has two backplanes connected via up to seven fabric cards and two RP cards. The upper backplane connects to its one backplane identification (BPID) card, ten line cards, two fan trays, and four power trays. The lower backplane connects to its BPID card, ten line cards, and two fan trays.

The chassis has four power trays. The version 2 power system has four AC or DC power modules in each power tray. The version 3 power system has three AC power modules or four DC power modules in each power tray.

Figure 6: Cisco ASR 9922 Router Chassis Components—Version 2 Power Tray

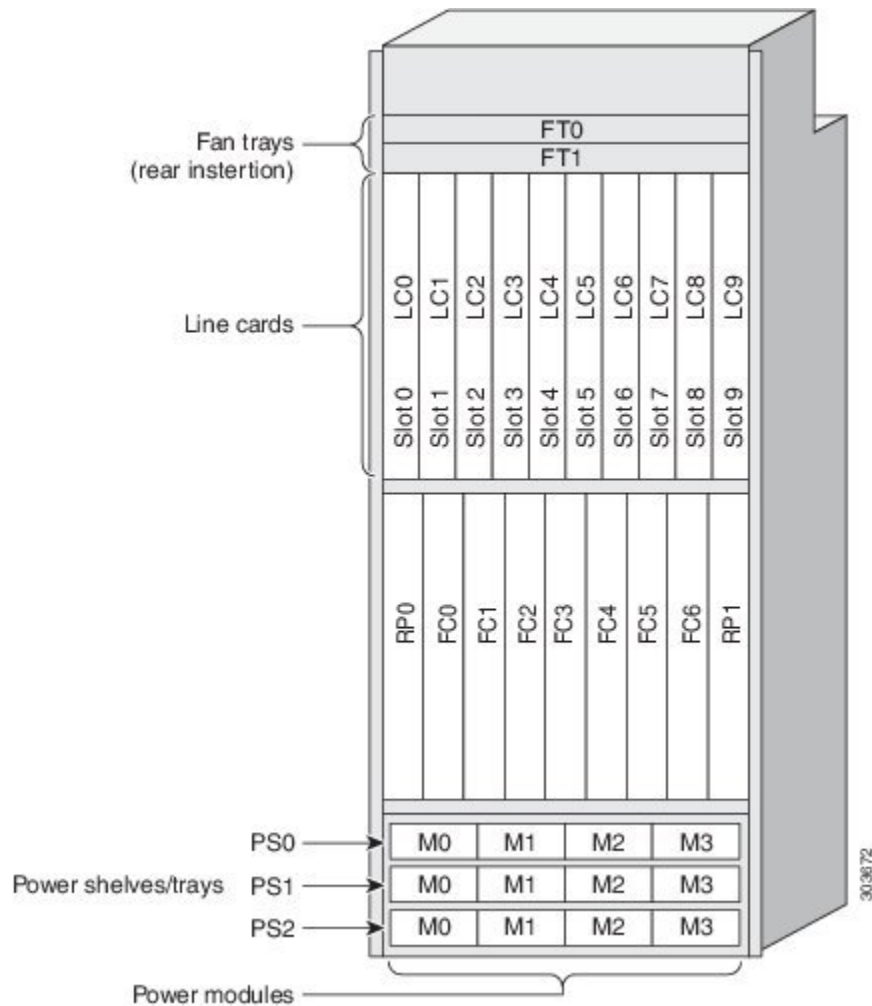


Cisco ASR 9912 Router

The Cisco ASR 9912 Router chassis is centered around a redundant pair of RP cards, seven redundant FC cards, and ten line cards. The chassis fits in Telco, EIA, and ETSI racks and cabinets.

The chassis has three power trays. The version 2 power system has four AC or DC power modules in each power tray. The version 3 AC power system has three AC power modules in each power tray. The version 3 DC power system has four DC power modules in each power tray.

Figure 7: Cisco ASR 9912 Router Chassis Components—Version 2 Power Tray



Field Replaceable Units

In the Cisco ASR 9010 Router, Cisco ASR 9006 Router, and Cisco ASR 9904 Router, the following components are field replaceable units (FRUs):

- All line cards
- RSP cards
- Power modules
- Fan trays
- Air filters
- Line card and RSP blank fillers
- Compact flash disk
- Gigabit Ethernet small form-factor pluggable (SFP) transceiver modules

- 10-Gigabit Ethernet small form-factor pluggable (SFP+) transceiver modules
- 10-Gigabit Ethernet small form-factor pluggable (XFP) transceiver modules
- Optional card cage doors (Cisco ASR 9010 Router only)



Note The backplane and BPID are not FRUs.

In the Cisco ASR 9922 Router, Cisco ASR 9906 Router, Cisco ASR 9910 Router, and the Cisco ASR 9912 Router, the following components are FRUs:

- All line cards
- RP cards (only for Cisco ASR 9922 and Cisco ASR 9912)
- RSP cards (only for Cisco ASR 9906 Router and Cisco ASR 9910 Router)
- FC cards
- Power modules
- Fan trays and covers
- Air filters and foam media
- Line card and RP/RSP blank fillers
- Gigabit Ethernet small form-factor pluggable (SFP) transceiver modules
- 10-Gigabit Ethernet small form-factor pluggable (SFP+) transceiver modules
- 100-Gigabit Ethernet small form-factor pluggable (CFP) transceiver modules
- Optional card cage doors (only for Cisco ASR 9922 and Cisco ASR 9912)



Note The backplanes, midplane, PEM (only for Cisco ASR 9910 Router) and BPID cards are not FRUs.

Rack-Mounting Specifications

The following table lists the rack-mounting specifications for the Cisco ASR 9000 Series Routers.

Table 2: Cisco ASR 9000 Series Routers Rack Mounting Specifications

Chassis Type	Rack Mounting Specifications
Cisco ASR 9010 Router	<p>Chassis height is 36.75 inches (93.35 cm) or 21 RU (rack units), which includes a rack/tray mounting option. Two chassis fit into a commonly used 42 RU rack, and therefore will fit into an ETSI 45 RU rack with a height of 78.74 inches (200.00 cm).</p> <p>Telco racks: Rail-to-rail dimension is 17.50 inches (44.54 cm)</p> <p>EIA racks: 19 inches (48.26 cm) wide</p> <p>Adaptable to 23 inches (58.42 cm) to fit into ETSI racks 23.62 inches (60.00 cm) wide</p>
Cisco ASR 9006 Router	<p>Chassis height is 17.50 inches (44.45 cm) or 10 RU (rack units), which includes a rack/tray mounting option. Four chassis fit into a commonly used 42 RU rack, and therefore will fit into an ETSI 45 RU rack with a height of 78.74 inches (200.00 cm).</p> <p>Telco racks: Rail-to-rail dimension is 17.75 inches (45.09 cm)</p> <p>EIA racks 19 inches (48.26 cm) wide</p> <p>Adaptable to 23 inches (58.42 cm) to fit into ETSI racks 23.62 inches (60.00 cm) wide</p>
Cisco ASR 9904 Router	<p>Chassis height is 10.38 inches (26.36 cm) or 6 RU (rack units), which includes a rack/tray mounting option. Seven chassis fit into a commonly used 42 RU rack, and therefore will fit into an ETSI 45 RU rack with a height of 78.74 inches (200.00 cm).</p> <p>Telco racks: Rail-to-rail dimension is 17.75 inches (45.09 cm)</p> <p>EIA racks: 19 inches (48.26 cm) wide</p> <p>Adaptable to 23 inches (58.42 cm) to fit into ETSI racks 23.62 inches (60.00 cm) wide</p>
Cisco ASR 9906 Router	<p>Chassis height is 24.39 inches (61.95 cm) or 14 RU (rack units), which includes a rack/tray mounting option. Three chassis fit into a commonly used 42 RU rack, and therefore will fit into an ETSI 45 RU rack with a height of 78.74 inches (200.00 cm).</p> <p>Telco racks: Rail-to-rail dimension is 17.60 inches (44.70 cm)</p> <p>EIA racks: 19 inches (48.26 cm) wide</p> <p>Adaptable to 23 inches (58.42 cm) to fit into ETSI racks 23.62 inches (60.00 cm) wide</p>

Chassis Type	Rack Mounting Specifications
Cisco ASR 9910 Router	<p>Chassis height is 36.70 inches (93.218 cm) or 21 RU (rack units), which includes a rack/tray mounting option. Two chassis fit into a commonly used 42 RU rack, and therefore will fit into an ETSI 45 RU rack with a height of 78.74 inches (200.00 cm).</p> <p>Telco racks: Rail-to-rail dimension is 17.50 inches (44.54 cm)</p> <p>EIA racks: 19 inches (48.26 cm) wide</p> <p>Adaptable to 23 inches (58.42 cm) to fit into ETSI racks 23.62 inches (60.00 cm) wide</p>
Cisco ASR 9912 Router	<p>Chassis height is 52.50 inches (133.35 cm) or 30 RU (rack units). The rail mounting option height is 1.00 inch. The Cisco ASR 9912 Router chassis will fit into an ETSI 45 RU rack with a height of 78.74 inches (200.00 cm).</p> <p>Telco racks: Rail-to-rail dimension is 17.75 inches (45.09 cm)</p> <p>EIA racks: 19 inches (48.26 cm) wide</p> <p>Adaptable to 23 inches (58.42 cm) to fit into ETSI racks 23.62 inches (60.00 cm) wide</p>
Cisco ASR 9922 Router	<p>Chassis height is 77.00 inches (195.58 cm) or 44 RU (rack units). The rail mounting option height is 1.00 inch. The Cisco ASR 9922 Router chassis will fit into an ETSI 45 RU rack with a height of 78.74 inches (200.00 cm).</p> <p>Telco racks: Rail-to-rail dimension is 17.75 inches (45.09 cm)</p> <p>EIA racks: 19 inches (48.26 cm) wide</p> <p>Adaptable to 23 inches (58.42 cm) to fit into ETSI racks 23.62 inches (60.00 cm) wide</p>

The chassis depth for all Cisco ASR 9000 Series Routers fits into a 31.50 inch (80.00 cm) deep EIA rack or an equivalent 80.00 cm deep rack. This space includes cable management space front and rear. The chassis has fixed rack mount rails that are set back 5.00 inches (12.7 cm), including front cable management space.



Note Racks and cabinets require adjustable front rails if the rack/cabinet doors must be able to close with the chassis installed.

Chassis Top-Down View Dimensions

- [Figure 8: Cisco ASR 9010 Router Chassis Footprint Dimensions—Top Down View](#), on page 11 shows the top-down view dimensions of the Cisco ASR 9010 Router.
- [Figure 9: Cisco ASR 9006 Router Chassis Footprint Dimensions—Top Down View](#), on page 12 shows the top-down view dimensions of the Cisco ASR 9006 Router.
- [Figure 10: Cisco ASR 9904 Router Chassis Footprint Dimensions—Top Down View](#), on page 13 shows the top-down view dimensions of the Cisco ASR 9904 Router.

- [Figure 11: Cisco ASR 9906 Router Chassis Footprint Dimensions—Top Down View](#) shows the top-down view dimensions of the Cisco ASR 9906 Router.
- [Figure 12: Cisco ASR 9910 Router Chassis Footprint Dimensions—Top Down and Side View](#), on page 15 shows the top-down view dimensions of the Cisco ASR 9910 Router.
- [Figure 13: Cisco ASR 9922 Router Chassis Footprint Dimensions—Top Down View](#), on page 16 shows the top-down view dimensions of the Cisco ASR 9922 Router.
- [Figure 14: Cisco ASR 9912 Router Chassis Footprint Dimensions—Top Down View](#), on page 17 shows the top-down view dimensions of the Cisco ASR 9912 Router.

Figure 8: Cisco ASR 9010 Router Chassis Footprint Dimensions—Top Down View

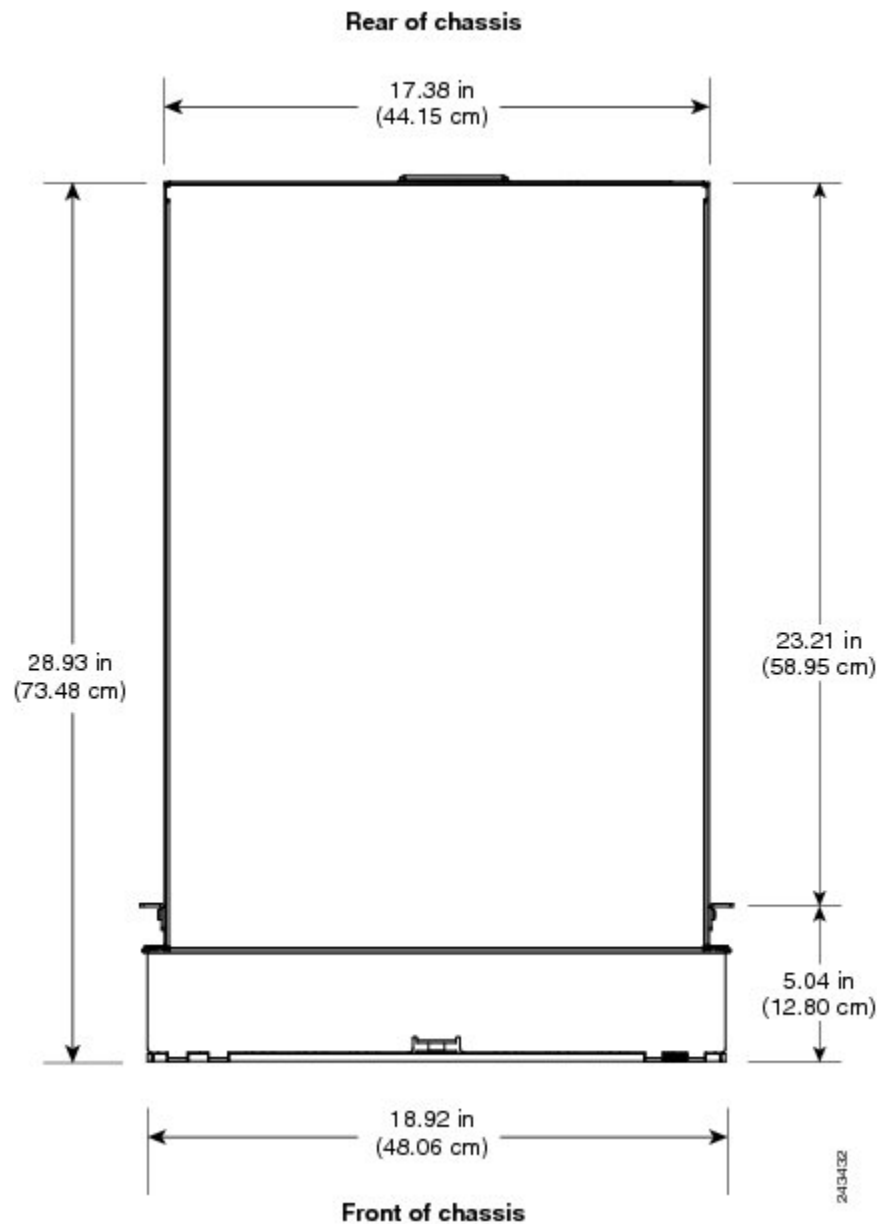


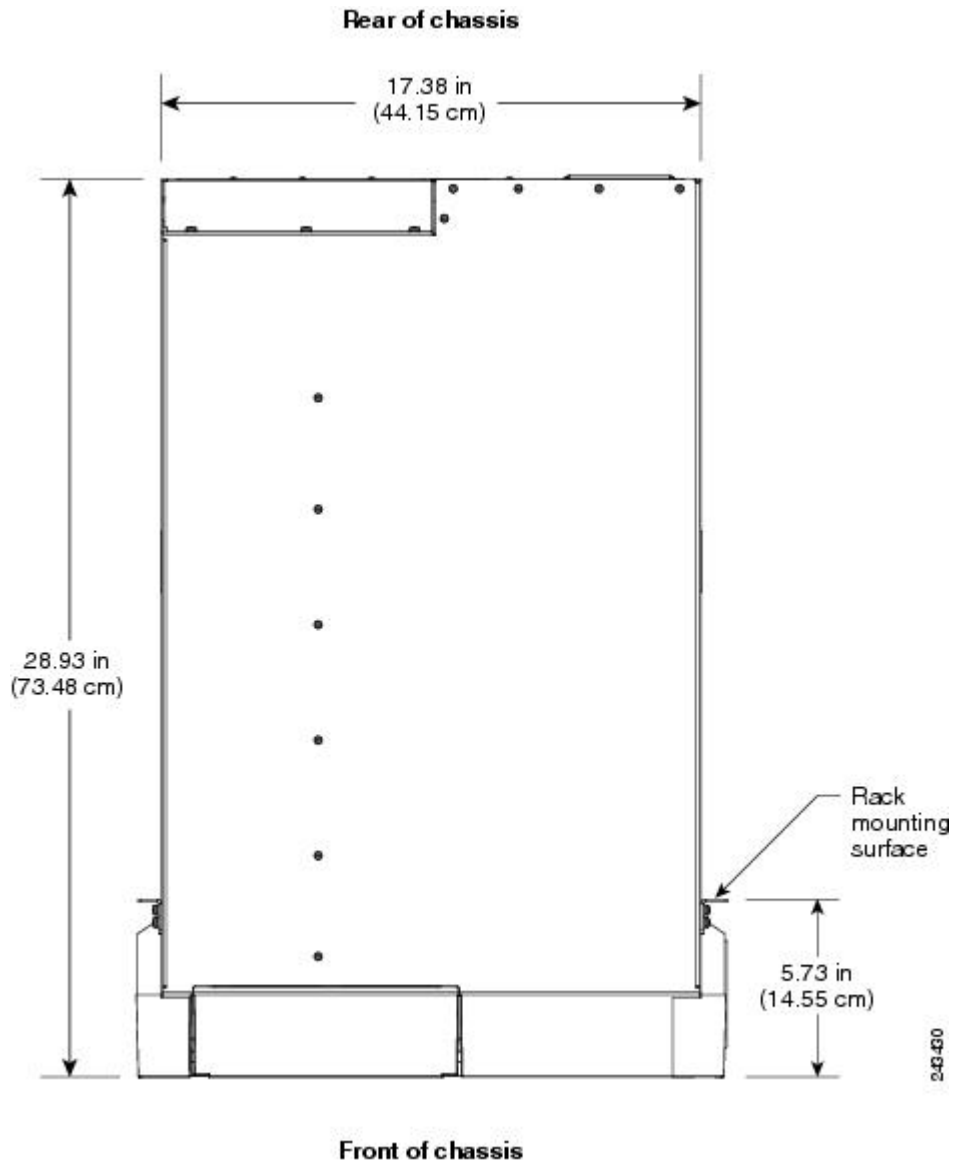
Figure 9: Cisco ASR 9006 Router Chassis Footprint Dimensions—Top Down View

Figure 10: Cisco ASR 9904 Router Chassis Footprint Dimensions—Top Down View

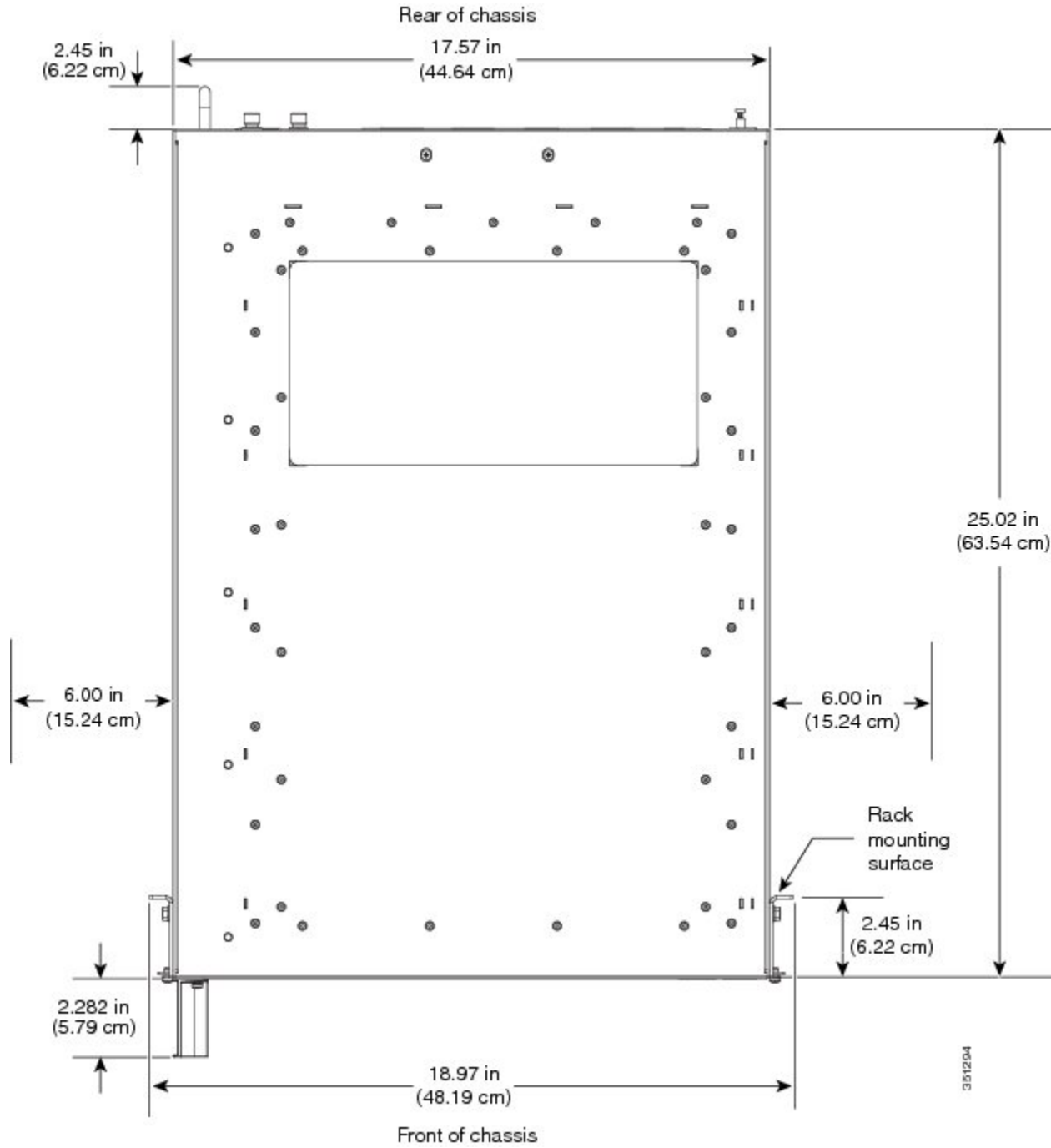


Figure 11: Cisco ASR 9906 Router Chassis Footprint Dimensions—Top Down View

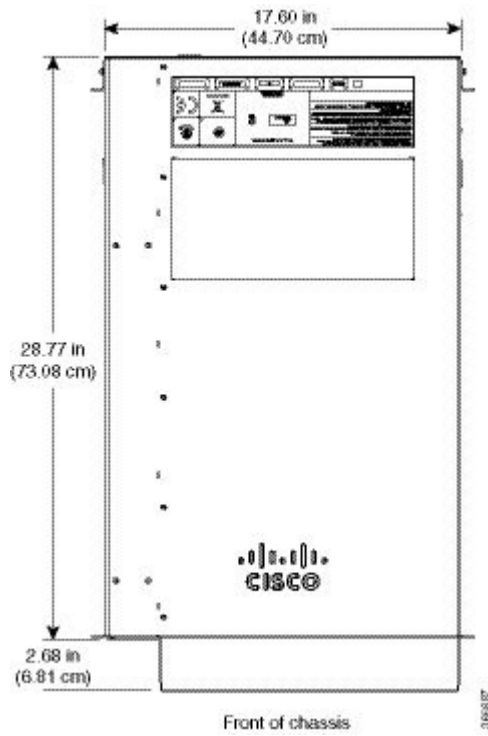


Figure 12: Cisco ASR 9910 Router Chassis Footprint Dimensions—Top Down and Side View

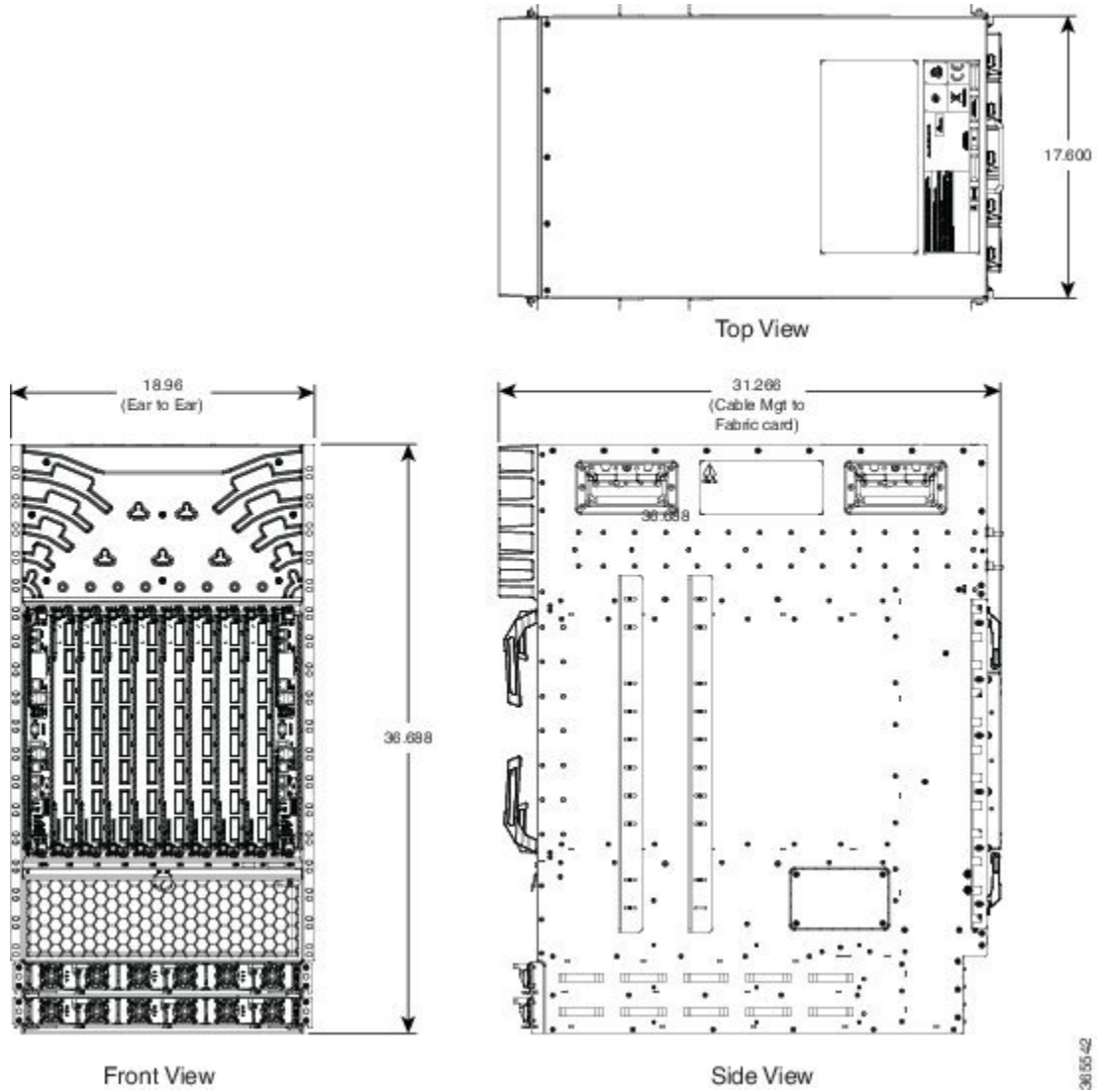


Figure 13: Cisco ASR 9922 Router Chassis Footprint Dimensions—Top Down View

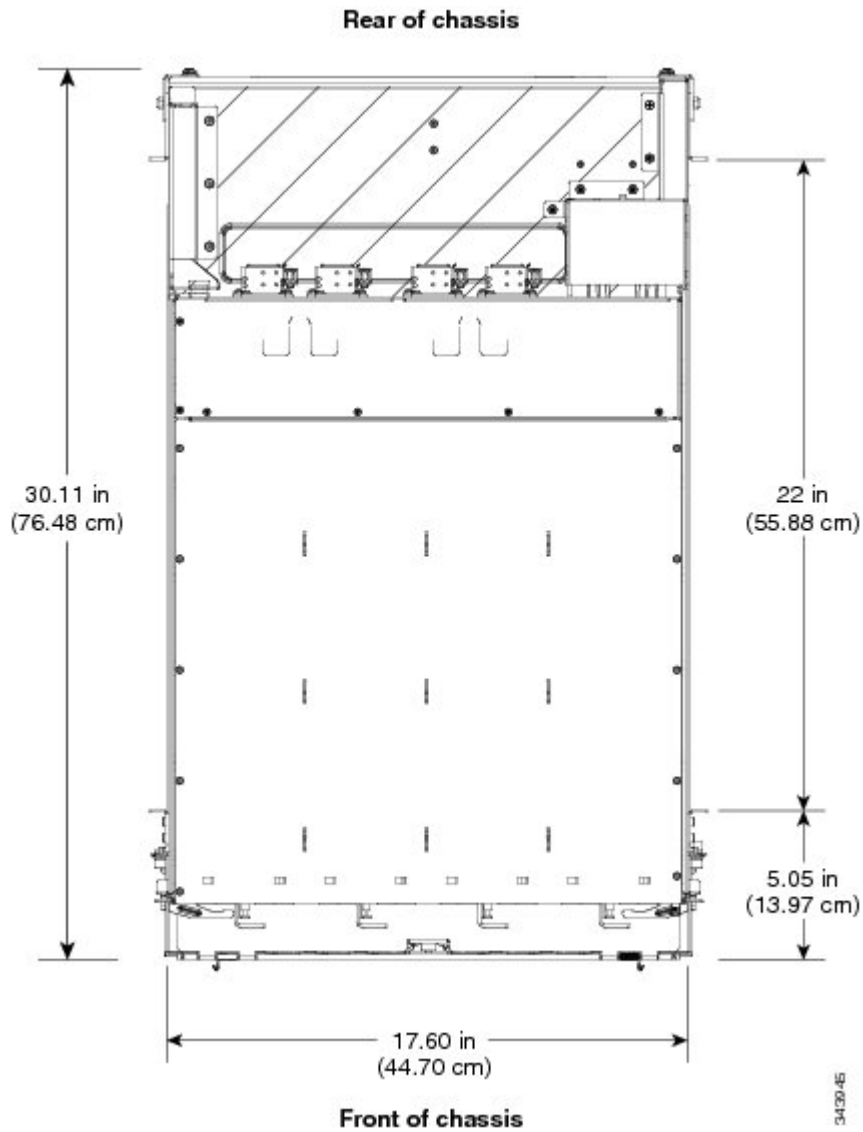
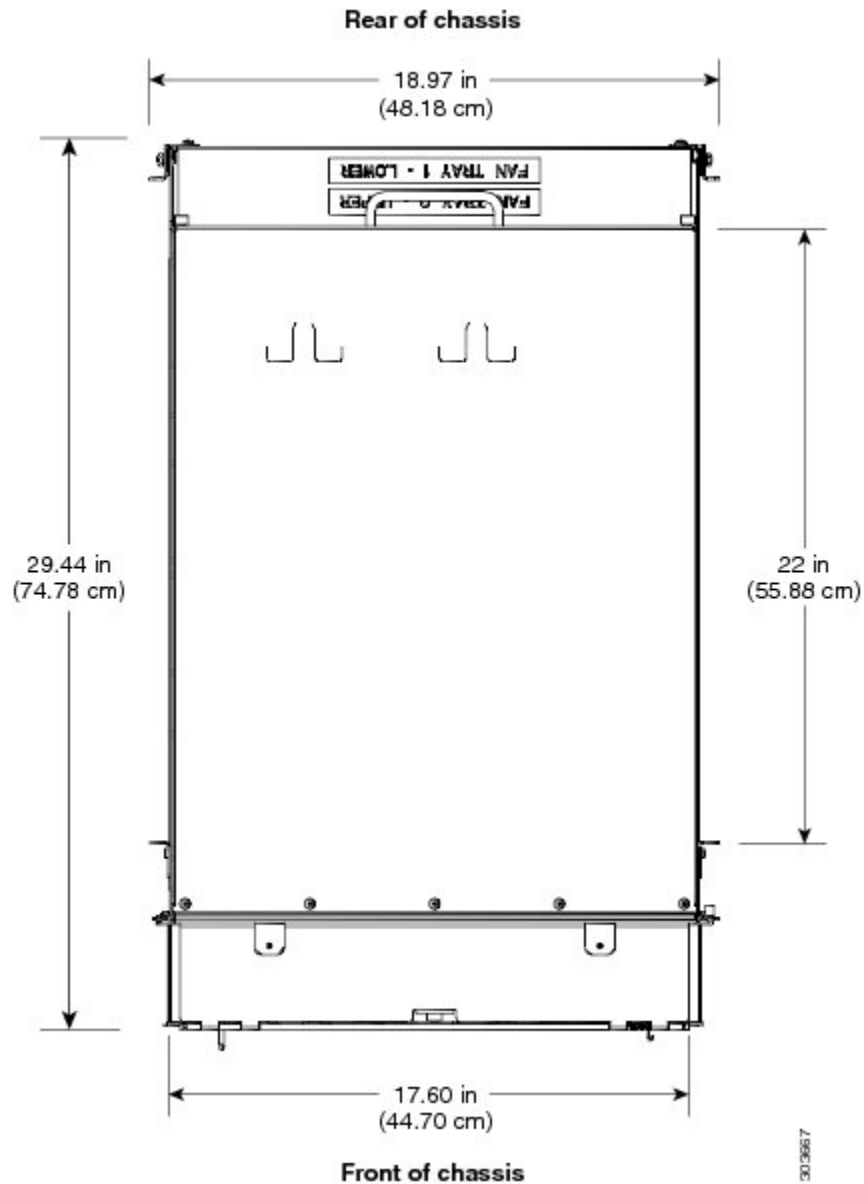


Figure 14: Cisco ASR 9912 Router Chassis Footprint Dimensions—Top Down View



Chassis Slots

- Cisco ASR 9010 Router: All line cards and RSP cards are front-facing and mounted vertically, with ejector levers and captive screws at the top and bottom of each card.
- Cisco ASR 9006 Router and Cisco ASR 9904 Router: All chassis line cards and RSP cards are front-facing and mounted horizontally, with ejector levers and captive screws at the left and right ends of each card.
- Cisco ASR 9906 Router: All line cards and RSP cards are front-facing and mounted vertically, with ejector levers and captive screws at the top and bottom of each card. All FCs are rear-facing and mounted vertically, with ejector levers and captive screws at the top and bottom of each card.

- Cisco ASR 9910 Router: All line cards and RSP cards are front-facing and mounted vertically, with ejector levers and captive screws at the top and bottom of each card.
- Cisco ASR 9922 Router: All RP, FCs, and LCs are front-facing and mounted vertically, with ejector levers and captive screws at the top and bottom of each card.
- Cisco ASR 9912 Router: All RP, FCs, and LCs are front-facing and mounted vertically, with ejector levers and captive screws at the top and bottom of each card.

The chassis components include:

- Two RSP cards in the Cisco ASR 9010 Router, Cisco ASR 9006 Router, Cisco ASR 9904 Router, Cisco ASR 9906 Router, and Cisco ASR 9910 Router.
- Two RP and seven FC cards in the Cisco ASR 9922 Router and Cisco ASR 9912 Router
- Five FC cards in the Cisco ASR 9906 Router and Cisco ASR 9910 Router.
- Ethernet line cards
 - Cisco ASR 9010 Router—Up to eight
 - Cisco ASR 9006 Router—Up to four
 - Cisco ASR 9904 Router—Up to two
 - Cisco ASR 9906 Router—Up to four
 - Cisco ASR 9910 Router—Up to eight
 - Cisco ASR 9922 Router—Up to twenty
 - Cisco ASR 9912 Router—Up to ten
- Backplane(s)
 - Cisco ASR 9010 Router—One
 - Cisco ASR 9006 Router—One
 - Cisco ASR 9904 Router—One
 - Cisco ASR 9922 Router—Two
 - Cisco ASR 9912 Router—One
- Midplane(s)
 - Cisco ASR 9906 Router—One
 - Cisco ASR 9910 Router—One
- BPID card(s)
 - Cisco ASR 9010 Router—One
 - Cisco ASR 9006 Router—One
 - Cisco ASR 9904 Router—One
 - Cisco ASR 9906 Router—One

- Cisco ASR 9910 Router—One
- Cisco ASR 9922 Router—Two
- Cisco ASR 9912 Router—One

- Fan tray controllers
 - Cisco ASR 9010 Router—Two
 - Cisco ASR 9006 Router—Two
 - Cisco ASR 9904 Router—One
 - Cisco ASR 9906 Router—Two
 - Cisco ASR 9910 Router—Two
 - Cisco ASR 9922 Router—Four
 - Cisco ASR 9912 Router—Two

- Power trays
 - Cisco ASR 9010 Router—Two AC power trays in AC-powered systems or two DC power trays in DC-powered systems
 - Cisco ASR 9006 Router—One AC power tray in AC-powered systems or one DC power tray in DC-powered systems
 - Cisco ASR 9904 Router—One AC power tray in AC-powered systems or one DC power tray in DC-powered systems
 - Cisco ASR 9906 Router—One AC power tray in AC-powered systems or one DC power tray in DC-powered systems
 - Cisco ASR 9910 Router—Two AC power trays in AC-powered systems or two DC power trays in DC-powered systems
 - Cisco ASR 9922 Router—Four AC power trays in AC-powered systems or four DC power trays in DC-powered systems
 - Cisco ASR 9912 Router—Three AC power trays in AC-powered systems or three DC power trays in DC-powered systems

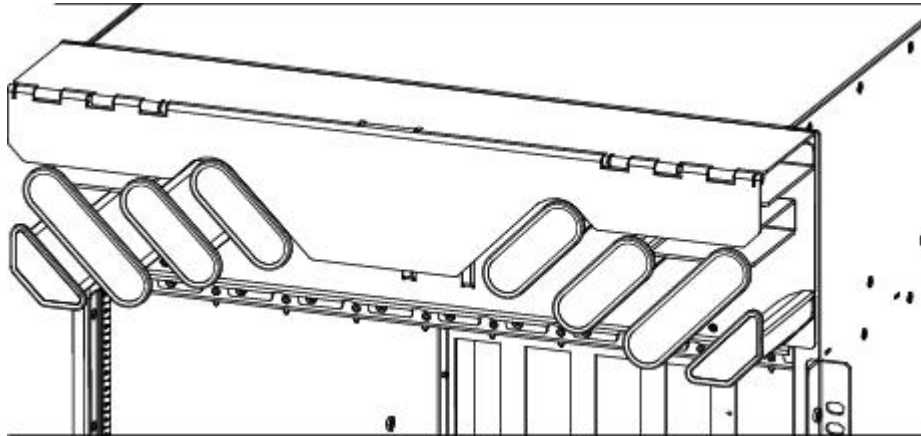


Note The line card slots are dedicated to only line cards; RSP/RP/FC cards cannot occupy these slots. The RSP/RP/FC slots are dedicated to only RSP/RP/FC cards; line cards cannot occupy these slots. A keying mechanism keeps line cards from entering RSP/RP/FC slots and RSP/RP/FC cards from entering line card slots; the keying mechanism pins engage before the card alignment pins engage.

Fiber and Interface Cable Management

The following image shows how card interface cables are managed at the front of the Cisco ASR 9010 Router chassis using a cable management tray.

Figure 15: Cable Management Tray



The Cisco ASR 9922 Router and Cisco ASR 9912 Router have a cable management tray located above the card cage and a cable management tray below the bottom card cage that do not interfere with the insertion or removal of cards. A hinged cover at the top of the tray can be raised for ease of access for routing cables.

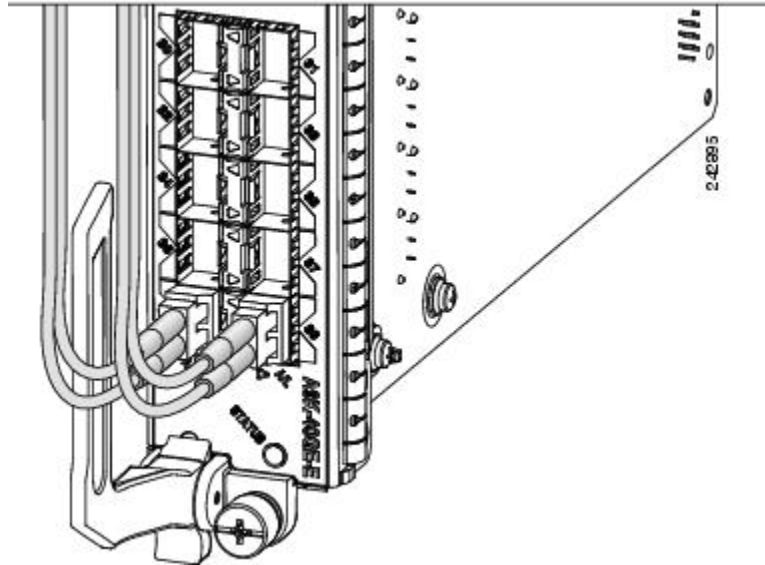
Line cards and RSP/RP cards share the same cable management tray. Cables to a card must be disconnected before its removal (this does not affect adjacent cards). Removal of a line card or RSP/RP card does not require removal or adjustment of cables other than those associated with the card itself.

A cable management bend radius of 1.5 inches (3.81 cm) is accommodated. Line card slots at the extreme ends of the cable management trays use space outside of the chassis width to accommodate the 1.5-inch (3.81-cm) radii due to limited space per slot.

Space for the fiber bend radii and strain relief is 3.75 inches (9.53 cm) in front of the faceplate.

The following figure shows how the fiber and cables are routed upward away from slot number labels. Therefore slot number labels, located at the lower part of the card cage, are not obscured by the cables.

Figure 16: Fiber/Cable Routing in the Cisco ASR 9010 Router

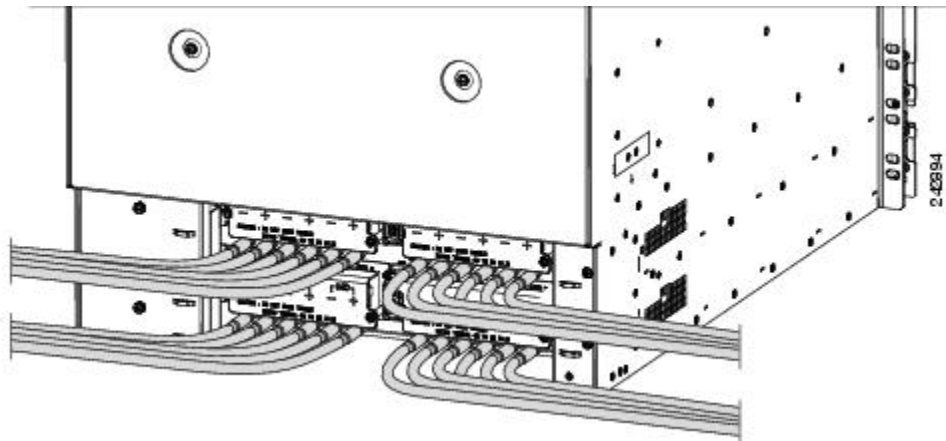


Routing of DC Power Tray Source Cables

Power cables are located in the rear. The A and B source feeds to the DC power supply modules are separated so the cables route to opposite sides of the chassis. A cable tie down point is provided.

The following figure shows the DC power cable routing on the power trays.

Figure 17: Routing of DC Power Tray Source Cables



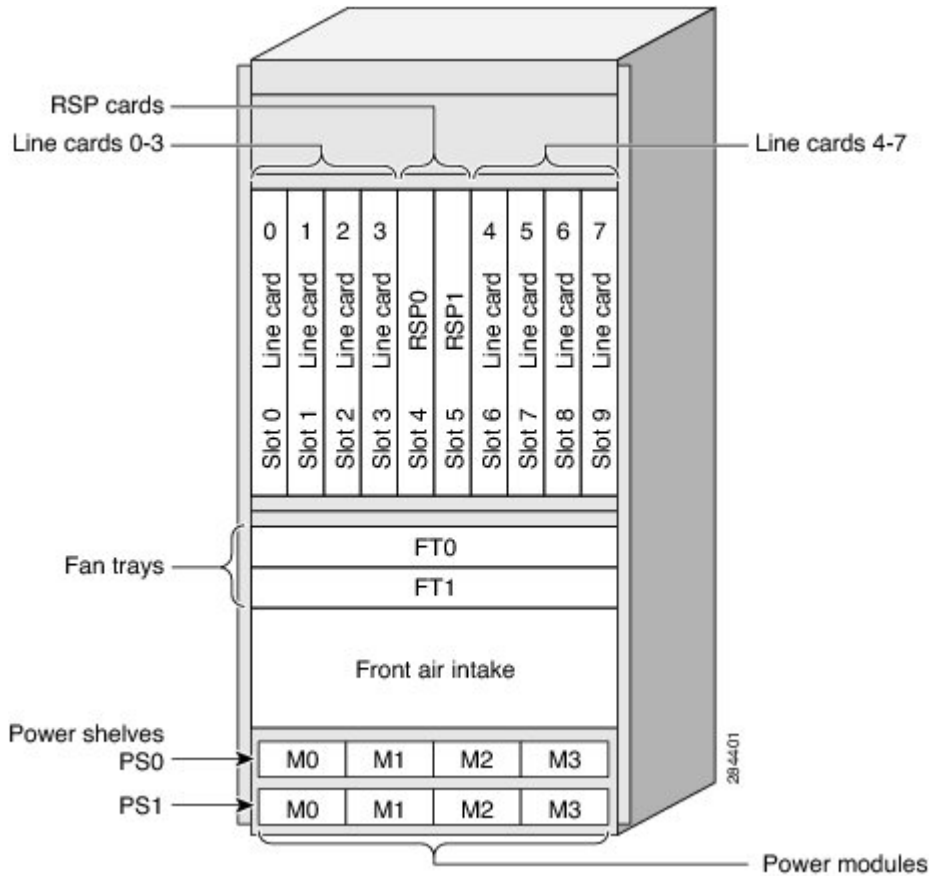
Slot ID Numbering

All card slots are clearly numbered. Labels identifying slots are visible from the front of the chassis and are clearly numbered below each slot. As mentioned previously, fiber and cables are routed upward and do not obscure the slot ID labels.

Cisco ASR 9010 Router

The following figure shows slot ID numbering for the Cisco ASR 9010 Router with the DC power system. The numbering for the AC power system is the same but each power tray only holds three power modules.

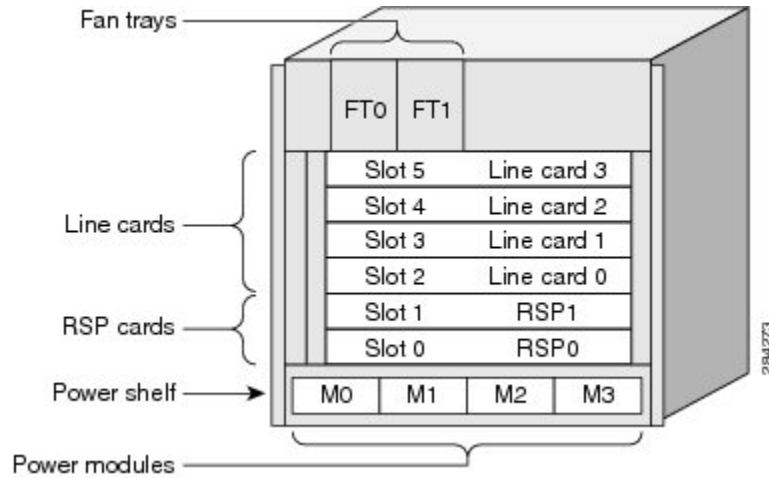
Figure 18: Cisco ASR 9010 Router Slot ID Numbering



Cisco ASR 9006 Router

The following figure shows the slot ID numbering for the Cisco ASR 9006 Router with the DC power system. The numbering for the AC power system is the same but each tray only holds three power modules.

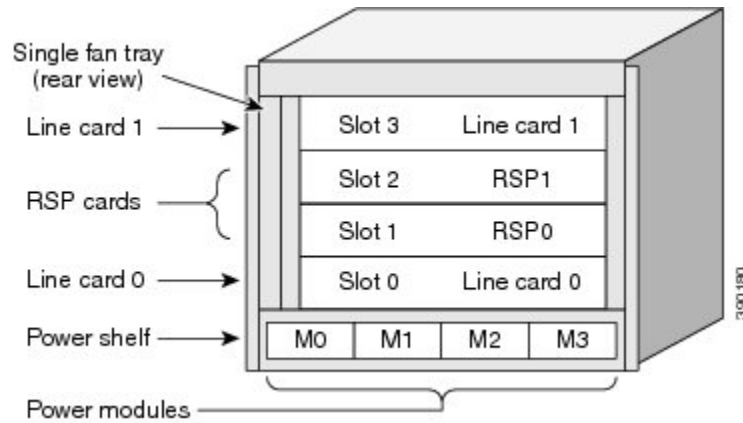
Figure 19: Cisco ASR 9906 Router Slot ID Numbering



Cisco ASR 9904 Router

The following figure shows the slot ID numbering for the Cisco ASR 9904 Router.

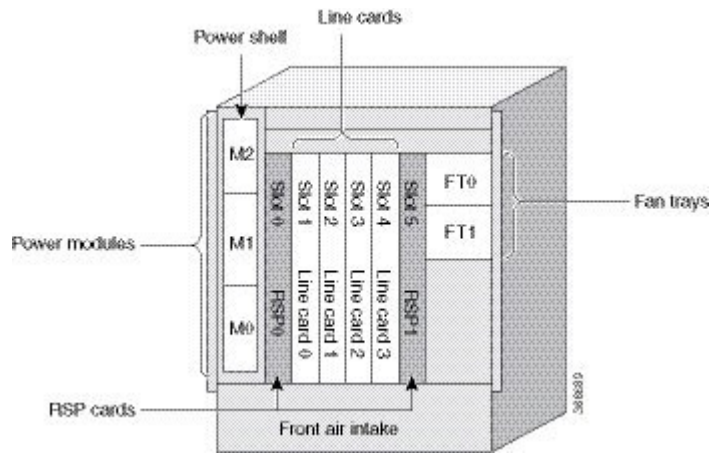
Figure 20: Cisco ASR 9904 Router Slot ID Numbering



Cisco ASR 9906 Router

The following figure shows the slot ID numbering for the Cisco ASR 9906 Router.

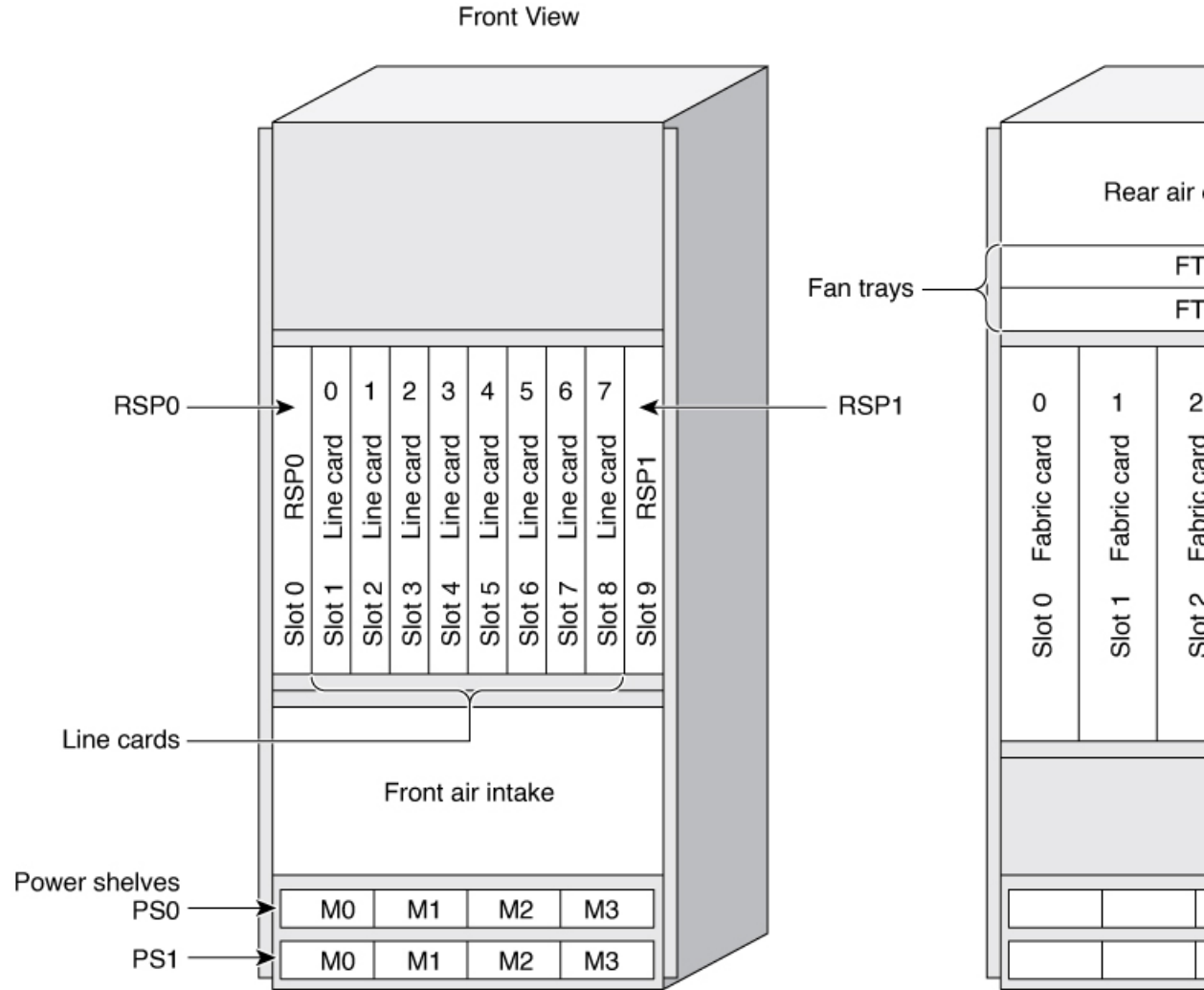
Figure 21: Cisco ASR 9906 Router Slot ID Numbering



Cisco ASR 9910 Router

The following figure shows the slot ID numbering for the Cisco ASR 9910 Router

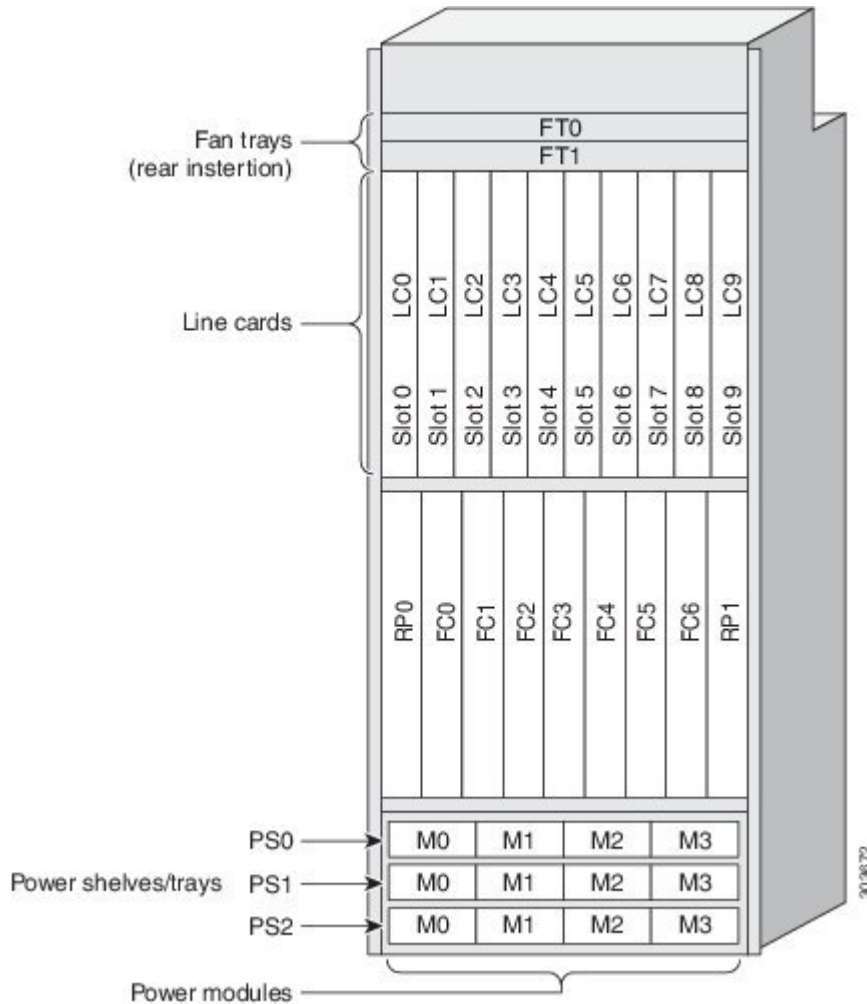
Figure 22: Cisco ASR 9910 Router Slot ID Numbering



Cisco ASR 9912 Router

The following figure shows slot numbering for the Cisco ASR 9912 Router with the DC power system. The numbering for the AC power system is the same but each tray only holds three power modules.

Figure 23: Cisco ASR 9912 Router Slot Numbering



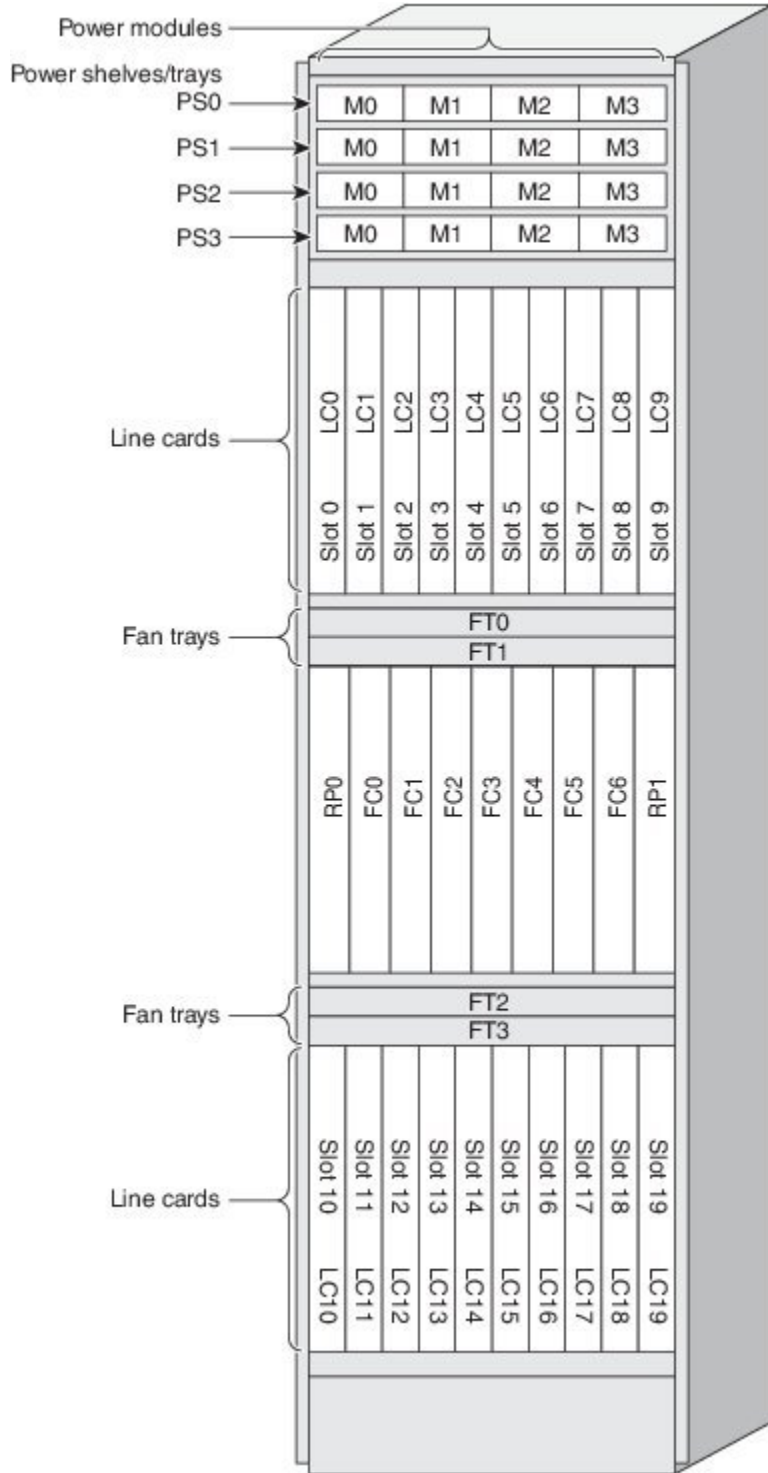
Cisco ASR 9922 Router

The following figure shows slot numbering for the Cisco ASR 9922 Router with version 2 or version 3 DC power trays. The numbering for the AC power system is the same but each tray only holds three power modules.



Note For the Cisco ASR 9922 Router, line cards must be installed upside down in slots 10 through 19 of the bottom card cage, whereas in slots 0 through 9 of the top card cage, the line cards are installed right side up.

Figure 24: Cisco ASR 9922 Router Slot Numbering



Route Switch Processor and Route Processor Cards

This section describes the Route Switch Processor (RSP) card and Route Processor (RP) card for the Cisco ASR 9000 Series Routers and includes the following sections:

Overview

The Route Switch Processor (RSP) card is the main control and switch fabric element in the Cisco ASR 9010 Router, Cisco ASR 9006 Router, Cisco ASR 9904 Router, Cisco ASR 9906 Router, and Cisco ASR 9910 Router. To provide redundancy, there can be two RSP cards in each router, one as the active control RSP and the other as the standby RSP. The standby RSP takes over all control functions if the active RSP fails.

The Route Processor (RP) card is the main control element in the Cisco ASR 9922 Router and Cisco ASR 9912 Router. The RP card provides centralized chassis control, management, and data-plane switching. To provide redundancy, there are two RP cards in each router, one as the active control RP and the other as the standby RP. The standby RP takes over all control functions should the active RP fail.

System alarms reside on the RSP. Alarms consist of visual indicators with three levels: Critical (red), Major (red), and Minor (yellow for RSP, amber for RP). There is a console interface for remote viewing of alarms and fault information.



Note The generic term RSP card refers to the RSP-440, RSP-440 Lite, RSP-880, RSP880-LT, RSP5, RSP5X and RSP4-S cards, unless otherwise specified. The generic term RP card refers to the RP card and RP2/RP3/RP3X card, unless otherwise specified.

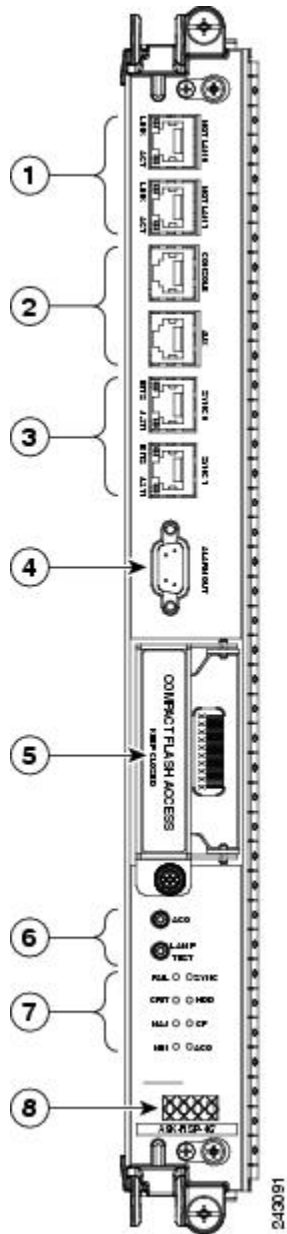
RSP Card Front Panel and Access Ports

The RSP has the following features:

- Two dual-speed 100/1000 Mbit Ethernet Management ports
- Two EIA/TIA-232 RJ232 serial RJ-45 ports—one each for Console and Auxiliary modem ports, with Manufacturing Test connections to the backplane
- Two RJ-45 Sync timing ports with Link and Fault LEDs built into the RJ-45
- Alarm Output DB9 port with three alarm outputs
- One external Compact Flash type I/II
- Alarm Cut Off (ACO) and Lamp Test momentary push buttons
- Eight discrete Status LED indicators
- One 4 character 5x7 LED dot matrix display and discrete status LEDs

The following figure shows the front panel and connectors of the RSP card.

Figure 25: RSP Card Front Panel Indicators and Connectors



1	Management LAN ports	5	Compact Flash type I/II
2	CONSOLE and AUX ports	6	Alarm Cutoff (ACO) and LAMP TEST p
3	SYNC (BITS/J.211) ports	7	Eight discrete LED indicators
4	Alarm Out DB9 connector	8	LED matrix display

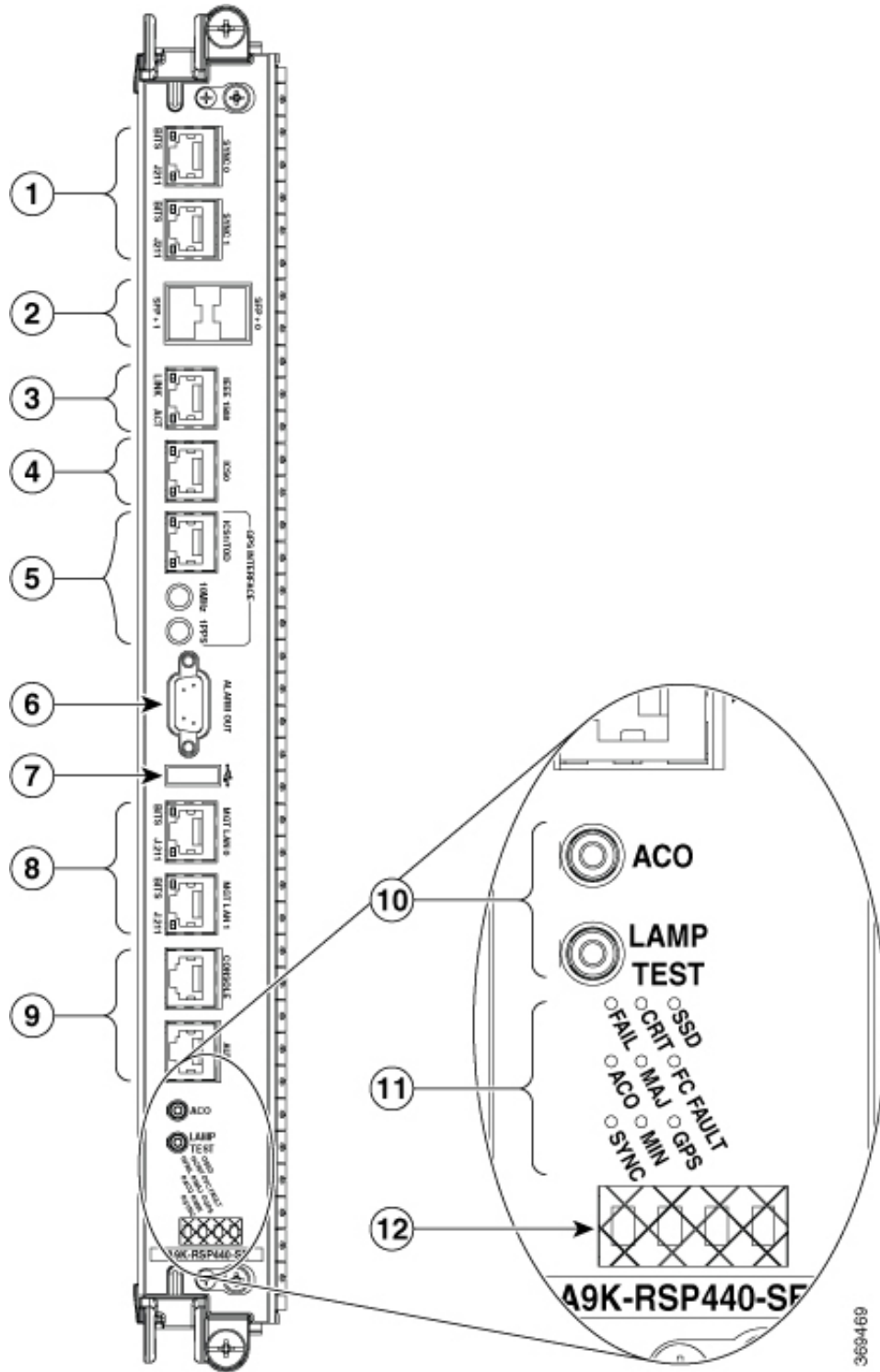
RSP-440 and RSP-440 Lite Front Panel and Access Ports

The RSP-440 and RSP-440 Lite cards have the following features:

- Two RJ-45 Sync timing ports with Link and Fault LEDs built into the RJ-45
- Two 10-GE Small Form-Factor Pluggable (SFP/SFP+) virtualization cluster ports
- IEEE1588 RJ-45 Timestamp port
- Two Inter-Chassis Sync ports—ICS1 is shared with RS232/422 GPS TOD RJ-45 port
- RS232/422 GPS TOD RJ-45 port for system timing input
- 10 MHz and 1 PPS clock input SMB ports
- Alarm Output DB9 port with three alarm outputs
- External USB2, class-A port
- Two dual-speed 100/1000 Mbit Ethernet Management ports
- Two EIA/TIA-232 RJ232 serial RJ-45 ports—one each for Console and Auxiliary modem ports, with Manufacturing Test connections to the backplane
- Alarm Cut Off (ACO) and Lamp Test momentary push buttons
- Nine discrete Status LED indicators
- One four-character 5x7 LED dot matrix display and discrete status LEDs

The following figure shows the front panel of the RSP-440 card.

Figure 26: RSP-440 Card Front Panel

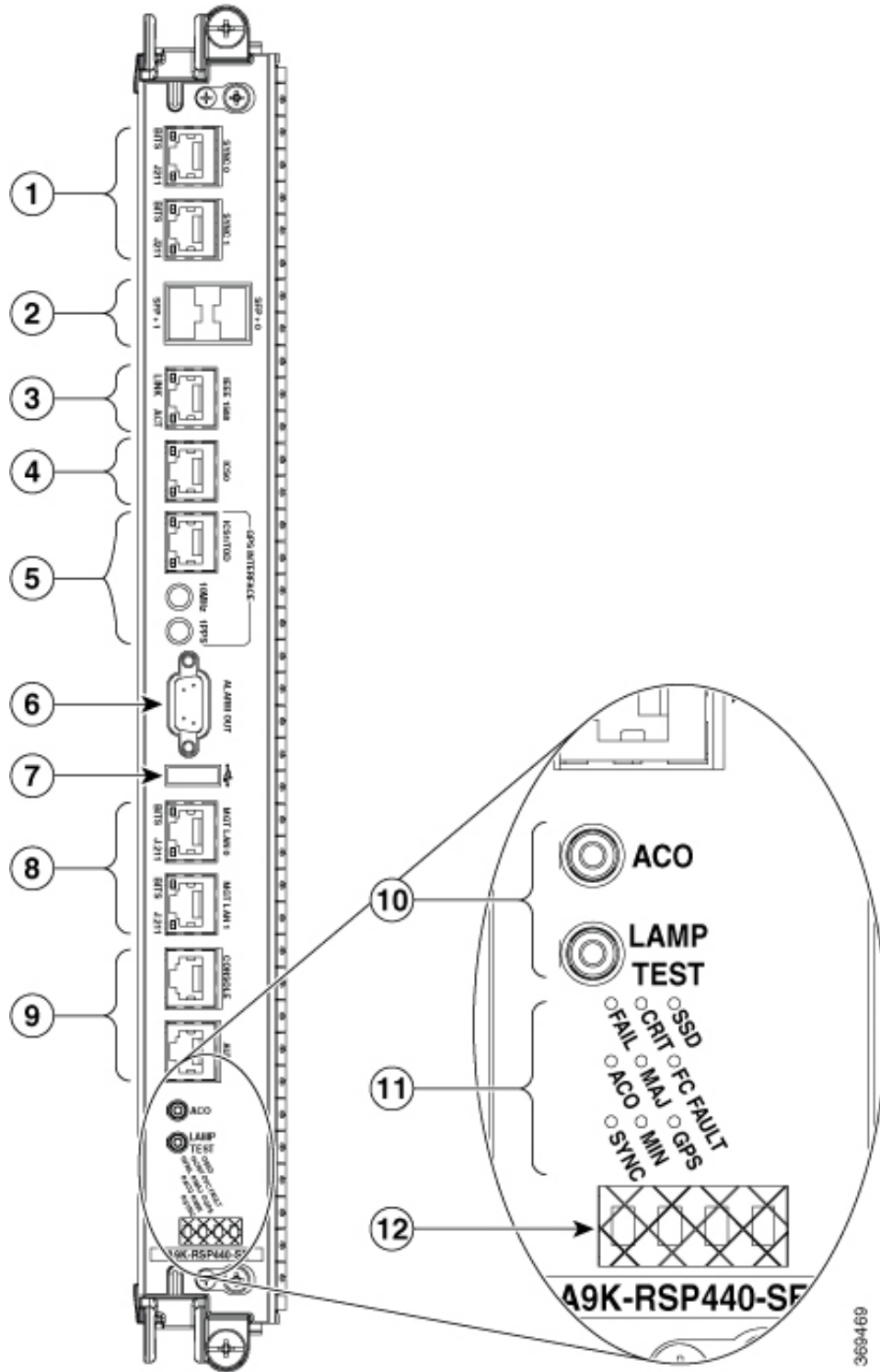


1	SYNC (BITS/J.211) ports	7	External USB port
---	-------------------------	---	-------------------

2	SFP/SFP+ ports	8	Management LAN ports
3	IEEE 1588 port	9	CONSOLE and AUX ports
4	ToD port	10	Alarm Cutoff (ACO) and LAMP TEST push
5	10 MHz and 1 PPS indicators	11	Nine discrete LED indicators
6	Alarm Out DB9 connector	12	LED matrix display

The following figure shows the front panel of the RSP-440 Lite card.

Figure 27: RSP-440 Lite Card Front Panel



1	SYNC (BITS/J.211) ports	7	External USB port
---	-------------------------	---	-------------------

2	SFP ports	8	Management LAN ports
3	IEEE 1588 port	9	CONSOLE and AUX ports
4	ToD port	10	Alarm Cutoff (ACO) and LAMP TEST push
5	10MHz and 1PPS indicators	11	Nine discrete Status LED indicators
6	Alarm Out DB9 connector	12	LED matrix display

RSP-880 and RSP880-LT Card Front Panel and Access Ports

The RSP-880 and RSP880-LT has the following features:

- Two RJ-45 Sync timing ports with Link and Fault LEDs built into the RJ-45
- Four 10-GE Small Form-Factor Pluggable (SFP/SFP+) virtualization cluster ports on the RSP-880

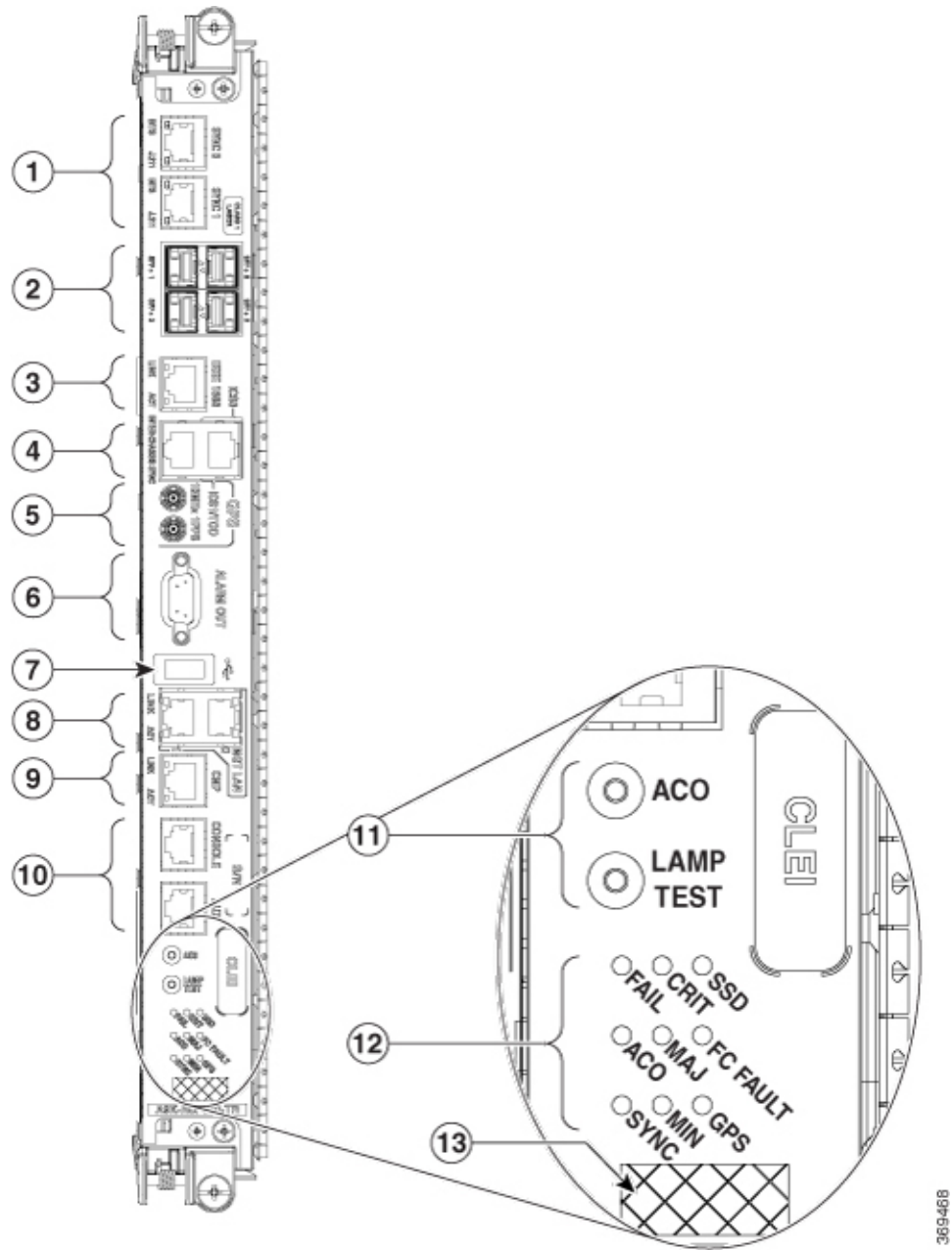


Note The RSP880-LT does not have cluster ports.

- IEEE1588 RJ-45 Timestamp port
- Two Inter-Chassis Sync ports—nVSync1 is shared with RS232/422 GPS TOD RJ-45 port
- RS232/422 GPS TOD RJ-45 port for system timing input
- 10 MHz and 1 PPS clock input SMB ports
- Alarm Output DB9 port with three alarm outputs
- External USB2, class-A port
- Two dual-speed 100/1000 Mbit Ethernet Management ports
- One Connectivity Management Processor (CMP) port
- Two EIA/TIA-232 RJ232 serial RJ-45 ports—one each for Console and Auxiliary modem ports, with Manufacturing Test connections to the backplane
- Alarm Cut Off (ACO) and Lamp Test momentary push buttons
- Nine discrete Status LED indicators
- One four-character 5x7 LED dot matrix display and discrete status LEDs

The following figure shows the front panel of the RSP-880 card.

Figure 28: RSP-880 Card Front Panel

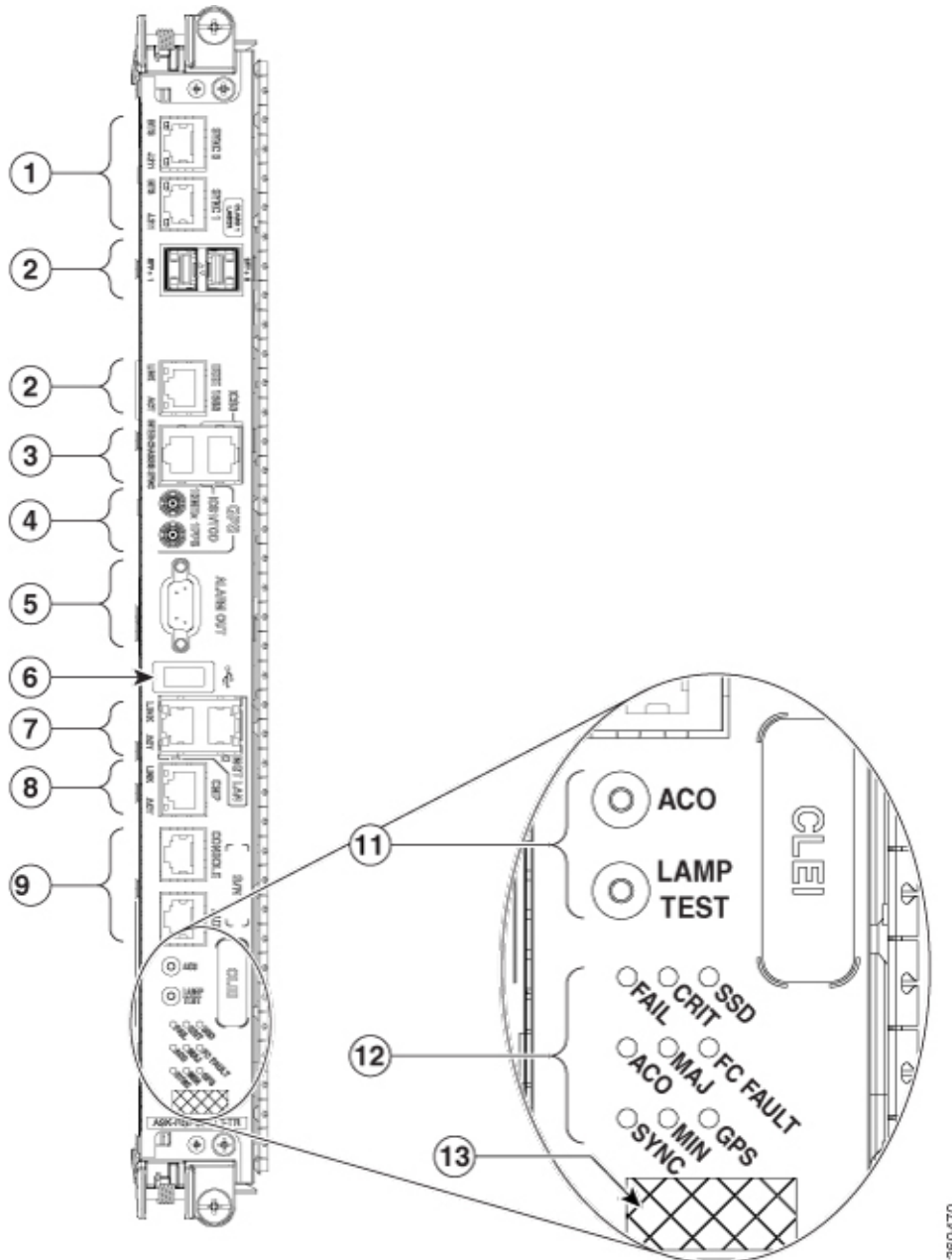


1	SYNC (BITS/J.211) ports	8	Management LAN ports
2	SFP/SFP+ ports	9	CMP port
3	Service LAN port	10	Console and Auxiliary (AUX) ports
4	Inter Chassis Sync ports and ToD port	11	Alarm Cutoff (ACO) and Lamp Test push
5	10 MHz and 1 PPS indicators	12	Nine discrete LED indicators

6	Alarm Out DB9 connector	13	LED matrix display
7	External USB port		

The following figure shows the front panel of the RSP880-LT card.

Figure 29: RSP880-LT Card Front Panel



1	SYNC (BITS/J.211) ports	7	Management LAN ports
---	-------------------------	---	----------------------

2	Service LAN port	8	CMP port
3	Inter Chassis Sync ports and ToD port	9	Console and Auxiliary (AUX) ports
4	10 MHz and 1 PPS indicators	10	Alarm Cutoff (ACO) and Lamp Test push
5	Alarm Out DB9 connector	11	Nine discrete LED indicators
6	External USB port	12	LED matrix display

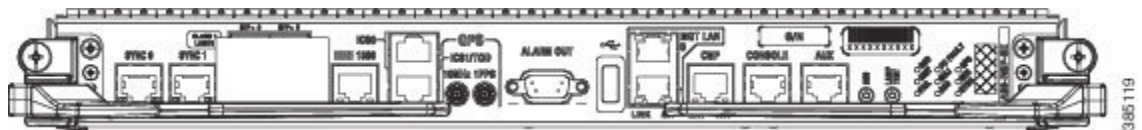
RSP4-S Card Front Panel and Access Ports

The RSP4-S has the following features:

- Two RJ-45 Sync timing ports with Link and Fault LEDs built into the RJ-45
- Four 10-GE Small Form-Factor Pluggable (SFP/SFP+) virtualization cluster ports
- IEEE1588 RJ-45 Timestamp port
- Two Inter-Chassis Sync ports—nVSync1 is shared with RS232/422 GPS TOD RJ-45 port
- RS232/422 GPS TOD RJ-45 port for system timing input
- 10 MHz and 1 PPS clock input SMB ports
- Alarm Output DB9 port with three alarm outputs
- External USB2, class-A port
- Two dual-speed 100/1000 Mbit Ethernet Management ports
- One Connectivity Management Processor (CMP) port
- Two EIA/TIA-232 RJ232 serial RJ-45 ports—one each for Console and Auxiliary modem ports, with Manufacturing Test connections to the backplane
- Alarm Cut Off (ACO) and Lamp Test momentary push buttons
- Nine discrete Status LED indicators
- One four-character 5x7 LED dot matrix display and discrete status LEDs

The following figure shows the front panel of the RSP4-S card.

Figure 30: RSP4-S Card Front Panel



RSP5 Card Front Panel and Access Ports

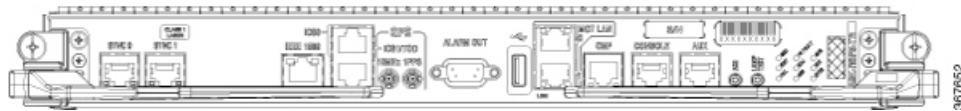
The RSP5 has the following features:

- Two RJ-45 Sync timing ports with Link and Fault LEDs built into the RJ-45

- IEEE1588 RJ-45 Timestamp port
- Two Inter-Chassis Sync ports—nVSync1 is shared with RS232/422 GPS TOD RJ-45 port
- RS232/422 GPS TOD RJ-45 port for system timing input
- 10 MHz and 1 PPS clock input SMB ports
- Alarm Output DB9 port with three alarm outputs
- External USB2, class-A port
- Two dual-speed 100/1000 Mbit Ethernet Management ports
- One Connectivity Management Processor (CMP) port
- Two EIA/TIA-232 RJ232 serial RJ-45 ports—one each for Console and Auxiliary modem ports, with Manufacturing Test connections to the backplane
- Alarm Cut Off (ACO) and Lamp Test momentary push buttons, which can be used to eject the RSP5 card.
- Nine discrete Status LED indicators
- One four-character 5x7 LED dot matrix display and discrete status LEDs

The following figure shows the front panel of the RSP5 card.

Figure 31: RSP5 Card Front Panel



RSP5-X Card Front Panel and Access Ports

Table 3: Feature History Table

Hardware	Release Information	Description
RSP5-X Route Switch Processor	Release 7.6.2	<p>This release introduces the following 5th generation Route Switch Processor RSP5-X cards:</p> <ul style="list-style-type: none"> • A9K-RSP5-X-TR • A9K-RSP5-X-SE <p>RSP5-X card functions as the main control, switch fabric and timing synchronization entity for the following routers:</p> <ul style="list-style-type: none"> • ASR 9006 • ASR 9010 • ASR 9904 • ASR 9906 • ASR 9910 <p>RSP5-X is the first RSP to support Class-C timing performance and is backward compatible with RSP5, it also supports Cisco Secure Boot and can operate with 25% lower power consumption over RSP5.</p> <p>For information regarding the migration procedure, see Cisco ASR 9000 Series Aggregation Services Router Hardware Installation Guide.</p>

The RSP5-X card has the following features:

- Two RJ-45 SYNC (BITS) ports with Link and Fault LEDs built into the RJ-45
- One 10-GbE Small Form-Factor Pluggable (SFP/SFP+) port
- RS-422 GPS TOD RJ-45 port for system timing input
- 10 MHz and 1 PPS input and output DIN ports
- Alarm Output DB9 port with three alarm outputs
- External USB2, class-A port
- Two 100/1000 Mbit Ethernet Management LAN ports

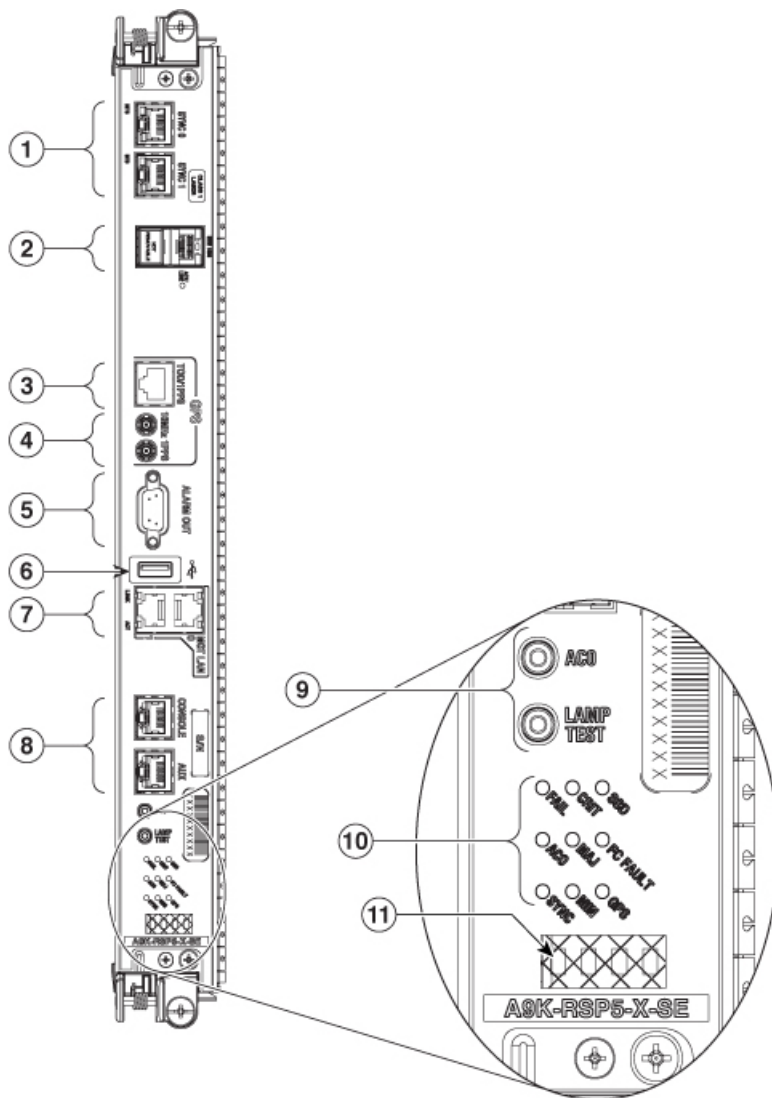
- Two EIA/TIA-232 RS-232 serial RJ-45 ports - one each for Console and Auxiliary modem ports
- Alarm Cut Off (ACO) and Lamp Test momentary push buttons
- Nine discrete Status LED indicators
- One four-character 5x7 LED dot matrix display



Note 10-GbE SFP/SFP+ port is not supported with the IOS XR release 7.6.2.

The following figure shows the front panel of the RSP5-X card.

Figure 32: RSP5-X Card Front Panel



1	SYNC (BITS) ports	7	Management LAN ports
---	-------------------	---	----------------------

2	SFP/SFP+ port	8	CONSOLE and AUX ports
3	ToD port	9	Alarm Cutoff (ACO) and LAMP TEST p
4	10 MHz and 1 PPS ports	10	Nine discrete LED indicators
5	Alarm Out DB9 connector	11	LED matrix display
6	External USB port		

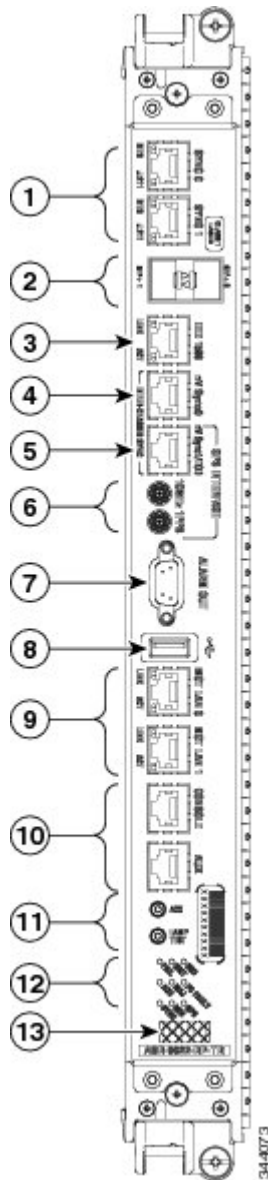
RP Card and RP2 Card Front Panel and Access Ports

The RP and RP2 front panel has the following information and alarm LEDs and connectors:

- Two BITS RJ-45 Sync timing ports
- Two 10 GE SFP/SFP+ ports
- IEEE1588 RJ-45 Timestamp port
- RS232/422 GPS TOD RJ-45 port for system timing input
- 10 MHz and 1 PPS clock input SMB ports
- Alarm Output DB9 port with three alarm outputs
- External USB2, class-A port
- Two RJ-45 100/1000 Mbit Ethernet Management ports
- One Connectivity Management Processor (CMP) port (RP2 card only)
- RJ-45 Console port
- RJ-45 Auxiliary (AUX) port
- Alarm Cut Off (ACO) and Lamp Test momentary push buttons
- RP Discrete Status LEDs
 - SSD LED
 - FC Fault LED
 - GPS LED
 - Critical Alarm LED (red)
 - Major Alarm LED (red)
 - Minor Alarm LED (amber)
 - Power Fail LED
 - ACO LED (amber)
 - SYNC LED (green and amber)
- One 4-character 5x7 LED dot-matrix display

The following figure shows the front panel of the RP card.

Figure 33: RP Card Front Panel

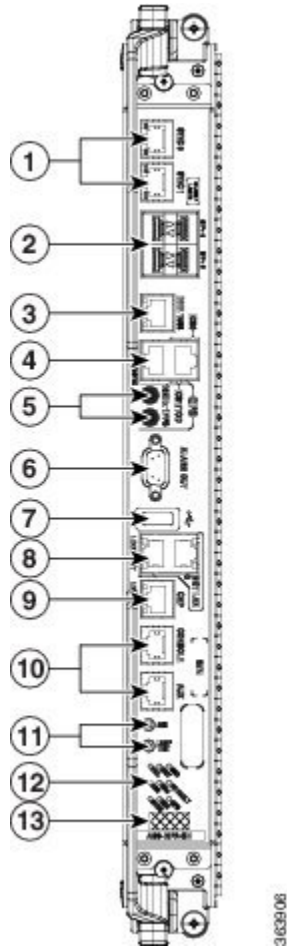


1	SYNC (BITS/J.211) ports	8	External USB port
2	SFP/SFP+ ports	9	Management LAN ports
3	IEEE 1588 port	10	CONSOLE and AUX ports
4	Inter-chassis nv Sync0	11	Alarm Cutoff (ACO) and Lamp Test push buttons
5	Inter-chassis nv Sync1 GPS ToD	12	Nine discrete LED indicators
6	10 MHz and 1 PPS indicators	13	LED matrix display

7	Alarm Out DB9 connector		
---	-------------------------	--	--

The following figure shows the front panel of the RP2 card.

Figure 34: RP2 Card Front Panel



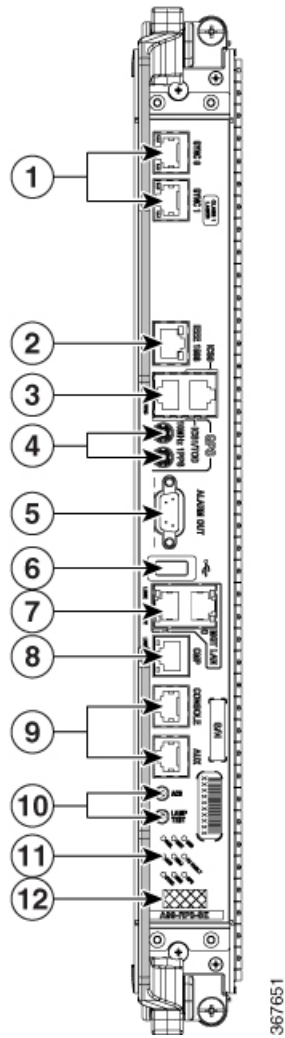
1	SYNC (BITS/J.211) ports	8	Management LAN ports
2	SFP/SFP+ ports	9	CMP Port
3	IEEE 1588 port	10	CONSOLE and AUX ports
4	Inter-chassis nv Sync0 and 1	11	Alarm Cutoff (ACO) and Lamp Test push
5	10 MHz and 1 PPS indicators	12	Nine discrete Status LED indicators
6	Alarm Out DB9 connector	13	LED matrix display
7	External USB port		

RP3 Card Front Panel and Access Ports

The RP3 front panel has the following information and alarm LEDs and connectors:

- Two BITS RJ-45 Sync timing ports
- IEEE1588 RJ-45 Timestamp port
- RS232/422 GPS TOD RJ-45 port for system timing input
- 10 MHz and 1 PPS clock input SMB ports
- Alarm Output DB9 port with three alarm outputs
- External USB2, class-A port
- Two RJ-45 100/1000 Mbit Ethernet Management ports
- One Connectivity Management Processor (CMP) port (RP2 card only)
- RJ-45 Console port
- RJ-45 Auxiliary (AUX) port
- Alarm Cut Off (ACO) and Lamp Test momentary push buttons
- RP Discrete Status LEDs
 - SSD LED
 - FC Fault LED
 - GPS LED
 - Critical Alarm LED (red)
 - Major Alarm LED (red)
 - Minor Alarm LED (amber)
 - Power Fail LED
 - ACO LED (amber)
 - SYNC LED (green and amber)
- One 4-character 5x7 LED dot-matrix display

The following figure shows the front panel of the RP3 card.



1	SYNC (BITS/J.211) ports	7	Management LAN ports
2	IEEE 1588 port	8	CMP Port
3	Inter-chassis nv Sync0 and 1	9	CONSOLE and AUX ports
4	10 MHz and 1 PPS indicators	10	Alarm Cutoff (ACO) and Lamp Test push
5	Alarm Out DB9 connector	11	Nine discrete Status LED indicators
6	External USB port	12	LED matrix display

RP3-X Card Front Panel and Access Ports

Hardware	Release Information	Description
RP3-X Route Processor	Release 7.6.2	<p>This release introduces the following 3rd generation Route Processor RP3-X cards:</p> <ul style="list-style-type: none"> • A99-RP3-X-TR • A99-RP3-X-SE <p>RP3-X card functions as the main control and timing synchronization entity for the following routers:</p> <ul style="list-style-type: none"> • ASR 9912 • ASR 9922 <p>RP3-X is the first RP to support Class-C timing performance and is backward compatible with RP3, it also supports Cisco Secure Boot and can operate with 20% lower power consumption over RP3.</p> <p>For information regarding the migration procedure, see Cisco ASR 9000 Series Aggregation Services Router Hardware Installation Guide.</p>

The RP3-X front panel has the following information and alarm LEDs and connectors:

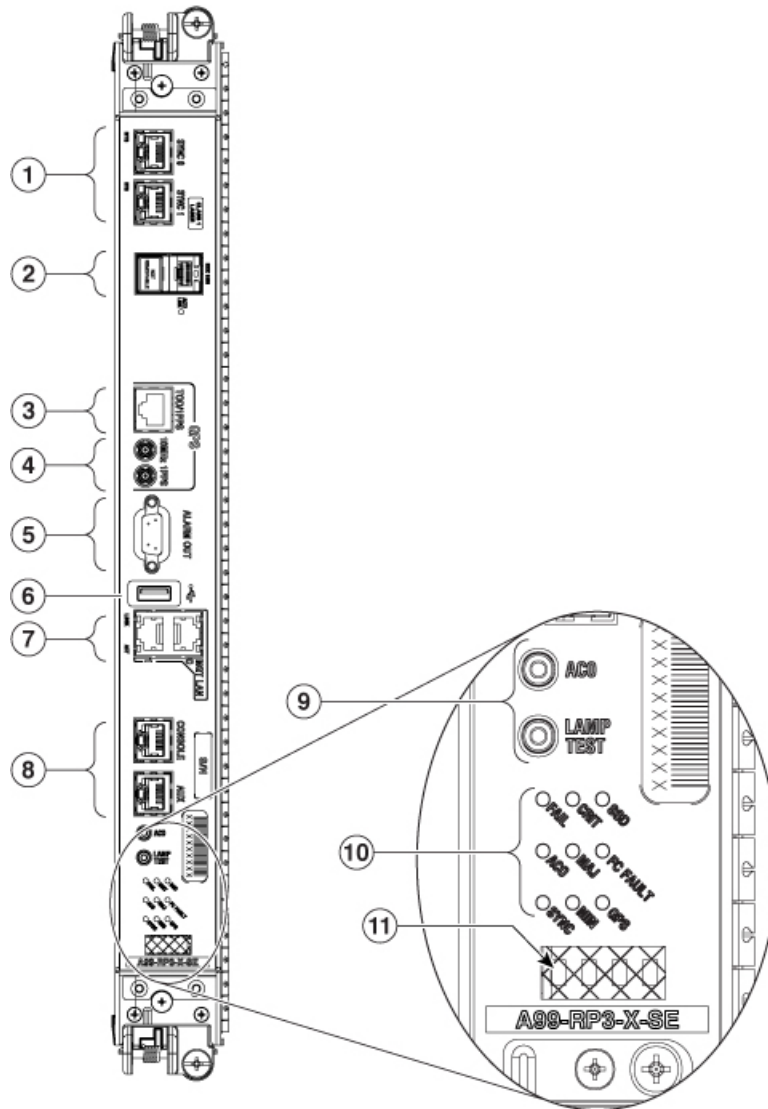
- Two RJ-45 SYNC (BITS) ports with Link and Fault LEDs built into the RJ-45
- One 10-GbE Small Form-Factor Pluggable (SFP/SFP+) port
- RS-422 GPS TOD RJ-45 port for system timing input
- 10 MHz and 1 PPS input and output DIN ports
- Alarm Output DB9 port with three alarm outputs
- External USB2, class-A port
- Two 100/1000 Mbit Ethernet Management LAN ports
- Two EIA/TIA-232 RS-232 serial RJ-45 ports - one each for Console and Auxiliary modem ports
- Alarm Cut Off (ACO) and Lamp Test momentary push buttons
- Nine discrete Status LED indicators
- One four-character 5x7 LED dot matrix display



Note 10-GbE SFP/SFP+ port is not supported with the IOS XR release 7.6.2.

The following figure shows the front panel of the RP3-X card.

Figure 35: RP3-X Card Front Panel



1	SYNC (BITS) ports	7	Management LAN ports
2	SFP/SFP+ port	8	CONSOLE and AUX ports
3	ToD port	9	Alarm Cutoff (ACO) and LAMP TEST p
4	10 MHz and 1 PPS ports	10	Nine discrete LED indicators

5	Alarm Out DB9 connector	11	LED matrix display
6	External USB port		

RSP and RP Front Panel Connectors

Management Ports

Two dual-speed management LAN ports (MGT LAN 0, MGT LAN 1) are triple-speed RJ-45 connectors for use as out-of-band management ports. The speed of the management LAN is auto-negotiated.



Note In 32-bit IOS XR OS, the management interfaces are available from XR VM. In 64-bit IOS XR OS, the Management ports on the RP/RSP are available as follows:

- MGT LAN 0 is available in XR VM.
- MGT LAN 1 is available in Admin VM.

Auxiliary (AUX) Port and Console Port

An RJ-45 Auxiliary (AUX) port and RJ-45 Console port are EIA/TIA-232 (also known as RS-232) asynchronous serial ports for connecting external devices to monitor and manage the system.

The console port provides a Data Circuit-Terminating Equipment (DCE) interface for connecting a console terminal. The default port settings are:

- For RP2 and RSP4, the console settings are baud rate 9600 bps, no parity, 1 stop bits and 8 data bits
- For RP3 and RSP5, the console settings are baud rate 115200 bps, no parity, 1 stop bits and 8 data bits.

For chassis with RSP4, RP2 cards, the console settings are baud rate 9600 bps, no parity, 1 stop bits and 8 data bits. The user can change this baud rate. For next generation RP3, RSP5 cards, the console settings are baud rate 115200 bps, no parity, 1 stop bits and 8 data bits, the default baud rate can't be changed for RP3 and RSP5.

The auxiliary port provides a data circuit-terminating equipment (DCE) interface that supports flow control. Use this port to connect a modem, a channel service unit (CSU), or other optional equipment for Telnet management. This port defaults to 9600 Baud, 8 data, no parity, 1 stop bit with software handshake.

Synchronization Ports

The RSP/RP card front panel also has a two synchronization (SYNC) timing ports that can be configured as BITS or J.211 ports. These ports provide connections for external timing and synchronization sources

The SYNC 0 and SYNC 1 ports are timing ports that can be configured as Building Integrated Timing System (BITS) ports. A BITS port provides a connection for an external synchronization source to establish precise frequency control at multiple network nodes, if required for your application. The RSP/RP card contains a Synchronous Equipment Timing Source (SETS) that can receive a frequency reference from an external BITS timing interface or from a clock signal recovered from any incoming interface, such as a Gigabit Ethernet,

10-Gigabit Ethernet, or SONET interface. The RSP/RP SETS circuit filters the received timing signal and uses it to drive an outgoing Ethernet interface or BITS output port.

The timing port(s) can also be configured as J.211 or DTI ports. A DOCSIS Timing Interface (DTI) port is used to connect to an external DTI server to synchronize timing and frequency across multiple routers. The timing function allows precise synchronization of real-time clocks in a network for measurements of network performance, for example, measuring delay across a VPN. The frequency reference acts like a BITS input.

Alarm Connector

Each RSP/RP card drives a set of three alarm output contacts. Alarm circuitry on the RSP/RP activates dry contact closures that are accessible through the nine-pin Alarm Out connector on the RSP/RP front panel. Each RSP/RP card drives a set of three alarm output contacts. Both normally-open and normally-closed contacts are available.

Only the active RSP/RP drives the alarm outputs. Should a switchover to the standby RSP/RP occur, the newly active RSP/RP drives the alarm outputs.

SFP/SFP+ Port

The RSP-440 and RSP-440 Lite support two 10-GE Small Form-Factor Pluggable Plus (SFP+) virtualization cluster ports. The RSP-880 supports four 10-GE SFP+ ports that are used for external server connectivity capability.

GPS Interface

The RSP-440, RSP-440 Lite, RSP880-LT, and RSP-880 have a Time of Day (ToD) port, 10-MHz connector, and 1-PPS connector that allow you to configure input or output clocking with a GPS device.

Inter Chassis Synchronization Port

The nV Sync 0 and nV Sync 1 ports on the RSP-440, RSP-440 Lite, RSP880-LT, and RSP-880 are the RJ-45 inter-chassis synchronization clock interfaces for synchronizing frequency and time.

CMP Port

The Connectivity Management Processor (CMP) on the RSP-880 card, RSP880-LT, and RP2 card is a secondary, lightweight processor that provides a second network interface to the system. Each CMP contains its own RAM, bootflash, and front panel management Ethernet port.

The CMP port provides the following functions:

- RSP-880, RSP880-LT, and RP2 ROMMON console access through the CMP port. This eliminates the need to use external terminal servers.
- SSH/telnet into a designated CMP port.

USB Port

The RSP-440, RSP-440 Lite, RSP-880, RSP880-LT, and RP cards have a single external Universal Serial Bus (USB) port. A USB flash memory device can be inserted to load and transfer software images and files. This memory device can be used to turboboot the system or as the installation source for Package Information Envelopes (PIE) and Software Maintenance Upgrades (SMU). This memory device can also be used for users' data files, core files, and configuration backups.

Push Buttons

Two push buttons are provided on the RSP/RP card front panel.

- Alarm Cutoff (ACO)—ACO activation suppresses alarm outputs. When the ACO button is pushed while critical alarms are active, the ACO LED turns on, and the corresponding alarm output contacts revert to the normally open (non-alarm) state, thus suppressing the alarm. If subsequent critical alarms are detected and activated after the ACO activation, the ACO function is deactivated to notify the user of the arrival of the new alarm(s). In this case, the ACO LED will turn off and any active alarms are again indicated by driving their alarm output contacts to the alarm state.
- Lamp Test—When the Lamp Test button is pushed, the RSP/RP status LED, line card status and port LEDs, and Fan Tray LEDs light until the button is released. The LED matrix display is not affected.

RSP and RP Front Panel Indicators

The RSP card has eight discrete LED indicators and an LED dot-matrix display for system information. The RSP-440, RSP-440 Lite, RSP880-LT, RSP5 and RSP-880 have nine discrete LED indicators, a LED dot-matrix display for system information, and three USB-specific LEDs. The RP has nine discrete LED indicators and a LED dot-matrix display for system information.

The following table lists the display definitions of the discrete LEDs on the various RSP front panels and the three USB LEDs on the RSP-440, RSP-440 Lite, RSP5, and RSP-880.

Table 4: RSP, RSP-440, RSP-440 Lite, RSP-880, RSP880-LT, RSP4-S, RSP5 Discrete LED Display Definitions

Indicator (Label)	Color	Description
Power Fail (FAIL)	Red	Standby Power Fail LED. The LED is turned off by the CAN bus controller after it is up and running.
	Off	Standby power is normal.
Critical Alarm (CRIT)	Red	Critical Alarm LED. A critical alarm has occurred.
	Off (Default after reset)	No critical alarm has occurred.
Major Alarm (MAJ)	Red	Major alarm LED. A major alarm has occurred.
	Off (Default after reset)	No major alarm has occurred.
Minor Alarm (MIN)	Amber	Minor alarm LED. A minor alarm has occurred.
	Off (Default after reset)	No minor alarm has occurred.
Synchronization (SYNC)	Green	System timing is synchronized to an external timing source.
	Amber	System timing is free running.
	Off	No system timing is configured.
Alarm Cutoff (ACO)	Amber	Alarm Cutoff has been enabled. The ACO push button was pressed after at least one alarm has occurred.
	Off (Default after reset)	Alarm Cutoff is not enabled.

Indicator (Label)	Color	Description
Internal Hard Disk Drive (HDD) [RSP only]	Green	Hard Disk Drive is busy/active. The LED is driven by the SAS controller.
	Off (Default after reset)	Hard Disk Drive is not busy/active
External Compact Flash (CF) [RSP only]	Green	Compact Flash is busy/active.
	Off (Default after reset)	Compact Flash is not busy/active.
Internal Solid State Hard Disk Drive (SSD) RSP-440/RSP-440 Lite, RSP-880/RSP880-LT,RSP5	Green	Internal Solid State Hard Disk Drive (SSD0) is busy/active. The LED is driven by the SSD/SAS controller.
	Off (Default after reset)	Internal Solid State Hard Disk Drive is not busy/active.
GPS RSP-440/RSP-440 Lite, RSP-880/RSP880-LT, RSP5	Green	GPS interface provisioned and ports are turned on. ToD, 1 PPS, 10 Mhz are all valid.
	Off(Default after reset)	Either the interface is not provisioned, or the ports are not turned on. ToD, 1 PPS, 10 Mhz are not valid.
External USB 2.0 RSP-440/RSP-440 Lite, RSP-880/RSP880-LT, RSP5	Green	External USB is busy/active.
	Off (Default after reset)	External USB is not busy/active.
Internal USB 2.0 A RSP-440/RSP-440 Lite, RSP-880/RSP880-LT, RSP5	Green	Internal USB is busy/active.
	Off (Default after reset)	Internal USB is not busy/active.
Internal USB 2.0 B RSP-440/RSP-440 Lite, RSP-880/RSP880-LT, RSP5	Green	Internal USB is busy/active.
	Off (Default after reset)	Internal USB is not busy/active.

The following table lists the display definitions of the nine discrete LEDs on the RP front panel.

Table 5: RP and RP2/RP3 Discrete LED Display Definitions

Indicator (Label)	Color	Description
Power Fail (FAIL)	Red (Default after power on)	Standby Power Fail LED. The LED is turned off by the CAN bus controller after it is up and running.
	Off	Standby power is normal.
Critical Alarm (CRIT)	Red	Critical Alarm LED. A critical alarm has occurred.
	Off (Default after reset)	No critical alarm has occurred.

Indicator (Label)	Color	Description
Major Alarm (MAJ)	Red	Major alarm LED. A major alarm has occurred.
	Off (Default after reset)	No major alarm has occurred.
Minor Alarm (MIN)	Amber	Minor alarm LED. A minor alarm has occurred.
	Off (Default after reset)	No minor alarm has occurred.
Alarm Cutoff (ACO)	Amber	Alarm Cutoff has been enabled. The ACO push button was pressed after at least one alarm has occurred.
	Off (Default after reset)	Alarm Cutoff is not enabled.
Synchronization (SYNC)	Green	System timing is synchronized to an external timing source including IEEE 1588.
	Amber	System timing is free running.
	Off (Default after reset)	LED never turns off.
Internal Solid State Hard Disk Drive (SSD)	Green	Internal Solid State Hard Disk Drive (SSD0) is busy/active. The LED is driven by the SSD controller.
	Off (Default after reset)	Internal Solid State Hard Disk Drive is not busy/active.
FC Fault	Amber	A fault has occurred on any or all of the FC cards installed. This LED will be on during the boot phase of the FC.
	Off (Default after reset)	FC cards are booted up and ready.
GPS	Green	GPS interface provisioned and ports are turned on. ToD, 1 PPS, 10 Mhz are all valid.
	Off (Default after reset)	Either the interface is not provisioned, or the ports are not turned on. ToD, 1 PPS, and 10 Mhz are not valid.

LED Matrix Display

The LED matrix displays one row of four characters. The matrix becomes active when the CPU powers on and displays the stages of the boot process, as well as displaying runtime information during normal operation. If there are CAN Bus Controller problems, error messages are displayed.

LED Matrix Boot Stage and Runtime Display

The following tables describe the boot process and runtime display information for the RSP/RP cards.

Not all of these messages are seen during a successful boot up process because the screen is updated too quickly for the message to be visible. A failure detected during the boot up process results in the message remaining visible indicating the stage where the boot up process stopped. When possible, the RSP/RP card logs the failure information and reboots.

Table 6: (Cisco IOS XR 32-Bit Software) RSP-440, RSP-440 Lite, RSP-880, RSP880-LT, RSP4-S, RP/RP2 LED Matrix Boot Stages and Runtime Displays

LED Matrix Display	Description
INIT	Card is inserted and microcontroller is initialized.
BOOT	Card is powered on and CPU is booting.
IMEM	Starting initialization of memory.
IGEN	Starting initialization of card.
ICBC	Initializing communication with the microcontroller.
SCPI	Board is not plugged in properly.
STID	CBC was unable to read slot ID pins correctly.
PSEQ	CBC detected power sequencer failure.
DBPO	CBC detected an issue during board power up.
KPWR	CBC detected an issue during board power up.
LGNP	CBC detected an issue during board power up.
LGNI	CBC detected an issue during board power up.
IPNP (RSP-880/RSP880-LT/RP2 only)	CBC detected an issue during board power up.
IPNI (RSP-880/RSP880-LT/RP2 only)	CBC detected an issue during board power up.
RMN	All tests finished and ROMMON is ready for commands.
LOAD	Downloading Minimum Boot Image (MBI) image to CPU.
RRST	ROMMON rebooting board after MBI validation timeout.
MVB	ROMMON trying MBI validation boot.
MBI	Starting execution of MBI.
IOXR	Cisco IOS XR Software is starting execution.
LDG	The RSP/RP is loading (MBI started and card preparing for activity).
INCP	The software or configuration is incompatible with the RSP/RP.
OOSM	The RSP/RP is in Out of Service, Maintenance mode.
ACT	The RSP/RP is active (IOS-XR completely up and ready for traffic)

LED Matrix Display	Description
STBY	The RSP/RP is standby (IOS-XR completely up and ready)
AUTH	The RSP-880/RSP880-LT card or RP2 card failed anti-counterfeiting authentication and rebooted. If authentication continues to fail, the card will be in a continuous reboot loop.

Table 7: (Cisco IOS XR 64-Bit Software) RP2/RP3, RSP880, RSP4-Lite, RSP4-S, RSP5 LED Matrix Boot Stages and Runtime Displays

LED Matrix Display	Description
INIT	Card is inserted and microcontroller is initialized.
BOOT	Card is powered on and CPU is booting.
IMEM	Starting initialization of memory.
IGEN	Starting initialization of card.
ICBC	Initializing communication with the microcontroller.
SCPI	Board is not plugged in properly.
STID	CBC was unable to read slot ID pins correctly.
PSEQ	CBC detected power sequencer failure.
DBPO	CBC detected an issue during board power up.
KPWR	CBC detected an issue during board power up.
LGNP	CBC detected an issue during board power up.
LGNI	CBC detected an issue during board power up.
IPNP (RSP-880/RSP880-LT/RSP5/RP2/RP3 only)	CBC detected an issue during board power up.
IPNI (RSP-880/RSP880-LT/RSP5/RP2/RP3 only)	CBC detected an issue during board power up.
AUTH	The RSP-880/RSP880-LT/RSP5 card or RP2/RP3 card failed anti-counterfeiting authentication and rebooted. If authentication continues to fail, the card will be in a continuous reboot loop.
OPER	The RP admin plane is up and operational
LOCK	The RP is either upgrading an FPD on a local board or on a non-CPU based board. Reload cannot be executed during this time.
OFF	RP is currently shutdown.

LED Matrix Display	Description
EJCT	RP Ejector button pressed (applicable to RSP5).
SINI	RP admin plane software init state. This would be seen just before the admin plane goes OPERATIONAL.
PXE	RP is pxe booting image.
DISK	RP is booting image from disk.

LED Matrix CAN Bus Controller Error Display

The following table shows the error messages the LED matrix displays if the RSP card fails one of the power on self tests.

Table 8: RSP LED Matrix CAN Bus Controller Status Display

LED Matrix Display	Description
PST1	Failed DDR RAM memory test
PST2	Failed FPGA image cyclic redundancy checking (CRC) check
PST3	Failed card type and slot ID verification

RSP and RP Card Ejector Levers

Ejector levers are provided for inserting and removing the RSP/RP cards. The insertion and removal force of the card ejector levers is about 16 lbs (7.27 kg). Longer ejector levers are provided for the RSP/RP cards than for the line cards due to the higher pin count of the RSP/RP card.

Serviceability

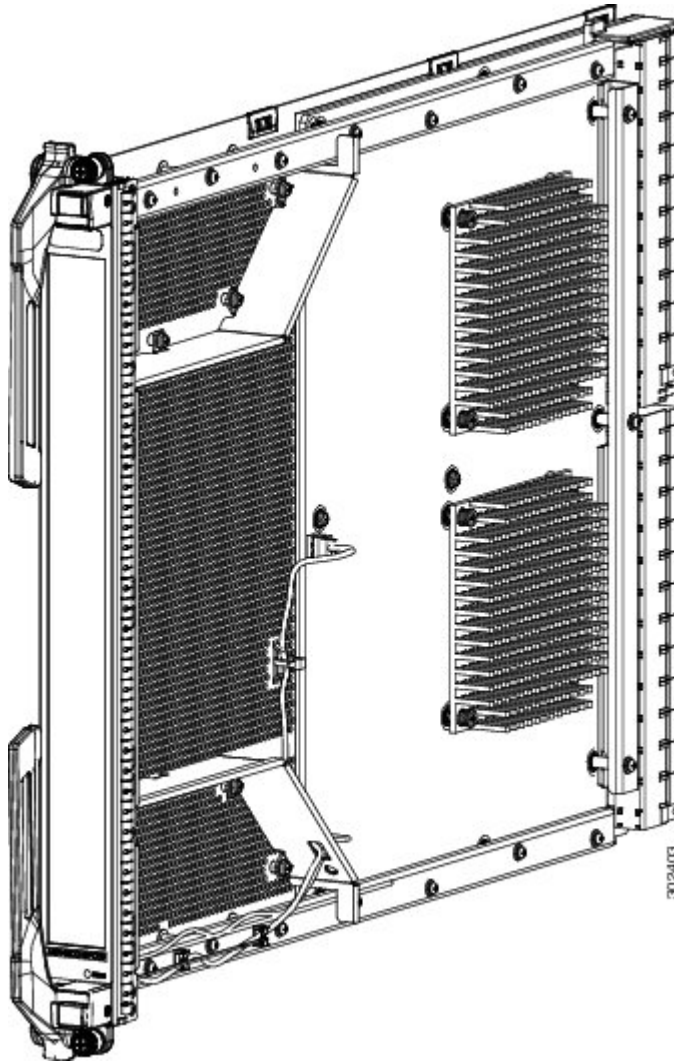
RSP/RP cards can be inserted or removed when adjacent (cabled) RSP/RP or line cards are installed. Compact Flash is serviceable without the need to remove the RSP card. Servicing the hard drive requires removal of the RSP/RP card.

Fabric Controller Card

On the Cisco ASR 9906 Router, Cisco ASR 9910 Router, Cisco ASR 9922 Router and Cisco ASR 9912 Router, the switch fabric resides on the FC cards.

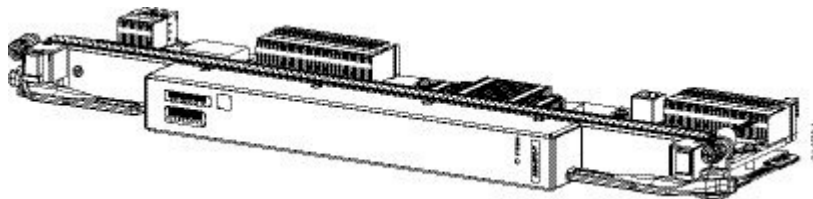
The following figure shows the FC card. The FC2/A99-SFC3 card is similar.

Figure 36: FC Card



The following figure shows the SFC-T card (for the ASR 9906).
A99-SFC3-T card is similar.

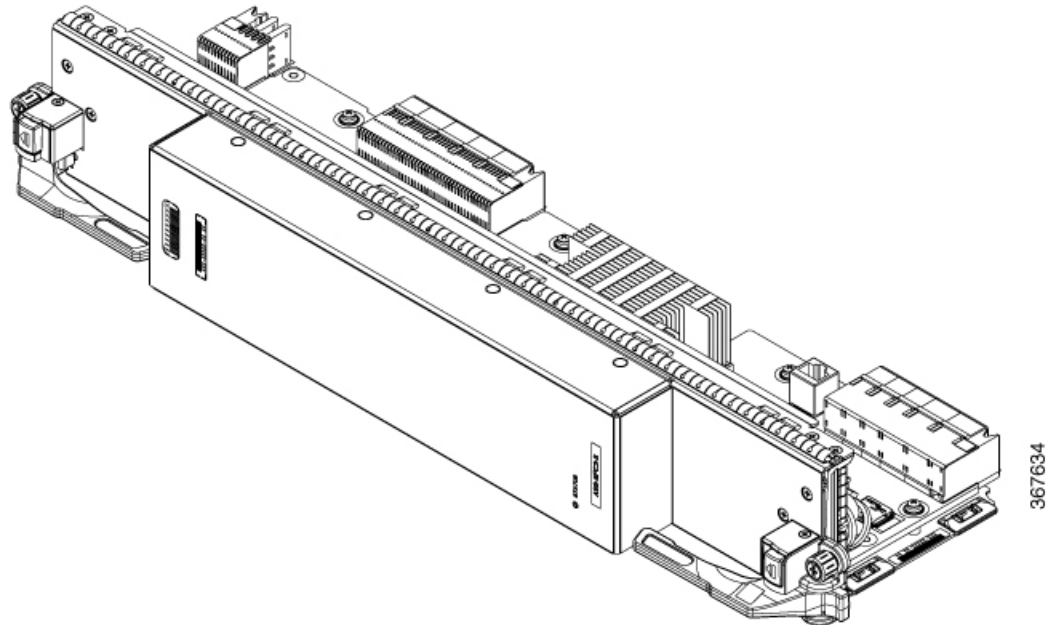
Figure 37: SFC-T Card



The following figure shows the front panel of the FC card. The front panel has a status LED, ejector levers, ejector lever release buttons, and mounting screws. The FC2/A99-SFC3 and SFC-T /A99-SFC3-Tcard is similar.

Figure 38: FC Card Front Panel

The following figure shows the front panel of the A99-SFC3-S card. The front panel has a status LED, ejector levers, ejector lever release buttons, and mounting screws.

Figure 39: A99-SFC3-S Card

FC Card Front Panel Indicator

The front panel of the FC card has one tri-color LED indicator for system information.

The following table lists the display definitions of the discrete LED on the FC card front panel.

Table 9: FC Card LED Display Definitions

Indicator (Label)	Color	Description
STATUS	Green	FC card powered on and FPGA is programmed. Note Fabric Data Link failure is not detected so LED remains green. Monitor CLI messages for status.
	Red	Fault or malfunction in FC card power up or FPGA programming. Note Once any ejector lever release button is pushed in, the FC card must be physically removed and reinserted (OIR) to restart the FC card. During this time before the FC card is restarted, the LED is red.
	Amber	FC card powered on but fabric not active.
	Off (Default after reset)	FC card powered off via CLI.

FC Card Ejector Levers

Ejector levers are provided for inserting and removing the FC cards from the backplane connectors. The insertion and removal force of the card ejector levers is about 16 lbs (7.27 kg). To release the ejector levers, push in the ejector lever release buttons.



Note Once any ejector lever release button is pushed in, the FC card must be physically removed and reinserted (OIR) to restart the FC card.

Ethernet Line Cards

For line card installation information, see the [Cisco ASR 9000 Series Aggregation Services Routers Ethernet Line Card Installation Guide](#).

In addition, a SPA Interface Processor (SIP) and Shared Port Adapters (SPA) are supported on the Cisco ASR 9000 Series Routers. For information about these components, see the [Cisco ASR 9000 Aggregation Services Router SIP and SPA Hardware Installation Guide](#).

Line Card Serviceability

Line cards can be inserted or removed when adjacent (cabled) RSP or line cards are installed.

Line Card Ejector Levers

Ejector levers are provided for inserting and removing line cards from the backplane connectors. Insertion and removal force of the card ejector levers is about 16 lbs (7.27 kg).

Power System

The Cisco ASR 9000 Series Routers can be powered with an AC or DC source power. The power system provides power for the cards and fan trays. Depending on the router, version 1, version 2, and version 3 power systems are supported.



Note The type (AC or DC) and version (1, 2, or 3) of the power tray (PEM) and power supply must match.

The power system is based on a distributed power architecture centered around a –54 VDC printed circuit power bus on the system backplane.

The –54 VDC system backplane power bus can be sourced from one of two options:

- AC systems—AC/DC bulk power supply tray connected to the user 200 to 240 VAC +/- 10 percent (180 to 264 VAC) source
- DC systems—DC/DC bulk power supply tray connected to the user Central Office DC battery source –48 VDC/–60 VDC (–54 VDC nominal)

DC output power from each power tray is connected to the router by two power blades that mate to the power bus on the backplane. The system backplane distributes DC power through connectors on the backplane to each card and the fan trays. Each card has on-board DC–DC converters to convert the –54 VDC from the distribution bus voltage to the voltages required by each particular card.

AC and DC Power Modules

Each AC or DC power tray houses up to four power modules. The power trays drive a single output bus that delivers –54 V to all cards and fan trays that are plugged into the backplane.



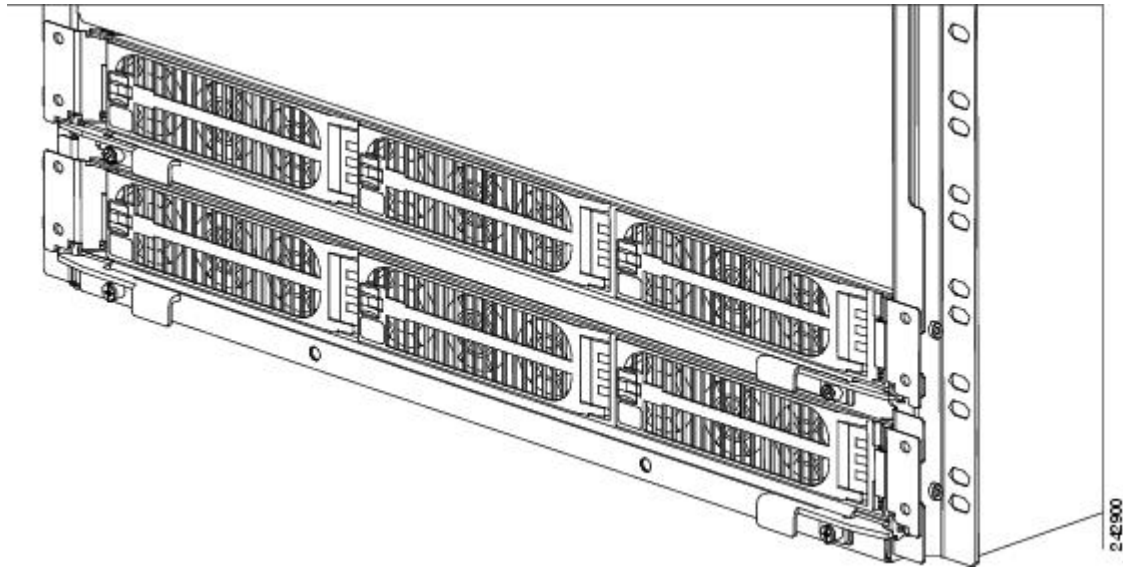
Caution While performing a FPD upgrade of the ASR 9000 6kW AC Power Module Version 3 (PWR-6KW-AC-V3) and the ASR 9000 4.4kW DC Power Module Version 3 (PWR-4.4KW-DC-V3), ensure that you connect both input power cords to the power supply. If the power cords are not connected, the FPD upgrade for the power module will fail.

Cisco ASR 9010 Router Power Modules

The following figure shows a front view of six version 1 power modules in the Cisco ASR 9010 Router.

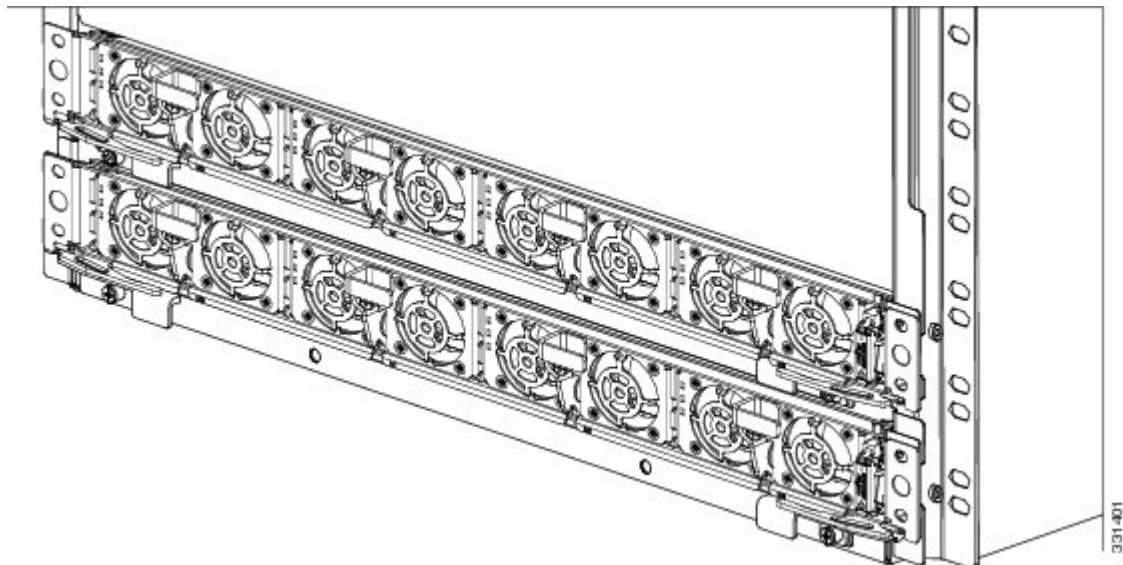
The AC power trays in the Cisco ASR 9010 Router provide N+N redundancy. The DC power trays provide N+1 redundancy.

Figure 40: Front System View of Power Trays—Cisco ASR 9010 Router with Version 1 Power Trays



The following figure shows a front view of eight version 2 power modules in the Cisco ASR 9010 Router. The front view of eight version 3 DC power modules in the Cisco ASR 9010 Router is similar.

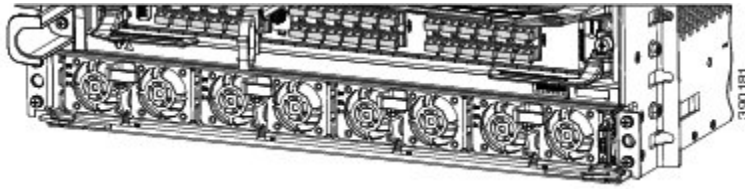
Figure 41: Front System View of Power Trays—Cisco ASR 9010 Router with Version 2 Power Trays



Cisco ASR 9904 Router Power Modules

The AC and DC power trays in the Cisco ASR 9006 Router and Cisco ASR 9904 Router provide N+1 redundancy.

The Cisco ASR 9006 Router supports one power tray with up to three version 1 power modules or four version 2 power modules. The Cisco ASR 9904 Router supports one power tray with up to four version 2.



Cisco ASR 9906 Router Power Modules

The AC and DC power trays in the Cisco ASR 9906 Router provide N+1 redundancy.

The Cisco ASR 9906 Router supports one power tray with up to three version 3 AC power modules or four version 3 DC power modules.

Figure 42: Front System View of Power Tray—Cisco ASR 9906 Router with Version 3 AC Power Tray

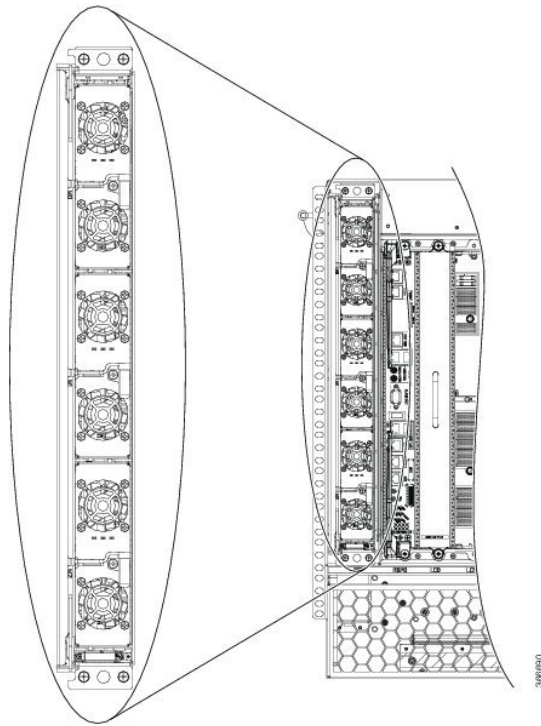
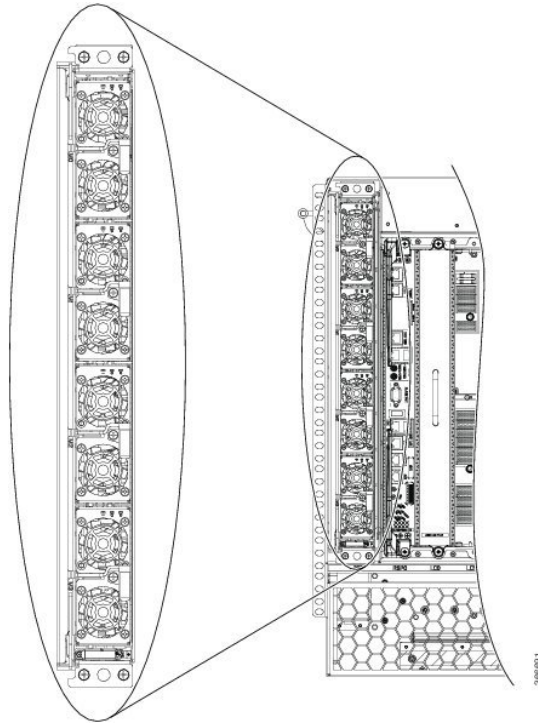


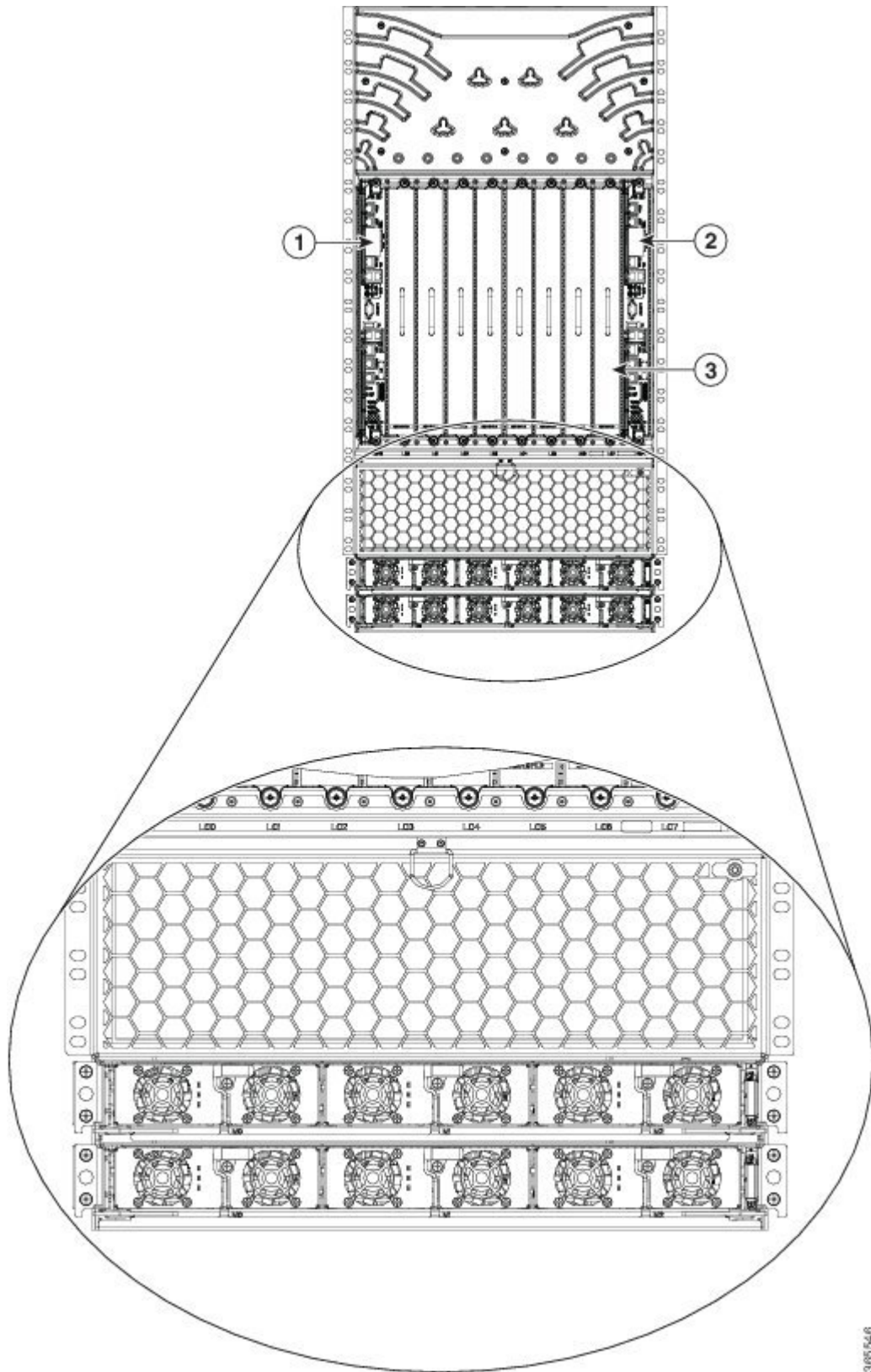
Figure 43: Front System View of Power Tray—Cisco ASR 9906 Router with Version 3 DC Power Tray



Cisco ASR 9910 Router Power Modules

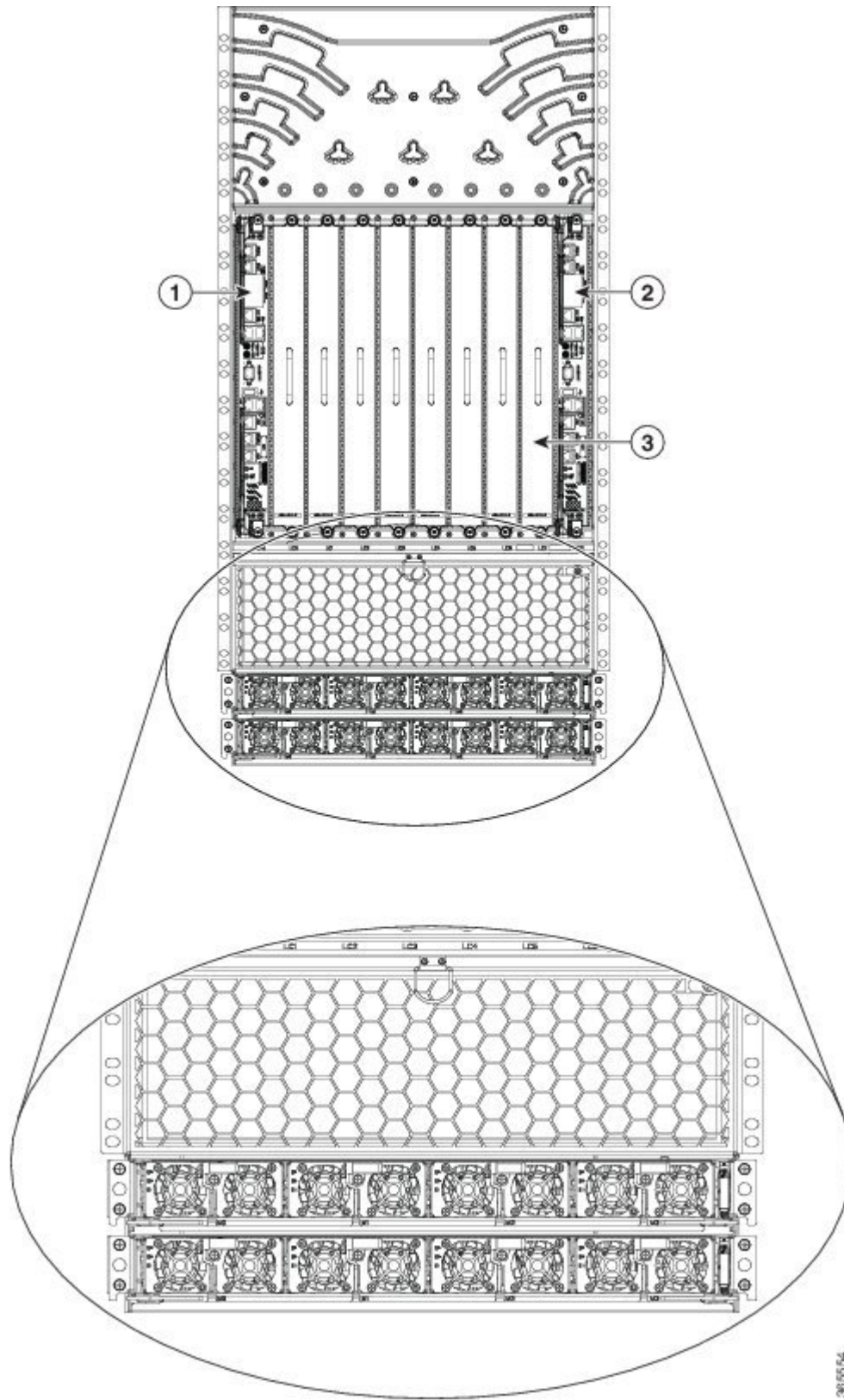
The power trays in the Cisco ASR 9910 Router provide 4+2 redundancy. The DC power trays provide 5+3 redundancy. The Cisco ASR 9910 Router supports two power tray with up to six version 3 AC power modules or up to eight version 3 DC power modules.

Figure 44: Front System View of Power Trays—Cisco ASR 9910 Router with Version 3 AC Power Trays



365546

Figure 45: Front System View of Power Trays—Cisco ASR 9910 Router with Version 3 DC Power Trays



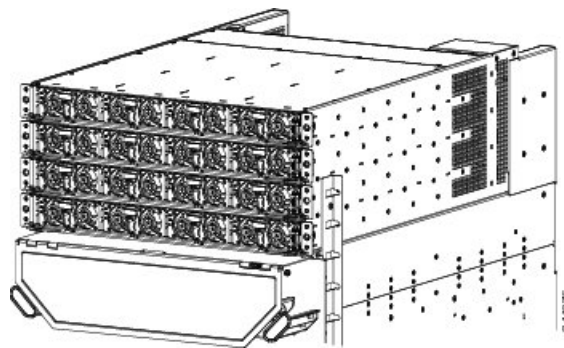
Cisco ASR 9922 Router Power Modules

The power trays in the Cisco ASR 9922 Router provide N+N redundancy. The DC power trays provide N+1 redundancy.

- To operate the Cisco ASR 9922 Router on AC power:
 - Four power trays should be installed, each with up to four version 2 power modules or up to three version 3 power modules.
 - Each version 2 power module is fed by a single-phase 220-V 20-A circuit. Each version 3 power module is fed by two single-phase 220-V 20-A circuits.
 - Eight version 2 or six version 3 power modules are enough to power a fully-populated chassis.
 - Sixteen version 2 or twelve version 3 power modules are required for N+N redundancy. Fewer power modules can be used if the chassis is populated with fewer line cards.

The following figure shows an example of version 2 power modules installed in the Cisco ASR 9922 Router.

Figure 46: Front System View of Power Trays —Cisco ASR 9922 Router with Version 2 Power Trays



To operate the Cisco ASR 9922 Router on DC power:

- Four DC power trays should be installed, each with up to four version 2 or version 3 power modules.
- Each version 2 power module is fed by a single-phase 220-V 20-A circuit. Each version 3 power module is fed by two single-phase 220-V 20-A circuits.
- Fifteen power modules are enough to power a fully-populated chassis.
- Sixteen power modules are required for N+1 redundancy. Fewer power modules can be used if the chassis is populated with fewer line cards.

Cisco ASR 9912 Router Power Modules

The power trays in the Cisco ASR 9922 Router provide N+N redundancy. The DC power trays provide N+1 redundancy.

To operate the Cisco ASR 9912 Router on AC power:

- Three power trays must be installed, each with up to four version 2 power modules or up to three version 3 power modules.
- Each version 2 power module is fed by a single-phase 220-V 20-A circuit. Each version 3 power module is fed by two single-phase 220-V 20-A circuits.
- Six power modules are enough to power a fully-populated chassis.
- Twelve version 2 or nine version 3 power modules are required for N+N redundancy. Fewer power modules can be used if the chassis is populated with fewer line cards.

To operate the Cisco ASR 9912 Router on DC power:

- Three DC power trays must be installed, each with up to four version 2 or version 3 power modules
- Eleven power modules are enough to power a fully-populated chassis.
- Twelve power modules are required for N+1 redundancy. Fewer power modules can be used if the chassis is populated with fewer line cards.

Cooling System

The Cisco ASR 9000 Series chassis is cooled by removable fan trays. The fan trays provide full redundancy and maintain required cooling if a single fan failure should occur.

The Cisco ASR 9000 Series Routers are configured in such a way that a fan failure or its subsequent replacement does not cause a significant outage. During either a fan replacement or a fan failure, the airflow is maintained and no outage occurs. Also, the fan trays are hot swappable so that no outage occurs during replacement.



Note Due to air leakage, the chassis should not be operated with any of the fan trays completely missing. The system shuts itself off if all fan trays are removed and the system crosses the Shutdown Temperature Threshold (STT). Replace any missing fan tray within five minutes. Any fan tray replacement should be performed when the chassis is back to room temperature.

The following figure shows the fan tray locations and cooling redundancy information for the Cisco ASR 9000 Series Routers.

Table 10: Cisco ASR 9000 Series Routers Fan Tray Locations and Redundancy Information

Router	Fan Tray Locations
Cisco ASR 9010 Router	<p>The chassis contains two fan trays for redundancy (Cisco ASR 9010 Router Fan Trays). The fan trays are located one above the other below the card cage and are equipped with handles for easy removal. The chassis has a front-to-rear cooling path (Figure 71: Cisco ASR 9010 Router Chassis Cooling Path—Side View). The inlet is at the bottom front of the chassis, and the exhaust is at the upper rear.</p> <p>Each fan tray has 12 fans arranged in three groups of four fans each. Two fans of each group share a fan controller. The power supplied to the fan controller is 1:3 protected. A single fan failure has no impact on air flow because the other 11 fans will compensate for it. If the fan controller fails, there is a possibility of up to two fans failing; however, the design always has two fans operating in a row (three rows of fans) to compensate for the air speed.</p>
Cisco ASR 9006 Router	<p>The chassis contains two fan trays for redundancy (Figure 78: Cisco ASR 9006 Router Fan Tray). The fan trays are located at the top left of the chassis. They are covered by a fan tray door hinged at the bottom, which must be opened before removing the fan trays. The chassis has a side-to-top-to-rear cooling path (Figure 72: Cisco ASR 9006 Router Chassis Cooling Path). The inlet is at the right side of the chassis, and the exhaust is at the upper rear.</p> <p>Each fan tray has six fans arranged in three groups of two fans each. The two fans in a group share a fan controller. The power supplied to the fan controller is 1:3 protected. A single fan failure has no impact on air flow because the other five fans will compensate for it. If the fan controller fails, there is a possibility of up to two fans failing; however, the design always has two fans operating to compensate for the air speed.</p>

Router	Fan Tray Locations
Cisco ASR 9904 Router	<p>The chassis contains a single fan tray. The fan tray is located at the left side of the chassis and is accessible from the rear (Cisco ASR 9904 Router Fan Tray, on page 98). The chassis has a side-to-side cooling path (Figure 73: Cisco ASR 9904 Router Chassis Cooling Path, on page 94). The inlet is at the right side of the chassis, and the exhaust is at the left side.</p> <p>The fan tray has 12 fans. Every two fans share a fan controller. The power supplied to the fan controller is 1:1 protected. A single fan failure has no impact on air flow because the other eleven fans will compensate for it. I.</p> <p>If the router is installed in a 2-post 23-inch rack, air flow is circulated front-to-back. An optional air baffle accessory kit (ASR-9904-BAFFLE=) is available for mounting the router chassis in this configuration. For air baffle installation information, see the Cisco ASR 9000 Series Aggregation Services Router Hardware Installation Guide.</p>
Cisco ASR 9906 Router	<p>The chassis contains two fan trays for redundancy. The fan trays are located at the top right of the chassis. They are covered by a fan tray door hinged at the left, which must be opened before removing the fan trays. The chassis has a front-to-top-to-rear cooling path (Figure 74: Cisco ASR 9906 Router Chassis Cooling Path, on page 94). The inlet is at the bottom of the chassis, and the exhaust is at the lower rear.</p> <p>Each fan tray has seven fans. The two fans in a group share a fan controller. The power supplied to the fan controller is 1:3 protected. A single fan failure has no impact on air flow because the other six fans will compensate for it. If the fan controller fails, there is a possibility of up to two fans failing; however, the design always has two fans operating to compensate for the air speed.</p>
Cisco ASR 9910 Router	<p>The chassis contains two fan trays for redundancy. The two fan trays are located at the top of the chassis below the exhaust and are equipped with handles for easy removal. The chassis has a front-to-rear cooling path (Figure 75: Cisco ASR 9910 Router Chassis Cooling Path—Side View , on page 95). The inlet is at the bottom front of the chassis, and the exhaust is at the upper rear.</p> <p>Each fan tray has 12 fans arranged in three groups of four fans each. Two fans of each group share a fan controller. The power supplied to the fan controller is 1:3 protected. A single fan failure has no impact on air flow because the other 11 fans will compensate for it. If the fan controller fails, there is a possibility of up to two fans failing; however, the design always has two fans operating in a row (three rows of fans) to compensate for the air speed.</p>
Cisco ASR 9912 Router	<p>The chassis contains two fan trays for redundancy (Figure 81: Cisco ASR 9922 Router and Cisco ASR 9912 Router Fan Tray). The fan trays are located above the line card cage. The chassis has a front-to-rear cooling path (Figure 77: Cisco ASR 9912 Router Chassis Cooling Path—Side View , on page 97). The inlet is at the front of the RP/FC card cage, and the exhaust is at the upper rear.</p> <p>Each fan tray holds 12 axial fans and includes a controller that reduces the speed of the fans when the chassis temperature is within limits, thereby reducing the generation of acoustic noise. The fan controller also senses and reports individual fan failures.</p> <p>The power supplied to the fan controller is 1:3 protected. A single fan failure has no impact on air flow because the other 11 fans will compensate for it. If the fan controller fails, there is a possibility of up to two fans failing; however, the design always has two fans operating in a row (three rows of fans) to compensate for the air speed.</p>

Router	Fan Tray Locations
Cisco ASR 9922 Router	<p>The chassis contains four fan trays (Figure 81: Cisco ASR 9922 Router and Cisco ASR 9912 Router Fan Tray). Two top fan trays are located between the top and middle cages, whereas the two bottom fan trays are located between the middle and bottom cages. The two bottom fan trays are inserted upside down compared to the two top fan trays. The cages of the chassis have a front-to-rear cooling path (Figure 76: Cisco ASR 9922 Router Chassis Cooling Path—Side View, on page 96). The inlet is at the front of the middle cage, and the exhaust is at the upper and lower rear.</p> <p>The fan tray has an LED indicator to indicate fan tray status. If a fan fails, it is possible to swap a single fan tray assembly while the system is operational. Fan tray removal does not require removal of any cables</p>

Management and Configuration

The Cisco ASR 9000 Series Routers run IOS XR software and use the system manageability architecture of that operating system. The system management interfaces consist of the following three protocols running on the Cisco ASR 9000 Series Routers:

- CLI—Command-line interface
- XML—Extensible Markup Language
- SNMP—Simple Network Management Protocol

By default, only CLI on the console is enabled.

Craft Works Interface (CWI), a graphical craft tool for performance monitoring, is embedded with the Cisco IOS XR software and can be downloaded through the HTTP protocol. You can use CWI to edit the router configuration file, open Telnet/SSH application windows, and create user-defined applications.



CHAPTER 2

Functional Description

This chapter provides a functional description of the Cisco ASR 9000 Series Router, Route Switch Processor (RSP) card, Route Processor (RP) card, Switch Fabric Controller (FC) card, Ethernet line cards, power and cooling systems, and subsystems such as management, configuration, alarms, and monitoring.

- [Router Operation, on page 71](#)
- [Route Switch Processor Card, on page 75](#)
- [Route Processor Card, on page 76](#)
- [Fabric Controller Card, on page 82](#)
- [Ethernet Line Cards, on page 82](#)
- [Modular Line Cards, on page 83](#)
- [Power System Functional Description, on page 84](#)
- [Cooling System Functional Description, on page 92](#)
- [System Management and Configuration, on page 109](#)
- [Online Diagnostics, on page 110](#)

Router Operation

The ASR 9000 Series Routers are fully distributed routers that use a switch fabric to interconnect a series of chassis slots, each of which can hold one of several types of line cards. Each line card in the Cisco ASR 9000 Series has integrated I/O and forwarding engines, plus sufficient control plane resources to manage line card resources. Two slots in the chassis are reserved for RSP/RP cards to provide a single point of contact for chassis provisioning and management.

[Figure 47: Cisco ASR 9010 Router, Cisco ASR 9006 Router, Cisco ASR 9904 Router and Cisco ASR 9910 Router Platform Architecture, on page 72](#) shows the platform architecture of the Cisco ASR 9010 Router, Cisco ASR 9006 Router, Cisco ASR 9904 Router and Cisco ASR 9910 Router.

[Figure 48: Cisco ASR 9922 Router and Cisco ASR 9912 Router Platform Architecture, on page 72](#) show the platform architecture of the Cisco ASR 9922 Router and Cisco ASR 9912 Router.

[Figure 49: Major Components in the Cisco ASR 9000 Series Routers Line Cards, on page 73](#) shows the major components in the Cisco ASR 9000 Series line cards. [Figure 50: Additional System Components in the Cisco ASR 9000 Series Routers Line Cards, on page 74](#) shows additional components for the Cisco ASR 9000 Series line cards.

[Figure 51: Major System Components and Interconnections in the Cisco ASR 9922 Router, on page 75](#) shows the major system components and interconnections for the Cisco ASR 9922 Router. The switch fabric for the

Cisco ASR 9912 Router is the same except that the router supports up to 10 line cards. The switch fabric card (ASR-9912-SFC110) for the Cisco ASR 9912 Router, is the only FC that has a single fabric ASIC.

Figure 47: Cisco ASR 9010 Router, Cisco ASR 9006 Router, Cisco ASR 9904 Router and Cisco ASR 9910 Router Platform Architecture

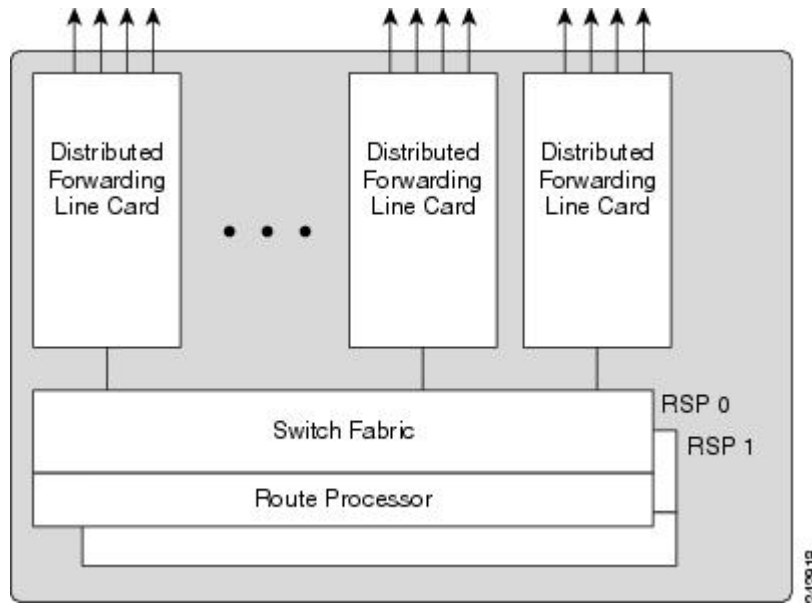


Figure 48: Cisco ASR 9922 Router and Cisco ASR 9912 Router Platform Architecture

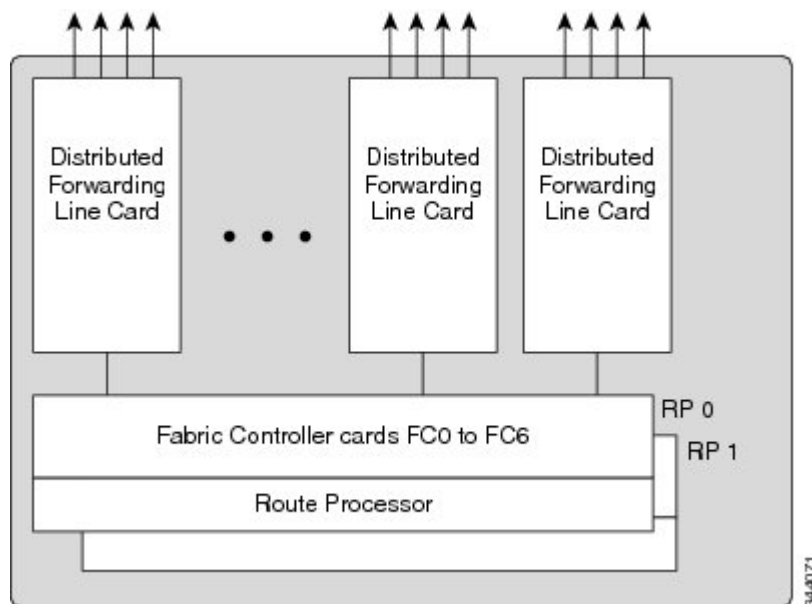
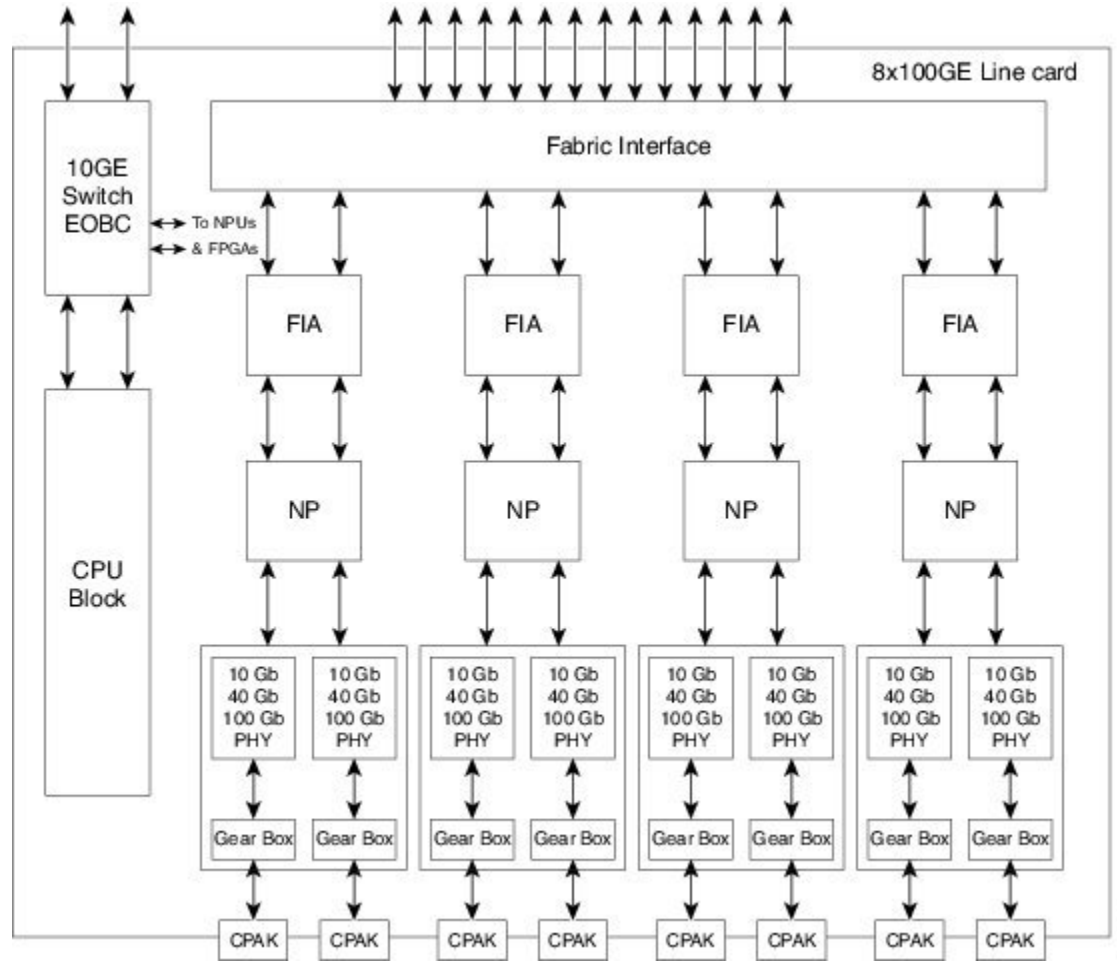


Figure 49: Major Components in the Cisco ASR 9000 Series Routers Line Cards



384-329

Figure 50: Additional System Components in the Cisco ASR 9000 Series Routers Line Cards

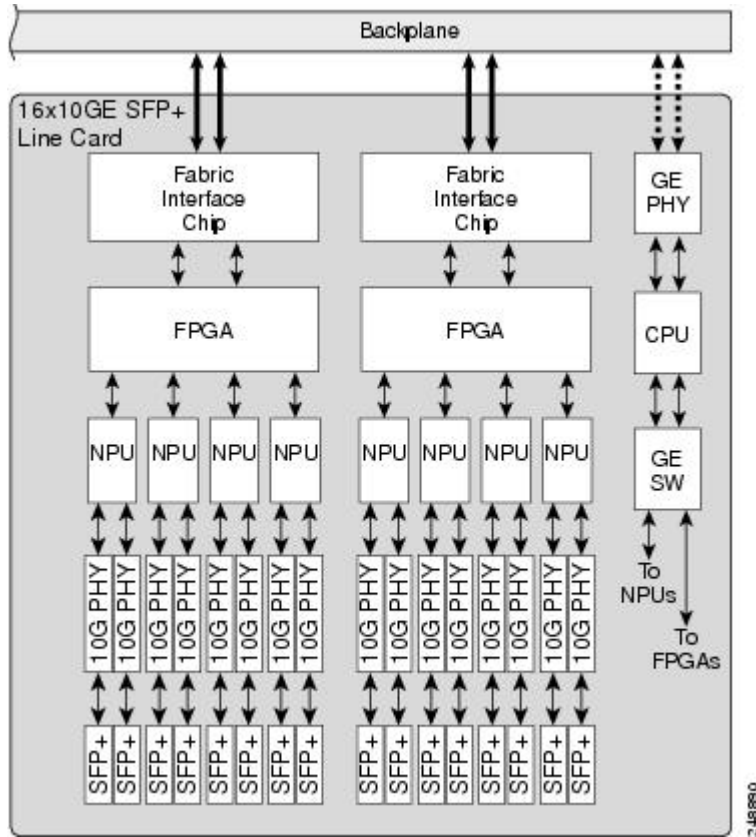
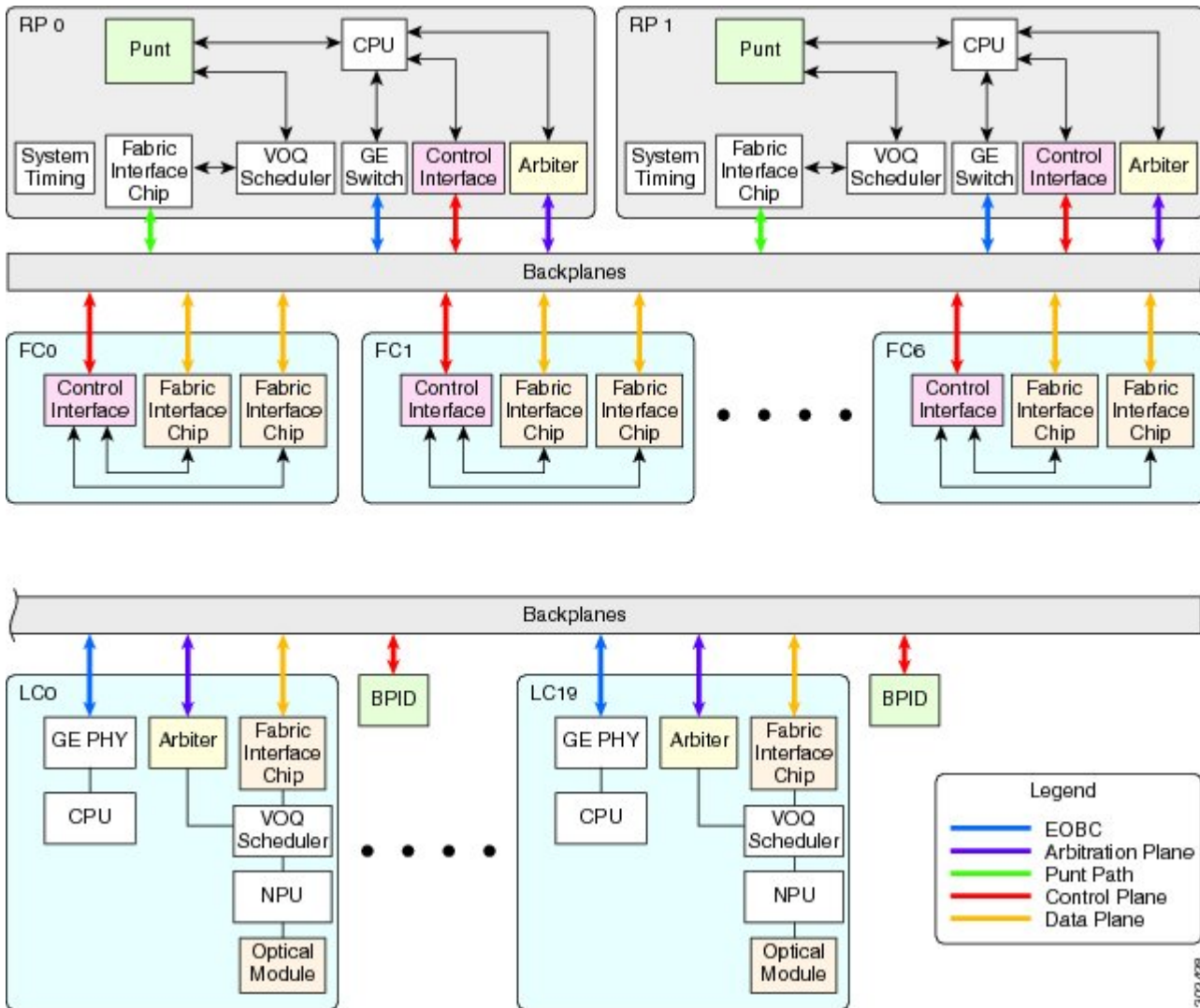


Figure 51: Major System Components and Interconnections in the Cisco ASR 9922 Router



Route Switch Processor Card

The RSP card is the main control and switch fabric element in the Cisco ASR 9010 Router, Cisco ASR 9006 Router, Cisco ASR 9904 Router, Cisco and ASR 9906 Router. The Cisco ASR 9910 Router has Fabric Cards (FC) that acts as the main control element. The RSP card provides system control, packet switching, and timing control for the system. To provide redundancy, there can be two RSP cards in the system, one as the active control RSP and the other as the standby RSP. The standby RSP takes over all control functions if the active RSP fails.

The RSP-440 (second generation) and RSP-880 (third generation) router processor cards support the next generation of Cisco ASR 9000 Series line cards, and have increased bandwidth, memory, and processing capabilities.

RSP-440 Lite is a cost optimized version of the RSP-440 that offers the same 160 Gbps capacity which is license upgradeable to the 400Gbps capacity.

RSP880-LT is a cost optimized version of the RSP-880 that offers the same 400Gbps capacity.

RSP5 is the next-generation system processor for the Cisco ASR 9000 Series Routers. It supports high-density 100 Gigabit Ethernet line cards and provides backward compatibility with the Cisco ASR 9000 Series third generation family of line cards.

For detailed information about RSP cards, see [Route Switch Processor and Route Processor Cards](#).

Route Processor Card

The RP card is the main control element in the Cisco ASR 9922 Router and Cisco ASR 9912 Router chassis. The switch fabric element has been moved to the FC cards. The RP card provides system control, packet switching, and timing control for the system. To provide redundancy, there are two RP cards in the system, one as the active control RP and the other as the standby RP. The standby RP takes over all control functions should the active RP fail.

The RP2/RP3 card has more processing power than the previous RP card. It also doubles the amount of storage and supported memory as well as the memory bandwidth. This provides the path to scale the number of routes up in this generation. In addition, the internal control plane bandwidth has been scaled up to allow better control of the linecards as the network bandwidth increases.

For detailed information about RP cards, see [Route Switch Processor and Route Processor Cards](#).

Functional Description

In the Cisco ASR 9922 Router and Cisco ASR 9912 Router, the route processor functions are on the RP card, whereas the switch fabric is on the FC card. The RSP/RP card also provides shared resources for backplane Ethernet, timing, and chassis control. Redundant RSP/RP cards provide the central point of control for chassis provisioning, management, and data-plane switching.

Switch Fabric

The switch fabric and route processor functions are combined on a single RSP card in the Cisco ASR 9010 Router, Cisco ASR 9006 Router, Cisco ASR 9904 Router and Cisco ASR 9910 Router. The switch fabric portion of the RSP card links the line cards together.

The switch fabric is configured as a single stage of switching with multiple parallel planes. The fabric is responsible for getting packets from one line card to another, but has no packet processing capabilities. Each fabric plane is a single-stage, non-blocking, packet-based, store-and-forward switch. To manage fabric congestion, the RSP card also provides centralized Virtual Output Queue (VOQ) arbitration.

The switch fabric is 1+1 redundant, with one copy of the fabric on each redundant RSP card. Each RSP card carries enough switching capacity to meet the router throughput specifications, allowing for full redundancy.

- In systems with the RSP card, the switch fabric delivers up to 80-Gbps per line card slot.
- In systems with the RSP-440 card or RSP-440 Lite card, the switch fabric delivers up to 220-Gbps per line card slot in redundant 1+1 mode and up to 440-Gbps per line card slot in non-redundant mode (two active RSPs).

- In systems with the RSP4-S card the switch fabric delivers up to 220-Gbps per line card slot in redundant 1+1 mode and up to 440-Gbps per line card slot in non-redundant mode (two active RSPs).
- In systems with the RSP-880 card or A9K-RSP880-LT card, the switch fabric delivers up to 440-Gbps per line card slot in redundant 1+1 mode and up to 880-Gbps per line card slot in non-redundant mode (two active RSPs).

-

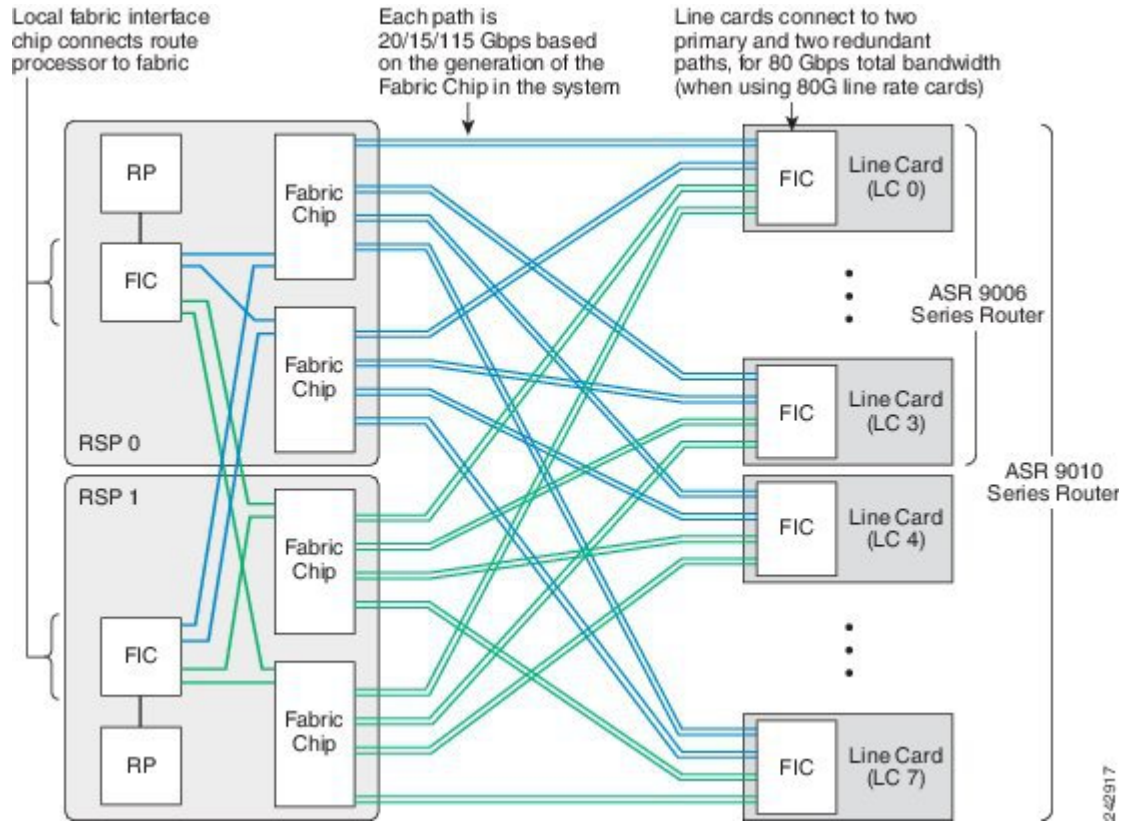
In the Cisco ASR 9922 Router and Cisco ASR 9912 Router, the switch fabric resides on dedicated line cards that connect to the backplanes alongside the RP cards.

- For first and second generation line cards, the Cisco ASR 9922 Router and Cisco ASR 9912 Router support up to five FCs in the chassis. Each FC card delivers 110G per slot. For example, when five FCs are installed in the chassis, the switch fabric is considered 4+1 redundant (one card in standby mode and four cards active), thereby delivering 440Gbps per line card slot. In non-redundant mode, the switch fabric delivers 550-Gbps per line card slot.
- For third generation line cards, the Cisco ASR 9922 Router and Cisco ASR 9912 Router support up to seven FCs in the chassis. Each FC card carries 230G per slot. For example, when five FCs are installed in the chassis, the switch fabric is 4+1 redundant (one card in standby mode and four cards active), thereby delivering 920-Gbps per slot (230x4). In non-redundant mode, the switch fabric delivers 1.15 Tbps per line card.

When all seven FC cards are installed in the chassis, the switch fabric is 6+1 redundant (one card in standby mode and six cards in active), and is capable of delivering up to 1.38 Tbps per slot (230x6).

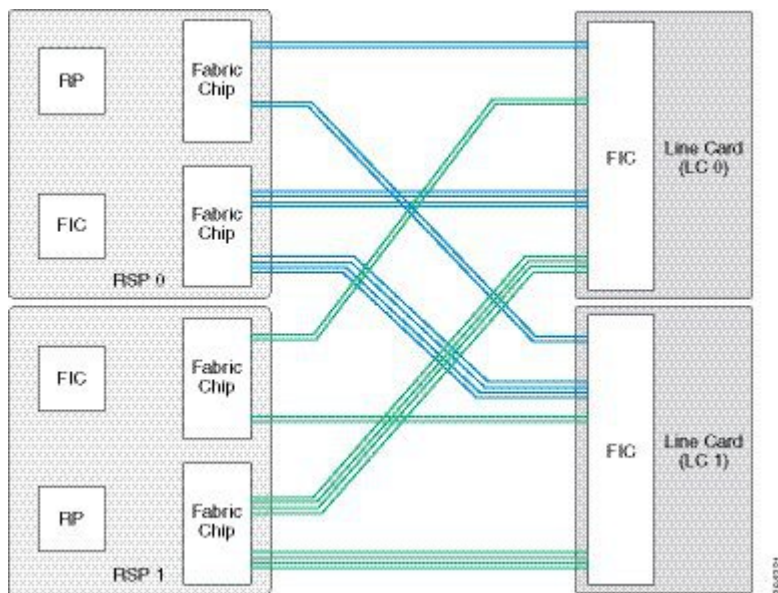
The following figure shows the switch fabric interconnections for the Cisco ASR 9006 Router and Cisco ASR 9010 Router.

Figure 52: Switch Fabric Interconnections—Cisco ASR 9006 Router and Cisco ASR 9010 Router



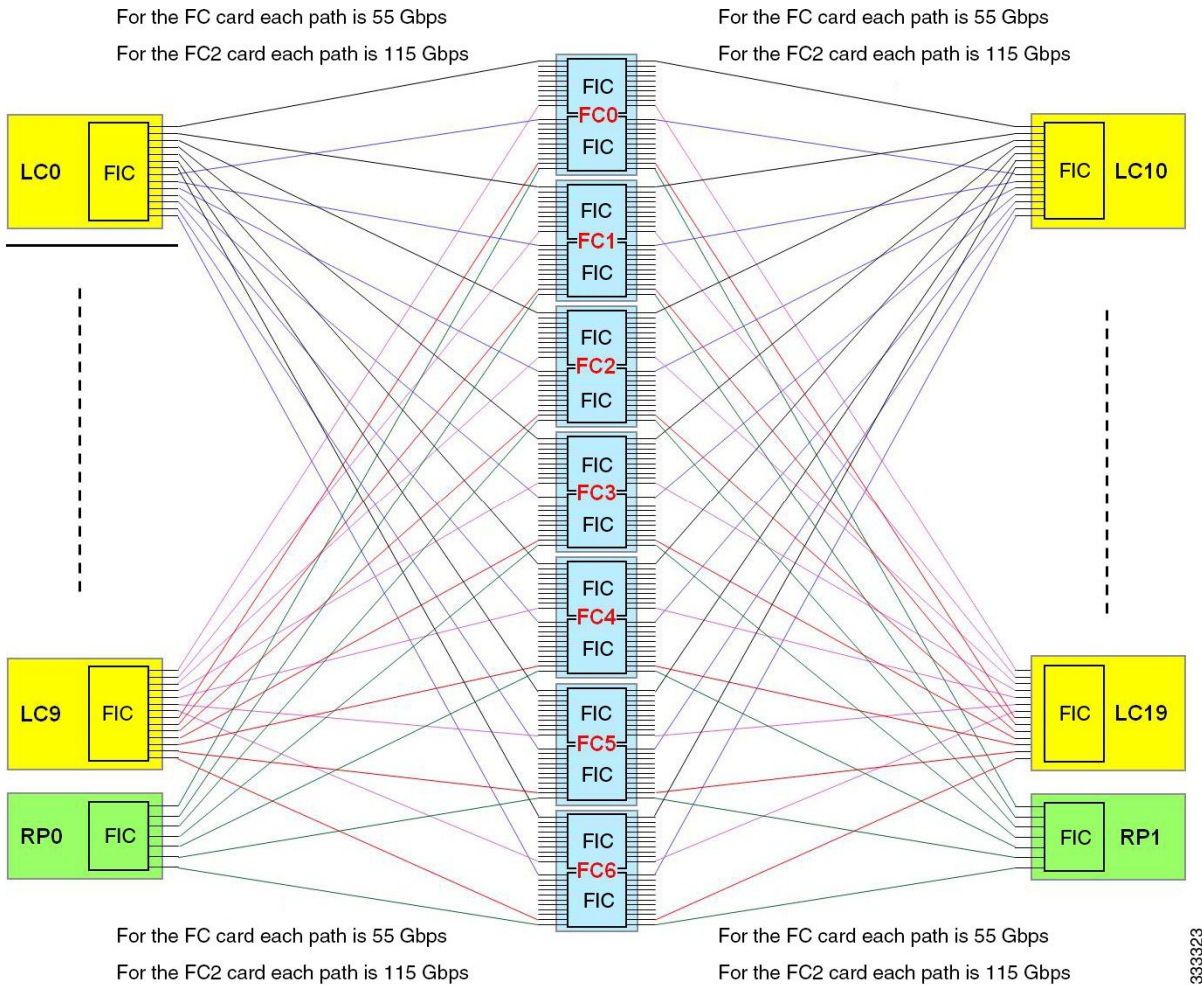
The following figure shows the switch fabric interconnections for the Cisco ASR 9904 Router.

Figure 53: Switch Fabric Interconnections—Cisco ASR 9904 Router



The following figure shows the switch fabric interconnections for the Cisco ASR 9922 Router. The switch fabric for the Cisco ASR 9912 Router is the same except that the router supports up to ten line cards and has a single FIC instead of two FICs.

Figure 54: Switch Fabric Interconnections—Cisco ASR 9922 Router



Unicast Traffic

Unicast traffic through the switch is managed by a VOQ scheduler chip. The VOQ scheduler ensures that a buffer is available at the egress of the switch to receive a packet before the packet can be sent into the switch. This mechanism ensures that all ingress line cards have fair access to an egress card, no matter how congested that egress card may be.

The VOQ mechanism is an overlay, separate from the switch fabric itself. VOQ arbitration does not directly control the switch fabric, but ensures that traffic presented to the switch will ultimately have a place to go when it exits the switch, preventing congestion in the fabric.

The VOQ scheduler is also one-for-one redundant, with one VOQ scheduler chip on each of the two redundant RSP/RP cards.

Multicast Traffic

Multicast traffic is replicated in the switch fabric. For multicast (including unicast floods), the Cisco ASR 9000 Series Routers replicate the packet as necessary at the divergence points inside the system, so that the multicast packets can replicate efficiently without having to burden any particular path with multiple copies of the same packet.

The switch fabric has the capability to replicate multicast packets to downlink egress ports. In addition, the line cards have the capability to put multiple copies inside different tunnels or attachment circuits in a single port.

There are 64-K Fabric Multicast Groups (RSP 2-based line cards) or 128-K Fabric Multicast Groups (RSP-440 and RSP-880-based line cards) in the system, which allow the replication to go only to the downlink paths that need them, without sending all multicast traffic to every packet processor. Each multicast group in the system can be configured as to which line card and which packet processor on that card a packet is replicated to. Multicast is not arbitrated by the VOQ mechanism, but it is subject to arbitration at congestion points within the switch fabric.

Route Processor Functions

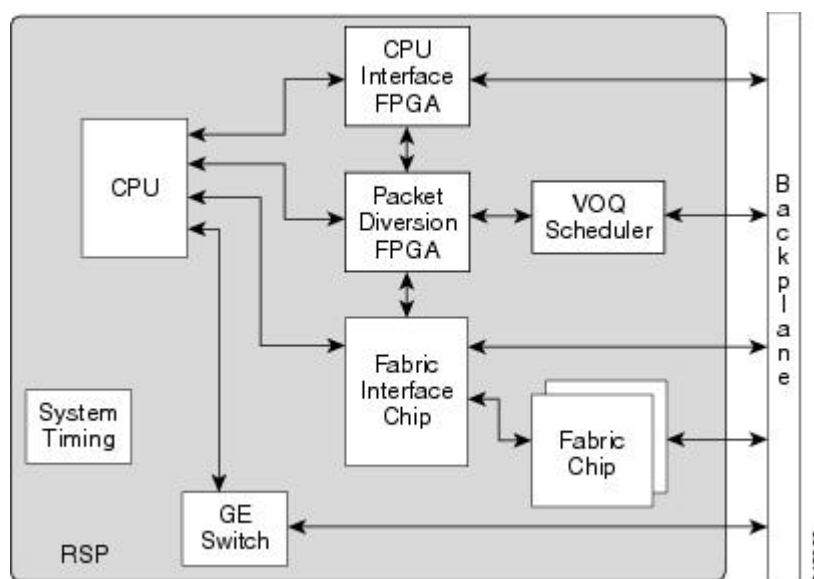
The Route Processor performs the ordinary chassis management functions. The ASR 9000 Series Routers run Cisco IOS XR software, so the Route Processor runs the centralized portions of the software for chassis control and management.

Secondary functions of the Route Processor include boot media, system timing (frequency and time of date) synchronization, precision clock synchronization, backplane Ethernet communication, and power control (through a separate CAN bus controller network).

The Route Processor communicates with other route processors and linecards over a switched Ethernet out-of-band channel (EOBC) for management and control purposes.

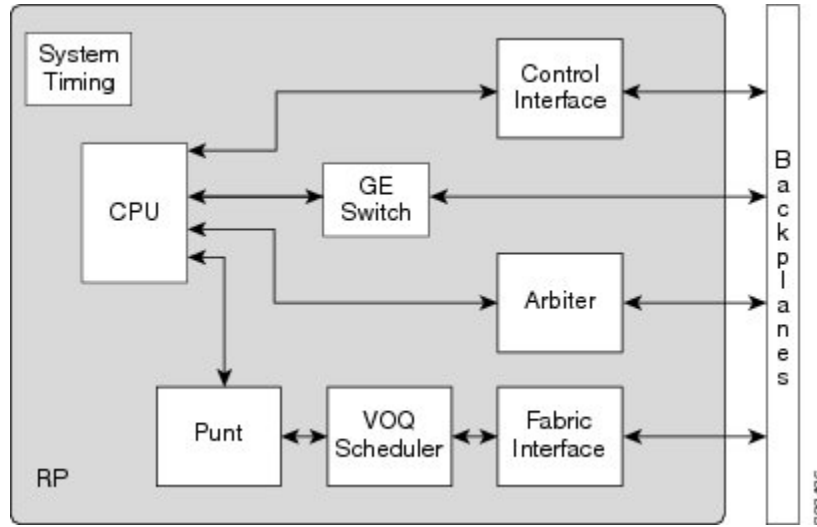
The following figure shows the route processor interconnections on the RSP.

Figure 55: Route Processor Interconnections



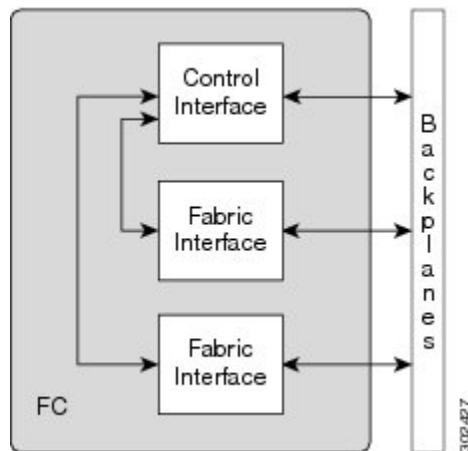
The following figure shows the component interconnections on the RP.

Figure 56: RP Component Interconnections



The following figure shows the component interconnections on the FC.

Figure 57: FC Component Interconnections



Processor-to-Processor Communication

The RSP/RP card communicates with the control processors on each line card through the Ethernet out-of-band channel (EOBC) Gigabit Ethernet switch. This path is for processor-to-processor communication, such as IPC (InterProcess Communication). The Active RSP/RP card also uses the EOBC to communicate to the Standby RSP/RP card, if installed (the RSP-880 and RP2/RP3 cards have 10GE switches used for EOBC).

Route Processor/Fabric Interconnect

The RSP card has a fabric interface chip (FIC) attached to the switch fabric and linked to the Route Processor through a Gigabit Ethernet interface through a packet diversion FPGA. This path is used for external traffic diverted to the RSP card by line card network processors.

The packet diversion FPGA has three key functions:

- Packet header translation between the header used by the fabric interface chip and the header exchanged with the Ethernet interface on the route processor.
- I/O interface protocol conversion (rate-matching) between the 20-Gbps DDR bus from the fabric interface chip and the 1-Gbps interface on the processor.
- Flow control to prevent overflow in the from-fabric buffer within the packet diversion FPGA, in case of fabric congestion.

The Route Processor communicates with the switch fabric via a FIC to process control traffic. The FIC has sufficient bandwidth to handle the control traffic and flow control in the event of fabric congestion. External traffic is diverted to the Route Processor by the line card network processors.

The RP and FC cards in the Cisco ASR 9922 Router have control interface chips and FICs attached to the backplanes that provide control plane and punt paths.

Fabric Controller Card

On the Cisco ASR 9906 Router, Cisco ASR 9910 Router, Cisco ASR 9922 Router and Cisco ASR 9912 Router, the switch fabric resides on the switch fabric cards (FCs).

The switch fabric is configured as a single stage of switching with multiple parallel planes. The switch fabric is responsible for transporting packets from one line card to another but has no packet processing capabilities. Each fabric plane is a single-stage, non-blocking, packet-based, store-and-forward switch. To manage fabric congestion, the RP provides centralized Virtual Output Queue (VOQ) arbitration.

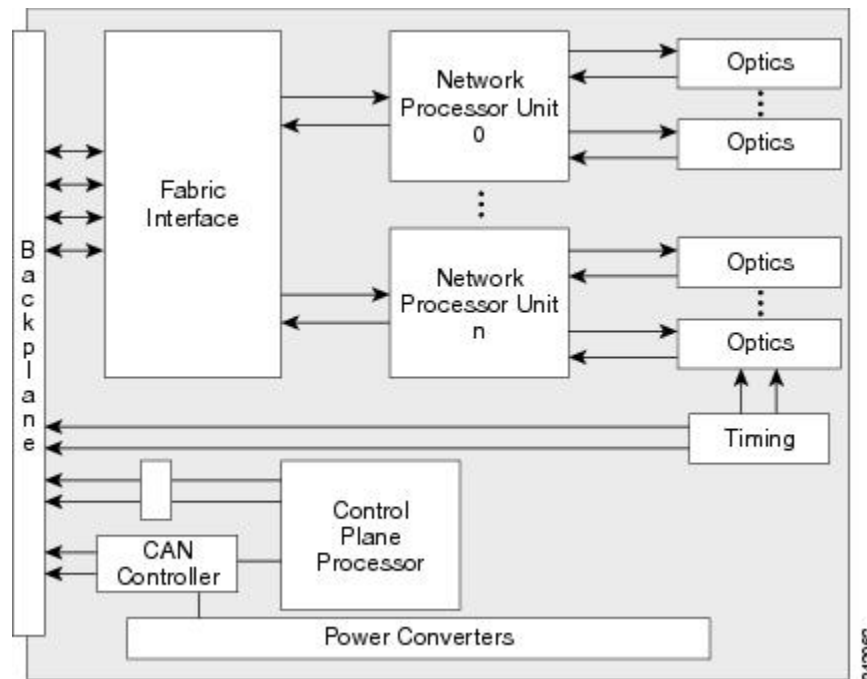
Cisco ASR 9906 and 9910: When two RSP cards and three FC cards are installed in the chassis, the switch fabric is 4+1 redundant. When two RSP cards and five FC cards are installed in the chassis, the switch fabric is 6+1 redundant. The switch fabric is fully redundant, with one copy of the fabric on each FC, and each FC carries enough switching capacity to meet the chassis throughput specifications.

Cisco ASR 9912 and 9922: When five FC cards are installed in the chassis, the switch fabric is 4+1 redundant. When all seven FC cards are installed in the chassis, the switch fabric is 6+1 redundant. The switch fabric is fully redundant, with one copy of the fabric on each FC, and each FC carries enough switching capacity to meet the chassis throughput specifications.

Ethernet Line Cards

Ethernet line cards for the Cisco ASR 9000 Series Routers provide forwarding throughput of line rate for packets as small as 64 bytes. The small form factor pluggable (SFP, SFP+, QSFP+, XFP, CFP, or CPAK) transceiver module ports are polled periodically to keep track of state changes and optical monitor values. Packet features are implemented within network processor unit (NPU) ASICs.

Figure 58: General Line Card Data Plane Block Diagram



The optics, NPU and fabric interface handles all main data and also controls data that are routed to the RSP/RP cards. The other path is to the local CPU through a switched Gigabit Ethernet link. This second link is used to process control data routed to the line card CPU or packets sent to the RSP/RP card through the fabric link. The backplane Gigabit Ethernet links, one to each RSP/RP card, are used primarily for control plane functions such as application image download, system configuration data from the IOS XR software, statistics gathering, and line card power-up and reset control.

The number of NPUs will vary depending on the number of ports. Each NPU can handle millions of packets per second, accounting for ingress and egress, with a simple configuration. The more packet processing features enabled, the lower the packets per second that can be processed in the pipeline. There is a minimum packet size of 64 bytes, and a maximum packet size of 9 KB (9216 bytes) from the external interface.

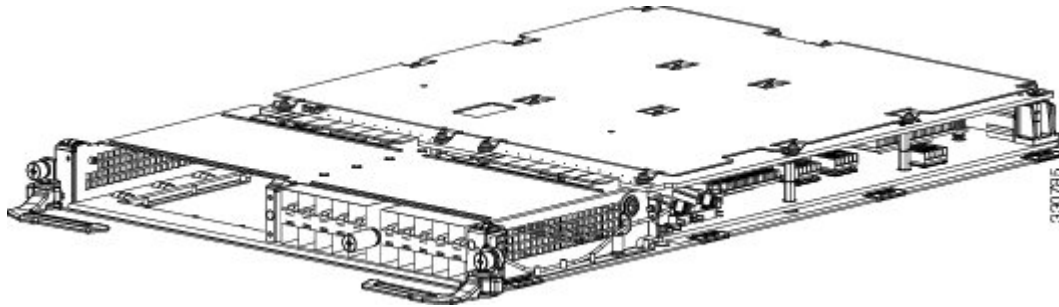
http://www.cisco.com/en/US/docs/routers/asr9000/hardware/ethernet_line_card/installation/guide/asr9kELCIGbk.html For line card installation information, see the Cisco ASR 9000 Series Aggregation Services Routers Ethernet Line Card Installation Guide .

Modular Line Cards

The modular line card is available in two network processing unit (80-Gb throughput versions). Each version is available in either a Service Edge Optimized (-SE) or Packet Transport Optimized (-TR) version. Both versions are functionally equivalent, but vary in configuration scale and buffer capacity.

The following figure shows a modular line card with a 20-port Gigabit Ethernet modular port adapter (MPA) installed in the lower bay. As shown in the figure, Bay 0 is the “upper” or “left” bay, and Bay 1 is the “lower” or “right” bay.

Figure 59: Modular Line Card



The MPA has Active/Link (A/L) LEDs visible on the front panel. Each A/L LED shows the status of both the port and the link. A green A/L LED means the state is on, the port is enabled, and the link is up. An amber A/L LED means the state is on, the port is enabled, and the link is down. An A/L LED that is off means the state is off, the port is not enabled, and the link is down.

For MPA installation information, see the Cisco ASR 9000 Series Aggregation Services Routers Ethernet Line Card Installation Guide .

Power System Functional Description

The Cisco ASR 9000 Series Routers can be powered with an AC or DC source power. The power system is based on a distributed power architecture centered around a -54 VDC printed circuit power bus on the system backplane.

The -54 VDC system backplane power bus can be sourced from one of two options:

- AC systems—AC/DC bulk power supply tray connected to the user's 200 to 240 V +/- 10 percent (180 to 264 VAC) source.
- DC systems—DC/DC bulk power supply tray connected to the user's Central Office DC battery source (-48 VDC to -60 VDC nominal).

The system backplane distributes DC power from the backplane to each card and the fan trays. Each card has on-board DC-DC converters to convert the -54 VDC from the distribution bus voltage to the voltages required by each particular card.

The power system is isolated from the central office by the transformers inside the power modules. It has single-point grounding on the -54 VDC return.

All field replaceable modules of the power system are designed for Online Insertion and Removal (OIR), so they can be installed or removed without causing interruption to system operation.



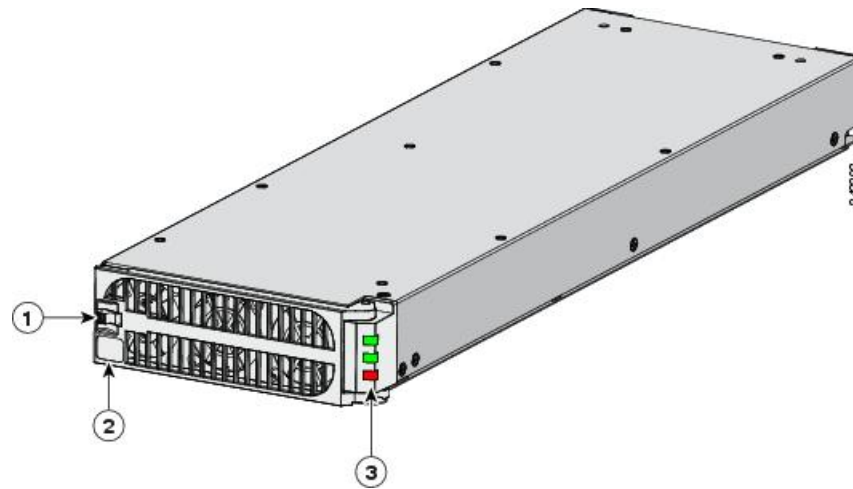
Note The Cisco ASR 9000 Series Routers have two available DC version 1 power modules, a 2100 W module and a 1500 W module. Both types of power modules can be used in a single chassis. The routers have one available DC version 2 power module (2100 W), and one available DC version 3 power module (4400 W).

Power Modules

Multiple AC/DC power modules can be installed in each AC/DC power tray.

The following figure shows the version 1 power module.

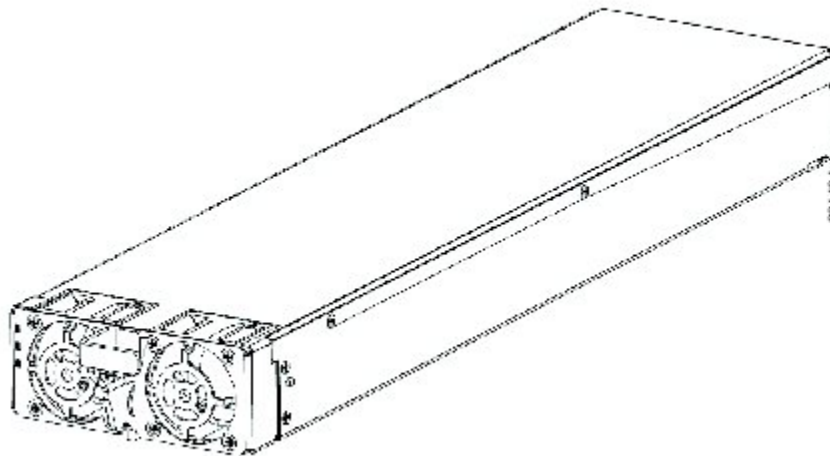
Figure 60: Version 1 Power Module



The following figure shows the version 2 power module. The version 3 power module is similar.

1. Door latch
2. Door and ejector lever
3. LED indicators

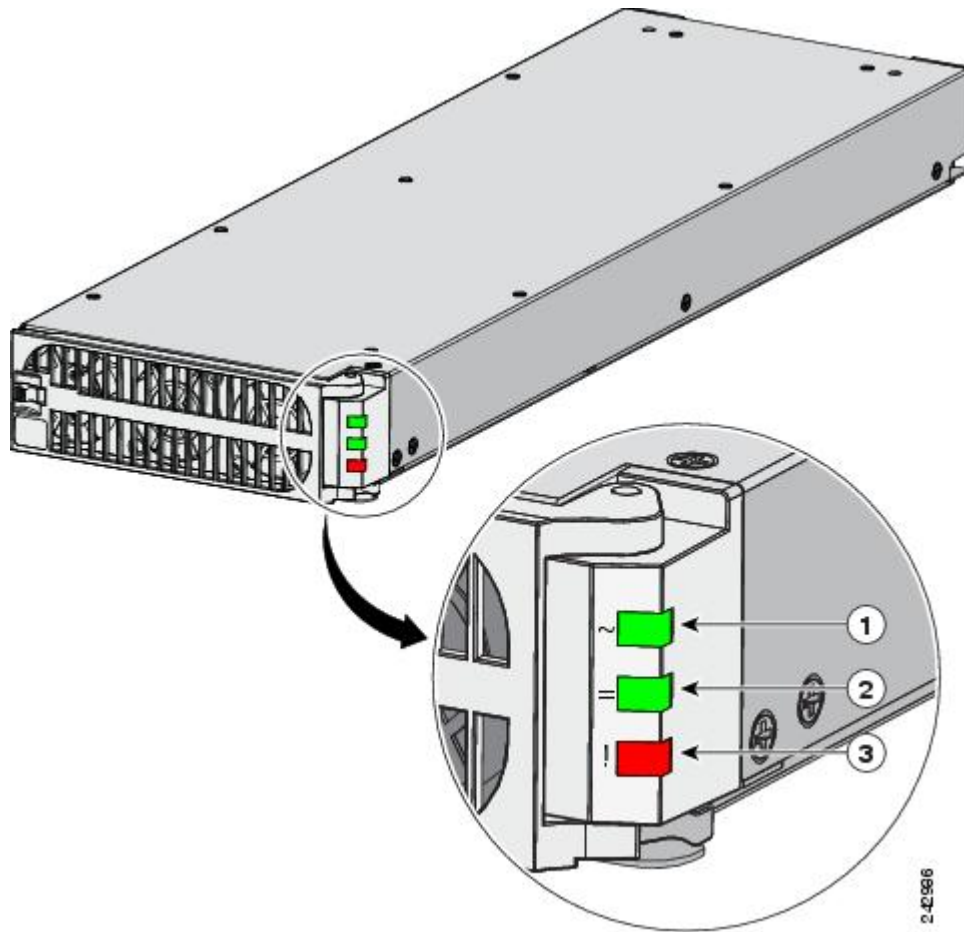
Figure 61: Version 2 Power Module



Power Module Status Indicators

The following figure shows the status indicators for the version 1 power module.

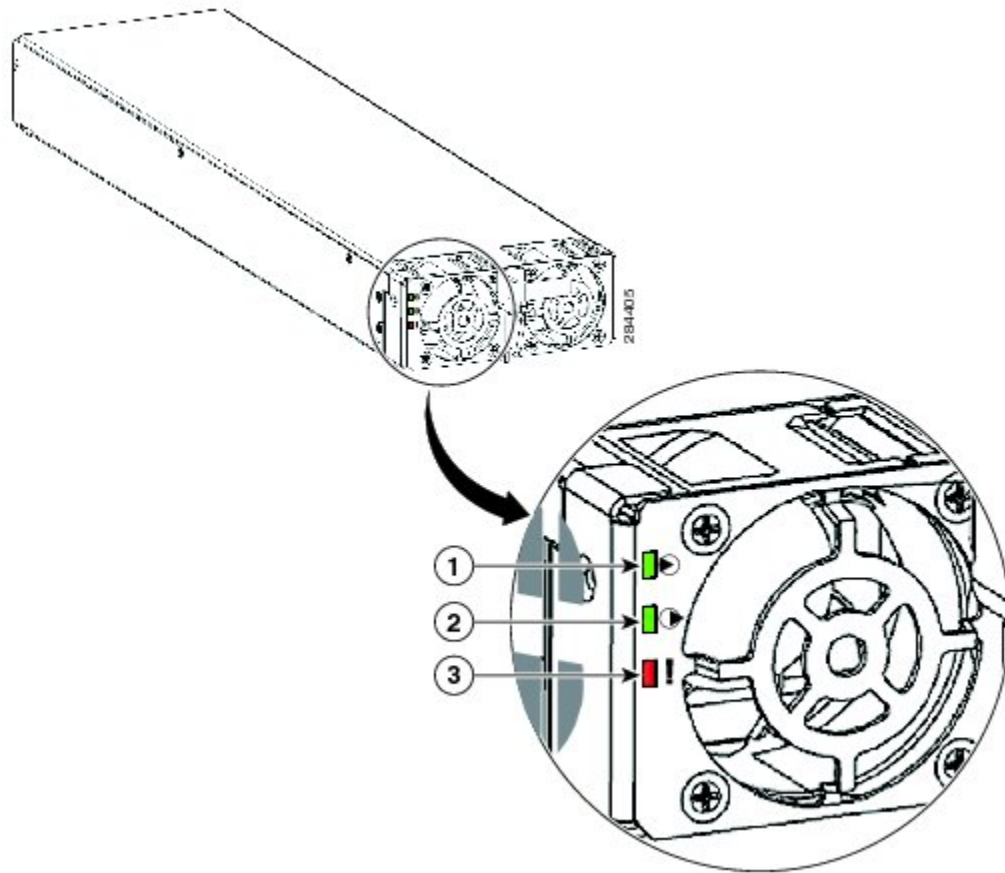
Figure 62: Version 1 Power Module Status Indicators



1	Input LED	ON continuously when the input voltage is present and within the correct range. BLINKING when the input voltage is out of acceptable range. OFF when no input voltage is present.
2	Output LED	ON when the power module output voltage is present. BLINKING when the power module is in a power limit or overcurrent condition.
3	Fault LED	ON indicates that a power supply failure has occurred.

The following figure shows the status indicators for the version 2 power module. The status indicators for the version 3 power module are similar.

Figure 63: Version 2 Power Module Status Indicators



1	Input LED	ON continuously when the input voltage is present and within the correct range. BLINKING when the input voltage is out of acceptable range. OFF when no input voltage is present.
2	Output LED	ON when the power module output voltage is present. BLINKING when the power module is in a power limit or overcurrent condition.
3	Fault LED	ON indicates that a power supply failure has occurred.

System Power Redundancy

Both the AC and DC power systems have system power redundancy depending on the chassis configuration. Each tray can house up to four modules and can be configured for multiple power configurations. For more information about power system redundancy, see [Power Supply Redundancy](#).

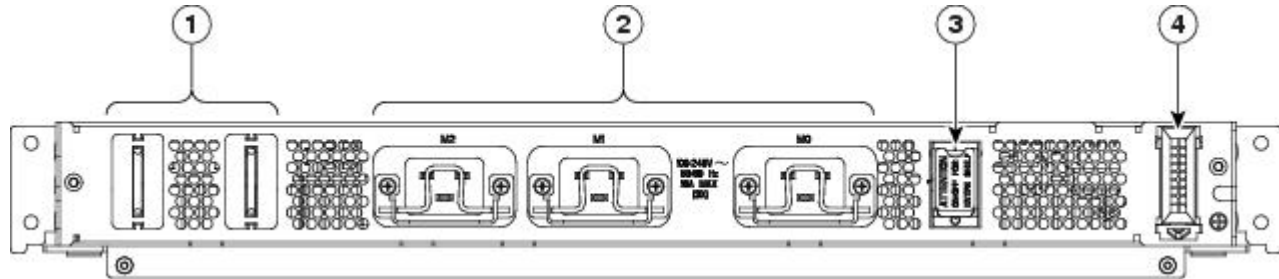
AC Power Trays

The AC power provides 20-A UL/CSA-rated, 16-IEC-rated AC receptacles. The version 1 receptacle has a bail lock retention bracket to retain the power cord. The version 2 and version 3 receptacles have a clamp mechanism with a screw that can be tightened to retain the power cord. DC output power from the is connected

to the router by two power blades that mate to the power bus on the backplane. System communication is through a I2C cable from the backplane.

The following figure shows the back of the version 1.

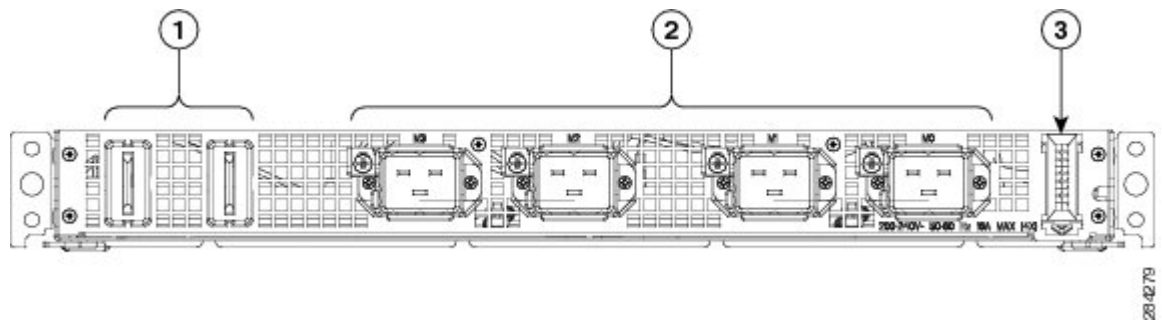
Figure 64: Version 1 Rear Panel



1 DC output power blades	3 Power switch
2 IEC input receptacles with retention brackets	4 I2C cable from backplane

The following figure shows the back of the version 2

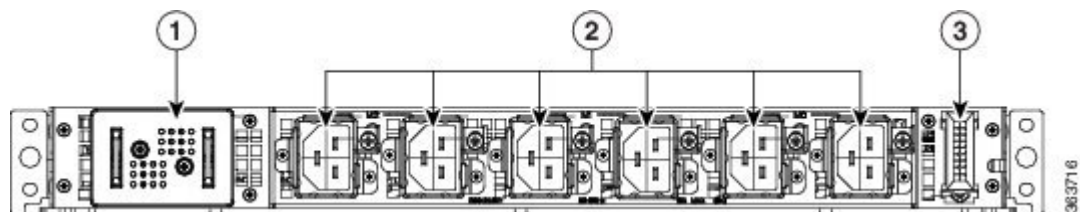
Figure 65: Version 2 Rear Panel



1 DC output power blades	3 I2C cable from backplane
2 IEC input receptacles with retention brackets	

The following figure shows the back of the version 3

Figure 66: Version 3 Rear Panel

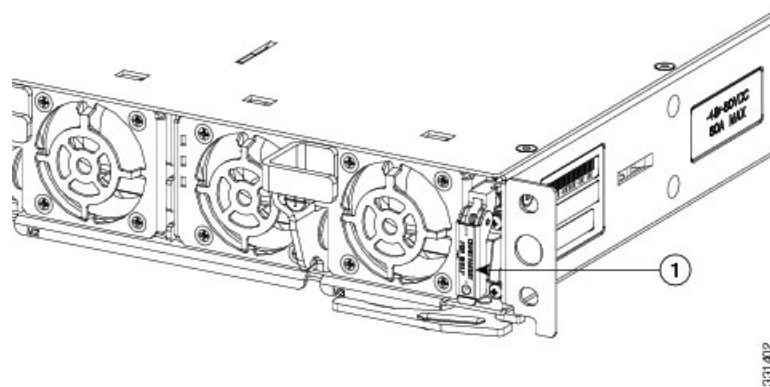


1 DC output power blades	3 I2C cable from backplane
2 IEC input receptacles with retention brackets	

AC Tray Power Switch

Each provides a single-pole, single-throw power switch to power on and put in standby mode all power modules installed in the tray simultaneously. When the power modules are turned off, only the DC output power is turned off; the power module fans and LEDs still function. The power switch for the version 1 power tray is on the back of the tray, as shown in the following figure. The power switch for the version 2 and version 3 power tray is on the front is shown in the following figure.

Figure 67: Location of AC Power Switch - Version 2 and Version 3 Power System



1. Power switch

AC Input Voltage Range

Each AC module accepts an individual single phase 220-VAC 20-A source. [AC Input Voltage Range](#) shows the limits of the specified AC input voltage. The voltages given are single phase power source.

DC Output Levels

The output for each module is within the tolerance specifications ([Power System DC Output Levels](#)) under all combinations of input voltage variation, load variation, and environmental conditions. The combined, total module output power does not exceed 3000 W.

The AC tray output capacity depends on how many modules are populated. Maximum output current is determined by multiplying the maximum module current times module quantity. For example, to determine the maximum capacity with three power supply modules, multiply the current by three (x3).

AC System Operation

This section describes the normal sequence of events for system AC power up and power down.

Power Up

1. AC power is applied to the power tray by toggling the user's AC circuit breakers to the ON position.
2. AC/DC power supplies are enabled by toggling the Power On/Off logic switch located in each of the power trays to the ON position.
3. AC/DC modules in the power trays provide -54 VDC output within six seconds after the AC is applied.

4. The soft-start circuit in the logic cards takes 100 milliseconds to charge the input capacitor of the on-board DC/DC converters.
5. The card power controller MCU enables the power sequencing of the DC/DC converters and points of load (POLs) through direct communication using the PMBus interface to digital controllers.
6. The output of the DC/DC converters ramps up to regulation within 50 milliseconds maximum after the program parameters are downloaded to each POL and the On/Off control pin has been asserted.

Power Down

1. Power conversion is disabled by toggling the Power On/Off logic switch to the OFF position or unplugging the power cords from the AC power source.
2. The AC/DC modules in the power trays stay within regulation for a minimum of 15 milliseconds after the AC power is removed.
3. The -54 V to the logic card ramps down to -36 V in 15 milliseconds minimum from the time the AC/DC modules starts ramping down from its minimum regulation level.
4. The DC/DC converters turn off immediately after the On/Off control pin is deasserted.
5. The output of the DC/DC converters stays in regulation for an additional 0.1 millisecond.

DC Power Trays

The DC power tray ([DC Power Tray Rear Panel, on page 90](#)) provides two power feed connector banks: A feed and B feed. System communication is through a I2C cable from the backplane.

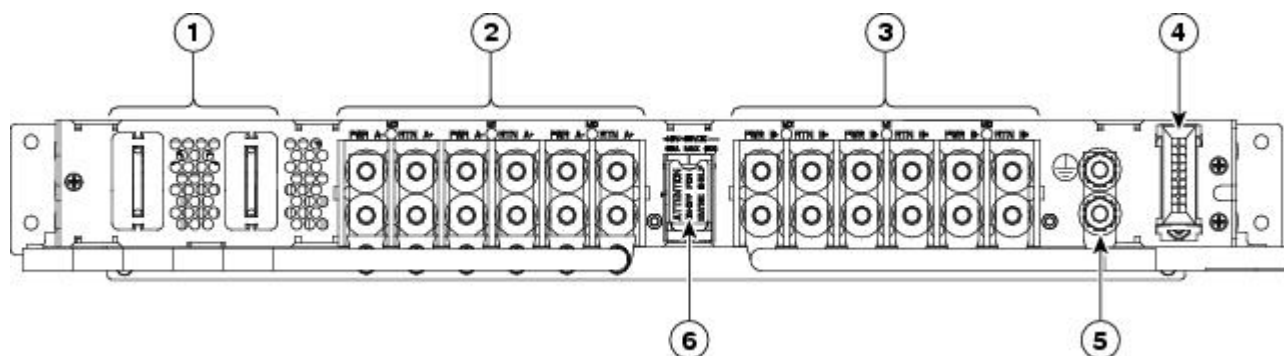
DC Tray Power Switch

Each DC power tray provides a single-pole, single-throw power switch to power on and off all of the power modules installed in the tray simultaneously. When the power modules are turned off, only the DC output power is turned off; the power module fans and LEDs still function. The power switch is on the front panel.

DC Power Tray Rear Panel

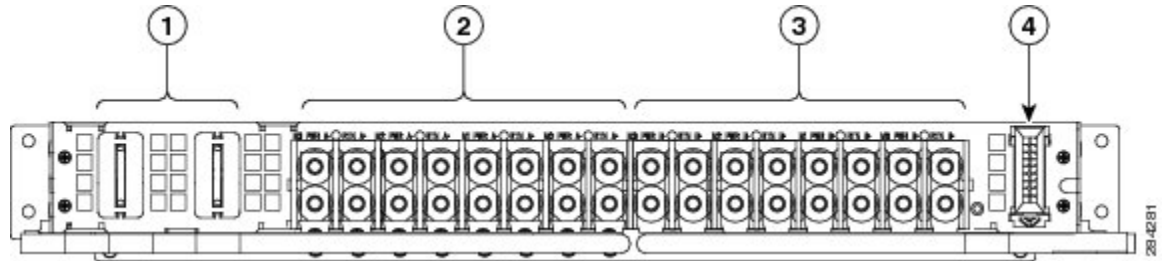
[Figure 68: DC Power Tray Rear Panel, on page 90](#) shows the rear panel of the power tray for the version 1 power system. [Figure 69: DC Power Tray Rear Panel - Cisco ASR 9006 Router and Cisco ASR 9904 Router \(Version 2 Power System\), on page 91](#) shows the rear panel of the power tray for the version 2 power system. [Figure 70: DC Power Tray Rear Panel—Version 3 Power System, on page 91](#) shows the rear panel of the power tray for the version 3 power system.

Figure 68: DC Power Tray Rear Panel



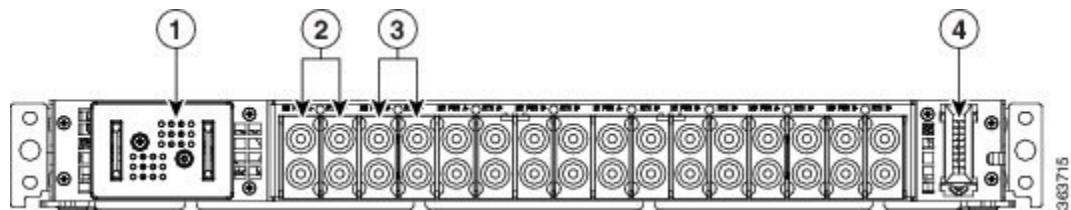
1 DC output power blades	4 I2C cable from backplane
2 “A” power feed connectors	5 Primary ground
3 “B” power feed connectors	6 Power switch

Figure 69: DC Power Tray Rear Panel - Cisco ASR 9006 Router and Cisco ASR 9904 Router (Version 2 Power System)



1 DC output power blades	3 “B” power feed connectors
2 “A” power feed connectors	4 I2C cable from backplane

Figure 70: DC Power Tray Rear Panel—Version 3 Power System



1 DC output power blades	3 “B” power feed connectors
2 “A” power feed connectors	4 I2C cable from backplane

DC System Operation

This section describes the normal sequence of events for system DC power up and power down.

Power Up

1. DC power is applied to the power tray by toggling the user’s DC circuit breakers to “ON” position.
2. DC/DC power supplies are enabled by toggling the Power On/Off logic switch located in each of the power tray to ON position.
3. DC/DC power supply modules in the power tray provides –54 VDC output within seven seconds after the DC is applied.
4. The soft-start circuit in the logic cards takes 100 milliseconds to charge the input capacitor of the on-board DC/DC converters.
5. The card power controller, MCU, enables the power sequencing of the DC/DC converters and POLs through direct communication using a PMBus interface to digital controllers such as LT7510 or through a digital wrapper such as LT2978.

6. The output of the DC/DC converters ramp up to regulation within 50 milliseconds maximum. after the program parameters are downloaded to each POL and On/Off control pin has been asserted.

Power Down

1. Power conversion is disabled by toggling the Power On/Off logic switch in the power tray to OFF position.
2. The DC/DC modules in the power tray stays within regulation for a minimum of 3.5 milliseconds after the Power On/Off logic switch is disabled.
3. The –54V DC to the logic card ramps down to –36 VDC in 3.5 milliseconds minimum from the time the DC/DC modules starts ramping down from its minimum regulation level.
4. The DC/DC converters powers off immediately after the On/Off pin is deasserted.
5. The output of the DC/DC converters stays in regulation for an additional 0.1 millisecond.

Cooling System Functional Description

The Cisco ASR 9000 Series Routers chassis is cooled by removable fan trays. The fan trays provide full redundancy and maintain required cooling if a single fan failure should occur. The following table describes the cooling paths for each router.

Table 11: Cooling Paths for the Cisco ASR 9000 Series Routers

Cisco ASR 9000 Series Routers	Chassis Cooling Path
Cisco ASR 9010 Router	Front-to-rear cooling path (Figure 71: Cisco ASR 9010 Router Chassis Cooling Path—Side View , on page 93). The inlet is at the bottom front of the chassis, and the exhaust is at the upper rear.
Cisco ASR 9006 Router	Side-to-top to rear cooling path (Figure 72: Cisco ASR 9006 Router Chassis Cooling Path , on page 93). The inlet is at the right side of the chassis, and the exhaust is at the upper rear.
Cisco ASR 9904 Router	Side-to-side cooling path (Figure 73: Cisco ASR 9904 Router Chassis Cooling Path, on page 94). The inlet is at the right side of the cage, and the exhaust is at the left side.
Cisco ASR 9906 Router	Front-to-top-to-rear cooling path (Figure 74: Cisco ASR 9906 Router Chassis Cooling Path, on page 94). The inlet is at the bottom front of the chassis, and the exhaust is at the lower rear.
Cisco ASR 9910 Router	Front-to-rear cooling path (Figure 75: Cisco ASR 9910 Router Chassis Cooling Path—Side View , on page 95). The inlet is at the bottom front of the chassis, and the exhaust is at the upper rear.
Cisco ASR 9922 Router	Front-to-rear cooling path (Figure 76: Cisco ASR 9922 Router Chassis Cooling Path—Side View , on page 96). The inlet is at the front of the middle cage, and the exhaust is at the upper and lower rear.
Cisco ASR 9912 Router	Front-to-rear cooling path (Figure 77: Cisco ASR 9912 Router Chassis Cooling Path—Side View , on page 97). The inlet is at the bottom front of the chassis, and the exhaust is at the upper rear

Figure 71: Cisco ASR 9010 Router Chassis Cooling Path—Side View

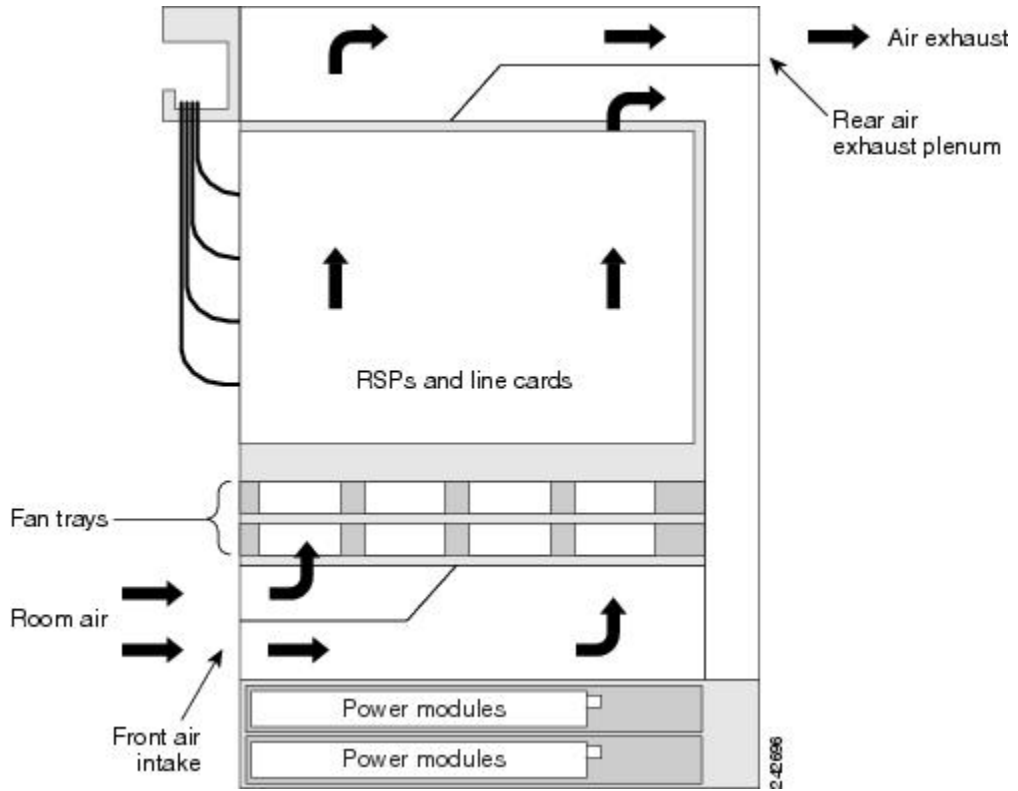


Figure 72: Cisco ASR 9006 Router Chassis Cooling Path

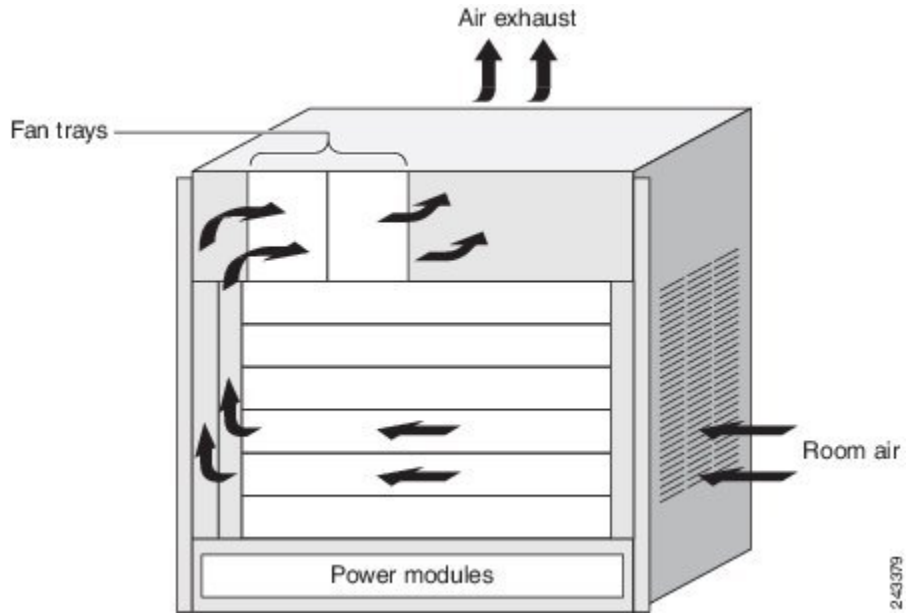


Figure 73: Cisco ASR 9904 Router Chassis Cooling Path

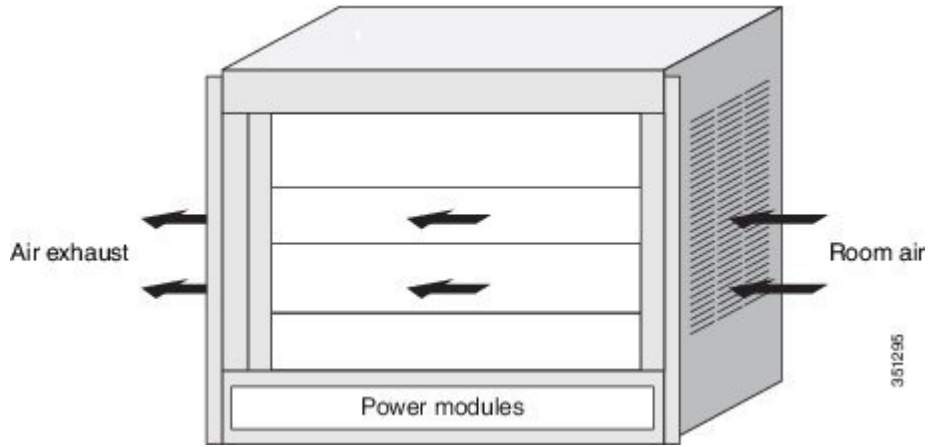


Figure 74: Cisco ASR 9906 Router Chassis Cooling Path

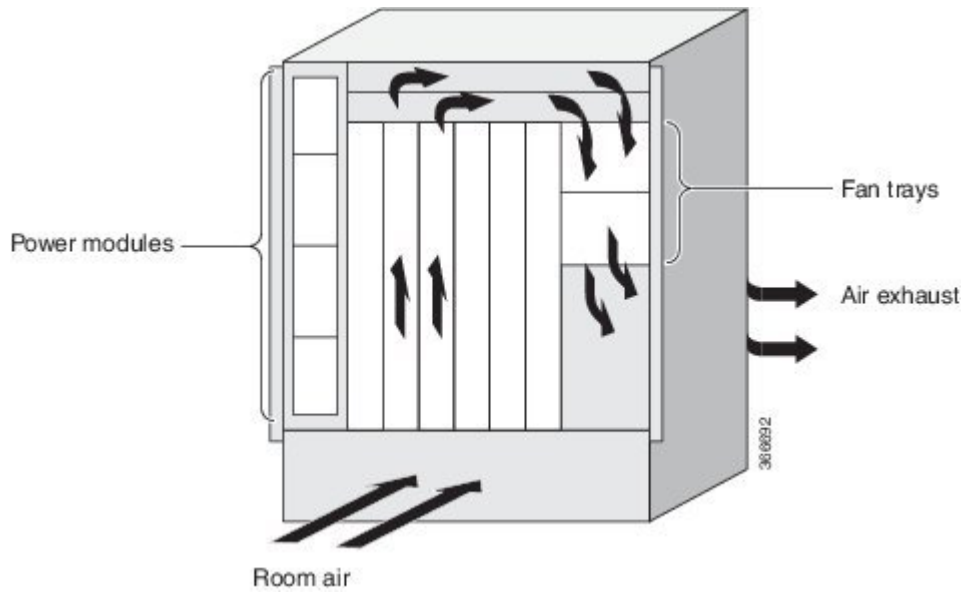
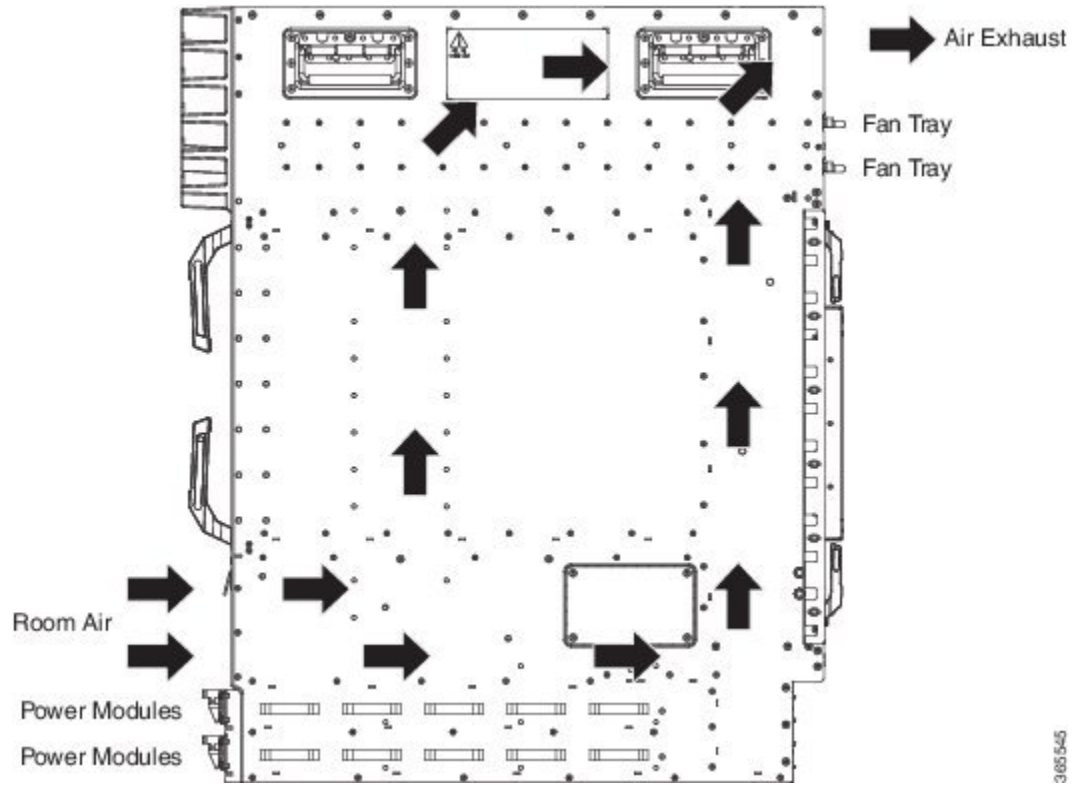
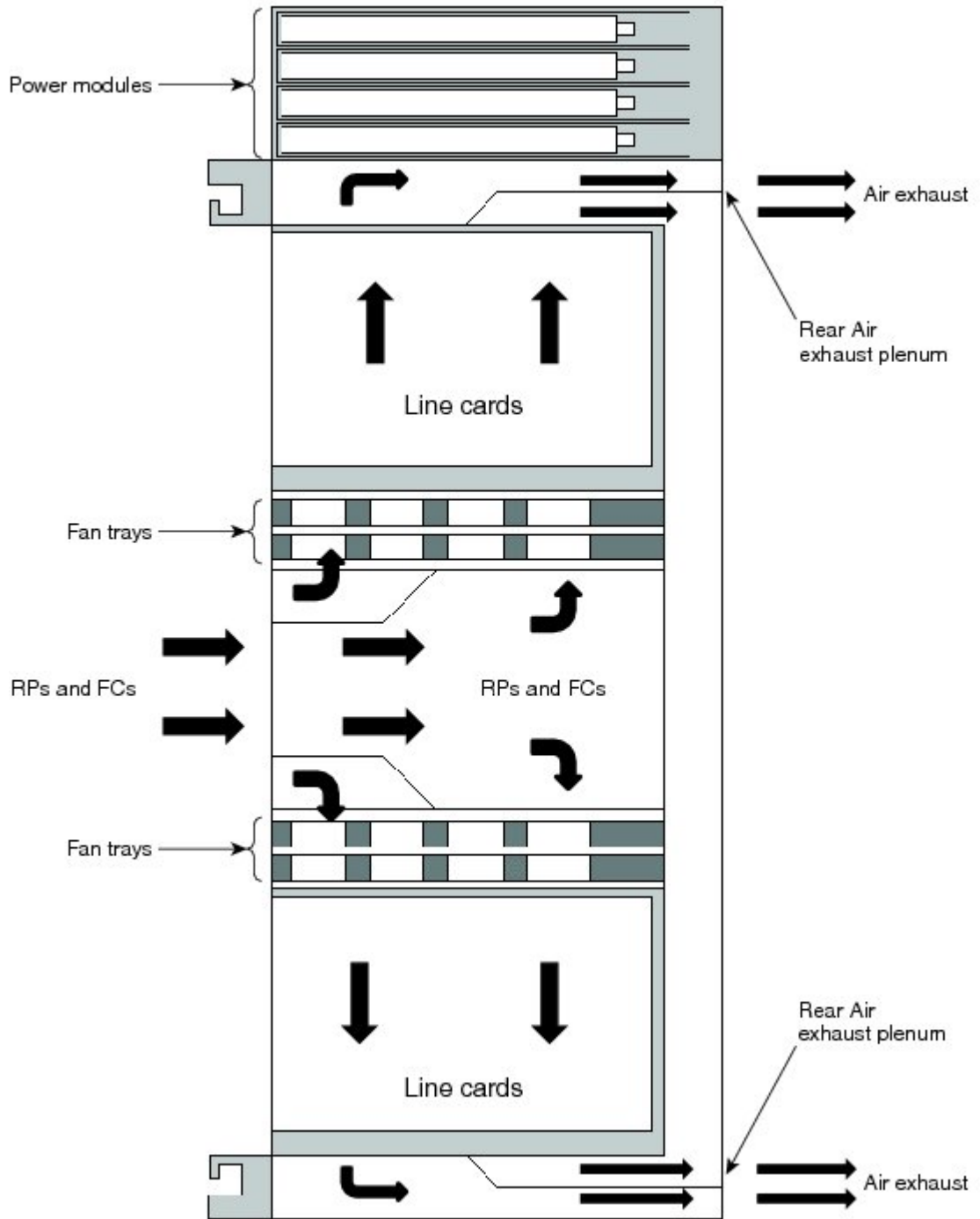


Figure 75: Cisco ASR 9910 Router Chassis Cooling Path—Side View



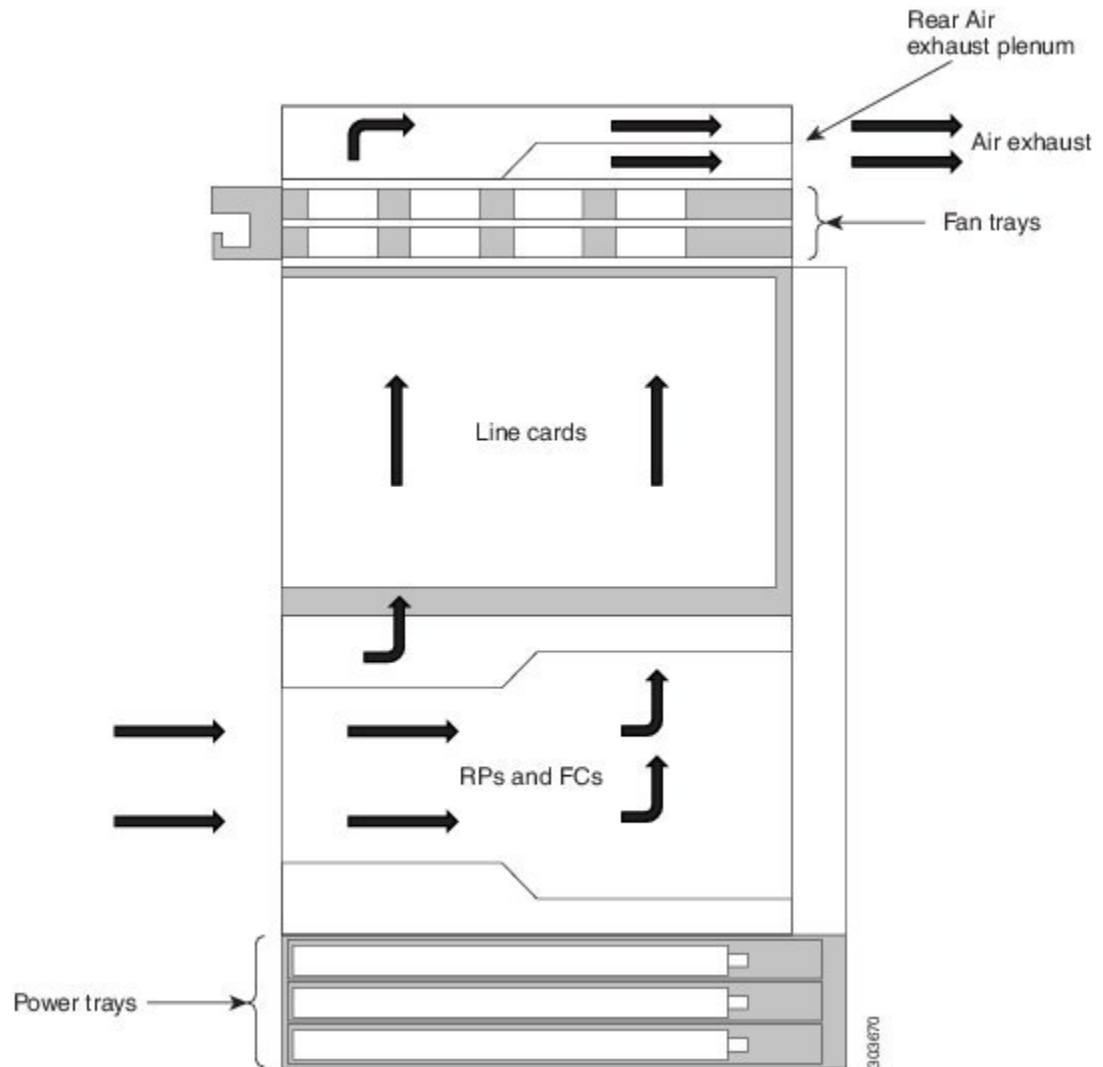
385545

Figure 76: Cisco ASR 9922 Router Chassis Cooling Path—Side View



343857

Figure 77: Cisco ASR 9912 Router Chassis Cooling Path—Side View



Fan Trays

Cisco ASR 9010 Router Fan Trays

The Cisco ASR 9010 Router contains two fan trays for redundancy. The fan tray has an LED indicator to indicate fan tray status. If a fan tray fails, it is possible to swap a single fan tray assembly while the system is operational. Fan tray removal does not require removal of any cables.

- Fan tray status LED
- The fan tray contains 12 axial 120-mm (4.72-in) fans. There is a fan control board at the back end of each tray with a single power/data connector that connects with the backplane.
- The fan tray aligns through two guide pins inside the chassis, and it is secured by two captive screws. The controller board floats within the fan tray to allow for alignment tolerances.

- A finger guard is adjacent to the front of most fans to keep fingers away from spinning fan blades during removal of the fan tray.
- The maximum weight of the fan tray is 13.82 lb (6.29 kg).

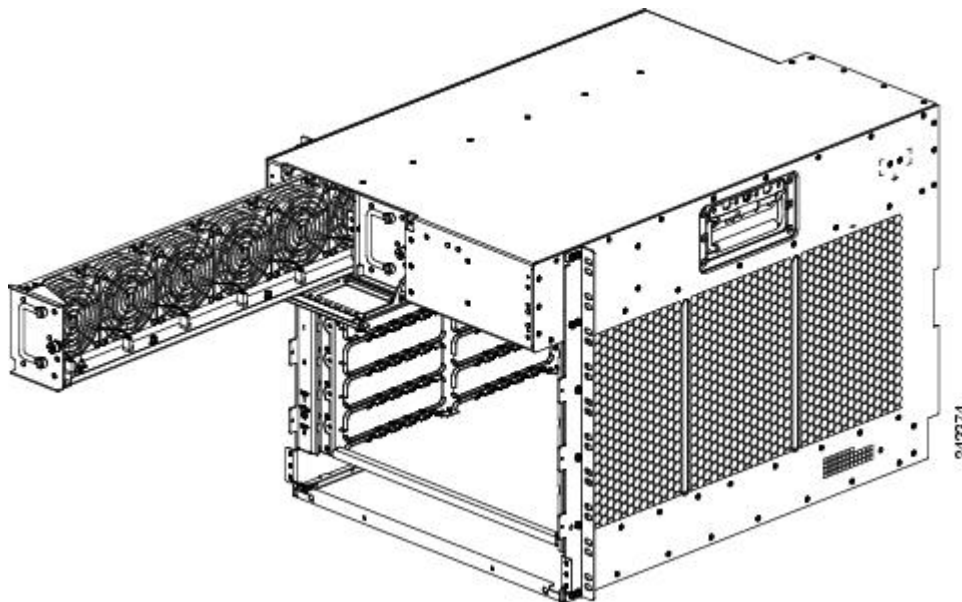
Cisco ASR 9006 Router Fan Trays

The Cisco ASR 9006 Router contains two fan trays for redundancy. If a fan tray fails, it is possible to swap a single fan tray assembly while the system is operational. Fan tray removal does not require removal of any cables.



Note Both fan trays are required for normal system operation for the Cisco ASR 9010 Router and Cisco ASR 9006 Router. If both fan trays in the router are pulled out or are not installed, a critical alarm is raised.

Figure 78: Cisco ASR 9006 Router Fan Tray

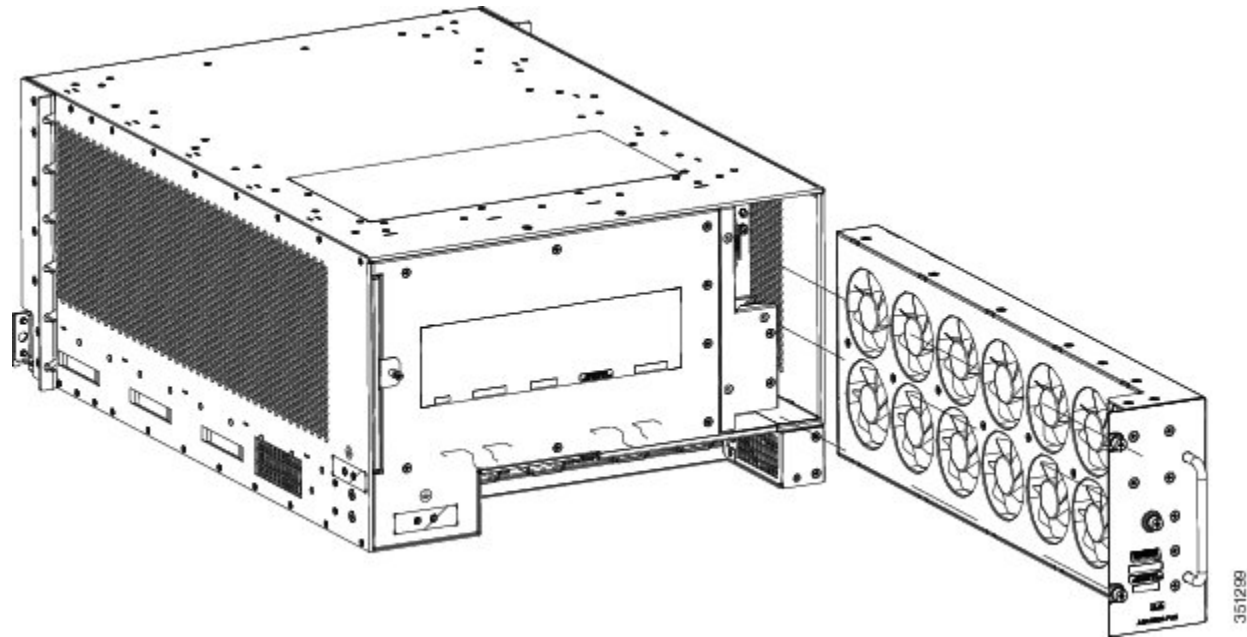


- The fan tray contains six axial 92-mm (3.62-in) fans. There is a fan control board at the back end of each tray with a single power/data connector that connects with the backplane.
- The fan tray aligns through two guide pins inside the chassis, and is secured by one captive screw. The controller board floats within the fan tray to allow for alignment tolerances.
- A finger guard is adjacent to the front of most of the fans to keep fingers away from spinning fan blades during removal of the fan tray.
- The maximum weight of the fan tray is 39.7 lb (18.0 kg).

Cisco ASR 9904 Router Fan Tray

The Cisco ASR 9904 Router contains a single fan tray. If a fan tray fails, it is possible to swap a single fan tray assembly while the system is operational. Replace the missing fan tray within 4 minutes.

Figure 79: Cisco ASR 9904 Router Fan Tray



- The fan tray contains twelve axial 88-mm (3.46-in) fans. There is a fan control board at the back end of the tray with a single power/data connector that connects with the backplane
- The fan tray aligns through two guide pins inside the chassis, and it is secured by one captive screw. The controller board floats within the fan tray to allow for alignment tolerances.
- A finger guard is adjacent to the front of most of the fans to keep fingers away from spinning fan blades during removal of the fan tray.
- The maximum weight of the fan tray is 11.0 lb (4.99 kg).

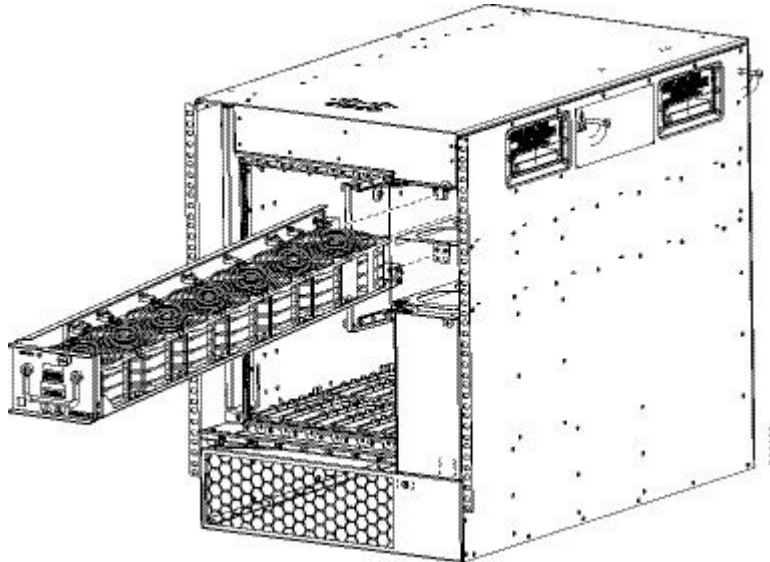
Cisco ASR 9906 Router Fan Trays

The Cisco ASR 9906 Router contains two fan trays for redundancy. If a fan tray fails, it is possible to swap a single fan tray assembly while the system is operational. Fan tray removal does not require removal of any cables.



Note Both fan trays are required for normal system operation for the Cisco ASR 9906 Router. If both fan trays in the router are pulled out or are not installed, a critical alarm is raised.

Figure 80: Cisco ASR 9906 Router Fan Tray



- The fan tray contains seven axial 92-mm (3.62-in) fans. There is a fan control board at the back end of each tray with a single power/data connector that connects with the backplane.
- The fan tray aligns through two guide pins inside the chassis, and is secured by one captive screw. The controller board floats within the fan tray to allow for alignment tolerances.
- A finger guard is adjacent to the front of most of the fans to keep fingers away from spinning fan blades during removal of the fan tray.
- The maximum weight of the fan tray is 8.0 lb (3.63 kg).

Cisco ASR 9910 Router Fan Trays

The Cisco ASR 9910 Router contains two fan trays for redundancy. The fan tray has an LED indicator to indicate fan tray status. If a fan tray fails, it is possible to swap a single fan tray assembly while the system is operational. Fan tray removal does not require removal of any cables.

1. Fan tray status LED
2. The fan tray contains 12 axial 134-mm (5.27-in) fans. There is a fan control board at the back end of each tray with a single power/data connector that connects with the backplane.
3. The fan tray aligns through two guide pins inside the chassis, and it is secured by two captive screws. The controller board floats within the fan tray to allow for alignment tolerances.
4. A finger guard is adjacent to the front of most fans to keep fingers away from spinning fan blades during removal of the fan tray.
5. The maximum weight of the fan tray is 26.55 lb (12.04 kg).

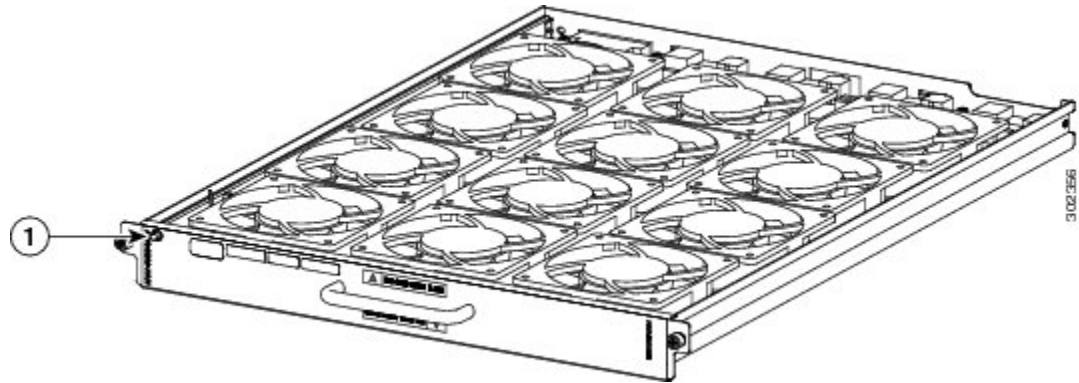
Cisco ASR 9922 Router and Cisco ASR 9912 Router Fan Trays

The Cisco ASR 9922 Router contains four fan trays, and the Cisco ASR 9912 Router contains three fan trays for redundancy. The fan tray has an LED indicator to indicate fan tray status. If a fan tray fails, it is possible to swap a single fan tray assembly while the system is operational. Fan tray removal does not require removal of any cables.



Note Do not operate the chassis with any of the fan trays completely missing. Replace any missing fan tray within five minutes.

Figure 81: Cisco ASR 9922 Router and Cisco ASR 9912 Router Fan Tray



1. Fan tray status LED
2. The fan tray contains 12 axial 120-mm (4.72-in) fans. There is a fan control board at the back end of each tray with a single power/data connector that connects with the backplane.
3. The fan tray aligns through two guide pins inside the chassis, and it is secured by two captive screws. The controller board floats within the fan tray to allow for alignment tolerances.
4. A finger guard is adjacent to the front of most fans to keep fingers away from spinning fan blades during removal of the fan tray.
5. The maximum weight of the fan tray is 18.00 lb (8.16 kg).
6. The fan tray width is increased from 16.3 inches to 17.3 inches. The overall fan tray depth remains the same at 23 inches. The individual fan current rating is increased to 2 A to support higher speeds.

Fan Tray Status Indicators

The fan tray has a Run/Fail status LED on the front panel to indicate fan tray status.

After fan tray insertion into the chassis, the LED lights up temporarily appearing yellow. During normal operation:

- The LED lights green to indicate that all fans in the module are operating normally.
- The LED lights red to indicate a fan failure or another fault in the fan tray module. Possible faults are:
 - Fan stopped.
 - Fans running below required speed to maintain sufficient cooling.
 - Controller card has a fault.

Fan Tray Servicing

No cables or fibers must be moved during installation or removal of the fan tray(s). Replacing fan trays does not interrupt service.

Slot Fillers

To maintain optimum cooling performance in the chassis and at the slot level, unused slots must be filled with card blanks or flow restrictors. These slot fillers are simple sheet metal only and are not active. Software cannot detect their presence.

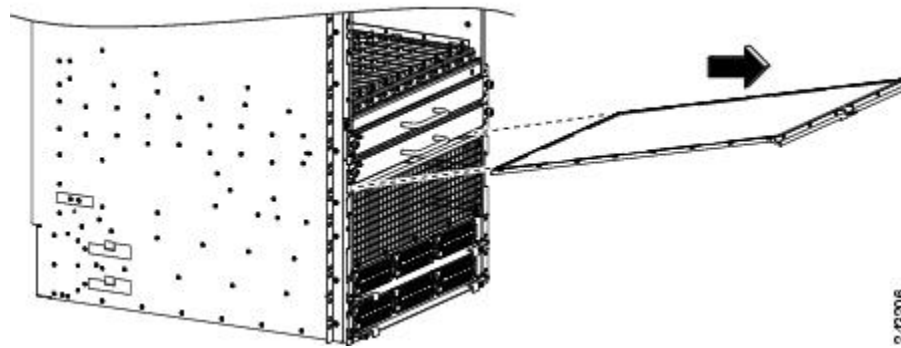
Chassis Air Filters (Version 1 and Version 2)

The chassis air filters in the Cisco ASR 9000 Series Routers are NEBS compliant. The filter is not serviceable but is a field replaceable unit. Replacing the filter does not interrupt service. The following table describes the chassis air filter locations for the Cisco ASR 9000 Series Routers.

Table 12: Chassis Air Filter Locations for the Cisco ASR 9000 Series Routers

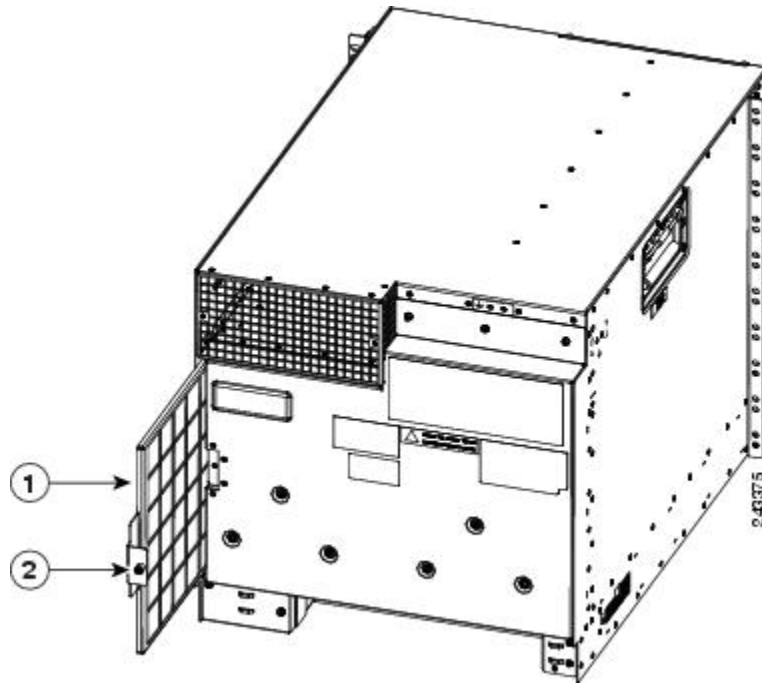
Cisco ASR 9000 Series Routers	Air Filter Locations
Cisco ASR 9010 Router	A single air filter is located underneath the fan trays (Figure 82: Cisco ASR 9010 Router Chassis Air Filter, on page 103).
Cisco ASR 9006 Router	A single air filter is located along the right side of the chassis, and is accessible from the rear of the chassis (Figure 83: Cisco ASR 9006 Router Chassis Air Filter, on page 103).
Cisco ASR 9904 Router	A single air filter is located along the right side of the chassis, and is accessible from the rear of the chassis (Figure 84: Cisco ASR 9904 Router Air Filter, on page 104).
Cisco ASR 9906 Router	A single air filter is located underneath the line card cage, accessible from the front of the chassis (Figure 85: Cisco ASR 9906 Router Chassis Air Filter, on page 104).
Cisco ASR 9910 Router	A single air filter is located underneath the fan trays (Figure 86: Cisco ASR 9910 Router Chassis Air Filter, on page 105).
Cisco ASR 9922 Router	Three air filters are located on the middle cage (Figure 87: Cisco ASR 9922 Router Chassis Air Filters—Version 1, on page 105). The center air filter covers the front of the FC cards. Figure 88: Cisco ASR 9922 Router Chassis Air Filter—Version 2, on page 106 shows the version 2 center air filter. The side air filters cover the RP cards. Figure 90: Cisco ASR 9922 Router Chassis Side Air Filter—Versions 1 and 2, on page 107 shows how to replace the foam media inside one of the two side air filters.
Cisco ASR 9912 Router	Three air filters on the RP/FC card cage (Figure 91: Cisco ASR 9912 Router Chassis Air Filters, on page 108). The center air filter covers the front of the FC cards. The side air filters cover the RP cards.

Figure 82: Cisco ASR 9010 Router Chassis Air Filter



2-432016

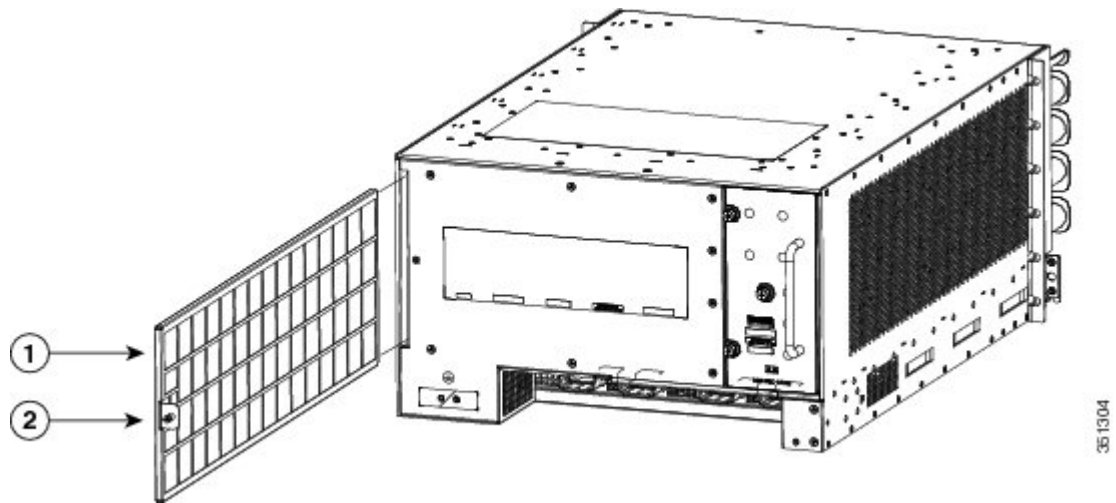
Figure 83: Cisco ASR 9006 Router Chassis Air Filter



2-433715

1	Air filter	2	Thumb screw
---	------------	---	-------------

Figure 84: Cisco ASR 9904 Router Air Filter



1	Air filter	2	Thumb screw
---	------------	---	-------------

Figure 85: Cisco ASR 9906 Router Chassis Air Filter

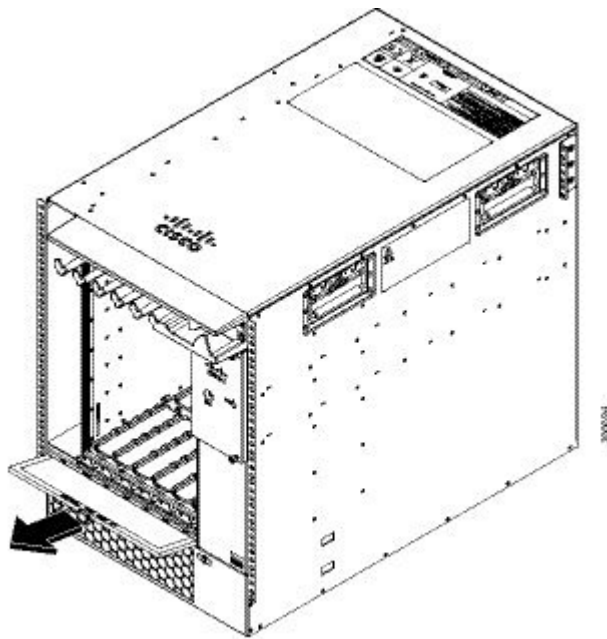


Figure 86: Cisco ASR 9910 Router Chassis Air Filter

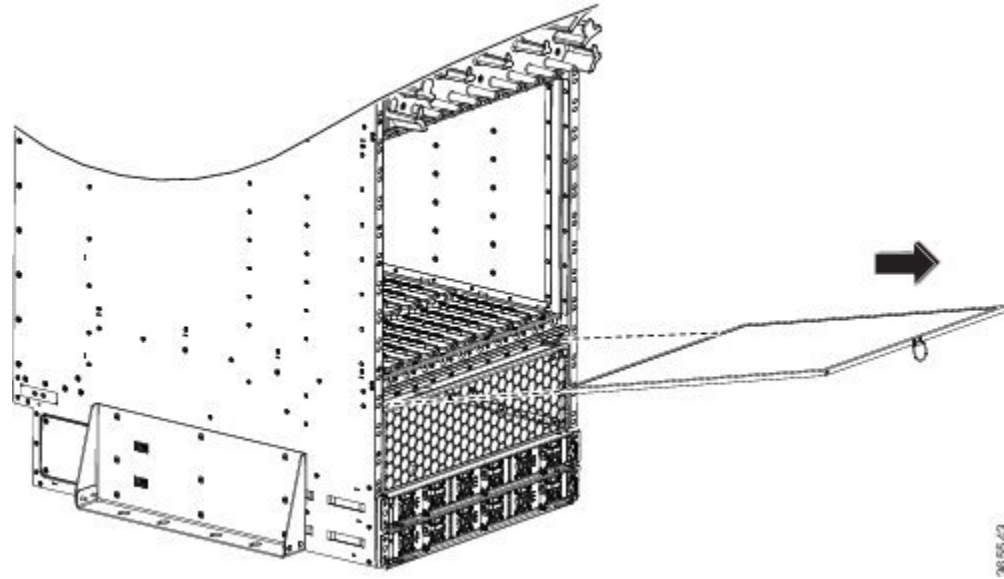


Figure 87: Cisco ASR 9922 Router Chassis Air Filters—Version 1

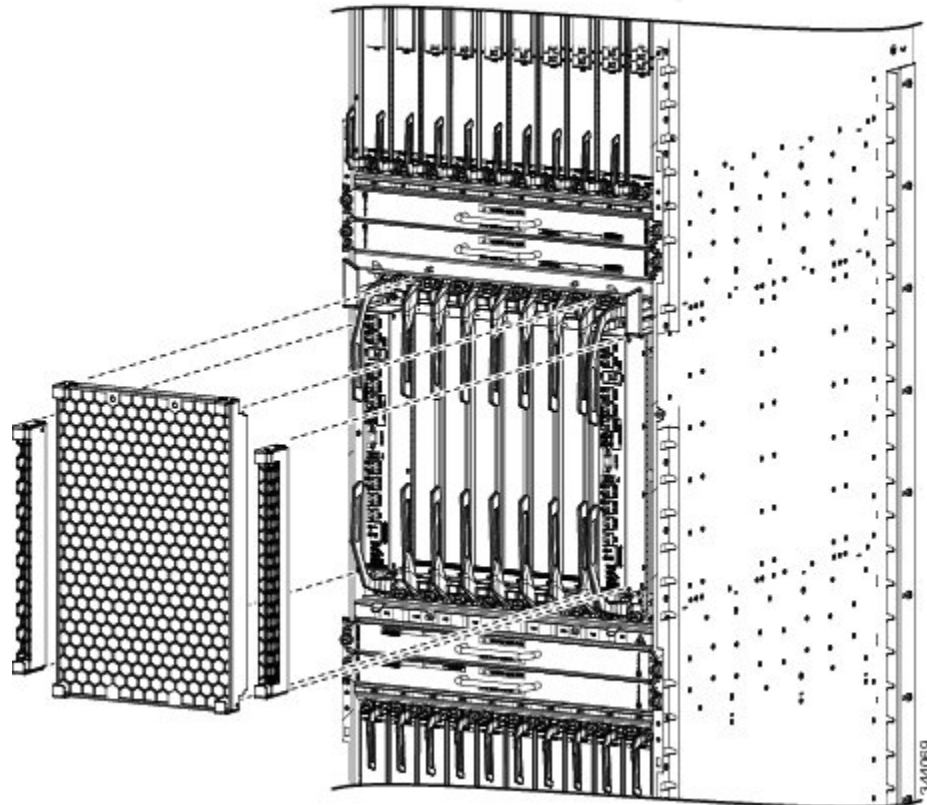


Figure 88: Cisco ASR 9922 Router Chassis Air Filter—Version 2

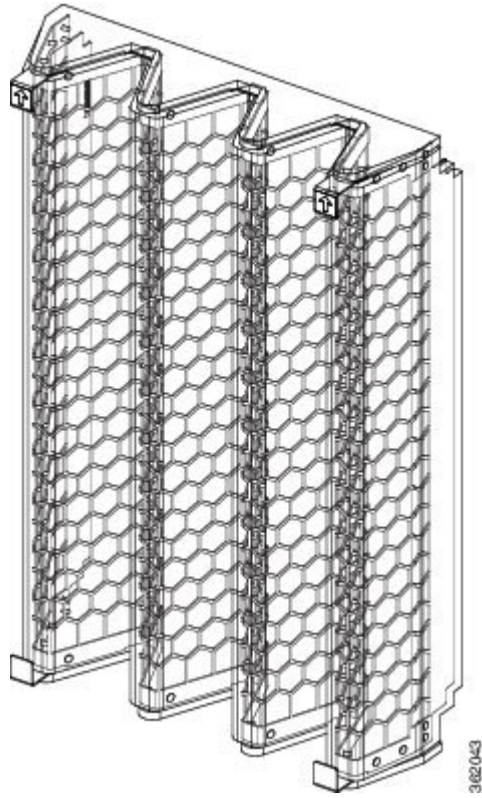
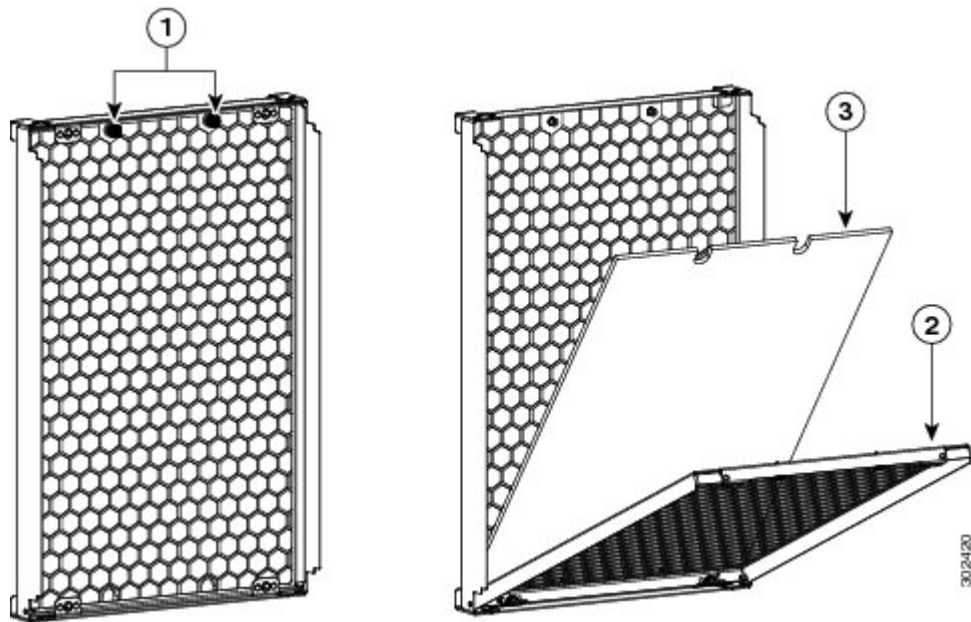


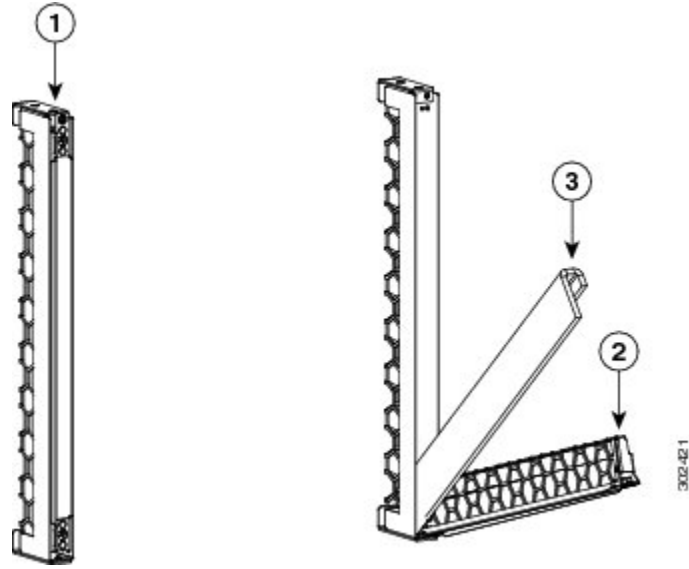
Figure 89: Cisco ASR 9922 Router Chassis Center Air Filter—Version 1



1	Loosen thumb screws	3	Remove foam filter media
---	---------------------	---	--------------------------

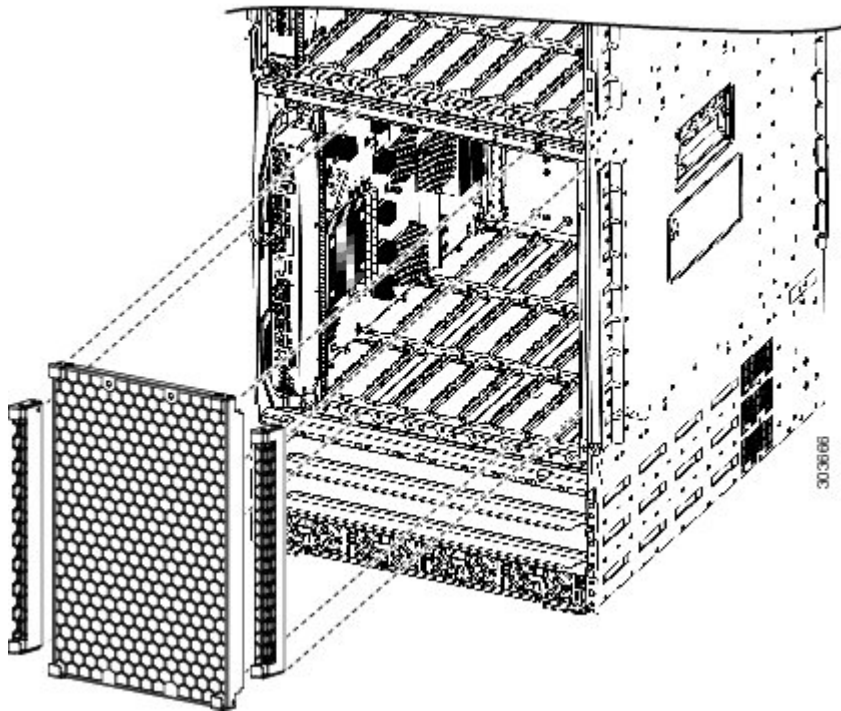
2	Rotate and lower inner frame		
---	------------------------------	--	--

Figure 90: Cisco ASR 9922 Router Chassis Side Air Filter—Versions 1 and 2



1	Loosen thumb screws	3	Remove foam filter media
2	Rotate and lower inner frame		

Figure 91: Cisco ASR 9912 Router Chassis Air Filters



Speed Control

The cooling system adjusts its speed to compensate for changes in system or external ambient temperatures. To reduce operating noise, the fans have variable speeds. Speed can also vary depending on system configurations that affect total power dissipation. If lower power cards are installed, the system could run at slower speeds; if higher power cards are installed, the system could run at faster speeds.

Fan speed is managed by the RSP/RP card and the controller card in the fan tray. The RSP/RP monitors card temperatures and sends a fan speed to the controller card.

If the failure of a single fan within a module is detected, the failure causes an alarm and all the other fans in the fan tray go to full speed.



Note Complete failure of one fan tray causes the remaining fan tray to operate its fans at full speed continuously until a replacement fan tray is installed.

Temperature Sensing and Monitoring

Temperature sensors are present on cards to monitor the internal temperatures. Line cards and RSP/RP cards have their leading edge (inlet) and hottest spot continuously monitored by temperature sensors. Some cards have additional sensors located near hot components that need monitoring. Some ASICs have internal diodes that might be used to read junction temperatures.

- If the ambient air temperature is within the normal operating range, the fans operate at the lowest speed possible to minimize noise & power consumption.
- If the air temperature in the card cage rises, fan speed increases to provide additional cooling air to the internal components. If a fan fails, the others increase in speed to compensate.

Fan tray removal triggers environmental alarms and increases the fan speed of the remaining tray to its maximum speed.

Servicing

The system is populated with two fan trays for redundancy. If a fan tray failure occurs, it is possible to swap a single fan tray assembly while the system is operational. Assuming redundant configuration, removal of a fan tray results in zero packet loss.

Fan tray removal does not require removal of any cables.

System Shutdown

When the system reaches critical operating temperature points, it triggers a shutdown sequence of the system.

System Management and Configuration

The Cisco IOS XR Software on the ASR 9000 Series Routers provides the system manageability interfaces: CLI, XML, and SNMP.

Cisco IOS XR Software

The ASR 9000 Series Routers run Cisco IOS XR Software and use the manageability architecture of that operating system, which includes CLI, XML, and SNMP. Craft Works Interface (CWI), a graphical craft tool for performance monitoring, is embedded with the Cisco IOS XR Software and can be downloaded through the HTTP protocol. However, the ASR 9000 Series Routers support only a subset of CWI functionality. In this mode, a user can edit the router configuration file, open Telnet/SSH application windows, and create user-defined applications.

System Management Interfaces

The system management interfaces consist of the CLI, XML, and SNMP protocols. By default, only CLI on the console is enabled. When the management LAN port is configured, various services can be started and used by external clients, such as Telnet, SSH, and SNMP. In addition, TFTP and Syslog clients can interact with external servers. CWI can be downloaded and installed on a PC or Solaris box.

For information about SNMP, see [SNMP, on page 110](#).

All system management interfaces have fault and physical inventory.

Command-Line Interface

The CLI supports configuration file upload and download through TFTP. The system supports generation of configuration output without any sensitive information such as passwords, keys, etc. The Cisco ASR 9000 Series Routers support Embedded Fault Manager (TCL-scripted policies) through CLI commands. The system also supports feature consistency between the CLI and SNMP management interfaces.

Craft Works Interface

The system supports CWI, a graphical craft tool for performance monitoring, configuration editing, and configuration rollback. CWI is embedded with Cisco IOS XR software and can be downloaded through the HTTP protocol. A user can use CWI to edit the router configuration file, create user-defined applications, and open Telnet/SSH application windows to provide CLI access.

XML

External (or XML) clients can programmatically access the configuration and operational data of the Cisco ASR 9000 Series Router using XML. The XML support includes retrieval of inventory, interfaces, alarms, and performance data. The system is capable of supporting 15 simultaneous XML/SSH sessions. The system supports alarms and event notifications over XML and also supports bulk PM retrieval and bulk alarms retrieval.

XML clients are provided with the hierarchy and possible contents of the objects that they can include in their XML requests (and can expect in the XML responses), documented in the form of an XML schema.

When the XML agent receives a request, it uses the XML Service Library to parse and process the request. The Library forwards the request to the Management Data API (MDA) Client Library, which retrieves data from the SysDB. The data returned to the XML Service Library is encoded as XML responses. The agent then processes and sends the responses back to the client as response parameter of the invoke method call. The alarm agent uses the same XML Service Library to notify external clients about configuration data changes and alarm conditions.

SNMP

The SNMP interface allows management stations to retrieve data and to get traps. It does not allow setting anything in the system.

SNMP Agent

In conformance with SMIV2 (Structure of Management Information Version 2) as noted in RFC 2580, the system supports SNMPv1, SNMPv2c, and SNMPv3 interfaces. The system supports feature consistency between the CLI and SNMP management interfaces.

The system is capable of supporting at least 10 SNMP trap destinations. Reliable SNMP Trap/Event handling is supported.

For SNMPv1 and SNMPv2c support, the system supports SNMP View to allow inclusion/exclusion of Miss for specific community strings. The SNMP interface allows the SNMP SET operation.

MIBs

The Device Management MIBs supported by the ASR 9000 Series Routers are listed at:

<http://cisco.com/public/sw-center/netmgmt/cmtk/mibs.shtml>

Online Diagnostics

System run-time diagnostics are used by the Cisco Technical Assistance Center (TAC) or the end user to troubleshoot a field problem and assess the state of a given system.

Some examples of the run-time diagnostics include the following:

- Monitoring line card to RSP/RP card communication paths
- Monitoring line card to RSP/RP card data path
- Monitoring CPU communication with various components on the line cards and RSP/RP cards



CHAPTER 3

High Availability and Redundant Operation

This chapter describes the high availability and redundancy features of the Cisco ASR 9000 Series Routers.

- [Features Overview, on page 113](#)
- [High Availability Router Operations, on page 113](#)
- [Power Supply Redundancy, on page 115](#)
- [Cooling System Redundancy, on page 124](#)

Features Overview

The Cisco ASR 9000 Series Routers are designed to have high Mean Time Between Failures (MTBF) and low Mean Time To Resolve (MTTR) rates, thus providing a reliable platform that minimizes outages or downtime and maximizes availability.

In addition, the Cisco ASR 9000 Series Routers offer the following high availability (HA) features to enhance network level resiliency and enable network-wide protection:

- [High Availability Router Operations, on page 113](#)
- [Power Supply Redundancy, on page 115](#)
- [Cooling System Redundancy, on page 124](#)

High Availability Router Operations

- [Stateful Switchover, on page 113](#)
- [Fabric Switchover, on page 114](#)
- [Non-Stop Forwarding, on page 114](#)
- [Process Restartability, on page 115](#)
- [Fault Detection and Management, on page 115](#)

Stateful Switchover

The RSP/RP cards are deployed in “active/standby” configurations. Stateful switchover (SSO) preserves state and configuration information if a switchover to the standby RSP/RP card occurs. The standby RSP/RP card has a mirror image of the state of protocols, users configuration, interface state, subscriber state, system state and other parameters. Should a hardware or software failure occur in the active RSP/RP card, the standby

RSP/RP card changes state to become the active RSP/RP card. This stateful switchover has no impact in forwarding traffic.

Fabric Switchover

- In the Cisco ASR 9010 Router, Cisco ASR 9006 Router, Cisco ASR 9904 Router, Cisco ASR 9906 Router, and Cisco ASR 9910 Router, the RSP card makes up most of the fabric. The fabric is configured in an “active/active” configuration model, which allows the traffic load to be distributed across both RSP cards. In the case of a failure, the single “active” switch fabric continues to forward traffic in the systems.
- In the Cisco ASR 9922 Router and Cisco ASR 9912 Router, fabric switching across the RP and line cards is provided by a separate set of seven OIR FC cards operating in 6+1 redundancy mode. Any FC card can be removed from the chassis, power-cycled, or provisioned to remain unpowered without impacting system traffic. All FC cards remain active unless disabled or faulty. Traffic from the line cards is distributed across all FC cards.

Active/Standby Status Interpretation

Status signals from each RSP/RP card are monitored to determine active/standby status and if a failure has occurred that requires a switchover from one RSP/RP card to the other.

Non-Stop Forwarding

Cisco IOS XR Software supports non-stop forwarding (NSF) to enable the forwarding of packets without traffic loss during a brief outage of the control plane. NSF is implemented through signaling and routing protocol implementations for graceful restart extensions as standardized by the Internet Engineering Task Force (IETF).

For example, a soft reboot of certain software modules does not hinder network processors, the switch fabric, or the physical interface operation of forwarding packets. Similarly, a soft reset of a non-data path device (such as a Ethernet Out-of-Band Channel Gigabit Ethernet switch) does not impact the forwarding of packets.

Nonstop Routing

Nonstop routing (NSR) allows forwarding of data packets to continue along known routes while the routing protocol information is being refreshed following a processor switchover. NSR maintains protocol sessions and state information across SSO functions for services such as MPLS VPN. TCP connections and the routing protocol sessions are migrated from the active RSP/RP card to the standby RSP/RP card after the RSP/RP switchover without letting peers know about the switchover. The sessions terminate and the protocols running on the standby RSP/RP card reestablish the sessions after the standby RSP/RP goes active. NSR can also be used with graceful restart to protect the routing control plane during switchovers. The NSR functionality is available only for Open Shortest Path First Protocol (OSPF) and Label Distribution Protocol (LDP) routing technologies.

Graceful Restart

Graceful restart (GR) provides a control plane mechanism to ensure high availability by allowing detection and recovery from failure conditions while preserving Nonstop Forwarding (NSF) services. Graceful restart is a way to recover from signaling and control plane failures without impacting the forwarding plane. Cisco

IOS XR Software uses graceful restart and a combination of check pointing, mirroring, route switch processor redundancy, and other system resiliency features to recover before a timeout and avoid service downtime as a result of network reconvergence.

Process Restartability

The Cisco IOS XR distributed and modular microkernel operating system enables process independence, restartability, and maintenance of memory and operational states. Each process runs in a protected address space. Checkpointing facilities, reliable transports, and retransmission features enable processes to be restarted without impacting other components and with minimal or no disruption of traffic. Usually any time a process fails, crashes or incurs any faults, the process restarts itself. For example, if a Border Gateway Protocol (BGP) or Quality of Service (QoS) process incurs a fault, it restarts to resume its normal routine without impacting other processes.

Fault Detection and Management

To minimize service outage, the Cisco ASR 9000 Series Routers provide rapid and efficient response to single or multiple system component or network failures. When local fault handling cannot recover from critical faults, the system offers robust fault detection, correction, failover, and event management capabilities.

- **Fault detection and correction**—In hardware, the Cisco ASR 9000 Series Routers offer error correcting code (ECC)-protected memory. If a memory corruption occurs, the system automatically restarts the impacted processes to fix the problem with minimum impact. If the problem is persistent, the Cisco ASR 9000 supports switchover and online insertion and removal (OIR) capabilities to allow replacement of defective hardware without impacting services on other hardware components in the system.
- **Resource management**—Cisco ASR 9000 Series Routers support resource threshold monitoring for CPU and memory utilization to improve out of resource (OOR) management. When threshold conditions are met or exceeded, the system generates an OOR alarm to notify operators of OOR conditions. The system then automatically attempts recovery, and allows the operator to configure flexible policies using the embedded event manager.
- **Online diagnostics**—Cisco ASR 9000 Series Routers provide built-in online diagnostics to monitor functions such as network path failure detection, packet diversion failures, faulty fabric link detections, etc. The tests are configurable through the CLI.
- **Event management**—Cisco ASR 9000 Series Routers offer mechanisms such as fault-injection testing to detect hardware faults during lab testing, a system watchdog mechanism to recover failed processes, and tools such as the Route Consistency Checker to diagnose inconsistencies between the routing and forwarding tables.

Power Supply Redundancy

The Cisco ASR 9000 Series Routers are configured such that a power module failure or its subsequent replacement does not cause a significant outage. When a power supply failure or over/under voltage at the output of a power module is detected, an alarm is raised.

AC Power Redundancy

The AC power modules are a modular design allowing replacement without any outage. At least one fully loaded AC tray is required to power a fully loaded system. The slot location of a module in the tray is irrelevant as long as there are an equal number of modules (in case one tray fails).



Note AC power redundancy for the Cisco ASR 9010 Router, Cisco ASR 9910 Router, Cisco ASR 9912 Router, and Cisco ASR 9922 Router requires that power modules be installed in multiple power trays.

Cisco ASR 9010 AC Power Redundancy

The Cisco ASR 9010 Router supports the version 1, version 2, and version 3 power systems.

Figure 92: AC System Power Redundancy for the Cisco ASR 9010 Router—Version 1, on page 116 shows the AC power module configuration for the version 1 power system. Figure 93: AC System Power Redundancy for the Cisco ASR 9010 Router—Version 2, on page 116 shows the AC power module configuration for the version 2 power system. Figure 94: AC System Power Redundancy for the Cisco ASR 9010 Router—Version 3, on page 116 show the AC power module configuration for the version 3 power system.

Figure 92: AC System Power Redundancy for the Cisco ASR 9010 Router—Version 1

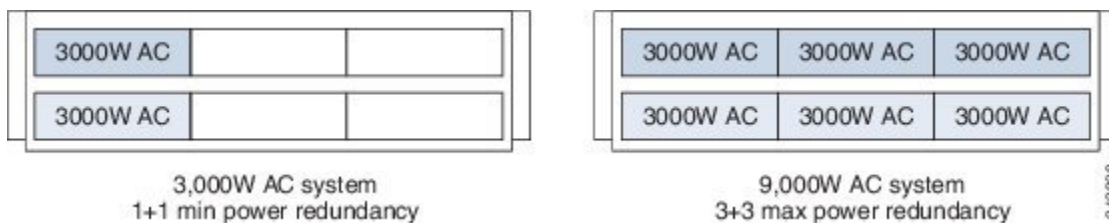


Figure 93: AC System Power Redundancy for the Cisco ASR 9010 Router—Version 2

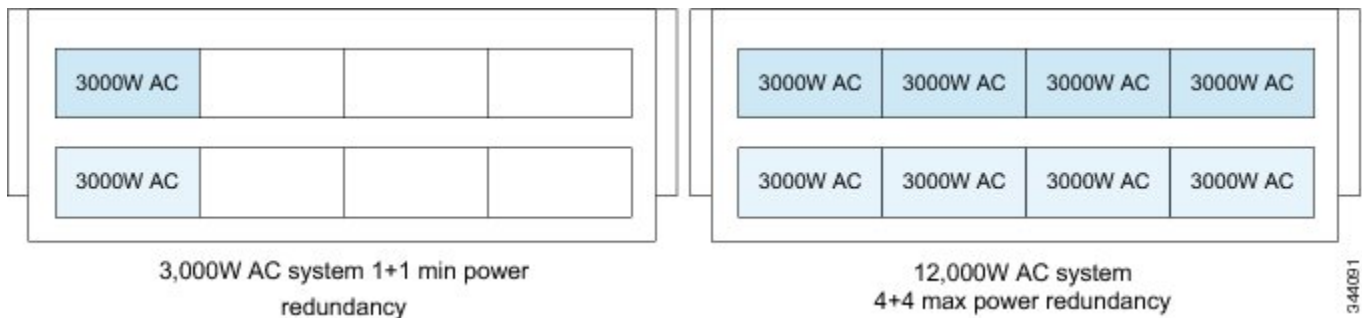


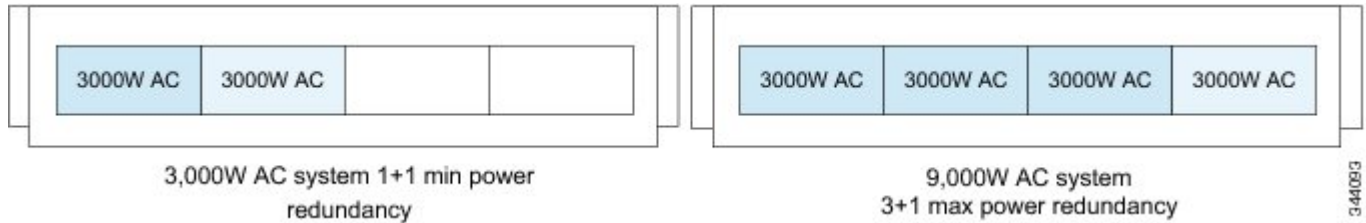
Figure 94: AC System Power Redundancy for the Cisco ASR 9010 Router—Version 3



Cisco ASR 9006 AC Power Redundancy

The Cisco ASR 9006 router supports the version 1 and version 2 power system. The following figure shows an example of the AC power module configuration for the version 2 power system.

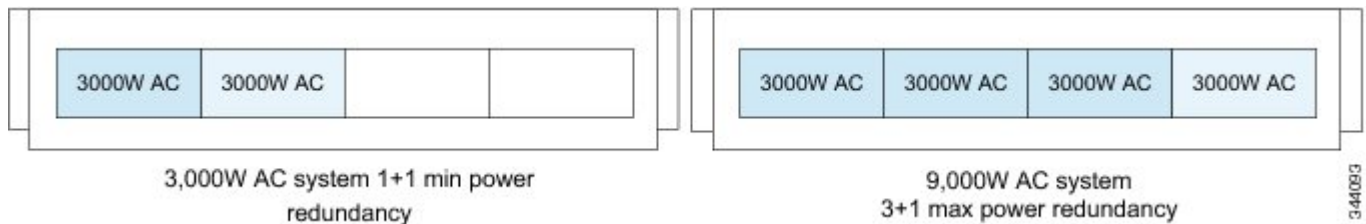
Figure 95: AC System Power Redundancy for the Cisco ASR 9006 Router—Version 2



Cisco ASR 9904 AC Power Redundancy

The Cisco ASR 9904 router supports the version 2 power system. The following figure shows the AC power module configuration for version 2 power system.

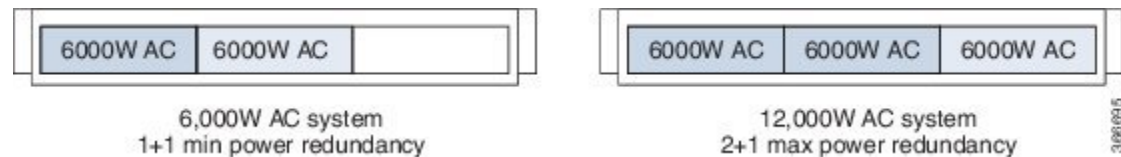
Figure 96: AC System Power Redundancy for the Cisco ASR 9904 Router—Version 2



Cisco ASR 9906 AC Power Redundancy

The Cisco ASR 9906 router supports the version 3 power system. The following figure shows an example of the AC power module configuration for the version 3 power system.

Figure 97: AC System Power Redundancy for the Cisco ASR 9906 Router—Version 3

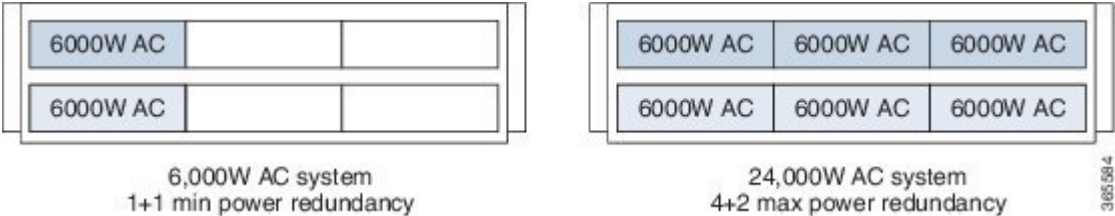


Cisco ASR 9910 AC Power Redundancy

The Cisco ASR 9910 Router supports the version 3 power system.

This figure shows the AC power module configuration for the version 3 power system.

Figure 98: AC System Power Redundancy for the Cisco ASR 9910 Router—Version 3



Cisco ASR 9922 AC Power Redundancy

The Cisco ASR 9922 router supports the version 2 and version 3 power systems. [Figure 99: AC System Power Redundancy for the Cisco ASR 9922 Router—Version 2](#), on page 118 shows the AC power module configuration for the version 2 power system. [Figure 100: AC System Power Redundancy for the Cisco ASR 9922 Router—Version 3](#), on page 119 shows the AC power module configurations for the version 3 power system.

Figure 99: AC System Power Redundancy for the Cisco ASR 9922 Router—Version 2

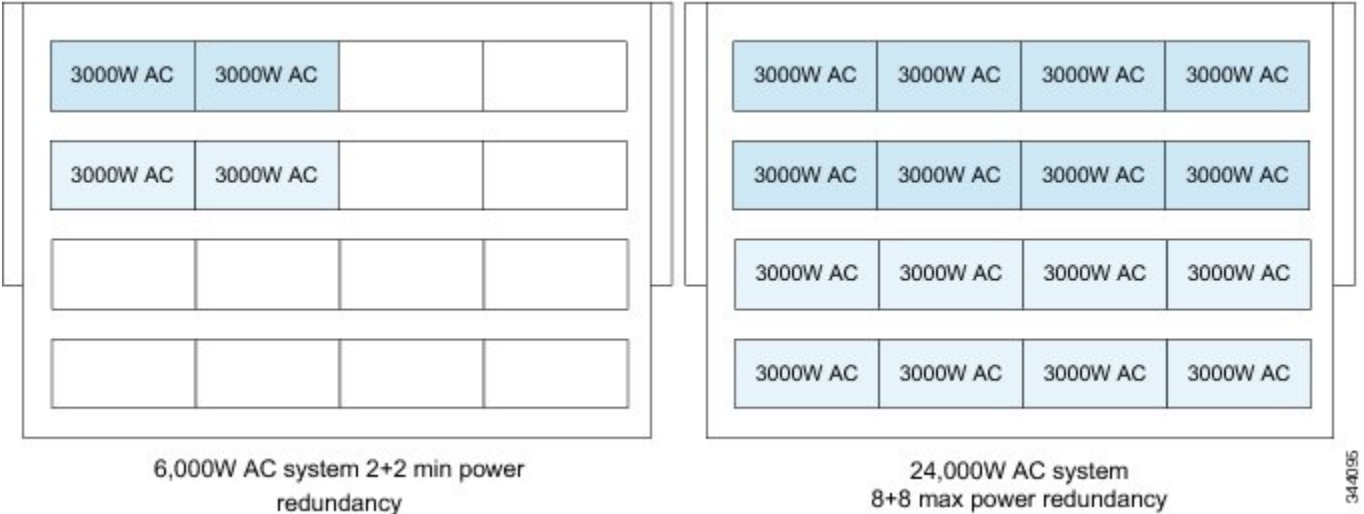
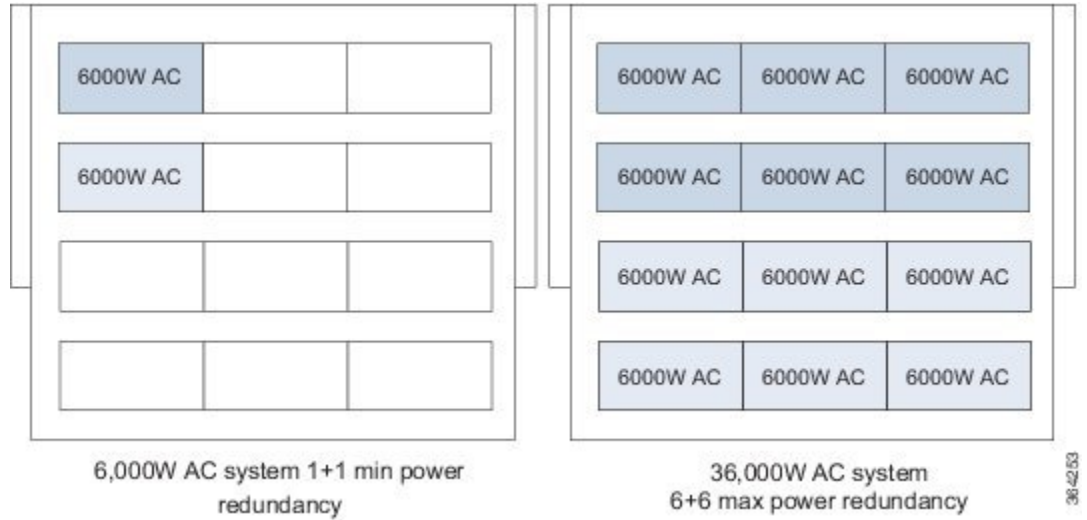


Figure 100: AC System Power Redundancy for the Cisco ASR 9922 Router—Version 3



Cisco ASR 9912 AC Power Redundancy

The Cisco ASR 9912 router supports the version 2 and version 3 power systems. [Figure 101: AC System Power Redundancy for the Cisco ASR 9912 Router—Version 2](#), on page 119 shows the AC power module configuration for the version 2 power system. [Figure 102: AC System Power Redundancy for the Cisco ASR 9912 Router—Version 3](#), on page 120 shows the AC power module configuration for the version 3 power system.

Figure 101: AC System Power Redundancy for the Cisco ASR 9912 Router—Version 2

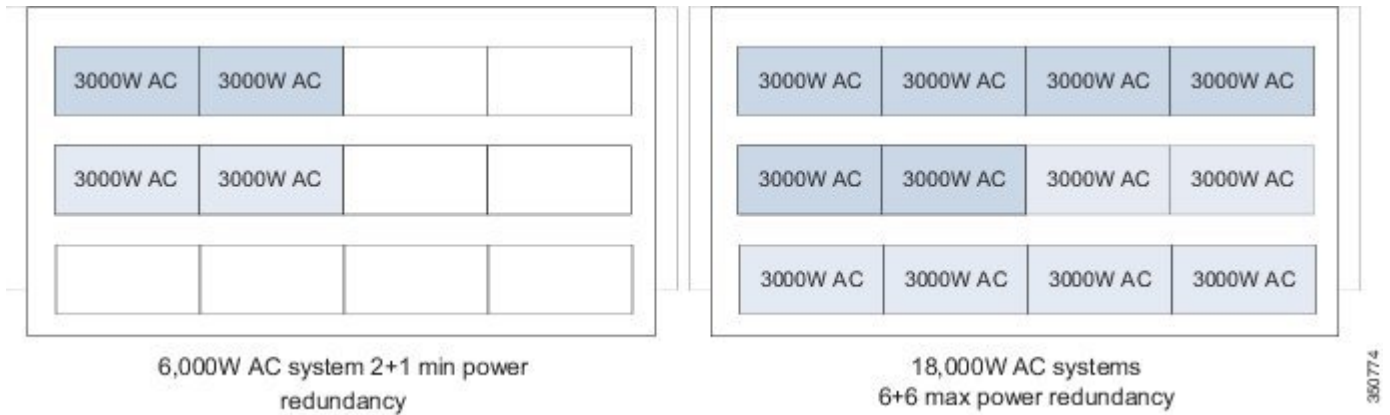
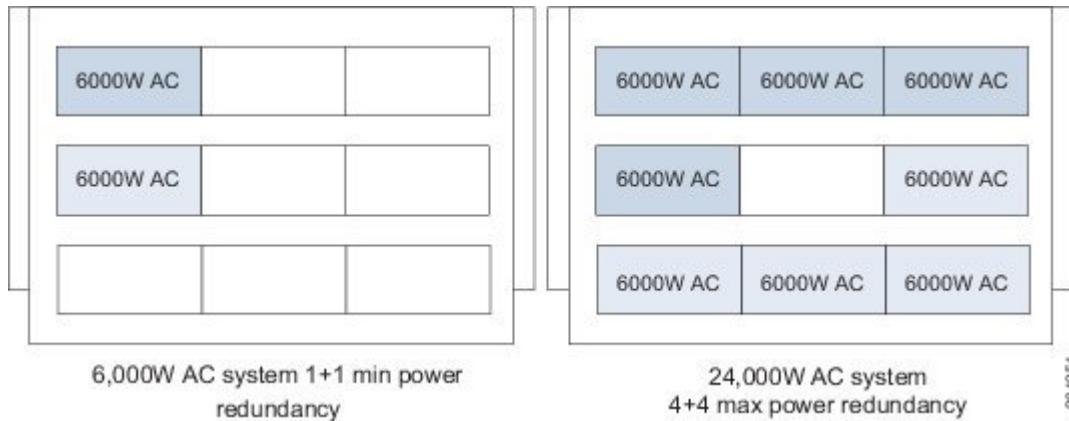


Figure 102: AC System Power Redundancy for the Cisco ASR 9912 Router—Version 3



DC Power Redundancy

The DC power modules are a modular design allowing replacement without any outage. Each tray houses up to three version 1 power modules or four version 2 or version 3 power modules.

The Cisco ASR 9000 Series Routers have three available DC power modules: a 1500 W module, a 2100 W module, and a 4400 W module. All types of power modules can be used in a single chassis. See [Technical Specifications](#) for power module specifications. The slot location of a module in a tray is irrelevant as long as there are N+1 number of modules.

Redundant –48 VDC power feeds are separately routed to each power tray. For maximum diversity, the power entry point to each tray is spatially separated to the left and right edges of the tray. Each feed can support the power consumed by the entire module in version 1 or version 2 modules. There is load sharing between the feeds. Each power module in the tray uses either feed for power, enabling maintenance or replacement of a power feed without causing interruption.

Cisco ASR 9010 DC Power Redundancy

The Cisco ASR 9010 router supports the version 1, version 2, and version 3 power systems.

[Figure 103: DC System Power Redundancy for the Cisco ASR 9010 Router—Version 1](#), on page 120 shows the DC power module configuration for the version 1 power system. [Figure 104: DC System Power Redundancy for the Cisco ASR 9010 Router—Version 2](#), on page 121 shows the DC power module configuration for the version 2 power system. [Figure 105: DC System Power Redundancy for the Cisco ASR 9010 Router—Version 3](#), on page 121 shows the DC power module configuration for the version 3 power system.

Figure 103: DC System Power Redundancy for the Cisco ASR 9010 Router—Version 1

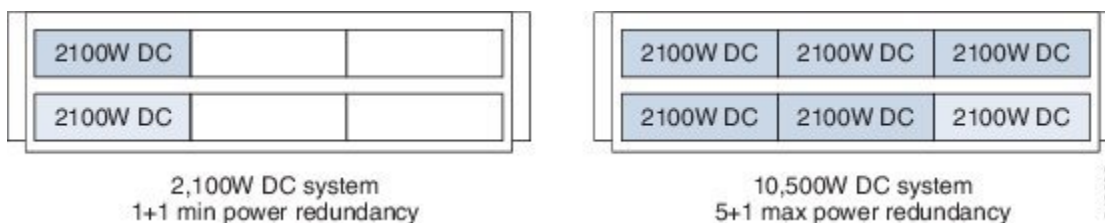


Figure 104: DC System Power Redundancy for the Cisco ASR 9010 Router—Version 2

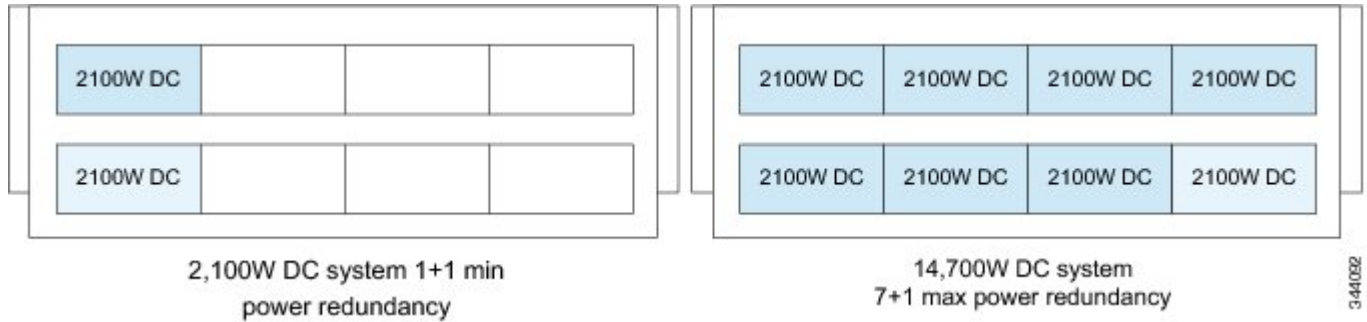
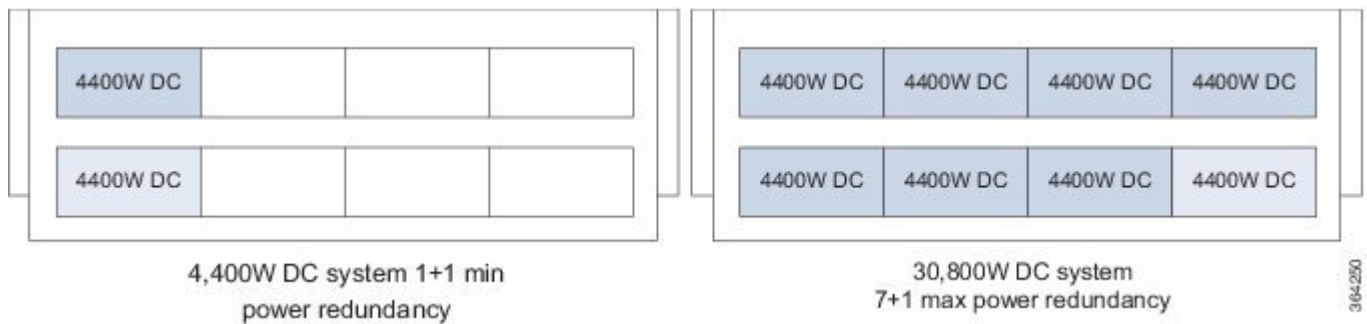


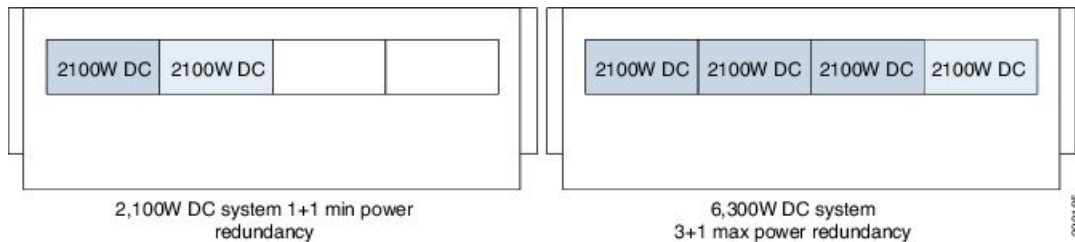
Figure 105: DC System Power Redundancy for the Cisco ASR 9010 Router—Version 3



Cisco ASR 9006 DC Power Redundancy

The Cisco ASR 9006 router supports the version 1 and version 2 power systems. [Figure 106: DC System Power Redundancy for the Cisco ASR 9006 Router—Version 2, on page 121](#) shows an example of the DC power module configuration for the version 2 power system.

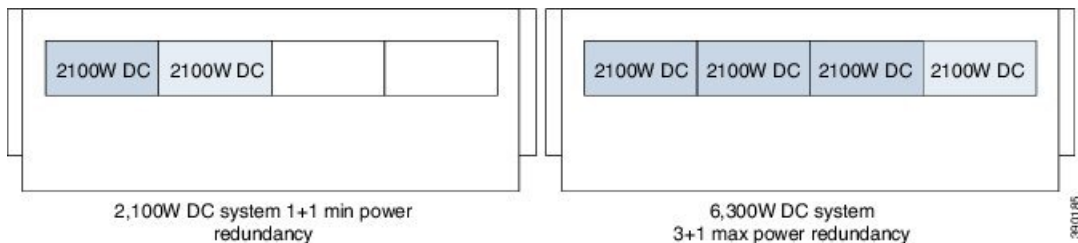
Figure 106: DC System Power Redundancy for the Cisco ASR 9006 Router—Version 2



Cisco ASR 9904 DC Power Redundancy

The Cisco ASR 9904 router supports the version 2 power system. [Figure 107: DC System Power Redundancy for the Cisco ASR 9904 Router—Version 2, on page 122](#) shows the DC power module configuration for the version 2 power system.

Figure 107: DC System Power Redundancy for the Cisco ASR 9904 Router—Version 2



Cisco ASR 9906 DC Power Redundancy

The Cisco ASR 9906 router supports the version 3 power system. The following figure shows the DC power module configuration for the version 3 power system.

Figure 108: DC System Power Redundancy for the Cisco ASR 9906 Router—Version 3



Cisco ASR 9910 DC Power Redundancy

The Cisco ASR 9910 router supports the version 3 power system.

This figure shows the DC power module configuration for the version 3 power system.

Figure 109: DC System Power Redundancy for the Cisco ASR 9910 Router—Version 3



Cisco ASR 9912 DC Power Redundancy

The Cisco ASR 9912 router supports the version 2 and version 3 power systems.

Figure 110: DC System Power Redundancy for the Cisco ASR 9912 Router—Version 2 , on page 123 shows the DC power module configuration for the version 2 power system. Figure 111: DC System Power Redundancy for the Cisco ASR 9912 Router—Version 3, on page 123 shows the DC power module configuration for the version 3 power system.

Figure 110: DC System Power Redundancy for the Cisco ASR 9912 Router—Version 2

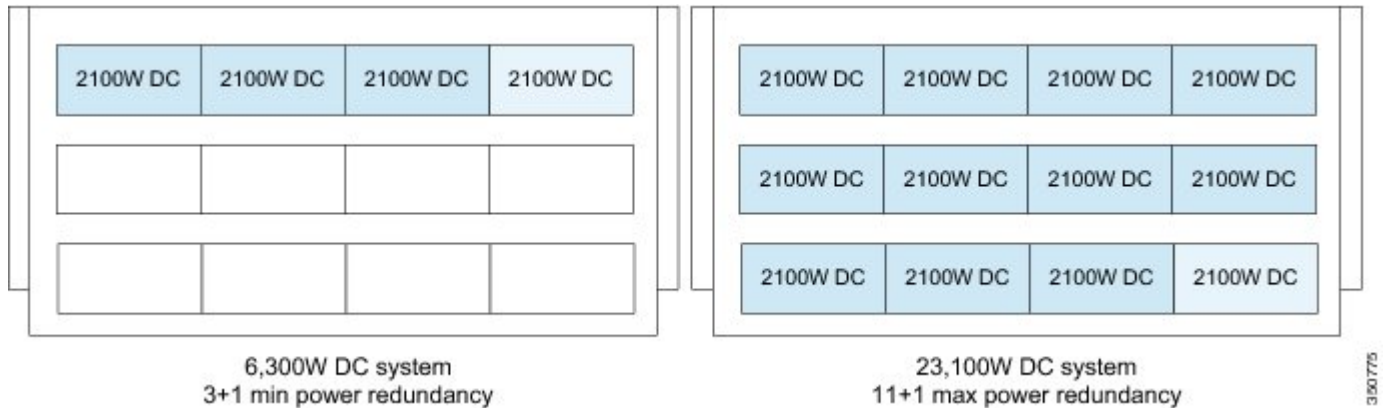
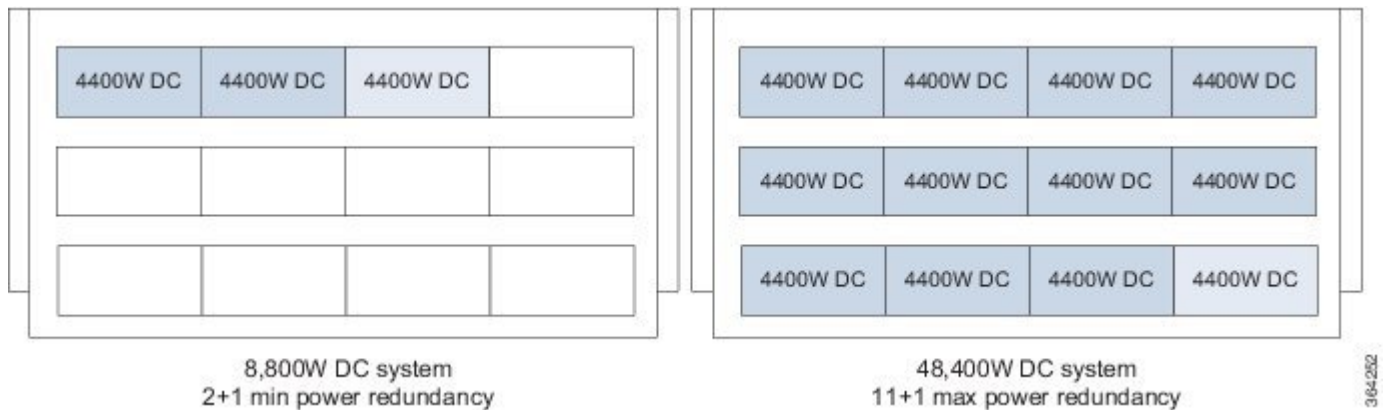


Figure 111: DC System Power Redundancy for the Cisco ASR 9912 Router—Version 3



Note The Cisco ASR 9000 Series Routers are capable of operating with one power module. However, such a configuration does not provide any redundancy.

Cisco ASR 9922 DC Power Redundancy

The Cisco ASR 9922 router supports the version 2 and version 3 power systems.

Figure 112: DC System Power Redundancy for the Cisco ASR 9922 Router—Version 2, on page 124 shows the DC power module configuration for the version 2 power system. Figure 113: DC System Power Redundancy for the Cisco ASR 9922 Router—Version 3, on page 124 shows the DC power module configuration for the version 3 power system.

Figure 112: DC System Power Redundancy for the Cisco ASR 9922 Router—Version 2

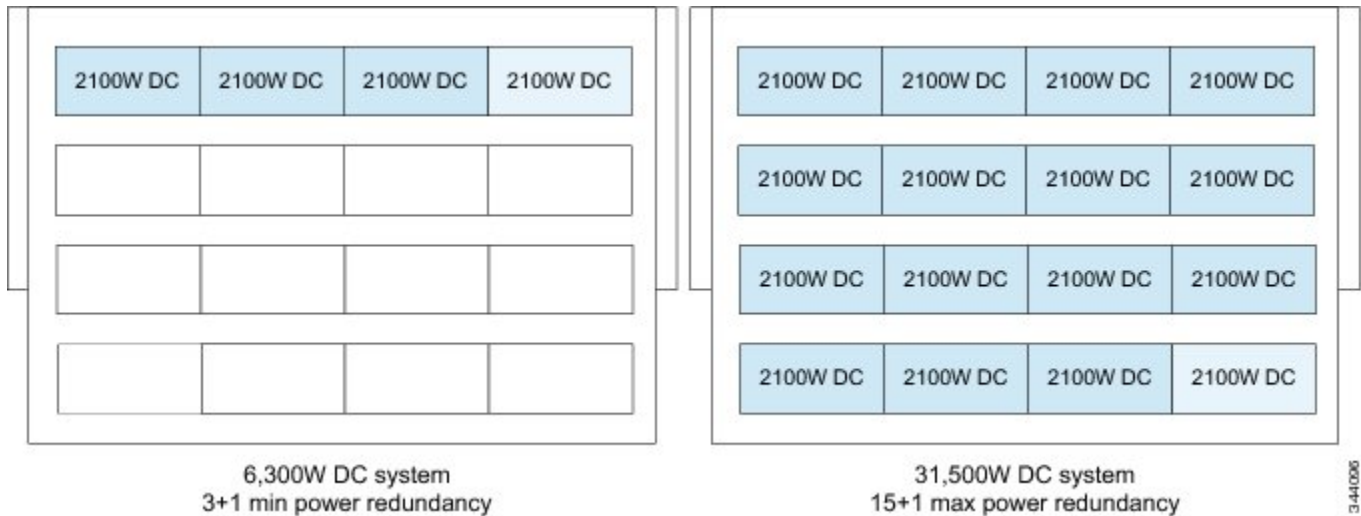
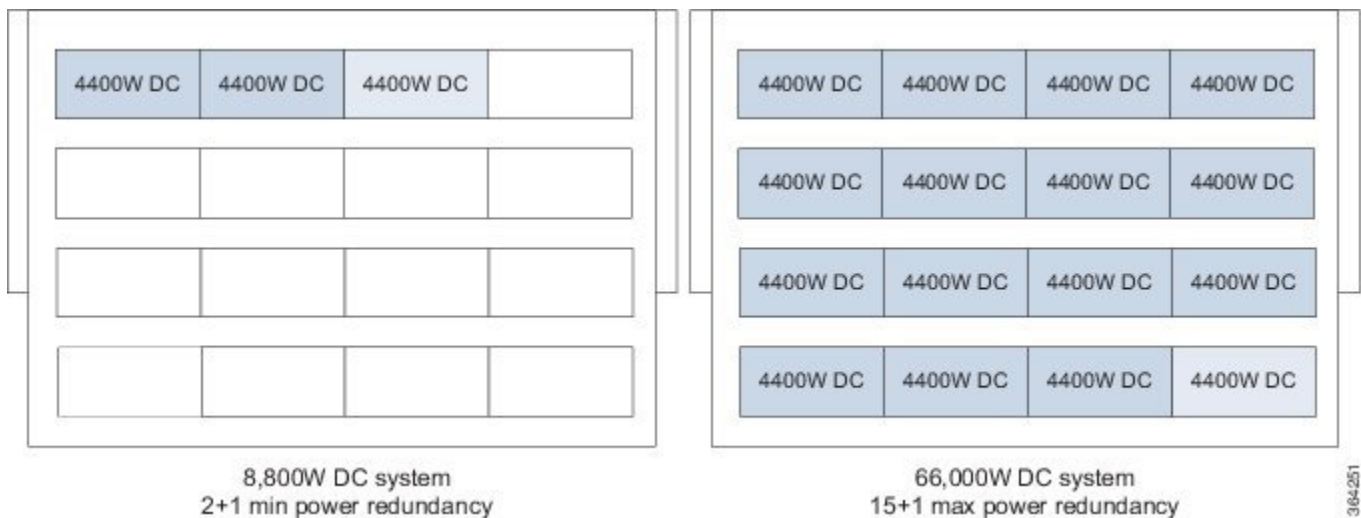


Figure 113: DC System Power Redundancy for the Cisco ASR 9922 Router—Version 3



Detection and Reporting of Power Problems

All –48 VDC feed and return lines have fuses and are monitored. Any fuse blown can be detected and reported. The input voltages are monitored against an over and under voltage alarm threshold.

Cooling System Redundancy

The Cisco ASR 9000 Series Routers are configured in such a way that a fan failure or its subsequent replacement does not cause a significant outage. During either a fan replacement or a fan failure, the airflow is maintained and no outage occurs. Also, the fan trays are hot swappable so that no outage occurs during replacement. For information on redundancy values for the Cisco ASR 9000 Series Routers, see [Table 10: Cisco ASR 9000 Series Routers Fan Tray Locations and Redundancy Information](#).

Cooling Failure Alarm

Temperature sensors are installed in all cards and fan trays. These sensors detect and report any fan failure or high temperature condition, and raise an alarm. Fan failure can be a fan stopping, fan controller failure, power failure, or a failure of a communication link to the RSP/RP card.

Every card has temperature measurement points in the hottest expected area to clearly indicate a cooling failure. The line cards have two sensors, one at the inlet and one near the hottest devices on the card. The RSP/RP card also has two sensors.



CHAPTER 4

Technical Specifications

This appendix lists specifications for the Cisco ASR 9000 Series Aggregation Services Routers.

- [Cisco ASR 9000 Series Routers Physical Descriptions, on page 127](#)
- [Cisco ASR 9000 Series Routers Environmental Specifications, on page 129](#)
- [Cisco ASR 9000 Series Routers AC Electrical Specifications, on page 130](#)
- [Cisco ASR 9000 Series Routers DC Electrical Specifications, on page 132](#)
- [AC Input and DC Input Voltage Range, on page 134](#)
- [Power System DC Output Levels, on page 134](#)
- [RSP/RP Port Specifications, on page 136](#)
- [RSP, RP, FC Power Consumption Specifications, on page 137](#)
- [Fan Tray Power Consumption Specifications, on page 139](#)

Cisco ASR 9000 Series Routers Physical Descriptions

Table 13: Cisco ASR 9000 Series Routers Physical Descriptions

Router	Chassis Height	Chassis Width	Chassis Depth	Chassis Weight ¹
Cisco ASR 9010 Router	36.75 inches (93.35 cm)	17.50 inches (44.45 cm) 19.0 inches (48.3 cm) including chassis rack-mount flanges and front door width	28.65 inches (72.72 cm) including the cable management system and front cover	Chassis only – 149.5 pounds (67.81 kg) Chassis: fully configured using all card slots and six power modules – 375 pounds (170.5 kg)
Cisco ASR 9006 Router	17.50 inches (44.45 cm)	17.50 inches (44.45 cm) 19.0 inches (48.3 cm) including chassis rack-mount flanges and front door width	28.93 inches (73.48 cm) from the rear cover to the front of the cosmetic doors	Chassis only – 87.5 pounds (39.69 kg) Chassis: fully configured using all card slots and six power modules – 230 pounds (104.33 kg)

Router	Chassis Height	Chassis Width	Chassis Depth	Chassis Weight ¹
Cisco ASR 9904 Router	10.38 inches (26.36 cm)	17.75 inches (45.08 cm) 19.0 inches (48.3 cm) including chassis rack-mount flanges	28.56 inches (72.53 cm) from the cable management system to the tip of the fan tray handle	Chassis only – 43.3 pounds (19.64 kg) Chassis: fully configured using all card slots and four power modules – 122.8 pounds (55.70 kg)
Cisco ASR 9906 Router	24.39 inches (61.95 cm)	17.6 inches (44.7 cm)	28.77 inches (73.08 cm) 31.45 inches (79.88 cm) including the cable management system	Chassis only – 108.02 pounds (49 kg) Chassis: Configured with two fan trays, two RSPs, five fabric cards, and one PEM – 251.10 pounds (113.9 kg)
Cisco ASR 9910 Router	36.70 inches (93.28 cm)	17.6 inches (44.70 cm) including chassis rack-mount flanges and front door width	31.50 inches (80.01 cm) including the cable management system and front cover	Chassis only – 143.11 pounds (64.915 kg) Chassis: Configured with two fan trays, two RSPs, five fabric cards, and one PEM – 349.59 pounds (158.575 kg)
Cisco ASR 9912 Router	52.5 inches (133.4 cm)	17.6 inches (44.7 cm) 19.0 inches (48.3 cm) including chassis rack-mount flanges and front doors	25.7 inches (65.2 cm) 29.4 inches (74.7 cm) including the cable management system 30.1 inches (76.4 cm) including cable management system and front doors	Chassis only – 181 pounds (82.10 kg) Chassis: fully configured using all card slots and three power trays – 643 pounds (291.66 kg)
Cisco ASR 9922 Router	77.00 inches (195.58 cm)	17.60 inches (44.70 cm) 19.0 inches (48.3 cm) including chassis rack-mount flanges and front door width	26.3 inches (66.82 cm) 30.00 inches (76.20 cm) including the cable management system 30.62 inches (77.77 cm) with front doors	Chassis only – 300 pounds (136 kg) Chassis: fully configured using all card slots and four power modules – 1038 pounds (470.28 kg)

¹ Chassis only does not include cards, power modules, fan trays, filter, or chassis accessories.

Cisco ASR 9000 Series Routers Environmental Specifications

Table 14: Cisco ASR 9000 Series Routers Environmental Specifications

Description	Value
Operating Temperature: ²	41 to 104°F (5 to 40°C)
Operating Temperature, ³ (Short term) ^{4,5}	23 to 131° F (-5° to 55°C) for Cisco ASR 9006 Router, Cisco ASR 9906 Router, and Cisco ASR 9904 Router 23 to 122° F (-5° to 50°C) for Cisco ASR 9010 Router, Cisco ASR 9922 Router, Cisco ASR 9910 Router, and Cisco ASR 9912 Router
Non-operating Temperature	-40 to 158°F (-40 to 70°C)
Humidity	Operating: 10 to 85 percent noncondensing Non-operating: 5 to 95 percent noncondensing
Altitude ⁶	Operating: 0 to 13,000 ft. (0 to 4,000 m) Non-operating: 0 to 15,000 ft (0 to 4,570 m) 16-port 10-Gigabit Ethernet line card: 0 to 5,904 ft (0 to 1,800 m)
Power Dissipation	All Cisco ASR 9000 Series Routers Use the Cisco Power Calculator (Cisco.com account required) at http://tools.cisco.com/cpc/launch.jsp to estimate the maximum power distribution.
Acoustic noise	78 dB at 80.6°F (27°C) maximum
Shock	Operating (halfsine): 21 in/sec (0.53 m/sec.) Non-operating (trapezoidal pulse): 20 G ⁷ , 52 in/sec (1.32 m/sec)
Vibration	Operating: 0.35 Grms ⁸ from 3 to 500 Hz Non-operating: 1.0 Grms from 3 to 500 Hz

² Operating temperature specifications for the router will differ from those listed in this table when 40-port Gigabit Ethernet line cards using GLC-GE-100FX SFP transceiver modules are installed in the router. This is due to the lower temperature specifications of the SFP module. Please contact a Cisco representative for more information.

³ Short term operating temperature specifications for the router will differ from those listed in this table when the 16-port 10-Gigabit Ethernet line card is installed in the router because of the lower temperature specifications of the SFP+ modules and that are used in this line card. When using this line card, the maximum operating temperature is 104°F (40°C).

⁴ Short-term refers to a period of not more than 96 consecutive hours and a total of no more than 15 days in 1 year. (This refers to a total of 360 hours in any given year, but no more than 15 occurrences during that 1-year period.).

⁵ The 24 port 10 Gigabit Ethernet linecard requires high temperature optics to run in the extended temperature range.

⁶ Operating altitude specifications for the router will differ from those listed in this table when the 16-port 10-Gigabit Ethernet line card is installed in the router. When using the SFP-10G-SR module, the maximum altitude is 5905 ft. (1800 m). When using the SFP-10G-LR or SFP-10G-ER modules, the maximum altitude is sea level.

⁷ G is a value of acceleration, where 1 G equals 32.17 ft./sec² (9.81 m/sec²).

⁸ Grms is the root mean square value of acceleration.

Cisco ASR 9000 Series Routers AC Electrical Specifications

Table 15: Cisco ASR 9000 Series Routers AC Electrical Specifications

Description	ASR 9010	ASR 9006	ASR 9904	ASR 9922
Power modules per system	Version 1 power system: Up to six AC power modules per system, three per tray Version 2 power system: Up to eight AC power modules per system, four per tray Version 3 power system: Up to six AC power modules per system, three per tray	Version 1 power system: Up to three AC power modules per system Version 2 power system: Up to four AC power modules per system Note The ASR 9006 chassis does not support version 3 power modules.	Version 2 power system: Up to four AC power modules per system	Version 2 power system: Up to sixteen AC power modules per system, four per tray Version 3 power system: Up to twelve AC power modules per system, three per tray
Total AC input power per power module	Version 2 power system: 3290 VA (3000 W output module) Version 3 power system: 6510 VA (6000 W output module)	Version 1 power system: 3400 VA (volt-amps) per AC power module Version 2 power system: 3290 VA (3000 W output module)	Version 2 power system: 3290 VA (3000 W output module)	Version 2 power system: 3290 VA (3000 W output module) Version 3 power system: 6510 VA (6000 W output module)
Rated input voltage per power module ²	200–240 VAC nominal (range: 180 to 264 VAC) 220–240 VAC (UK)			
Rated input line frequency ¹	50/60 Hz nominal (range: 47 to 63 Hz) 50/60 Hz (UK)			
Input current draw ¹	15 A maximum at 200 VAC 13 A maximum at 220 to 240 VRMS (UK)			
Source AC service requirement ¹	20 A North America; 16 A international; 13 A United Kingdom			

Description	ASR 9010	ASR 9006	ASR 9904	ASR 9922
Redundancy	AC power modules operate in N+N redundancy mode ¹⁰	At least two AC power modules required for N+1 redundancy for a fully configured system	At least two AC power modules required for N+1 redundancy for a fully configured system	AC power modules operate in N+N redundancy mode ²

⁹ For each AC power supply module. Some power/chassis configurations may operate at lower current ratings than those specified in this table. Contact your Cisco technical representative for more information.

¹⁰ The number of AC power modules needed depends on the configuration of the chassis (e.g. number of line cards, RPs, and FC cards installed). Use the Cisco Power Calculator (Cisco.com account required) at <http://tools.cisco.com/cpc/launch.jsp> to calculate how many AC power modules are needed.



Caution Be sure that the chassis configuration complies with the required power budgets. Failure to properly verify the configuration may result in an unpredictable state if one of the power units fails. Contact your local sales representative for assistance.

Description	ASR 9906	ASR 9910	ASR 9912
Power modules per system	Version 3 power system: Up to three AC power modules per system	Version 3 power system: Up to six AC power modules per system, three per tray	Version 2 power system: Up to twelve AC power modules per system, four per tray Version 3 power system: Up to nine AC power modules per system, three per tray
Total AC input power per power module	Version 3 power system: 6510 VA (6000 W output module)	Version 3 power system: 6510 VA (6000 W output module)	Version 2 power system: 3290 VA (3000 W output module) Version 3 power system: 6510 VA (6000 W output module)
Rated input voltage per power module	200–240 VAC nominal (range: 180 to 264 VAC) 220–240 VAC (UK)		
Rated input line frequency	50/60 Hz nominal (range: 47 to 63 Hz) 50/60 Hz (UK)		
Input current draw	15 A maximum at 200 VAC 13 A maximum at 220 to 240 VRMS (UK)		
Source AC service requirement	20 A North America; 16 A international; 13 A United Kingdom		

Description	ASR 9906	ASR 9910	ASR 9912
Redundancy	At least two AC power modules required for N+1 redundancy for a fully configured system	AC power modules operate in N+N redundancy mode ¹¹	

¹¹ The number of AC power modules needed depends on the configuration of the chassis (e.g. number of line cards, RPs, and FC cards installed). Use the Cisco Power Calculator (Cisco.com account required) at <http://tools.cisco.com/cpc/launch.jsp> to calculate how many AC power modules are needed.

Cisco ASR 9000 Series Routers DC Electrical Specifications

Table 16: Cisco ASR 9000 Series Routers DC Electrical Specifications

Description	ASR 9010	ASR 9006	ASR 9904	ASR 9922
Power modules per system	Version 1 power system: Up to six DC power module per system, three per tray Version 2 power system: Up to eight DC power modules per system, four per tray Version 3 power system: Up to eight DC power modules per system, four per tray	Version 1 power system: Up to three DC power modules per system Version 2 power system: Up to four DC power modules per system	Version 2 power system: Up to four DC power modules per system	Version 2 power system: Up to sixteen DC power modules per system, four per tray Version 3 power system: Up to sixteen DC power modules per system, four per tray
Total DC input power per power module	Version 1 power system: 1700 W (1500 W output module) Version 2 power system: 2340 W (2100 W output module) Version 3 power system: 4730 W (4400 W output module)	Version 1 power system: 1700 W (1500 W output module) Version 2 power system: 2300 W (2100 W output module)	Version 2 power system: 2300 W (2100 W output module)	Version 2 power system: 2340 W (2100 W output module) Version 3 power system: 4730 W (4400 W output module)
Rated input voltage per power module	–48 VDC nominal in North America –60 VDC nominal in the European Community (Range: –40.5 to –72 VDC [–75 VDC for 5 ms])			
Rated input current draw	49 A maximum at –48 VDC nominal 39 A maximum at –60 VDC nominal			
Source DC service requirement ¹²	Sufficient to supply the rated input current. Local codes apply.			

Description	ASR 9010	ASR 9006	ASR 9904	ASR 9922
Redundancy	DC power modules operate in N+1 redundancy mode ¹³	At least two DC power modules are required for N+1 redundancy for a fully configured system	At least two DC power modules are required for N+1 redundancy for a fully configured system	DC power modules operate in N+1 redundancy mode2

¹² For each DC power supply module. Some power/chassis configurations may operate at lower current ratings than those specified in this table. Contact your Cisco technical representative for more information.

¹³ The number of DC power modules needed depends on the configuration of the chassis (e.g. number of line cards, RPs, and FC cards installed). Use the Cisco Power Calculator (Cisco.com account required) at <http://tools.cisco.com/cpc/launch.jsp> to calculate how many AC power modules are needed.

Description	ASR 9906	ASR 9910	ASR 9912
Power modules per system	Version 3 power system: Up to four DC power modules per system	Version 3 power system: Up to eight DC power modules per system, four per tray	Version 2 power system: Up to twelve DC power modules per system, four per tray Version 3 power system: Up to twelve DC power modules per system, four per tray
Total DC input power per power module	Version 3 power system: 4730 W (4400 W output module)	Version 3 power system: 4730 W (4400 W output module)	Version 2 power system: 2340 W (2100 W output module) Version 3 power system: 4730 W (4400 W output module)
Rated input voltage per power module	-48 VDC nominal in North America -60 VDC nominal in the European Community (Range: -40.5 to -72 VDC [-75 VDC for 5 ms])		
Rated input current draw	49 A maximum at -48 VDC nominal 39 A maximum at -60 VDC nominal		
Source DC service requirement ¹⁴	Sufficient to supply the rated input current. Local codes apply.		
Redundancy	DC power modules operate in N+1 redundancy mode	DC power modules operate in N+3 redundancy mode ¹⁵	DC power modules operate in N+1 redundancy mode2

¹⁴ For each DC power supply module. Some power/chassis configurations may operate at lower current ratings than those specified in this table. Contact your Cisco technical representative for more information

¹⁵ The number of DC power modules needed depends on the configuration of the chassis (e.g. number of line cards, RPs, and FC cards installed). Use the Cisco Power Calculator (Cisco.com account required) at <http://tools.cisco.com/cpc/launch.jsp> to calculate how many AC power modules are needed



Caution While performing a FPD upgrade of the ASR 9000 6kW AC Power Module Version 3 (PWR-6KW-AC-V3) and the ASR 9000 4.4kW DC Power Module Version 3 (PWR-4.4KW-DC-V3), ensure that you connect both input power cords to the power supply. If the power cords are not connected, the FPD upgrade for the power module will fail.

AC Input and DC Input Voltage Range

AC Input Voltage Range

Table 17: AC Input Voltage Range (Single-Phase Power Source)

Range	Minimum	Minimum Nominal	Nominal	Maximum Nominal	Maximum
Input Voltage	180 VAC	200 VAC	220 VAC	240 VAC	264 VAC
Line Frequency	47 Hz	50 Hz	50/60 Hz	60 Hz	63 Hz

DC Input Voltage Range

Table 18: DC Input Voltage Range

Range	Minimum	Nominal	Maximum
Input Voltage	-40 VDC	-48 VDC	-72 VDC

Power System DC Output Levels

DC Output Levels for Version 1 Power System

Table 19: DC Output Levels for Version 1 Power System

Parameter	Value
Voltage	
Maximum	-54.5 VDC
Nominal	-54.0 VDC

Parameter	Value
Minimum	-53.5 VDC
Power	
Minimum (one power module)	1500 W
Maximum (three 2100 W power modules per tray x two trays)	12,600 W (Cisco ASR 9010 Router only) ¹⁶
Maximum (three 2100 W power modules in a single tray)	6300 W (Cisco ASR 9006 Router only)

¹⁶ Maximum output power the power system is capable of supporting (not system power consumption).

DC Output Levels for Version 2 Power System

Table 20: DC Output Levels for Version 2 Power System

Parameter	Value
Voltage	
Maximum	-55.5 VDC
Nominal	-54.0 VDC
Minimum	-52.5 VDC
Power	
Minimum (one power module)	2100 W
Maximum (four 2100 W DC power modules or 3000 W AC power modules in a single tray) ¹⁷	8400 W (DC) 12,000 W (AC) Cisco ASR 9006 Router and Cisco ASR 9904 Router
Maximum (four 2100 W DC power modules or 3000 W AC power modules per tray x two trays)	16,800 W (DC) 24,000 W (AC) (Cisco ASR 9010 Router only)
Maximum (four 2100 W DC power modules or 3000 W AC power modules per tray x four trays)	33,600 W (DC) 48,000 W (AC) (Cisco ASR 9922 Router only)

¹⁷ Maximum output power the power system is capable of supporting (not system power consumption).

DC Output Levels for Version 3 Power System

Table 21: DC Output Levels for Version 3 Power System

Parameter	Value
Voltage	

Parameter	Value
Maximum	-55.5 VDC
Nominal	-54.0 VDC
Minimum	-52.5 VDC
Power	
Minimum (one power module)	4400 W
Maximum (four 4400 W DC power modules or three 6000 W AC power modules per single tray) ¹⁸	17,600 W (DC) 18,000 W (AC) (Cisco ASR 9906 Router only)
Maximum (four 4400 W DC power modules or three 6000 W AC power modules per tray x two trays) ¹⁹	35,200 W (DC) 36,000 W (AC) (Cisco ASR 9010 Router only)
Maximum (four 4400 W power modules or three 6000 W AC power modules per tray x three trays)	52,800 W (DC) 54,000 W (AC) (Cisco ASR 9912 Router only)
Maximum (four 4400 W power modules or three 6000 W AC power modules per tray x four trays)	70,400 W (DC) 72,000 W (AC) (Cisco ASR 9922 Router only)

¹⁸ Maximum output power the power system is capable of supporting (not system power consumption).

¹⁹ Maximum output power the power system is capable of supporting (not system power consumption).

RSP/RP Port Specifications

Table 22: RSP/RP Port Specifications

Description	Value
Console port	EIA/TIA-232 RJ-45 interface. The default port speeds are: <ul style="list-style-type: none"> • 115200 Baud, 8 data, no parity, 2 stop bits with flow control none for the RP2 card on the Cisco ASR 9922 Router and the Cisco ASR 9912 Router • 9600 Baud, 8 data, no parity, 2 stop bits with flow control none for all other RSP/RP cards
Auxiliary port	EIA/TIA-232 RJ-45 interface, 9600 Baud, 8 data, no parity, 1 stop bit with software handshake (default)
Management ports (0, 1)	Dual-speed (100M/1000M) RJ-45
Sync ports (0, 1)	Can be configured as one of the following: <ul style="list-style-type: none"> • BITS (Building Integrated Timing System) port • J.211 or UTI (Universal Timing Interface) port

RSP, RP, FC Power Consumption Specifications

The following table lists the power consumption specifications for the RSP cards, RP cards, and fabric cards (FCs). For power consumption values for the Ethernet line cards, see the [Cisco ASR 9000 Series Aggregation Services Router Ethernet Line Card Installation Guide](#).



Caution Be sure that the chassis configuration complies with the required power budgets. Failure to properly verify the configuration may result in an unpredictable state if one of the power units fails.

Table 23: RSP Cards, RP Cards, Fabric Cards Power Consumption Specifications

Card	Power Consumption
RSP Card	175 W at 77°F (25°C) 205 W at 104°F (40°C) 235 W at 131°F (55°C)
RSP-440 Card	285 W at 77°F (25°C) 350 W at 104°F (40°C) 370 W at 131°F (55°C)
RSP-440 Lite Card	240 W at 77°F (25°C) 270 W at 104°F (40°C) 300 W at 131°F (55°C)
RSP-880 Card	425 W at 81°F (27°C) 430 W at 104°F (40°C) 450 W at 131°F (55°C)
RSP880-LT Card	285 W at 81°F (27°C) 295 W at 104°F (40°C) 315 W at 131°F (55°C)
RSP4-S Card (ASR 9910)	310 W at 81°F (27°C) 310 W at 104°F (40°C) 370 W at 131°F (55°C)
RSP5 Card	470 W at 81°F (27°C) 480 W at 104°F (40°C) 490 W at 131°F (55°C)

Card	Power Consumption
RP Card	227 W at 77°F (25°C) 251 W at 104°F (40°C) 259 W at 131°F (55°C)
RP2 Card	390 at 81°F (27°C) 400 at 104°F (40°C) 410 at 131°F (55°C)
RP3 Card	260 W at 81°F (27°C) 275 W at 104°F (40°C) 285 W at 131°F (55°C)
FC Card (ASR 9922)	135 W at 77°F (25°C) 147 W at 104°F (40°C) 160 W at 131°F (55°C)
FC2 Card (ASR 9922)	155 W at 81°F (27°C) 160 at 104°F (40°C) 165 at 131°F (55°C)
A99-SFC3 Card (ASR 9922)	320 W at 81°F (27°C) 330 at 104°F (40°C) 340 at 131°F (55°C)
FC Card (ASR 9912)	80 W at 77°F (25°C) 82 W at 104°F (40°C) 88 W at 131°F (55°C)
FC2 Card (ASR 9912)	94 W at 81°F (27°C) 103 W at 104°F (40°C) 105 W at 131°F (55°C)
A99-SFC3 Card (ASR 9912)	165 W at 81°F (27°C) 175 W at 104°F (40°C) 185 W at 131°F (55°C)
SFC-T Card (ASR 9906)	75 W at 81°F (27°C) 75 W at 104°F (40°C) 85 W at 131°F (55°C)

Card	Power Consumption
A99-SFC3-S Card	150 W at 81°F (27°C)
	160 W at 104°F (40°C)
	170 W at 131°F (55°C)
A99-SFC3-T Card	105 W at 81°F (27°C)
	108 W at 104°F (40°C)
	110 W at 131°F (55°C)

Fan Tray Power Consumption Specifications



Note The fan tray power consumption numbers reflect the power budget for a single fan tray

Table 24: Fan Tray Power Consumption Specifications

Description	Power Consumption
ASR 9010 Fan Tray V1	200 W at 77°F (25°C)
	300 W at 104°F (40°C)
	600 W at 131°F (55°C)
ASR 9010 Fan Tray V2	240 W at 77°F (25°C)
	960 W at 104°F (40°C)
	1100 W at 131°F (55°C)
ASR 9006 Fan Tray V2	100 W at 77°F (25°C)
	275 W at 104°F (40°C)
	375 W at 131°F (55°C)
ASR 9904 Fan Tray V2	100 W at 77°F (25°C)
	360 W at 104°F (40°C)
	605 W at 131°F (55°C)
ASR 9922 Fan Tray V2	200 W at 77°F (25°C)
	870 W at 104°F (40°C)
	1000 W at 131°F (55°C)

Description	Power Consumption
ASR 9922 Fan Tray V3	500 W at 77°F (25°C) 1200 W at 104°F (40°C) 2800 W at 131°F (55°C)
ASR 9912 Fan Tray V2	290 W at 77°F (25°C) 900 W at 104°F (40°C) 1800 W at 131°F (55°C)
ASR 9910 Fan Tray	450 W at 77°F (25°C) 900 W at 104°F (40°C) 3000 W at 131°F (55°C)
ASR 9906 Fan Tray	50 W at 77°F (25°C) 300 W at 104°F (40°C) 750 W at 131°F (55°C)