

# Configurando RADIUS AAA básico para clientes de discagem

## Contents

[Introduction](#)

[Prerequisites](#)

[Requirements](#)

[Componentes Utilizados](#)

[Conventions](#)

[Configurar](#)

[Diagrama de Rede](#)

[Configurações](#)

[Verificar](#)

[Exemplo de saída de show](#)

[Troubleshoot](#)

[Comandos para Troubleshooting](#)

[Exemplo de saída de depuração](#)

[Informações Relacionadas](#)

## [Introduction](#)

Este documento descreve uma configuração de exemplo usando um servidor de acesso para aceitar conexões analógicas e ISDN de entrada e autenticá-las usando um servidor de Serviço de Usuário de Autenticação Remota de Autenticação Remota (RADIUS - Remote Authentication Dial-in User Service) de autenticação, autorização e contabilização (AAA - Remote Authentication Dial-in User Service). Para obter mais informações sobre AAA e RADIUS, consulte os seguintes documentos:

- [Configurando o RADIUS](#)
- [Configurando AAA básico em um servidor de acesso](#)

## [Prerequisites](#)

## [Requirements](#)

Esta configuração pressupõe que o servidor RADIUS está configurado corretamente. Essa configuração também funciona com a maioria dos servidores RADIUS disponíveis comercialmente. Consulte a documentação do servidor RADIUS para obter mais informações sobre a configuração adequada do servidor.

## [Componentes Utilizados](#)

As informações neste documento são baseadas nas versões de software e hardware abaixo.

- Cisco AS5300 com T1 PRI e 48 modems digitais. Ele está executando o software Cisco IOS® versão 12.0(7)T.
- Servidor CiscoSecure para Unix (CSU), versão 2.3(3).

A configuração específica de AAA descrita aqui também pode ser usada com qualquer cenário de discagem simples. Certifique-se de que o servidor de acesso possa aceitar chamadas recebidas e adicione os comandos AAA apropriados, conforme mostrado na configuração abaixo.

As informações neste documento foram criadas a partir de dispositivos em um ambiente de laboratório específico. All of the devices used in this document started with a cleared (default) configuration. Se você estiver trabalhando em uma rede ativa, certifique-se de que entende o impacto potencial de qualquer comando antes de utilizá-lo.

## Conventions

Para obter mais informações sobre convenções de documento, consulte as [Convenções de dicas técnicas Cisco](#).

## Configurar

Nesta seção, você encontrará informações para configurar os recursos descritos neste documento.

**Observação:** para encontrar informações adicionais sobre os comandos usados neste documento, use a [ferramenta Command Lookup Tool](#) (somente clientes [registrados](#)).

## Diagrama de Rede

Este documento utiliza a instalação de rede mostrada no diagrama abaixo.

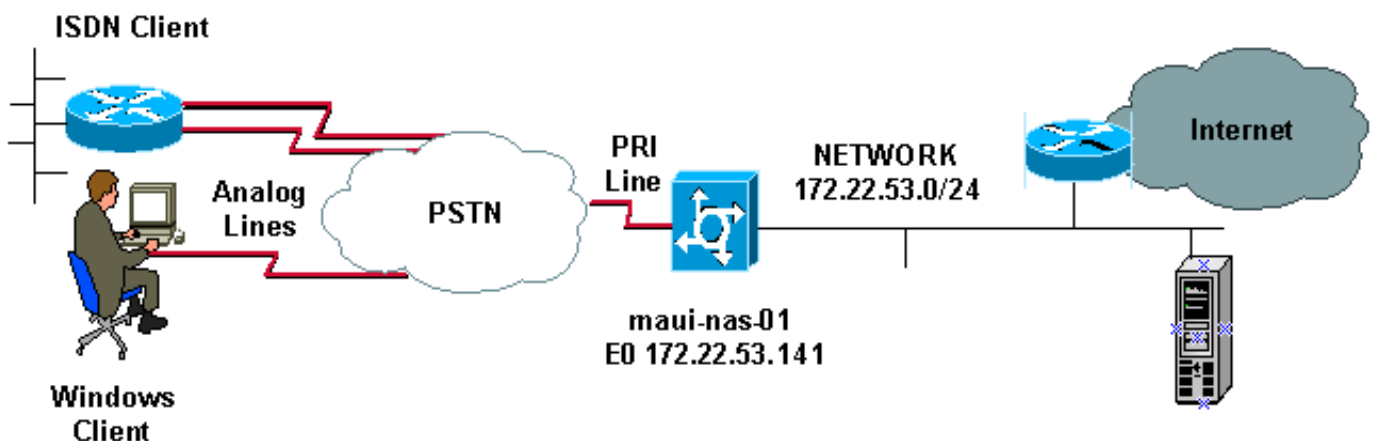

## Configurações

A configuração CSU e Cisco Secure NT (CSNT) e a configuração do servidor de acesso à rede (NAS) são fornecidas abaixo. Como essa configuração representa um cenário de discagem simples, a configuração do CiscoSecure para os usuários ISDN e assíncrono é idêntica. A configuração do cliente ISDN não está incluída, pois não é relevante para essa configuração

## RADIUS.

```
CSU

# ./ViewProfile -p 9900 -u async_client
User Profile Information
user = async_client{
profile_id = 110
profile_cycle = 2
radius=Cisco {
check_items= {
2=cisco
!--- Password(2) is "cisco" } reply_attributes= { 6=2 !-
-- Service-Type(6) is Framed (2) 7=1 !--- Framed-
Protocol(7) is PPP (1) } } } # ./ViewProfile -p 9900 -u
isdn_user
User Profile Information
user = isdn_user{
profile_id = 24
profile_cycle = 4
radius=Cisco {
check_items= {
2=cisco
! --- Password(2) is "cisco" } reply_attributes= { 6=2 !
--- Service-Type(6) is Framed (2) 7=1 ! --- Framed-
Protocol(7) is PPP (1) } } }
```

**Observação:** neste cenário simples, as configurações dos usuários assíncronos e ISDN são idênticas.

## CSNT RADIUS

Para configurar o CiscoSecure NT (CSNT) RADIUS:

1. Crie novos usuários chamados isdn\_user e async\_client.
2. Configure a senha apropriada na seção User Setup (Configuração do usuário)
3. Na seção Atributos RADIUS da IETF (Internet Engineering Task Force), selecione os seguintes itens no menu suspenso: **Tipo de serviço (atributo 6) = Framed** e **Framed-Protocol (atributo 7) = PPP****Observação:** você deve clicar na caixa de seleção localizada ao lado dos atributos Service-Type e Framed-Protocol.**Observação:** neste cenário simples, as configurações dos usuários assíncronos e ISDN são idênticas.

```
maui-nas-01

maui-nas-01#show running-config
Building configuration...

Current configuration:
!
version 12.0
service timestamps debug datetime msec
service timestamps log datetime msec
service password-encryption
!
hostname maui-nas-01
!
aaa new-model
!--- Initiates the AAA access control system. !--- This
```

```
command immediately locks down login and PPP
authentication. aaa authentication login default group
radius local !--- Exec login (for the list default) is
authenticated using methods !--- radius then local. The
router uses RADIUS for authentication at the !---
login(exec) prompt. If RADIUS returns an error, the user
is authenticated !--- using the local database. aaa
authentication login NO_AUTHEN none !--- Exec login (for
the list NO_AUTHEN) has authentication method none !---
(no authentication). Interfaces to which this list is
applied will not have !--- authentication enabled. Refer
to the console port (line con 0) configuration. aaa
authentication ppp default if-needed group radius local
!--- PPP authentication (for the list default) uses
methods radius then local. !--- The if-needed keyword
automatically permits ppp for users that have !---
successfully authenticated using exec mode. If the EXEC
facility has !--- authenticated the user, RADIUS
authentication for PPP is not performed. !---This is
necessary for clients that use terminal window after
dial. aaa authorization network default group radius
local !--- Authorization of network services (PPP
services) for the list default !--- uses methods radius
then local. This is necessary if you use RADIUS !---
for the client IP address, Access List assignment and so
on. enable secret 5 <deleted> ! username admin password
7 <deleted> !--- This username allows for access to the
router in situations where !--- connectivity to the
RADIUS server is lost. This is because the AAA !---
configuration for exec login has the alternate method
local. spe 2/0 2/7 firmware location
system:/ucode/mica_port_firmware ! resource-pool disable
! ip subnet-zero no ip finger ! isdn switch-type
primary-ni !--- Switch type is Primary NI-2. isdn voice-
call-failure 0 mta receive maximum-recipients 0 ! !
controller T1 0 !--- T1 0 controller configuration.
framing esf clock source line primary linecode b8zs pri-
group timeslots 1-24 ! controller T1 1 !--- T1 1 is
unused. clock source line secondary 1 ! controller T1 2
!--- T1 1 is unused. ! controller T1 3 !--- T1 1 is
unused. ! interface Ethernet0 ip address 172.22.53.141
255.255.255.0 no ip directed-broadcast ! interface
Serial0:23 !--- D-channel configuration for T1 0. no ip
address no ip directed-broadcast encapsulation ppp
dialer pool-member 23 !--- Assign Serial0:23 as member
of dialer pool 23. !--- Dialer pool 23 is specified in
interface Dialer 1. !--- Interface Dialer 1 will
terminate the ISDN calls. isdn switch-type primary-ni
isdn incoming-voice modem !--- Switch incoming analog
calls to the internal digital modems. no cdp enable !
interface FastEthernet0 no ip address no ip directed-
broadcast shutdown duplex auto speed auto ! interface
Group-Async0 !--- Async Group Interface for the modems.
ip unnumbered Ethernet0 !--- Unnumbered to the ethernet
interface. no ip directed-broadcast encapsulation ppp
async mode interactive !--- Configures interactive mode
on the asynchronous interfaces. !--- This allows users
to dial in and get to a shell or PPP session on !---
that line. If you want incoming users to only connect
using PPP configure !--- async mode dedicated instead.

peer default ip address pool ASYNC
!--- Use the ip pool named "ASYNC" to assign ip address
for !--- incoming connections. ppp authentication chap
```

```

group-range 1 48 !--- Lines(modems) 1 through 48 are in
this group async interface. ! interface Dialer1 !---
Dialer1 will terminate ISDN calls. ip unnumbered
Ethernet0 no ip directed-broadcast encapsulation ppp
dialer pool 23 !--- Dialer 1 uses dialer pool 23.
Interface Serial0:23 is !--- a member of this pool. peer
default ip address pool ISDN !--- Use the ip pool named
"ISDN" to assign ip address for !--- incoming
connections. no cdp enable ppp authentication chap ! ip
local pool ISDN 172.22.53.142 172.22.53.145 !--- IP
address pool named "ISDN". !--- This pool will be
assigned to connections on interface Dialer 1. ip local
pool ASYNC 172.22.53.146 172.22.53.149 !--- IP address
pool named "ASYNC". !--- This pool will be assigned to
incoming connections on Group-Async 0. !--- Note: This
address pool only has 4 addresses and is not sufficient
to !--- support all 48 modem lines. Configure your IP
pool with the address range !--- to support all
connections.

ip classless
no ip http server
!
no cdp run
!
radius-server host 172.22.53.201 auth-port 1645 acct-
port 1646 key cisco
!--- Radius-server host IP address and encryption key.
!--- The encryption key must match the onbe configured
on the RADIUS server. ! line con 0 exec-timeout 0 0
login authentication NO_AUTHEN !--- Specifies that the
AAA list name assigned to the console is !--- NO_AUTHEN.
From the AAA configuration above, the list NO_AUTHEN !---
does not use authentication. transport input none line
1 48 autoselect during-login !--- Displays the
username:password prompt after modems connect. !---
Without this the user must press enter to receive a
prompt. autoselect ppp !--- When the NAS detects
incoming PPP packets, the PPP session !--- will be
launched. modem InOut transport preferred none transport
input all transport output none line aux 0 line vty 0 4
! end

```

## Verificar

Esta seção fornece informações que você pode usar para verificar sua configuração.

## Exemplo de saída de show

```
maui-nas-01#show caller user async_client detail
```

```

User: async_client, line tty 5, service Async
  Active time 00:01:04, Idle time 00:00:22
Timeouts:          Absolute  Idle      Idle
                   Session   Exec
Limits:            -         -         00:10:00
Disconnect in:    -         -         -
TTY: Line 5, running PPP on As5
Location: PPP: 172.22.53.148

```

```
!--- The IP address assigned from the the IP pool. DS0: (slot/unit/channel)=0/0/7 Line: Baud
rate (TX/RX) is 115200/115200, no parity, 1 stopbits, 8 databits Status: Ready, Active, No Exit
Banner, Async Interface Active HW PPP Support Active Capabilities: Hardware Flowcontrol In,
Hardware Flowcontrol Out Modem Callout, Modem RI is CD, Line usable as async interface,
Integrated Modem Modem State: Ready User: async_client, line As5, service PPP Active time
00:00:54, Idle time 00:00:23 Timeouts: Absolute Idle Limits: - - Disconnect in: - - PPP: LCP
Open, CHAP (<- AAA), IPCP
```

```
!--- CHAP authentication was performed by AAA. LCP: -> peer, ACCM, AuthProto, MagicNumber,
PCompression, ACCompression <- peer, ACCM, MagicNumber, PCompression, ACCompression NCP: Open
IPCP IPCP: <- peer, Address -> peer, Address IP: Local 172.22.53.141, remote 172.22.53.148
Counts: 40 packets input, 2769 bytes, 0 no buffer 1 input errors, 1 CRC, 0 frame, 0 overrun 24
packets output, 941 bytes, 0 underruns 0 output errors, 0 collisions, 0 interface resets maui-
nas-01#show caller user isdn_user detail
```

```
User: isdn_user, line Se0:8, service PPP
Active time 00:01:22, Idle time 00:01:24
Timeouts: Absolute Idle
Limits: - 00:02:00
Disconnect in: - 00:00:35
PPP: LCP Open, CHAP (<- AAA), IPCP
```

```
!--- CHAP authentication was performed by AAA. LCP: -> peer, AuthProto, MagicNumber <- peer,
MagicNumber NCP: Open IPCP IPCP: <- peer, Address -> peer, Address Dialer: Connected to ,
inbound Idle timer 120 secs, idle 84 secs Type is ISDN, group Dialer1
```

```
! -- The ISDN Call uses int Dialer1. IP: Local 172.22.53.141, remote 172.22.53.142
! -- The IP address was obtained from the local pool. Counts: 31 packets input, 872 bytes, 0 no
buffer 0 input errors, 0 CRC, 0 frame, 0 overrun 34 packets output, 1018 bytes, 0 underruns 0
output errors, 0 collisions, 5 interface resets
```

## Troubleshoot

Esta seção fornece informações que podem ser usadas para o troubleshooting da sua configuração.

### Comandos para Troubleshooting

A [Output Interpreter Tool \(somente clientes registrados\) oferece suporte a determinados comandos show, o que permite exibir uma análise da saída do comando show.](#)

**Observação:** antes de emitir comandos **debug**, consulte [Informações importantes sobre comandos debug](#).

- **debug isdn q931** Isso mostra a configuração da chamada e desconexão da conexão de rede ISDN (camada 3) entre o roteador e o Switch ISDN.
- **debug modem** - Mostra a atividade da linha do modem em um servidor de acesso.
- **debug ppp negotiation** - Para exibir informações sobre tráfego e trocas de PPP ao negociar o Protocolo de Controle de Enlaces (LCP), autenticação e Protocolo de Controle de Rede (NCP). Uma negociação de PPP bem-sucedida abre primeiramente o estado do LCP e, em seguida, autentica e, finalmente, negocia o NCP.
- **debug ppp authentication** - Para exibir as mensagens do protocolo de autenticação PPP, incluindo trocas de pacote do Protocolo de autenticação de handshake de desafio (CHAP) e trocas do Protocolo de autenticação de senha (PAP).
- **debug aaa authentication** - Para exibir informações sobre a autenticação AAA/RADIUS.
- **debug aaa authorization** - Para exibir informações sobre a autorização AAA/RADIUS.
- **debug radius** - Para exibir informações detalhadas de depuração associadas ao RADIUS. Use a [ferramenta Output Interpreter Tool](#) (somente clientes [registrados](#)) no site do Suporte

Técnico da Cisco para decodificar as mensagens de debug radius. Por exemplo, consulte a saída de depuração mostrada abaixo. Use as informações do raio de depuração para determinar quais atributos são negociados. **Note:** A partir de 12.2(11)T, a saída de debug radius já está decodificada e, portanto, NÃO exige o uso do Output Interpreter para decodificar a saída. Consulte o documento [RADIUS Debug Enhancements](#) para obter mais informações

- **show caller user** - Para mostrar parâmetros para o usuário específico, como a linha TTY usada, interface assíncrona (sub-bastidor, slot ou porta), número de canal DS0, número de modem, endereço IP atribuído, parâmetros de pacote PPP e PPP, etc. Se sua versão do Cisco IOS Software não suporta este comando, utilize o comando show user.

### Exemplo de saída de depuração

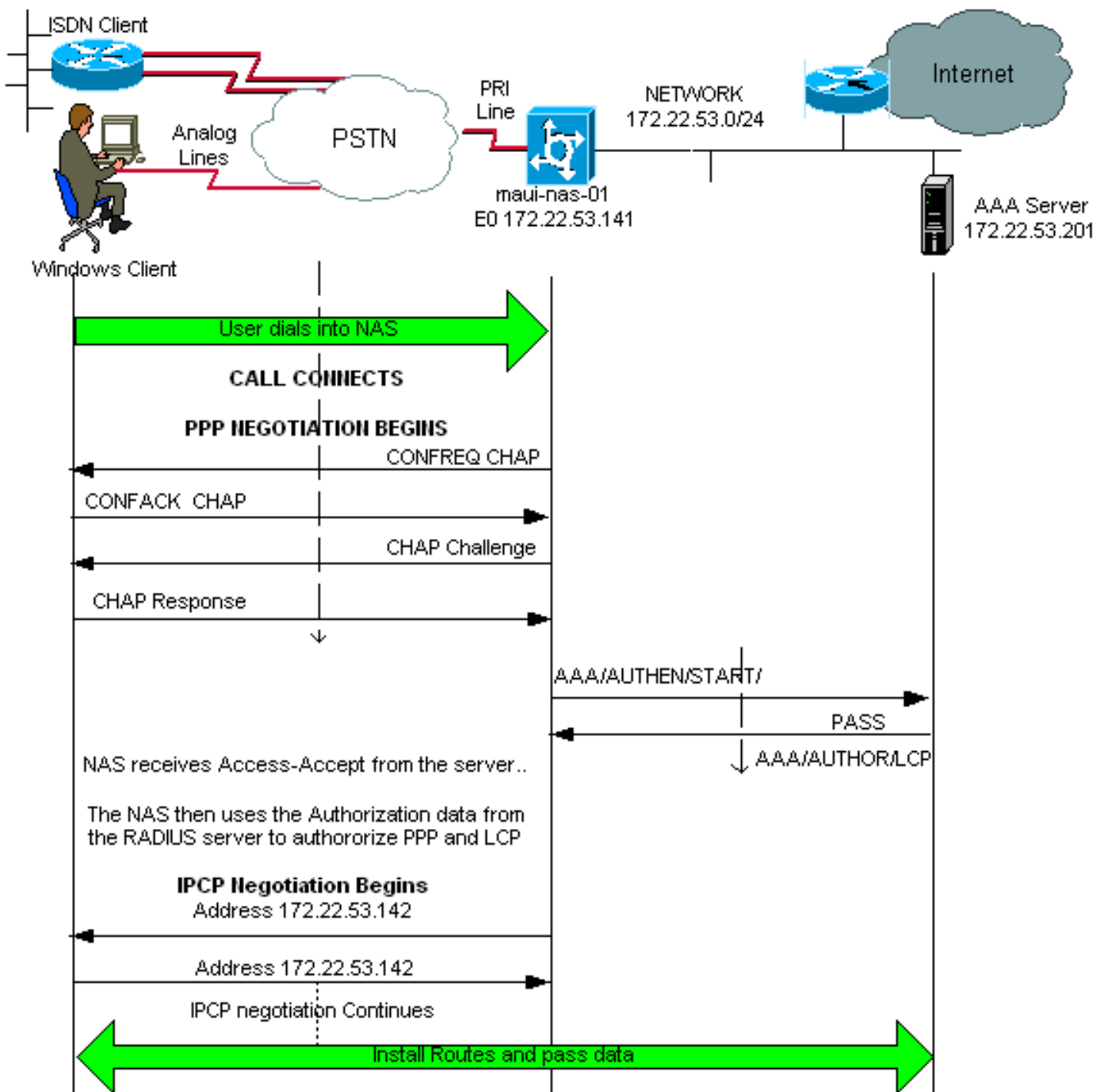

Se você tiver a saída de um comando **debug radius** de seu dispositivo Cisco, poderá usar para exibir possíveis problemas e correções. Para usar , você deve ser um cliente [registrado](#), estar

conectado e ter JavaScript habilitado.

**Observação:** a partir de 12.2(11)T a saída de debug radius já está decodificada e, portanto, NÃO exige o uso do Output Interpreter para decodificar a saída. Consulte o documento [RADIUS Debug Enhancements](#) para obter mais informações

```
maui-nas-01#debug isdn q931
ISDN Q931 packets debugging is on
maui-nas-01#debug ppp negotiation
PPP protocol negotiation debugging is on
maui-nas-01#debug ppp authentication
PPP authentication debugging is on
maui-nas-01#debug modem
Modem control/process activation debugging is on
maui-nas-01#debug aaa authentication
AAA Authentication debugging is on
maui-nas-01#debug aaa authorization
AAA Authorization debugging is on
maui-nas-01#debug radius
RADIUS protocol debugging is on

maui-nas-01#
*Apr  5 11:05:07.031: ISDN Se0:23: RX <-  SETUP pd = 8  callref = 0x20FC
!--- Setup message for incoming call. *Apr  5 11:05:07.031: Bearer Capability i = 0x8890218F *Apr
 5 11:05:07.031: Channel ID i = 0xA18387 *Apr  5 11:05:07.031: Called Party Number i = 0xA1,
'81560' *Apr  5 11:05:07.035: %DIALER-6-BIND: Interface Serial0:6 bound to profile Dialer1 *Apr  5
11:05:07.035: ISDN Se0:23: TX -> CALL_PROC pd = 8  callref = 0xA0FC *Apr  5 11:05:07.035: Channel
ID i = 0xA98387 *Apr  5 11:05:07.043: %LINK-3-UPDOWN: Interface Serial0:6, changed state to up
*Apr  5 11:05:07.043: Se0:6 PPP: Treating connection as a callin *Apr  5 11:05:07.043: Se0:6 PPP:
Phase is ESTABLISHING, Passive Open *Apr  5 11:05:07.043: Se0:6 LCP: State is Listen *Apr  5
11:05:07.047: ISDN Se0:23: TX -> CONNECT pd = 8  callref = 0xA0FC *Apr  5 11:05:07.047: Channel ID
i = 0xA98387 *Apr  5 11:05:07.079: ISDN Se0:23: RX <-  CONNECT_ACK pd = 8  callref = 0x20FC *Apr  5
11:05:07.079: ISDN Se0:23: CALL_PROGRESS: CALL_CONNECTED call id 0x2D, bchan -1, dsl 0 *Apr  5
11:05:07.499: Se0:6 LCP: I CONFREQ [Listen] id 28 len 10 *Apr  5 11:05:07.499: Se0:6 LCP:
MagicNumber 0x5078A51F (0x05065078A51F) *Apr  5 11:05:07.499: Se0:6 AAA/AUTHOR/FSM: (0): LCP
succeeds trivially *Apr  5 11:05:07.499: Se0:6 LCP: O CONFREQ [Listen] id 2 len 15 *Apr  5
11:05:07.499: Se0:6 LCP: AuthProto CHAP (0x0305C22305) *Apr  5 11:05:07.499: Se0:6 LCP:
MagicNumber 0xE05213AA (0x0506E05213AA) *Apr  5 11:05:07.499: Se0:6 LCP: O CONFACK [Listen] id 28
len 10 *Apr  5 11:05:07.499: Se0:6 LCP: MagicNumber 0x5078A51F (0x05065078A51F) *Apr  5
11:05:07.555: Se0:6 LCP: I CONFACK [ACKsent] id 2 len 15 *Apr  5 11:05:07.555: Se0:6 LCP:
AuthProto CHAP (0x0305C22305) *Apr  5 11:05:07.555: Se0:6 LCP: MagicNumber 0xE05213AA
(0x0506E05213AA) *Apr  5 11:05:07.555: Se0:6 LCP: State is Open *Apr  5 11:05:07.555: Se0:6 PPP:
Phase is AUTHENTICATING, by this end *Apr  5 11:05:07.555: Se0:6 CHAP: O CHALLENGE id 2 len 32
from "maui-nas-01" *Apr  5 11:05:07.631: Se0:6 CHAP: I RESPONSE id 2 len 30 from "isdn_user"
!--- Incoming CHAP response from "isdn_user". *Apr  5 11:05:07.631: AAA: parse name=Serial0:6 idb
type=12 tty=-1 *Apr  5 11:05:07.631: AAA: name=Serial0:6 flags=0x51 type=1 shelf=0 slot=0
adapter=0 port=0 channel=6 *Apr  5 11:05:07.631: AAA: parse name= idb type=-1 tty=-1 *Apr  5
11:05:07.631: AAA/MEMORY: create_user (0x619CEE28) user='isdn_user' ruser='' port='Serial0:6'
rem_addr='isdn/81560' authen_type=CHAP service=PPP priv=1 *Apr  5 11:05:07.631: AAA/AUTHEN/START
(2973699846): port='Serial0:6' list='' action=LOGIN service=PPP *Apr  5 11:05:07.631:
AAA/AUTHEN/START (2973699846): using "default" list *Apr  5 11:05:07.631: AAA/AUTHEN
(2973699846): status = UNKNOWN *Apr  5 11:05:07.631: AAA/AUTHEN/START (2973699846): Method=radius
(radius) !--- AAA authentication method is RADIUS. *Apr  5 11:05:07.631: RADIUS: ustruct
sharecount=1 *Apr  5 11:05:07.631: RADIUS: Initial Transmit Serial0:6 id 13 172.22.53.201:1645,
Access-Request, len 87
!--- Access-Request from the NAS to the AAA server. !--- Note the IP address in the Access-
Request matches the IP address !--- configured using the command: !--- radius-server host
172.22.53.201 key cisco *Apr  5 11:05:07.631:          Attribute 4 6 AC16358D
*Apr  5 11:05:07.631:          Attribute 5 6 00004E26
*Apr  5 11:05:07.631:          Attribute 61 6 00000002
*Apr  5 11:05:07.631:          Attribute 1 11 6973646E
```



```

*Apr 5 11:05:07.631:      Attribute 30 7 38313536
*Apr 5 11:05:07.631:      Attribute 3 19 0297959E
*Apr 5 11:05:07.631:      Attribute 6 6 00000002
*Apr 5 11:05:07.631:      Attribute 7 6 00000001
*Apr 5 11:05:07.635: RADIUS: Received from id 13 172.22.53.201:1645,
Access-Accept, len 32
*Apr 5 11:05:07.635:      Attribute 6 6 00000002
*Apr 5 11:05:07.635:      Attribute 7 6 00000001

```

Os pares de valores de atributo (AVPs) do comando **debug radius** precisam ser decodificados para melhor entender a transação entre o NAS e o servidor RADIUS.

**Observação:** a partir de 12.2(11)T a saída de debug radius já está decodificada e, portanto, NÃO exige o uso do Output Interpreter para decodificar a saída. Consulte o documento [RADIUS Debug Enhancements](#) para obter mais informações.

A ferramenta Output Interpreter permite que você receba uma análise da saída **debug radius**.

A seguinte saída em *itálico* é o resultado obtido da ferramenta Output Interpreter:

```

Access-Request 172.22.53.201:1645 id 13
Attribute Type 4:  NAS-IP-Address is 172.22.53.141
Attribute Type 5:  NAS-Port is 20006
Attribute Type 61: NAS-Port-Type is ISDN-Synchronous
Attribute Type 1:  User-Name is isdn
Attribute Type 30: Called-Station-ID(DNIS) is 8156
Attribute Type 3:  CHAP-Password is (encoded)
Attribute Type 6:  Service-Type is Framed
Attribute Type 7:  Framed-Protocol is PPP
Access-Accept 172.22.53.201:1645 id 13
Attribute Type 6:  Service-Type is Framed
Attribute Type 7:  Framed-Protocol is PPP

```

Na saída de depuração decodificada pela ferramenta, verifique se **Attribute Type 6: O tipo de serviço é enquadrado e o tipo de atributo 7: Framed-Protocol é PPP**. Se você observar que os Atributos 6 ou 7 não são como mostrado, corrija o perfil do usuário no servidor RADIUS (consulte a seção [Configuração](#)). Observe também que **debug radius** mostra um **Access-Accept**, que indica que o servidor RADIUS autenticou o usuário com êxito. Se a saída mostrar um **Access-Reject**, o usuário não foi autenticado e você deve verificar a configuração de nome de usuário e senha no servidor RADIUS. Outro atributo a ser verificado é o **atributo tipo 4: NAS-IP-Address**. Verifique se o valor exibido pela Output Interpreter Tool corresponde ao endereço IP NAS configurado no servidor RADIUS.

**Observação:** devido às restrições do Cisco IOS e diferenças na saída de depuração com versões diferentes, alguns atributos podem ser truncados (por exemplo, **Nome de usuário, ID da estação chamada(DNIS)**).

```

*Apr 5 11:05:07.635: AAA/AUTHEN (2973699846): status = PASS
!--- Authentication is successful *Apr 5 11:05:07.635: Se0:6 AAA/AUTHOR/LCP: Authorize LCP *Apr
5 11:05:07.635: Se0:6 AAA/AUTHOR/LCP (2783657211): Port='Serial0:6' list='' service=NET *Apr 5
11:05:07.635: AAA/AUTHOR/LCP: Se0:6 (2783657211) user='isdn_user' *Apr 5 11:05:07.635: Se0:6
AAA/AUTHOR/LCP (2783657211): send AV service=ppp *Apr 5 11:05:07.635: Se0:6 AAA/AUTHOR/LCP
(2783657211): send AV protocol=lcp *Apr 5 11:05:07.635: Se0:6 AAA/AUTHOR/LCP (2783657211): found
list "default" *Apr 5 11:05:07.635: Se0:6 AAA/AUTHOR/LCP (2783657211): Method=radius (radius)
*Apr 5 11:05:07.635: Se0:6 AAA/AUTHOR (2783657211): Post authorization status = PASS_REPL *Apr 5
11:05:07.639: Se0:6 AAA/AUTHOR/LCP: Processing AV service=ppp *Apr 5 11:05:07.639: Se0:6 CHAP: O
SUCCESS id 2 len 4 *Apr 5 11:05:07.639: Se0:6 PPP: Phase is UP *Apr 5 11:05:07.639: Se0:6

```

```
AAA/AUTHOR/FSM: (0): Can we start IPCP? *Apr 5 11:05:07.639: Se0:6 AAA/AUTHOR/FSM (3184893369):
Port='Serial0:6' list='' service=NET *Apr 5 11:05:07.639: AAA/AUTHOR/FSM: Se0:6 (3184893369)
user='isdn_user' *Apr 5 11:05:07.639: Se0:6 AAA/AUTHOR/FSM (3184893369): send AV service=ppp
*Apr 5 11:05:07.639: Se0:6 AAA/AUTHOR/FSM (3184893369): send AV protocol=ip *Apr 5 11:05:07.639:
Se0:6 AAA/AUTHOR/FSM (3184893369): found list "default" *Apr 5 11:05:07.639: Se0:6
AAA/AUTHOR/FSM (3184893369): Method=radius (radius) *Apr 5 11:05:07.639: Se0:6 AAA/AUTHOR
(3184893369): Post authorization status = PASS_REPL *Apr 5 11:05:07.639: Se0:6 AAA/AUTHOR/FSM:
We can start IPCP *Apr 5 11:05:07.639: Se0:6 IPCP: O CONFREQ [Not negotiated] id 2 len 10 *Apr 5
11:05:07.639: Se0:6 IPCP: Address 172.22.53.141 (0x0306AC16358D) *Apr 5 11:05:07.675: Se0:6
IPCP: I CONFREQ [REQsent] id 13 len 10 *Apr 5 11:05:07.675: Se0:6 IPCP: Address 0.0.0.0
(0x030600000000) *Apr 5 11:05:07.675: Se0:6 AAA/AUTHOR/IPCP: Start. Her address 0.0.0.0, we want
0.0.0.0 *Apr 5 11:05:07.675: Se0:6 AAA/AUTHOR/IPCP: Processing AV service=ppp *Apr 5
11:05:07.675: Se0:6 AAA/AUTHOR/IPCP: Authorization succeeded *Apr 5 11:05:07.675: Se0:6
AAA/AUTHOR/IPCP: Done. Her address 0.0.0.0, we want 0.0.0.0 *Apr 5 11:05:07.675: Se0:6 IPCP:
```

**Pool returned 172.22.53.142**

```
!--- IP address for the peer obtained from the pool *Apr 5 11:05:07.675: Se0:6 IPCP: O CONFNAK
[REQsent] id 13 len 10 *Apr 5 11:05:07.675: Se0:6 IPCP: Address 172.22.53.142 (0x0306AC16358E)
*Apr 5 11:05:07.699: Se0:6 IPCP: I CONFACK [REQsent] id 2 len 10 *Apr 5 11:05:07.699: Se0:6
IPCP: Address 172.22.53.141 (0x0306AC16358D) *Apr 5 11:05:07.707: Se0:6 IPCP: I CONFREQ
[ACKrcvd] id 14 len 10 *Apr 5 11:05:07.707: Se0:6 IPCP: Address 172.22.53.142 (0x0306AC16358E)
*Apr 5 11:05:07.707: Se0:6 AAA/AUTHOR/IPCP: Start. Her address 172.22.53.142, we want
172.22.53.142 *Apr 5 11:05:07.707: Se0:6 AAA/AUTHOR/IPCP (3828612481): Port='Serial0:6' list=''
service=NET *Apr 5 11:05:07.707: AAA/AUTHOR/IPCP: Se0:6 (3828612481) user='isdn_user' *Apr 5
11:05:07.707: Se0:6 AAA/AUTHOR/IPCP (3828612481): send AV service=ppp *Apr 5 11:05:07.707: Se0:6
AAA/AUTHOR/IPCP (3828612481): send AV protocol=ip *Apr 5 11:05:07.707: Se0:6 AAA/AUTHOR/IPCP
(3828612481): send AV addr*172.22.53.142 *Apr 5 11:05:07.707: Se0:6 AAA/AUTHOR/IPCP
(3828612481): found list "default" *Apr 5 11:05:07.707: Se0:6 AAA/AUTHOR/IPCP (3828612481):
Method=radius (radius) *Apr 5 11:05:07.707: Se0:6 AAA/AUTHOR (3828612481): Post authorization
status = PASS_REPL *Apr 5 11:05:07.707: Se0:6 AAA/AUTHOR/IPCP: Reject 172.22.53.142, using
172.22.53.142 *Apr 5 11:05:07.707: Se0:6 AAA/AUTHOR/IPCP: Processing AV service=ppp *Apr 5
11:05:07.707: Se0:6 AAA/AUTHOR/IPCP: Processing AV addr*172.22.53.142 *Apr 5 11:05:07.707: Se0:6
AAA/AUTHOR/IPCP: Authorization succeeded *Apr 5 11:05:07.707: Se0:6 AAA/AUTHOR/IPCP: Done. Her
address 172.22.53.142, we want 172.22.53.142 *Apr 5 11:05:07.707: Se0:6 IPCP: O CONFACK
[ACKrcvd] id 14 len 10 *Apr 5 11:05:07.707: Se0:6 IPCP: Address 172.22.53.142 (0x0306AC16358E)
*Apr 5 11:05:07.707: Se0:6 IPCP: State is Open *Apr 5 11:05:07.711: Dial IPCP: Install route to
172.22.53.142
```

```
!--- IPCP state is open. A route to the remote peer is installed *Apr 5 11:05:08.639:
%LINEPROTO-5-UPDOWN: Line protocol on Interface Serial0:6, changed state to up *Apr 5
11:05:13.043: %ISDN-6-CONNECT: Interface Serial0:6 is now connected to isdn_user maui-nas-01#
```

Isso conclui a negociação para o cliente ISDN. A saída mostrada abaixo mostra a negociação de uma chamada assíncrona (por exemplo, um cliente Windows)

maui-nas-01#

```
*Apr 5 11:05:53.527: ISDN Se0:23: RX <- SETUP pd = 8 callref = 0x21C5
!--- Incoming Setup message for Async Call. *Apr 5 11:05:53.527: Bearer Capability i = 0x9090A2
*Apr 5 11:05:53.527: Channel ID i = 0xA18388 *Apr 5 11:05:53.527: Progress Ind i = 0x8183 -
Origination address is non-ISDN *Apr 5 11:05:53.527: Called Party Number i = 0xA1, '81560' *Apr
5 11:05:53.531: ISDN Se0:23: TX -> CALL_PROC pd = 8 callref = 0xA1C5 *Apr 5 11:05:53.531:
Channel ID i = 0xA98388 *Apr 5 11:05:53.531: ISDN Se0:23: TX -> ALERTING pd = 8 callref = 0xA1C5
*Apr 5 11:05:53.667: ISDN Se0:23: TX -> CONNECT pd = 8 callref = 0xA1C5 *Apr 5 11:05:53.683:
ISDN Se0:23: RX <- CONNECT_ACK pd = 8 callref = 0x21C5 *Apr 5 11:05:53.687: ISDN Se0:23:
CALL_PROGRESS: CALL_CONNECTED call id 0x2E, bchan -1, dsl 0 *Apr 5 11:06:10.815: TTY5: DSR came
up *Apr 5 11:06:10.815: tty5: Modem: IDLE->(unknown) *Apr 5 11:06:10.815: TTY5: EXEC creation
*Apr 5 11:06:10.815: AAA: parse name=tty5 idb type=10 tty=5 *Apr 5 11:06:10.815: AAA: name=tty5
flags=0x11 type=4 shelf=0 slot=0 adapter=0 port=5 channel=0 *Apr 5 11:06:10.815: AAA: parse
name=Serial0:7 idb type=12 tty=-1 *Apr 5 11:06:10.815: AAA: name=Serial0:7 flags=0x51 type=1
shelf=0 slot=0 adapter=0 port=0 channel=7 *Apr 5 11:06:10.815: AAA/MEMORY: create_user
(0x614D4DBC) user='' ruser='' port='tty5' rem_addr='async/81560' authen_type=ASCII service=LOGIN
priv=1 *Apr 5 11:06:10.815: AAA/AUTHEN/START (2673527044): port='tty5' list='' action=LOGIN
service=LOGIN *Apr 5 11:06:10.815: AAA/AUTHEN/START (2673527044): using "default" list *Apr 5
11:06:10.815: AAA/AUTHEN/START (2673527044): Method=radius (radius) *Apr 5 11:06:10.815:
AAA/AUTHEN (2673527044): status = GETUSER *Apr 5 11:06:10.815: TTY5: set timer type 10, 30
```

seconds \*Apr 5 11:06:13.475: TTY5: Autoselect(2) sample 7E \*Apr 5 11:06:13.475: TTY5:  
Autoselect(2) sample 7EFF \*Apr 5 11:06:13.475: TTY5: Autoselect(2) sample 7EFF7D \*Apr 5  
11:06:13.475: TTY5: Autoselect(2) sample 7EFF7D23 \*Apr 5 11:06:13.475: **TTY5 Autoselect cmd: ppp  
negotiate**

*!--- the router recongnizes the ppp packets and launches ppp.* \*Apr 5 11:06:13.475:  
AAA/AUTHEN/ABORT: (2673527044) because Autoselected. \*Apr 5 11:06:13.475: AAA/MEMORY: free\_user  
(0x614D4DBC) user='' ruser='' port='tty5' rem\_addr='async/81560' authen\_type=ASCII service=LOGIN  
priv=1 \*Apr 5 11:06:13.479: TTY5: EXEC creation \*Apr 5 11:06:13.479: TTY5: create timer type 1,  
600 seconds \*Apr 5 11:06:13.607: TTY5: destroy timer type 1 (OK) \*Apr 5 11:06:13.607: TTY5:  
destroy timer type 0 \*Apr 5 11:06:15.607: %LINK-3-UPDOWN: Interface Async5, changed state to up  
\*Apr 5 11:06:15.607: As5 PPP: Treating connection as a dedicated line \*Apr 5 11:06:15.607: As5  
**PPP: Phase is ESTABLISHING, Active Open**

*!--- PPP negotiation begins.* \*Apr 5 11:06:15.607: As5 AAA/AUTHOR/FSM: (0): LCP succeeds  
trivially \*Apr 5 11:06:15.607: As5 LCP: O CONFREQ [Closed] id 1 len 25 \*Apr 5 11:06:15.607: As5  
LCP: ACCM 0x000A0000 (0x0206000A0000) \*Apr 5 11:06:15.607: As5 LCP: AuthProto CHAP  
(0x0305C22305) \*Apr 5 11:06:15.607: As5 LCP: MagicNumber 0xE0531DB8 (0x0506E0531DB8) \*Apr 5  
11:06:15.607: As5 LCP: PFC (0x0702) \*Apr 5 11:06:15.607: As5 LCP: ACFC (0x0802) \*Apr 5  
11:06:16.487: As5 LCP: I CONFREQ [REQsent] id 3 len 23 \*Apr 5 11:06:16.487: As5 LCP: ACCM  
0x000A0000 (0x0206000A0000) \*Apr 5 11:06:16.487: As5 LCP: MagicNumber 0x65FFA5C7  
(0x050665FFA5C7) \*Apr 5 11:06:16.487: As5 LCP: PFC (0x0702) \*Apr 5 11:06:16.487: As5 LCP: ACFC  
(0x0802) \*Apr 5 11:06:16.487: As5 LCP: Callback 6 (0x0D0306) \*Apr 5 11:06:16.487: Unthrottle 5  
\*Apr 5 11:06:16.487: As5 LCP: O CONFREQ [REQsent] id 3 len 7 \*Apr 5 11:06:16.487: As5 LCP:  
Callback 6 (0x0D0306) \*Apr 5 11:06:17.607: As5 LCP: TIMEOUT: State REQsent \*Apr 5 11:06:17.607:  
As5 LCP: O CONFREQ [REQsent] id 2 len 25 \*Apr 5 11:06:17.607: As5 LCP: ACCM 0x000A0000  
(0x0206000A0000) \*Apr 5 11:06:17.607: As5 LCP: AuthProto CHAP (0x0305C22305) \*Apr 5  
11:06:17.607: As5 LCP: MagicNumber 0xE0531DB8 (0x0506E0531DB8) \*Apr 5 11:06:17.607: As5 LCP: PFC  
(0x0702) \*Apr 5 11:06:17.607: As5 LCP: ACFC (0x0802) \*Apr 5 11:06:17.735: As5 LCP: I CONFACK  
[REQsent] id 2 len 25 \*Apr 5 11:06:17.735: As5 LCP: ACCM 0x000A0000 (0x0206000A0000) \*Apr 5  
11:06:17.735: As5 LCP: AuthProto CHAP (0x0305C22305) \*Apr 5 11:06:17.735: As5 LCP: MagicNumber  
0xE0531DB8 (0x0506E0531DB8) \*Apr 5 11:06:17.735: As5 LCP: PFC (0x0702) \*Apr 5 11:06:17.735: As5  
LCP: ACFC (0x0802) \*Apr 5 11:06:19.479: As5 LCP: I CONFREQ [ACKrcvd] id 4 len 23 \*Apr 5  
11:06:19.479: As5 LCP: ACCM 0x000A0000 (0x0206000A0000) \*Apr 5 11:06:19.479: As5 LCP:  
MagicNumber 0x65FFA5C7 (0x050665FFA5C7) \*Apr 5 11:06:19.479: As5 LCP: PFC (0x0702) \*Apr 5  
11:06:19.479: As5 LCP: ACFC (0x0802) \*Apr 5 11:06:19.479: As5 LCP: Callback 6 (0x0D0306) \*Apr 5  
11:06:19.479: As5 LCP: O CONFREQ [ACKrcvd] id 4 len 7 \*Apr 5 11:06:19.479: As5 LCP: Callback 6  
(0x0D0306) \*Apr 5 11:06:19.607: As5 LCP: TIMEOUT: State ACKrcvd \*Apr 5 11:06:19.607: As5 LCP: O  
CONFREQ [ACKrcvd] id 3 len 25 \*Apr 5 11:06:19.607: As5 LCP: ACCM 0x000A0000 (0x0206000A0000)  
\*Apr 5 11:06:19.607: As5 LCP: AuthProto CHAP (0x0305C22305) \*Apr 5 11:06:19.607: As5 LCP:  
MagicNumber 0xE0531DB8 (0x0506E0531DB8) \*Apr 5 11:06:19.607: As5 LCP: PFC (0x0702) \*Apr 5  
11:06:19.607: As5 LCP: ACFC (0x0802) \*Apr 5 11:06:19.607: As5 LCP: I CONFREQ [REQsent] id 5 len  
20 \*Apr 5 11:06:19.607: As5 LCP: ACCM 0x000A0000 (0x0206000A0000) \*Apr 5 11:06:19.607: As5 LCP:  
MagicNumber 0x65FFA5C7 (0x050665FFA5C7) \*Apr 5 11:06:19.607: As5 LCP: PFC (0x0702) \*Apr 5  
11:06:19.607: As5 LCP: ACFC (0x0802) \*Apr 5 11:06:19.607: As5 LCP: O CONFREQ [REQsent] id 5 len  
20 \*Apr 5 11:06:19.607: As5 LCP: ACCM 0x000A0000 (0x0206000A0000) \*Apr 5 11:06:19.607: As5 LCP:  
MagicNumber 0x65FFA5C7 (0x050665FFA5C7) \*Apr 5 11:06:19.607: As5 LCP: PFC (0x0702) \*Apr 5  
11:06:19.607: As5 LCP: ACFC (0x0802) \*Apr 5 11:06:19.719: As5 LCP: I CONFACK [ACKsent] id 3 len  
25 \*Apr 5 11:06:19.719: As5 LCP: ACCM 0x000A0000 (0x0206000A0000) \*Apr 5 11:06:19.719: As5 LCP:  
AuthProto CHAP (0x0305C22305) \*Apr 5 11:06:19.719: As5 LCP: MagicNumber 0xE0531DB8  
(0x0506E0531DB8) \*Apr 5 11:06:19.719: As5 LCP: PFC (0x0702) \*Apr 5 11:06:19.719: As5 LCP: ACFC  
(0x0802) \*Apr 5 11:06:19.719: As5 LCP: State is Open \*Apr 5 11:06:19.719: As5 PPP: Phase is  
AUTHENTICATING, by this end \*Apr 5 11:06:19.719: As5 CHAP: O CHALLENGE id 1 len 32 from "maui-  
nas-01" \*Apr 5 11:06:19.863: As5 **CHAP: I RESPONSE id 1 len 33 from "async\_client"**

*!--- Incoming CHAP response from "async\_client".* \*Apr 5 11:06:19.863: AAA: parse name=Async5 idb  
type=10 tty=5 \*Apr 5 11:06:19.863: AAA: name=Async5 flags=0x11 type=4 shelf=0 slot=0 adapter=0  
port=5 channel=0 \*Apr 5 11:06:19.863: AAA: parse name=Serial0:7 idb type=12 tty=-1 \*Apr 5  
11:06:19.863: AAA: name=Serial0:7 flags=0x51 type=1 shelf=0 slot=0 adapter=0 port=0 channel=7  
\*Apr 5 11:06:19.863: AAA/MEMORY: create\_user (0x6195AE40) user='async\_client' ruser=''  
port='Async5' rem\_addr='async/81560' authen\_type=CHAP service=PPP priv=1 \*Apr 5 11:06:19.863:  
AAA/AUTHEN/START (2673347869): port='Async5' list='' action=LOGIN service=PPP \*Apr 5  
11:06:19.863: AAA/AUTHEN/START (2673347869): using "default" list \*Apr 5 11:06:19.863:  
AAA/AUTHEN (2673347869): status = UNKNOWN \*Apr 5 11:06:19.863: AAA/AUTHEN/START (2673347869):  
Method=radius (radius) \*Apr 5 11:06:19.863: RADIUS: ustruct sharecount=1 **\*Apr 5 11:06:19.867:  
RADIUS: Initial Transmit Async5 id 14 172.22.53.201:1645,  
Access-Request, len 90**

```

*Apr 5 11:06:19.867:      Attribute 4 6 AC16358D
*Apr 5 11:06:19.867:      Attribute 5 6 00000005
*Apr 5 11:06:19.867:      Attribute 61 6 00000000
*Apr 5 11:06:19.867:      Attribute 1 14 6173796E
*Apr 5 11:06:19.867:      Attribute 30 7 38313536
*Apr 5 11:06:19.867:      Attribute 3 19 01B8292F
*Apr 5 11:06:19.867:      Attribute 6 6 00000002
*Apr 5 11:06:19.867:      Attribute 7 6 00000001
*Apr 5 11:06:19.867: RADIUS: Received from id 14 172.22.53.201:1645,
Access-Accept, len 32
*Apr 5 11:06:19.867:      Attribute 6 6 00000002
*Apr 5 11:06:19.871:      Attribute 7 6 00000001

```

Os AVPs do comando debug radius precisam ser decodificados para entender melhor a transação entre o NAS e o servidor RADIUS.

**Observação:** a partir de 12.2(11)T a saída de debug radius já está decodificada e, portanto, NÃO exige o uso do Output Interpreter para decodificar a saída. Consulte o documento [RADIUS Debug Enhancements](#) para obter mais informações

A ferramenta Output Interpreter permite que você receba uma análise da saída de debug radius.

A seguinte saída em *itálico* é o resultado obtido da ferramenta Output Interpreter:

```

Access-Request 172.22.53.201:1645 id 14
Attribute Type 4:  NAS-IP-Address is 172.22.53.141
Attribute Type 5:  NAS-Port is 5
Attribute Type 61: NAS-Port-Type is Asynchronous
Attribute Type 1:  User-Name is asyn
Attribute Type 30: Called-Station-ID(DNIS) is 8156
Attribute Type 3:  CHAP-Password is (encoded)
Attribute Type 6:  Service-Type is Framed
Attribute Type 7:  Framed-Protocol is PPP
      Access-Accept 172.22.53.201:1645 id 14
Attribute Type 6:  Service-Type is Framed
Attribute Type 7:  Framed-Protocol is PPP

```

Na saída de depuração decodificada pela ferramenta, verifique se **Attribute Type 6: O tipo de serviço é enquadrado e o tipo de atributo 7: Framed-Protocol é PPP**. Se você observar que os Atributos 6 ou 7 não são como mostrado, corrija o perfil do usuário no servidor RADIUS (consulte a seção [Configuração](#)). Observe também que **debug radius** mostra um **Access-Accept**, que indica que o servidor RADIUS autenticou o usuário com êxito. Se a saída mostrar um **Access-Reject**, o usuário não foi autenticado e você deve verificar a configuração de nome de usuário e senha no servidor RADIUS. Outro atributo a ser verificado é o **atributo tipo 4: NAS-IP-Address**. Verifique se o valor exibido pela Output Interpreter Tool corresponde ao endereço IP NAS configurado no servidor RADIUS.

**Observação:** devido às restrições do Cisco IOS e diferenças na saída de depuração com versões diferentes, alguns atributos podem ser truncados (por exemplo, **Nome de usuário, ID da estação chamada(DNIS)**).

```

*Apr 5 11:06:19.871: AAA/AUTHEN (2673347869): status = PASS
*Apr 5 11:06:19.871: As5 AAA/AUTHOR/LCP: Authorize LCP
*Apr 5 11:06:19.871: As5 AAA/AUTHOR/LCP (3232903941): Port='Async5' list=''
service=NET
*Apr 5 11:06:19.871: AAA/AUTHOR/LCP: As5 (3232903941) user='async_client'

```

```
*Apr 5 11:06:19.871: As5 AAA/AUTHOR/LCP (3232903941): send AV service=ppp
*Apr 5 11:06:19.871: As5 AAA/AUTHOR/LCP (3232903941): send AV protocol=lcp
*Apr 5 11:06:19.871: As5 AAA/AUTHOR/LCP (3232903941): found list "default"
*Apr 5 11:06:19.871: As5 AAA/AUTHOR/LCP (3232903941): Method=radius (radius)
*Apr 5 11:06:19.871: As5 AAA/AUTHOR (3232903941): Post authorization status
= PASS_REPL
*Apr 5 11:06:19.871: As5 AAA/AUTHOR/LCP: Processing AV service=ppp
*Apr 5 11:06:19.871: As5 CHAP: O SUCCESS id 1 len 4
*Apr 5 11:06:19.871: As5 PPP: Phase is UP
*Apr 5 11:06:19.871: As5 AAA/AUTHOR/FSM: (0): Can we start IPCP?
*Apr 5 11:06:19.871: As5 AAA/AUTHOR/FSM (1882093345): Port='Async5' list=''
service=NET
*Apr 5 11:06:19.871: AAA/AUTHOR/FSM: As5 (1882093345) user='async_client'
*Apr 5 11:06:19.871: As5 AAA/AUTHOR/FSM (1882093345): send AV service=ppp
*Apr 5 11:06:19.871: As5 AAA/AUTHOR/FSM (1882093345): send AV protocol=ip
*Apr 5 11:06:19.871: As5 AAA/AUTHOR/FSM (1882093345): found list "default"
*Apr 5 11:06:19.871: As5 AAA/AUTHOR/FSM (1882093345): Method=radius (radius)
*Apr 5 11:06:19.871: As5 AAA/AUTHOR (1882093345): Post authorization status
= PASS_REPL
*Apr 5 11:06:19.871: As5 AAA/AUTHOR/FSM: We can start IPCP
*Apr 5 11:06:19.875: As5 IPCP: O CONFREQ [Closed] id 1 len 10
*Apr 5 11:06:19.875: As5 IPCP: Address 172.22.53.141 (0x0306AC16358D)
*Apr 5 11:06:19.991: As5 IPCP: I CONFREQ [REQsent] id 1 len 34
*Apr 5 11:06:19.991: As5 IPCP: Address 0.0.0.0 (0x030600000000)
*Apr 5 11:06:19.991: As5 IPCP: PrimaryDNS 0.0.0.0 (0x810600000000)
*Apr 5 11:06:19.991: As5 IPCP: PrimaryWINS 0.0.0.0 (0x820600000000)
*Apr 5 11:06:19.991: As5 IPCP: SecondaryDNS 0.0.0.0 (0x830600000000)
*Apr 5 11:06:19.991: As5 IPCP: SecondaryWINS 0.0.0.0 (0x840600000000)
*Apr 5 11:06:19.991: As5 AAA/AUTHOR/IPCP: Start. Her address 0.0.0.0,
we want 172.22.53.148
!--- The address for the peer obtained from the pool. *Apr 5 11:06:19.991: As5 AAA/AUTHOR/IPCP:
Processing AV service=ppp *Apr 5 11:06:19.991: As5 AAA/AUTHOR/IPCP: Authorization succeeded *Apr 5
11:06:19.991: As5 AAA/AUTHOR/IPCP: Done. Her address 0.0.0.0, we want 172.22.53.148 *Apr 5
11:06:19.991: As5 IPCP: O CONFREQ [REQsent] id 1 len 22 *Apr 5 11:06:19.991: As5 IPCP:
PrimaryWINS 0.0.0.0 (0x820600000000) *Apr 5 11:06:19.995: As5 IPCP: SecondaryDNS 0.0.0.0
(0x830600000000) *Apr 5 11:06:19.995: As5 IPCP: SecondaryWINS 0.0.0.0 (0x840600000000) *Apr 5
11:06:20.007: As5 IPCP: I CONFACK [REQsent] id 1 len 10 *Apr 5 11:06:20.007: As5 IPCP: Address
172.22.53.141 (0x0306AC16358D) *Apr 5 11:06:20.119: As5 IPCP: I CONFREQ [ACKrcvd] id 2 len 16
*Apr 5 11:06:20.119: As5 IPCP: Address 0.0.0.0 (0x030600000000) *Apr 5 11:06:20.119: As5 IPCP:
PrimaryDNS 0.0.0.0 (0x810600000000) *Apr 5 11:06:20.119: As5 AAA/AUTHOR/IPCP: Start. Her address
0.0.0.0, we want 172.22.53.148 *Apr 5 11:06:20.119: As5 AAA/AUTHOR/IPCP: Processing AV
service=ppp *Apr 5 11:06:20.119: As5 AAA/AUTHOR/IPCP: Authorization succeeded *Apr 5
11:06:20.119: As5 AAA/AUTHOR/IPCP: Done. Her address 0.0.0.0, we want 172.22.53.148 *Apr 5
11:06:20.119: As5 IPCP: O CONFNAK [ACKrcvd] id 2 len 16 *Apr 5 11:06:20.119: As5 IPCP: Address
172.22.53.148 (0x0306AC163594) *Apr 5 11:06:20.119: As5 IPCP: PrimaryDNS 172.22.53.210
(0x8106AC1635D2) *Apr 5 11:06:20.231: As5 IPCP: I CONFREQ [ACKrcvd] id 3 len 16 *Apr 5
11:06:20.231: As5 IPCP: Address 172.22.53.148 (0x0306AC163594) *Apr 5 11:06:20.231: As5 IPCP:
PrimaryDNS 172.22.53.210 (0x8106AC1635D2) *Apr 5 11:06:20.231: As5 AAA/AUTHOR/IPCP: Start. Her
address 172.22.53.148, we want 172.22.53.148 *Apr 5 11:06:20.231: As5 AAA/AUTHOR/IPCP
(3727543204): Port='Async5' list='' service=NET *Apr 5 11:06:20.231: AAA/AUTHOR/IPCP: As5
(3727543204) user='async_client' *Apr 5 11:06:20.231: As5 AAA/AUTHOR/IPCP (3727543204): send AV
service=ppp *Apr 5 11:06:20.231: As5 AAA/AUTHOR/IPCP (3727543204): send AV protocol=ip *Apr 5
11:06:20.231: As5 AAA/AUTHOR/IPCP (3727543204): send AV addr*172.22.53.148 *Apr 5 11:06:20.231:
As5 AAA/AUTHOR/IPCP (3727543204): found list "default" *Apr 5 11:06:20.231: As5 AAA/AUTHOR/IPCP
(3727543204): Method=radius (radius) *Apr 5 11:06:20.235: As5 AAA/AUTHOR (3727543204): Post
authorization status = PASS_REPL *Apr 5 11:06:20.235: As5 AAA/AUTHOR/IPCP: Reject 172.22.53.148,
using 172.22.53.148 *Apr 5 11:06:20.235: As5 AAA/AUTHOR/IPCP: Processing AV service=ppp *Apr 5
11:06:20.235: As5 AAA/AUTHOR/IPCP: Processing AV addr*172.22.53.148 *Apr 5 11:06:20.235: As5
AAA/AUTHOR/IPCP: Authorization succeeded *Apr 5 11:06:20.235: As5 AAA/AUTHOR/IPCP: Done. Her
address 172.22.53.148, we want 172.22.53.148 *Apr 5 11:06:20.235: As5 IPCP: O CONFACK [ACKrcvd]
id 3 len 16 *Apr 5 11:06:20.235: As5 IPCP: Address 172.22.53.148 (0x0306AC163594) *Apr 5
11:06:20.235: As5 IPCP: PrimaryDNS 172.22.53.210 (0x8106AC1635D2) *Apr 5 11:06:20.235: As5 IPCP:
State is Open *Apr 5 11:06:20.235: As5 IPCP: Install route to 172.22.53.148
!--- Route to remote peer is installed. *Apr 5 11:06:20.871: %LINEPROTO-5-UPDOWN: Line protocol
```

on Interface Async5, changed state to up

## **Informações Relacionadas**

- [Suporte Técnico e Documentação - Cisco Systems](#)