

Vérification des fonctions SPAN et ERSPAN sur les commutateurs de la gamme Catalyst 9000

Contenu

[Introduction](#)

[Conditions préalables](#)

[Conditions requises](#)

[Components Used](#)

[Vérification de SPAN](#)

[Diagramme du réseau](#)

[Configuration SPAN](#)

[Vérifier ERSPAN](#)

[Diagramme du réseau](#)

[Configuration ERSPAN](#)

[Périphérique source](#)

[Périphérique de destination ERSPAN](#)

[Débogages et suivis pertinents](#)

[Informations connexes](#)

Introduction

Ce document décrit comment vérifier SPAN et ERSPAN sur les commutateurs de la gamme Catalyst 9000.

Conditions préalables

Conditions requises

Aucune spécification déterminée n'est requise pour ce document.

Components Used

Les informations contenues dans ce document sont basées sur les versions de matériel et de logiciel suivantes :

- Catalyst 9300 (Cisco IOS®-XE 17.3.5)
- Catalyst 9500 (Cisco IOS®-XE 17.3.5)

The information in this document was created from the devices in a specific lab environment. All of the devices used in this document started with a cleared (default) configuration. Si votre réseau est en ligne, assurez-vous de bien comprendre l'incidence possible des commandes.

Produits connexes

Ce document peut également être utilisé avec les versions de matériel et de logiciel suivantes :

- Catalyst 9200
- Catalyst 9300
- Catalyst 9500
- Catalyst 9400
- Catalyst 9600

Vérification de SPAN

Diagramme du réseau

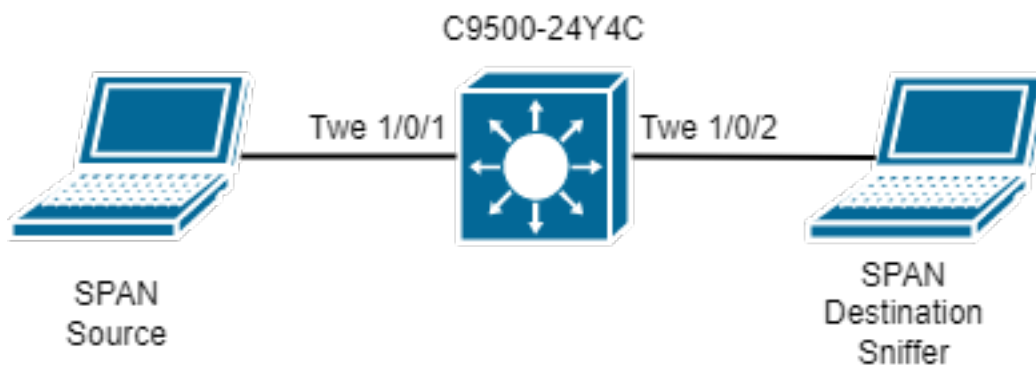

Configuration SPAN

```
monitor session 1 source interface Twel1/0/1
monitor session 1 destination interface Twel1/0/2
```

Vérifiez la configuration du logiciel SPAN. Notez les interfaces SPAN source et de destination et la direction de la capture SPAN.

```
C9500-SPAN#show monitor session all
Session 1
-----
Type                : Local Session
Source Ports        :
  Both               : Twel1/0/1
Destination Ports   : Twel1/0/2
Encapsulation       : Native
  Ingress             : Disabled
```

Vérifiez l'entrée matérielle SPAN. Utilisez ID de session FED unique par configuration SPAN. Il peut y avoir jusqu'à 8 sessions FED configurées en même temps (des sessions FED 0 à 7).

```
C9500-SPAN# show platform software monitor session 1
Span Session 1 (FED Session 0):
  Type:          Local SPAN
  Prev type:     Local SPAN
  Ingress Src Ports: Twel1/0/1    <-- Hardware entry for source interface.
  Egress Src Ports:  Twel1/0/1    <-- Hardware entry for source interface.
  Ingress Local Src Ports: (null)
  Egress Local Src Ports: (null)
  Destination Ports:  Twel1/0/2    <-- Hardware entry for destination interface.
```

```

Ingress Src Vlans:
Egress Src Vlans:
Ingress Up Src Vlans: (null)
Egress Up Src Vlans: (null)
Src Trunk filter Vlans:
RSPAN dst vlan: 0
RSPAN src vlan: 0
RSPAN src vlan sav: 0
Dest port encap = 0x0000
Dest port ingress encap = 0xFFFFFFFFFFFFFFFF
Dest port ingress vlan = 0x0
SrcSess: 1 DstSess: 0 DstPortCfgd: 1 RspnDstCfg: 0 RspnSrcVld: 0
DstCliCfg: 0 DstPrtInit: 1 PsLclCfgd: 0
Flags: 0x00000031 PSPAN
Remote dest port: 0 Dest port group: 0
FSPAN disabled
FSPAN not notified

```

Collectez les numéros ASIC, Core et Port pour les ports SPAN source et de destination configurés. Le numéro de port est requis pour confirmer si l'interface SPAN source est correctement programmée et si la SPAN pointe vers la bonne interface SPAN de destination.

Astuce : Utilisez la nomenclature appropriée périphérique autonome **show platform software/hardware fed active** ou périphérique de pile **show platform software/hardware fed switch <number>**.

```

C9500-SPAN# show platform software fed active ifm mappings
Interface          IF_ID      Inst Asic Core Port SubPort Mac  Cntx LPN  GPN  Type Active
TwentyFiveGigE1/0/1  0x8       1  0  1  20  0    16  4  1  101  NIF  Y
TwentyFiveGigE1/0/2  0x9       1  0  1  21  0    17  5  2  102  NIF  Y

```

Le registre Doppler **IlePortLeSpanBitMapTable** est utilisé pour définir si un port est soumis à la fonctionnalité SPAN dans la direction d'entrée (RX). Pour confirmer que le port SPAN source configuré (port ASIC 20) est affecté à la **session FED** droite (session 0) :

```

C9500-SPAN# show platform hardware fed active fwd-asic register read register-name
IlePortLeSpanBitMapTable-20 asic 0 core 1
For asic 0 core 1

Module 0 - IlePortLeSpanBitMapTable[0][20]

ssbm                : 0x1      <-- Convert from Hexadecimal to Binary: 0b00000001. Bit 0 is
set.

```

Le mappage de bits de session SPAN est un registre de 8 bits. Chaque bit correspond à une session FED : Le bit de poids faible correspond à la session FED 0, le bit de poids fort correspond à la session FED 7. Ainsi, le nombre maximal de sessions SPAN prises en charge est de 8, comme mentionné précédemment.

Si une interface est configurée comme port source SPAN pour plusieurs sessions SPAN, toutes les sessions FED doivent apparaître dans le registre SSBM. Par exemple, SSBM avec la valeur 0x5 (0b00000101) signifie que l'interface est une source SPAN pour la session FED 0 et la session FED 2.

De même, le registre Doppler **ElePortLeSpanBitMapTable** register détermine si un port est soumis à la fonctionnalité SPAN dans la direction de sortie (TX). L'analyse est identique au registre **IlePortLeSpanBitMapTable**. Pour confirmer que le port SPAN source configuré (port ASIC 20) est

affecté à la **session FED** droite (session 0) :

```
C9500-SPAN# show platform hardware fed active fwd-asic register read register-name  
ElePortLeSpanBitMapTable-20 asic 0 core 1  
For asic 0 core 1
```

```
Module 0 - ElePortLeSpanBitMapTable[0][20]
```

```
ssbm : 0x1
```

Cela confirme que l'interface SPAN source est mappée à la session FED droite pour la direction RX et TX.

Avec l'**ID de session FED**, nous pouvons trouver le ou les ports de destination pour la SPAN dans le registre Doppler **AqmRepSpanPortMap**. Pour confirmer que la session FED 0 pointe vers le port de destination SPAN droit (port ASIC 21) :

```
C9500-SPAN# show platform hardware fed active fwd-asic register read register-name  
AqmRepSpanPortMap-0 asic 0 core 1  
For asic 0 core 1
```

```
Module 0 - AqmRepSpanPortMap[0][0]
```

```
cpuQueueNum : 0x0  
cpuSpanValid : 0x0  
indirectApPortMap : 0x0  
portMap0 : 0x200000 <-- Convert from Hexadecimal to Binary:  
0b00100000000000000000000000000000. Bit 21 is set.  
rcpPortMap : 0x0  
spanCtiLo : 0x0
```

Cela confirme que les paquets capturés avec la fonctionnalité SPAN doivent être affichés répliqués à partir de l'interface Tw1/0/2 (port ASIC 21). Si d'autres ports de destination SPAN sont configurés, ils sont affichés dans le registre **AqmRepSpanPortMap**.

Vérifier ERSPAN

Diagramme du réseau

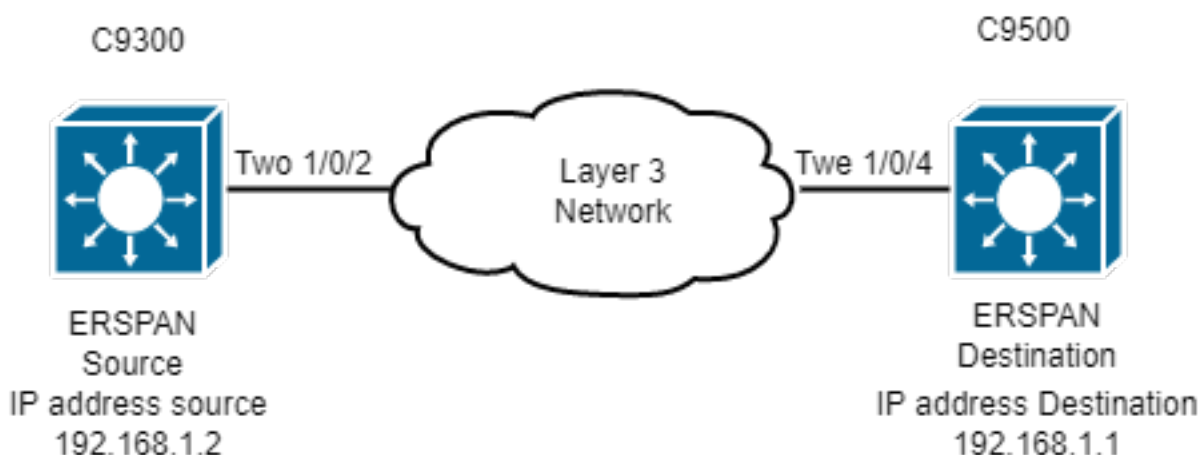

Note: Catalyst C9200 ne prend pas en charge ERSPAN.

Note: Une licence DNA-Advantage est requise.

Configuration ERSPAN

Source ERSPAN Device

```
C9300-ERSPAN# show run | section monitor
monitor session 1 type erspan-source
  source vlan 10
  destination
    erspan-id 3          <-- ERSPAN id must be identical on source and destination.
    ip address 192.168.1.1  <-- GRE tunnel destination IP (IP addr configured on ERSPAN
destination switch).
    origin ip address 192.168.1.2  <-- GRE tunnel source IP (IP addr configured on ERSPAN source
switch).
```

```
C9300-ERSPAN# show ip interface brief | exclude unassigned
Interface          IP-Address      OK? Method Status      Protocol
<snip>
Loopback0          192.168.1.2    YES NVRAM  up          up
```

Destination ERSPAN Device

```
C9500-ERSPAN# show run | section monitor
monitor session 1 type erspan-destination
destination interface Twel1/0/3
source
erspan-id 3 <-- ERSPAN id must be identical on source and destination.
ip address 192.168.1.1  <-- GRE tunnel destination IP (IP addr configured on ERSPAN destination
switch).
```

```
C9500-ERSPAN# show ip interface brief | exclude unassigned
Interface IP-Address OK? Method Status Protocol
<snip>
Loopback0 192.168.1.1 YES NVRAM up up
```

Périphérique source

Vérifier l'accessibilité entre l'IP d'origine et de destination

```
C9300-ERSPAN#ping 192.168.1.1 source 192.168.1.2
Type escape sequence to abort.
Sending 5, 100-byte ICMP Echos to 192.168.1.1, timeout is 2 seconds:
Packet sent with a source address of 192.168.1.2
!!!!
Success rate is 100 percent (5/5), round-trip min/avg/max = 1/1/2 ms
```

Programmation du logiciel Cisco IOS

Vérifiez dans le logiciel Cisco IOS l'entrée pour la session ERSPAN.

```
C9300-ERSPAN#show monitor session 1
Session 1
-----
Type          : ERSPAN Source Session
Status        : Admin Enabled
```

```
Source VLANs          :
  Both                : 10
Destination IP Address : 192.168.1.1
Destination ERSPAN ID  : 3
Origin IP Address     : 192.168.1.2
```

Programmation SHIM

Vérifiez ce que le logiciel envoie au matériel du programme (objet SHIM).

```
C9300-ERSPAN#show platform software monitor session 1
```

```
Span Session 1 (FED Session 0):
```

```
Type:          ERSPAN Source
Prev type:     Unknown
Ingress Src Ports:
Egress Src Ports:
Ingress Local Src Ports: (null)
Egress Local Src Ports: (null)
Destination Ports:
Ingress Src Vlans: 10      <-- Replicate Traffic.
Egress Src Vlans: 10      <-- Replicate Traffic.
Ingress Up Src Vlans: 10
Egress Up Src Vlans: 10
Src Trunk filter Vlans:
RSPAN dst vlan: 0
RSPAN src vlan: 0
RSPAN src vlan sav: 0
Dest port encap = 0x0000
Dest port ingress encap = 0x0000
Dest port ingress vlan = 0x0
SrcSess: 1  DstPortCfgd: 0  RspnDstCfg: 0  RspnSrcVld: 0      <-- Monitor session number.
DstCliCfg: 0  DstPrtInit: 0  PsLclCfgd: 0
Flags: 0x00000002 VSPAN
Remote dest port: 0  Dest port group: 0
FSPAN disabled
FSPAN not notified
ERSPAN Id      : 3          <-- Value match with the software setting.
ERSPAN Org Ip: 192.168.1.2 <-- Value match with the software setting.
ERSPAN Dst Ip: 192.168.1.1 <-- Value match with the software setting.
ERSPAN Ip Ttl: 255
ERSPAN State  : Enabled
ERSPAN Tun id: 77
```

Processeur de routage de Forwarding Manager

Vérifiez ce que le logiciel envoie au matériel du programme (couche RP FMAN).

```
C9300-ERSPAN#show platform software swspan switch active R0 source
```

```
Showing SPAN source table summary info
```

Sess-id	IF-type	IF-id	Sess-type	Dir
0	VLAN	10	ERSPAN SRC	Ingress
0	VLAN	10	ERSPAN SRC	Egress

```
C9300-ERSPAN#show platform software swspan switch active R0 source sess-id 0
```

```
Showing SPAN source detail info
```

```
Session ID : 0 Intf Type : VLAN Vlan id : 10 <-- Vlan entry
```

```
PD Sess ID : 0
```

```
Session Type : ERSPAN SRC
```

Direction : Ingress
Filter Enabled : No
ACL Configured : No
ERSPAN Enable : Yes

Session ID : 0
Intf Type : VLAN
Vlan id : 10 <-- Match with the Vlan/Interface SPAN.
PD Sess ID : 0
Session Type : ERSPAN SRC
Direction : Egress
Filter Enabled : No
ACL Configured : No
ERSPAN Enable : Yes

Forward Manager-Forwarding Processor

Vérifiez ce que le logiciel envoie au matériel du programme (couche FP FMAN).

C9300-ERSPAN#**show platform software swspan switch active F0 source**
Showing SPAN source table summary info

Sess-id	IF-type	IF-id	Sess-type	Dir
0	VLAN	10	ERSPAN SRC	Ingress
0	VLAN	10	ERSPAN SRC	Egress

C9300-ERSPAN#**show platform software swspan switch active F0 source sess-id 0**
Showing SPAN source detail info

Session ID : 0
Intf Type : VLAN
Vlan id : 10
PD Sess ID : 0
Session Type : ERSPAN SRC <-- Source Interface.
Direction : Ingress
Filter Enabled : No
ACL Configured : No
AOM Object id : 519
AOM Object Status : Done
Parent AOM object Id : 30
Parent AOM object Status : Done

Session ID : 0
Intf Type : VLAN
Vlan id : 10
PD Sess ID : 0
Session Type : ERSPAN SRC <-- Source Interface.
Direction : Egress
Filter Enabled : No
ACL Configured : No
AOM Object id : 520
AOM Object Status : Done
Parent AOM object Id : 30
Parent AOM object Status : Done

C9300-ERSPAN#**show platform software swspan switch active F0 counters** <-- Check for any error counters that increment on PI/PD/HW
Dump Switch SPAN FP operation counters <-- Operational Counters.

Source SPAN Config Counters

PI: Create 2 (err 0), Modify 0 (err 0), Delete 0 (err 0) <-- PI = platform independent (Software/IOS).

PD: Create 2 (err 0), Modify 0 (err 0), Delete 0 (err 0) <-- PD = platform dependent (SHIM/FMAN/FED).

HW: Create 2 (err 0), Modify 0 (err 0), Delete 0 (err 0) <-- HW = hardware (FED/ASIC).

Destination SPAN Config Counters

PI: Create 1 (err 0), Modify 0 (err 0), Delete 0 (err 0)

PD: Create 1 (err 0), Modify 0 (err 0), Delete 0 (err 0)

HW: Create 1 (err 0), Modify 0 (err 0), Delete 0 (err 0)

Filter SPAN Config Counters

PI: Create 0 (err 0), Modify 0 (err 0), Delete 0 (err 0)

PD: Create 0 (err 0), Modify 0 (err 0), Delete 0 (err 0)

HW: Create 0 (err 0), Modify 0 (err 0), Delete 0 (err 0)

Pilote du moteur de transfert

Vérifiez la couche qui programme l'ASIC (FED).

```
C9300-ERSPAN#show platform software fed switch active monitor 0
```

```
Session 0
```

```
-----
```

```
Session Type           : ERSPAN Source Session
Source Ports           : RX: None TX: None
Destination Ports      : None
Source VLANs           : VLAN-10
Destination VLANs      : VLAN-10
Source RSPAN VLAN      : 0
DST RSPAN VLAN         : 0
Encap                  : Native
Ingress Forwarding     : Disabled
Filter VLANs           : None
ERSPAN Enable          : 1           <-- 1 = On/Completed.
ERSPAN Hw Programmed   : 1           <-- 1 = On/Completed.
ERSPAN Mandatory Cfg   : 1           <-- 1 = On/Completed.
ERSPAN Id              : 3
Gre Prot               : 88be
MTU                    : 9000
Ip Tos                 : 0
Ip Ttl                 : 255
Cos                    : 0
Vrf Id                 : 0
Dst Ip                 : 192.168.1.1
```

```
Org Ip : 192.168.1.2
```

```
Dst Ipv6 : ::
```

```
Org Ipv6 : ::
```

```
SGT count : 0
```

```
SGT Tag(s) :
```

Vérifiez la programmation matérielle en tunnel (FED).

```
C9300-ERSPAN#show platform software fed switch active ifm interfaces tunnel
```

```
Interface                IF_ID                State
```

```
-----
```



```
sm handle [ASIC 0]: 0x7f00e0a56d08 index1:0x27 mtu_index/l3u_ri_index1:0x5
```

Decapsulation LE

```
C9300-ERSPAN#show platform hardware fed switch active fwd-asic abstraction print-resource-handle 0x00007f00e0a50a28 0 <-- DECAP.
```

```
Handle:0x7f00e0a50bd8 Res-Type:ASIC_RSC_L3IF_LE Res-Switch-Num:255 Asic-Num:255 Feature-ID:AL_FID_IFM Lkp-ftr-id:LKP_FEAT_INVALID ref_count:1
```

```
priv_ri/priv_si Handle: (nil)Hardware Indices/Handles: index0:0x28 mtu_index/l3u_ri_index0:0x0
```

```
sm handle [ASIC 0]: 0x7f00e0a559c8 index1:0x28 mtu_index/l3u_ri_index1:0x0
```

Exécutez Embedded Packet Capture sur le port de sortie vers le commutateur de destination. Un filtre peut être appliqué, utiliser l'IP source et de destination du tunnel GRE (le paquet est un paquet encapsulé).

```
Frame 1: 110 bytes on wire (880 bits), 110 bytes captured (880 bits) on interface 0
```

```
<snip>
```

```
Internet Protocol Version 4, Src: 192.168.1.2, Dst: 192.168.1.1 <-- ERSPAN IP HEADER.
```

```
0100 .... = Version: 4
```

```
.... 0101 = Header Length: 20 bytes (5)
```

```
Differentiated Services Field: 0x00 (DSCP: CS0, ECN: Not-ECT)
```

```
0000 00.. = Differentiated Services Codepoint: Default (0)
```

```
.... ..00 = Explicit Congestion Notification: Not ECN-Capable Transport (0)
```

```
Total Length: 96
```

```
Identification: 0x1018 (4120)
```

```
Flags: 0x00
```

```
0... .... = Reserved bit: Not set
```

```
.0.. .... = Don't fragment: Not set
```

```
..0. .... = More fragments: Not set
```

```
Fragment offset: 0
```

```
Time to live: 255
```

```
Protocol: Generic Routing Encapsulation (47) <-- GRE tunnel encapsulation.
```

```
Header checksum: 0x9c56 [validation disabled]
```

```
[Good: False]
```

```
[Bad: False]
```

```
Source: 192.168.1.2
```

```
<-- Source GRE IP tunnel.
```

```
Destination: 192.168.1.1
```

```
<-- Destination GRE IP tunnel.
```

```
Generic Routing Encapsulation (ERSPAN)
```

```
Flags and Version: 0x1000
```

```
0... .... = Checksum Bit: No
```

```
.0.. .... = Routing Bit: No
```

```
..0. .... = Key Bit: No
```

```
...1 .... = Sequence Number Bit: Yes
```

```
.... 0... = Strict Source Route Bit: No
```

```
.... .000 = Recursion control: 0
```

```
.... .... 0000 0... = Flags (Reserved): 0
```

```
.... .... .... .000 = Version: GRE (0)
```

```
Protocol Type: ERSPAN (0x88be)
```

```
<--ERSPAN enable.
```

```
Sequence Number: 0
```

```
Encapsulated Remote Switch Packet Analysis
```

```
0001 .... = Version: Type II (1)
```

```
.... 0000 0001 1000 = Vlan: 10
```

```
000. .... = Priority: 0
```

```
...1 .... = Unknown2: 1
```

```
.... 1... = Direction: Outgoing (1)
```

```
.... .0.. = Truncated: Not truncated (0)
```

```
.... ..00 0000 0011 = SpanID: 3 <--ERSPAN ID.
```

```
Unknown7: 00000002
```

```
Ethernet II, Src: Xerox_00:02:00 (00:00:08:00:02:00), Dst: Cisco_eb:90:68 (00:9e:1e:eb:90:68)
```

```
<snip>
```

```
(Internal data packet comes here, output truncated)
```

Périphérique de destination ERSPAN

Programmation du logiciel Cisco IOS

```
C9500-ERSPAN#show monitor session 1
```

```
Session 1
```

```
-----
```

```
Type                : ERSPAN Destination Session
Status              : Admin Enabled
Destination Ports   : Twel/0/3
Source IP Address   : 192.168.1.1
Source ERSPAN ID    : 3
```

Programmation SHIM

Vérifiez ce que le logiciel envoie au matériel du programme (objet SHIM).

```
C9500-ERSPAN#show platform software monitor session 1
```

```
Span Session 1 (FED Session 0):
```

```
Type:          ERSPAN Destination
Prev type:     Unknown
Ingress Src Ports:
Egress Src Ports:
Ingress Local Src Ports: (null)
Egress Local Src Ports: (null)
Destination Ports: Twel/0/3
Ingress Src Vlans:
Egress Src Vlans:
Ingress Up Src Vlans: (null)
Egress Up Src Vlans: (null)
Src Trunk filter Vlans:
RSPAN dst vlan: 0
RSPAN src vlan: 0
RSPAN src vlan sav: 0
Dest port encap = 0x0004
Dest port ingress encap = 0x0000
Dest port ingress vlan = 0x0
SrcSess: 0  DstSess: 1  DstPortCfgd: 1  RspnDstCfg: 0  RspnSrcVld: 0
DstCliCfg: 0  DstPrtInit: 1  PsLclCfgd: 0
Flags: 0x00000000
Remote dest port: 0  Dest port group: 0
FSPAN disabled
FSPAN not notified
ERSPAN Id      : 3
ERSPAN Dst Ip: 192.168.1.1
ERSPAN Vrf     : 0
```

Forward Manager-Forwarding Processor

Vérifiez ce que le logiciel envoie au matériel du programme (couche FMAN FP).

```
C9500-ERSPAN#show platform software swspan switch active r0 destination
```

```
Showing SPAN destination table summary info Sess-id IF-type IF-id Sess-type -----
----- 0 PORT 11 Local <-- IF-if 0xb maps to Twel/0/3 (Check under 'show
platform software fed active ifm mapping').
```

```
0          ERSPAN    ERSPAN    DST
```

C9500-ERSPAN#**show platform software swspan R0 destination sess-id 0**
Showing SPAN destination detail info

Session ID : 0
Intf Type : PORT
Port dpidx :11 <--Match with IF-id
PD Sess Id : 0
Session Type : Local <-- Type of monitor session
Ingress Fwd : No
Ingress Encape : Disabled
Ingress Vlan : 0
Encap Value : Replicate
RSPAN Vlan : 0

Session ID : 0
Intf Type : ERSPAN
Vlan id :
PD Sess Id : 0
Session Type : ERSPAN DST
ERSPAN Id : 3
ERSPAN Dst Ip: 192.168.1.1
ERSPAN Src Ip: 0.0.0.0
GRE Prot : 35006
MTU : 0
IP Tos : 0
IP Ttl : 255
Cos : 0
Vrf Id : 0
Tunnel Ifid: 38 <-- 38 in Decimal is 0x26 in Hex which is the IF_ID of Tunnel1
ERSPAN En : TDL_TRUE

Forward Manager-Forwarding Processor

Vérifiez ce que le logiciel envoie au matériel du programme (couche FMAN FP).

C9500-ERSPAN#**show platform software swspan switch active F0 counters** <-- (check for any error counters on PI/PD/HW).

Dump Switch SPAN FP operation counters

Source SPAN Config Counters

PI: Create 0 (err 0), Modify 0 (err 0), Delete 0 (err 0) <-- **PI = platform independent (Software/IOS)**.
PD: Create 0 (err 0), Modify 0 (err 0), Delete 0 (err 0) <-- **PD = platform dependent (SHIM/FMAN/FED)**.
HW: Create 0 (err 0), Modify 0 (err 0), Delete 0 (err 0) <-- **HW = hardware (FED/ASIC)**.

Destination SPAN Config Counters

PI: Create 10 (err 0), Modify 6 (err 0), Delete 4 (err 0)
PD: Create 4 (err 0), Modify 0 (err 0), Delete 2 (err 0)
HW: Create 4 (err 0), Modify 0 (err 0), Delete 2 (err 0)

Filter SPAN Config Counters

PI: Create 0 (err 0), Modify 0 (err 0), Delete 0 (err 0)
PD: Create 0 (err 0), Modify 0 (err 0), Delete 0 (err 0)
HW: Create 0 (err 0), Modify 0 (err 0), Delete 0 (err 0)

C9500-ERSPAN#**show platform software swspan switch active F0 destination**

Showing SPAN destination table summary info

Sess-id	IF-type	IF-id	Sess-type
0	PORT	11	Local
0	VLAN	0	ERSPAN DST

Pilote du moteur de transfert

Vérifiez la couche qui programme l'ASIC (FED).

```
C9500-ERSPAN#show platform software fed switch active monitor 0
```

```
Session 0
```

```
-----  
Session Type           : ERSPAN Destination Session  
Source Ports : RX: None TX: Tunnel1000000000 Destination Ports : TwentyFiveGigE1/0/3  
Source VLANs          : None  
Destination VLANs     : None  
Source RSPAN VLAN     : 0  
DST RSPAN VLAN       : 0  
Encap                 : Replicate  
Ingress Forwarding    : Disabled  
Filter VLANs         : None  
ERSPAN Enable       : 1  
ERSPAN Hw Programmed : 1  
ERSPAN Mandatory Cfg : 1  
ERSPAN Id         : 3  
Ip Tos                : 0 (DSCP:0)  
Ip Ttl                : 0  
Cos                  : 0  
Vrf Id               : 0  
Tunnel IfId       : 38 <-- 38 in Decicmal is 0x26 in Hex which is the IF_ID  
of Tunnel1  
Dst Ip           : 192.168.1.1  
Org Ip               : 0.0.0.0  
SGT count            : 0  
SGT Tag(s)          :
```

Vérifiez la programmation matérielle en tunnel (FED).

```
C9500-ERSPAN#show platform software fed switch active ifm interfaces tunnel
```

```
Interface IF_ID State
```

```
-----  
Tunnel1000000000 0x00000026 READY
```

```
C9500-ERSPAN#show platform software fed switch active ifm if-id 0x00000026
```

```
Interface IF_ID : 0x0000000000000026  
Interface Name : Tunnel1000000000  
Interface Block Pointer : 0x7f2cd48e9958  
Interface Block State : READY  
Interface State : Enabled  
Interface Status : ADD  
Interface Ref-Cnt : 5  
Interface Type : TUNNEL  
Unit : 0 SNMP IF Index : 0 Encap L3If LE Handle : 0x7f2cd4904e08 <-- Hardware handle info  
(used to check final Hardware program state).  
Decap L3If LE Handle : 0x7f2cd48dabc8 <-- Hardware handle info (used to check final Hardware  
program state).
```

```

Tunnel Mode      : 0 [gre]                <-- Tunnel Protocol Enable.
Hw Support       : Yes
Tunnel Vrf       : 0
IPv4 MTU         : 0
IPv6 MTU         : 0
IPv4 VRF ID     : 0
IPv6 VRF ID     : 0
Protocol flags   : 0x0001 [ ipv4 ]
Misc flags       : 0x0000 [ None ]
ICMPv4 flags    : 0x03 [ unreachable redirect ]
ICMPv6 flags    : 0x03 [ unreachable redirect ]

```

Port Information

```

Handle ..... [0xd4000043]
Type ..... [L3-Tunnel] Identifier ..... [0x26] Unit ..... [38] Port Logical
Tunnel Subblock Encap-L3if1e.....[0x7f2cd4904e08] <-- Same number as previous highlighted
output.
Decap-L3if1e.....[0x7f2cd48dabc8] <-- Same number as previous highlighted output.
decap-portle.....[0x0]
RI-decap.....[0x7f2cd49615d8] <-- Same number as previous highlighted output.
SI-decap.....[0x7f2cd4958dd8] <-- Same number as previous highlighted output.
Decap-Tcam_handle..[0x7f2cd46eee08] <-- Same number as previous highlighted output.
Tunnel_capability..[0x3]
Encap-RCP-PMAP.....[0x0]
GPN.....[0]
<snip>

```

```

C9500-ERSPAN#show platform software fed switch active ifm mappings l3if-1e | include L3IF|Tunnel
L3IF_LE          Interface          IF_ID          Type
0x00007f2cd48dabc8  Tunnel1000000000  0x00000026    DECAP_L3_LE
<-- L3IF + IF_ID (DECAP) match here.
0x00007f2cd4904e08  Tunnel1000000000  0x00000026    ENCAP_L3_LE
<-- L3IF + IF_ID (ENCAP) match here.

```

Encapsulation LE

```

C9500-ERSPAN#show platform hardware fed switch active fwd-asic abstraction print-resource-handle
0x7f2cd4904e08 0 <--ENCAP
Handle:0x7f2cd4904e08 Res-Type:ASIC_RSC_L3IF_LE Res-Switch-Num:255 Asic-Num:255 Feature-
ID:AL_FID_IFM Lkp-ftr-id:LKP_FEAT_INVALID ref_count:1
priv_ri/priv_si Handle: (nil)Hardware Indices/Handles: index0:0x27 mtu_index/l3u_ri_index0:0x2
sm handle [ASIC 0]: 0x7f2cd46ece38 index1:0x27 mtu_index/l3u_ri_index1:0x4

```

=====

Decapsulation LE

```

C9500-ERSPAN#show platform hardware fed switch active fwd-asic abstraction print-resource-handle
0x7f2cd48dabc8 0 <--DECAP
Handle:0x7f2cd48dabc8 Res-Type:ASIC_RSC_L3IF_LE Res-Switch-Num:255 Asic-Num:255 Feature-
ID:AL_FID_IFM Lkp-ftr-id:LKP_FEAT_INVALID ref_count:1
priv_ri/priv_si Handle: (nil)Hardware Indices/Handles: index0:0x28 mtu_index/l3u_ri_index0:0x0
sm handle [ASIC 0]: 0x7f2cd46d91c8 index1:0x28 mtu_index/l3u_ri_index1:0x0

```

Rewrite Index (decapsulation)

```

C9500-ERSPAN#show platform hardware fed switch active fwd-asic abstraction print-resource-handle
0x7f2cd49615d8 1 <-- RI-decap
Handle:0x7f2cd49615d8 Res-Type:ASIC_RSC_RI Res-Switch-Num:255 Asic-Num:255 Feature-ID:AL_FID_GRE
Lkp-ftr-id:LKP_FEAT_INVALID ref_count:1
priv_ri/priv_si Handle: 0x7f2cd48daf28Hardware Indices/Handles: index0:0x16
mtu_index/l3u_ri_index0:0x0 index1:0x16 mtu_index/l3u_ri_index1:0x0

```

Features sharing this resource:107 (1)]
Cookie length: 56
00 00 00 00 00 00 00 00 28 00 00 00 00 00 00 00 00 00 00 00 00 00 00 00 00 00 00 00 01 6b 33 00
00 00

Detailed Resource Information (ASIC# 0) -----
Rewrite Data Table Entry, ASIC#:0 RI:22 Rewrite_type:AL_RRM_REWRITE_IPV4_ERSPAN2_DECAP(61)
Mapped_rii:TUNNEL_IPv4Erspan_DECAP(83) **L3IF LE Index: 40** <-- 64 in Decimal is 0x40
in Hex which matches Decap LE index seen above

Detailed Resource Information (ASIC# 1)

Rewrite Data Table Entry,
ASIC#:1 RI:22 Rewrite_type:AL_RRM_REWRITE_IPV4_ERSPAN2_DECAP(61)
Mapped_rii:TUNNEL_IPv4Erspan_DECAP(83)

L3IF LE Index: 40 =====

Station Index (decapsulation)

C9500-ERSPAN#show platform hardware fed switch active fwd-asic abstraction print-resource-handle
0x7f2cd4958dd8 1 <-- SI-decap

Handle:0x7f2cd4958dd8 Res-Type:ASIC_RSC_SI Res-Switch-Num:255 Asic-Num:255 Feature-ID:AL_FID_GRE
Lkp-ftr-id:LKP_FEAT_INVALID ref_count:1
priv_ri/priv_si Handle: 0x7f2cd49615d8Hardware Indices/Handles: index0:0xae
mtu_index/l3u_ri_index0:0x0 index1:0xae mtu_index/l3u_ri_index1:0x0

Features sharing this resource:107 (1)]
Cookie length: 56
00 00 00 00 00 00 00 00 28 00 00 00 00 00 00 00 00 00 00 00 00 00 00 00 00 00 00 00 01 6b 36 00
00 00

Detailed Resource Information (ASIC# 0) ----- Station Index
(SI) [0xae]

RI = 0x16 DI = 0x5012 stationTableGenericLabel = 0 stationFdConstructionLabel = 0x7
lookupSkipIdIndex = 0x15 rcpServiceId = 0 dejaVuPreCheckEn = 0 Replication Bitmap: LD Detailed
Resource Information (ASIC# 1) ----- Station Index (SI)

[0xae]
RI = 0x16 DI = 0x5012 stationTableGenericLabel = 0 stationFdConstructionLabel = 0x7
lookupSkipIdIndex = 0x15 rcpServiceId = 0 dejaVuPreCheckEn = 0 Replication Bitmap: CD
=====

Tunnel Decap (TCAM)

C9500-ERSPAN#show platform hardware fed switch active fwd-asic abstraction print-resource-handle
0x7f2cd46eee08 1 <-- Decap-Tcam_handle.

Handle:0x7f2cd46eee08 Res-Type:ASIC_RSC_HASH_TCAM Res-Switch-Num:0 Asic-Num:255 Feature-
ID:AL_FID_GRE Lkp-ftr-id:LKP_FEAT_TT_IPV4_GRE ref_count:1
priv_ri/priv_si Handle: (nil)Hardware Indices/Handles: handle [ASIC: 0]: 0x7f2cd48db018
Detailed Resource Information (ASIC# 0) ----- Number of HTM

Entries: 3 **Entry 0: (handle 0x7f2cd48db018)**

Labels	Port	Vlan	L3If	Group
M:	0000	0000	0000	0000
V:	0000	0000	0000	0000

M: ffffffff 00000000 00000000 000003ff 00000000 00000100 01000000 00000fff
3f000000 V: **c0a80101** 00000000 00000000 00000003 00000000 00000100 01000000 00000000 <--
c0a80101 in Hex maps to 192.168.1.1
00000000

GREv4 Dst Src Key C S R D E F VRF Fl L3P GreP Misc RCPSVCId
M: ffffffff 00000000 00000000 0 0 0 0 0 1 000 0 00 0000 00 3f <-- F=1

Forwarding

V: **c0a80101** 00000000 00000000 0 0 0 0 0 1 000 0 00 0000 00 00
Action: 00000100 06000000 00000000 00000000 00000000 00000000 000000ad 00000000

00000000 00000000
RL2 RL3 ACF SPK CLPC LKV PRI STL LPC ADC LKI SI

0 1 0 0 0 0 6 0 0 0 0 ad <-- Hexadecimal
value for Station Index.

Start/Skip Word: 0x00000003
Start Feature, Terminate

Entry 1: (handle 0x7f2cd495c3f8)

Labels Port Vlan L3If Group
M: 0000 0000 0000 0000
V: 0000 0000 0000 0000

M: ffffffff 00000000 00000000 000003ff 00000000 00000100 00000000 000a0000
3f000000
V: c0a80101 00000000 00000000 00000003 00000000 00000100 00000000 00080000
00000000

GREv4 Dst Src Key C S R D E F VRF Fl L3P GreP Misc RCPSVCId
M: ffffffff 00000000 00000000 0 0 0 0 0 0 000 a 00 0000 00 3f
V: c0a80101 00000000 00000000 0 0 0 0 0 0 000 8 00 0000 00 00
Action: 00000100 06000000 00000000 00000000 00000000 00000000 000000ad 00000000
00000000 00000000

RL2 RL3 ACF SPK CLPC LKV PRI STL LPC ADC LKI SI

0 1 0 0 0 0 6 0 0 0 0 ad

Start/Skip Word: 0x00000000
No Start, Terminate

Entry 2: (handle 0x7f2cd46ef568)

Labels Port Vlan L3If Group
M: 0000 0000 0000 0000
V: 0000 0000 0000 0000

M: ffffffff 00000000 00000000 000003ff 00000000 00000100 00000000 00020fff
00000000
V: c0a80101 00000000 00000000 00000003 00000000 00000100 00000000 00000000
00000000

GREv4 Dst Src Key C S R D E F VRF Fl L3P GreP Misc RCPSVCId
M: ffffffff 00000000 00000000 0 0 0 0 0 0 000 2 00 0000 00 00
V: c0a80101 00000000 00000000 0 0 0 0 0 0 000 0 00 0000 00 00
Action: 00000100 06000000 00000000 00000000 00000000 00000000 000000ae 00000000
00000000 00000000

RL2 RL3 ACF SPK CLPC LKV PRI STL LPC ADC LKI SI

0 1 0 0 0 0 6 0 0 0 0 ae <-- Hexadecimal
value for Station Index.

Start/Skip Word: 0x00000000
No Start, Terminate

=====

C9500-ERSPAN#show platform hardware fed switch active fwd-asic resource asic 0 station-index
range 0xab 0xab

ASIC#0:
Station Index (SI) [0xad]
RI = 0x14
DI = 0x505a <-- Destination Index
stationTableGenericLabel = 0
stationFdConstructionLabel = 0x7
lookupSkipIdIndex = 0x15

```
rcpServiceId = 0xd
dejaVuPreCheckEn = 0
Replication Bitmap: LD
```

```
C9500-ERSPAN#show platform hardware fed switch active fwd-asic resource asic 0 station-index
range 0xae 0xae
```

```
Station Index (SI) [0xae]
RI = 0x16
DI = 0x5012 <-- Destination Index
stationTableGenericLabel = 0
stationFdConstructionLabel = 0x7
lookupSkipIdIndex = 0x15
rcpServiceId = 0
dejaVuPreCheckEn = 0
Replication Bitmap: LD
```

```
C9500-ERSPAN#show platform hardware fed switch active fwd-asic resource asic 0 destination-index
range 0x505a 0x505a
```

```
Destination index = 0x505a DI_RCP_PORT2
pmap = 0x00000000 0x00000000
cmi = 0x0
```

```
rcp_pmap = 0x2
al_rsc_cmi
CPU Map Index (CMI) [0]
ctiLo0 = 0
ctiLo1 = 0
ctiLo2 = 0
cpuQNum0 = 0
cpuQNum1 = 0
cpuQNum2 = 0
npuIndex = 0
stripSeg = 0
copySeg = 0
```

```
C9500-ERSPAN#show platform hardware fed switch active fwd-asic resource asic 0 destination-index
range 0x5012 0x5012
```

```
ASIC#0:
Destination Index (DI) [0x5012]
portMap = 0x00000000 00000000
cmi1 = 0
rcpPortMap = 0x1
```

```
CPU Map Index (CMI) [0]
ctiLo0 = 0
ctiLo1 = 0
ctiLo2 = 0
cpuQNum0 = 0
cpuQNum1 = 0
cpuQNum2 = 0
npuIndex = 0
stripSeg = 0
copySeg = 0
```

Débogages et suivis pertinents

Cisco IOS XE

```
debug monitor all
debug platform monitor
```

FMAN-RP

```
set platform software trace forwarding-manager switch <> R0 switch-span verbose  
show platform software trace message forwarding-manager switch <> R0
```

FMAN-FP

```
set platform software trace forwarding-manager switch <> F0 switch-span verbose  
show platform software trace message forwarding-manager switch <> F0
```

NOURRIR

```
set platform software trace fed switch <> swspan verbose  
set platform software trace fed switch <> asic_spn verbose  
set platform software trace fed switch <> acl verbose (Useful when ip/ipv6 filter is  
configured)  
show platform software trace message fed switch <>
```

Informations connexes

- [Support et documentation techniques - Cisco Systems](#)
- [Guide de configuration de la gestion du réseau, Cisco IOS XE Amsterdam 17.3.x \(commutateurs Catalyst 9500\) ERSPAN](#)
- [Guide de configuration de la gestion du réseau, Cisco IOS XE Amsterdam 17.3.x \(commutateurs Catalyst 9500\) SPAN](#)
- [Blog : Comment le TAC Cisco transforme la documentation et simplifie le libre-service](#)

À propos de cette traduction

Cisco a traduit ce document en traduction automatisée vérifiée par une personne dans le cadre d'un service mondial permettant à nos utilisateurs d'obtenir le contenu d'assistance dans leur propre langue.

Il convient cependant de noter que même la meilleure traduction automatisée ne sera pas aussi précise que celle fournie par un traducteur professionnel.