



Overview

The Cisco Catalyst 9800-80 Wireless Controller is an 80-G wireless controller that occupies two rack unit space and supports a single Ethernet Port Adapter (EPA) slot, and eight built-in 10-GE or 1-GE interfaces.

The Cisco Catalyst 9800-80 Wireless Controller portfolio comes with a 30-G Crypto processor that aggregates services at scale.

- [Summary of Cisco Catalyst 9800-80 Wireless Controller, on page 1](#)
- [Cisco Product Identification Standard, on page 7](#)
- [Serial Number and PID or VID Label Location, on page 9](#)

Summary of Cisco Catalyst 9800-80 Wireless Controller

The Cisco Catalyst 9800-80 Wireless Controller supports:

- Up to 64 GB of DDR4 error-correcting code-protected field-replaceable memory, with single-bit error correction and multi-bit error detection.
- A fixed forwarding processor with up to 100 Gbps sustained forwarding data traffic through the chassis.
- Up to 30 Gbps security and crypto processing through a dedicated security processor.
- RJ-45 console ports and a mini USB console port.
- 32 GB internal bootflash storage.
- One copper Ethernet 10/100/1000 Mbps network management port.
- An embedded USB (eUSB) flash module that supports 32 GB of nonvolatile Flash storage.
- Two USB 3.0 ports that are backward compatible with USB 2.0.
- SATA hard disk.
- Eight built-in 10 GE SFP+ interfaces.



Note The Te0/0/6 and Te0/0/7 ports support 10 GE and 1 GE SFP+ interfaces.

- One Ethernet Port Adapter (EPA) bay.

- Stratum 3E network clocking per GR-1244-CORE, using 1 GE, 10 GE, or EPA interfaces as timing sources.
- LED indicators for Ethernet and console status, as well as visual system state indications.
- Command-line interface (CLI), alarm, network management, logging, statistics aggregation, and on-board failure logging (OBFL).
- Environmental chassis management.
- 80 Mb ternary content-addressable memory (TCAM).
- Field-replaceable units (FRU).

See Chapter 2, **Supported Hardware Components** for information on supported FRUs.

Front View

The following figure shows the front of the Cisco Catalyst 9800-80 Wireless Controller.

Figure 1: Cisco Catalyst 9800-80 Wireless Controller Front View

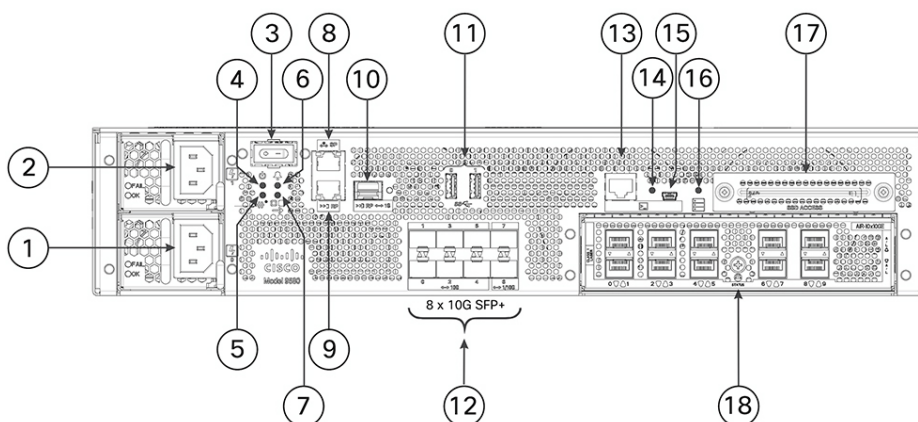

1	Power supply (PEM 0)	10	RP— 1-GE SFP port
2	Power supply (PEM 1)	11	USB ports 0 and 1
3	Power (PWR) switch	12	Bay 0—8 X 10GE SFP+ ports (Fixed EPA)
4	PWR— Power LED	13	CON— RJ-45 compatible console port
5	SYS— System LED	14	LINK— RJ-45 connector LED
6	ALM— Alarm LED	15	CON— Mini USB console port
7	HA— High-Availability LED	16	SSD— SSD activity LED
8	SP— RJ-45 10/100/1000 management Ethernet port	17	SSD Access

9	RP— RJ-45 10/100/1000 redundancy Ethernet port	18	Bay 1 or Hot-Swap EPA
---	--	----	-----------------------

Two power supplies (AC or DC) are accessed from the front of the controller and are hot-swappable.



Warning Never install an AC power module and a DC power module in the same chassis.

Statement 1050

Built-In SFP and SFP+ Ports

The following figure shows the port numbering for the built-in ports.

Figure 2: Cisco Catalyst 9800-80 Wireless Controller Port Numbering

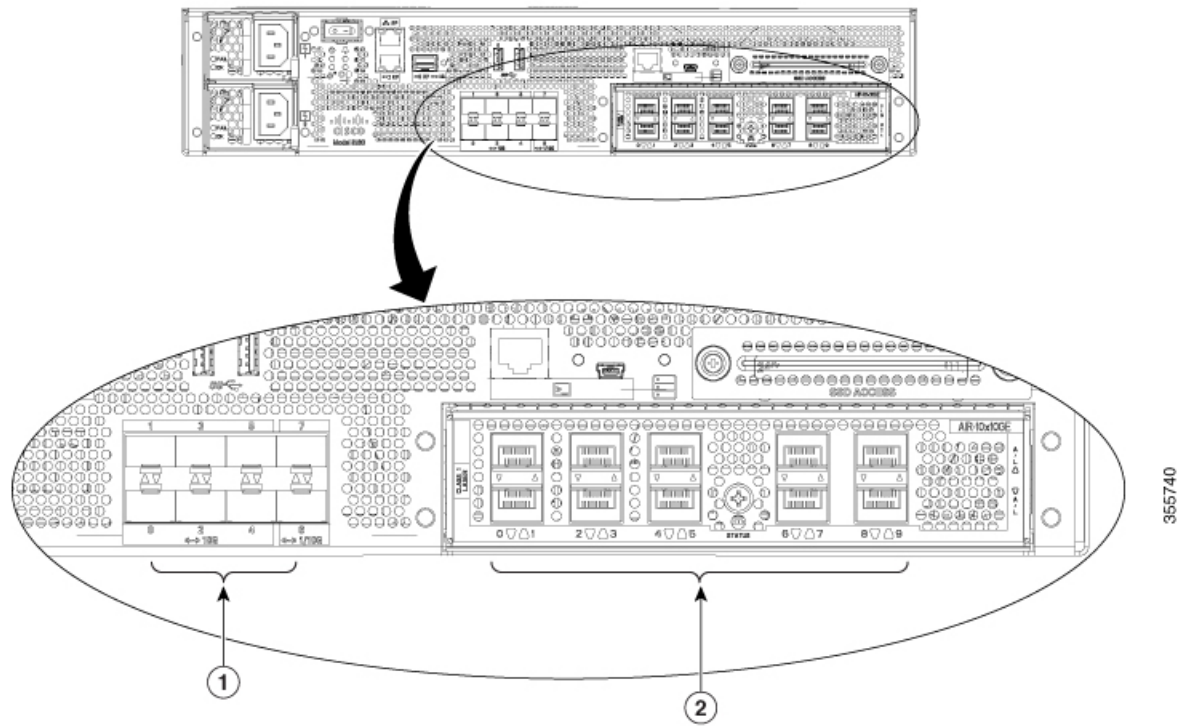

1	Bay 0—Two ports in Bay 0 support 1-GE or 10-GE. The rest six ports support 10GE.	2	Bay 1—is blank by default. You may add supported EPA modules.
---	--	---	---

The port LEDs behave as follows:

- Off—Indicates the port is not enabled by software.
- Amber—Indicates the port is enabled by software but there is a problem with the link.
- Green—Indicates the port is enabled by software and there is valid link.

Management and Storage Connections

The following figure shows the management and storage connections for the Cisco Catalyst 9800-80 Wireless Controller.

Figure 3: Management and Storage Connections for the Cisco Catalyst 9800-80 Wireless Controller

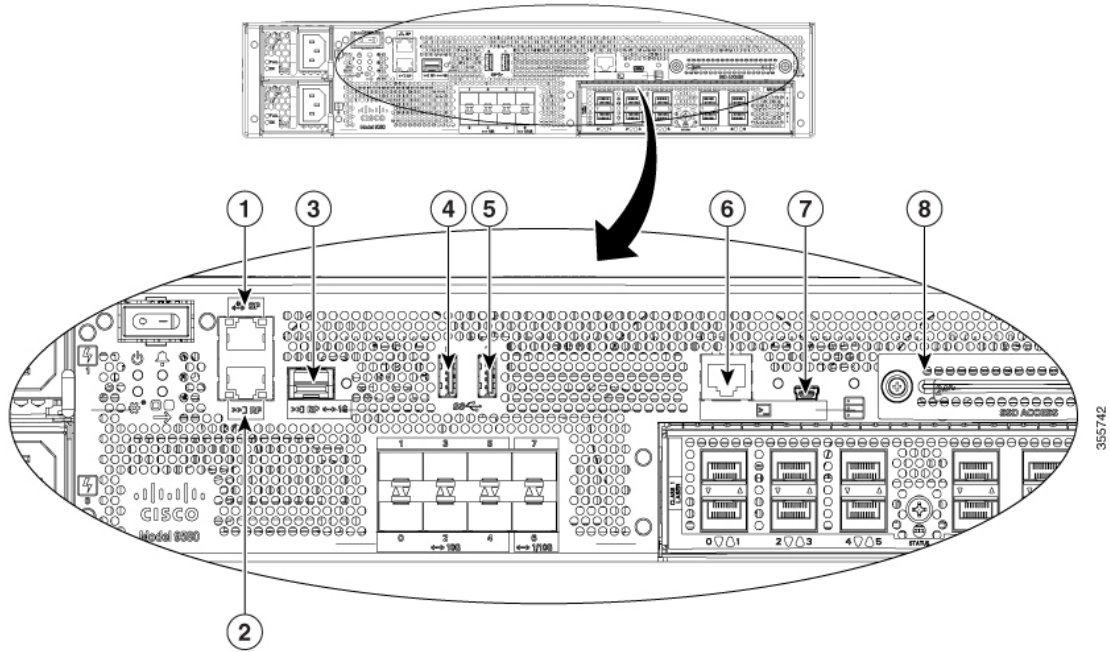







1	MGMT— RJ-45 10/100/1000 management Ethernet port.	5	USB port 1
2	RDCY— RJ-45 10/100/1000 redundancy Ethernet port.	6	CON— Mini USB connector console port.
3	RDCY— 1-GE SFP+ port.	7	CON— RJ-45 compatible console port.
4	USB port 0	8	SSD Access

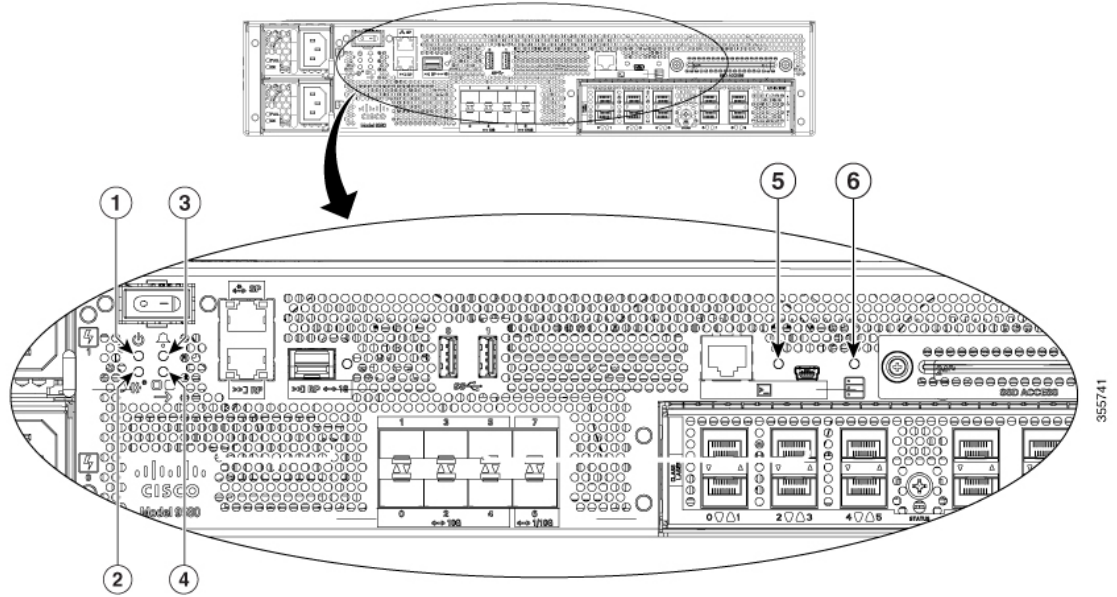







LEDs

The following figure shows the LEDs on the front panel of the Cisco Catalyst 9800-80 Wireless Controller.

Figure 4: Cisco Catalyst 9800-80 Wireless Controller LEDs



No.	LED Label	Description	LED Color	Behavior
1	PWR	Power	Green 	If all the power rails are based on the specification.
2	SYS	System	On 	Remains ON during IOS boot complete.
			Blinking Green 	Remains blinking when IOS booting is in progress.
			Amber 	Remains ON during system crash.
			Blinking Amber 	Remains blinking during secure boot failure.
			Off 	Remains OFF during ROMMON boot.

No.	LED Label	Description	LED Color	Behavior
3	ALM	Alarm	Green 	Remains ON during ROMMON boot complete.
			Blinking Green 	Remains blinking when system upgrade is in progress.
			Amber 	Remains ON during ROMMON and SYSTEM bootups.
			Blinking Amber 	Remains blinking during temperature error and secure boot failure.
			Red	Indicates that the system detects critical warnings.
			Off	Remains OFF during IOS boot. Normal Operation
4	HA	High Availability	Green 	Remains ON when HA is active.
			Blinking Green 	Remains blinking when HA Standby Hot.
			Amber 	Blinks slowly when booted or HA Standby Cold.
			Blinks Fast	Blinks fast during HA maintenance.
5		USB console enabled	Green 	Indicates that the mini USB connector is used as the console.
6	SSD	SSD Activity	Green 	Remains ON during the SSD activity.

Rear View

The following figure shows the rear of the Cisco Catalyst 9800-80 Wireless Controller.

Figure 5: Cisco Catalyst 9800-80 Wireless Controller Rear View

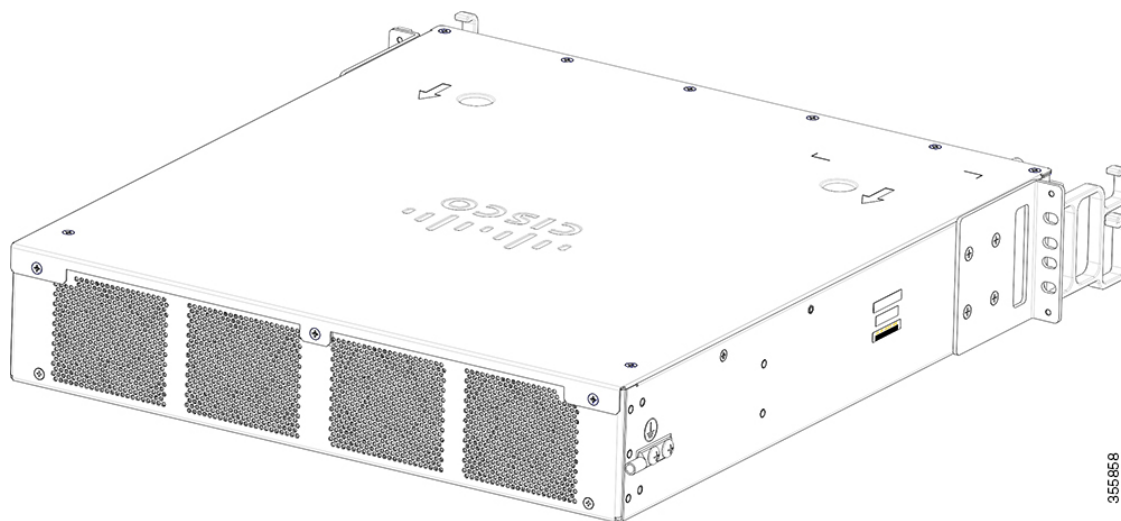

The chassis has a front-to-rear airflow. Four internal fans draw cooling air in through the front of the chassis and across internal components to maintain an acceptable operating temperature. The fans are located at the rear of the chassis. The fans are numbered from 0 to 3, right to left.



Caution The power supplies used in Cisco Catalyst 9800-80 Wireless Controllers are different and they should not be mixed or swapped. The size and structural dimensions are the same, therefore they both look alike. It would be hazardous, if you accidentally inserted the wrong power supply into the PEM slot.

Cisco Product Identification Standard

This section describes the Cisco products and services product identification standard. This feature provides you with the ability to effectively integrate and manage Cisco products in your network and business operations.

Unique Device Identifier

The Unique Device Identifier (UDI) is the Cisco product identification standard for hardware products. A product identification standard removes barriers to enterprise automation and can help you reduce operating expenses.

The UDI provides a consistent electronic, physical, and associated business-to-business information product identification standard.

The UDI is a combination of five data elements. The following table lists the UDI elements.

Table 1: UDI Elements

UDI Data Element	Electronic Visibility	Physical Visibility	Description

PID	Yes	Yes	Product ID, also known as product name, model name, product number
VID	Yes	Yes	Version ID
SN	Yes	Yes	Serial number, the unique instance of the PID
Entity Name	Yes	—	Type, such as chassis, slot, or power supply
Product Description	Yes	—	Additional product information

The combination of serial number and product ID (PID) is unique and consistent across all Cisco products. The PID that is coded on hardware is called a base product identifier.

Additional orderable PIDs can be associated to a base PID. For instance, an orderable PID may describe a packaging configuration for a product or a bundled group of products sold, tested, and shipped together. Specific unique device identifier (UDI) benefits include the following:

- Identifies:
 - Individual Cisco products in your networks
 - PIDs and serial numbers for service and replaceable products
 - Version IDs (VIDs) for product version visibility
- Facilitates discovery of products subject to recall or upgrade
- Enhances inventory automation of Cisco products

The Cisco product identification standard provides the following features:

- Version visibility—Cisco continuously improves products through feature additions. Product changes are indicated by incrementing the VID, which provides version visibility to help you understand and manage product changes. VID management ensures consistency of changes from product to product.
- Operating expense reduction—Cisco UDIs provide accurate and detailed network inventory information; identifying each Cisco product in a network element through a standard interface. Cisco operating systems can view and use this data, allowing you to automate your electronic inventory.
- Consistency across product layers—The UDIs are embedded in the hardware products and cannot be overwritten. Operating and management systems discover UDIs through standard interfaces and display UDIs in standard outputs. Standard interfaces include the IETF standard ENTITY-MIB.

show diag chassis eeprom detail Command

The **show diag chassis eeprom** command displays the PID, VID, PCB serial number, hardware revision, and other such information.

The following is sample output from the **show diag chassis eeprom** command:

```
WLC# show diag chassis eeprom
MIDPLANE EEPROM data:

Product Identifier (PID) : C9800-80-K9
Version Identifier (VID) : V01
PCB Serial Number      : xxxxxxxxxxx
```



```

Top Assy. Part Number   : 68-8888-68
Hardware Revision      : 0.2
Asset ID              :
CLEI Code             : UNASSIGNED
Power/Fan Module P0 EEPROM data:

Product Identifier (PID) : C9800-AC-750W
Version Identifier (VID) : V01
PCB Serial Number       : xxxxxxxxxxxx
Hardware Revision       : 1.0
Asset ID                :
CLEI Code               : xxxxxxxxxxxx
Power/Fan Module P1 EEPROM data is not initialized

```



Note Common Language Equipment Identification (CLEI) code is a ten-digit character code that identifies a specific product. A CLEI code is applied to each part within a Cisco Catalyst 9800-80 Wireless Controller as they are programmed in manufacturing for shipment to customers.

show license udi Command

The **show license udi** command displays UDI information.

The following is sample output from the **show license udi** command:

```

WLC# show license udi
SlotID  PID                SN                UDI
-----
*       C9800-80-K9        xxxxxxxxxxxx      C9800-80-K9:xxxxxxxxxx

```



Note For complete information on the product identification standard, see <https://www.cisco.com/c/en/us/products/unique-device-identifier-udi.html>.

Serial Number and PID or VID Label Location

The following figures show the location of the serial number and the PID/VID label on the Cisco Catalyst 9800-80 Wireless Controller.

Figure 6: Cisco Catalyst 9800-80 Wireless Controller Serial Number and PID/VID Label Location

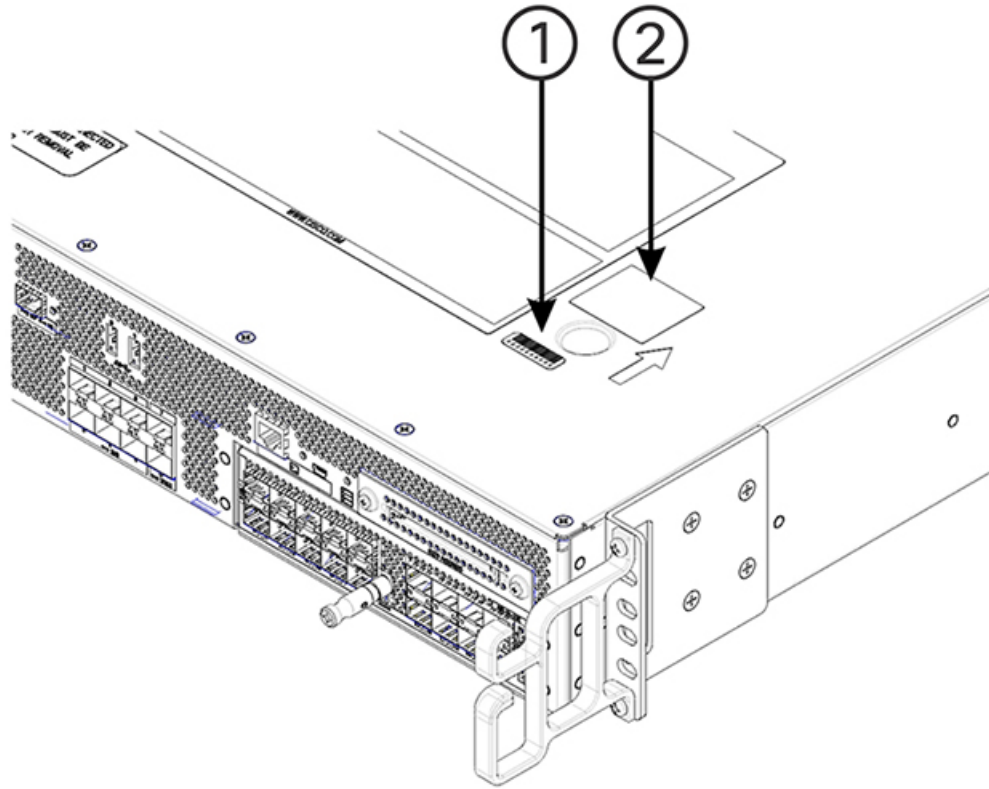

1	Serial Number	2	PID/VID Label
---	---------------	---	---------------