



Overview

The Cisco Catalyst 9800-40 Wireless Controller is a 40-G wireless controller that occupies one rack unit space and populates four ports. The Cisco Catalyst 9800-40 Wireless Controller portfolio comes with a modular Crypto Coprocessor that aggregates services at scale.

The Cisco Catalyst 9800-40 Wireless Controller offers a compact form factor that consumes less rack space and power while offering 40 Gbps forwarding throughput.

- [Summary of Cisco Catalyst 9800-40 Wireless Controller, on page 1](#)
- [Cisco Product Identification Standard, on page 7](#)
- [Serial Number and PID/VID Label Location, on page 9](#)

Summary of Cisco Catalyst 9800-40 Wireless Controller

The Cisco Catalyst 9800-40 Wireless Controller supports:

- Up to 32 GB of DDR3 error-correcting code-protected field-replaceable memory, with single-bit error correction and multi-bit error detection.
- A fixed forwarding processor with up to 40 Gbps sustained forwarding data traffic through the chassis.
- Up to 30 Gbps security and crypto processing through a dedicated security processor.
- RJ-45 console ports and a mini USB console port.
- 32 GB internal bootflash storage.
- One copper Ethernet 10/100/1000 Mbps network management port.
- An embedded USB (eUSB) flash module that supports 32 GB of nonvolatile Flash storage.
- Two USB 3.0 ports that are backward compatible with USB 2.0.
- SATA hard disk.
- Four built-in 10 GE SFP+ ports (capable of SyncE and MACsec).
- Stratum 3E network clocking per GR-1244-CORE, using 10 GE, or 1 GE interfaces as timing sources
- LED indicators for Ethernet and console status, as well as visual system state indications.
- Command-line interface (CLI), alarm, network management, logging, statistics aggregation, and on-board failure logging (OBFL).

- Environmental chassis management.
- 80 Mb ternary content-addressable memory (TCAM).
- Field-replaceable units (FRU).

See Chapter 2, **Supported Hardware Components** for information on supported FRUs.

Front View

The following figure shows the front of the Cisco Catalyst 9800-40 Wireless Controller.

Figure 1: Cisco Catalyst 9800-40 Wireless Controller Front View

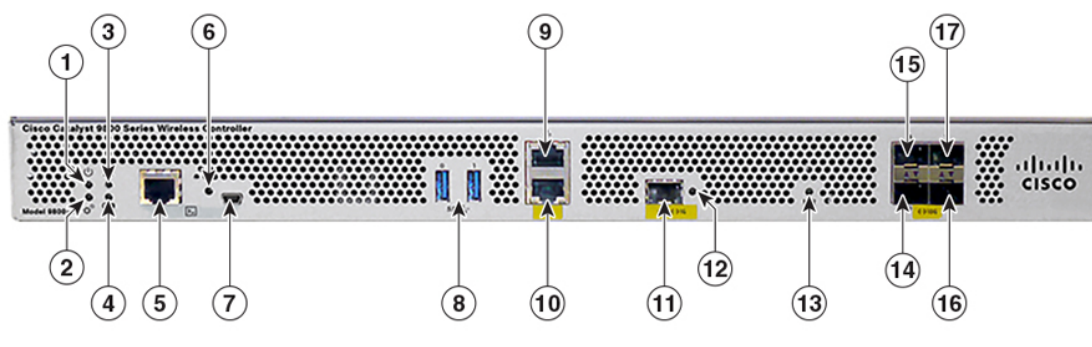

1	PWR—Power LED	11	RP—1-GE SFP port
2	SYS—System LED	12	LINK—RJ-45 connector LED
3	ALM—Alarm LED	13	SSD—SSD activity LED
4	HA—High-Availability LED	14	TE0—1-GE SFP/ 10-GE SFP+ Port 0
5	RJ-45 compatible console port	15	TE1—1-GE SFP/ 10-GE SFP+ Port 1
6	EN—USB console-enabled LED	16	TE2—1-GE SFP/ 10-GE SFP+ Port 2
7	Mini USB console port	17	TE3—1-GE SFP/ 10-GE SFP+ Port 3
8	USB ports 0 and 1		
9	SP—RJ-45 10/100/1000 management Ethernet port		
10	RP—RJ-45 10/100/1000 redundancy Ethernet port		



Note For the Cisco Catalyst 9800-40 Wireless Controller, the power supplies (PEM 0 and PEM1), are located in the rear of the chassis. See the **Rear View** section.

Built-In SFP and SFP+ Ports

The following figure shows the port numbering for the built-in ports.

Figure 2: Cisco Catalyst 9800-40 Wireless Controller Port Numbering

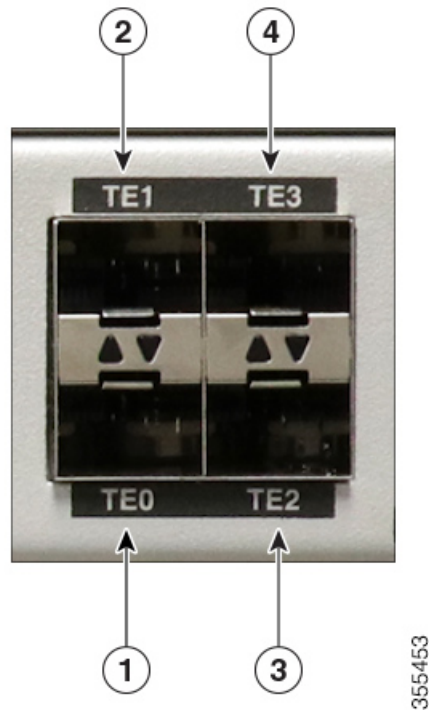

1	TE0—10GE SFP+ transceiver
2	TE1—10GE SFP+ transceiver
3	TE2—10GE SFP+ transceiver
4	TE3—10GE SFP+ transceiver



Note By default, the interfaces from 0 - 3 in the Cisco Catalyst 9800-40 Wireless Controller are enabled.

The port LEDs behave as follows:

- Off—Indicates the port is not enabled by software.
- Amber—Indicates the port is enabled by software but there is a problem with the link.
- Green—Indicates the port is enabled by software and there is valid link.

Management and Storage Connections

The following figure shows the management and storage connections for the Cisco Catalyst 9800-40 Wireless Controller:

Figure 3: Management and Storage Connections for the Cisco Catalyst 9800-40 Wireless Controller

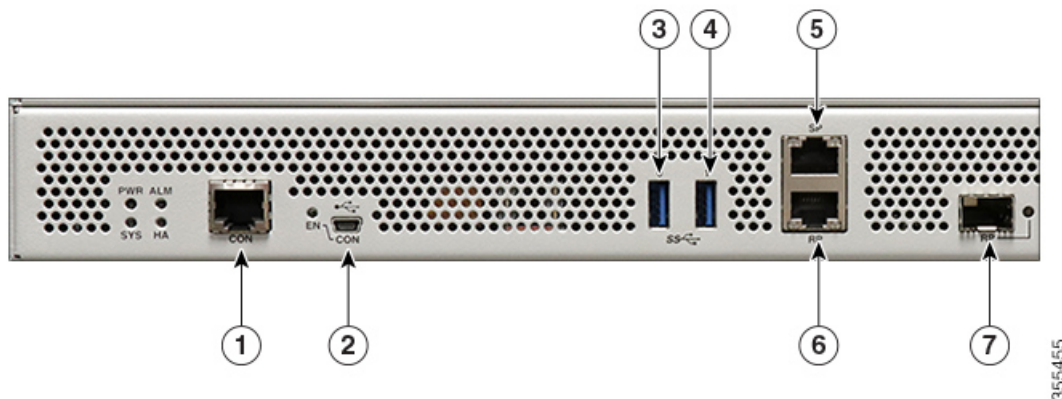









1	CON—RJ-45 compatible console port	5	SP—RJ-45 10/100/1000 management Ethernet port
2	CON—Mini USB connector console port	6	RP—RJ-45 10/100/1000 redundancy Ethernet port
3	USB port 0	7	RP—1-GE SFP+ port
4	USB port 1		











LEDs

The following figure shows the LEDs on the front panel of the Cisco Catalyst 9800-40 Wireless Controller:

Figure 4: Cisco Catalyst 9800-40 Wireless Controller LEDs



No.	LED Label	Description	LED Color	Behavior
1	PWR	Power	Green 	If all the power rails are based on the specification.
2	SYS	System	On 	Remains ON during IOS boot complete.
			Blinking Green 	Remains blinking when IOS booting is in progress.
			Amber 	Remains ON during system crash.
			Blinking Amber 	Remains blinking during secure boot failure.
			Off	Remains OFF during ROMMON boot.
3	ALM	Alarm	Green 	Remains ON during ROMMON boot complete.
			Blinking Green 	Remains blinking when system upgrade is in progress.
			Amber 	Remains ON during ROMMON and SYSTEM boot ups.
			Blinking Amber 	Remains blinking during temperature error and secure boot failure.
			Red	Indicates that the system detects critical warnings. Note The show facility-alarm status command denotes system alarms.
			Off	Remains OFF during IOS boot. Normal Operation

No.	LED Label	Description	LED Color	Behavior
4	HA	High Availability	Green 	Remains ON when HA is active.
			Blinking Green 	Remains blinking when HA Standby Hot.
			Amber 	Blinks slowly when booted or HA Standby Cold.
			Blinks Fast 	Blinks fast during HA maintenance.
5	EN	USB console enabled	Green 	Indicates that the mini USB connector is used as the console.
6	LINK	Management	Solid Green 	Indicates that the RJ-45 connector is not used as the console.
			Flash Green 	Indicates that the RJ-45 connector is being used as the console.
		Built-in EPA (1 SFP + Port Status of 4 LEDs with 1 per SFP)	Off	No link.
		Built-in EPA (1 SFP + Port Status of 4 LEDs with 1 per SFP)	Off	Indicates that the port is not enabled.
			Amber 	Port enabled with a problem in the Ethernet link.
			Green 	Port enabled with a valid Ethernet link.
7	SSD	SSD Activity	Green 	Remains ON during the SSD activity.

Rear View

The following figure shows the rear of the Cisco Catalyst 9800-40 Wireless Controller:

Figure 5: Cisco Catalyst 9800-40 Wireless Controller Rear View

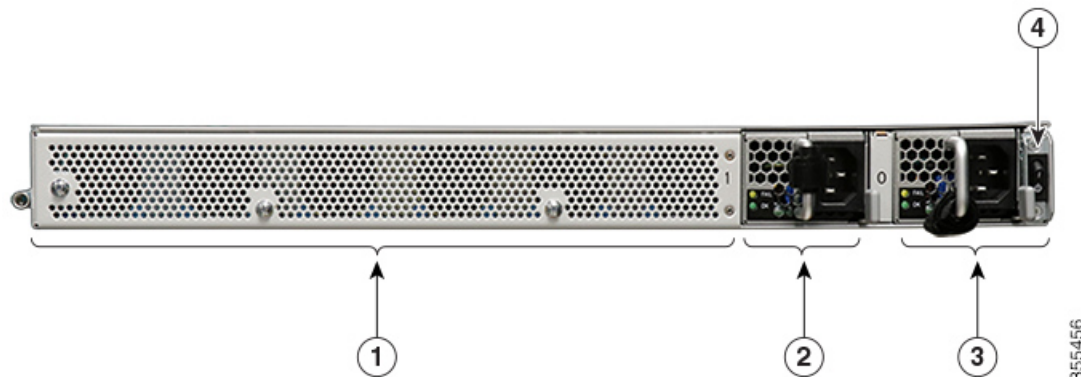

1	Fans	3	Power supply (PEM 0)
2	Power supply (PEM 1)	4	Power/standby switch

The chassis has a front-to-rear airflow. Six internal fans draw cooling air into the chassis and across internal components to maintain an acceptable operating temperature. The fans are numbered from 0 to 5, right to left.

Two power supplies (AC) are accessed from the rear of the controller and are hot-swappable.



Caution The Cisco Catalyst 9800-40 Wireless Controller can support two AC power supplies.

Cisco Product Identification Standard

This section describes the Cisco products and services product identification standard. This feature provides you with the ability to effectively integrate and manage Cisco products in your network and business operations.

Unique Device Identifier

The Unique Device Identifier (UDI) is the Cisco product identification standard for hardware products. A product identification standard removes barriers to enterprise automation and can help you reduce operating expenses.

The UDI provides a consistent electronic, physical, and associated business-to-business information product identification standard.

The UDI is a combination of five data elements. The following table lists the UDI elements:

Table 1: UDI Elements

UDI Data Element	Electronic Visibility	Physical Visibility	Description
PID	Yes	Yes	Product ID, also known as product name, model name, product number

UDI Data Element	Electronic Visibility	Physical Visibility	Description
VID	Yes	Yes	Version ID
SN	Yes	Yes	Serial number, the unique instance of the PID
Entity Name	Yes	—	Type, such as chassis, slot, or power supply
Product Description	Yes	—	Additional product information

The combination of serial number and product ID (PID) is unique and consistent across all Cisco products. The PID that is coded on hardware is called a base product identifier.

Additional orderable PIDs can be associated to a base PID. For instance, an orderable PID may describe a packaging configuration for a product or a bundled group of products sold, tested, and shipped together. Specific unique device identifier (UDI) benefits include the following:

- Identifies:
 - Individual Cisco products in your networks
 - PIDs and serial numbers for service and replaceable products
 - Version IDs (VIDs) for product version visibility
- Facilitates discovery of products subject to recall or upgrade
- Enhances inventory automation of Cisco products

The Cisco product identification standard provides the following features:

show diag chassis eeprom Command

The **show diag chassis eeprom** command displays the PID, VID, PCB serial number, hardware revision, and other such information.

The following is sample output from the show diag chassis eeprom command:

```
WLC# show diag chassis eeprom
MIDPLANE EEPROM data:
Product Identifier (PID) : C9800-40-K9
Version Identifier (VID) : V01
PCB Serial Number : xxxxxxxxxxxx Top Assy. Part Number : xx-xxxx-xx Hardware Revision : 0.1
Asset ID :
CLEI Code : XXXXXXXXXXXX
```



Note Common Language Equipment Identification (CLEI) code is a ten-digit character code that identifies a specific product. A CLEI code is applied to each part within a Cisco Catalyst 9800-40 Wireless Controller as they are programmed in manufacturing for shipment to customers.

show license udi Command

The **show license udi** command displays UDI information.

The following is sample output from the **show license udi** command:

```
WLC# show license udi
SlotID      PID              SN              UDI
-----
*           C9800-40-K9     xxxxxxxxxxxx    C9800-40-K9:xxxxxxxxxx
```



Note For complete information on the product identification standard, see <https://www.cisco.com/c/en/us/products/unique-device-identifier-udi.html>.

Serial Number and PID/VID Label Location

The following figures show the location of the serial number and the PID/VID label on the Cisco Catalyst 9800-40 Wireless Controller:

Figure 6: Cisco Catalyst 9800-40 Wireless Controller Serial Number and PID/VID Label Location

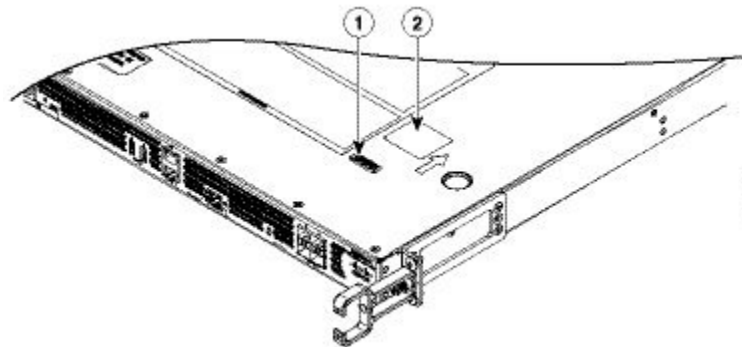

1	Serial Number	2	PID/VID Label
---	---------------	---	---------------

