



Cisco UCS 6300 Series Fabric Interconnect Hardware Installation Guide

First Published: 2016-01-28

Last Modified: 2018-03-19

Americas Headquarters

Cisco Systems, Inc.
170 West Tasman Drive
San Jose, CA 95134-1706
USA
<http://www.cisco.com>
Tel: 408 526-4000
800 553-NETS (6387)
Fax: 408 527-0883

THE SPECIFICATIONS AND INFORMATION REGARDING THE PRODUCTS IN THIS MANUAL ARE SUBJECT TO CHANGE WITHOUT NOTICE. ALL STATEMENTS, INFORMATION, AND RECOMMENDATIONS IN THIS MANUAL ARE BELIEVED TO BE ACCURATE BUT ARE PRESENTED WITHOUT WARRANTY OF ANY KIND, EXPRESS OR IMPLIED. USERS MUST TAKE FULL RESPONSIBILITY FOR THEIR APPLICATION OF ANY PRODUCTS.

THE SOFTWARE LICENSE AND LIMITED WARRANTY FOR THE ACCOMPANYING PRODUCT ARE SET FORTH IN THE INFORMATION PACKET THAT SHIPPED WITH THE PRODUCT AND ARE INCORPORATED HEREIN BY THIS REFERENCE. IF YOU ARE UNABLE TO LOCATE THE SOFTWARE LICENSE OR LIMITED WARRANTY, CONTACT YOUR CISCO REPRESENTATIVE FOR A COPY.

The following information is for FCC compliance of Class A devices: This equipment has been tested and found to comply with the limits for a Class A digital device, pursuant to part 15 of the FCC rules. These limits are designed to provide reasonable protection against harmful interference when the equipment is operated in a commercial environment. This equipment generates, uses, and can radiate radio-frequency energy and, if not installed and used in accordance with the instruction manual, may cause harmful interference to radio communications. Operation of this equipment in a residential area is likely to cause harmful interference, in which case users will be required to correct the interference at their own expense.

The following information is for FCC compliance of Class B devices: This equipment has been tested and found to comply with the limits for a Class B digital device, pursuant to part 15 of the FCC rules. These limits are designed to provide reasonable protection against harmful interference in a residential installation. This equipment generates, uses and can radiate radio frequency energy and, if not installed and used in accordance with the instructions, may cause harmful interference to radio communications. However, there is no guarantee that interference will not occur in a particular installation. If the equipment causes interference to radio or television reception, which can be determined by turning the equipment off and on, users are encouraged to try to correct the interference by using one or more of the following measures:

- Reorient or relocate the receiving antenna.
- Increase the separation between the equipment and receiver.
- Connect the equipment into an outlet on a circuit different from that to which the receiver is connected.
- Consult the dealer or an experienced radio/TV technician for help.

Modifications to this product not authorized by Cisco could void the FCC approval and negate your authority to operate the product

The Cisco implementation of TCP header compression is an adaptation of a program developed by the University of California, Berkeley (UCB) as part of UCB's public domain version of the UNIX operating system. All rights reserved. Copyright © 1981, Regents of the University of California.

NOTWITHSTANDING ANY OTHER WARRANTY HEREIN, ALL DOCUMENT FILES AND SOFTWARE OF THESE SUPPLIERS ARE PROVIDED "AS IS" WITH ALL FAULTS. CISCO AND THE ABOVE-NAMED SUPPLIERS DISCLAIM ALL WARRANTIES, EXPRESSED OR IMPLIED, INCLUDING, WITHOUT LIMITATION, THOSE OF MERCHANTABILITY, FITNESS FOR A PARTICULAR PURPOSE AND NONINFRINGEMENT OR ARISING FROM A COURSE OF DEALING, USAGE, OR TRADE PRACTICE.

IN NO EVENT SHALL CISCO OR ITS SUPPLIERS BE LIABLE FOR ANY INDIRECT, SPECIAL, CONSEQUENTIAL, OR INCIDENTAL DAMAGES, INCLUDING, WITHOUT LIMITATION, LOST PROFITS OR LOSS OR DAMAGE TO DATA ARISING OUT OF THE USE OR INABILITY TO USE THIS MANUAL, EVEN IF CISCO OR ITS SUPPLIERS HAVE BEEN ADVISED OF THE POSSIBILITY OF SUCH DAMAGES.

Any Internet Protocol (IP) addresses and phone numbers used in this document are not intended to be actual addresses and phone numbers. Any examples, command display output, network topology diagrams, and other figures included in the document are shown for illustrative purposes only. Any use of actual IP addresses or phone numbers in illustrative content is unintentional and coincidental.

Cisco and the Cisco logo are trademarks or registered trademarks of Cisco and/or its affiliates in the U.S. and other countries. To view a list of Cisco trademarks, go to this URL: [www.cisco.com go trademarks](http://www.cisco.com/go/trademarks). Third-party trademarks mentioned are the property of their respective owners. The use of the word partner does not imply a partnership relationship between Cisco and any other company. (1721R)

© 2016–2016 Cisco Systems, Inc. All rights reserved.



CHAPTER 1

Product Overview

- [Fabric Interconnect Features, on page 1](#)
- [Cisco UCS 6332 Fabric Interconnect , on page 2](#)
- [Cisco UCS 6332-16UP Fabric Interconnect, on page 3](#)
- [Ports on the Cisco UCS 6300 Fabric Interconnects, on page 3](#)
- [Port Numbering, on page 5](#)
- [Port Breakout Feature, on page 6](#)
- [Power Supplies, on page 6](#)
- [Fan Modules, on page 8](#)
- [LED Descriptions, on page 8](#)
- [Supported Transceivers, on page 12](#)

Fabric Interconnect Features

A Cisco UCS 6300 Series Fabric Interconnect provides both network connectivity and management capabilities to a Cisco UCS system. The fabric interconnect provides Ethernet and Fibre Channel to the servers in the system, the servers connect to the fabric interconnect, and the fabric interconnect connects to the LAN or SAN.

Each Cisco UCS 6300 Series Fabric Interconnect runs Cisco UCS Manager to fully manage all Cisco UCS elements. The fabric interconnect supports full end-to-end 40-Gigabit capabilities in the fabric and enables 16-Gigabit Fibre Channel capabilities. High availability can be achieved when a Cisco UCS 6300 Series Fabric Interconnect is connected to another Cisco UCS 6300 Series Fabric Interconnect through the L1 or L2 port on each device.

The Cisco UCS 6300 Series Fabric Interconnect joins next-generation UCS products, including the following hardware:

- Cisco UCS 6332 Fabric Interconnect, an Ethernet or Fibre Channel over Ethernet (FCoE) chassis with 32 40-Gigabit QSFP+ ports
- Cisco UCS 6332-16UP Fabric Interconnect, an Ethernet, FCoE, and Fibre Channel chassis with 16 1- or 10-Gigabit SFP+ ports or 16 4-, 8-, or 16-Gigabit Fibre Channel ports, 24 40-Gigabit QSFP+ ports
- Cisco 2304 IOM, an I/O module with 8 40-Gigabit backplane ports and 4 40-Gigabit uplink ports
- Multiple VICs

Cisco UCS 6332 Fabric Interconnect

The Cisco UCS 6332 Fabric Interconnect is a 1 RU, top-of-rack switch with 32 40-Gigabit QSFP+ ports, one 100/1000 network management port, one RS-232 console port for setting the initial configuration, and two USB ports for saving or loading configurations. The switch also includes an L1 port and an L2 port for connecting two fabric interconnects to provide high availability. The switch mounts in a standard 19-inch rack, such as the Cisco R Series rack.

Cooling fans pull air front-to-rear. That is, air intake is on the fan side and air exhaust is on the port side.

Figure 1: Cisco UCS 6332 Fabric Interconnect Rear View

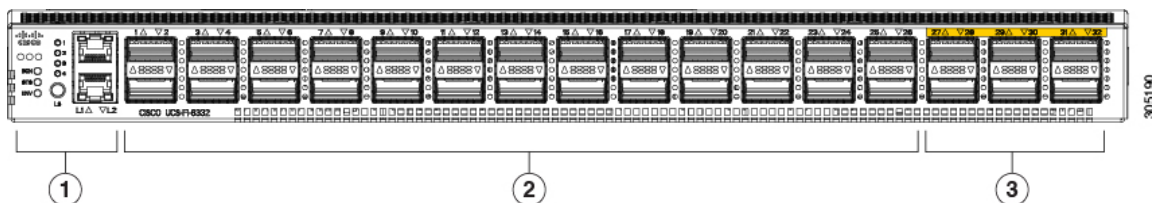

1	Port lane switch button, port lane LEDs, and L1 and L2 ports. For additional information about the port lane switch and LEDs, see Lane Switch and LEDs, on page 8 .	2 Ports 1–12 and ports 15–26 can operate as 40-Gbps QSFP+ ports, or as 4 x 10-Gbps SFP+ breakout ports. Ports 1 - 4 support Quad to SFP or SFP+ (QSA) adapters to provide 1-Gbps/10 Gbps operation. Ports 13 and 14 can operate as 40-Gbps QSFP+ ports. They cannot operate as 4 x 10-Gbps SFP+ breakout ports.
3	Ports 27–32 operate as 40-Gbps QSFP+ ports.	

For additional information about the port groups, see [Port Numbering, on page 5](#).

Figure 2: Cisco UCS 6332 Fabric Interconnect Front View

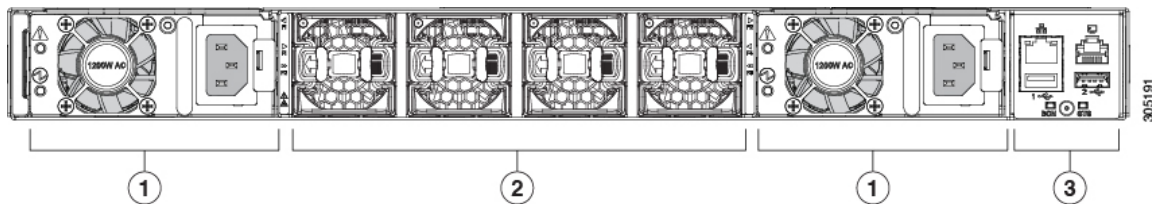

1	Power supply and power cord connector	2 Fans 1 through 4, numbered left to right, when facing the front of the chassis
3	Management, console, and USB ports, and LEDs. For more information about the connections ports and LEDs, see Connection Ports and LEDs, on page 10 .	

Cisco UCS 6332-16UP Fabric Interconnect

The Cisco UCS 6332-16UP Fabric Interconnect is a 1 RU top-of-rack switch with 24 40-Gb QSFP+ ports, 16 10-Gb SFP ports, one 100/1000 network management port, one RS-232 console port for setting the initial configuration, and two USB ports for saving or loading configurations. The switch also includes an L1 port and an L2 port for connecting two fabric interconnects to provide high availability. The switch mounts in a standard 19-inch rack, such as the Cisco R Series rack.

Cooling fans pull air front-to-rear. That is, air intake is on the fan side and air exhaust is on the port side.

Figure 3: Cisco UCS 3223-16UP Fabric Interconnect Rear View

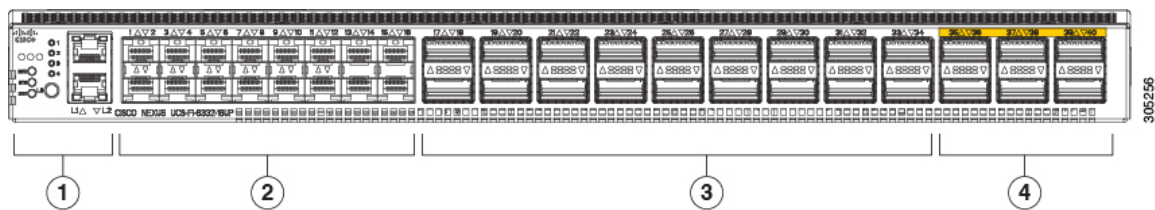

1	Port lane switch button, port lane LEDs, and L1 and L2 ports. For more information about the port lane switch, see Lane Switch and LEDs, on page 8 .	2	Ports 1–16 are Unified Ports (UP) that operate either as 1- or 10-Gbps SFP+ fixed Ethernet ports; or as 4-, 8-, or 16-Gigabit Fibre Channel ports.
3	Ports 17–34 operate either as 40-Gbps QSFP+ ports, breakout mode for 4 x 10-Gigabit SFP+ breakout ports, or QSA for 10G.	4	Ports 35–40 operate as 40-Gbps QSFP+ ports.

Figure 4: Cisco UCS 6332-16UP Fabric Interconnect Front View

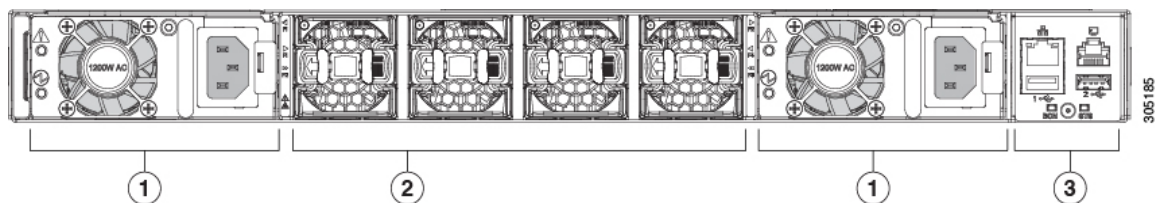

1	Power supply and power cord connector	2	Fans1 through 4, numbered left to right, when facing the front of the chassis
3	Management, console, and USB ports, and LEDs. For more information about the connection ports, see Connection Ports and LEDs, on page 10 .		

Ports on the Cisco UCS 6300 Fabric Interconnects

Ports on the Cisco UCS 6300 Series can be configured to carry either Ethernet or Fibre Channel traffic. These ports are not reserved. They cannot be used by a Cisco UCS domain until you configure them.



Note When you configure a port on a fabric interconnect, the administrative state is automatically set to enabled. If the port is connected to another device, this may cause traffic disruption. You can disable the port after it has been configured.

The following table summarizes the second and third generation ports for the Cisco UCS fabric interconnects.

	Cisco UCS Mini	Second Generation		Third Generation	
Item	Cisco UCS 6324	Cisco UCS 6248 UP	Cisco UCS 6296 UP	Cisco UCS 6332	Cisco UCS 6332-16UP
Description	Fabric Interconnect with 4 ports and 1 scalability port	48-Port Fabric Interconnect	96-Port Fabric Interconnect	32-Port Fabric Interconnect	40-Port Fabric Interconnect
Form factor	1 RU	1 RU	2 RU	1 RU	1 RU
Number of fixed 10 GB Interfaces	4	32	48	96 (24 X 4 using 4 x 10G breakout cables), QSA	88 (18 x 4 using 4 x 10G breakout cables)
Number of 1GB Interfaces (depending on the SFP module installed)	4	32	48	4 (only ports 1 - 4 with QSA adapter)	Ports 1-16
Unified Ports (8-, 4-, 2-, 1-Gbps, FC, FCoE)	4	All	All	None	None
Number of 40-Gbps ports	1	—	—	32	24
Unified Ports (1- or 10 Gbps Ethernet, or 4-, 8-, or 16-Gbps, Fibre Channel)	—	None	None	None	Ports 1-16
Compatibility with the IOM	N/A	UCS 2204, UCS 2208	UCS 2204, UCS 2208	All	All
Expansion Slots	—	1 (16 port)	3 (16 port)	None	None

	Cisco UCS Mini	Second Generation		Third Generation	
Fan Modules	—	2	5	5	4
Power Supplies	—	2 (AC/DC available)	2 (AC/DC available)	2 (AC/DC/HVDC available)	2 (AC/DC/HVDC available)



Note The third-generation ports support breakout capability. For more information on how the 40-Gigabit Ethernet ports can be converted into 4 X 10-Gigabit Ethernet ports, see http://www.cisco.com/c/en/us/td/docs/unified_computing/ucs/ucs-manager/GUI-User-Guides/Getting-Started/3-1/b_UCSM_Getting_Started_Guide_3_1/b_UCSM_Initial_Configuration_Guide_3_0_chapter_011110.html.

Port Numbering

Ports on the Cisco UCS 6332 Fabric Interconnect are numbered and grouped according to their function. The ports are numbered top to bottom and left to right. The following figure shows the port numbering.

Figure 5: Cisco UCS 6332 Fabric Interconnect Port Numbers

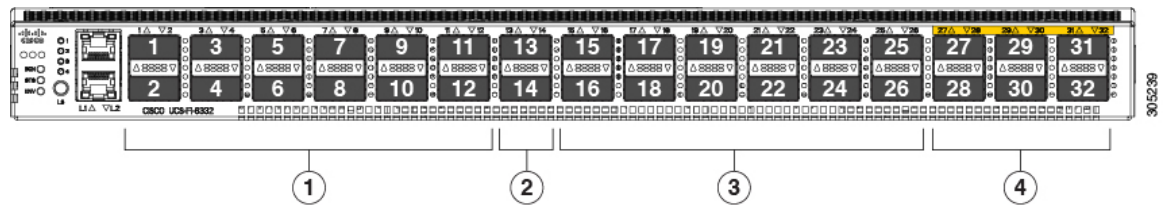

1	Ports 1–12. Each port can operate as either a 40-Gbps QSFP+ port or as 4 x 10-Gbps SFP+ breakout ports. Ports 1 - 4 support Quad to SFP or SFP+ (QSA) adapters to provide 1-Gbps/10-Gbps operation.	2	Ports 13–14. Each port operates as a 40-Gbps QSFP+ port. These two ports cannot operate as 4 x 10-Gbps SFP+ breakout ports.
3	Ports 15–26. Each port can operate as either a 40-Gbps QSFP+ port or as 4 x 10-Gbps SFP+ breakout ports.	4	Ports 28–32. Each port operates as a dedicated 40-Gbps QSFP+ port.

Ports on the Cisco UCS 6332-16UP Fabric Interconnect are numbered and grouped according to their function. The ports are numbered top to bottom and left to right. The following figure shows the port numbering.

Figure 6: Cisco UCS 6332-16UP Fabric Interconnect Port Numbers

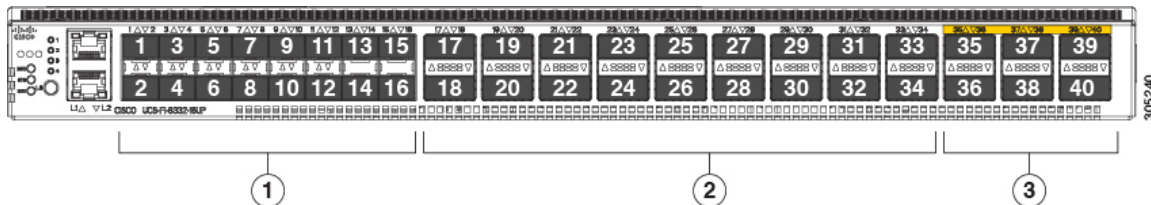

1	Ports 1–16. These ports are universal ports that operate as 1- or 10-Gbps fixed Ethernet or as 4-, 8-, or 16-Gbps Fibre Channel.	2	Ports 17–34. Each port operates as either 40-Gbps QSFP+ port, breakout mode for 4 x 10-Gigabit SFP+ breakout port, or QSA for 10G.
3	Ports 35–40. Each port operates as a fixed 40-Gbps QSFP+ port.	4	—

Port Breakout Feature

Both the Cisco UCS 6332 fabric interconnect and the Cisco UCS 6332-16UP fabric interconnect have ports that can be configured for the breakout feature that supports connectivity between 40-Gigabit Ethernet ports and 10-Gigabit Ethernet ports. This feature provides backward compatibility to existing hardware that supports 10-Gigabit Ethernet. A 40-Gigabit Ethernet port can be used as 4 10-Gigabit Ethernet ports. Using a 40-Gigabit Ethernet SFP, these ports on the UCS 6300 Series fabric interconnect can be configured as an appliance port, server port (IOM, Fabric Extender, or C-series server), uplink, FCoE uplink and/or FCoE storage port.

The breakout feature can be configured on ports 1 to 12 and ports 15 to 26 on the Cisco UCS 6332 fabric interconnect. Ports 17 to 34 on the Cisco UCS 6332-16UP fabric interconnect support the breakout feature. For information on how to configure the breakout feature, see the *Getting Started Guide* for the latest release of Cisco UCS Manager. The configuration guides are available at this URL: <http://www.cisco.com/c/en/us/support/servers-unified-computing/ucs-manager/products-installation-and-configuration-guides-list.html>.



Note Configuring the breakout feature requires a reboot of the fabric interconnect.

Power Supplies

The fabric interconnect has two power supplies that are accessible from the rear of the chassis. Two power supplies can be used for redundancy, but the fabric interconnect is fully functional with one power supply.

Table 1: Power Supply Models

Cisco PID	Fabric Interconnect	Source	Wattage
UCS-PSU-6332-AC	Cisco UCS 6332 and Cisco UCS 6332-16UP	110 to 240 VAC	650 W

Cisco PID	Fabric Interconnect	Source	Wattage
UCS-PSU-6332-DC	Cisco UCS 6332 and Cisco UCS 6332-16UP	-48 VDC	930 W
N9K-PUV-1200W	Cisco UCS 6332 and Cisco UCS 6332-16UP	240 to 380 VDC	1230 W

Figure 7: AC Power Supply for the Cisco UCS 6332 and UCS 6332-16UP Fabric Interconnect

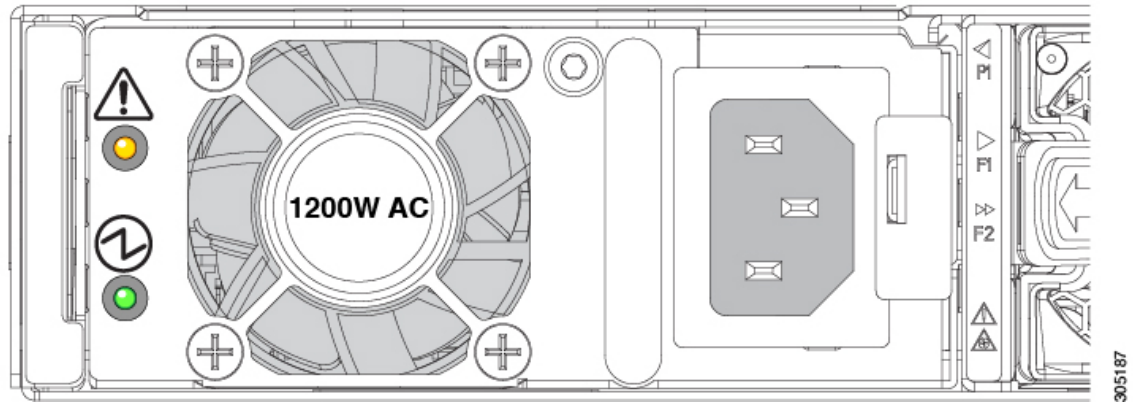

Power supplies have two LEDs: one for power status and one for a failure condition.

1	Amber fault/error LED	2	Green power on LED
---	-----------------------	---	--------------------

LED	State	Description
Power on LED	Solid green	Power supply is on and functioning properly
Power on LED	Blinking green	3.3 V voltage standby (VSB) is on but the power supply is not powering the other units
Power on LED	Off	There is no AC power to the power supply
Fault/error LED	Solid amber	Power supply failure that indicates an over voltage, over current, or over temperature
Fault/error LED	Blinking amber	AC power is present, 3.3 VSB is on, and the power supply is off
Fault/error LED	Off	Normal operation

If one power supply is installed in the chassis, but the other power supply slot is empty, a blank filler panel should be used to cover the empty slot.

Fan Modules

LED Descriptions

The fabric interconnect has status LEDs and QSFP+ port LEDs .

Table 2: Status LEDs for the Cisco UCS 6300 Series Fabric Interconnect

LED	Color	Location
Ports	Green and Yellow	Front and rear of chassis
Beacon	Blue	Front and rear of chassis
System Status	Green, Amber, or Red	Front and rear of chassis
Environment	Amber or Red	Rear of chassis
Power supply	Green or Amber	Front of chassis
Fan modules	Green or Amber	Front of chassis, integrated in the fan

QSFP+ port LEDs on the front of the chassis allow you to see the link status of the ports. When you press the push button on the front panel, a QSFP+ port LED shows the link and activity status for the selected lane, and one of the four green LEDs show which lane is selected. You can press the push button four times to check all four lanes of each QSFP+ port. After the fourth press, all LEDs turn off, indicating that the current link status is 40-Gbps mode, which is the default mode.

Lane Switch and LEDs

Both the Cisco UCS 6332 Fabric Interconnect and the UCS 6332-16UP Fabric Interconnect have a lane switch button and lane LEDs that are shown in the following figure:

Figure 8: Port Lane Switch, HA Ports, and LEDs

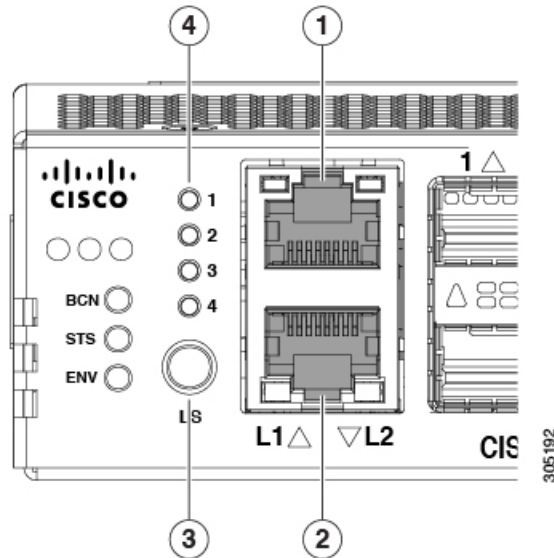

1	L1 highly available port	2	L2 highly available port
3	Lane switch	4	QSFP+ lane LEDs

The port lane switch operates as follows:

- The default mode of operation after bootup is 40-Gbps. The LED on each individual port QSFP+ port indicates the 40-Gbps link status. The lane switch button is illuminated, but none of the four lane LEDs are illuminated.
- Pressing the lane switch button for the first time causes the lane 1 LED to illuminate. The LED on each individual QSFP+ port represents the lane 1 status of the port.
- Pressing the lane switch button for the second time causes the lane 2 LED to illuminate. The LED on each individual QSFP+ port represents the lane 2 status of the port.
- Pressing the lane switch button for the third time causes the lane 3 LED to illuminate. The LED on each individual QSFP+ port represents the lane 3 status of the port.
- Pressing the lane switch button for the fourth time causes the lane 4 LED to illuminate. The LED on each individual QSFP+ port represents the lane 4 status of the port.
- Pressing the lane switch button again causes the 40-Gbps mode to be in effect again.

When you cycle the lane switch button, the LED of a QSFP+ port indicates the status of the different lanes. If a port is configured in breakout mode, the LED for a QSFP+ port is off when the lane LEDs are off. If a 40-Gbps port is not operating in breakout mode, and if the link is up, the LED on a QSFP+ port is green when all the lane LEDs are off. The LED turns off when you press the lane button to lane 1, 2, 3, or 4.

The QSFP+ port LEDs for ports 13 and 14 are always the same as the 40-Gbps mode status because those two ports cannot operate in breakout mode.

Connection Ports and LEDs

Both the Cisco UCS 6332 Fabric Interconnect and the UCS 6332-16UP Fabric Interconnect have the connection ports and LEDs shown in the following figure:

Figure 9: Connection Ports and LEDs

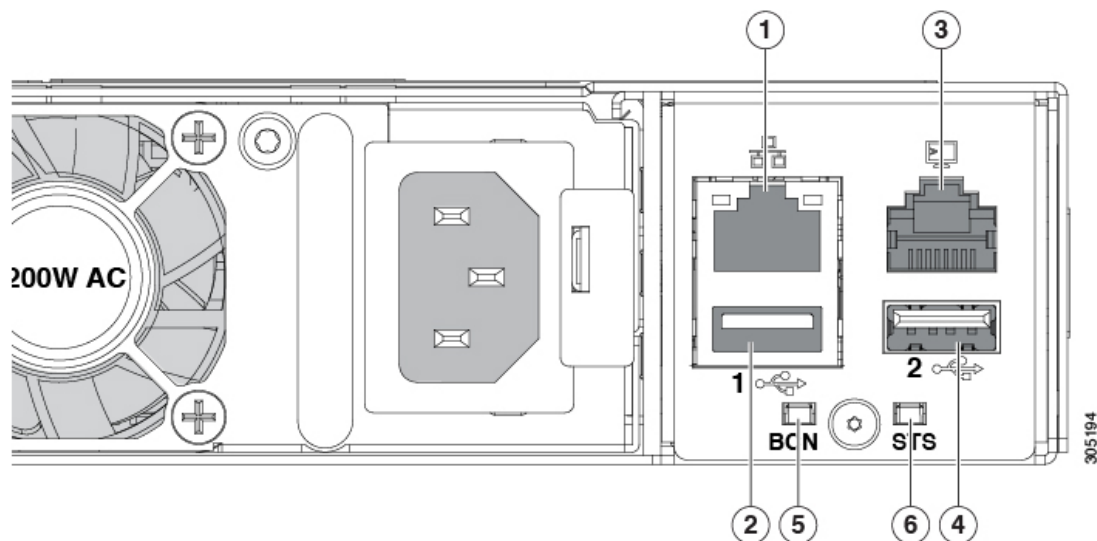

1	RJ45 network management port	2	USB port 1
3	RJ45 console port	4	USB port 2
5	Beaming LED and button	6	System status LED

The status of the beacon and system LEDs are as follows:

LED	Location	Function	Color	State	Description
Beacon LED	Front and rear	Indicate selected chassis	Blue	Solid on	Chassis selected
Beacon LED	Front and rear	Indicate selected chassis	Blue	Off	Chassis not selected
System status LED	Front and rear	Indicate system power/health at bootup and run time	Green	Solid on	Normal operation
System status LED	Front and rear	Indicate system power/health at bootup and run time	Green	Off	System powered off
System status LED	Front and rear	Indicate system power/health at bootup and run time	Amber	On	System fault

LED	Location	Function	Color	State	Description
System status LED	Front and rear	Indicate system power/health at bootup and run time	Red	Solid on	Power shut down by software
System status LED	Front and rear	Indicate system power/health at bootup and run time	Red	Blinking	Secure boot validation has failed

Management Port LEDs

The status of the management ports is listed below.

LED Position	LED State	Description
Left	Off	No link
Left	Solid green	Physical link
Right	Off	No activity
Right	Blinking green	Activity

System Environment LEDs

The system environment LED states are listed below.

LED State	Description
Solid amber	Minor fan alarm (a fan is missing or there is a failure)
Solid red	Major fan alarm (two or more fans are missing or have failed, or there is a fan direction mismatch)

QSFP Port LEDs

The QSFP port LED states are listed below.

LED State	Description
Yellow	Enabled, but SFP not inserted
Green	Enabled and link is up
Off	Enabled, but link is not connected
Blinking yellow	Power On Self Test (POST) failed
Blinking yellow	Port beacon enabled

LED State	Description
Yellow	Administrative (software shutdown)

L1 and L2 Port LEDs

The L1 and L2 port LED states are listed below.

LED Position	LED State	Description
Left	Off	No link
Left	Solid green	Physical link
Right	Off	No activity
Right	Blinking green	Activity

Supported Transceivers

The Cisco UCS 6300 Series Fabric Interconnects support SFP+ Ethernet transceivers, SFP transceivers, SFP+ transceivers, SFP+ copper twinax cables with integrated transceivers, SFP Fibre Channel transceivers, QSFP transceivers, and QSFP cables. Except where noted, both the UCS 6332 Fabric Interconnect and the UCS 6332-16UP Fabric Interconnect support all the transceivers listed in this section.

On the Cisco UCS 6332 Fabric Interconnect, all 1-Gigabit and 10-Gigabit transceivers and twinax cables must use a QSA module (CVR-QSFP-SFP10G) to operate in a 40-Gbps QSFP+ port. In addition, the QSA module is required for a 40-Gbps QSFP+ port to operate at 1 Gbps or 10 Gbps.

On the Cisco UCS 6332-16UP Fabric Interconnect, all 1-Gigabit and 10-Gigabit transceivers, Fibre Channel transceivers, and twinax cables must use a QSA module (CVR-QSFP-SFP10G) to operate in ports 17–40 (the 40-Gbps QSFP+ ports). Ports 1–16 operate as SFP+ universal ports that are capable of operating at 1- or 10-Gbps fixed Ethernet or 4-, 8-, or 16-Gbps Fibre Channel ports and do not need a QSFP to SFP+ adapter. In addition, the QSA module is required for a 40-Gbps QSFP+ port to operate at 1 Gbps or 10 Gbps.

SFP 1-Gigabit Transceivers

The SFP 1-Gigabit Ethernet transceiver module is a bidirectional device with a transmitter and receiver in the same physical package.

Table 3: Supported SFP Optical Transceivers

Model	Description
GLC-T	1000BASE-T standard
GLC-SX-MMD	1000BASE-SX short wavelength; with MDOM
SFP-GE-T	1000BASE-T SFP (NEBS 3 ESD)—supported only on the UCS 6332-16UP Fabric Interconnect



Note The maximum length of fiber optic runs is limited to 300 meters. This is imposed by our use of 802.3X/802.1Qbb Priority Pauses. SFP-10G-LR is supported between fabric interconnect and I/O Module, but the 300 m limit still applies.

SFP+ Transceivers and SFP+ Copper Cables

The enhanced SFP+ 10-Gigabit Ethernet transceiver module is a bidirectional device with a transmitter and receiver in the same physical package. It has a 20-pin connector on the electrical interface and duplex LC connector on the optical interface.

Table 4: Supported Transceivers

Product ID	Description
SFP-10G-SR	10GBASE-SR SFP+ module (multimode fiber [MMF])
SFP-10G-SR -S	10GBASE-SR SFP+ module (multimode fiber [MMF], S-Class)
SFP-10G-LR	10GBASE-LR SFP+ module (single-mode fiber [SMF])
SFP-10G-LR -S	10GBASE-LR SFP+ module (single-mode fiber [SMF], S-Class)
FET-10G	Cisco 10G Line Extender for FEX
SFP+ Copper Cables with Integrated Transceivers	
SFP-H10GB-CU1M	10GBASE-CU SFP+ cable 1 meter, passive
SFP-H10GB-CU2M	10GBASE-CU SFP+ cable 2 meter, passive
SFP-H10GB-CU3M	10GBASE-CU SFP+ cable 3 meter, passive
SFP-H10GB-CU5M	10GBASE-CU SFP+ cable 5 meter, passive
SFP-H10GB-ACU7M	10GBASE-CU SFP+ cable 7 meter, active
SFP-H10GB-ACU10M	10GBASE-CU SFP+ cable 10 meter, active
SFP-10G-AOC1M	10GBASE-AOC SFP+ cable 1 meter
SFP-10G-AOC2M	10GBASE-AOC SFP+ cable 2 meter
SFP-10G-AOC3M	10GBASE-AOC SFP+ cable 3 meter
SFP-10G-AOC5M	10GBASE-AOC SFP+ cable 5 meter
SFP-10G-AOC7M	10GBASE-AOC SFP+ cable 7 meter

Product ID	Description
SFP-10G-AOC10M	10GBASE-AOC SFP+ cable 10 meter



Note The maximum length of fiber optic runs is limited to 300 meters. This is imposed by our use of 802.3X/802.1Qbb Priority Pauses. SFP-10G-LR is supported between fabric interconnect and FEX, but the 300 m limit still applies.

QSFP Transceivers and Cables

The Cisco UCS 6300 Series Fabric Interconnects support Cisco 40GGBASE Quad Small Form Factor (QSFP) transceiver modules.

Table 5: Supported QSFP Transceivers and Cables

Model	Description
QSFP-40G-SR4	40GBASE-SR4 QSFP module (multimode fiber [MMF]), 100 meter
QSFP-40G-SR4-S	40GBASE-SR4 QSFP module (multimode fiber [MMF]), 100 meter
QSFP-40G-CSR4	40GBASE Extended CSR4 QSFP module (MMF), 300 meter
QSFP-40G-LR4	Cisco 40GBASE-LR4 QSFP+ transceiver module for SMF, duplex LC connector
QSFP-40G-LR4-S	Cisco 40GBASE-LR4 QSFP+ transceiver module for SMF, duplex LC connector
QSFP-40G-SR-BD	Cisco QSFP40G BiDi Short-reach transceiver
FET-40G	Cisco 40G Line Extender for FEX
QSFP-4x10G-AC7M	Cisco 40GBASE-CR4 QSFP+ to 4 10GBASE-CU SFP+ active direct-attached breakout cable, 7 meter
QSFP-4x10G-AC10M	Cisco 40GBASE-CR4 QSFP+ to 4 10GBASE-CU SFP+ active direct-attached breakout cable, 10 meter
QSFP-H40G-CU1M	Cisco 40GBASE-CR4 SFP+ passive direct-attach copper cable, 1 meter
QSFP-H40G-CU3M	Cisco 40GBASE-CR4 SFP+ passive direct-attach copper cable, 3 meter
QSFP-H40G-CU5M	Cisco 40GBASE-CR4 SFP+ passive direct-attach copper cable, 5 meter
QSFP-H40G-ACU7M	Cisco 40GBASE-CR4 SFP+ active direct-attach copper cable, 7 meter
QSFP-H40G-ACU10M	Cisco 40GBASE-CR4 SFP+ active direct-attach copper cable, 10 meter
QSFP-4SFP10G-CU1M	Cisco 40GBASE-CR4 QSFP+ to 4 10GBASE-CU SFP+ passive direct-attach copper transceiver assembly, 1 meter

QSFP-4SFP10G-CU3M	Cisco 40GBASE-CR4 QSFP+ to 4 10GBASE-CU SFP+ passive direct-attach copper transceiver assembly, 13 meter
QSFP-4SFP10G-CU5M	Cisco 40GBASE-CR4 QSFP+ to 4 10GBASE-CU SFP+ passive direct-attach copper transceiver assembly, 5 meter
QSFP-4X10G-AOC1M	Cisco 40GBASE-AOC QSFP TO 4 SFP+ Active Optical breakout Cable, 1 meter
QSFP-4X10G-AOC2M	Cisco 40GBASE-AOC QSFP TO 4 SFP+ Active Optical breakout Cable, 2 meter
QSFP-4X10G-AOC3M	Cisco 40GBASE-AOC QSFP TO 4 SFP+ Active Optical breakout Cable, 3 meter
QSFP-4X10G-AOC5M	Cisco 40GBASE-AOC QSFP TO 4 SFP+ Active Optical breakout Cable, 5 meter
QSFP-4X10G-AOC7M	Cisco 40GBASE-AOC QSFP TO 4 SFP+ Active Optical breakout Cable, 7 meter
QSFP-4X10G-AOC10M	Cisco 40GBASE-AOC QSFP TO 4 SFP+ Active Optical breakout Cable, 10 meter
QSFP-H40G-AOC1M	Cisco 40GBASE-AOC QSFP direct-attach Active Optical Cable, 1 meter
QSFP-H40G-AOC2M	Cisco 40GBASE-AOC QSFP direct-attach Active Optical Cable, 2 meter
QSFP-H40G-AOC3M	Cisco 40GBASE-AOC QSFP direct-attach Active Optical Cable, 3 meter
QSFP-H40G-AOC5M	Cisco 40GBASE-AOC QSFP direct-attach Active Optical Cable, 5 meter
QSFP-H40G-AOC7M	Cisco 40GBASE-AOC QSFP direct-attach Active Optical Cable, 7 meter
QSFP-H40G-AOC10M	Cisco 40GBASE-AOC QSFP direct-attach Active Optical Cable, 10 meter
QSFP-H40G-AOC15M	Cisco 40GBASE-AOC QSFP direct-attach Active Optical Cable, 15 meter
CVR-QSFP-SFP10G	Cisco 40GBASE QSFP to SFP+ and SFP adapter



Note The Cisco UCS 6332 Fabric Interconnect does not support passive copper CR4 cables in ports 27 through 32 because these ports do not support **negotiate auto**. All other 40-Gigabit ports on the Cisco UCS 6332 Fabric Interconnect support passive copper CR4 cables.

The Cisco UCS 6332-16UP Fabric Interconnect does not support passive copper CR4 cables in ports 35 through 40 because these ports do not support **negotiate auto**. All other 40-Gigabit ports on the Cisco UCS 6332-16UP Fabric Interconnect support passive copper CR4 cables.

SFP Fibre Channel Transceivers

The Cisco UCS 6332-16UP Fabric Interconnect supports the SFP Fibre Channel transceivers listed below. These transceivers are not supported on the UCS 6332 Fabric Interconnect.

Table 6: SFP Fiber Channel Transceivers

Model	Description
DS-SFP-FC4G-SW	4 Gbps Fibre Channel-SW SFP, LC
DS-SFP-FC8G-SW	8-Gbps Fibre Channel SW SFP+, LC
DS-SFP-FC8G-LW	8-Gbps Fibre Channel LW SFP+, LC
DS-SFP-FC16G-SW	16-Gbps Fibre Channel SW SFP+, LC



Note The maximum length of fiber optic runs from the fabric interconnect to a chassis is limited to 300 meters. This restriction is imposed by the use of 802.3X/802.1Qbb Priority Pauses.



CHAPTER 2

Installing the Cisco UCS 6300 Series Fabric Interconnect

- [Preparing for Installation, on page 17](#)
- [Cabinet and Rack Requirements, on page 20](#)
- [Cable Management Guidelines, on page 22](#)
- [Required Equipment, on page 22](#)
- [Unpacking and Inspecting the Cisco UCS Fabric Interconnect, on page 22](#)
- [Installing the Cisco UCS Chassis or UCS Chassis in a Cabinet or Rack, on page 23](#)
- [Grounding the System, on page 27](#)
- [Starting the System, on page 32](#)
- [Replacing or Installing Components, on page 34](#)
- [Repacking the Cisco UCS Fabric Interconnect for Return Shipment, on page 43](#)

Preparing for Installation

Considerations and Warnings



Note Before you install, operate, or service the system, read the [Regulatory Compliance and Safety Information for Cisco UCS](#) for important safety information.



Warning **IMPORTANT SAFETY INSTRUCTIONS** This warning symbol means danger. You are in a situation that could cause bodily injury. Before you work on any equipment, be aware of the hazards involved with electrical circuitry and be familiar with standard practices for preventing accidents. Use the statement number provided at the end of each warning to locate its translation in the translated safety warnings that accompanied this device. Statement 1071

SAVE THESE INSTRUCTIONS

**Warning**

This unit is intended for installation in restricted access areas. A restricted access area can be accessed only through the use of a special tool, lock and key, or other means of security. Statement 1017

**Warning**

Only trained and qualified personnel must be allowed to install, replace, or service this equipment. Statement 1030

**Note**

Each new fabric interconnect requires a license. For information on licensing, see the *Configuration Guide* for the version of Cisco UCS Manager that you are using. The configuration guides are available at the following URL:

http://www.cisco.com/en/US/products/ps10281/products_installation_and_configuration_guides_list.html

Installation Options

You can install the Cisco UCS Fabric Interconnect chassis in a perforated or solid-walled EIA cabinet or an open EIA rack (the Cisco R Series Rack is an ideal choice), using the rack-mount kit shipped with the chassis. For instructions on installing the chassis using the rack-mount kit shipped with the chassis, see [Installing the Cisco UCS Chassis or UCS Chassis in a Cabinet or Rack, on page 23](#).

Airflow Considerations

The FI's cooling fans pull air front-to-rear. That is, air intake is on the fan side and air exhaust is on the port side.

To ensure proper airflow, follow these guidelines:

- Maintain ambient airflow throughout the data center to ensure normal operation.
- Consider the heat dissipation of all equipment when determining air conditioning requirements. When evaluating airflow requirements, take into consideration that hot air generated by equipment at the bottom of the rack can be drawn in the intake ports of the equipment above.
- Ensure that exhaust airflow is unobstructed.

Chassis Weight

When lifting the system, follow these guidelines:

- Disconnect all power and external cables before lifting the system.
- Have two people to lift the system. The Cisco UCS 6332 weighs 22 pounds (9.9 kg). The Cisco UCS 6332 16-UP weighs 22.61 pounds (10.2 kg). The Cisco UCS 6454 weighs 25.9 pounds (11.7 kg)
- Ensure that your footing is solid and that the weight of the system is evenly distributed between your feet.

- Lift the system slowly, keeping your back straight. Lift with your legs, not with your back. Bend at the knees, not at the waist.

Installation Guidelines

When installing the Cisco UCS Fabric Interconnect, follow these guidelines:

- Prepare the site as described in the [Site Preparation Checklist, on page 71](#).
- Plan your site configuration and prepare the site before installing the chassis. [Site Preparation Checklist, on page 71](#) lists the recommended site planning tasks.
- Record the information listed in [Site Preparation Checklist, on page 71](#) as you install and configure the fabric interconnect.
- Ensure that there is adequate space around the chassis to allow for servicing and for adequate airflow. [Site Preparation Checklist, on page 71](#) lists airflow requirements.
- Ensure that the air conditioning meets the heat dissipation requirements listed in [Site Preparation Checklist, on page 71](#).



Note Jumper power cords are available for use in a cabinet. See [Cabinet Jumper Power Cords, on page 69](#).

- Ensure that the chassis is adequately grounded. If the chassis is not mounted in a grounded rack, Cisco recommends connecting both the system ground on the chassis and the power supply ground to an earth ground.
- Ensure that the site power meets the power requirements listed in [Power Specifications, on page 56](#). If available, you can use an uninterruptible power supply (UPS) to protect against power failures.

Avoid UPS types that use ferroresonant technology. These UPS types can become unstable with systems such as the Cisco UCS Fabric Interconnect, which can have substantial current draw fluctuations because of fluctuating data traffic patterns.

- Ensure that circuits are sized according to local and national codes. For North America, the power supply requires a 15-A or 20-A circuit.

To prevent loss of input power, ensure that the total maximum loads on the circuits supplying power to the fabric interconnect are within the current ratings for the wiring and breakers.

- Use the following screw torques (listed in Newton-metres) when installing the chassis:
 - Captive screws: 4 in-lb (0.45 N m)
 - M3 screws: 4 in-lb (0.45 N m)
 - M4 screws: 12 in-lb (1.36 N m)
 - 10-32 screws: 20 in-lb (2.26 N m)
 - 12-24 screws: 30 in-lb (3.39 N m)

Required Equipment

Before beginning the installation, ensure that the following items are ready:

- Number 1 and number 2 Phillips screwdrivers with torque capability
- 3/16-inch flat-blade screwdriver
- Tape measure and level
- ESD wrist strap or other grounding device
- Antistatic mat or antistatic foam

The following additional items (not found in the accessory kit) are required to ground the chassis:

- Grounding cable (6 AWG recommended), sized according to local and national installation requirements; the required length depends on the proximity of the Cisco UCS Fabric Interconnect to proper grounding facilities
- Crimping tool large enough to accommodate girth of lug
- Wire-stripping tool

Cabinet and Rack Requirements

This section provides the requirements for the following types of cabinets and racks, assuming an external ambient air temperature range of 0 to 104°F (0 to 40°C):

- Standard perforated cabinets (60 percent or greater perforation front and back is required; the Cisco R Series rack is an ideal choice)
- Standard open racks



Note If you are using an enclosed cabinet, we recommend one of the thermally validated types: standard perforated or solid-walled with a fan tray.



Note Do not use racks that have obstructions (such as power strips), because the obstructions could impair access to field-replaceable units (FRUs). The Cisco RP series PDUs when mounted in a Cisco R Series Rack should not obstruct FRU replacement.

General Requirements for Cabinets and Racks

The cabinet or rack must be one of the following types:

- Standard 19 in. (48.3 cm) (four-post EIA cabinet or rack, with mounting rails that conform to English universal hole spacing per section 1 of ANSI/EIA-310-D-1992. See the [Requirements Specific to Perforated Cabinets](#). (The Cisco R Series Rack is an ideal choice.)

The cabinet or rack must also meet the following requirements:

- The minimum vertical rack space per Cisco UCS 6332 chassis must be one RU (rack unit), equal to 1.75 in. (4.4 cm).
- The minimum vertical rack space per Cisco UCS 6332 16-UP chassis must be one RU (rack unit), equal to 1.75 in. (4.4 cm).
- The minimum vertical rack space per Cisco UCS 6454 chassis must be one RU (rack unit), equal to 1.75 in. (4.4 cm).
- The width between the rack-mounting rails must be at least 17.72 in. (45.0 cm) if the rear of the chassis is not attached to the rack. For four-post EIA racks, this is the distance between the two front rails.
- For four-post EIA cabinets (perforated):
 - The minimum spacing for the bend radius for fiber-optic cables should have the front-mounting rails of the cabinet offset from the front door by a minimum of 3 in. (7.6 cm), and a minimum of 5 in. (12.7 cm) if cable management brackets are installed on the front of the chassis.
 - The distance between the outside face of the front mounting rail and the outside face of the back mounting rail should be 23.5 to 34.0 in. (59.7 to 86.4 cm) to allow for rear-bracket installation.
 - A minimum of 2.5 in. (6.4 cm) of clear space should exist between the side edge of the chassis and the side wall of the cabinet. No sizeable flow obstructions should be immediately in the way of chassis air intake or exhaust vents.



Note Optional jumper power cords are available for use in a cabinet.

Requirements Specific to Perforated Cabinets

A perforated cabinet is defined here as a cabinet with perforated front and rear doors and solid side walls. In addition to the requirements listed in the [General Requirements for Cabinets and Racks, on page 20](#), perforated cabinets must meet the following requirements:

- The front and rear doors must have at least a 60 percent open area perforation pattern, with at least 15 square inches of open area per rack unit of door height.
- The roof should be perforated with at least a 20 percent open area.
- The cabinet floor should be open or perforated to enhance cooling.

The Cisco R Series racks meet or exceed all these requirements.

Requirements Specific to Standard Open Racks

In addition to the requirements listed in the [General Requirements for Cabinets and Racks, on page 20](#), if mounting the chassis in an open rack (no side panels or doors), the minimum vertical rack space per chassis must be one RU (rack unit), equal to 1.75 in. (4.4 cm).

The Cisco R Series racks meet or exceed all these requirements.

Cable Management Guidelines

To help with cable management, you might want to allow additional space in the rack above and below the chassis to make it easier to route as many as 56 fiber or copper cables through the rack.

Required Equipment

Before beginning the installation, ensure that the following items are ready:

- Number 1 and number 2 Phillips screwdrivers with torque capability
- 3/16-inch flat-blade screwdriver
- Tape measure and level
- ESD wrist strap or other grounding device
- Antistatic mat or antistatic foam

The following additional items (not found in the accessory kit) are required to ground the chassis:

- Grounding cable (6 AWG recommended), sized according to local and national installation requirements; the required length depends on the proximity of the Cisco UCS Fabric Interconnect to proper grounding facilities
- Crimping tool large enough to accommodate girth of lug
- Wire-stripping tool

Unpacking and Inspecting the Cisco UCS Fabric Interconnect

**Caution**

When handling chassis components, wear an ESD strap and handle modules by the carrier edges only. An ESD socket is provided on the chassis. For the ESD socket to be effective, the chassis must be grounded through the power cable, the chassis ground, or the metal-to-metal contact with a grounded rack.

**Tip**

Keep the shipping container in case the chassis requires shipping in the future.

**Note**

The interconnect is thoroughly inspected before shipment. If any damage occurred during transportation or any items are missing, contact your customer service representative immediately.

Procedure

-
- Step 1** Compare the shipment to the equipment list provided by your customer service representative and verify that you have received all items, including the following:
- Grounding lug kit
 - Rack-mount kit
 - ESD wrist strap
 - Cables with connectors
 - Any optional items ordered
- Step 2** Check for damage and report any discrepancies or damage to your customer service representative. Have the following information ready:
- Invoice number of shipper (see packing slip)
 - Model and serial number of the damaged unit
 - Description of damage
 - Effect of damage on the installation
-

Installing the Cisco UCS Chassis or UCS Chassis in a Cabinet or Rack

This section describes how to use the rack-mount kit provided with the chassis to install Cisco UCS into a cabinet or rack that meets the requirements described in [Cabinet and Rack Requirements, on page 20](#). All Cisco UCS Fabric Interconnects use the same installation procedure.



Caution If the rack is on wheels, ensure that the brakes are engaged or that the rack is otherwise stabilized.

This table lists the items contained in the rack-mount kit provided with the chassis.

Table 7: Chassis Rack-Mount Kit

Quantity	Part Description
2	Rack-mount brackets
12	M4x0.7 x 8-mm Phillips countersink screws
10	10-32 cage nuts
10	10-32 x 3/4-inch Phillips pan-head screws

Quantity	Part Description
2	Rack-mount guides
2	Slider rails

Procedure

Step 1 Install the front rack-mount brackets as follows:

Note The port side of the FI is the rear and it faces the rear of the rack. The fan side of the FI is the front and it faces the front of the rack. Cooling fans pull air front-to-rear. That is, air intake is on the fan side and air exhaust is on the port side.

- a) Position a front rack-mount bracket against the chassis and align the screw holes as shown below. You can attach the front rack-mount bracket at the front or the rear of the chassis, depending on which side you want to locate on the cold aisle. Then attach the front rack-mount bracket to the chassis with four M4 screws.

Note You can align any four of the holes in the front rack-mount bracket to four of the six screw holes on the side of the chassis. The holes that you use depend on the requirements of your rack and the amount of clearance required for interface cables and power supply handles.

- b) Repeat Step 1 for the other front rack-mount bracket on the other side of the chassis.

Figure 10: Attaching the Rack-Mount Brackets to the Chassis

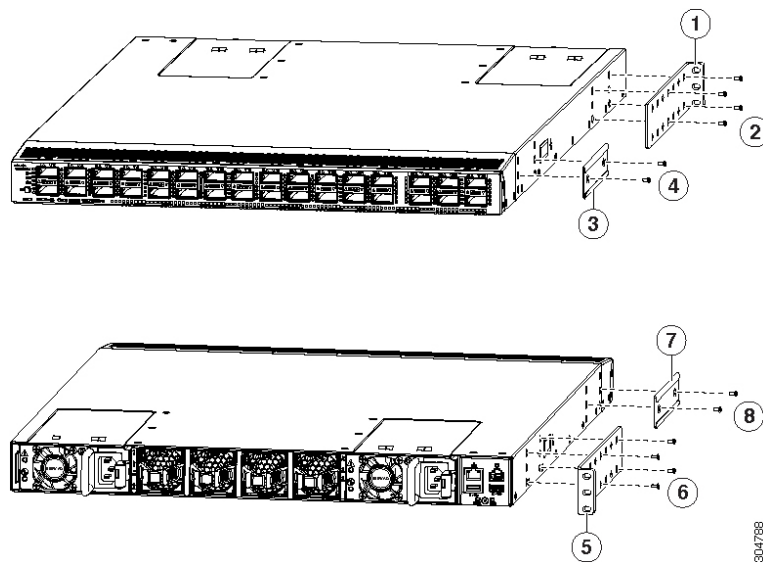

1	Front rack-mount bracket aligned to the rear of the chassis	2	Four M4 screws used to attach the bracket to the chassis
---	---	---	--

3	Rear rack-mount guide aligned to the front of the chassis	4	Two M4 screws used to attach the brackets
5	Front rack-mount bracket aligned to the front of the chassis	6	Four M4 screws used to attach the bracket to the chassis
7	Rear rack-mount guide	8	Two M4 screws used to attach the bracket to the chassis

Step 2 Install the rear rack-mount guides on the chassis as follows:

- Align the two screw holes on a rear rack-mount bracket to the middle two screw holes in the remaining six screw holes on a side of the chassis. If you are aligning the bracket to holes that are near the front end of the chassis, see callout 3 in the previous figure. Otherwise, see callout 7 in the previous figure.
- Attach the bracket to the chassis with two of the flat-head M4 screws. See callout 4 or 8 in the previous figure.
- Repeat Step 2 with the other rear rack-mount bracket on the other side of the chassis.

Step 3 Attach the slider rails to the rack. Use 2 12-24 screws or 2 10-32 screws, depending on the rack rail thread type. For racks with square holes, insert the 12-24 cage nuts in position behind the mounting holes in the slider rails.

- Repeat with the other slider rail on the other side of the rack.
- Use the tape measure and level to verify that the rails are horizontal and at the same height.

Figure 11: Installing the Slider Rails

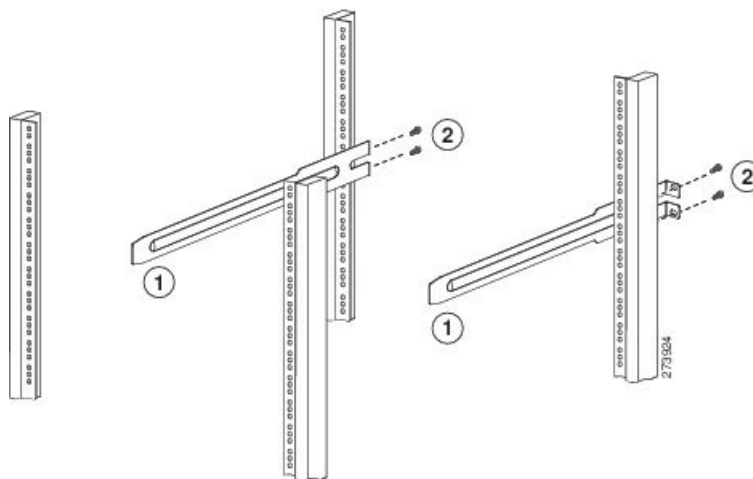

Step 4 Insert the chassis into the rack:

- Holding the chassis with both hands, position the two rear rack-mount brackets on the chassis between the two posts that do not have slider rails attached to them (see the following figure).
- Align the two rear rack-mount guides on either side of the chassis with the slider rails installed in the rack. Slide the rack-mount glides onto the slider rails, and then gently slide the chassis all the way into the rack. If the chassis does not slide easily, try realigning the rack-mount glides on the slider rails.

Figure 12: Sliding the Chassis Into the Rack

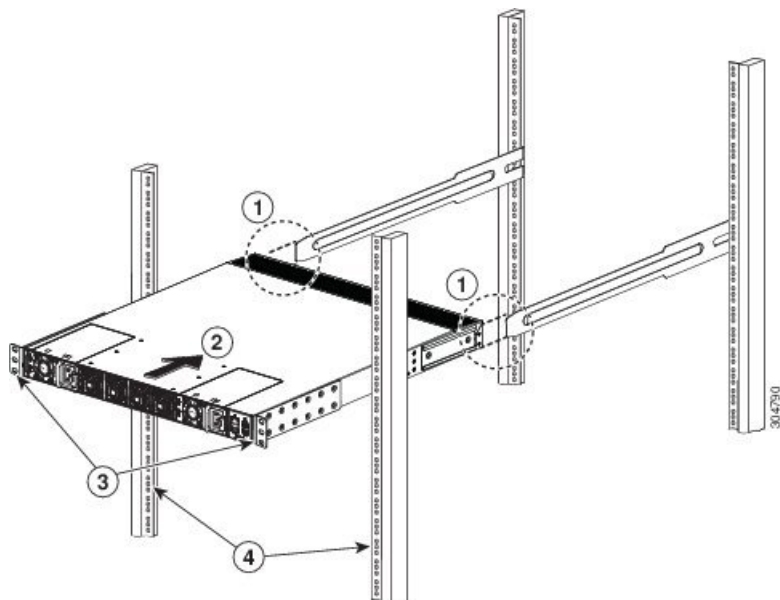
**Step 5**

Stabilize the chassis in the rack by attaching the front rack-mount brackets to the front rack-mounting rails:

- a) Insert 2 screws (12-24 or 10-32, depending on rack type) in each the two front rack-mount brackets (using a total of four screws) and into the threaded holes in the vertical rack-mounting rail.
- b) Repeat for the front rack-mount bracket on the other side of the chassis.

Figure 13: Attaching the Chassis to the Rack

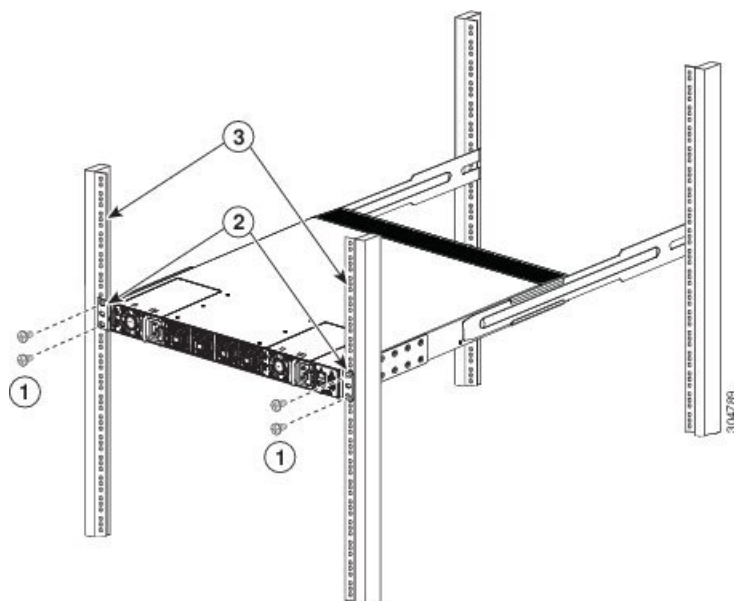

Grounding the System

Proper Grounding Practices

Grounding is one of the most important parts of equipment installation. When you properly ground systems during installation, you reduce or prevent shock hazards, equipment damage due to transients, and data corruption.

Table 8: Proper Grounding Guidelines

Environment	Electromagnetic Noise Severity Level	Grounding Recommendations
Commercial building is subjected to direct lightning strikes. For example, some places in the United States, such as Florida, are subject to more lightning strikes than are other areas.	High	All lightning protection devices must be installed in strict accordance with manufacturer recommendations. Conductors carrying lightning current should be spaced away from power and data lines in accordance with applicable recommendations and codes. Best grounding recommendations must be closely followed.
Commercial building is located in an area where lightning storms frequently occur but is not subject to direct lightning strikes.	High	Best grounding recommendations must be closely followed.
Commercial building contains a mix of information technology equipment and industrial equipment, such as welding.	Medium to high	Best grounding recommendations must be closely followed.
Existing commercial building is not subject to natural environmental noise or man made industrial noise. This building contains a standard office environment. This installation has a history of malfunction due to electromagnetic noise.	Medium	Determine source and cause of noise if possible, and mitigate as closely as possible at the noise source or reduce coupling from the noise source to the affected equipment. Best grounding recommendations must be closely followed.

Environment	Electromagnetic Noise Severity Level	Grounding Recommendations
New commercial building is not subject to natural environmental noise or man-made industrial noise. This building contains a standard office environment.	Low	Electromagnetic noise problems are not anticipated, but installing a grounding system in a new building is often the least expensive route and the best way to plan for the future. Best grounding recommendations should be followed as closely as possible.
Existing commercial building is not subject to natural environmental noise or man-made industrial noise. This building contains a standard office environment.	Low	Electromagnetic noise problems are not anticipated, but installing a grounding system is always recommended. Best grounding recommendations should be followed as much as possible.



Note In all situations, grounding practices must comply with local National Electric Code (NEC) requirements or local laws and regulations.



Note Always ensure that all of the modules are completely installed and that the captive installation screws are fully tightened. In addition, ensure that all I/O cables and power cords are properly seated. These practices are normal installation practices and must be followed in all installations.

Preventing Electrostatic Discharge Damage

Electrostatic discharge (ESD) damage, which can occur when modules or other devices are improperly handled, results in intermittent or complete failures. Modules consist of printed circuit boards that are fixed in metal carriers. Electromagnetic interference (EMI) shielding and connectors are integral components of the carrier. Although the metal carrier helps to protect the board from ESD, always use an ESD grounding strap when handling modules.

For preventing ESD damage, follow these guidelines:

- Always use an ESD wrist strap and ensure that it makes maximum contact with bare skin.
- ESD grounding straps are available with banana plugs, metal spring clips, or alligator clips. All Cisco UCS 6300 Series Fabric Interconnect chassis are equipped with a banana plug connector (identified by the ground symbol next to the connector) somewhere on the front panel. We recommend that you use a personal ESD grounding strap equipped with a banana plug.
- If you choose to use the disposable ESD wrist strap supplied with most field-replaceable units or an ESD wrist strap equipped with an alligator clip, you must attach the system ground lug to the chassis in order to provide a proper grounding point for the ESD wrist strap.



Note This system ground is also referred to as the network equipment building system (NEBS) ground.

- If your chassis does not have the system ground attached, you must install the system ground lug. See the [Establishing the System Ground, on page 30](#) for installation instructions and location of the chassis system ground pads.



Note You do not need to attach a supplemental system ground wire to the system ground lug; the lug provides a direct path to the bare metal of the chassis.

Before you install the system ground lug, you must correctly attach the ESD wrist strap.

Procedure

- Step 1** Attach the ESD wrist strap to bare skin as follows:
- a) If you are using the ESD wrist strap supplied with the FRUs, open the wrist strap package and unwrap the ESD wrist strap. Place the black conductive loop over your wrist and tighten the strap so that it makes good contact with your bare skin.
 - b) Open the package and remove the ESD wrist strap. Locate the end of the wrist strap that attaches to your body and secure it to your bare skin.
- Step 2** Grasp the spring or alligator clip and momentarily touch the clip to a bare metal spot, such as an unpainted rack rail, to safely dissipate any built-up static charge to the entire rack.
- Step 3** Attach the ESD strap to the system ground in one of the following ways:
- If you are using a wrist strap that is equipped with a plug, insert the plug into an open screw hole used for the grounding lug.
 - If you are using a wrist strap with spring or alligator clips, attach either the spring clip or the alligator clip to the ground lug screw:

If you are using the ESD wrist strap that is supplied with the FRUs, squeeze the spring clip jaws open, position the spring clip to one side of the system ground lug screw head, and slide the spring clip over the lug screw head so that the spring clip jaws close behind the lug screw head.

Note The spring clip jaws do not open wide enough to fit directly over the head of the lug screw or the lug barrel.

If you are using an ESD wrist strap that is equipped with an alligator clip, attach the alligator clip directly over the head of the system ground lug screw or to the system ground lug barrel.

In addition, follow these guidelines when handling components:

- Handle carriers by available handles or edges only; avoid touching the printed circuit boards or connectors.

- Place a removed component board-side-up on an antistatic surface or in a static-shielding container. If you plan to return the component to the factory, immediately place it in a static-shielding container.
- Never attempt to remove the printed circuit board from the metal carrier.



Caution For safety, periodically check the resistance value of the antistatic strap. The measurement should be between 1 and 10 megohm (Mohm).

Establishing the System Ground



Note This system ground is referred to as the network equipment building system (NEBS) ground.

You must use the NEBS ground on AC-powered systems if you are installing this equipment in a U.S. or European Central Office.

The NEBS ground provides additional grounding for EMI shielding requirements and grounding for the low-voltage supplies (DC-DC converters) on the modules, and is intended to satisfy the Telcordia Technologies NEBS requirements for supplemental bonding and grounding connections. You must observe the following system grounding guidelines for your chassis:

- You must install the NEBS ground connection with any other rack or system power ground connections that you make. The system ground connection is required if this equipment is installed in a U.S. or European Central Office.
- You must connect both the NEBS ground connection and the power supply ground connection to an earth ground. The NEBS ground connection is required if this equipment is installed in a U.S. or European Central Office.
- You do not need to power down the chassis because this device is equipped with AC-input power supplies.

Required Tools and Equipment

To connect the system ground, you need the following tools and materials:

- Grounding lug—A two-hole standard barrel lug. Supports up to 6 AWG wire. Supplied as part of accessory kit.
- Grounding screws—Two M4 x 8mm (metric) pan-head screws. Supplied as part of the accessory kit.
- Grounding wire—Not supplied as part of accessory kit. The grounding wire should be sized according to local and national installation requirements. Depending on the power supply and system, a 12 AWG to 6 AWG copper conductor is required for U.S. installations. Commercially available 6 AWG wire is recommended. The length of the grounding wire depends on the proximity of the chassis to proper grounding facilities.
- No. 1 Phillips head screwdriver.
- Crimping tool to crimp the grounding wire to the grounding lug.

- Wire-stripping tool to remove the insulation from the grounding wire.

Grounding the Fabric Interconnect

The chassis has a grounding pad with two threaded M4 holes for attaching a grounding lug.

**Warning**

When installing or replacing the unit, the ground connection must always be made first and disconnected last. Statement 1046

**Caution**

We recommend grounding the chassis, even if the rack is already grounded.

**Caution**

All power supplies must be grounded. The receptacles of the AC power cables used to provide power to the chassis must be the grounding type, and the grounding conductors should connect to protective earth ground at the service equipment.

**Warning**

When installing or replacing the unit, the ground connection must always be made first and disconnected last. Statement 1046

**Caution**

Grounding the chassis is required if you are using DC power supplies, even if the rack is already grounded. A grounding pad with two threaded M4 holes is provided on the chassis for attaching a grounding lug. The ground lug must be NRTL listed. In addition, the copper conductor (wires) must be used and the copper conductor must comply with NEC code.

Procedure

- Step 1** Use a wire-stripping tool to remove approximately 0.75 inches (19 mm) of the covering from the end of the grounding cable.
- Step 2** Insert the stripped end of the grounding cable into the open end of the grounding lug.
- Step 3** Use the crimping tool to secure the grounding cable in the grounding lug.
- Step 4** Remove the adhesive label from the grounding pad on the chassis.

Figure 14: Connecting the System Ground

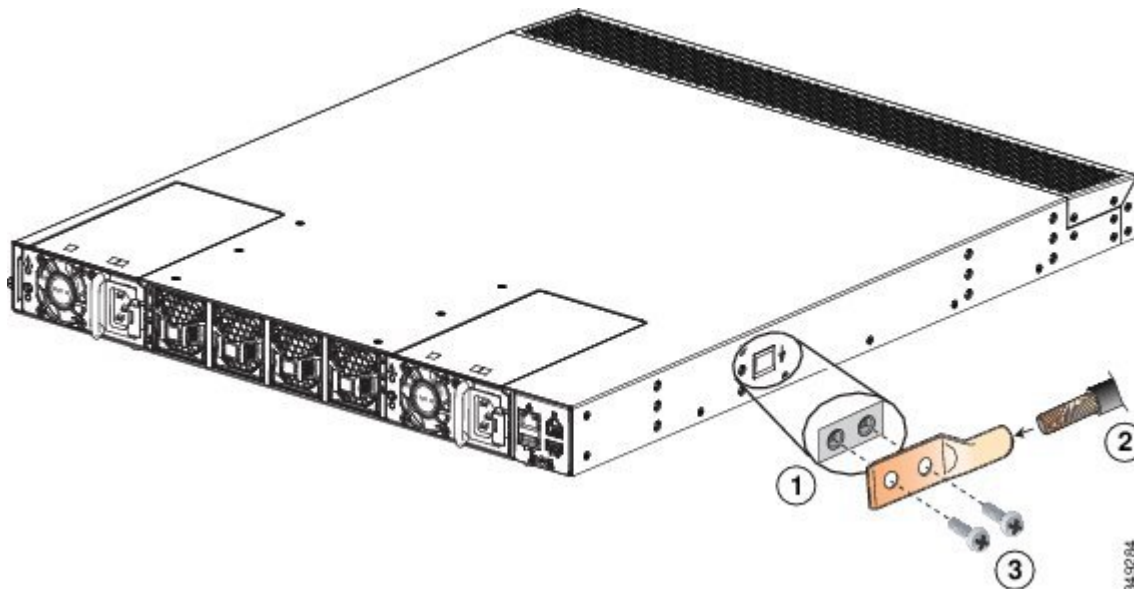

Item	Description
1	Grounding Pad
2	Grounding Cable
3	M4 Screws

- Step 5** Place the grounding lug against the grounding pad so that there is solid metal-to-metal contact, and insert the two M4 screws with washers through the holes in the grounding lug and into the grounding pad.
- Step 6** Ensure that the lug and cable do not interfere with other equipment.
- Step 7** Prepare the other end of the grounding cable and connect it to an appropriate grounding point in your site to ensure adequate earth ground.

Starting the System



Note Do not connect the Ethernet port to the LAN until the initial system configuration has been performed. For instructions on configuring the system, see the *Configuration Guide* for the version of Cisco UCS Manager that you are using. The configuration guides are available at this URL:

<http://www.cisco.com/c/en/us/support/servers-unified-computing/ucs-manager/products-installation-and-configuration-guides-list.html>

**Warning**

When installing or replacing the unit, the ground connection must always be made first and disconnected last. Statement 1046

**Warning**

The plug-socket combination must be accessible at all times, because it serves as the main disconnecting device. Statement 1019

Procedure

- Step 1** Verify that empty power supply slots have filler panels installed, the faceplates of all modules are flush with the front of the chassis, and the captive screws of the power supplies, fan module, and all expansion modules are tight.
- Step 2** Verify that the power supply and the fan modules are installed. (See [Replacing or Installing Power Supplies, on page 34](#) if necessary.)
- Note** Depending on the outlet receptacle on your power distribution unit, you may need the optional jumper power cord to connect the Cisco UCS Fabric Interconnect to your outlet receptacle. See [Cabinet Jumper Power Cords, on page 69](#).
- Step 3** Ensure that the chassis is adequately grounded, and that the AC or DC power available has the required power voltages (see [Power Specifications, on page 56](#)). For a DC installation, see [Wiring a DC Power Connector, on page 36](#) to correctly wire the DC connector before applying a DC cable.
- Step 4** For a first-time installation, you will need to work with your network manager to determine the following parameters:
- System name
 - Password for the admin account. Choose a strong password that meets the guidelines for Cisco UCS Manager passwords. This password can not be blank.
 - Management port IP address and subnet mask
 - Default gateway IP address
 - DNS server IP address (optional)
 - Domain name for the system (optional)
- Step 5** Connect a PC or laptop directly to the console port of the primary or standalone fabric interconnect. In a cluster configuration, the primary will be the fabric interconnect that powers up first. The console port on the terminal should be set to 9600 baud, 8 data bits, no parity, 1 stop bit.
- Step 6** If the fabric interconnect will be running in a cluster with another fabric interconnect, you will need to connect Ethernet cables between the L1 and L2 ports. Port L1 on fabric interconnect A connects to L1 on fabric interconnect B, and Port L2 on fabric interconnect A connects to L2 on fabric interconnect B. If the fabric interconnect and the UCS instance will be in standalone mode this will not be necessary.
- Step 7** Connect the power cable to a power source. The system should power on as soon as you connect the AC power cable, HVDC power cable, or DC power connector.

- Step 8** Listen for the fans; they should begin operating when you plug in the power cable.
- Step 9** After the system boots, verify that the LED operation is as follows:
- Fan module—Status LED is green.
 - Power supply—Status LED is green.
 - After initialization, the system status LED is green, indicating that all chassis environmental monitors are reporting that the system is operational. If this LED is orange or red, then at least one environmental monitor is reporting a problem.
 - The Link LEDs for the Ethernet connector should not be on unless the cable is connected.
- Note** The link LEDs for the Fibre Channel ports remain yellow until the ports are enabled, and the LED for the Ethernet connector port remains off until the port is connected.
- Step 10** If there is a problem, try removing and reinstalling a component that is not operating correctly. If it still does not operate correctly, contact your customer service representative for a replacement.
- Note** If you purchased this product through a Cisco reseller, contact the reseller directly for technical support. If you purchased this product directly from Cisco, contact Cisco Technical Support at this URL: http://www.cisco.com/en/US/support/tsd_cisco_worldwide_contacts.html.
- Step 11** Verify that the system software has booted and that the system has initialized without error messages. If you cannot resolve an issue, contact your customer service representative.
- Step 12** Complete the worksheets provided in [Site Preparation Checklist, on page 71](#) for future reference.
- Step 13** Configure the primary fabric interconnect as described in the *Configuration Guide* for the version of Cisco UCS Manager that you are using. The configuration guides are available at this URL: <http://www.cisco.com/c/en/us/support/servers-unified-computing/ucs-manager/products-installation-and-configuration-guides-list.html>
- Step 14** Power up the primary fabric interconnect, connect the terminal to the console port, and configure the secondary fabric interconnect as described in the Cisco UCS Manager *Configuration Guide*.

Replacing or Installing Components



Caution To prevent ESD damage, wear grounding wrist straps during these procedures and handle modules by the carrier edges only.

Replacing or Installing Power Supplies

The Cisco UCS Fabric Interconnect supports two front-end AC, DC, or HVDC power supplies, but may be used with one power supply. Mixing of AC, DC, or HVDC power supplies is not supported. If you need to replace an existing power supply, follow the procedures that explain how to remove and install power supplies. If you are installing a new power supply where one did not exist before, follow the installation procedure. See [Installing a Power Supply, on page 35](#).



Note You can replace a faulty power supply while the system is operating provided that the other power supply is functioning.

Removing a Power Supply



Caution If you are using the Cisco UCS Fabric Interconnect with one power supply, removing the power supply causes the system to shut down. If you are using two power supplies and you remove one of them, the system continues to operate.

Procedure

- Step 1** Ensure that the system (earth) ground connection has been made.
 - Step 2** Remove the AC power cord, HVDC power cord, or DC wiring connector.
 - Step 3** Grasp the power supply handle with your left hand.
 - Step 4** Push against the release latch with your left thumb and slide the power supply out of the chassis.
 - Step 5** Place your right hand under the power supply to support it while you slide it out of the chassis.
 - Step 6** If you are not replacing the power supply, install a blank power supply filler panel. If you are replacing the power supply, proceed to [Installing a Power Supply, on page 35](#).
-

Installing a Power Supply

Procedure

- Step 1** Ensure that the system (earth) ground connection has been made.
- Step 2** If the power supply bay has a filler panel, press the latches on the sides of the filler panel, and then slide it out of the power supply bay.
- Step 3** Hold the power supply by the handle and position it so that the release latch is on the right, and then slide it into the power supply bay, ensuring that the power supply is fully seated in the bay.
- Step 4** Plug the AC power cable, HVDC power cable, or DC wiring connector into the inlet receptacle at the rear of the chassis. For a DC installation, you should secure the plug to the power supply by tightening both captive screws on the plug.
 - Note** Depending on the outlet receptacle on your power distribution unit, you may need the optional jumper power cord to connect the Cisco UCS Fabric Interconnect to your outlet receptacle. See [Cabinet Jumper Power Cords, on page 69](#).
- Step 5** Connect the other end of the power cable or cables to a power source. DC sources should connect negative (black wire) and then positive (red wire) connections.

In a system with dual power supplies, connect each power supply to a separate power source. In case of a power source failure, the second source will most likely still be available.

Step 6 Verify power supply operation by checking that the power supply LED is green.

Wiring a DC Power Connector



Warning A readily accessible two-poled disconnect device must be incorporated in the fixed wiring. Statement 1022



Warning This product requires short-circuit (overcurrent) protection, to be provided as part of the building installation. Install only in accordance with national and local wiring regulations. Statement 1045



Warning When installing or replacing the unit, the ground connection must always be made first and disconnected last. Statement 1046



Warning Installation of the equipment must comply with local and national electrical codes. Statement 1074



Warning Hazardous voltage or energy may be present on DC power terminals. Always replace cover when terminals are not in service. Be sure uninsulated conductors are not accessible when cover is in place. Statement 1075

Before installing a DC power supply to the fabric interconnect, you must attach DC connection wires that you provide (10 GA recommended) to the DC power connector included in the DC power supply's accessory kit.

Procedure

- Step 1** Using a 1/8-inch flat head screwdriver or No. 1 Phillips head screwdriver, loosen the set screws on the connector to freely accept the power wires. The connector will accept 8-24 AWG wires. Use what your local electrical code requires.
- Step 2** Strip 1/2-inch of insulation off the DC wires you will use.
- Step 3** Insert the black (DC negative) wire into the right aperture on the connector and tighten down the connection set screw. Finger tight or about 3 ft./lbs should be sufficient.
- Step 4** Insert the red (DC positive) wire into the left aperture on the connector and tighten down the connection set screw. Do not tighten over 0.51 ft./lbs.

Figure 15: Wiring the DC Power Connector

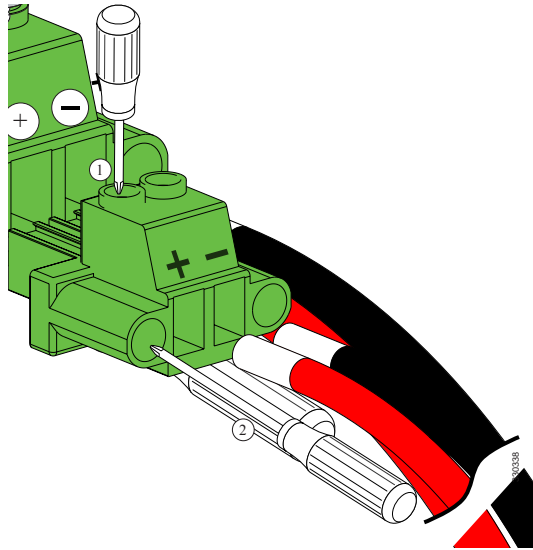

Fan Modules

Replacing a Fan Module



Warning

When removing the fan tray, keep your hands and fingers away from the spinning fan blades. Let the fan blades completely stop before you remove the fan tray. Statement 258

Procedure

- Step 1** Ensure that the system (earth) ground connection has been made.
- Step 2** Loosen the captive screws on the fan module by turning them counterclockwise, using a flat-blade or number 2 Phillips head screwdriver if required.
- Step 3** Squeeze together the handles of the fan module and pull it outward.
- Step 4** Pull the fan module clear of the chassis and set it down on antistatic foam or place it in an antistatic bag.
- Step 5** Hold the replacement fan module with the LED at the bottom.
- Step 6** Place the fan module into the front chassis cavity so it rests on the chassis. Then push the fan module into the chassis as far as it can go and the captive screw makes contact with the chassis. Tighten the captive screw.
- Step 7** Listen for the fans. If the system is powered on, you should immediately hear them operating. If you do not hear them, ensure that the fan module is inserted completely in the chassis and the faceplate is flush with the outside surface of the chassis.
- Step 8** Verify that the LED is green. If the LED is not green, one or more fans are faulty. If this occurs, contact your customer service representative for a replacement part.

Note If you purchased this product through a Cisco reseller, contact the reseller directly for technical support. If you purchased this product directly from Cisco, contact Cisco Technical Support at this URL: http://www.cisco.com/en/US/support/tsd_cisco_worldwide_contacts.html.

Preparing a Fabric Interconnect for Removal

Removing a standby fabric interconnect is non-disruptive in a redundant Cisco UCS configuration. Removing an active fabric interconnect will cause the standby fabric interconnect to become active with minimal or no disruption.



Caution Be aware that if you remove both the active and standby fabric interconnect, or the sole fabric interconnect from a standalone system, you are shutting down the entire Cisco UCS domain.

Procedure

Step 1 Use Cisco UCS Manager to perform the following tasks:

- a) Back up your Cisco UCS Manager configuration.
- b) Shut down the OS on all servers in the Cisco UCS domain.
- c) Disable the Smart Call Home feature in the Cisco UCS domain.
- d) Decommission every attached chassis in the Cisco UCS domain.

For details, see the *Configuration Guide* for the version of Cisco UCS Manager that you are using. The configuration guides are available at this URL: <http://www.cisco.com/c/en/us/support/servers-unified-computing/ucs-manager/products-installation-and-configuration-guides-list.html>.

Step 2 Power down every attached chassis as described in the [Cisco UCS 5108 Server Chassis Hardware Installation Guide](#).

When powering down and removing clustered fabric interconnects, remove the secondary fabric interconnect first, and then remove the primary fabric interconnect.

Removing a Cisco UCS Fabric Interconnect



Caution The slider rail and front rack-mount brackets do not have a stop mechanism when sliding in and out. If the front of the chassis is unfastened from the rack and the chassis slides forward on the slider rails, it may slip off the end of the rails and fall out of the rack.

Procedure

- Step 1** Ensure that the weight of the Cisco UCS Fabric Interconnect is fully supported and that the chassis is being held by another person.
 - Step 2** Remove the two screws holding the grounding cable to the chassis.
 - Step 3** Disconnect the power cord and the console cables.
 - Step 4** Disconnect all cables that are connected to SFP28 transceivers.
 - Step 5** Remove the screws fastening the front rack-mount brackets to the mounting rails.
 - Step 6** Gently slide the Cisco UCS Fabric Interconnect toward you, off of the slider rails and out of the rack.
-

Removing a Cisco UCS 6332 16-UP Fabric Interconnect



- Caution** The slider rail and front rack-mount brackets do not have a stop mechanism when sliding in and out. If the front of the chassis is unfastened from the rack and the chassis slides forward on the slider rails, it may slip off the end of the rails and fall out of the rack.
-

Procedure

- Step 1** Ensure that the weight of the Cisco UCS 6332 16-UP is fully supported and that the chassis is being held by another person.
 - Step 2** Remove the two screws holding the grounding cable to the chassis.
 - Step 3** Disconnect the power cord and the console cables.
 - Step 4** Disconnect all cables that are connected to SFP+ transceivers.
 - Step 5** Remove the screws fastening the front rack-mount brackets to the mounting rails.
 - Step 6** Gently slide the Cisco UCS 6332 16-UP toward you, off of the slider rails and out of the rack.
-

Replacing a Fabric Interconnect

Use the following procedure when you need to replace a single fabric interconnect with the same model of fabric interconnect.

Use Cisco UCS Manager, either the GUI or the CLI, to perform the software-related tasks mentioned in the following procedure. For additional information, refer to the *Cisco UCS Manager Getting Started Guide*, the *Cisco UCS Manager Infrastructure Management Guide*, and the instructional videos available at this URL: <http://www.cisco.com/c/en/us/support/servers-unified-computing/ucs-manager/products-installation-and-configuration-guides-list.html>

As a best practice, perform a full configuration backup before replacing the fabric interconnect.

Procedure

- Step 1** Contact Cisco TAC or your Cisco Sales representative to have them transfer the license to the replacement fabric interconnect.
- Step 2** Label the ports and the cables that you using so that you can refer to this information later. The cabling and port numbering should be same for the replacement fabric interconnect.
- Step 3** Log into UCS Manager and verify the state of the fabric interconnect, either active or subordinate. From the CLI, enter the **show cluster extended-state** command. High availability (HA) should be running in UCS Manager.

Example:

```

FI-A# show cluster extended-state
Cluster Id: 0x537d0580bf9911e0-0x8955000decd07984

A: UP, PRIMARY
B: UP, SUBORDINATE

A: memb state UP, lead state PRIMARY, mgmt services state: UP
B: memb state UP, lead state SUBORDINATE, mgmt services state: UP
  heartbeat state PRIMARY_OK

INTERNAL NETWORK INTERFACES:
eth1, UP
eth2, UP

HA READY <<<<<<<<<<<<<<<<<<<<<<<<<<<<<<<<<<<<<<<<<<<<<<<<<<<<<<<<<<<<----- HA is READY
Detailed state of the device selected for HA storage:
Chassis 1, serial: FOX1344G1R1, state: active
Chassis 2, serial: FOX1318GDKR, state: active
FI-A#

```

- Step 4** Back up the software configuration.
- Step 5** Use the fabric evacuation procedure on the subordinate fabric interconnect to ensure there is no data traffic impact during the hardware replacement.
- Step 6** Power down the subordinate fabric interconnect by unplugging it from the power source.

Example:

```

FI-A# show cluster extended-state
Cluster Id: 0x537d0580bf9911e0-0x8955000decd07984

A: UP, PRIMARY
B: DOWN, INAPPLICABLE

A: memb state UP, lead state PRIMARY, mgmt services state: UP
B: memb state DOWN, lead state INAPPLICABLE, mgmt services state: DOWN
  heartbeat state SECONDARY_FAILED

INTERNAL NETWORK INTERFACES:
eth1, DOWN
eth2, DOWN

HA NOT READY
Peer Fabric Interconnect is down
Detailed state of the device selected for HA storage:
Chassis 1, serial: FOX1344G1R1, state: active
Chassis 2, serial: FOX1318GDKR, state: active
FI-A#

```

- Step 7** Disconnect the cables from the front and back of the fabric interconnect and remove it. Follow the instructions in this section for removing a fabric interconnect.
- Step 8** Install the replacement fabric interconnect. Follow the instructions in this section for installing the fabric interconnect.
- Step 9** Connect the management and console cables to the replacement fabric interconnect.
- Step 10** Connect the L1/L2 cables that were disconnected to the replacement fabric interconnect.
- Step 11** Connect the data cable according to the labels that you created in Step 2.
- Step 12** Connect the power cable to the fabric interconnect and it will automatically boot and run POST tests.

```
---- Basic System Configuration Dialog ----
```

```
This setup utility will guide you through the basic configuration of
the system. Only minimal configuration including IP connectivity to
the Fabric interconnect and its clustering mode is performed through these steps.
```

```
Type Ctrl-C at any time to abort configuration and reboot system.
To back track or make modifications to already entered values,
complete input till end of section and answer no when prompted
to apply configuration.
```

```
Enter the configuration method. (console/gui) ? console
```

```
Installer has detected the presence of a peer Fabric interconnect.
This Fabric interconnect will be added to the cluster. Continue (y/n) ? y
```

```
Enter the admin password of the peer Fabric interconnect:
Connecting to peer Fabric interconnect... done
Retrieving config from peer Fabric interconnect... done
Peer Fabric interconnect Mgmt0 IP Address: 122.255.252.2
Peer Fabric interconnect Mgmt0 IP Netmask: 255.255.255.0
Cluster IP address          : 122.255.252.1
```

```
Physical Switch Mgmt0 IPv4 address : 122.255.252.3
```

```
Apply and save the configuration (select 'no' if you want to re-enter)? (yes/no): yes
Applying configuration. Please wait.
Configuration file - Ok
```

```
Cisco UCS 6300 Series Fabric Interconnect
```

```
FI-B login:
```

- Step 13** If necessary, upgrade the UCS Manager software. If the replacement fabric interconnect is not running the same firmware version as the cluster, the setup utility can upgrade the firmware.

Example:

```
---- Basic System Configuration Dialog ----
```

```
This setup utility will guide you through the basic configuration of
the system. Only minimal configuration including IP connectivity to
the Fabric interconnect and its clustering mode is performed through
these steps.
```

```
Type Ctrl-C at any time to abort configuration and reboot system.
To back track or make modifications to already entered values,
complete input till end of section and answer no when prompted
to apply configuration.
```

```

Enter the configuration method. (console/gui) ? console

Installer has detected the presence of a peer Fabric interconnect.
This Fabric interconnect will be added to the cluster. Continue (y/n) ? y

Enter the admin password of the peer Fabric interconnect:
Connecting to peer Fabric interconnect... done
Retrieving config from peer Fabric interconnect... done
Installer has determined that the peer Fabric Interconnect is
running a different firmware version than the local Fabric.
Cannot join cluster.

Local Fabric Interconnect
  UCSM version      : 3.1(2c)
  Kernel version    : 5.0(3)N2(3.12b)
  System version    : 5.0(3)N2(3.12b)
  local_model_no    : UCS-FI-6332

Peer Fabric Interconnect
  UCSM version      : 3.1(2c)
  Kernel version    : 5.0(3)N2(3.12c)
  System version    : 5.0(3)N2(3.12c)
  peer_model_no     : UCS-FI-6332

Do you wish to update firmware on this Fabric Interconnect to the
Peer's version? (y/n): y
Updating firmware of Fabric Interconnect.....
[ Please don't press Ctrl+c while updating firmware ]

Updating images
Please wait for firmware update to complete.

<output truncated>

Install has been successful.
Firmware Updation Successfully Completed. Please wait to enter the IP address
Peer Fabric interconnect Mgmt0 IPv4 Address: xx.xx.xx.xx
Peer Fabric interconnect Mgmt0 IPv4 Netmask: xx.xx.xx.xx
Cluster IPv4 address          : xx.xx.xx.xx

Peer FI is IPv4 Cluster enabled. Please Provide Local
Fabric Interconnect Mgmt0 IPv4 Address

Physical Switch Mgmt0 IP address : xx.xx.xx.xx

Apply and save the configuration (select 'no' if you want to re-enter)?
(yes/no): yes
Applying configuration. Please wait.

Fri Dec  9 19:57:15 UTC 2016
Configuration file - Ok

```

Step 14 Enter the **show cluster extended-state** command to revalidate the cluster state and verify that HA is ready.

Example:

```

FI-A# show cluster extended-state
Cluster Id: 0x537d0580bf9911e0-0x8955000decd07984

A: UP, PRIMARY
B: UP, SUBORDINATE

```

```
A: memb state UP, lead state PRIMARY, mgmt services state: UP
B: memb state UP, lead state SUBORDINATE, mgmt services state: UP
  heartbeat state PRIMARY_OK
```

```
INTERNAL NETWORK INTERFACES:
eth1, UP
eth2, UP
```

```
HA READY <<<<<<<<<<<<----- HA is READY
Detailed state of the device selected for HA storage:
Chassis 1, serial: FOX1344G1R1, state: active
Chassis 2, serial: FOX1318GDKR, state: active
FI-A#
```

- Step 15** Disable fabric evacuation and verify that traffic is flowing in both fabric interconnects.
- Step 16** Apply the port license to the fabric interconnect.
-

Repacking the Cisco UCS Fabric Interconnect for Return Shipment

If you need to return the fabric interconnect, remove the chassis from the rack by following the steps in [Removing a Cisco UCS Fabric Interconnect, on page 38](#), and repack it for shipment. If possible, use the original packing materials and container to repack the chassis. Contact your Cisco customer service representative to arrange for return shipment to Cisco.



CHAPTER 3

Connecting the Cisco UCS 6300 Series Fabric Interconnect

- [Preparing for Network Connections, on page 45](#)
- [Connecting to the Console Port, on page 46](#)
- [Connecting the Management Port, on page 47](#)
- [Connecting to an SFP+ Ethernet or Fibre Channel Port, on page 47](#)
- [Connecting to a Fibre Channel Port, on page 50](#)
- [Maintaining SFP28 Transceivers and Fiber-Optic Cables, on page 53](#)

Preparing for Network Connections

The Cisco UCS 6300 Series Fabric Interconnect provides the following types of ports:

- RS-232 port to create a local management connection.
- Ethernet ports, encrypted and unencrypted, to connect to a LAN.
- Fibre Channel ports to connect to a SAN.

When preparing your site for network connections to the Cisco UCS 6300 Series Fabric Interconnect, consider the following for each type of interface, and gather all the required equipment before connecting the ports:

- Cabling required for each interface type
- Distance limitations for each signal type
- Additional interface equipment required



Tip You can save time and confusion when making cabling changes if you make a copy of the [Chassis and Module Information, on page 74](#) and keep it accurate for your current configuration.

Connecting to the Console Port



Caution You can connect the console port to a modem. If you do not connect it to a modem, connect it either before powering on the system or after the system has completed the boot process.

The console port on a Cisco UCS fabric interconnect provides an RS-232 serial connection over an RJ-45 interface. This interface can be used for the following tasks:

- Perform initial setup on a newly installed system that does not yet have other connectivity options
- Perform software recovery tasks when other connectivity is unavailable
- Monitor network statistics and errors
- Configure SNMP agent parameters
- Download software updates

Any device connected to this port must be capable of asynchronous transmission.

Before you begin

You may have to acquire some or all of the following:

- The Cisco serial console management cable.
- A USB to DB9 serial adapter and any drivers the adapter requires.
- Terminal emulation software such as PuTTY, HyperTerminal or Procomm Plus.
- A computer that can support VT100 terminal emulation.

Procedure

Step 1 Plug the RJ-45 end of the serial management cable into the console port on the fabric interconnect, and connect the DB-9 male end into the serial port on a laptop or other computer.

If the computer you will use does not have a serial port, you will need to use the Serial to USB adapter. Be sure to install the drivers for your adapter.

Step 2 Start your terminal software.

Step 3 Configure the terminal software as follows:

- The COM port for the connection you are about to establish is the connection to the fabric interconnect. You may need to look in the computer's device manager to confirm this.
- The other connection parameters are 9600 baud, 8 data bits, no parity, 1 stop bit.

Step 4 Use the terminal software's command to open the connection to the fabric interconnect.

A session window will start and you will see one of the following prompts:

```
loader>
or
switch(boot) #
or
FI-A(local-mgmt) #
```

You now have terminal access. Depending on the prompt, you may have all Cisco UCS Manager CLI commands or a very abbreviated set of configuration commands.

Connecting the Management Port



Caution To prevent an IP address conflict, do not connect the management port to the network until the initial configuration is complete. For configuration instructions, see the *Configuration Guide* for the version of Cisco UCS Manager that you are using. The configuration guides are available at this URL: <http://www.cisco.com/c/en/us/support/servers-unified-computing/ucs-manager/products-installation-and-configuration-guides-list.html>

The Ethernet management connector port has an RJ-45 interface that will connect to an external hub, switch, or router.

Procedure

-
- Step 1** Connect the appropriate modular cable to the Ethernet management connector port:
- Use modular, RJ-45, straight-through UTP cables to connect the port to an Ethernet switch or hub.
 - Use a cross-over cable to connect to a router interface.
- Step 2** Connect the other end of the cable to the device.
-

Connecting to an SFP+ Ethernet or Fibre Channel Port

Installing or Removing SFP Transceivers



Caution Excessively removing and installing an SFP transceiver can shorten its life. Do not remove and install transceivers more often than necessary. We recommend that you disconnect cables before installing or removing SFP transceivers to prevent damage to the cable or transceiver.

Use an SFP transceiver to connect to a Fibre Channel port.

Installing a Transceiver

Use an SFP+ transceiver to connect to an Ethernet or Fibre Channel port.

Procedure

- Step 1** Attach an ESD wrist strap and follow the instructions for its use.
- Step 2** Remove the dust cover from the port cage.
- Step 3** Remove the dust cover from the port end of the transceiver.
- Step 4** Insert the transceiver into the port:
- If the transceiver has a Mylar tab, position the transceiver with the tab on the bottom, and then gently insert the transceiver into the port until it clicks into place.
 - If the transceiver has a bale clasp, position the transceiver with the clasp on the bottom, close the clasp by pushing it up over the transceiver, and then gently insert the transceiver into the port until it clicks into place.
 - If the transceiver does not install easily, ensure that it is correctly positioned and the tab or clasp are in the correct position before continuing.

Note If you cannot install the cable into the transceiver, insert or leave the dust plug in the cable end of the transceiver.

Removing a Transceiver

Use an SFP+ transceiver to connect to an Ethernet or Fibre Channel port.



Caution Excessively installing and removing an SFP or SFP+ transceiver can shorten its life. Do not remove and install transceivers unless it is absolutely necessary. We recommend disconnecting cables before installing or removing transceivers to prevent damage to the cable or transceiver.

Procedure

- Step 1** Attach an ESD wrist strap and follow the instructions for its use.
- Step 2** If a cable is installed in the transceiver:
- a) Record the cable and port connections for later reference.
 - b) Press the release latch on the cable, grasp the connector near the connection point, and gently pull the connector from the transceiver.
 - c) Insert a dust plug into the cable end of the transceiver.
- If the transceiver does not remove easily in the next step, push the transceiver completely in and then ensure that the latch is in the correct position before continuing.

Step 3 Remove the transceiver from the port:

- If the transceiver has a Mylar tab latch, gently pull the tab straight out (do not twist), and then pull the transceiver out of the port.
- If the transceiver has a bale clasp latch, open the clasp by pressing it downwards, and then pull the transceiver out of the port.

Note If you cannot remove the SFP+ transceiver, reseal it by returning the bale clasp to the up position. Press the SFP+ transceiver inward and upward into the cage. Next, lower the bale clasp and pull the SFP+ transceiver straight out with a slight upward lifting force. Be careful not to damage the port cage during this process.

Step 4 Insert a dust cover into the port end of the transceiver and place the transceiver on an antistatic mat or into a static shielding bag if you plan to return it to the factory.

Step 5 If another transceiver is not being installed, protect the optical cage by inserting a clean cover.

Installing or Removing Cables into SFP or SFP+ Transceivers

Installing a Cable into a Transceiver



Caution To prevent damage to the copper cables, do not place more tension on them than the rated limit and do not bend to a radius of less than 1 inch if there is no tension in the cable, or 2 inches if there is tension in the cable.



Caution To prevent possible damage to the cable or transceiver, install the transceiver in the port before installing the cable in the transceiver.

Procedure

Step 1 Attach an ESD wrist strap and follow its instructions for use.

Step 2 Remove the dust cover from the connector on the cable.

Step 3 Remove the dust cover from the cable end of the transceiver.

Step 4 Align the cable connector with the transceiver and insert the connector into the transceiver until it clicks into place.

If the cable does not install easily, ensure that it is correctly positioned before continuing.

For instructions on verifying connectivity, see the *Configuration Guide* for the version of Cisco UCS Manager that you are using. The configuration guides are available at this URL: <http://www.cisco.com/c/en/us/support/servers-unified-computing/ucs-manager/products-installation-and-configuration-guides-list.htm>.

Removing a Cable from a Transceiver



Caution To prevent damage to the copper cables, do not place more tension on them than the rated limit and do not bend to a radius of less than 1 inch if there is no tension in the cable, or 2 inches if there is tension in the cable.



Caution When pulling a cable from a transceiver, grip the body of the connector. Do not pull on the jacket sleeve, because this action can compromise the fiber-optic termination in the connector.



Caution If the cable cannot be easily removed, ensure that any latch present on the cable has been released before continuing.

Procedure

- Step 1** Attach an ESD wrist strap and follow the instructions for its use.
- Step 2** Press the release latch on the cable, grasp the connector near the connection point, and gently pull the connector from the transceiver.
- Step 3** Insert a dust plug into the cable end of the transceiver.
- Step 4** Insert a dust plug onto the end of the cable.

Connecting to a Fibre Channel Port

Installing or Removing SFP+ Transceivers

Installing an SFP Transceiver



Caution Excessively removing and installing an SFP transceiver can shorten its life. Do not remove and install transceivers more often than necessary. We recommend that you disconnect cables before installing or removing SFP transceivers to prevent damage to the cable or transceiver.

Procedure

- Step 1** Attach an ESD wrist strap and follow the instructions for its use.
- Step 2** Remove the dust cover from the port cage.
- Step 3** Remove the dust cover from the port end of the transceiver.

Step 4 Insert the transceiver into the port:

- If the transceiver has a Mylar tab, position the transceiver with the tab on the bottom, and then gently insert the transceiver into the port until it clicks into place.
- If the transceiver has a bale clasp, position the transceiver with the clasp on the bottom, close the clasp by pushing it up over the transceiver, and then gently insert the transceiver into the port until it clicks into place.



Caution If the transceiver does not install easily, ensure that it is correctly positioned and the tab or clasp are in the correct position before continuing.



Note If you cannot install the cable into the transceiver, insert or leave the dust plug in the cable end of the transceiver.

Removing an SFP Transceiver

Procedure

Step 1 Attach an ESD wrist strap and follow the instructions for its use.

Step 2 If a cable is installed in the transceiver, do the following:

- a) Record the cable and port connections for later reference.
- b) Press the release latch on the cable, grasp the connector near the connection point, and gently pull the connector from the transceiver.
- c) Insert a dust plug into the cable end of the transceiver.

Step 3 Remove the transceiver from the port:

- If the transceiver has a Mylar tab latch, gently pull the tab straight out (do not twist), and then pull the transceiver out of the port.
- If the transceiver has a bale clasp latch, open the clasp by pressing it downwards, and then pull the transceiver out of the port.

Note If you have difficulty removing a bale clasp SFP transceiver, reseal the SFP by returning the bale clasp to the up position. Press the SFP inward and upward into the cage. Next, lower the bale clasp and pull the SFP straight out with a slight upward lifting force. Be careful not to damage the port cage during this process.

Step 4 Insert a dust cover into the port end of the transceiver and place the transceiver on an antistatic mat or into a static-shielding bag if you plan to return it to the factory.

Step 5 If another transceiver is not being installed, protect the optical cage by inserting a clean cover.

Installing or Removing Cables into SFP Transceivers



Caution To prevent damage to the fiber-optic cables, do not place more tension on them than the rated limit and do not bend to a radius of less than 1 inch if there is no tension in the cable, or 2 inches if there is tension in the cable.

Installing a Cable into an SFP Transceiver



Caution To prevent possible damage to the cable or transceiver, install the transceiver in the port before installing the cable in the transceiver.

Procedure

- Step 1** Attach an ESD wrist strap and follow the instructions for its use.
- Step 2** Remove the dust cover from the connector on the cable.
- Step 3** Remove the dust cover from the cable end of the transceiver.
- Step 4** Align the cable connector with the transceiver and insert the connector into the transceiver until it clicks into place.

If the cable does not install easily, ensure that it is correctly positioned before continuing.

For instructions on verifying connectivity, see the *Configuration Guide* for the version of Cisco UCS Manager that you are using. The configuration guides are available at this URL: <http://www.cisco.com/c/en/us/support/servers-unified-computing/ucs-manager/products-installation-and-configuration-guides-list.html>

Removing a Cable from an SFP Transceiver



Caution When pulling a cable from a transceiver, grip the body of the connector. Do not pull on the jacket sleeve, because this action can compromise the fiber-optic termination in the connector.



Caution If the cable cannot be easily removed, ensure that any latch present on the cable has been released before continuing.

Procedure

- Step 1** Attach an ESD wrist strap and follow the instructions for its use.

- Step 2** Press the release latch on the cable, grasp the connector near the connection point, and gently pull the connector from the transceiver.
- Step 3** Insert a dust plug into the cable end of the transceiver.
- Step 4** Insert a dust plug onto the end of the cable.
-

Maintaining SFP28 Transceivers and Fiber-Optic Cables

SFP28, SFP+ transceivers, and fiber-optic cables must be kept clean and dust-free to maintain high signal accuracy and prevent damage to the connectors. Attenuation (loss of light) is increased by contamination and should be kept below 0.35 dB.

Consider the following maintenance guidelines:

- Transceivers are static sensitive. To prevent ESD damage, wear an ESD wrist strap that is connected to the chassis.
- Do not remove and insert a transceiver more often than is necessary. Repeated removals and installation can shorten its useful life.
- Keep all optical connections covered when not in use. If they become dusty, clean before using to prevent dust from scratching the fiber-optic cable ends.
- Do not touch ends of connectors, ensuring that they remain free of fingerprints and other contamination.
- Clean regularly; the required frequency of cleaning depends upon the environment. In addition, clean connectors if they are exposed to dust or are accidentally touched. Both wet and dry cleaning techniques can be effective. Refer to fiber-optic cleaning procedures for your site.
- Inspect routinely for dust and damage. If damage is suspected, clean and then inspect fiber ends under a microscope to determine if damage has occurred.



APPENDIX **A**

Technical Specifications

- [System Specifications, on page 55](#)
- [Power Specifications, on page 56](#)
- [Transceiver Specifications, on page 57](#)

System Specifications

Table 9: Physical Specifications

Description	Specification
Physical (Cisco UCS 6332)	
Dimensions (H x W x D)	1.72 in. x 17.3 in. x 22.5 in. (4.4 cm x 43.94 cm x 57.1 cm)
Weight (with two power supplies installed)	22 lb (9.97 kg)
Physical (Cisco UCS 6332-16UP)	
Dimensions (H x W x D)	1.72 in. x 17.3 in. x 22.5 in. (4.4 cm x 43.94 cm x 57.1 cm)
Weight (with two power supplies installed)	22.61 lb (10.25 kg)
Environmental	
Temperature, operating	32 to 104°F (0 to 40°C)
Temperature, nonoperating	-40 to 158°F (-40 to 70°C)
Humidity (RH), noncondensing	5 to 95%
Altitude	0 to 10000 ft (0 to 3000 m)

Power Specifications

Cisco UCS 6300 Fabric Interconnects support AC, DC, or HVDC power supplies. You must use identical power supplies—either two AC, two DC, or two HVDC power supplies— with the fabric interconnect. In addition, if you use DC or HVDC power supplies, you must use two corresponding DC or HVDC power cords.



Note You cannot mix power supply types in a Cisco 6300 Series Fabric Interconnect.

Table 10: Specifications for the Cisco UCS 6300 Series AC Power Supply(UCS-PSU-6332-AC)

AC Power Supply Properties	Cisco UCS 6300 Series Fabric Interconnect
Maximum output per power supply	650 W
Input voltage	100 to 240 VAC
Maximum AC input current	7.6 A @ 100 VAC 3.65 A @ 208 VAC
Maximum holdup time	12 ms @50% load
Power supply output voltage	12 VDC
Power supply standby voltage	12 VDC
RoHS compliance	Yes
Hot swappable	Yes
Efficiency rating	Climate Savers Platinum Efficiency (80Plus Platinum Certified)

Table 11: Specifications for the Cisco UCS 6300 Series DC Power Supply (UCS-PSU-6332-DC)

DC Power Supply Properties	Cisco UCS 6300 Series Fabric Interconnect
Maximum output per power supply	930 W
Input voltage	-48 VDC
Maximum HVDC input current	23 A maximum @ -48 VDC
Maximum holdup time	8 ms @ 50% load
Power supply output voltage	12 VDC
Power supply standby voltage	12 VDC
RoHS compliance	Yes

DC Power Supply Properties	Cisco UCS 6300 Series Fabric Interconnect
Hot swappable	Yes
Efficiency rating	Climate Savers Platinum Efficiency (80Plus Platinum Certified)

Table 12: Specifications for the Cisco UCS 6300 Series HVDC Power Supply (N9K-PUV-1200W)

HVDC Power Supply Properties	Cisco UCS 6300 Series Fabric Interconnect
Maximum output per power supply	1230 W
Input voltage	240 to 380 VDC
Maximum HVDC input current	6 A
Power supply output voltage	12 VDC
Power supply standby voltage	12 VDC
RoHS compliance	Yes
Hot swappable	Yes
Efficiency rating	Climate Savers Platinum Efficiency (80Plus Platinum Certified)

Transceiver Specifications

Table 13: General Specifications for the 10-Gigabit Ethernet SFP+ Transceiver Module

Description	Short Range	
Connector type	LC	
Wavelength	850 nm	
Core size—Cable distance	50 microns—300 m	62.5 microns—33 m

Environmental Conditions and Power Requirements Specification for SFP Transceivers

Table 14: Environmental Conditions and Power Requirements Specifications for SFP Transceivers

Parameter	Symbol	Minimum	Maximum
Storage temperature ¹	TS	-40°C (-40°F)	85°C (185°F)

Parameter	Symbol	Minimum	Maximum
Case temperature ²	TC	0°C (32°F)	70°C (158°F)
Relative humidity ²	RH	5%	95%
Module supply voltage ²	VCCT,R	3.1 V	3.5 V

¹ Absolute maximum ratings are those values beyond which damage to the device may occur if these limits are exceeded for other than a short period of time.

² Functional performance is not intended, device reliability is not implied, and damage to the device may occur over an extended period of time between absolute maximum ratings and the recommended operating conditions.

General Specifications for Cisco Fibre Channel SFP Transceivers

The table below lists the general specifications for Cisco Fibre Channel SFP transceivers at 4 Gbps.

Table 15: General Specifications for Cisco Fibre Channel SFP Transceivers at 4 Gbps

Description	Short Wavelength	
Connector type	LC	
Wavelength	850 nm	
Fibre type	MMF	
Core size—Cable distance	50 microns—328.08 yd (300 m)	62.5 microns—164.04 yd (150 m)
Transmit power	-9 to -2.5 dBm	

³ Approximate; actual distance may vary depending on fiber quality and other factors.

Environmental Conditions and Power Requirements Specification for SFP Transceivers

Table 16: Environmental Conditions and Power Requirements Specifications for SFP Transceivers

Parameter	Symbol	Minimum	Maximum
Storage temperature ⁴	TS	-40°C (-40°F)	85°C (185°F)
Case temperature ²	TC	0°C (32°F)	70°C (158°F)
Relative humidity ²	RH	5%	95%
Module supply voltage ²	VCCT,R	3.1 V	3.5 V

⁴ Absolute maximum ratings are those values beyond which damage to the device may occur if these limits are exceeded for other than a short period of time.

- ⁵ Functional performance is not intended, device reliability is not implied, and damage to the device may occur over an extended period of time between absolute maximum ratings and the recommended operating conditions.



APPENDIX **B**

Cable and Port Specifications

- [Accessory Kit for the Cisco UCS Fabric Interconnect, on page 61](#)
- [Console Cable, on page 62](#)
- [Console Port, on page 62](#)
- [Supported AC Power Cords and Plugs, on page 63](#)

Accessory Kit for the Cisco UCS Fabric Interconnect

The Cisco UCS Fabric Interconnect accessory kit includes the following items:

- 2 slider rails
- 2 rack-mount guides
- 2 rack-mount brackets
- 12 M4 x 0.7 x 8-mm Phillips countersunk screws
- 10 10-32 rack nuts
- 10 10-32 x 3/4-inch Phillips pan-head screws
- 1 console cable with an RJ-45-RS-232 adapter and a DB9 adapter
- 1 ground lug kit
- 1 ESD wrist strap
- 1 power cord clip (a wire clip that is used to retain the power cord)
- 1 pointer document (specifies where to find the online product documentation)



Note Additional parts can be ordered from your customer service representative.

Console Cable

The console cable has an RJ-45 connector on one end and a DB9 connector on the other; this cable is used to connect into the RS-232 console connection on a laptop.

Console Cable

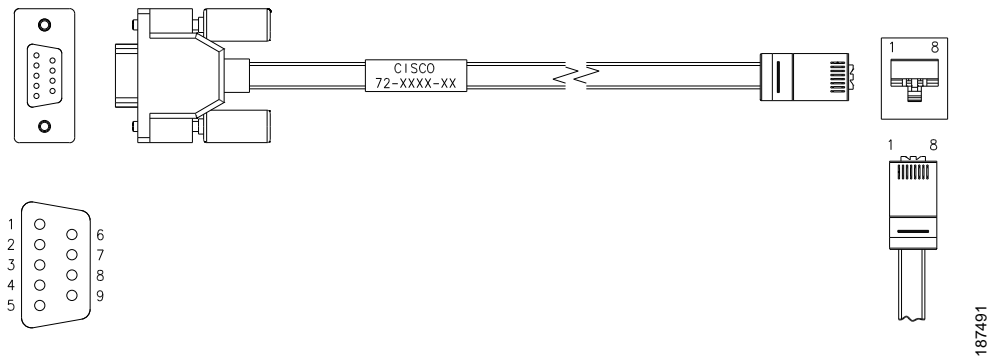

Table 17: Console Cable Connector Pinouts

Signal Name	P1, P1-45 Pins	P2, DB-9 Pins	Signal Name
RTS	1	8	CTS
DTR	2	6	DSR
TXD	3	2	ZXD
GND	4	5	GND
GND	5	5	GND
ZXD	6	3	TXD
DSR	7	4	DTR
CTS	8	7	RTS

Console Port

The console port is an asynchronous RS-232 serial port with an RJ-45 connector.

The table below lists the pinouts for the console port on the Cisco UCS 6454 Fabric Interconnect.

Table 18: Console Port Pinouts

Pin	Signal
1	RTS

Pin	Signal
2	DTR
3	TxD
4	GND
5	GND
6	RxD
7	DSR
8	CTS

Depending on the laptop you use for the initial configuration, you may also want a USB 2.0 to Serial (9-pin) DB-9 RS-232 Adapter Cable as well as a terminal program like Hyperterminal or PuTTY (set to connect at 9600 baud, 8 data bits, 1 stop bit, no parity).

Supported AC Power Cords and Plugs

Each power supply has a separate power cord. Standard power cords or jumper power cords are available for connection to a power distribution unit having IEC 60320 C13 outlet receptacles. The jumper power cords, for use in cabinets, are available as an optional alternative to the standard power cords.

The standard power cords have an IEC C13 connector on the end that plugs into the power supplies. The optional jumper power cords have an IEC C13 connector on the end that plugs into the power supplies, and an IEC C14 connector on the end that plugs into an IEC C13 outlet receptacle.



Note Only the regular power cords or jumper power cords provided with the chassis are supported.

Argentina

Power Cord—SFS-250V-10A-AR

Plug—250 VAC 10 A IRAM 2073

Length—8.2 feet / 2.5 meters

Figure 16: SFS-250V-10A-AR

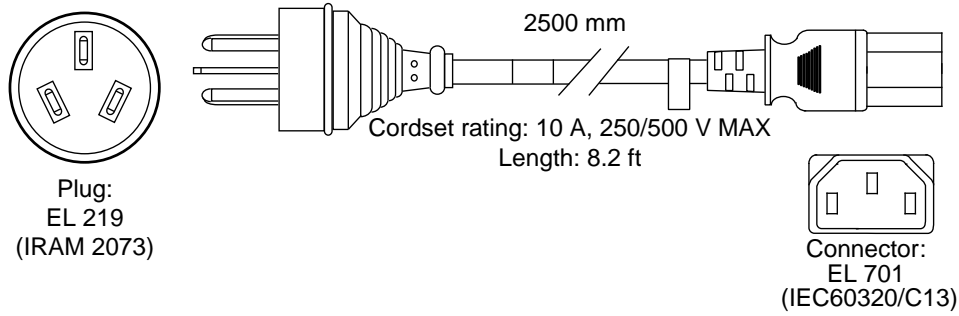

186571

Australia and New Zealand

Power Cord—CAB-9K10A-AU

Plug—250 VAC 10 A 3112

Length—8.2 feet / 2.5 meters

Figure 17: CAB-9K10A-AU

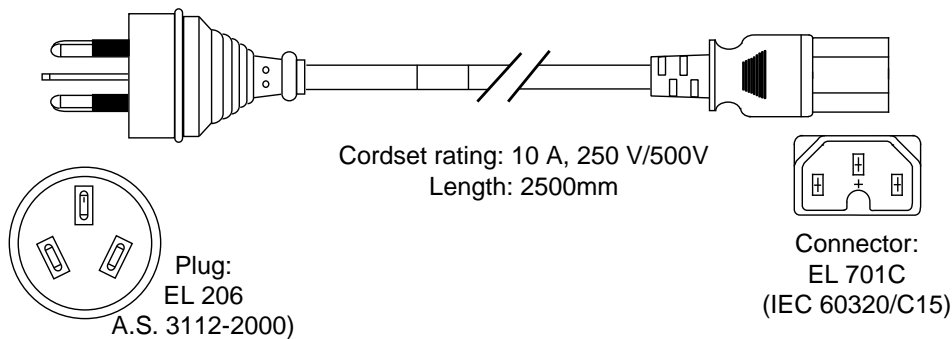

186581

Peoples Republic of China

Power Cord—SFS-250V-10A-CN

Plug—250 VAC 10 A GB 2009

Length—8.2 feet / 2.5 meters

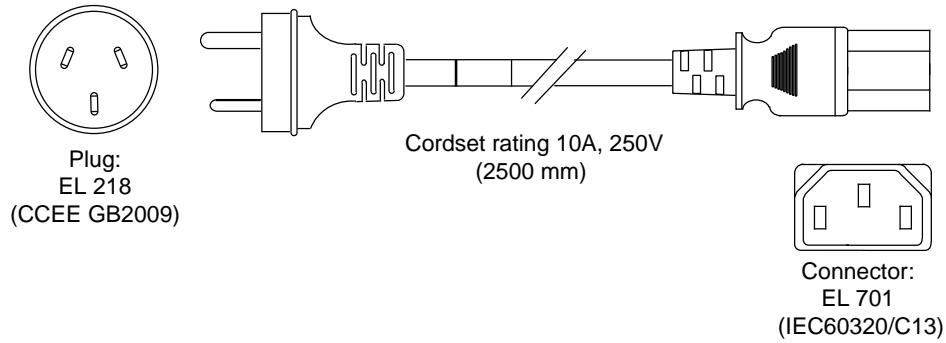
Figure 18: SFS-250V-10A-CN

186573

Taiwan

Power Cord—CAB-AC-C19-TW

Plug—250 VAC 16 A, C19

Length—7.5 feet / 2.3 meters

Europe

Power Cord—CAB-9K10A-EU

Plug—250 VAC 10 A M 2511

Length—8.2 feet / 2.5 meters

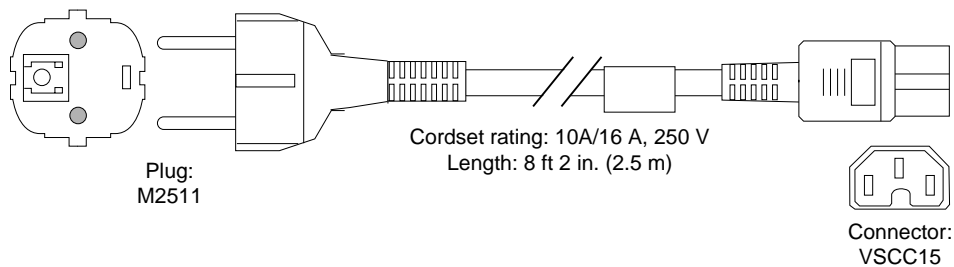
Figure 19: CAB-9K10A-EU

186576

India, South Africa, and United Arab Emirates

Power Cord—SFS-250V-10A-ID

Plug—250 VAC 16A EL-208

Length—8.2 feet / 2.5 meters

Figure 20: SFS-250V-10A-ID

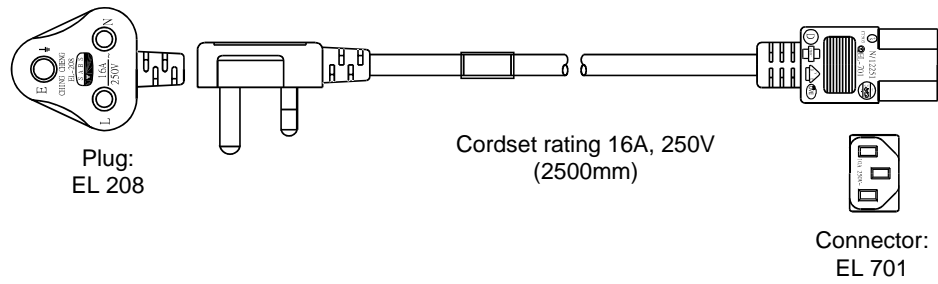

187490

Israel

Power Cord—SFS-250V-10A-IS

Plug—250 VAC 10 A SI32

Length—8.2 feet / 2.5 meters

Figure 21: SFS-250V-10A-IS

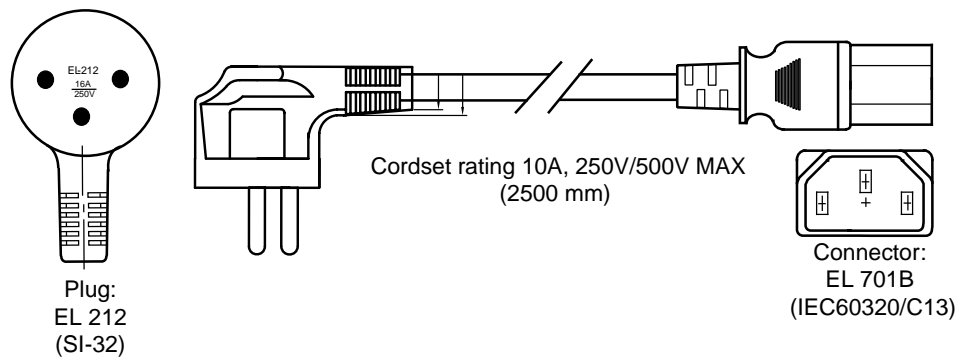

186574

Italy

Power Cord—CAB-9K10A-IT

Plug—250 VAC 10 A CEI 23-16

Length—8.2 feet / 2.5 meters

Figure 22: CAB-9K10A-IT

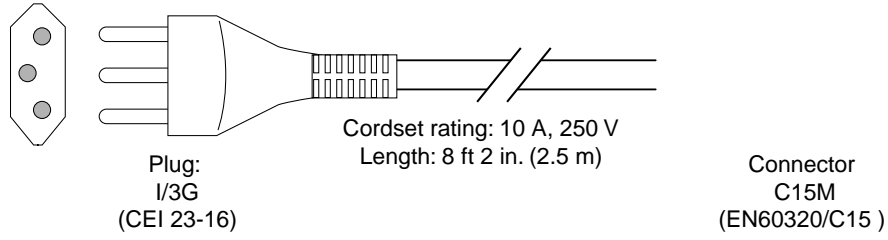

186575

North America

CAB-AC-250V/13A

Power Cord—CAB-AC-250V/13A

Plug—250 VAC 13 A IEC60320

Length—6.6 feet / 2.0 meters

Figure 23: CAB-AC-250V/13A

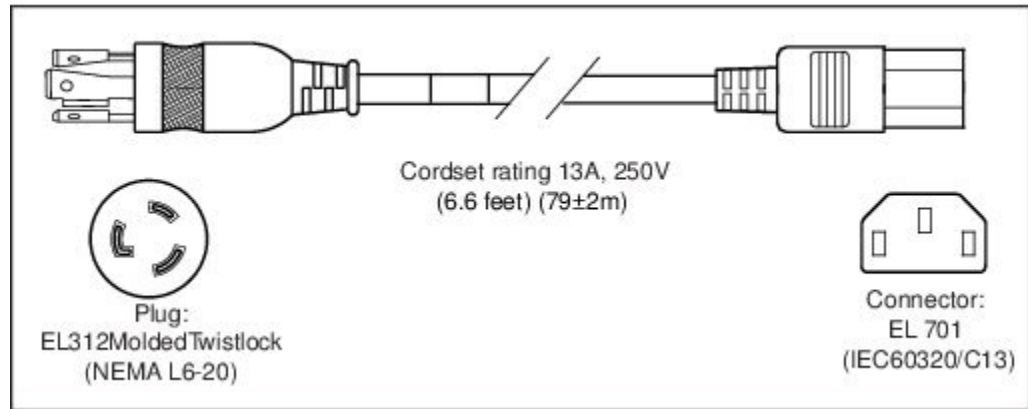

186568

CAB-N5K6A-NA

Power Cord—CAB-N5K6A-NA

Plug—250 VAC 13 A NEMA 6-15

Length—8.2 feet / 2.5 meters

Figure 24: CAB-N5K6A-NA

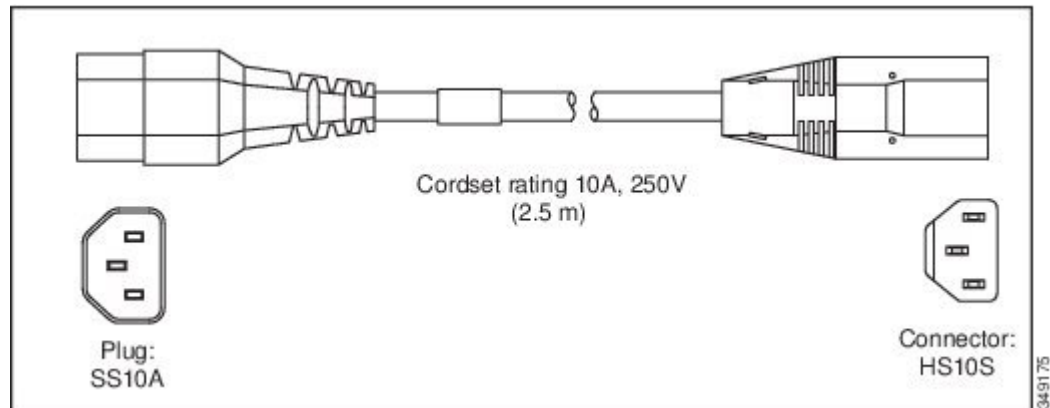

Switzerland

Power Cord—CAB-9K10A-SW

Plug—250 VAC 10 A MP232

Length—8.2 feet / 2.5 meters

Figure 25: CAB-9K10A-SW

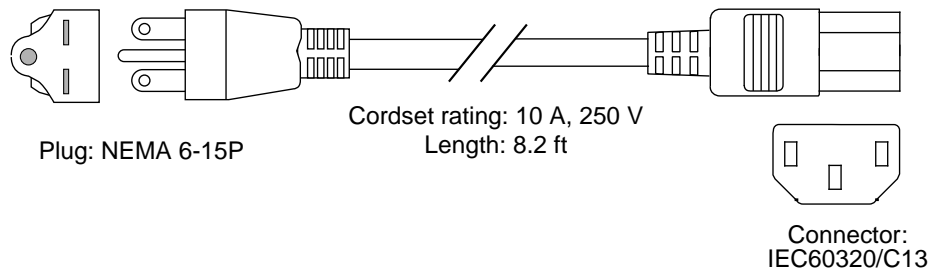

United Kingdom

Power Cord—CAB-9K10A-UK

Plug—250 VAC 10 A BS1363 (13 A fuse)

Length—8.2 feet / 2.5 meters

Figure 26: CAB-9K10A-UK

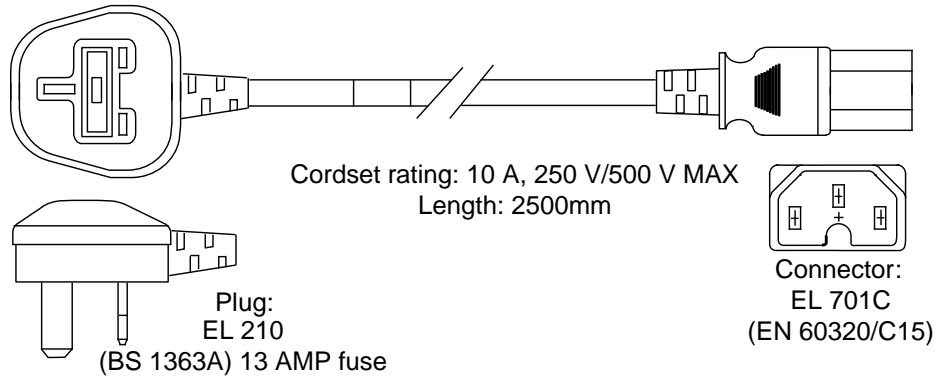

1866580

Cabinet Jumper Power Cords

Jumper Power Cord—CAB-C13-C14-JMPR

Plug— 250 VAC 10 A, C13-C14 Connectors

Length—2.2 feet / 0.7 meters

Figure 27: CAB-C13-C14-JMPR

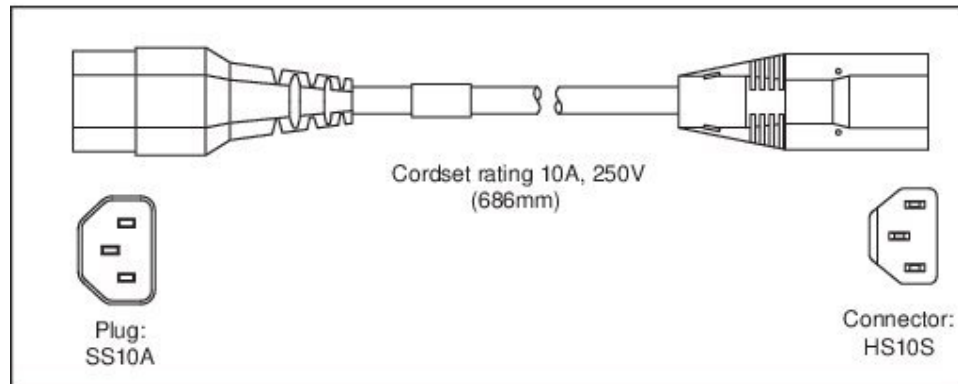

1866589

Jumper Power Cord—CAB-C13-C14-AC

Plug— 250 VAC 10 A, C13-C14 Connectors

Length—9.8 feet / 3 meters

Figure 28: CAB-C13-C14-AC

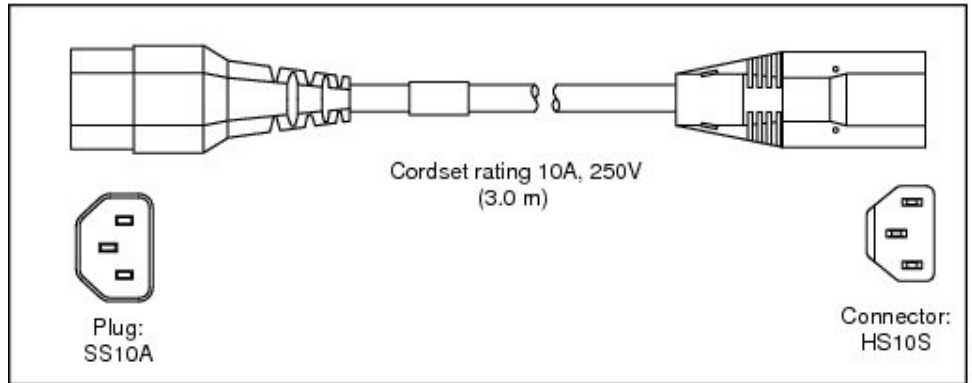

Jumper Power Cord—CAB-C13-C14-2M

Plug—250 VAC 10 A, C13-C14 Connectors

Length—6.6 feet / 2 meters

Figure 29: CAB-C13-C14-2M

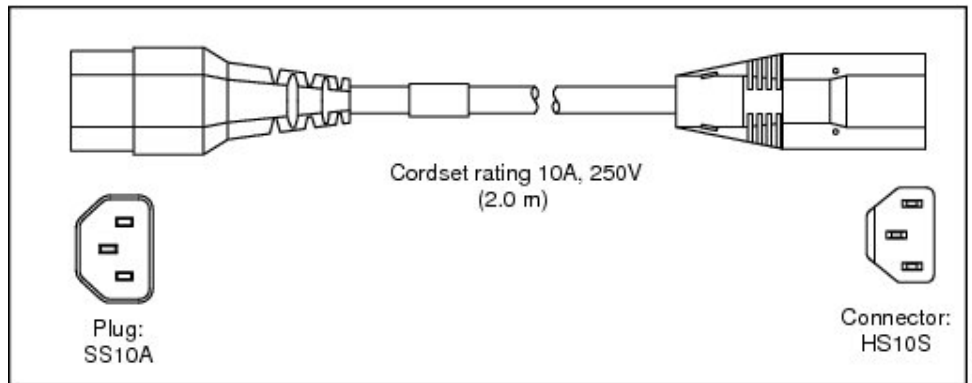



APPENDIX **C**

Site Planning and Maintenance Records

- [Site Preparation Checklist, on page 71](#)
- [Contact and Site Information, on page 73](#)
- [Chassis and Module Information, on page 74](#)

Site Preparation Checklist

Planning the location and layout of your equipment is essential for successful system operation, ventilation, and accessibility.

Consider heat dissipation when sizing the air-conditioning requirements for an installation.

Table 19: Site Planning Checklist

Task No.	Planning Activity	Verified By	Time	Date
1	Space evaluation: <ul style="list-style-type: none">• Space and layout• Floor covering• Impact and vibration• Lighting• Maintenance access			

Task No.	Planning Activity	Verified By	Time	Date
2	Environmental evaluation: <ul style="list-style-type: none"> • Ambient temperature • Humidity • Altitude • Atmospheric contamination • Air flow 			
3	Power evaluation: <ul style="list-style-type: none"> • Input power type • Power receptacles • Receptacle proximity to the equipment • Dedicated circuit for power supply • Dedicated (separate) circuits for redundant power supplies • UPS for power failures 			
4	Grounding evaluation: <ul style="list-style-type: none"> • Circuit breaker size • CO ground (AC- powered systems) 			

Task No.	Planning Activity	Verified By	Time	Date
5	Cable and interface equipment evaluation: <ul style="list-style-type: none"> • Cable type • Connector type • Cable distance limitations • Interface equipment (transceivers) 			
6	EMI evaluation: <ul style="list-style-type: none"> • Distance limitations for signaling • Site wiring • RFI levels 			

⁶ Verify that the power supply installed in the chassis has a dedicated AC source circuit.

⁷ UPS = uninterruptible power supply.

⁸ EMI = electromagnetic interference.

⁹ RFI = radio frequency interference.

Contact and Site Information

Use the following worksheet to record contact and site information.

Table 20: Contact and Site Information

Contact person	
Contact phone	
Contact e-mail	
Building/site name	
Data center location	
Floor location	
Address (line 1)	
Address (line 2)	

City	
State	
Zip code	
Country	

Chassis and Module Information

Use the following worksheets to record information about the chassis and modules.

Contract Number _____

Chassis Serial Number _____

Product Number _____

Table 21: Network-Related Information

System IP address	
System IP netmask	
Hostname	
Domain name	
IP broadcast address	
Gateway/router address	
DNS address	
Modem telephone number	

Table 22: Module Information

Slot	Module Type	Module Serial Number	Notes
1	Fixed		
2	Expansion		

Table 23: Fabric Interconnect Port Connection Record

Fabric Interconnect A or B		Connected to					
Slot	Port	Chassis	FEX	Port	LAN or SAN Pin Group	Port Channel Group	Connection Notes
1	1						
	2						
	3						
	4						
	5						
	6						
	7						
	8						
	9						
	10						
	11						
	12						
	13						
	14						
	15						
	16						
	17						
	18						
	19						
	20						
	21						
	22						
	23						
	24						
	25						

Fabric Interconnect A or B		Connected to					
Slot	Port	Chassis	FEX	Port	LAN or SAN Pin Group	Port Channel Group	Connection Notes
	26						
	27						
	28						
	29						
	30						
	31						
	32						
2	1						
	2						
	3						
	4						
	5						
	6						
	7						
	8						
	9						
	10						
	11						
	12						
	13						
	14						
	15						
	16						



APPENDIX **D**

Troubleshooting Hardware Components

- [Overview, on page 77](#)
- [SNMP Traps, on page 77](#)
- [Server Port Link State Transitions, on page 77](#)
- [System Hardware Best Practices, on page 78](#)

Overview

A Cisco UCS 6300 Series Fabric Interconnect provides network connectivity and management capabilities for the UCS system. The UCS 6300 Series Fabric Interconnect supports the management of power supplies, fans, and blade servers in the UCS 5108 Server Chassis. When connected to the UCS 2304 I/O module, a UCS 6300 Series Fabric Interconnect provides an end-to-end 40-Gigabit Ethernet and 16-Gigabit Fibre Channel architecture.

- The UCS 6332 Fabric Interconnect is a 1 rack unit (RU) is 32-port Ethernet or FCoE chassis that provides 40-Gigabit Ethernet switching.
- The UCS 6332-16UP Fabric Interconnect is a 1 RU chassis that supports Ethernet, FCoE, and and Fibre Channel. It has 16 Fibre Channel ports and 24 40-Gigabit QSFP+ ports.

SNMP Traps

You can set SNMP traps to monitor fans, power supplies, and temperature settings, or to test a call home application. For details, see the *Configuration Guide* for the version of Cisco UCS Manager that you are using. The configuration guides are available at the following URL:
http://www.cisco.com/en/US/products/ps10281/products_installation_and_configuration_guides_list.html

Server Port Link State Transitions

When cables of server ports are removed from the Fabric Interconnect, Cisco UCS Manager displays a message indicating that the link is down because of link failure or not connected. Before the cable is plugged back in, a false "[F0276][cleared]" event might be logged after 20 to 30 seconds.

When a port that is Up gets disconnected, it transitions to a Link Down status.

- When a port has a Link Down status, it checks if an SFP is inserted.
- If an SFP is inserted, the port status remains at Link Down, and the F0276 event is not cleared. This situation occurs when the SFP cable is plugged into the Fabric Interconnect port, and the SFP at the I/O module is disconnected.

The "Link down or not connected" fault appears, and the fault is not cleared until the SFP is plugged back into the I/O module port.

- If there is no SFP detected, the port status transitions from Link Down status to SFP Not Present. This situation occurs when the SFP is plugged into the I/O module and the other end is not plugged into the Fabric Interconnect port that is configured to be the server.
- When the port status is no longer Link Down, the F0276 is cleared.

System Hardware Best Practices

Installation Best Practices

When installing the chassis, follow these best practices:

- Plan your site configuration and prepare the site before installing the chassis.
- Verify that you have the appropriate power supplies for your chassis configuration.
- Install the chassis following the rack and airflow guidelines presented in this guide.
- Verify that the chassis is adequately grounded.

Initialization Best Practices

When the initial system boot is complete, verify the following:

- Power supplies are supplying power to the system.
- Fan modules are operating normally.
- The system software boots successfully.

System Operation Best Practices

To ensure proper operation of your system, take the following actions:

- Make a copy of the running configuration to CompactFlash for a safe backup.
- Never use the **init system** CLI command unless you understand that you will lose the running and startup configuration as well as the files stored on bootflash:.