



PTP over PRP

- [PTP over PRP, on page 1](#)
- [Supported PTP Profiles and Clock Modes, on page 4](#)
- [PRP RedBox Types, on page 4](#)
- [LAN-A and LAN-B Failure Detection and Handling, on page 9](#)
- [CLI Commands for PTP over PRP, on page 9](#)
- [Feature History for PTP over PRP, on page 12](#)

PTP over PRP

Precision Time Protocol (PTP) can operate over Parallel Redundancy Protocol (PRP) on Cisco Catalyst IE9300 Rugged Series Switches. The feature is supported on IE-9320-26S2C-A and IE-9320-26S2C-E switches beginning with Cisco IOS XE Cupertino 17.9.1. It is supported on IE-9320-22S2C4X-A, and IE-9320-22S2C4X-E switches beginning with Cisco IOS XE Dublin 17.12.1.

PRP provides high availability through redundancy for PTP. For a description of PTP, see [Precision Time Protocol Configuration Guide, Cisco Catalyst IE9300 Rugged Series Switches](#) on Cisco.com.

The PRP method of achieving redundancy by parallel transmission over two independent paths does not work for PTP as it does for other traffic. The delay that a frame experiences is not the same in the two LANs, and some frames are modified in the transparent clocks (TCs) while transiting through the LAN. A Dually Attached Node (DAN) does not receive the same PTP message from both ports even when the source is the same. Specifically:

- Sync/Follow_Up messages are modified by TCs to adjust the correction field.
- Boundary Clocks (BCs) present in the LAN are not PRP-aware and generate their own Announce and Sync frames with no Redundancy Control Trailer (RCT) appended.
- Follow_Up frames are generated by every 2-step clock and carry no RCT.
- TCs are not PRP-aware and not obliged to forward the RCT, which is a message part that comes after the payload.

Before support of PTP over LAN-A and LAN-B, PTP traffic was allowed only on LAN-A to avoid the issues with PTP and parallel transmission described earlier. However, if LAN-A went down, PTP synchronization was lost. To enable PTP to leverage the benefit of redundancy offered by the underlying PRP infrastructure, PTP packets over PRP networks are handled differently than other types of traffic.

The implementation of the PTP over PRP feature is based on the PTP over PRP operation that is detailed in IEC 62439-3:2016, *Industrial communication networks - High availability automation networks - Part 3: Parallel Redundancy Protocol (PRP) and High-availability Seamless Redundancy (HSR)*. This approach overcomes the problems mentioned earlier by not appending an RCT to PTP packets and bypassing the PRP duplicate/discard logic for PTP packets.

PTP over PRP Packet Flow

The following figure illustrates the operation of PTP over PRP.

Figure 1: PTP over PRP Packet Flow

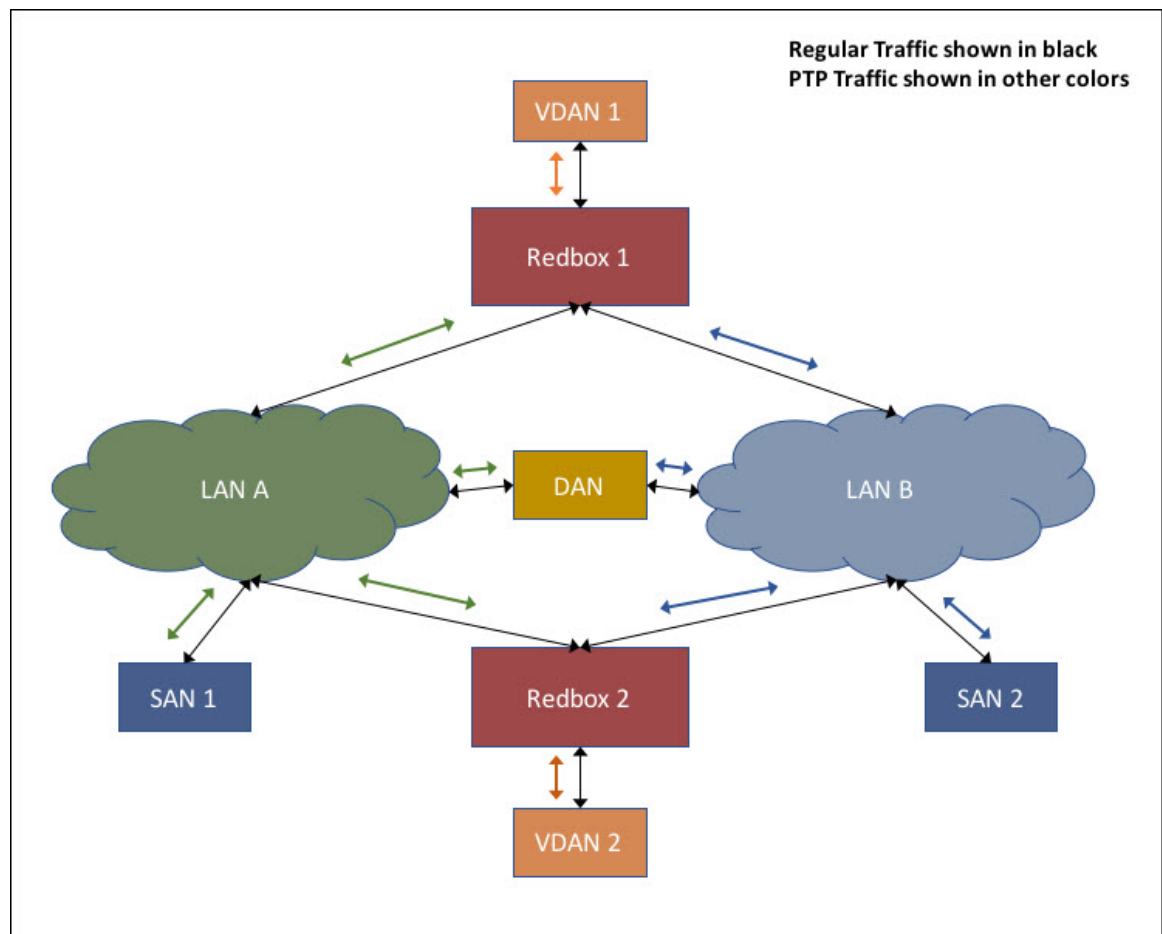

In the figure, VDAN 1 is the grandmaster clock (GMC). Dually attached devices receive PTP synchronization information over both their PRP ports. The LAN-A port and LAN-B port use a different virtual clock that is synchronized to the GMC. However, only one of the ports (referred to as time recipient) is used to synchronize the local clock (VDAN 2 in the figure). While the LAN-A port is the time recipient, the LAN-A port's virtual clock is used to synchronize VDAN-2. The other PRP port, LAN-B, is referred to as PASSIVE. The LAN-B port's virtual clock is still synchronized to the same GMC, but is not used to synchronize VDAN 2.

If LAN-A goes down, the LAN-B port takes over as the time recipient and is used to continue synchronizing the local clock on RedBox 2. VDAN 2 attached to RedBox 2 continues to receive PTP synchronization from RedBox 2 as before. Similarly, all DANs, VDANs, and RedBoxes shown in the figure continue to remain

synchronized. For SANs, redundancy is not available, and in this example, SAN 1 loses synchronization if LAN-A goes down.

Due to the change, VDAN 2 may experience an instantaneous shift in its clock due to the offset between the LAN-A port's virtual clock and the LAN-B port's virtual clock. The magnitude of the shift should only be a few microseconds at the most, because both clocks are synchronized to the same GMC. The shift also occurs when the LAN-A port comes back as time recipient and the LAN-B port becomes PASSIVE.



Note Cisco is moving from the traditional Master/Slave nomenclature. In this document, the terms Grandmaster clock (GMC) or time source and time recipient are used instead, where possible. Exceptions may be present due to language that is hard-coded in the user interfaces of the product software, language used based on RFP documentation, or language that is used by a referenced third-party product.

Supported Location of GMC

The GMC can be located in a PTP over PRP topology as one of the following:

- A RedBox that is connected to both LAN A and LAN B (for example, RedBox 1 in the preceding diagram).
- A VDAN (for example, VDAN 1 in the preceding diagram).
- A DAN (for example, the DAN in the preceding diagram).

The GMC cannot be a SAN attached to LAN-A or LAN-B, because only the devices in LAN-A or LAN-B will be synchronized to the GMC.

Configuration

PTP over PRP does not require configuration beyond how you would normally configure PTP and PRP separately, and there is no user interface added for this feature. The difference is that before the PTP over PRP feature, PTP worked over LAN-A only; now it works over both LANs. Before implementing PTP over PRP, refer to Guidelines and Limitations.

The high-level workflow to implement PTP over PRP in your network is as follows:

1. Refer to the section [PRP RedBox Types](#) in this guide to determine the location of the PRP RedBox. Refer to [Precision Time Protocol Configuration Guide, Cisco Catalyst IE9300 Rugged Series Switches](#) on Cisco.com to determine the PTP mode and profile.
2. Configure PTP as described in [Precision Time Protocol Configuration Guide, Cisco Catalyst IE9300 Rugged Series Switches](#) on Cisco.com, following the procedure for the PTP profile determined in step 1.
3. Configure PRP as described in [Create a PRP Channel and Group](#).



Note There are four PRP-capable ports on IE-9320-26S2C-A, IE-9320-26S2C-E, IE-9320-22S2C4X-A, and IE-9320-22S2C4X-E switches:

- Gi1/0/21 and Gi1/0/22 are enabled for PRP channel 1.
 - Gi1/0/23 and Gi1/0/24 are enabled for PRP channel 2.
-

Supported PTP Profiles and Clock Modes

The following table summarizes PTP over PRP support for the various PTP profiles and clock modes. In unsupported PTP profile/clock mode combinations, PTP traffic flows over LAN-A only. LAN-A is the lower numbered interface. See PRP Channels for PRP interface numbers.

PTP Profile	Clock Mode	Supported?	PRP RedBox type as per IEC 62439-3
End-to-End Delay Request-Response default profile	BC	Yes	PRP RedBox as doubly attached BC (DABC) with E2E
	E2E TC	No	PRP RedBox as doubly attached TC (DATC) with E2E
Power Profile	BC	Yes	PRP RedBox as doubly attached BC (DABC) with P2P
	P2P TC	Yes	PRP RedBox as doubly attached TC (DATC) with P2P

PRP RedBox Types

The switch plays the role of a RedBox in PRP networks. This section describes the types of PRP RedBoxes supported for PTP over PRP as defined in IEC 62439-3.

PRP RedBox as a Doubly Attached BC (DABC) with E2E

In the configuration shown below, two RedBoxes (for example, M and S) are configured as Boundary Clocks (BCs) that use the End-to-End delay measurement mechanism and IEEE1588v2 Default Profile. The Best Master Clock Algorithm (BMCA) on RedBox M determines port A and port B to be connected to the time source. The PTP protocol running on Redbox M treats both ports A and B individually as time source ports and sends out Sync and Follow_Up messages individually on both the ports.

Figure 2: PRP Redbox as DABC with E2E

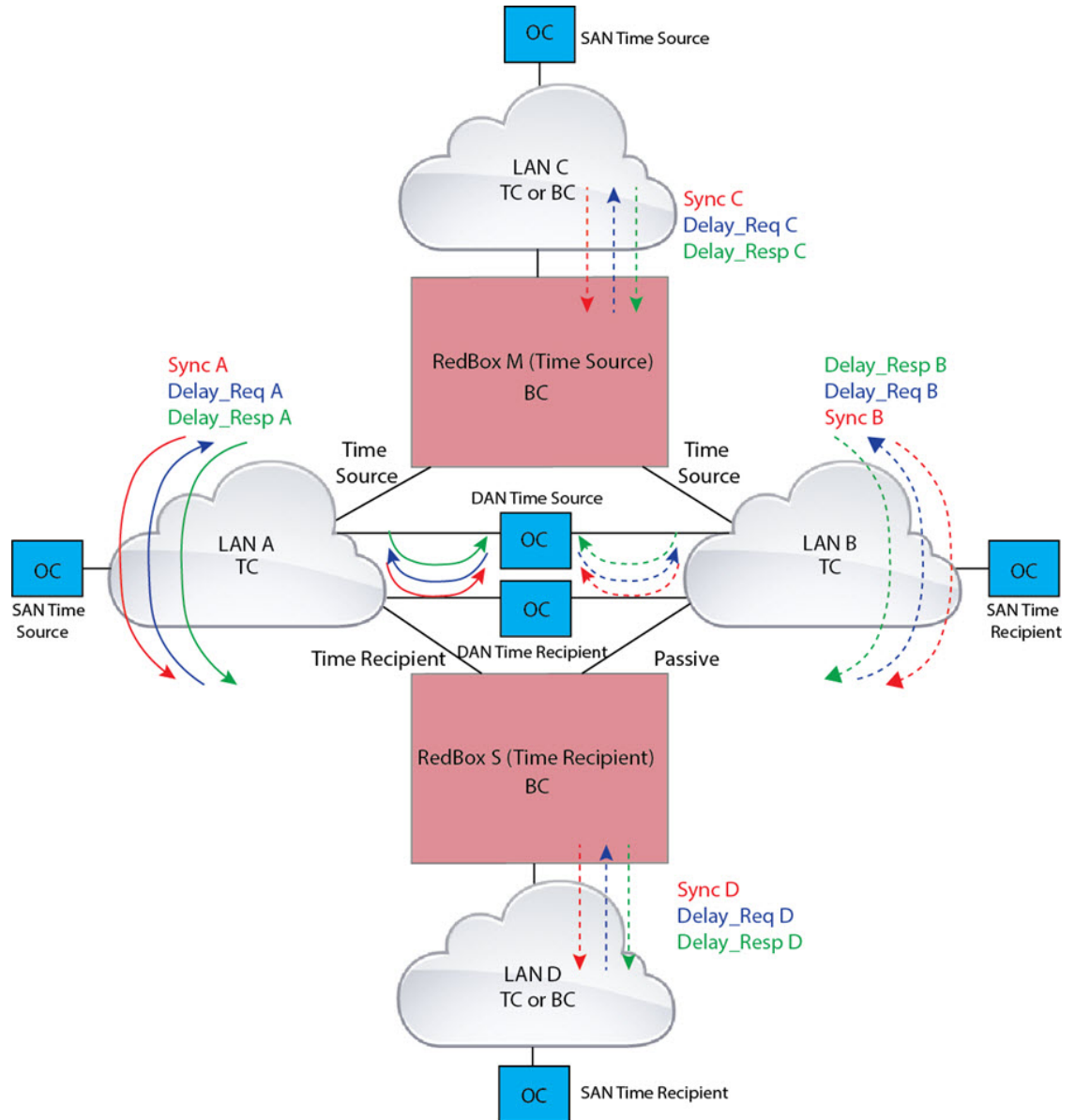

On Redbox S, the regular BMCA operation determines port A to be a time recipient and port B to be PASSIVE. However, with the knowledge that ports A and B are part of the same PRP channel, port B is forced into PASSIVE_SLAVE state. Port A and Port B on Redbox S operate as follows:

- Port A works as a regular time recipient port. It uses the end-to-end delay measurement mechanism to calculate delay and offset from the time source. Using the calculated delay and offset, it synchronizes the local clock.
- Port B is in PASSIVE_SLAVE state. It uses the end-to-end delay measurement mechanism to calculate delay and offset from the time source.

It is passive in the sense that it maintains the calculated delay and offset, but does not perform any operation on the local clock. Having the delay and offset information readily available equips it to seamlessly change its role to time recipient if there is loss of connectivity to the time source on port A.

PRP RedBox as Doubly Attached BC (DABC) with P2P

The following figure shows an example where Redbox M and Redbox S are configured to run in Power Profile as Boundary Clocks that use Peer-to-Peer (P2P) delay measurement mechanism. In this example, the GMC is the ordinary clock attached through LAN C. All the clocks are configured to run Peer-to-Peer Delay measurement and the peer delay is regularly calculated and maintained on every link shown in the figure.

The BMCA on Redbox M determines ports A and B to be connected to the time source. The PTP protocol running on Redbox M treats both ports A and B individually as time source ports and sends out Sync and Follow_Up messages individually on both the ports.

Figure 3: PRP Redbox as DABC with P2P

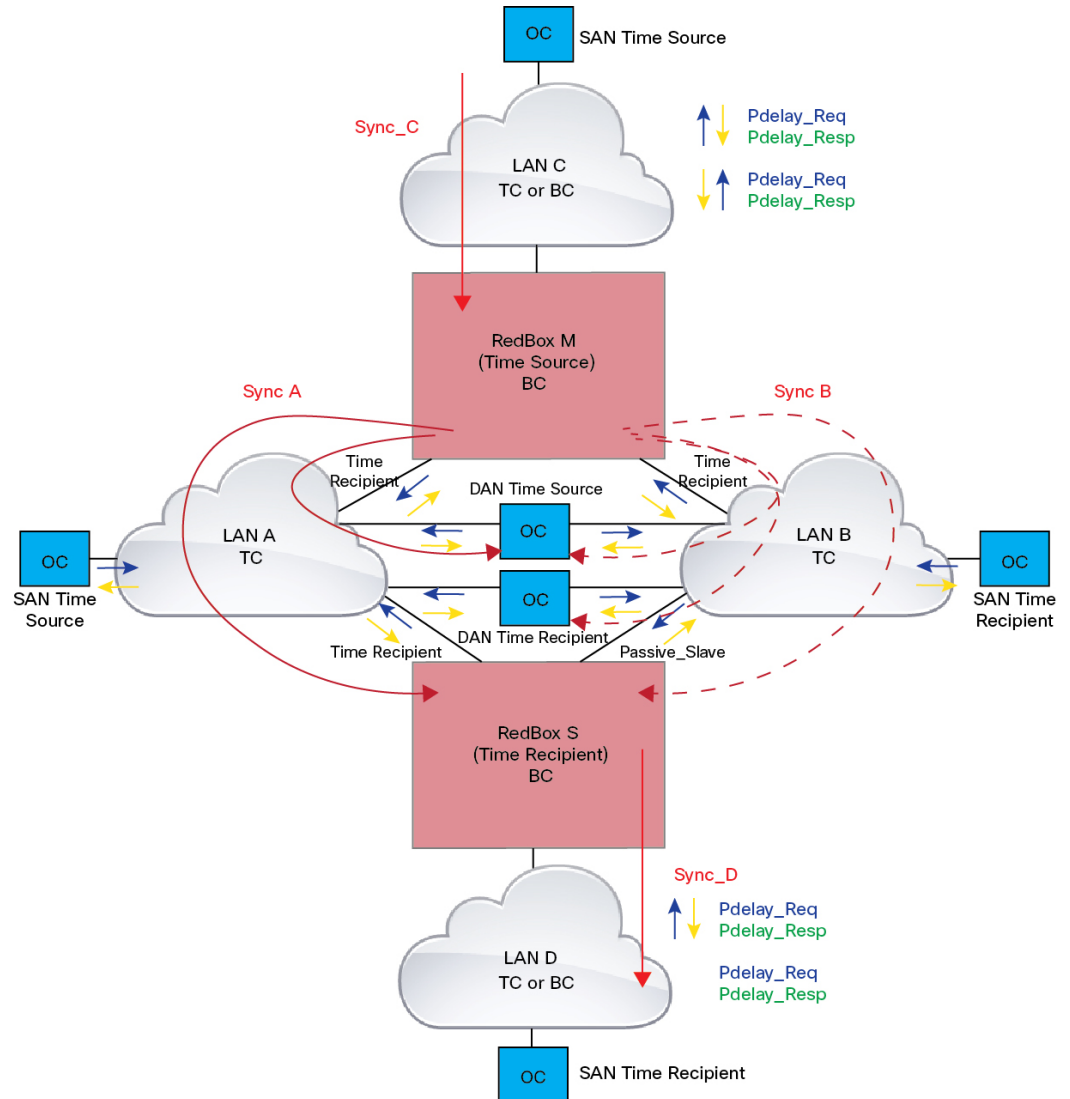

On Redbox S, the regular BMCA operation determines port A to be time recipient and port B to be PASSIVE. However, with the knowledge that ports A and B are part of the same PRP channel, port B is forced into PASSIVE_SLAVE state. Port A and Port B on Redbox S operate as follows:

- Port A works as a regular time recipient port. It uses the Sync and Follow_Up messages along with their correction field to calculate the delay and offset from time source and synchronize the local clock. (Unlike an E2E BC, it does not need to generate Delay_Req messages because all the link delays and residence times along the PTP path are accumulated in the correction field of the Follow_Up messages).
- Port B is in PASSIVE_SLAVE state. Like port A, it maintains the delay and offset from time source, but does not perform any operation on the local clock. Having all the synchronization information available enables it to seamlessly take over as the new time recipient in case port A loses communication with the GM.

PRP RedBox as Doubly Attached TC (DATC) with P2P

The following figure shows an example where Redbox M and Redbox S are configured to run in Power Profile mode as Transparent Clocks. In this example, the GMC is the ordinary clock attached through LAN C. All the clocks are configured to run Peer-to-Peer Delay measurement and the peer delay is regularly calculated and maintained on every link shown in the figure.

Redbox M and Redbox S run BMCA even though it is not mandatory for a P2P TC to run BMCA. On Redbox M, the BMCA determines ports A and B to be connected to the time source. Redbox M forwards all Sync and Follow_Up messages received on port C out of ports A and B.

Figure 4: PRP Redbox as DATC with P2P

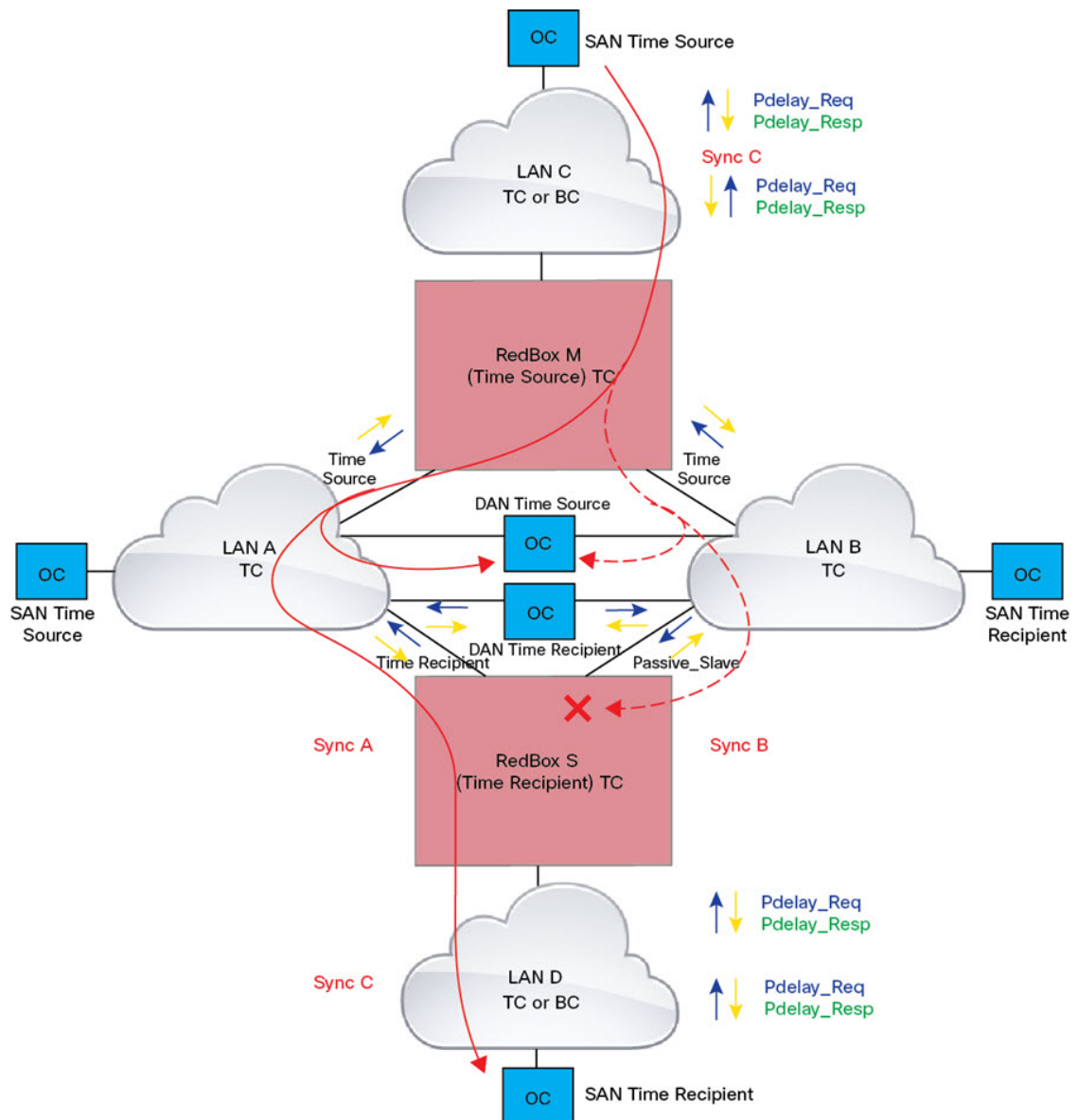

On Redbox S, port A is determined to be time recipient and port B to be PASSIVE_SLAVE as described earlier. Port A and Port B on Redbox S operate as follows:

- Port A works as a regular time recipient port. It uses the Sync and Follow_Up messages along with their correction field to calculate the delay and offset from time source and synchronize the local clock. (Unlike an E2E BC, it does not need to generate Delay_Req messages since all the link delays and residence times along the PTP path are accumulated in the correction field of the Follow_Up messages).
- Like port A, port B maintains the delay and offset from time source, but does not perform any operation on the local clock. Having all the synchronization information available enables it to seamlessly take over as the new time recipient in case port A loses communication with the GMC.

LAN-A and LAN-B Failure Detection and Handling

Failures in LAN-A and LAN-B are detected and handled in the same way for all RedBox types that are described in PRP RedBox Types.

Using the example that is shown in PRP RedBox as DATC with P2P with the GMC as a SAN in LAN C, a failure in LAN-A or LAN-B pertaining to PTP can occur due to the following reasons:

- A device within the LAN goes down.
- A link within the LAN goes down resulting in loss of connectivity.
- PTP messages are dropped within the LAN.

These events result in PTP Announce Receipt Timeout on RedBox S, which triggers the BMCA calculation. Refer to section 7.7.3.1 of the IEEE 1588v2 standard for details on Announce Receipt Timeout.

The BMCA, once invoked, changes the state of the PASSIVE_SLAVE port to time recipient and time recipient to PASSIVE_SLAVE or PASSIVE or FAULTY. The state changes are done atomically to avoid transient cases where there are two time recipient ports or two PASSIVE_SLAVE ports.

RedBox S now synchronizes to the GMC over the new time recipient port. The change to synchronization should be quick and seamless, unless the delays experienced by PTP packets on the two LANs are very different or if there are some non-PTP devices in the LANs.

The SAN time recipient in LAN D also sees this shift in the timing from RedBox S and must converge to the new clock. This is similar to a GMC change event for this clock, but as mentioned earlier, the change is usually seamless.

CLI Commands for PTP over PRP

If you have enabled PTP over PRP on a switch, you can use certain CLI **show** commands to see data for the PTP clock specific for PRP.

You can find information about CLI commands specific to PTP in [Precision Time Protocol Configuration Guide, Cisco Catalyst IE9300 Rugged Series Switches](#). You can find information about CLI commands specific to PRP in this guide.

show ptp clock running

The **show ptp clock running** command shows the summary of the running PTP clock and information about its ports. Use the command to verify that the boundary clock is `PHASE_ALIGNED`—that the clock is in sync with the Grandmaster Clock. Also ensure that one port is in the `Slave` state and the other is in the `Passive Slave` state.

```
RedBox2#show ptp clock running
                PTP Boundary Clock [Domain 0] [Profile: default]
                State      Ports      Pkts sent   Pkts rcvd   Redundancy Mode
                PHASE_ALIGNED  2          168704      150444      Hot standby

                PORT SUMMARY

                PTP Master
Name      Tx Mode      Role          Transport    State          Sessions      Port Addr
dyn1      mcast        negotiated    Ethernet     Slave          1             UNKNOWN
dyn2      mcast        negotiated    Ethernet     Passive Slave  1             UNKNOWN
```

show prp channel detail

Use the **show ptp channel detail** command to view detailed information about both port channels. Ensure that `Gi1/0/21` and `Gi1/0/22` are in the `Inuse` state.

```
RedBox2#show prp channel detail
                PRP-channel listing:
                -----
PRP-channel: PR1
-----
Layer type = L2
Ports: 2      Maxports = 2
Port state = prp-channel is Inuse
Protocol = Enabled
Ports in the group:
  1) Port: Gi1/0/21
     Logical slot/port = 1/21      Port state = Inuse
     Protocol = Enabled
  2) Port: Gi1/0/22
     Logical slot/port = 1/22      Port state = Inuse
     Protocol = Enabled

PRP-channel: PR2
-----
Layer type = L2
Ports: 2      Maxports = 2
Port state = prp-channel is Inuse
Protocol = Enabled
Ports in the group:
  1) Port: Gi1/0/23
     Logical slot/port = 1/23      Port state = Inuse
     Protocol = Enabled
  2) Port: Gi1/0/24
     Logical slot/port = 1/24      Port state = Inuse
     Protocol = Enabled
```

show prp statistics ptpPacketStatistics

The **show prp statistics ptpPacketStatistics** command displays the number of PTP packets ingressing and egressing out of the clock ports when in PRP is enabled. It also displays the drop at the ingress level.

```

RedBox2#show prp statistics ptpPacketStatistics
PRP channel-group 1 PTP STATS:
  ingress lan a: 250
  ingress drop lan a: 0
  ingress lan b: 377
  ingress drop_lan b: 0
  egress lan a: 185
  egress lan b: 188
PRP channel-group 2 PTP STATS:
  ingress lan a: 384
  ingress drop lan a: 0
  ingress lan b: 388
  ingress drop_lan b: 0
  egress lan a: 191
  egress lan b: 193
RB2#

```

show ptp lan port int

The **show ptp lan port int** command displays the port level PTP information for LAN ports, including the port state for PRP.

The following example shows the command and output for port gi1/0/23 on PRP channel 2. Ensure that the port is in SLAVE state.

```

RedBox2#show ptp lan port int gi1/0/23
PTP PORT DATASET: GigabitEthernet1/0/23
  Port identity: clock identity: 0x84:eb:ef:ff:fe:61:70:3f
  Port identity: port number: 3
  PTP version: 2
  Port state: SLAVE
  Peer delay request interval(log mean): 0
  Peer mean path delay(ns): 0
  Sync fault limit: 10000
  Rogue master block: FALSE
  Ingress phy latency: 725
  Egress phy latency: 0

```

The following example shows the command and output for port gi1/0/24 on PRP channel 1. Ensure that the port is in PASSIVE_SLAVE state.

```

RedBox2#show ptp lan port int gi1/0/24
PTP PORT DATASET: GigabitEthernet1/0/24
  Port identity: clock identity: 0x84:eb:ef:ff:fe:61:70:3f
  Port identity: port number: 4
  PTP version: 2
  Port state: PASSIVE_SLAVE
  Peer delay request interval(log mean): 0
  Peer mean path delay(ns): 2
  Sync fault limit: 10000
  Rogue master block: FALSE
  Ingress phy latency: 725
  Egress phy latency: 0

```

ptp clock boundary domain

You can configure a default profile PTP clock boundary domain or a power profile PTP clock boundary domain. When you configure either domain, you must add both PRP member interfaces to the PTP clock.

The following example sets a PTP clock boundary domain for a default profile:

```

ptp clock boundary domain 0 profile default
clock-port dyn1
transport ipv4 multicast interface Gi1/0/21
clock-port dyn2
transport ipv4 multicast interface Gi1/0/22

```

The following example sets a PTP clock boundary domain for a power profile:

```

ptp clock boundary domain 0 profile power
clock-port dyn1
transport ethernet multicast interface Gi1/0/21
clock-port dyn2
transport ethernet multicast interface Gi1/0/22

```

Feature History for PTP over PRP

The following table provides release and related information for the features that are documented in this guide. The features are available in all the releases after the initial release, unless noted otherwise.

Release	Feature	Feature Information
Cisco IOS XE Dublin 17.12.1	Precision Timing Protocol (PTP) over Parallel Redundancy Protocol (PRP)	This feature became available for Cisco Catalyst IE9300 Rugged Series Switches IE-9320-22S2C4X-A and IE-9320-22S2C4X-E in this release.
Cisco IOS XE Cupertino 17.9.x	PTP over PRP	This feature became available for Cisco Catalyst IE9300 Rugged Series Switches IE-9320-26S2C-A and IE-9320-26S2C-E in this release.