



## High-availability Seamless Redundancy

---

- [High-availability Seamless Redundancy, on page 1](#)
- [Guidelines and Limitations, on page 7](#)
- [HSR or PRP on a IE9300 Stack, on page 9](#)
- [Default Settings, on page 11](#)
- [Configure an HSR Ring, on page 12](#)
- [Clear All Node Table and VDAN Table Dynamic Entries, on page 13](#)
- [Verifying the Configuration, on page 14](#)
- [Configuration Examples, on page 14](#)
- [Related Documents, on page 18](#)
- [Feature History, on page 18](#)

## High-availability Seamless Redundancy

High-availability Seamless Redundancy (HSR) is defined in International Standard IEC 62439-3-2016 clause 5. HSR is similar to Parallel Redundancy Protocol (PRP) but is designed to work in a ring topology. Instead of two parallel independent networks of any topology (LAN-A and LAN-B), HSR defines a ring with traffic in opposite directions. Port-A sends traffic counter clockwise in the ring, and Port-B sends traffic clockwise in the ring.

The HSR packet format is also different from PRP. To allow the switch to determine and discard duplicate packets, additional protocol specific information is sent with the data frame. For PRP, this is sent as part of a trailer called the redundancy control trailer (RCT), whereas for HSR this is sent as part of the header called the HSR header. Both the RCT and HSR header contain a sequence number, which is the primary data used to determine if the received frame is the first instance or a duplicate instance.



---

**Note** HSR is supported on certain SKUs of the Cisco Catalyst IE9300 Rugged Series Switches (see the Guidelines and Limitations section in this guide for supported SKUs). The term *switch* in this document refers to a Cisco Catalyst IE9300 Rugged Series Switch unless otherwise noted.

---

In this release, the switch supports only HSR-singly attached node (SAN) and only one HSR instance. In addition, you can create only one HSR or one PRP instance. If you have created a PRP instance, no HSR instance can be created.

The non-switching nodes with two interfaces attached to the HSR ring are referred to as Doubly Attached Nodes implementing HSR (DANHs). Similar to PRP, Singly Attached Nodes (SANs) are attached to the HSR ring through a device called a RedBox (Redundancy Box). The RedBox acts as a DANH for all traffic for which it is the source or the destination. The switch implements RedBox functionality using Gigabit Ethernet port connections to the HSR ring.

The following figure shows an example of an HSR ring as described in IEC 62439-3. In this example, the RedBox is an Cisco Catalyst IE9300 Rugged Series Switch.

**Figure 1: Example of HSR Ring Carrying Unicast Traffic**

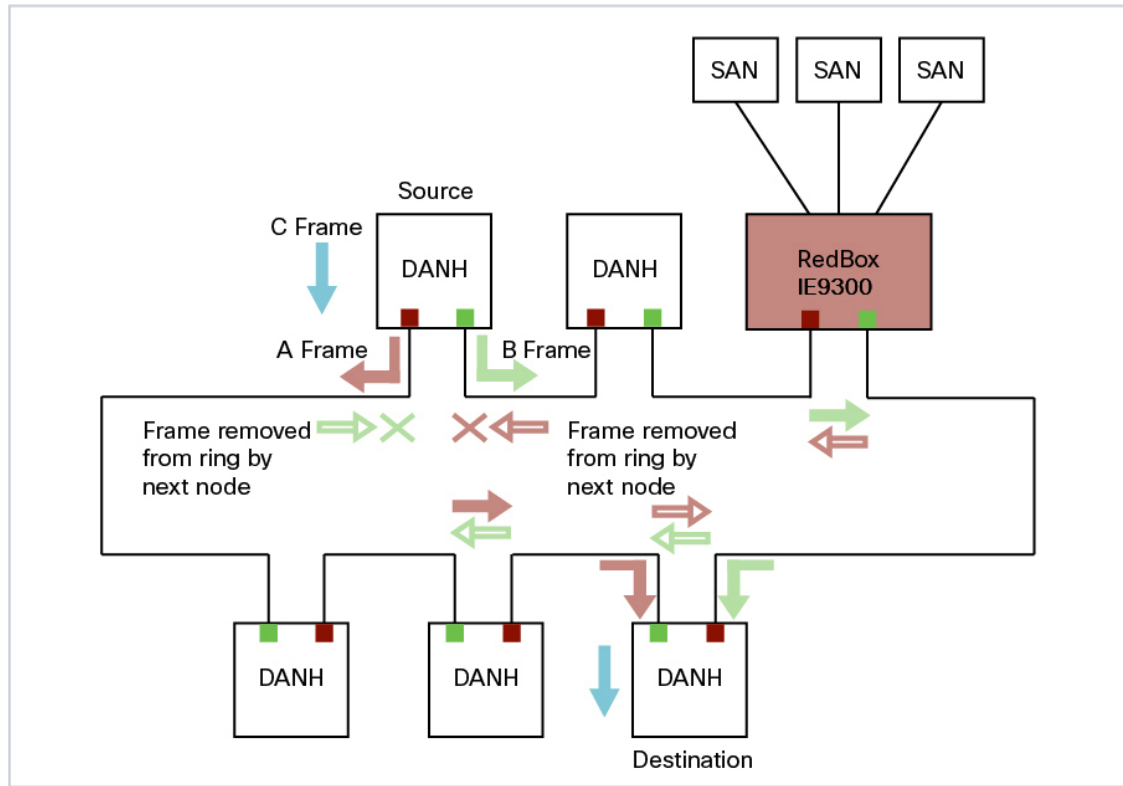

Devices that do not support HSR out of the box (for example, laptops and printers) cannot be attached to the HSR ring directly because all HSR capable devices must be able to process the HSR header on packets received from the ring and add the HSR header to all packets sent into the ring. These nodes are attached to the HSR ring through a RedBox. As shown in the figure above, the RedBox has two ports on the DANH side. Non-HSR SAN devices are attached to the upstream switch ports. The RedBox generates the supervision frames on behalf of these devices so that they are seen as DANH devices on the ring. Because the RedBox emulates these as DANH, they are called Virtual Doubly Attached Nodes (VDAN).

## Loop Avoidance

Each node in the HSR ring forwards frames received from one port to the other port of the HSR pair. To avoid loops and use network bandwidth effectively, the RedBox does not transmit frames that are already transmitted in same direction. When a node injects a packet into the ring, the packet is handled as follows to avoid loops:

- Unicast packet with destination inside the ring: When the unicast packet reaches the destination node, the packet is consumed by the respective node and is not forwarded.

- Unicast packet with destination not inside the ring: Because this packet does not have a destination node in the ring, it is forwarded by every node in the ring until it reaches the originating node. Because every node has a record of the packet it sent, along with the direction in which it was sent, the originating node detects that packet has completed the loop and drops the packet.
- Multicast packet: A multicast packet is forwarded by each node because there can be more than one consumer of this packet. For this reason a multicast packet always reaches the originating node. However, every node will check whether it has already forwarded the received packet through its outgoing interface. Once the packet reaches the originating node, the originating node determines that it already forwarded this packet and drops the packet instead of forwarding it again.

## HSR RedBox Modes of Operation

The most basic mode of operation is HSR-SAN mode (single RedBox mode). In this mode, the RedBox is used to connect SAN devices to the HSR ring. The Redbox's responsibility in this mode is to represent SAN devices as VDANs on the ring.



---

**Note** In this release, the switch supports HSR-SAN mode only.

---

## HSR SAN Mode

In HSR-SAN mode, the RedBox inserts the HSR tag on behalf of the host and forwards the ring traffic, except for frames sent by the node itself, duplicate frames, and frames for which the node is the unique destination. In this mode, packets are handled as follows:

- A source DANH sends a frame passed from its upper layers (C frame), prefixes it with an HSR tag to identify frame duplicates, and sends the frame over each port (A frame and B frame).
- A destination DANH receives two identical frames from each port within a certain interval. The destination DANH removes the HSR tag of the first frame before passing it to its upper layers and discards any duplicate.
- Each node in the HSR ring forwards frames received from one port to the other port of the HSR pair. A node will not forward frames received on one port to the other under the following conditions:
  - The received frame returns to the originating node in the ring.
  - The frame is a unicast frame with a destination MAC address of a node upstream of the receiving node.
  - The node had already sent the same frame in the same direction. This rule prevents a frame from spinning in the ring in an infinite loop.

## CDP and LLDP for HSR

HSR supports the Cisco Discovery Protocol (CDP) and Link Layer Discovery Protocol (LLDP). CDP and LLDP are Layer 2 neighbor discovery protocols. Both CDP and LLDP can provide information about nodes

directly connected to the device. They also provide additional information such as the local and remote interface and device names.

When CDP or LLDP is enabled, you can use the CDP or LLDP information to find the adjacent nodes on an HSR ring and their status. You can then use the neighbor information from each node to determine the complete HSR network topology and debug and locate ring faults.

CDP and LLDP are configured on physical interfaces only.

For more information, see [Configuring an HSR Ring](#) and [Verifying Configuration](#).

## HSR Uplink Redundancy Enhancement

The HSR Uplink Redundancy Enhancement feature allows for flexible designs that enable two separate interfaces to connect upstream from the HSR ring through two separate HSR RedBoxes. This ensures there is no single point of failure exiting the HSR ring. Examples of protocols that can leverage this feature to improve high availability include HSRP, VRRP and REP. Prior to this enhancement, if these protocols were utilized on redundant uplinks, undesirable results could occur, such as next-hop split-brain conditions or slow REP failover times.

The following diagram shows an example network with HSR and HSRP that allows uplink next-hop gateway redundancy out of the HSR ring.

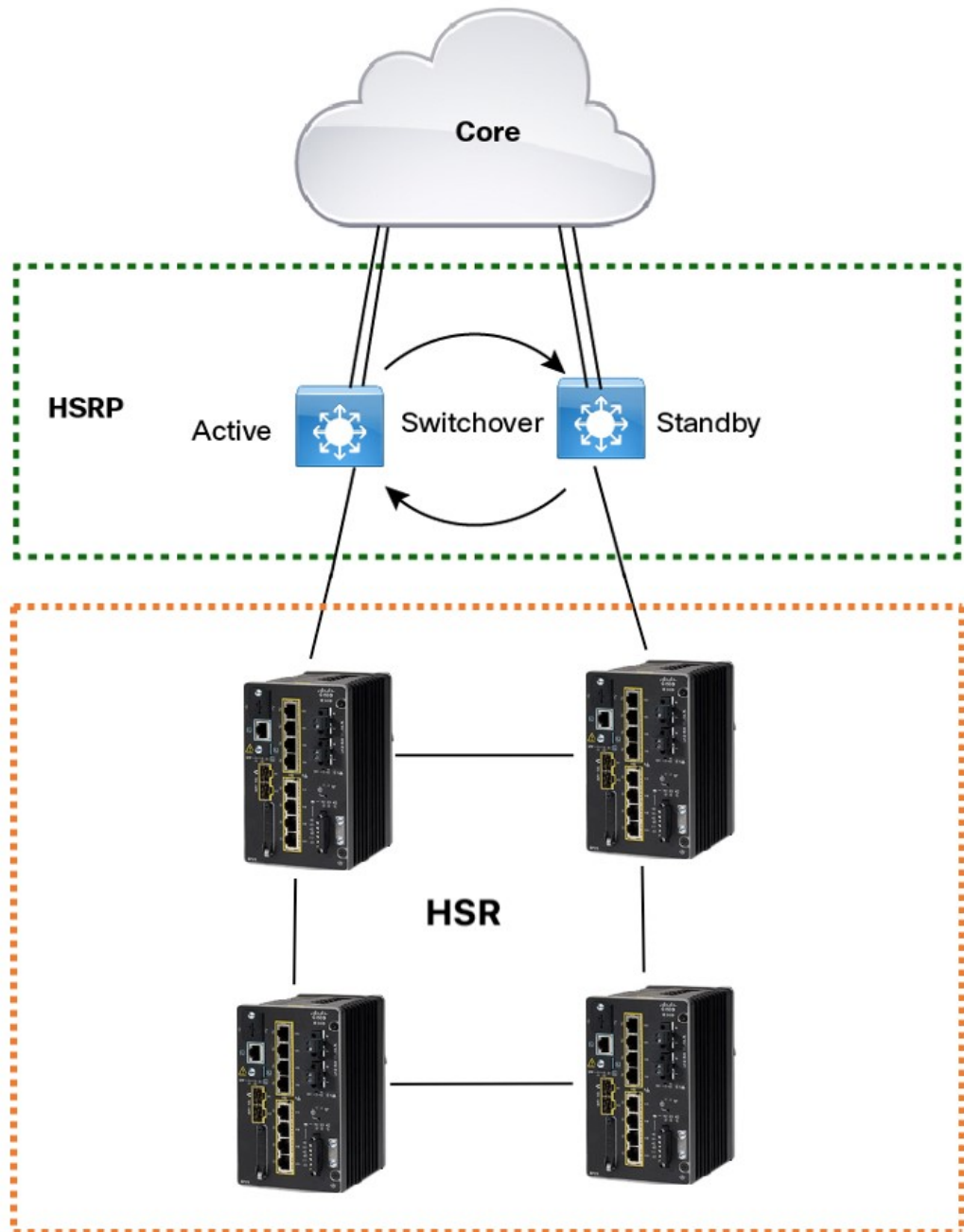

To implement HSR Uplink Redundancy, ensure that the **fpgamode-DualUplinkEnhancement** feature is not disabled. This feature is required to support the connectivity to a dual router (HSRP in this case) on the distribution layer:

```
Switch#show hsr ring 1 detail | include fpgamode
fpgamode-DualUplinkEnhancement: Enabled
```

If the output shows *fpgamode-DualUplinkEnhancement,;Disabled* issue the following command:

```
Switch# conf t
Enter configuration commands, one per line. End with CNTL/Z.
Switch(config)# hsr-ring 1 fpgamode-DualUplinkEnhancement
Switch(config)# end
```

## HSRP Configuration

The following example HSRP configuration applies to the two distribution switches Active & Standby in the above figure. In the following configuration, HSRP is configured in a Switch Virtual Interface (SVI).

```
Active# conf t
Enter configuration commands, one per line. End with CNTL/Z.
Active(config)# interface vlan 10
Active(config-if)# ip address 30.30.30.2 255.255.255.0
Active(config-if)# standby 1 ip 30.30.30.1
Active(config-if)# standby 1 priority 120
Active(config-if)# end
```

```
Standby# conf t
Enter configuration commands, one per line. End with CNTL/Z.
Standby(config)# interface Vlan10
Standby(config-if)# ip address 30.30.30.4 255.255.255.0
Standby(config-if)# standby 1 ip 30.30.30.1
Standby(config-if)# end
```

```
Active# show standby
Vlan10 - Group 1
  State is Active
    8 state changes, last state change 00:03:55
    Track object 1 (unknown)
  Virtual IP address is 30.30.30.1
  Active virtual MAC address is 0000.0c07.ac01 (MAC In Use)
    Local virtual MAC address is 0000.0c07.ac01 (v1 default)
  Hello time 200 msec, hold time 750 msec
    Next hello sent in 0.176 secs
  Preemption enabled, delay min 5 secs, reload 5 secs, sync 5 secs
  Active router is local
  Standby router is 30.30.30.4, priority 100 (expires in 0.656 sec)
  Priority 120 (configured 120)
  Group name is "hsrp-Vl10-1" (default)
  FLAGS: 0/1
```

```
Active# show standby brief
          P indicates configured to preempt.
          |
Interface   Grp  Pri P State   Active           Standby           Virtual IP
Vl10        1    120 P Active local           30.30.30.4       30.30.30.1
```

```
Standby# show standby
Vlan10 - Group 1
  State is Standby
    13 state changes, last state change 00:04:17
    Track object 1 (unknown)
  Virtual IP address is 30.30.30.1
  Active virtual MAC address is 0000.0c07.ac01 (MAC Not In Use)
    Local virtual MAC address is 0000.0c07.ac01 (v1 default)
  Hello time 200 msec, hold time 750 msec
    Next hello sent in 0.064 secs
  Preemption enabled, delay min 5 secs, reload 5 secs, sync 5 secs
  Active router is 30.30.30.2, priority 120 (expires in 0.816 sec)
  Standby router is local
  Priority 100 (default 100)
  Group name is "hsrp-Vl10-1" (default)
```

```

FLAGS: 0/1
Standby# show standby brief
                P indicates configured to preempt.
                |
Interface      Grp  Pri P State      Active      Standby      Virtual IP
Vl10           1   100 P Standby  30.30.30.2  local        30.30.30.1

```

## Guidelines and Limitations

- HSR-SAN is supported only on the following Cisco Catalyst IE9300 Rugged Series Switches:
  - IE-9320-26S2C-E and IE-9320-26S2C-A
  - IE-9320-22S2C4X-E and IE-9320-22S2C4X-A
- HSR-SAN (Single RedBox mode) is the only HSR mode supported in this release.
- HSR is supported only in a standalone deployment; there is no support for HSR for stacked switches.
- Only one HSR instance is supported. Note that the switch supports only one HSR or one PRP instance, so if a PRP instance has been created, no HSR instance can be created.
- HSR ring 1 can only be configured as a pair of ports: Gi1/0/21 and Gi1/0/22 or Gi1/0/23 and Gi1/0/24. Using these port pairs, you can configure 1 HSR ring.
- The HSR feature requires the Network Essentials license.
- The HSR feature is not enabled by default and you must explicitly configure the HSR rings.
- HSR is disabled automatically if the required firmware image is not available on the system.
- Once a port is part of a ring, the media-type, speed, and duplex settings of the port cannot be changed. We recommend that you apply those settings before configuring ring membership.
- If mode of HSR interfaces is changed from access to trunk mode or vice-versa after configuring the ring, we recommended that you flap the HSR ring.
- The recommended maximum number of nodes in the node table is 512. Nodes are all the DANH and VDAN devices that can be connected to the ring at same time. This number is not an absolute limit, but higher numbers of entries may increase the number of duplicate packets received by the end devices.
- The maximum number of nodes in the HSR ring is 50.
- HSR ring ports can only be configured in L2 mode.
- HSR is supported on following port types:
  - 100 mbps, Full Duplex. Half duplex is not supported.
  - 1000 mbps, Full Duplex. Half duplex is not supported.
  - HSR is not supported on the uplink ports.
- Both ports of one ring must be of same speed and type (that is, both can be SFPs or both can be copper)
- The following protocols and features are mutually exclusive with HSR on the same port:
  - PRP

- EtherChannels
  - Link Aggregation Control Protocol (LACP)
  - Port Aggregation Protocol (PAgP)
  - Resilient Ethernet Protocol (REP)
- MACsec, HSR, and PRP are not allowed together.
  - PTP over HSR is not supported.
  - HSR supports an MTU size of up to 1998 bytes of Ethernet payload.
  - STP is not supported on the HSR ring. By default, all modes of Spanning Tree Protocol (STP) will be disabled on the ring ports.
  - Switched Port Analyzer (SPAN) and Remote SPAN (RSPAN) are not supported on HSR. That is, SPAN and RSPAN should not be used to monitor the traffic on an HSR ring. In addition, traffic that has been monitored using RSPAN should not be transferred over an HSR ring.
  - It is important for all interfaces in an HSR ring to have the same speed and duplex settings. It is recommended to apply those settings before configuring ring membership.
  - Once a port is part of ring, the port cannot be shut down.

For example, if Gi1/0/23 and Gi1/0/24 are part of an HSR ring and you try to shut down Gi1/0/23 or Gi1/0/24, the operation will not be permitted:

```
Switch(config)# interface range gi1/0/23-24
Switch(config-if-range)#shutdown
%Interface GigabitEthernet1/0/23 is configured in a HSR ring shutdown not permitted!
Switch(config-if-range)#
```

You can perform a shutdown of the HSR ring. For example:

```
Switch# conf t
Switch(config)#int hs1
Switch(config-if-range)#shut
```

- VLAN configuration such as trunk and access mode must be the same on both the ports participating in the ring. For example, if Gi1/0/24 and Gi1/0/23 in an HSR ring are in trunk mode and you attempt to change the mode of one port to access, the ports in the ring will not be bundled:

```
Switch(config)# interface range gi1/0/23-24
Switch(config-if-range)# switchport mode access
Jul 27 22:00:27.809 IST: %EC-5-CANNOT_BUNDLE2: Gi1/0/23 is not compatible with Gi1/0/24
and will be suspended (trunk mode of Gi1/0/23 is access, Gi1/0/24 is dynamic)
```

- After an interface is added in the HSR ring, only the primary interface counters are updated. You should not need to configure and check the status of individual physical interfaces after they are added to the HSR ring.
- As soon as you configure an HSR ring on two ports of a switch, MAC flaps will be observed on other switches where the HSR configuration is yet to be applied. We recommend that you shut down the newly created HSR ring on the switch before configuring the ring on all switches, and then re-enable them one by one as shown below. For example, if there are four switches in the ring, disable the HSR ring interfaces on each switch:

```
Switch1(config)# interface range gi1/0/21-22
Switch1(config-if-range)# shutdown
```



```
Switch1(config-if-range)# hsr-ring 1
Creating a HSR-ring interface hs1
Switch1(config-if-range)# int hs1
Switch1(config-if-range)# shutdown
Switch1(config-if-range)# end
```

After all four switches are configured with the ring, re-enable the HSR ports on each switch:

```
Switch1# conf t
Enter configuration commands, one per line. End with CNTL/Z.
Switch1(config)# interface range gi1/0/21-22
Switch1(config-if-range)# int hs1
Switch1(config-if-range)# no shutdown
Switch1(config-if-range)# end
Switch1#
```

This prevents interim MAC flapping during HSR ring configuration in member switches.

## HSR or PRP on a IE9300 Stack

The Parallel Redundancy Protocol (PRP) offers significant advantages in facilitating redundancy with zero downtime. High-availability Seamless Redundancy (HSR) is similar to PRP but is designed to work in a ring topology. While the initial implementation was limited to standalone switches, recent advancements have enabled PRP or HSR to be utilized in stacked configurations.

### Benefits of PRP or HSR on a IE9300 Stack

Deploying PRP or HSR in a stacked setup introduces a node level redundancy within the network.

- This enhancement mitigates the risk of single points of failure.
- Ensures the system remains operational even if a stack member or the active switch fails.
- The functionality and behavior of PRP and HSR remain consistent in both standalone and stacked configurations.
- Provides seamless integration and reliability across the network.

For more information on Switch Stacks, see [Managing Switch Stacks](#).



---

**Note** There are no changes to the functionality or behavior of PRP and HSR when implemented in a IE9300 stack compared to their standalone configurations.

---

The following illustration displays a IE9300 stack as a RedBox.

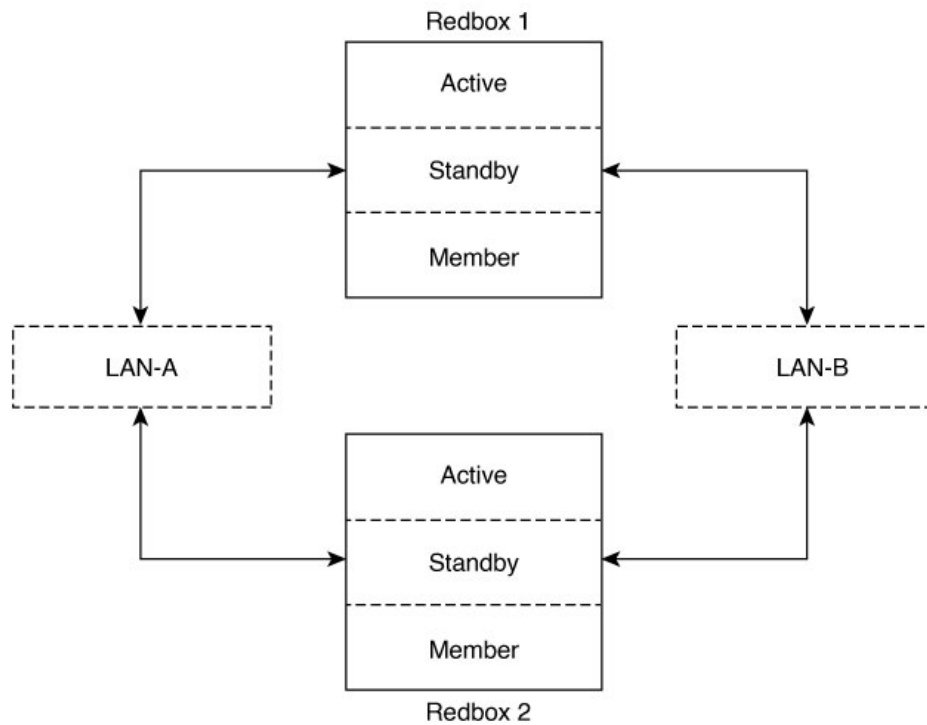

**Note** A maximum of four-member stack can be configured with PRP or HSR as RedBox.

### Guidelines and Limitations

The following guidelines and limitations apply:

- You can create any one of the following configurations:
  - HSR: Maximum of two rings
  - or
  - PRP: Maximum of two channels
  - or
  - One HSR ring and one PRP channel
- PRP and HSR are supported on IE-9320-26S2C and IE-9320-22S2C4X only.
- PRP and HSR on IE9300 stack is supported only if both the active and standby switches are FPGA-based SKUs.
- Both ports of a channel and a ring must be on the same slot, that is, the primary and secondary interfaces must be on the same switch member.
- When PRP or HSR is configured on the active unit and the switch goes down, it remains unavailable until the switch is restored.

### Active-Standby Synchronization Mechanism Post-Switchover

Synchronization of the PRP or HSR to a redundant standby, supports both incremental and bulk synchronization updates.

The behavior of PRP channel or HSR ring when a switch goes down, is as follows:

- If the channel or ring is configured on the standby switch, it will synchronize with the previous states of the channel or ring from the last active configuration.
- If the channel or ring is configured on the active switch, it will transition to a down state due to the slot being inactive. Once the slot is reactivated, the volatile FPGA will be reprogrammed with the previously configured values.

## Default Settings

*Table 1: HSR Ring Parameters*

Parameter	Description	Range	Default Value
entryForgetTime	Time for clearing an inactive entry from duplicate discard table.	0-65535	400 ms
fpgamode-DualUplinkEnhancement	Set FPGA register for source mac filtering.	enable or disable	enable
nodeForgetTime	Time to clear an inactive entry from the node table.	0-65535	6000 ms
nodeRebootInterval	Time after which the RedBox must start sending supervision frames after bootup.	0-65535	500 ms
pauseFrameTime	Time interval between HSR pause frames.	0-65535	25 ms
proxyNodeTableForgetTime	Time to clear an inactive entry from the proxy node table or vdan table.	0-65535	6000 ms
supervisionFrameLifeCheckInterval	Life check interval value for supervision frames.	0-65535	2000 ms
supervisionFrameOption			
mac-da	The last bytes of the destination MAC address of supervision frames (01:15:4E:00:01:00). The last 00 is replaced by the value of this parameter.	1-255 MAC DA last eight bits option value	No default

Parameter	Description	Range	Default Value
vlan-cfi	Enable Canonical Format Indicator (CFI) for the VLAN tagged frame.	enable or disable	disable
vlan-cos	Class of Service (COS) value to be set in the VLAN tag of the Supervision frame.	0-7	0
vlan-id	The VLAN tag of the supervision frame.	0-4095	0
vlan-tagged	Set VLAN tagging option.	enable or disable	disable
supervisionFrameRedboxMacaddress	The RedBox MAC address in the supervision frames.	48-bit RedBox MAC address	The interface HSR ring MAC address
supervisionFrameTime	Time interval between supervision frames.	0-65535	3 ms

## Configure an HSR Ring

Follow these steps to configure an HSR ring:

### Before you begin

- Read and understand the [Guidelines and Limitations, on page 7](#) section of this chapter.
- Ensure that the member interfaces of a HSR ring are not participating in any redundancy protocols such as FlexLinks, EtherChannel, REP, and so on before configuring a HSR ring.

### Procedure

**Step 1** Enter global configuration mode:

```
Switch# configure terminal
```

**Step 2** (Optional) Globally enable CDP to provide information about HSR ring nodes:

```
Switch(config)# cdp run
```

**Step 3** (Optional) Globally enable LLDP to provide information about HSR ring nodes:

```
Switch(config)# lldp run
```

**Step 4** Enter interface configuration mode and disable PTP on the ports to be assigned to the HSR ring:

```
Switch(config)# interface range gi1/0/21-22  
Switch(config-if-range)# no ptp enable
```

**Step 5** (Optional) Enable CDP on the ports to be assigned to the HSR ring:

```
Switch(config-if-range)#cdp enable
```

**Step 6** (Optional) Enable LLDP on the ports to be assigned to the HSR ring:

```
Switch(config-if-range)#lldp transmit
Switch(config-if-range)#lldp receive
```

**Step 7** Shut down the ports before configuring the HSR ring:

```
Switch(config-if-range)# shutdown
```

**Step 8** Create the HSR ring interface and assign the ports to the HSR ring:

```
Switch(config)# interface range gigabitEthernet 1/0/21-22
Switch(config-if-range)# hsr-ring 1
```

**Step 9** (Optional) If required, configure HSR ring optional parameters. See the Default Settings section for the parameter descriptions, ranges and default values.

```
Switch(config-range)# hsr 1 supervisionFrameLifeCheckInterval 10000
```

**Step 10** Turn on the HSR interface:

```
Switch(config-if-range)# no shutdown
Switch(config-if-range)# end
```

---

### Example

```
Switch# conf t
Enter configuration commands, one per line. End with CNTL/Z.
Switch(config)# interface range gigabitEthernet 1/0/21-22
Switch(config-if-range)# no ptp enable
Switch(config-if-range)# shutdown
Switch(config-if-range)# hsr-ring 1
Switch(config-if-range)# hsr-ring 1 supervisionFrameLifeCheckInterval 10000
Switch(config-if-range)# no shutdown
Switch(config-if-range)# end
```

## Clear All Node Table and VDAN Table Dynamic Entries

### Procedure

---

**Step 1** To clear all dynamic entries in the node table, enter the following command: **clear hsr node-table**

**Step 2** To clear all dynamic entries in the VDAN table, enter the following command; **clear hsr vdan-table**

---

## Verifying the Configuration

Command	Purpose
<code>show hsr ring 1 [detail ]</code>	Displays configuration details for the specified HSR ring.
<code>show hsr statistics {egressPacketStatistics   ingressPacketStatistics   nodeTableStatistics   pauseFrameStatistics}</code>	Displays statistics for HSR components. <b>Note</b> To clear HSR statistics information, enter the command <code>clear hsr statistics</code> .
<code>show hsr node-table</code>	Displays HSR node table.
<code>show hsr vdan-table</code>	Displays HSR Virtual Doubly Attached Node (VDAN) table. <b>Note</b> The VDAN table and Proxy node table are the same.
<code>show cdp neighbors</code>	Displays CDP neighbor information for an HSR ring.
<code>show lldp neighbors</code>	Displays LLDP neighbor information for an HSR ring.

## Configuration Examples

### HSR-SAN

This example shows the configuration of an HSR ring (Ring 1) using Gi1/0/23 and Gi1/0/24 ports between four devices.

Figure 2: HSR Ring Configuration with Four Devices

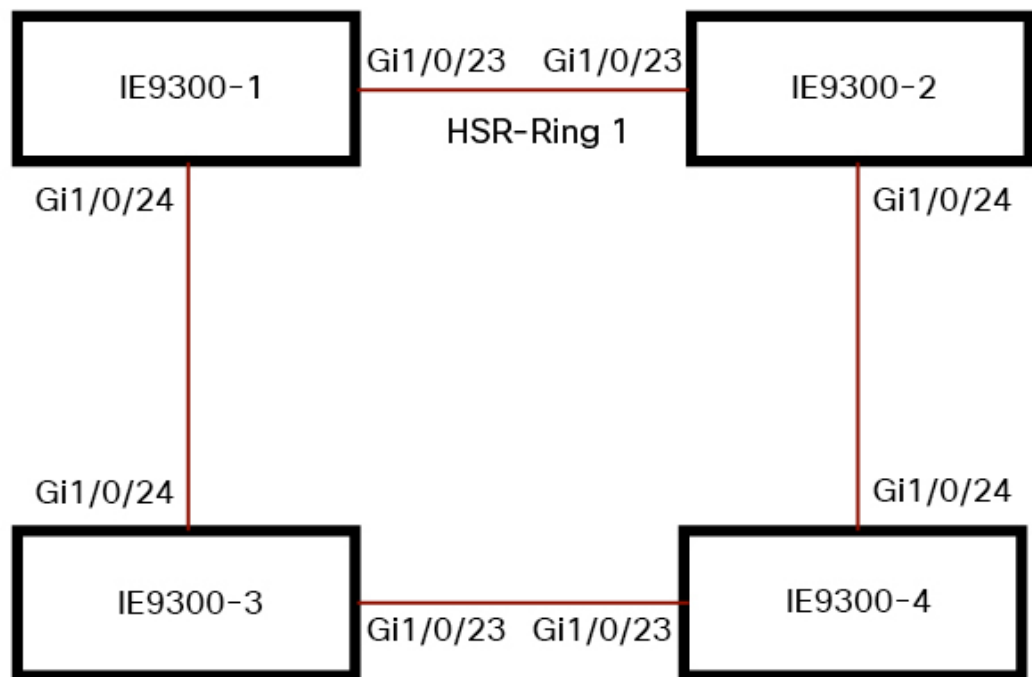

```

IE9300-1# conf t
Enter configuration commands, one per line. End with CNTL/Z.
IE9300-1(config)# interface range gi1/0/23-24
IE9300-1(config-if-range)# shutdown
IE9300-1(config-if-range)# hsr-ring 1
IE9300-1(config-if-range)# no shutdown
IE9300-1(config-if-range)# end
IE9300-1#
IE9300-2# conf t
Enter configuration commands, one per line. End with CNTL/Z.
IE9300-2(config)# interface range gi1/0/23-24
IE9300-2(config-if-range)# shutdown
IE9300-2(config-if-range)# hsr-ring 1
IE9300-2(config-if-range)# no shutdown
IE9300-2(config-if-range)# end
IE9300-2#
IE9300-3# conf t
Enter configuration commands, one per line. End with CNTL/Z.
IE9300-3(config)# interface range gi1/0/23-24
IE9300-3(config-if-range)# shutdown
IE9300-3(config-if-range)# hsr-ring 1
IE9300-3(config-if-range)# no shutdown
IE9300-3(config-if-range)# end
IE9300-3#
IE9300-4# conf t
Enter configuration commands, one per line. End with CNTL/Z.
IE9300-4(config)# interface range gi1/0/23-24
IE9300-4(config-if-range)# shutdown
IE9300-4(config-if-range)# hsr-ring 1
IE9300-4(config-if-range)# no shutdown
IE9300-4(config-if-range)# end
IE9300-4(config-if-range)# end

```

```

IE9300-4#
IE9300-1# sh hsr ring 1 detail
HSR-ring: HS1
-----
Layer type = L2
Operation Mode = mode-H
Ports: 2          Maxports = 2
Port state = hsr-ring is Inuse
Protocol = Enabled Redbox Mode = hsr-san
Ports in the ring:
  1) Port: Gil/0/23
     Logical slot/port = 1/3      Port state = Inuse
     Protocol = Enabled
  2) Port: Gil/0/24
     Logical slot/port = 1/4      Port state = Inuse
     Protocol = Enabled

Ring Parameters:
Redbox MacAddr: f454.3365.8a84
Node Forget Time: 60000 ms
Node Reboot Interval: 500 ms
Entry Forget Time: 400 ms
Proxy Node Forget Time: 60000 ms
Supervision Frame COS option: 0
Supervision Frame CFI option: 0
Supervision Frame VLAN Tag option: Disabled
Supervision Frame MacDa: 0x00
Supervision Frame VLAN id: 0
Supervision Frame Time: 3 ms
Life Check Interval: 2000 ms
Pause Time: 25 ms

IE9300-2# show hsr ring 1 detail
HSR-ring: HS1
-----
Layer type = L2
Operation Mode = mode-H
Ports: 2          Maxports = 2
Port state = hsr-ring is Inuse
Protocol = Enabled Redbox Mode = hsr-san
Ports in the ring:
  1) Port: Gil/0/23
     Logical slot/port = 1/3      Port state = Inuse
     Protocol = Enabled
  2) Port: Gil/0/24
     Logical slot/port = 1/4      Port state = Inuse
     Protocol = Enabled

Ring Parameters:
Redbox MacAddr: 34c0.f958.ee83
Node Forget Time: 60000 ms
Node Reboot Interval: 500 ms
Entry Forget Time: 400 ms
Proxy Node Forget Time: 60000 ms
Supervision Frame COS option: 0
Supervision Frame CFI option: 0
Supervision Frame VLAN Tag option: Disabled
Supervision Frame MacDa: 0x00
Supervision Frame VLAN id: 0
Supervision Frame Time: 3 ms
Life Check Interval: 2000 ms
Pause Time: 25 ms

IE9300-4# sh hsr ring 1 de

```



```
HSR-ring: HS1
-----
Layer type = L2
Operation Mode = mode-H
Ports: 2          Maxports = 2
Port state = hsr-ring is Inuse
Protocol = Enabled Redbox Mode = hsr-san
Ports in the ring:
  1) Port: Gi1/0/23
     Logical slot/port = 1/3      Port state = Inuse
     Protocol = Enabled
  2) Port: Gi1/0/24
     Logical slot/port = 1/4      Port state = Inuse
     Protocol = Enabled

Ring Parameters:
Redbox MacAddr: f454.3312.5104
Node Forget Time: 60000 ms
Node Reboot Interval: 500 ms
Entry Forget Time: 400 ms
Proxy Node Forget Time: 60000 ms
Supervision Frame COS option: 0
Supervision Frame CFI option: 0
Supervision Frame VLAN Tag option: Disabled
Supervision Frame MacDa: 0x00
Supervision Frame VLAN id: 0
Supervision Frame Time: 3 ms
Life Check Interval: 2000 ms
Pause Time: 25 ms
```

```
IE9300-3# sh hsr ring 1 detail
```

```
HSR-ring: HS1
-----
Layer type = L2
Operation Mode = mode-H
Ports: 2          Maxports = 2
Port state = hsr-ring is Inuse
Protocol = Enabled Redbox Mode = hsr-san
Ports in the ring:
  1) Port: Gi1/0/23
     Logical slot/port = 1/3      Port state = Inuse
     Protocol = Enabled
  2) Port: Gi1/0/24
     Logical slot/port = 1/4      Port state = Inuse
     Protocol = Enabled

Ring Parameters:
Redbox MacAddr: f454.335c.4684
Node Forget Time: 60000 ms
Node Reboot Interval: 500 ms
Entry Forget Time: 400 ms
Proxy Node Forget Time: 60000 ms
Supervision Frame COS option: 0
Supervision Frame CFI option: 0
Supervision Frame VLAN Tag option: Disabled
Supervision Frame MacDa: 0x00
Supervision Frame VLAN id: 0
Supervision Frame Time: 3 ms
Life Check Interval: 2000 ms
Pause Time: 25 ms
```

## Related Documents

- [Cisco Catalyst IE9300 Rugged Series Switch](#) documentation.
- IEC 62439-3, Industrial communication networks - High availability automation networks - Part 3: Parallel Redundancy Protocol (PRP) and High-availability Seamless Redundancy (HSR)

## Feature History

Feature Name	Release	Feature Information
High-Availability Seamless Redundancy (HSR)—HSR-SAN (Single RedBox mode)	Cisco IOS XE 17.13.1	Initial support for Cisco Catalyst IE9300 Rugged Series Switches