



## **Cisco Catalyst 9600 Series Switches Hardware Installation Guide**

**First Published:** 2019-04-15

**Last Modified:** 2024-02-02

### **Americas Headquarters**

Cisco Systems, Inc.  
170 West Tasman Drive  
San Jose, CA 95134-1706  
USA  
<http://www.cisco.com>  
Tel: 408 526-4000  
800 553-NETS (6387)  
Fax: 408 527-0883



# CONTENTS

---

## CHAPTER 1

### Product Overview 1

- Chassis Overview 1
- Fan Tray Assembly 4
  - High Availability 6
  - Thresholds, Alarms, and Abnormal Acoustic Conditions 7
- Power Supply Module Overview 7
  - AC Power Supply Module 8
  - DC Power Supply Module 10
  - Power Supply Modes 11

---

## CHAPTER 2

### Preparing for Installation 13

- Safety Warnings 13
- SFP and QSFP Module Ports 17
- Site Requirements 19
  - Temperature 19
  - Air Flow 20
  - Humidity 22
  - Altitude 22
  - Dust and Particles 22
  - Air Quality 23
  - Corrosion 23
  - EMI and Radio Frequency Interference 24
  - Shock and Vibration 25
  - Power Source Interruptions 25
  - System Grounding 26

Maintaining Safety with Electricity	28
Preventing ESD Damage	29
Power Requirements	30
Cabling Requirements	30
Rack-Mounting Guidelines	30
Site Preparation Checklist	32

**CHAPTER 3****Installing the Switch 35**

Unpacking the Switch	35
Install the Switch as Shipped	36
Installing the Cable Guide on the Chassis with L-Brackets Preinstalled on the Chassis	36
Rack-Mounting the Chassis as Shipped	38
Install the Switch with Shelf Brackets	42
Installing the Shelf Kit L-Brackets	42
Installing the Shelf Brackets and the Crossbar	46
Installing the Cable Guide on the Chassis with Shelf Kit L-Bracket	48
Rack-Mounting the Chassis	49
Install the Switch in NEBS-Compliant Mode	56
NEBS-Compliant Air Filter	56
Rack-Mounting the Chassis in NEBS-Compliant Mode	56
Establishing System Ground	64
Attaching an ESD Strap	66
Verifying the Switch Chassis Installation	67

**CHAPTER 4****Installing the Fan Tray 69**

Guidelines for Removing and Installing a Fan Tray	69
Removing a Fan Tray	69
Information About Replacing a Fan Tray	69
Enabling the Service Mode Before Removing the Fan Tray	70
Removing the Fan Tray from the Front of the Chassis	71
Removing the Fan Tray from the Rear of the Chassis	73
Installing a Fan Tray	76
Installing the Fan Tray from the Front Panel of the Chassis	77
Installing the Fan Tray from the Rear of the Chassis	78

Verifying Fan Tray Installation 79

---

**CHAPTER 5**

**Installing a Power Supply Unit 81**

- Required Tools and Equipment 81
- Removing and Installing Power Supply Modules 81
  - Removing a Power Supply Module 83
  - Installing a Power Supply Module 85
- Connecting to a Power Source 88
  - Connecting to an AC Power Source 88
  - Connecting to a DC Power Source 89
- Verifying the Power Supply Installation 92
- Removing and Installing Power Supply Blanks 92
- Finding the Serial Number 96

---

**APPENDIX A**

**Technical Specifications 97**

- C9606R Switch Chassis Specifications 97
- Power Supply Specifications 99
  - 2000W AC-Input Power Supply Specifications 99
  - 2000WAC Power Supply AC Power Cords 100
  - 2000W DC-Input Power Supply Specifications 104
  - 3000W AC-Input Power Supply Specifications 106
  - 3000W AC Power Supply AC Power Cords 107
- Chassis and Module Power and Heat Values 109
- Weight Specifications 110

---

**APPENDIX B**

**LEDs 113**

- Fan Tray LEDs 113
- Power Supply Modules LEDs 114
- Supervisor Module LEDs 115
- Line Card LEDs 116

---

**APPENDIX C**

**Accessory Kit and Shelf Kit Contents 119**

- Standard Accessory Kit Contents 119
- Shelf Kit Contents 119

23-Inch Rack Mount Kit Contents 120  
23-Inch Rack Mount NEBS Kit Contents 121





# CHAPTER 1

## Product Overview

- [Chassis Overview, on page 1](#)
- [Fan Tray Assembly, on page 4](#)
- [Power Supply Module Overview, on page 7](#)

## Chassis Overview

The Cisco Catalyst 9606R Switch is a six-slot chassis, with two redundant supervisor module slots, four module slots, four power supply modules and a fan tray.

**Table 1: Cisco Catalyst 9600R Switch Features**

Feature	Description
Product ID	Cisco Catalyst 9606R
Chassis	Has six horizontal slots. Slots are numbered 1 to 6 from top to bottom.
Supervisor modules	Accommodates two supervisor modules. The following are the supported models: Cisco Catalyst 9600 Series Supervisor 1 Module (C9600-SUP-1) and Cisco Catalyst 9600 Series Supervisor 2 Module (C9600X-SUP-2).  For more information about installing a supervisor module, see the <i>Cisco Catalyst 9600 Series Supervisor Engine Installation Note</i> .

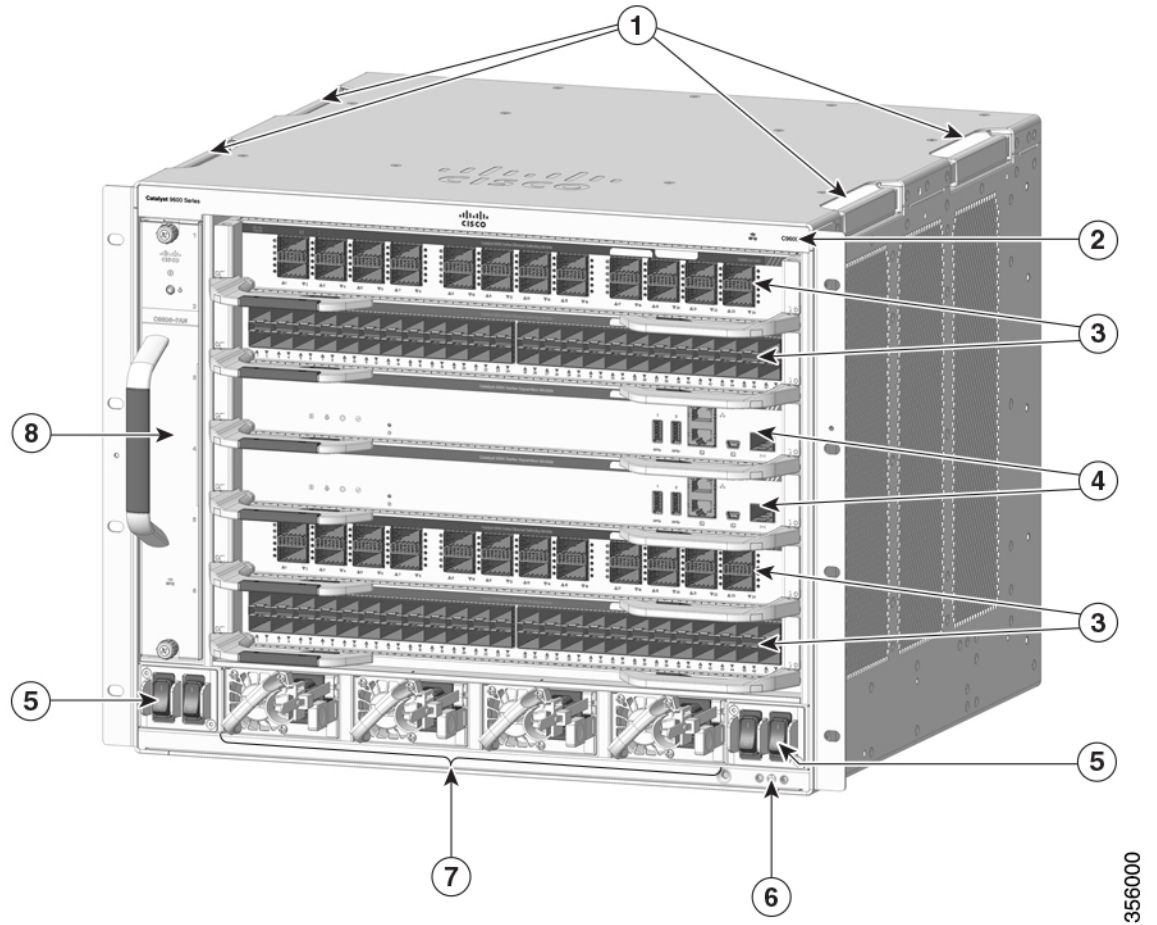
Feature	Description
Line Cards	<p>Accommodates up to four line cards. The following are the supported line cards:</p> <ul style="list-style-type: none"> <li>• Cisco Catalyst 9600 Series 56-Port 50G/25G/10G, 4-Port 100G (C9600X-LC-56YL4C): 56 SFP56 ports of 10G/25G/50G and 4 QSFP28 ports of 40G/100G<sup>1</sup></li> <li>• Cisco Catalyst 9600 Series 30-Port 100G/40G, 2-Port 400G/100G (C9600X-LC-32CD): 30 QSFP28 ports that support 100G/40G and 2 QSFP-DD ports that support 400G/100G/40G.</li> <li>• Cisco Catalyst 9600 Series 48-Port 1G (C9600-LC-48S): 48 ports that support SFP (48x1G ports).</li> <li>• Cisco Catalyst 9600 Series 48-Port 25G/10G/1G (C9600-LC-48YL): 48 SFP56 ports that support 1G/10G/25G.<sup>1</sup></li> <li>• Cisco Catalyst 9600 Series 24-Port 40G/1G/12-Port 100G (C9600-LC-24C): 24 QSFP28 ports of 40G/1G or 12 QSFP28 ports of 100G.</li> <li>• Cisco Catalyst 9600 Series 48-Port 10G/5G/2.5G/1G/100 Mbps/10 Mbps (C9600-LC-48TX): 48 Multigigabit Ethernet RJ45 copper ports that support 10G/5G/2.5G/1G/100 Mbps and 10 Mbps.</li> <li>• Cisco Catalyst 9600 Series 40-Port 50G, 2-Port 200G, 2-Port 400G (C9600-LC-40YL4CD): 40 SFP56 ports of 50G/25G/10G, two QSFP56 ports of 200G/100G/40G and two QSFP-DD ports of 400G/200G/100G/40G<sup>1</sup></li> </ul> <p>For more information about installing a line card, see the <i>Cisco Catalyst 9600 Series Line Card Installation Note</i>.</p>
Fan tray assembly	Provides a single front and rear serviceable and hot-swappable fan tray with 9 fans.
Power supplies	Has 4 power supply slots that supports up to 4 AC/DC power supply modules.
Backplane	Provides 6.4Tbps bandwidth per slot.



- Note** 1. For 1G speed, a maximum of eight SFP-1G-LH and/or SFP-1G-SX transceiver modules in SFP56 ports are supported per system



Figure 1: Front view of a Cisco Catalyst 9606R



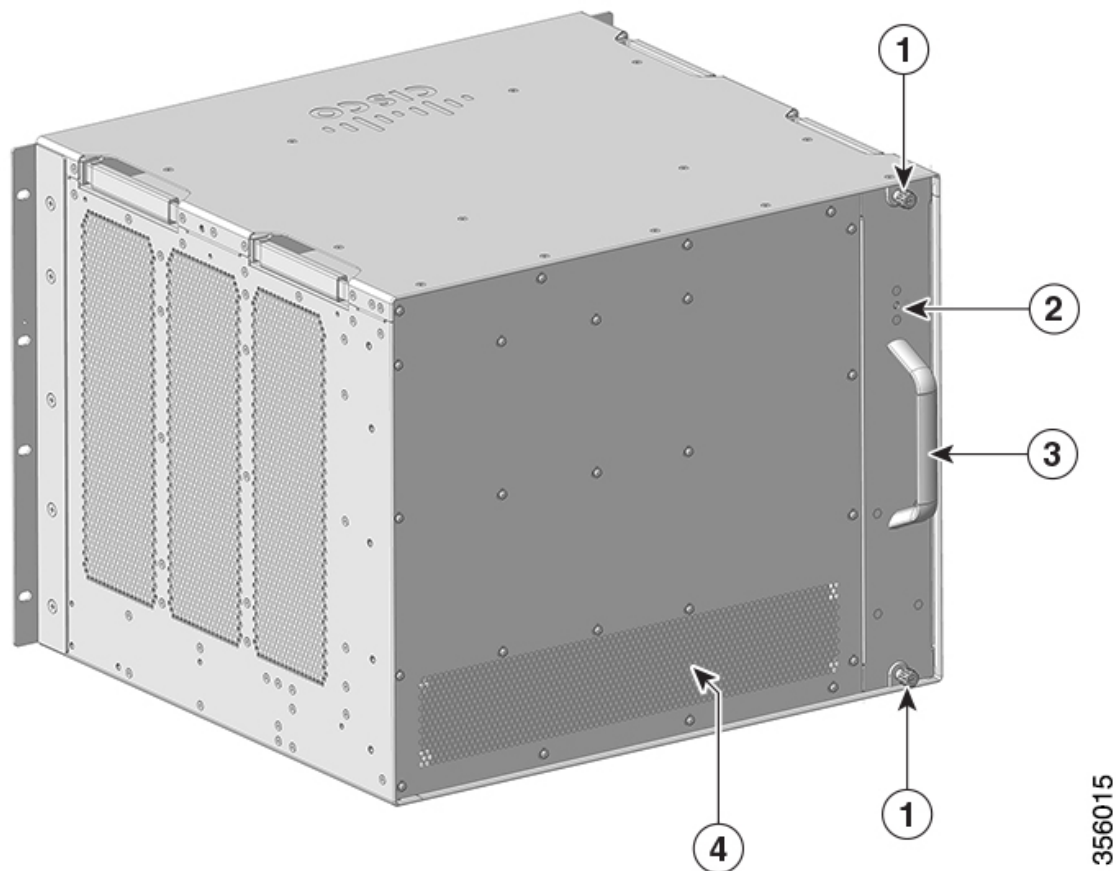
356000

1	Chassis handholds	5	Power switches
2	Chassis Radio Frequency ID (RFID)	6	System ground with ground lug screw holes on each side
3	Line card slots	7	Power Supply modules
4	Supervisor Module slots	8	Fan tray assembly

### Rear View of a Cisco Catalyst 9606R

The figure shows a rear view of the chassis, with the major components identified:

Figure 2: Rear View of a Cisco Catalyst 9606R



356015

1	Captive installation screws to remove the fan tray assembly.	3	Fan tray assembly handle
2	Blue beacon LED on the rear panel of the fan tray (always matches the blue beacon on the front panel of the fan tray)	4	Rear exhaust for the power supply modules

## Fan Tray Assembly

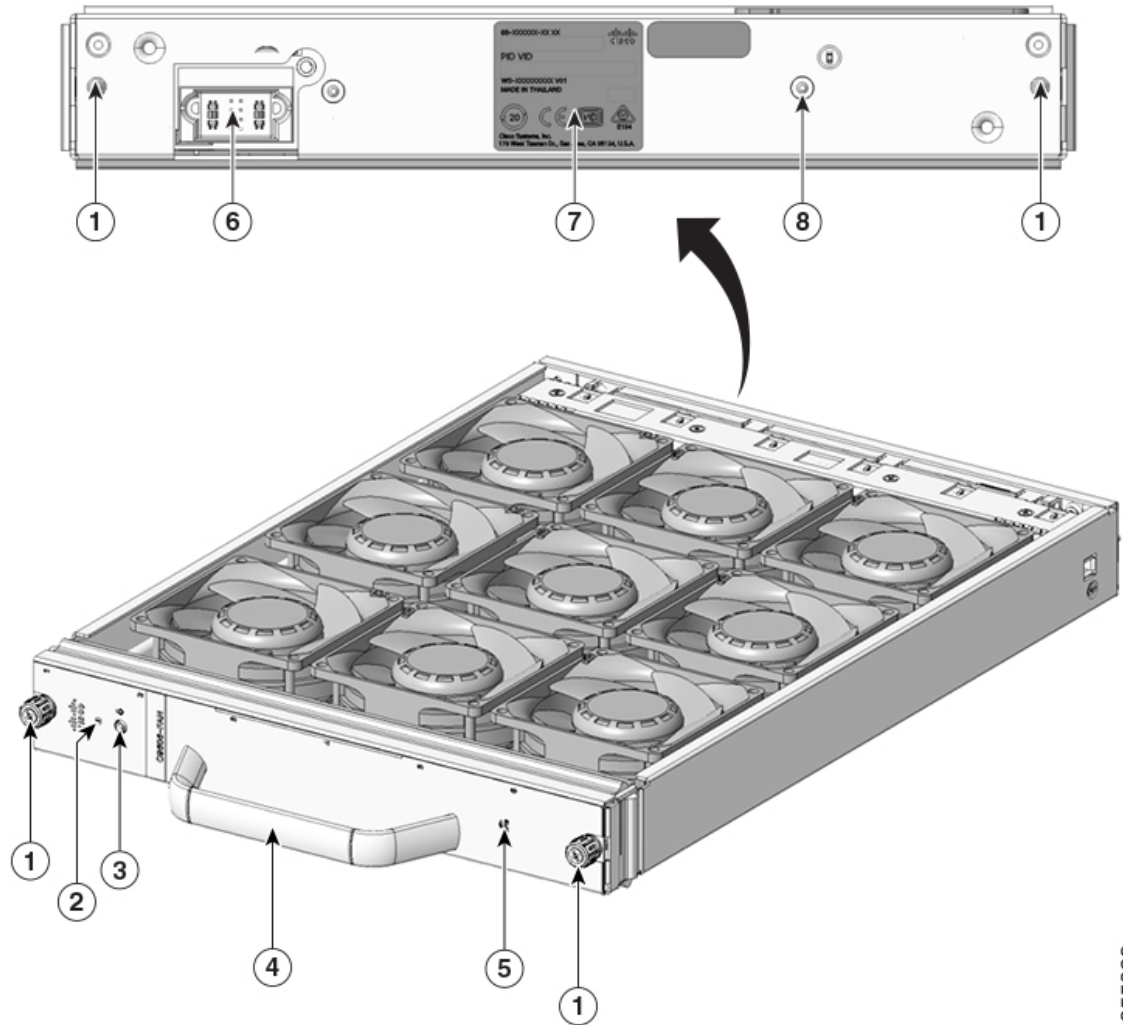
The fan tray assembly (C9606-FAN) in Cisco Catalyst 9600 Series Switches consists of a fan tray and a connector that is attached to the fan tray. It is responsible for cooling the entire chassis and interfacing with environmental monitors to trigger alarms when conditions exceed thresholds. The fan tray provides cooling that is critical for the switch operation which could otherwise result in a switch being non-operational or causing permanent damage to the modules or components.

The following lists the features and functionalities of a Cisco Catalyst 9600 fan tray:

- Has nine individual fans (three rows of three each) and supports a minimum airflow of 720 cubic feet per minute (cfm) at 100 percent fan throttle.
- Has side-to-side airflow for balanced airflow across the inserted cards. When facing the front of the chassis, airflow direction is right to left.
- You can install and remove from the front and the rear.
- Has a built-in, front-facing, passive RFID tag that uses Ultra High Frequency (UHF) RFID technology and requires an RFID reader with compatible software.
- Provides N+1 redundancy with individual fans. Fan tray does not support redundancy; however, with N+1 redundancy using individual fans, system ensures that there is no impact to the system performance even if one of the fans fails.
- Optimizes the fan-speed for temperature and pressure and maintains the minimum fan speeds and temperatures that the chassis requires, in ambient conditions.

The following figure shows C9606-FAN with the major components identified.

Figure 3: Fan Tray Assembly



355999

1	Captive installation screws on the front and the rear of the fan tray.	5	Fan tray RFID
2	Fan status LED	6	Fan tray connector
3	Switch to turn on the Blue Beacon LED.	7	Fan tray serial number
4	Front fan tray handle.	8	Blue beacon LED on the rear of the fan tray

## High Availability

To ensure high availability, the system is designed to respond to fan failures by either minimising impact or by compensating and operating at a worst case scenario specification.

- If a single fan fails, the remaining fans in the row compensate with increased speed.

- If two or more fans fail, the entire fan tray operates at full speed after one minute. Further, the fan tray must be replaced. The individual fans are not field replaceable, you must replace the fan tray.
- If the temperature sensor fails or communication with the temperature sensor fails, the worst case operating temperature is assumed.
- If the pressure sensor fails or communication with the pressure sensor fails, the worst case operating pressure is assumed.

## Thresholds, Alarms, and Abnormal Acoustic Conditions

Under normal operating conditions, when none of the temperature alarms have been triggered, hardware controls fan speed. If any of the system temperature alarms are triggered, software displays a syslog message indicating that the temperature is high, and the fans are operating at higher speed. Refer to the *System Management* section of the software configuration guide for more information.

In case of a fan failure, you must replace the fan tray within 120 seconds or power down the system. If the temperature exceeds the shutdown threshold, software powers the system down.

When the fan tray operates at full speed, increased noise levels may be expected. The fan tray may operate at full speed in these circumstances:

- If two or more fans have failed
- If the STATUS LED remains red for more than one minute
- If there is a hardware failure
- If the software watchdog timer is triggered

## Power Supply Module Overview

The switch chassis has four redundant power supply slots that operate with one to four power supply modules. The chassis supports field-replaceable AC-input and DC-input power supply modules.

The power supply modules generate 12Vdc output power and distributes it to the line cards and supervisor modules. The power supplies distribute power to all slots using an internal bus-bar based power distribution mechanism. All power supply modules have internal fans and support front-to-rear airflow.

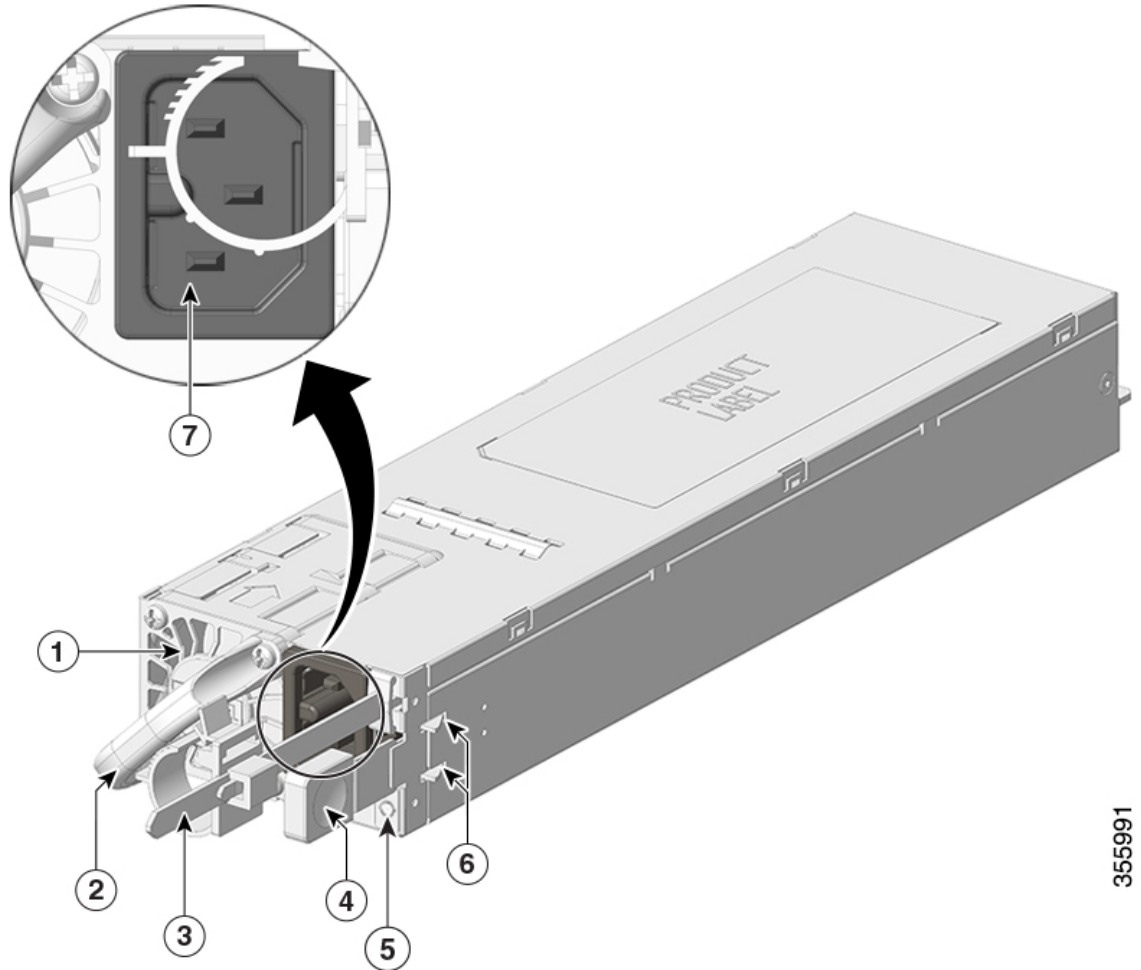
The following are the supported power supply modules:

**Table 2: Power Supply Modules Supported on Cisco Catalyst 9600 Series Switches**

Part Number	Description
C9600-PWR-2KWAC (=)	Cisco Catalyst 9600 Series 2000W AC Power Supply
C9600-PWR-2KWDC (=)	Cisco Catalyst 9600 Series 2000W DC Power Supply
C9600-PWR-3KWAC (=)	Cisco Catalyst 9600 Series 3000W AC Power Supply

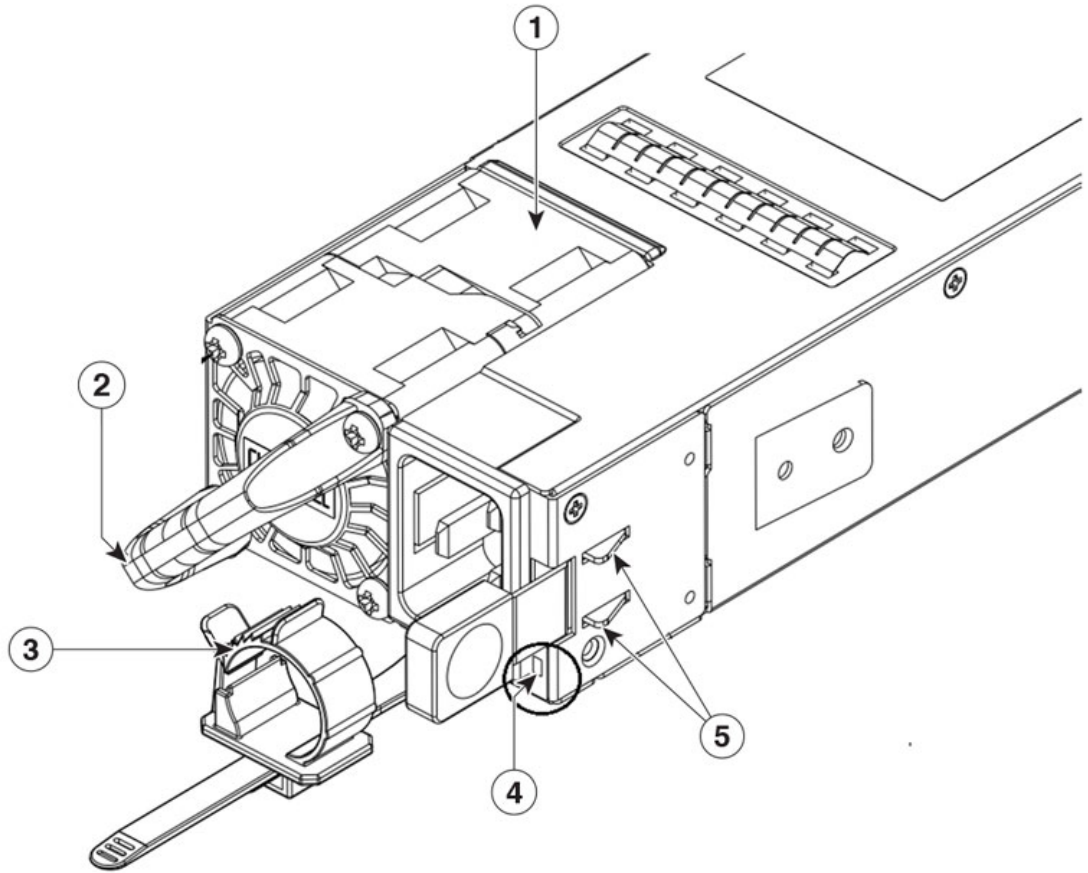
## AC Power Supply Module

Figure 4: Cisco Catalyst 9600 Series 2000W AC Power Supply



1	PSU fan	5	Status LED
2	Release handle	6	Retainer clips
3	Power cord retainer	7	Power cord connector
4	Release latch	-	-

Figure 5: Cisco Catalyst 9600 Series 3000W AC Power Supply



1	PSU fan	4	Status LED
2	Release handle	5	Latch shrapnel
3	Cable tie	-	-

The following are the features supported by a Cisco Catalyst 9600 Series AC power supply module:

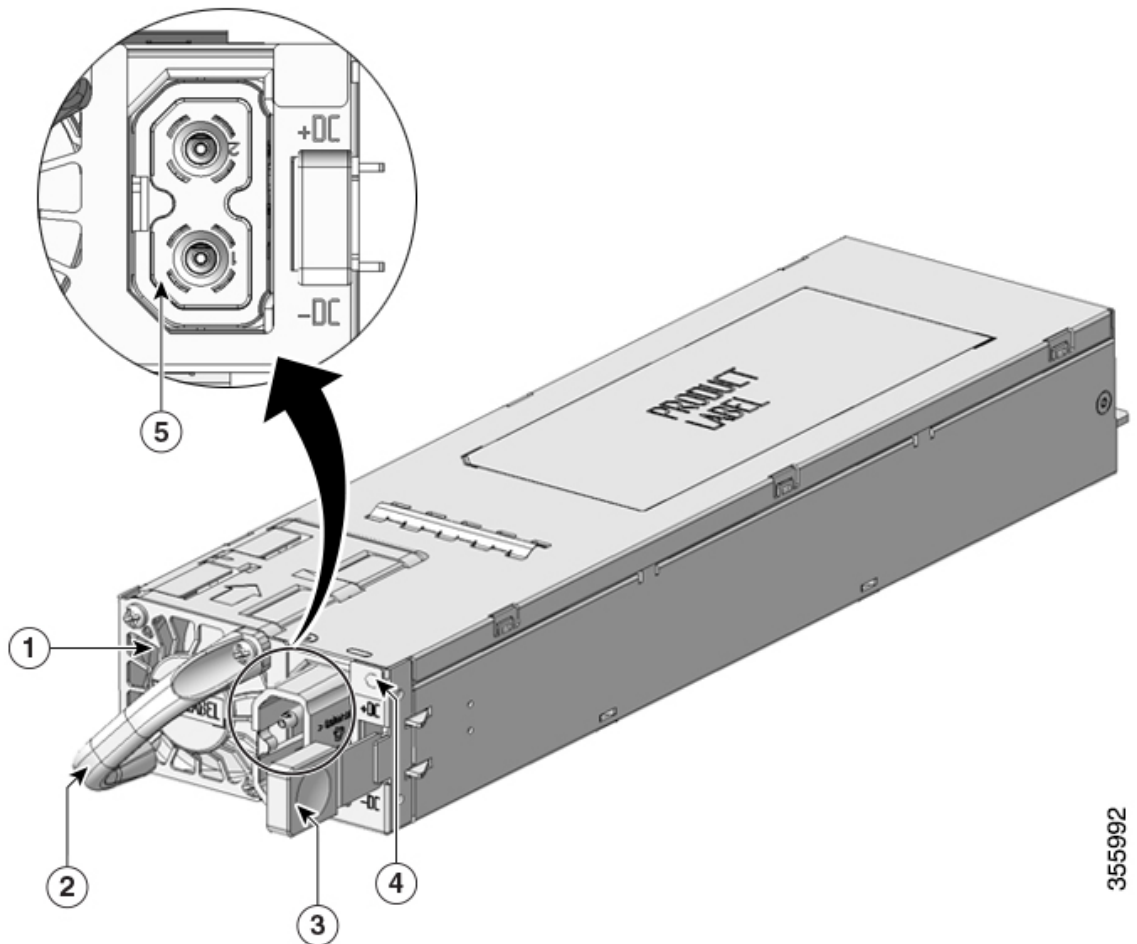
- Self-cooling, with a minimum airflow of 17 cubic feet per minute (CFM) at 100 percent load.
- Supports only single-phase source AC. Source AC can be out of phase between multiple power supplies or multiple AC-power plugs on the same power source because all AC power supply inputs are isolated.
- Has a release latch and cord-retention mechanism on the front panel of the module, to avoid accidental removal of the module or the attached power cord.
- Supports redundant and combined configuration modes. A single (non-redundant) or a dual (redundant) power supply configuration, can support the following loads:

Table 3: Output Power Capacity of AC PSUs at Different Input Voltage

PID	Input Voltage (VAC)	Output Power in Watts
C9600-PWR-2KWAC	110VAC	1050W
	220VAC	2000W
C9600-PWR-3KWAC	110VAC	1500W
	220VAC	3000W

## DC Power Supply Module

Figure 6: Cisco Catalyst 9600 Series 2000W DC Power Supply



355992

1	PSU fan	4	LED
2	Release handle	5	Power cord connector



3	Release latch	-	-
---	---------------	---	---

The following are the features supported by a Cisco Catalyst 9600 Series DC power supply module:

- Self-cooling, with a minimum airflow of 9.5 cubic feet per minute (CFM) at 100 percent load.
- Has a release latch mechanism on the side of the module, to avoid accidental removal of the module.
- Has DC-input reversal protection such that the unit will survive this condition up to the full input voltage rating.
- Supports redundant and combined configuration modes. A single (non-redundant) or a dual (redundant) power supply configuration, can support the following loads:

PID	Input Voltage (VDC)	Output Power
C9600-PWR-2KWDC	-40 to -72VDC (with extended range to -75VDC)	2000W

## Power Supply Modes

Cisco Catalyst 9600 Series Switches offer redundant and combined configuration modes for power supplies. In both the modes, the power supplies will share the load equally.

The number of power supply modules installed and the system load determine the power-level that the system expects to draw from each power supply module and consequently, the power supply mode that will be suitable. For system power budgeting estimates and to determine power supply requirements, use the [Cisco Power Calculator](#).

To configure a power supply mode, enter the **power redundancy-mode** command in global configuration mode. If you do not configure a mode, the default mode applies.

### Combined Mode

This is the default power supply mode.

The system operates with one to four power supply modules. The power available to the system is the sum of power outputs of all the power supply modules in the chassis multiplied by the share ratio. All available power supply modules are active and sharing power, and can operate at up to 100 percent capacity. Additional power supply units operate at 97 percent capacity. In combined mode, you can use a combination of AC and DC power supplies provided the AC input voltage is 220V and that the power supplies are of equal wattage. However, you cannot combine two AC power supplies of 110V input and 220V input.

Total combined mode power =  $P + (N-1) * P * (\text{share ratio})$

where P = Power output of one of the power supply units and N is the number of power supply modules used.



**Note** In case of failure in the combined mode, each operational power supply increases its output. If the output power does not meet system requirements, then all the operational power supply modules may be overloaded and go into overcurrent shutdown. All system power is then lost.

The following table provides details about the power output in combined mode:

**Table 4: Power Output in Combined Mode**

PID	Input voltage	One Power Supply	Two Power Supplies	Three Power Supplies	Four Power Supplies
C9600-PWR-2KWAC	110V	1050W	2040W	3030W	4020W
	220V	2000W	3940W	5880W	7820W
C9600-PWR-3KWAC	110V	1500W	2955W	4410W	5865W
	220V	3000W	5910W	8820W	11730W

### Redundant (N+1) Mode

In a redundant configuration, a given power supply module can either be active, or in standby mode. In N+1 redundant mode, N is the number of active power supply modules and +1 is the power supply module configured as the standby module.

You can configure redundancy mode in the software. When the switch is configured with N+1 redundancy, software ensures that there is a standby power supply available and there is sufficient power available with the active power supply modules (N). All the power supplies including active and standby will share the load equally. However, with a standby power supply installed, system ensures that the additional output power available with a standby is always reserved for use in case of a failure. If the power supply mode is set to redundant mode and the total active output power is not sufficient to meet the power requirements, the switch will not enter the redundant mode.

You can use a combination of AC and DC power supplies provided the AC input voltage is 220V and the power supplies must be of equal wattage. However, you cannot combine two AC power supplies of 110V input and 220V input.

The following table provides details about the power output in N+1 redundant mode:

**Table 5: Power Output in N+1 Redundant Mode**

PID	Input voltage	Two Power Supplies	Three Power Supplies	Four Power Supplies
C9600-PWR-2KWAC	110V	1050W	2040W	3030W
	220V	2000W	3940W	5880W
C9600-PWR-3KWAC	110V	1500W	2955W	4410W
	220V	3000W	5910W	8820W

For detailed software configuration information, see the required version of the *Software Configuration Guide*. In the guide, go to *Contents* → *System Management* → *Environmental Monitoring and Power Management*.



## CHAPTER 2

# Preparing for Installation

---

- [Safety Warnings, on page 13](#)
- [SFP and QSFP Module Ports, on page 17](#)
- [Site Requirements, on page 19](#)
- [Power Requirements, on page 30](#)
- [Cabling Requirements, on page 30](#)
- [Rack-Mounting Guidelines, on page 30](#)
- [Site Preparation Checklist, on page 32](#)

## Safety Warnings

Safety warnings appear throughout this publication in procedures that may harm you if you perform them incorrectly. A warning symbol precedes each warning statement. The warnings below are general warnings that are applicable to the entire publication.



---

**Warning** **Statement 1071**—Warning Definition

**IMPORTANT SAFETY INSTRUCTIONS**

Before you work on any equipment, be aware of the hazards involved with electrical circuitry and be familiar with standard practices for preventing accidents. Read the installation instructions before using, installing, or connecting the system to the power source. Use the statement number at the beginning of each warning statement to locate its translation in the translated safety warnings for this device.

SAVE THESE INSTRUCTIONS



**Note** **Statement 407**—Japanese Safety Instruction

You are strongly advised to read the safety instruction before using the product.

<https://www.cisco.com/web/JP/techdoc/pldoc/pldoc.html>

When installing the product, use the provided or designated connection cables/power cables/AC adapters.

〈製品仕様における安全上の注意〉  
www.cisco.com/web/JP/techdoc/index.html

接続ケーブル、電源コードセット、ACアダプタ、バッテリーなどの部品は、必ず添付品または指定品をご使用ください。添付品・指定品以外をご使用になると故障や動作不良、火災の原因となります。また、電源コードセットは弊社が指定する製品以外の電気機器には使用できないためご注意ください。



**Warning** To reduce the risk of electric shock, the chassis of this equipment needs to be connected to permanent earth ground during normal use. **Statement 0445**



**Warning** **Statement 1008**—Class 1 Laser Product

This product is a Class 1 laser product.



**Warning** **Statement 1017**—Restricted Area

This unit is intended for installation in restricted access areas. Only skilled, instructed, or qualified personnel can access a restricted access area.



**Warning** **Statement 1029**—Blank Faceplates and Cover Panels

Blank faceplates and cover panels serve three important functions: they reduce the risk of electric shock and fire, they contain electromagnetic interference (EMI) that might disrupt other equipment, and they direct the flow of cooling air through the chassis. Do not operate the system unless all cards, faceplates, front covers, and rear covers are in place.



**Warning** **Statement 1047**—Overheating Prevention

To prevent the system from overheating, do not operate it in an area that exceeds the maximum recommended ambient temperature of 104°F (40°C).



**Warning** **Statement 1049**—Rack Installation

To reduce the risk of bodily injury, mount the chassis on a rack that is permanently affixed to the building.

**Warning Statement 1055**—Class 1/1M Laser

Invisible laser radiation is present. Do not expose to users of telescopic optics. This applies to Class 1/1M laser products.

**Warning Statement 1056**—Unterminated Fiber Cable

Invisible laser radiation may be emitted from the end of the unterminated fiber cable or connector. Do not view directly with optical instruments. Viewing the laser output with certain optical instruments, for example, eye loupes, magnifiers, and microscopes, within a distance of 100 mm, may pose an eye hazard.

**Warning Statement 1090**—Installation by Skilled Person

Only a skilled person should be allowed to install, replace, or service this equipment. See statement 1089 for the definition of a skilled person.

There are no serviceable parts inside. To avoid risk of electric shock, do not open.

**Warning Statement 1074**—Comply with Local and National Electrical Codes

To reduce risk of electric shock or fire, installation of the equipment must comply with local and national electrical codes.

**Warning Statement 1089**—Instructed and Skilled Person Definitions

An instructed person is someone who has been instructed and trained by a skilled person and takes the necessary precautions when working with equipment.

A skilled person or qualified personnel is someone who has training or experience in the equipment technology and understands potential hazards when working with equipment.

There are no serviceable parts inside. To avoid risk of electric shock, do not open.

**Warning Statement 1091**—Installation by an Instructed Person

Only an instructed person or skilled person should be allowed to install, replace, or service this equipment. See statement 1089 for the definition of an instructed or skilled person.

There are no serviceable parts inside. To avoid risk of electric shock, do not open.



---

**Warning Statement 1099**—Before Connecting to System Power Supply

High touch/leakage current—Permanently connected protective earth ground is essential before connecting to the system power supply.

---



---

**Warning Statement 9001**—Product Disposal

Ultimate disposal of this product should be handled according to all national laws and regulations.

---

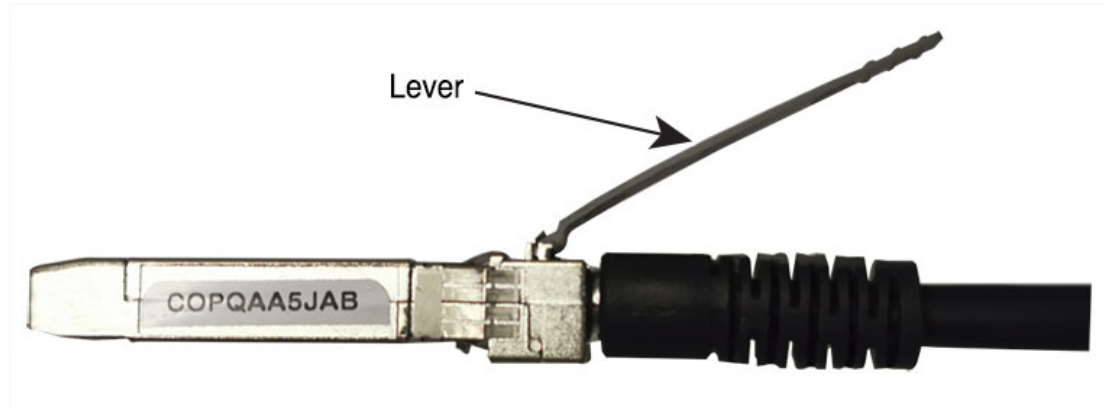
# SFP and QSFP Module Ports



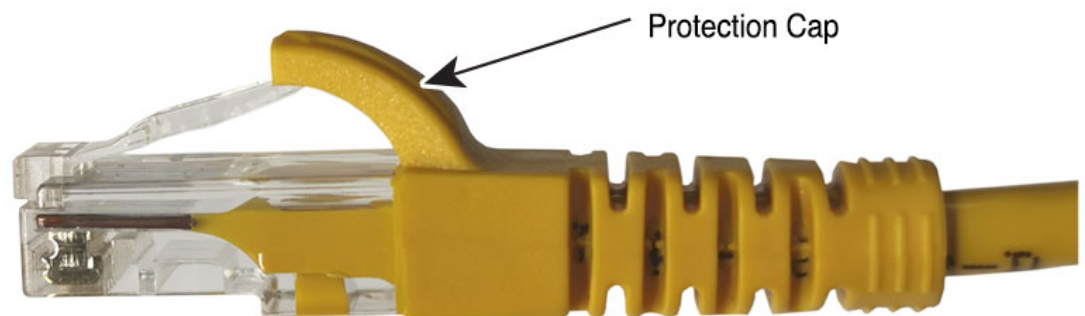
Note

With the C9600X-LC-56YL4C model:

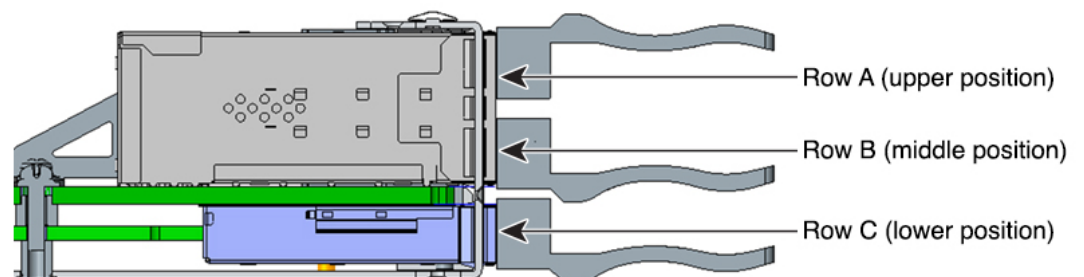
- Do not use the SFP-H10GB-CUXX (1M/1.5M/2M/2.5M/3M/5M), SFP-H10GB-ACUXX (7M/10M) and SFP-10G-AOCXX (1M/2M/3M/5M/7M/10M) types of SFP modules from TE Connectivity, because the lever on these modules might interfere with other parts of the switch.



- On an SFP-10G-T-X SFP module, do not use an RJ-45 cable with a protection cap because the protruding cap might interfere with other parts of the switch.



- Do not use the SFP-25G-SR-S, SFP-10/25G-LR-S, SFP-10/25G-CSR-S on row C, the SFP module will be removed from the SFP port, if the lower card (underneath this card) is removed from the chassis of C9600.





# Site Requirements

Planning a proper location for the switch and layout of the equipment rack or wiring closet is essential for successful system operation. These sections describe some of the basic site requirements that you should be aware of as you prepare to install your switch, including the following:

- Environmental factors can adversely affect the performance and longevity of your system.
- Install the switch in an enclosed, secure area, ensuring that only qualified personnel have access to the switch and control of the environment.
- Equipment that is placed too closely together or that is inadequately ventilated may cause system over-temperature conditions, leading to premature component failure.
- Poor equipment placement can make chassis panels inaccessible and difficult to maintain.
- The switch requires a dry, clean, well-ventilated, and air-conditioned environment.
- To ensure normal operation, maintain ambient airflow. If the airflow is blocked or restricted, or if the intake air is too warm, an over-temperature condition may occur. The switch environmental monitor may then shut down the system to protect the system components.
- Multiple switches can be rack mounted with little or no clearance above and below the chassis. However, when mounting a switch in a rack with other equipment, or when placing it on the floor near other equipment, ensure that the exhaust from other equipment does not blow into the air intake vent of the switch chassis.

## Temperature

Temperature extremes may cause a system to operate at reduced efficiency and cause a variety of problems, including premature aging and failure of chips, and failure of mechanical devices. Extreme temperature fluctuations may also cause chips to become loose in their sockets. Observe the following guidelines:

- Ensure that the system is operating in an environment that is:
  - 23 to 104 °F (-5 to 40 °C) up to 6000 feet (1800m)
  - 23 to 104 °F (-5 to 40 °C) up to 10000 feet (3000m)
- Ensure that the chassis has adequate ventilation.
- Do not place the chassis within a closed-in wall unit or on top of cloth, which can act as thermal insulation.
- Do not place the chassis where it will receive direct sunlight, particularly in the afternoon.
- Do not place the chassis next to a heat source of any kind, including heating vents.
- Adequate ventilation is particularly important at high altitudes. Make sure that all the slots and openings on the system remain unobstructed, especially the fan vent on the chassis.
- Clean the installation site at regular intervals to avoid buildup of dust and debris, which may cause a system to overheat.
- If system is exposed to abnormally low temperatures, allow a two hour warm up period, in ambient temperature no lower than 32°F (0 °C) before turning on.



---

**Caution** You have 2 minutes to replace fan tray. If one fans in the fan tray is not functioning, the system can function; however, you must replace the fan tray as soon as possible.

---

Failure to observe these guidelines may damage the chassis' internal components.

## Air Flow

The switch is designed to be installed in an environment where there is a sufficient volume of air available to cool the supervisor engines, modules, and power supplies. If there are any constraints with regard to the free flow of air through the chassis, or if the ambient air temperature is elevated, the switch environmental monitor may then shut down the system to protect the system components.

To maintain proper air circulation through the switch chassis, we recommend that you maintain a minimum space of 6 inches (15 cm) between a wall and the chassis and power supply unit air intakes or a wall and the chassis and power supply unit hot air exhausts. In situations where the switch chassis are installed in adjacent racks, you should allow a minimum space of 12 inches (30.5 cm) between the air intake of one chassis and the hot air exhaust of another chassis.

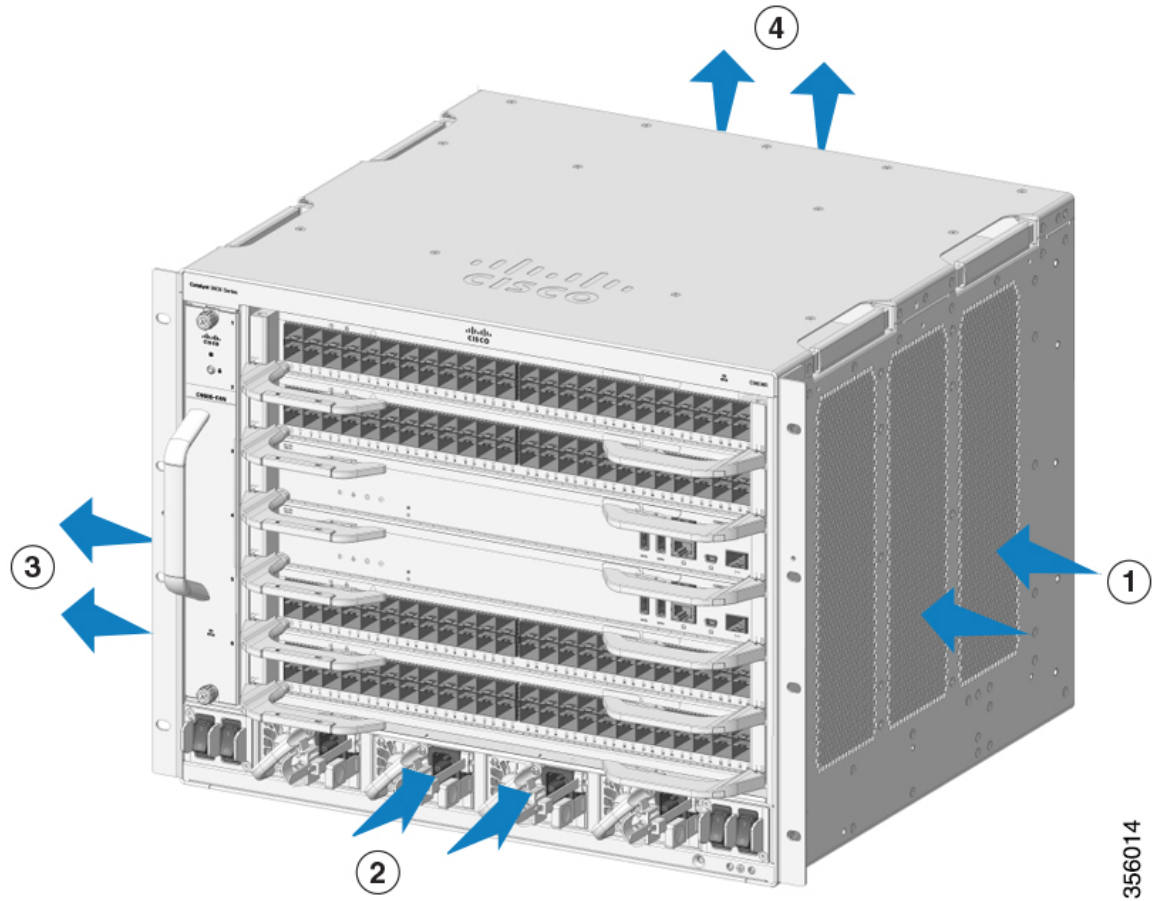


---

**Note** Failure to maintain adequate spacing between chassis may cause the switch chassis that is drawing in the hot exhaust air to overheat and fail.

---

Figure 7: Air Flow Direction - Cisco Catalyst 9600 Series Switches



1	Chassis air intake	3	Chassis air exhaust
2	Power supply air intake	4	Power supply air exhaust

If you are installing your switch in an enclosed or partially enclosed rack, we strongly recommend that you verify that your site meets the following guidelines:

- Verify that there is a minimum of 6 inches (15 cm) of clearance between the sides, front, and back of any enclosure, and both the chassis air intake grill and the chassis air exhaust grill along with the power supply unit intakes and exhausts. The upright columns of a relay rack may be located less than the recommended side spacing provided there are substantial cutouts, holes, or vents in the structure to allow adequate air flow through the chassis.
- Verify that the ambient air temperature within the enclosed or partially enclosed rack is within the chassis operating temperature limits. After installing the chassis in the rack, power up the chassis and allow the chassis temperature to stabilize (approximately 2 hours).

Measure the ambient air temperature at the chassis air intake grill by positioning an external temperature probe 1 inch (2.5 cm) away from the chassis left side, and centered on the chassis both horizontally and vertically.

Measure the ambient air temperature at the power supply unit air intake grill by positioning an external temperature probe 1 inch (2.5 cm) away from the chassis front, centered on the power supply unit section located above the card slots.

- If the ambient intake air temperature is less than 113°F (45°C) at altitudes of 6,000 feet and below, the rack meets the intake air temperature criterion. At altitudes above that threshold and up to 10,000 feet (3000 m), the air intake should not exceed 104°F (40°C).
- If the ambient intake air temperature exceeds this recommendation, the system may experience minor temperature alarms and increase fan speeds in response.
- If the ambient intake air temperature equals or is greater than 131°F (55°C), the system may experience a major temperature alarm with maximum fan speeds in response. If ambient temperature continues to increase, system will respond with protective shut down.
- Plan ahead. A switch that is currently installed in an enclosed or partially enclosed rack might meet ambient air temperature and air flow requirements at present. However, if you add more chassis to the rack or more modules to a chassis in the rack, the additional heat generated might cause the ambient air temperature at the chassis or power supply unit inlets to exceed recommended conditions which may trigger thermal alarms.

## Humidity

High-humidity conditions may cause moisture to enter the system, and cause corrosion of internal components and degradation of properties such as electrical resistance, thermal conductivity, physical strength, and size. Extreme moisture buildup inside the system may result in electrical short circuit, which may cause serious damage to the system. Each system is rated for storage and operation in 10 to 95 percent relative humidity, non-condensing with a humidity gradation of 10 percent per hour. Buildings in which climate is controlled by air-conditioning in the warmer months and by heat during the colder months usually maintain an acceptable level of humidity for system equipment. However, if a system is located in an unusually humid location, a dehumidifier should be used to maintain the humidity within an acceptable range.

## Altitude

Operating a system at high altitude (low pressure) reduces the efficiency of forced and convection cooling and may result in electrical problems related to arcing and corona effects. This condition may also cause sealed components with internal pressure, such as electrolytic capacitors, to fail or perform at reduced efficiency.

## Dust and Particles

Fans cool power supplies and system components by drawing in room-temperature air and exhausting heated air out through various openings in the chassis. However, fans also ingest dust and other particles, causing contaminant buildup in the system and increased internal chassis temperature. A clean operating environment can greatly reduce the negative effects of dust and other particles, which act as insulators and interfere with the mechanical components in the system.

The standards listed below provide guidelines for acceptable working environments and acceptable levels of suspended particulate matter:

- National Electrical Manufacturers Association (NEMA) Type 1

- International Electrotechnical Commission (IEC) IP-20

## Air Quality

Dust is everywhere and often invisible to the naked eye. It consists of fine particles in the air that originate from various sources, such as soil dust lifted by weather, from volcanic eruptions, or pollution. Dust at an installation site may contain small amounts of textile, paper fibers, or minerals from outdoor soil. It may also contain natural contaminants, such as chlorine from the marine environment and industrial contaminants such as sulfur. Ionized dust and debris are dangerous and get attracted to electronic equipment.

The accumulation of dust and debris on electronic equipment has the following adverse effects:

- It increases the operating temperature of the equipment. According to the Arrhenius effect, an increase in the operating temperature leads to a decrease in reliability and life of the equipment.
- The moisture and corrosive elements that are present in the dust can corrode the electronic or mechanical components and cause premature board failure.

These adverse effects are further accelerated by the presence of fans in the data networking equipment that ingest dust and other particles into the equipment. Higher the volume of air that is generated by the fans for cooling, the higher the quantity of dust and particulates that get deposited and trapped inside the equipment. Remove or minimize the presence of dust and particulates at the installation site by following the guidelines mentioned in ANSI 71-04-2013 regulations.



---

**Note** In addition to the guidelines mentioned in ANSI 71-04-2013 regulations, follow all applicable guidelines as per site conditions to remove or minimize other contaminants.

---

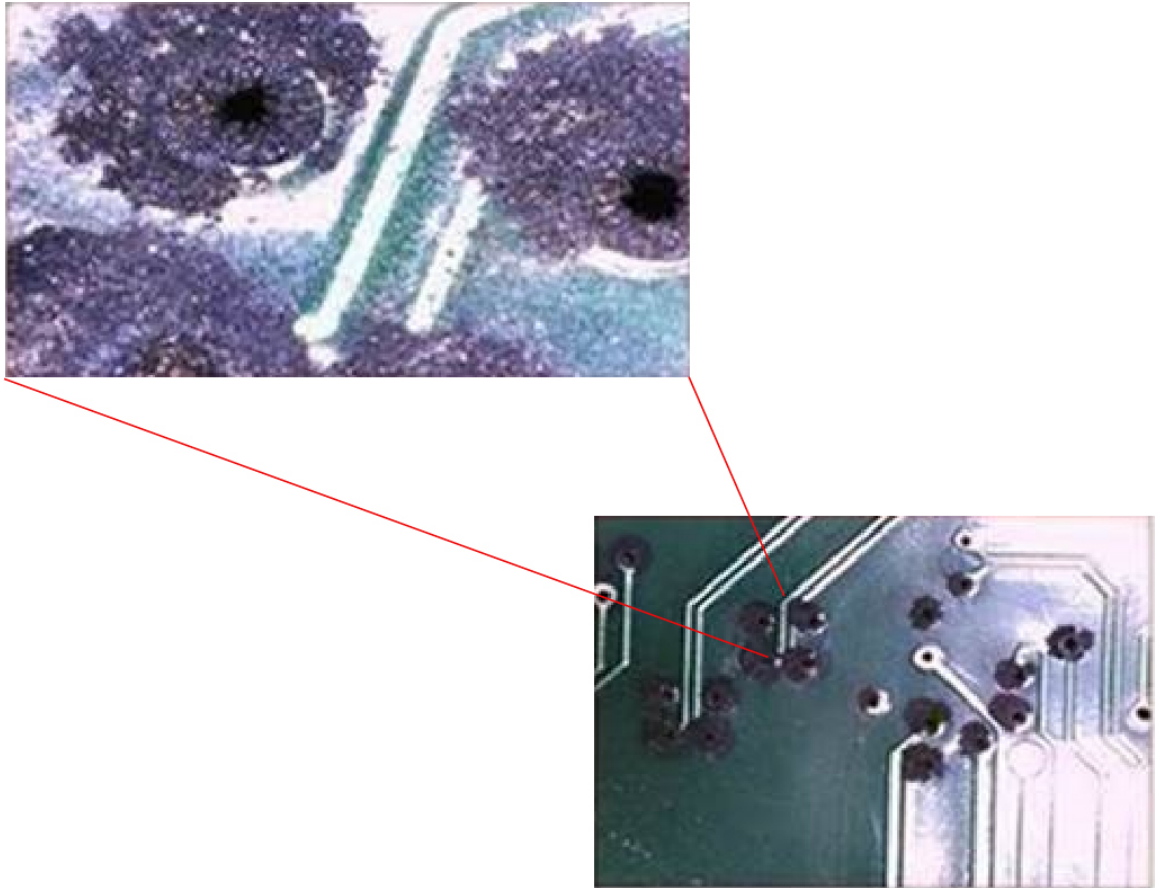
## Corrosion

Corrosion is a chemical reaction that occurs between electronic components and gases which results in metal deterioration. Corrosion attacks edge connectors, pin connectors, IC plug-in sockets, wirewraps, and all other metal components. Depending on the type and concentration level of the corrosive gases, performance degradation of the components occurs either rapidly or over a period of time. It also leads to blocked currents, brittle connection points, and overheated electrical systems. Corrosion by-products form insulating layers on circuits and causes electronic failure, short circuits, pitting, and metal loss.

A type of corrosion known as creep corrosion, that primarily affects PCBA (Printed Circuit Board Assembly) occurs when the PCBA is subjected to a harsh, and sulfur-rich (hydrogen sulfide) end-use environment over a prolonged period of time. The corrosion begins on certain exposed metals, such as copper and silver, and then creeps along the remaining metal surface either causing electrical short circuits or creating holes. Creep corrosion also occurs on electronic components such as resistors and PCBs.

To prevent corrosion, remove or minimize the presence of dust and particulates at the installation site by following the guidelines mentioned in ANSI 71-04-2013 regulations.

*Figure 8: A PCB with Corrosion on its Metal Contacts*



## EMI and Radio Frequency Interference

Electro-Magnetic interference (EMI) and radio frequency interference (RFI) from a system can adversely affect devices such as radio and television (TV) receivers operating near the system. Radio frequencies emanating from a system can also interfere with cordless and low-power telephones. Conversely, RFI from high-power telephones can cause spurious characters to appear on the system monitor. RFI is defined as any EMI with a frequency above 10 kilohertz (kHz). This type of interference can travel from the system to other devices through the power cable and power source, or through the air in the form of transmitted radio waves. The Federal Communications Commission (FCC) publishes specific regulations to limit the amount of harmful interference emitted by computing equipment. Each system meets these FCC regulations. To reduce the possibility of EMI and RFI, follow these guidelines:

- Always operate the system with the chassis covers installed.
- Ensure that all chassis slots are covered by a metal filler bracket and that an unused power supply bay has a metal cover plate installed.
- Ensure that the screws on all peripheral cable connectors are securely fastened to their corresponding connectors on the back of the chassis.
- Always use shielded cables with metal connector shells for attaching peripherals to the system.

When wires are run for any significant distance in an electromagnetic field, interference can occur between the field and the signals on the wires. This fact has two implications for the construction of plant wiring:

- Bad wiring practice can result in radio interference emanating from the plant wiring.
- Strong EMI, especially when it is caused by lightning or radio transmitters, can destroy the signal drivers and receivers in the chassis, and even create an electrical hazard by conducting power surges through lines into equipment.



---

**Note** To predict and provide a remedy for strong EMI, consult experts in RFI.

---

If you use twisted-pair cable in your plant wiring, include a good distribution of grounding conductors to reduce EMI. If you exceed the recommended distances, use a high-quality twisted-pair cable with one ground conductor for each data signal when applicable.



---

**Caution** Category 5e, Category 6, and Category 6a cables can store large levels of static electricity because of the dielectric properties of the materials used in their construction. Always ground the cables (especially in new cable runs) to a suitable and safe earth ground before connecting them to the module.

---

If the wires exceed the recommended distances, or if wires pass between buildings, give special consideration to the effect of a lightning strike in your vicinity. The electromagnetic pulse caused by lightning or other high-energy phenomena can easily couple enough energy into unshielded conductors to destroy electronic devices. If you have had problems of this sort in the past, you may want to consult experts in electrical surge suppression and shielding.



---

**Caution** The intra-building ports (Copper-Based Ethernet Ports) of the equipment or subassembly is suitable for connection to inside a building or unexposed wiring or cabling only. If the intra-building ports of the equipment or subassembly is metallically connected to interfaces that connect to the Out Side Plant (OSP) or its wiring, the metallic-connection **MUST NOT** be more than 6 meters (approximately 20 feet). These interfaces are designed for use as intra-building interfaces only (Type 2, 4, or 4a ports as described in GR-1089-CORE) and require isolation from the exposed OSP cabling. The addition of Primary Protectors is not sufficient protection in order to connect these interfaces metallically to an OSP wiring system.

---

## Shock and Vibration

The equipment complies with the Earthquake, Office, and Transportation Vibration, and Equipment Handling Criteria of GR-63-CORE.

## Power Source Interruptions

Systems are especially sensitive to variations in voltage supplied by the AC power source. Overvoltage, undervoltage, and transients (or spikes) can erase data from memory or even cause components to fail. To protect against these types of problems, power wiring ground conductors should always be properly grounded. Also, place the system on a dedicated power circuit (rather than sharing a circuit with other heavy electrical equipment). In general, do not allow the system to share a circuit with any of the following:

- Copy machines
- Air conditioners
- Vacuum cleaners
- Space heaters
- Power tools
- Teletype machines
- Laser printers
- Facsimile machines
- Any other motorized equipment

Besides these appliances, the greatest threats to a system's power supply are surges or blackouts that are caused by electrical storms. Whenever possible, turn off the system and peripherals, if any, and unplug them from their power sources during thunderstorms. If a blackout occurs—even a temporary one—while the system is turned on, turn off the system immediately and disconnect it from the electrical outlet. Leaving the system on may cause problems when the power is restored; all other appliances left on in the area may create large voltage spikes that may damage the system.

## System Grounding



---

### **Warning** Statement 1046—Installing or Replacing the Unit

To reduce risk of electric shock, when installing or replacing the unit, the ground connection must always be made first and disconnected last.

If your unit has modules, secure them with the provided screws.

---

You must install a system ground as part of the chassis installation process. Chassis installations that rely only on the AC third-prong ground are insufficient to adequately ground the systems.

Proper grounding practices ensure that the buildings and the installed equipment within them have low-impedance connections and low-voltage differentials between chassis. When you install a system ground, you reduce or prevent shock hazards, chances of equipment damage due to transients, and the potential for data corruption.

Without proper and complete system grounding, you run the risk of increased component damage due to ESD. Additionally, you have a greatly increased chance of data corruption, system lockup, and frequent system reboot situations by not using a system ground.



---

**Caution** Installations that rely solely on system grounding that uses only an AC third-prong ground run a substantially greater risk of equipment problems and data corruption than those installations that use both the AC third-prong ground and a properly installed system ground.

---

The following table lists some general grounding practice guidelines.



**Table 6: Grounding Practice Guidelines**

Environment	Electromagnetic Noise Severity Level	Grounding Recommendations
<p>Commercial building is subjected to direct lightning strikes.</p> <p>For example, some places in the United States, such as Florida, are prone to more lightning strikes than other areas.</p>	High	<p>All lightning protection devices must be installed in strict accordance with manufacturer recommendations.</p> <p>Conductors carrying lightning current should be spaced away from power and data lines in accordance with applicable recommendations and building codes. Best grounding practices must be closely followed.</p>
<p>Commercial building is located in an area where lightning storms occur frequently, but is not prone to direct lightning strikes.</p>	High	<p>Best grounding practices must be closely followed.</p>
<p>Commercial building contains a mix of information technology equipment and industrial equipment, such as welding.</p>	Medium to High	<p>Best grounding practices must be closely followed.</p>
<p>Existing commercial building is not subject to natural environmental noise or man-made industrial noise. This building contains a standard office environment. This installation has a history of malfunction due to electromagnetic noise.</p>	Medium	<p>Best grounding practices must be closely followed. Determine source and cause of noise if possible, and mitigate as closely as possible at the noise source or reduce coupling from the noise source to the victim equipment.</p>
<p>New commercial building is not subject to natural environmental noise or man-made industrial noise. This building contains a standard office environment.</p>	Low	<p>Best grounding practices should be followed as closely as possible. Electromagnetic noise problems are not anticipated, but installing a best-practice grounding system in a new building is often the least expensive route, and the best way to plan for the future.</p>
<p>Existing commercial building is not subject to natural environmental noise or man-made industrial noise. This building contains a standard office environment.</p>	Low	<p>Best grounding practices should be followed as much as possible. Electromagnetic noise problems are not anticipated, but installing a best-practice grounding system is always recommended.</p>



---

**Note** In all situations, grounding practices must comply with Section 250 of the National Electric Code (NEC) requirements or local laws and regulations. A 6 AWG grounding wire is preferred from the chassis to the rack ground or directly to the common bonding network (CBN). The equipment rack should also be connected to the CBN with a 6 AWG grounding wire.

---



---

**Note** Grounding lugs must be installed on the location marked on the chassis only.

---



---

**Note** Always ensure that all of the modules are completely installed and that the captive installation screws are fully tightened. In addition, ensure that all the I/O cables and power cords are properly seated. These practices are normal installation practices and must be followed in all installations.

---



---

**Caution** Category 5e, Category 6, and Category 6a cables can store large levels of static electricity because of the dielectric properties of the materials used in their construction. Always ground the cables (especially in new cable runs) to a suitable and safe earth ground before connecting them to the module.

---

## Maintaining Safety with Electricity

When working on electrical equipment, follow these guidelines:

- Do not work alone if potentially hazardous conditions exist anywhere in your work space.
- Never assume that power is disconnected from a circuit; always check the circuit before working on it.
- When the power is switched off, put a lock-box on the circuit, so that no one can accidentally switch it on.
- Look carefully for possible hazards in your work area, such as damp floors, ungrounded power extension cables, frayed or damaged power cords, and missing safety grounds.
- If an electrical accident occurs, proceed as follows:
  - Use extreme caution; do not become a victim yourself.
  - Disconnect power from the system.
  - Seek medical attention, if necessary.
- Use the product within its marked electrical ratings and product usage instructions.
- Install the product in compliance with local and national electrical codes.
- If any of the following conditions occur, contact the Cisco Technical Assistance Center:
  - The power cable or plug is damaged.
  - An object has fallen into the product.

- The product has been exposed to water or other liquids.
  - The product has been dropped or shows signs of damage.
  - The product does not operate correctly when you follow the operating instructions.
- Use the correct external power source. Operate the product only from the type of power source indicated on the electrical ratings label. If you are not sure of the type of power source required, consult a local electrician.
  - Use approved power cables only. You have been provided with one or more power cables with your chassis power supply that are intended for use in your country, based on the shipping location. Should you need to purchase additional power cables, ensure that they are rated for the product and for the voltage and current marked on the product's electrical ratings label. The voltage and current rating of the power cable should be greater than the ratings marked on the label.
  - To help prevent electrical shock, plug all the power cables into properly grounded electrical outlets. These power cables are equipped with three-prong plugs to ensure proper grounding. Do not use adapter plugs or remove the grounding prong from a power cable.
  - Observe power strip ratings. Make sure that the total current rating of all products that are plugged into the power strip does not exceed 80 percent of the power strip rating.
  - Do not modify power cables or plugs yourself. Consult with a licensed electrician or your power company for site modifications. Always follow your local and national wiring codes.

## Preventing ESD Damage

ESD damage might occur when modules or other FRUs are improperly handled, resulting in intermittent or complete failure of the modules or FRUs. Modules consist of printed circuit boards that are fixed in metal carriers. EMI shielding and connectors are integral components of a carrier. Although the metal carrier helps to protect the board from ESD, always use an ESD-grounding strap when handling modules. To prevent ESD damage, follow these guidelines:

- Always use an ESD wrist or ankle strap and ensure that it makes good skin contact.
- Connect the equipment end of the strap to an unfinished chassis surface.
- When installing a component, use an available ejector lever to properly seat the bus connectors in the backplane or midplane. These devices prevent accidental removal, provide proper grounding for the system, and help to ensure that bus connectors are properly seated.
- When removing a component, use an available ejector lever to release the bus connectors from the backplane or midplane.
- Handle carriers by available handles or edges only; avoid touching the printed circuit boards or connectors.
- Place a removed component board-side-up on an antistatic surface or in a static-shielding container. If you plan to return the component to the factory, immediately place it in a static-shielding container.
- Avoid contact between the printed circuit boards and clothing. The wrist strap only protects components from ESD voltages on the body; ESD voltages on clothing can still cause damage.
- Never attempt to remove the printed circuit board from the metal carrier.

# Power Requirements

Power supplies installed on the switch chassis can be all AC-input, all DC-input, or a mix of both. When preparing your site for switch installation, adhere to these requirements:

- In systems configured with more than one power supply, connect each of the power supplies to a separate input power source. If you fail to do this, your system might be susceptible to total power failure due to a fault in the external wiring or a tripped circuit breaker
- To prevent loss of input power, be sure that the total maximum load on each source circuit is within the current ratings of the wiring and breakers.
- In some systems, you may decide to use an uninterruptible power supply (UPS) to protect against power failures at your site. Be aware when selecting a UPS that some UPS models that use ferroresonant technology may become unstable when operating with the switch power supplies that use power factor correction. This may cause the output voltage waveform to the switch to become distorted, resulting in an undervoltage situation in the system.

# Cabling Requirements

When running power and data cables together in overhead cable trays or subfloor cable trays, be aware of the following caution:

**Caution**

We strongly recommend that power cabling runs and other potential noise sources be located as far away as practical from LAN cabling that terminates on Cisco equipment. In situations where this type of long parallel cable runs exist and cannot be separated by at least 3.3 feet (1 meter), we recommend that you shield these potential noise sources. To avoid interference, the source should be shielded by housing it in a grounded metallic conduit.

Also be aware of the following caution concerning the use of Category 5e and Category 6 Ethernet cables:

**Caution**

Category 5e, Category 6, and Category 6a cables can store large levels of static electricity because of the dielectric properties of the materials used in their construction. Always ground the cables (especially in new cable runs) to a suitable and safe earth ground before connecting them to the module.

# Rack-Mounting Guidelines

## Rack Specifications

Cisco Catalyst 9600 Series Switches are designed to be installed in standard, 19-inch equipment racks that meet EIA-310-D specifications. In Network Equipment Building Systems (NEBS) compliant installation, you can use only a 23-inch rack mount. Before rack-mounting the chassis, ensure that the equipment rack complies with all requirements and guidelines

### Mounting Location Guidelines

Cisco Catalyst 9600 Series Switches must be front-mounted.

Accordingly, you can install the chassis in 2-post or 4-post racks, but in a 4-post rack, the rear posts are not used for mounting.

### Width and Depth Requirements

Use a tape measure to verify the interior dimensions of the rack.

- Measure the space between the inner edges of the left front and right front mounting posts. The chassis is 19 inches (48.26 cm) wide and must fit between the mounting posts.
- Measure the depth of the rack from the outside of the front mounting posts to the outside of the rear mounting strip. The chassis is 18.8 inches (47.75 cm) deep.

### Height Requirements

The rack must have sufficient clearance in terms of height, to insert the chassis. Chassis height is also measured in rack units (RU or just U) where 1 RU or 1 U equals 1.75 inches (44.45 mm). A typical server rack is 42 RU or 42 U in height.

The chassis height of Catalyst 9606R Switch is 8 RU with a depth of 18.8 inches.

### Other General Guidelines



---

**Caution** If the equipment rack is on wheels, ensure that the brakes are engaged and that the rack is stabilized.

---



---

**Warning** To prevent bodily injury when mounting or servicing this unit in a rack, you must take special precautions to ensure that the system remains stable. The following guidelines are provided to ensure your safety:

- This unit should be mounted at the bottom of the rack if it is the only unit in the rack.
- When mounting this unit in a partially filled rack, load the rack from the bottom to the top with the heaviest component at the bottom of the rack.
- If the rack is provided with stabilizing devices, install the stabilizers before mounting or servicing the unit in the rack. **Statement 1006**

---



---

**Warning** Take care when connecting units to the supply circuit so that wiring is not overloaded. **Statement 1018**

---



**Note** To maintain proper air circulation through the switch chassis, we recommend that you maintain a minimum space of 6 inches (15 cm) between a wall and the chassis and power supply unit air intakes or a wall and the chassis and power supply unit hot air exhausts. In situations where the switch chassis are installed in adjacent racks, you should allow a minimum space of 12 inches (30.5 cm) between the air intake of one chassis and the hot air exhaust of another chassis. Failure to maintain adequate spacing between chassis may cause the switch chassis that is drawing in the hot exhaust air to overheat and fail.

## Site Preparation Checklist

The following table lists the site-planning activities that you should perform prior to installing the switch. Completing each activity helps ensure a successful switch installation.

**Table 7: Site Preparation Checklist**

Task No.	Activity	Verified By	Time	Date
1	Space evaluation <ul style="list-style-type: none"> <li>• Space and layout</li> <li>• Floor covering</li> <li>• Impact and vibration</li> <li>• Lighting</li> <li>• Maintenance access</li> </ul>			
2	Environmental evaluation <ul style="list-style-type: none"> <li>• Ambient temperature</li> <li>• Humidity</li> <li>• Altitude</li> <li>• Atmospheric contamination</li> <li>• Airflow</li> </ul>			
3	Power evaluation <ul style="list-style-type: none"> <li>• Input power type</li> <li>• Power receptacles (Depends on power supply)<sup>1</sup></li> <li>• Receptacle proximity to the equipment.</li> <li>• Dedicated (separate) circuits for redundant power supplies.</li> <li>• UPS for power failures<sup>2</sup></li> </ul>			

Task No.	Activity	Verified By	Time	Date
4	Grounding evaluation <ul style="list-style-type: none"> <li>• Circuit breaker size</li> <li>• CO ground (AC powered systems)</li> </ul>			
5	Cable and interface equipment evaluation <ul style="list-style-type: none"> <li>• Cable type</li> <li>• Connector type</li> <li>• Cable distance limitations</li> <li>• Interface equipment (transceivers)</li> <li>• Cable bundling sizes</li> </ul>			
6	EMI evaluation <ul style="list-style-type: none"> <li>• Distance limitations for signaling</li> <li>• Site wiring</li> <li>• RFI levels</li> </ul>			

<sup>1</sup> Verify that each power supply installed in the chassis has a dedicated AC source circuit.

<sup>2</sup> Refer to the power supply VA rating as a sizing criterion in determining the output required by the UPS. The power supply kVA rating value is listed in the specifications table for each power supply in Appendix A (power supply specifications).







## CHAPTER 3

# Installing the Switch

---

- [Unpacking the Switch, on page 35](#)
- [Install the Switch as Shipped, on page 36](#)
- [Install the Switch with Shelf Brackets, on page 42](#)
- [Install the Switch in NEBS-Compliant Mode, on page 56](#)
- [Establishing System Ground, on page 64](#)
- [Attaching an ESD Strap, on page 66](#)
- [Verifying the Switch Chassis Installation, on page 67](#)

## Unpacking the Switch

Check the contents of the shipping container:

### Procedure

---

- Step 1** Check the contents of the accessory kit. Verify that you have received all the listed equipment, including any optional equipment you may have ordered, such as, network interface cables, transceivers, or special connectors.
- Step 2** Check the modules in each slot. Ensure that the configuration matches the packing list and that all of the specified interfaces are included.
- Step 3** Store the shipping carton.
- Tip** Do not discard the shipping container when you unpack the switch. Flatten the shipping cartons and store them with the pallet. You will require these containers if you have to move or ship the switch in the future.
-

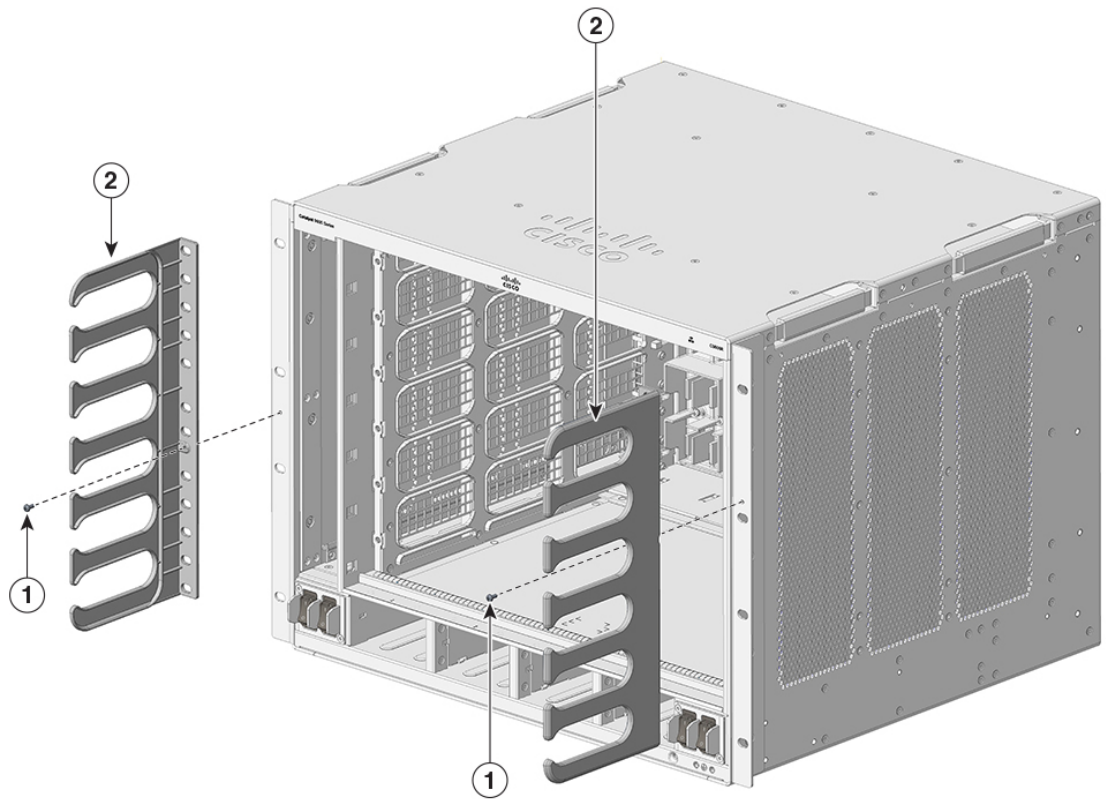
# Install the Switch as Shipped

## Installing the Cable Guide on the Chassis with L-Brackets Preinstalled on the Chassis

### Procedure

- Step 1** Position the cable guides to align with the L-brackets preinstalled on the chassis and secure the cable guides to the L-brackets using the screws provided.

*Figure 9: Attaching the Cable Guides*

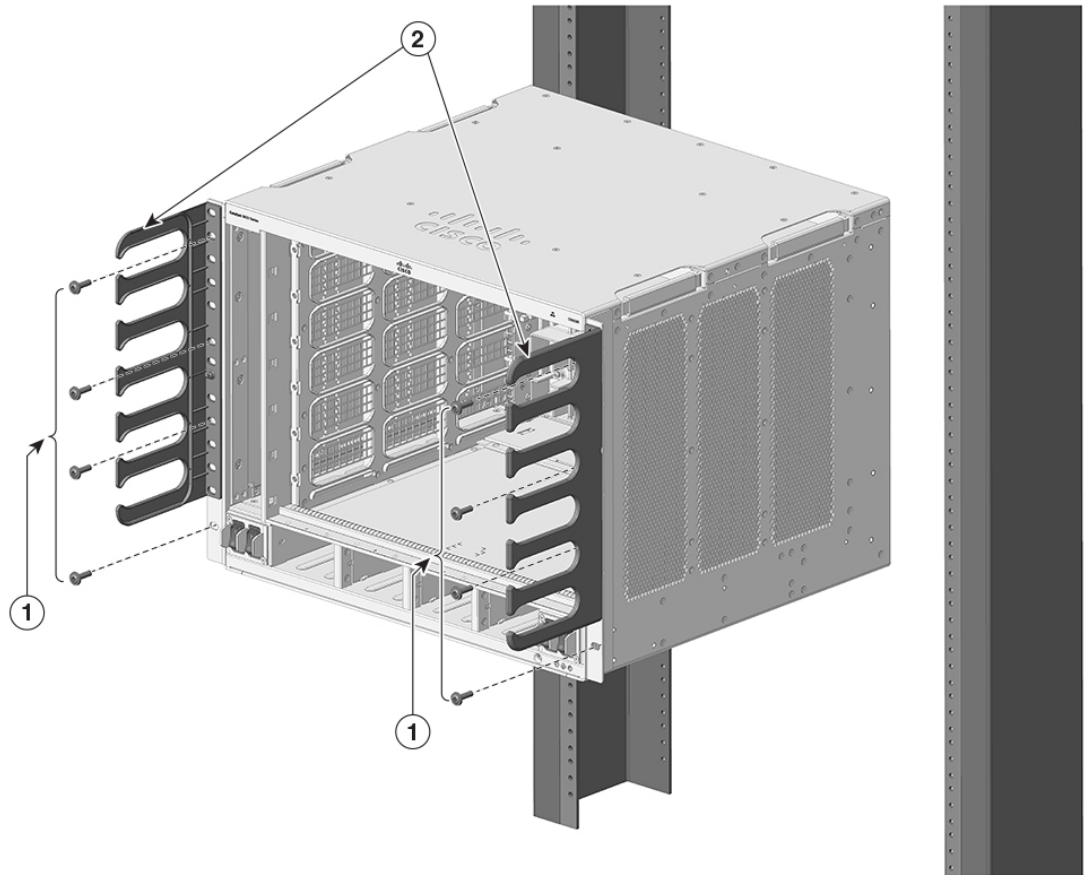


356054

1	Screws to attach the cable guides to the L-brackets on the chassis	2	Cable guides
---	--	---	--------------

- Step 2** Secure the chassis to the rack rails with four screws on each side.

Figure 10: Mounting the Chassis to the Rack

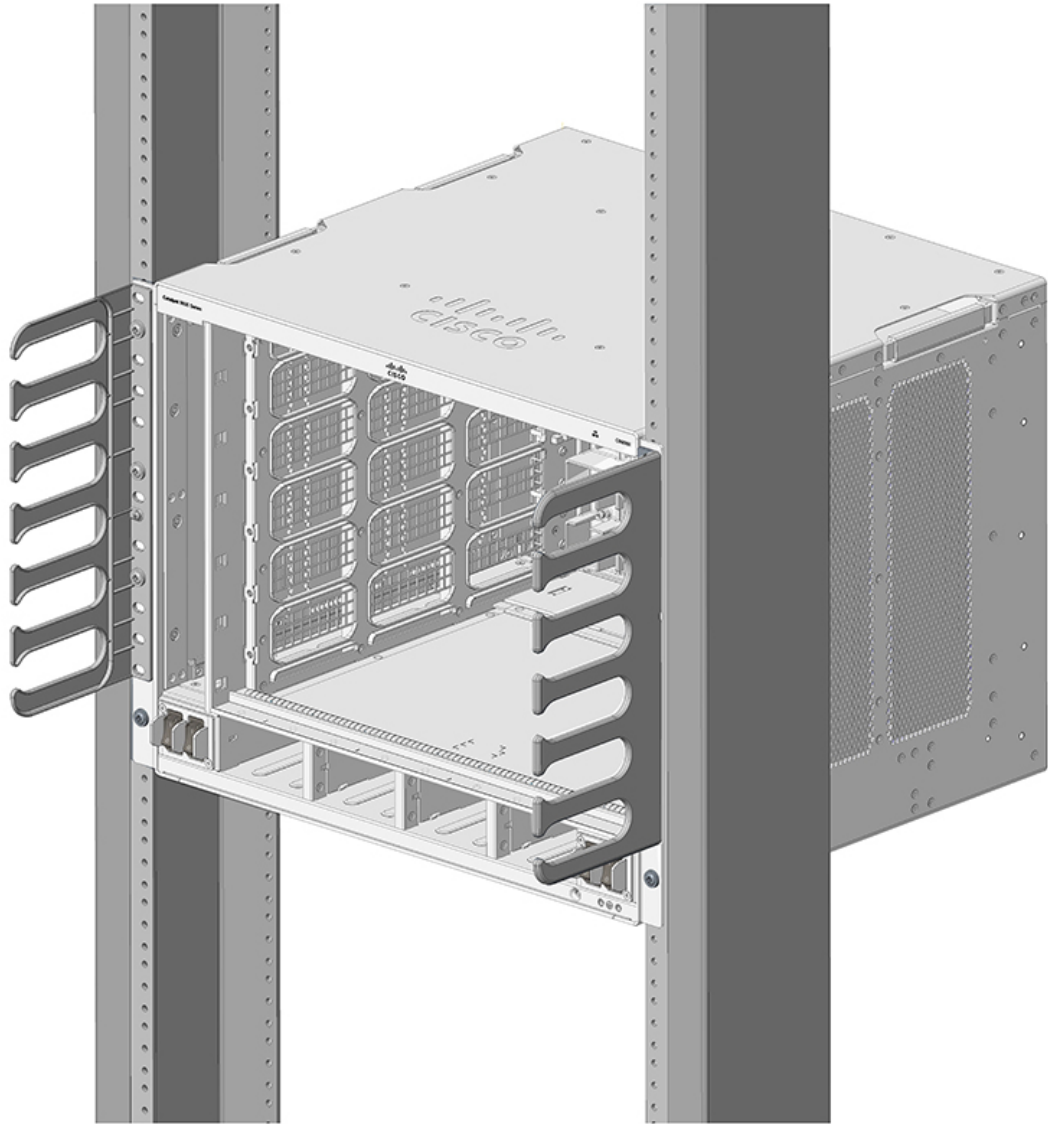


356048

1	Screws to attach the chassis to the rack post	2	Cable guide installed
---	---	---	-----------------------

Cable guide installation is complete.

Figure 11: Chassis with Cable Guide Attached



356049

## Rack-Mounting the Chassis as Shipped

This procedure shows how to rack mount the chassis as shipped.

## Before you begin



---

**Warning** To prevent bodily injury when mounting or servicing this unit in a rack, you must take special precautions to ensure that the system remains stable. The following guidelines are provided to ensure your safety:

- This unit should be mounted at the bottom of the rack if it is the only unit in the rack.
- When mounting this unit in a partially filled rack, load the rack from the bottom to the top with the heaviest component at the bottom of the rack.

If the rack is provided with stabilizing devices, install the stabilizers before mounting or servicing the unit in the rack.

## Statement 1006

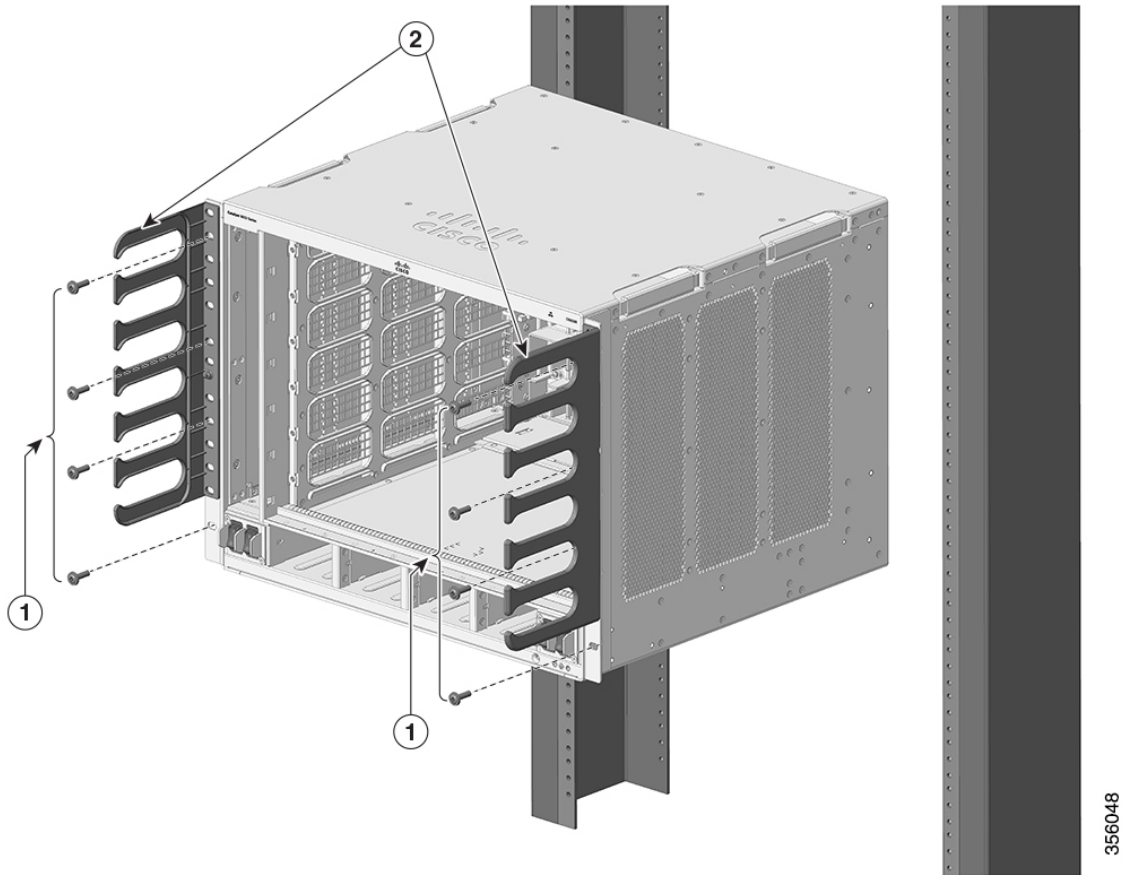
---

## Procedure

---

- Step 1** Insert the rear of the chassis between the mounting posts of the rack.
- Step 2** Align the mounting holes in the L bracket on the switch or on the cable mount (if installed) with the mounting holes in the equipment rack.

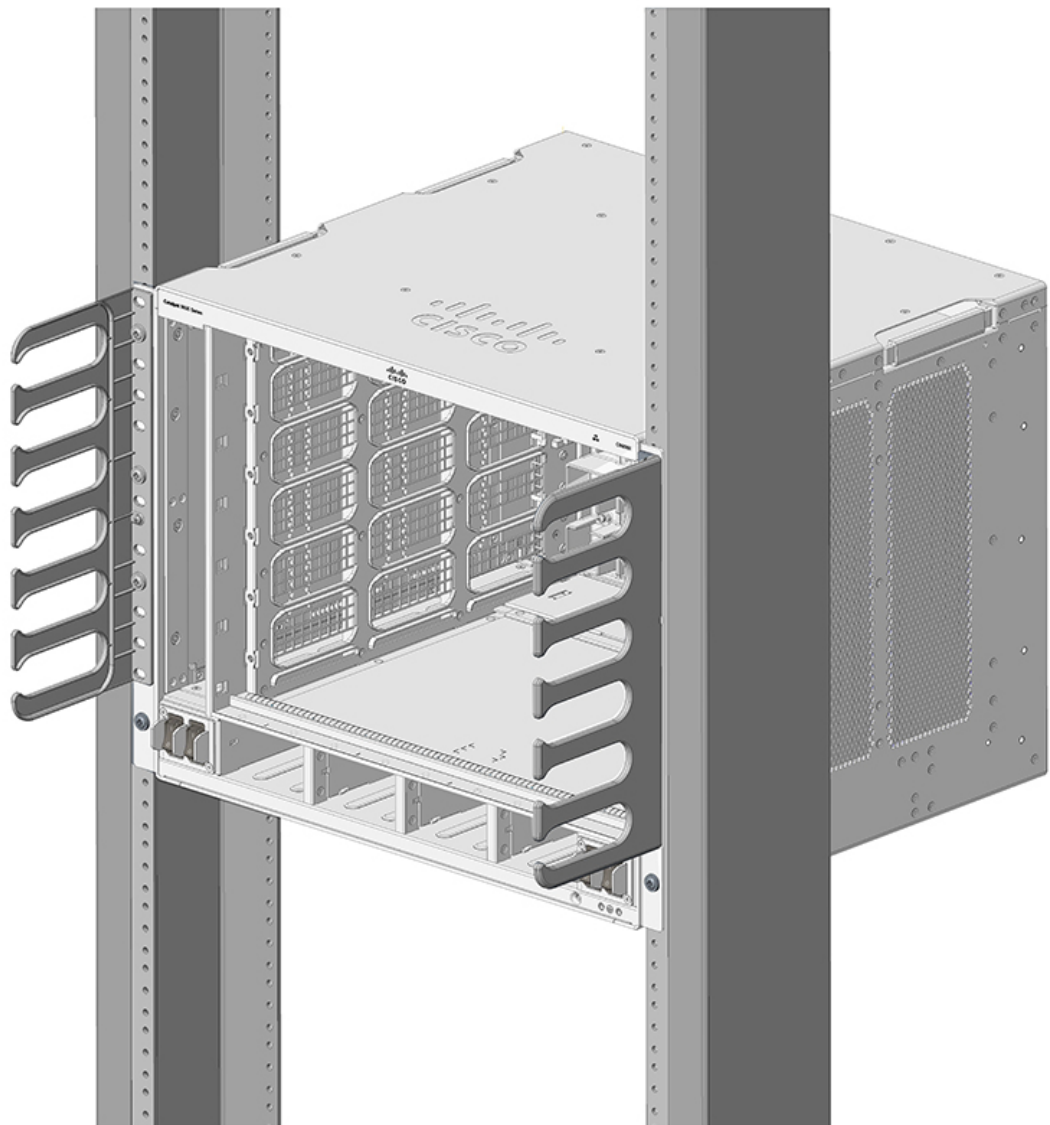
Figure 12: Securing the Chassis to the Rack Posts



1	10-32 or 12-24 pan head screws	2	Cable guides
---	--------------------------------	---	--------------

**Step 3** Secure the chassis to the rack with either 10-32 or 12-24 pan head screws from the chassis standard accessory kit.

Figure 13: Chassis Secured to the Rack Posts



356049

- Step 4** 4. Use a tape measure and level to ensure that the chassis is installed straight and level..

---

#### What to do next

After installing the chassis in its location, complete the installation process by:

1. Connecting the chassis to system ground.
2. Installing and connecting the power supplies to the power source.
3. Connecting the network interface cables to the supervisor module and line card modules. This may involve installing transceivers before you attach the network interface cables.

4. Powering up the chassis and verifying the installation.

## Install the Switch with Shelf Brackets

### Installing the Shelf Kit L-Brackets

The switch chassis is shipped with two L-brackets installed on the front sides of the chassis. If you are rack-mounting the switch using the shelf kit, these L-brackets must be removed and replaced with L-brackets that are part of the shelf kit.

#### Before you begin

You have ordered and received the shelf kit.

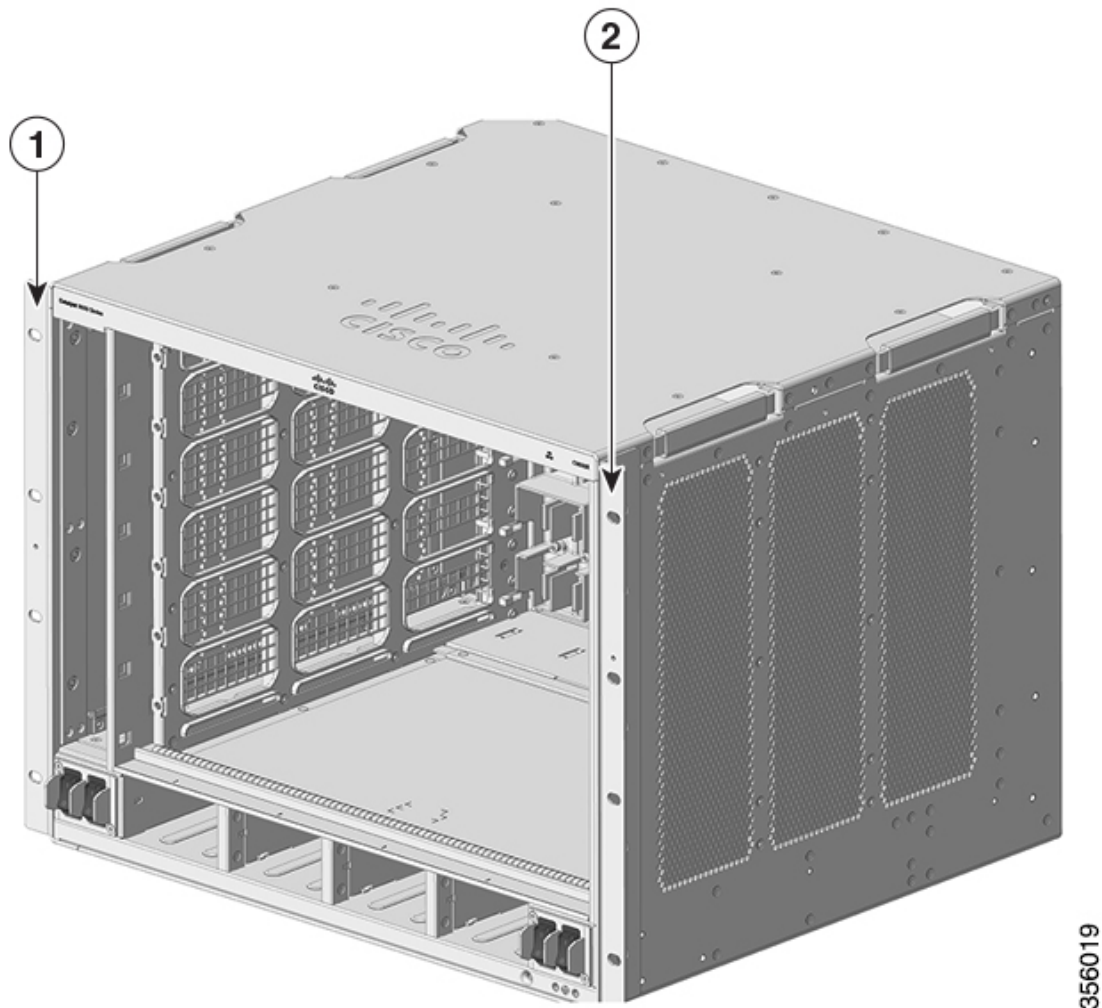
#### Procedure

---

- Step 1** Remove and discard the L-brackets and the ten mounting screws that the chassis is shipped with. Do not re-use them during any part of the installation process.

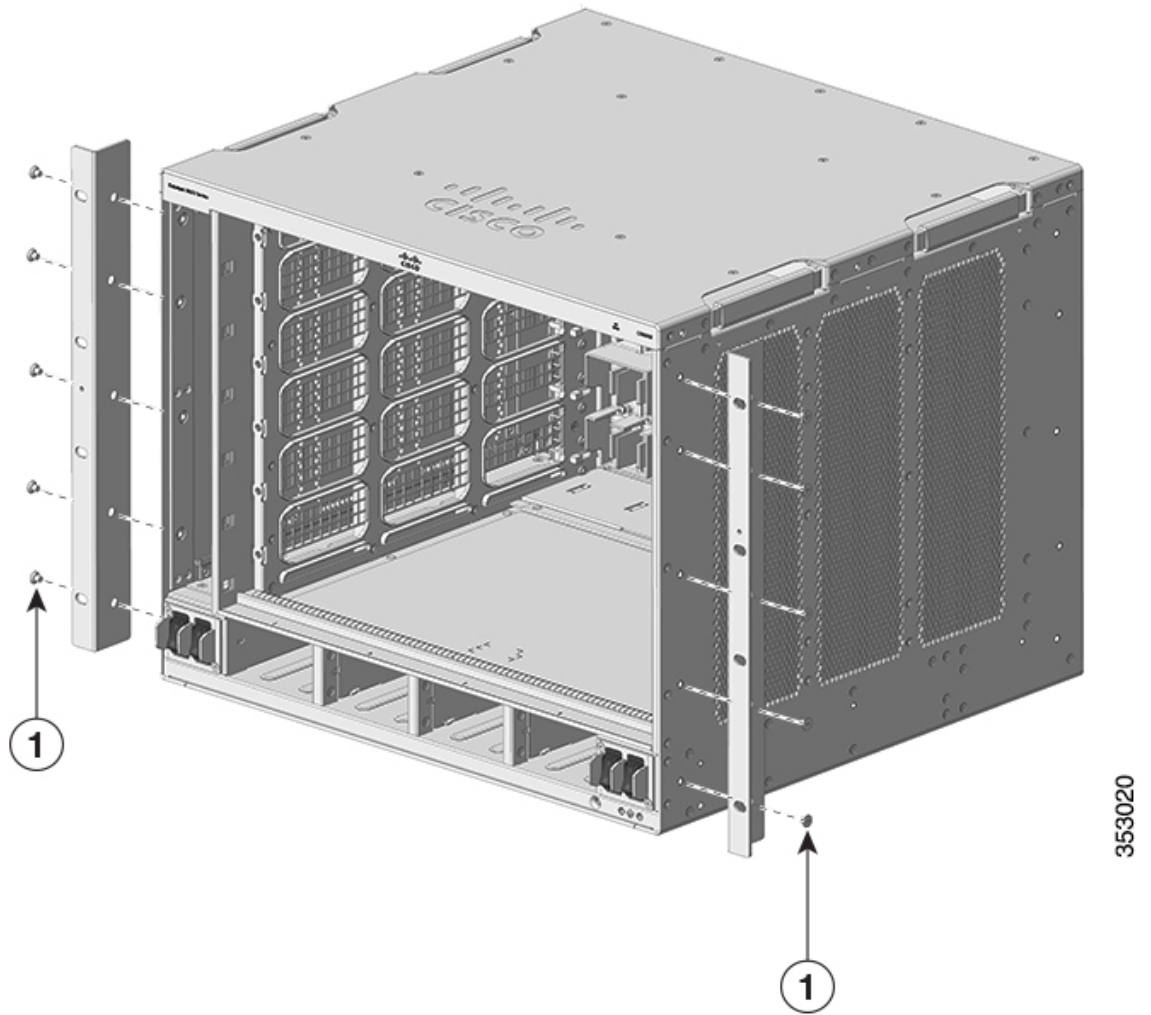


Figure 14: L-Brackets the Chassis is Shipped with



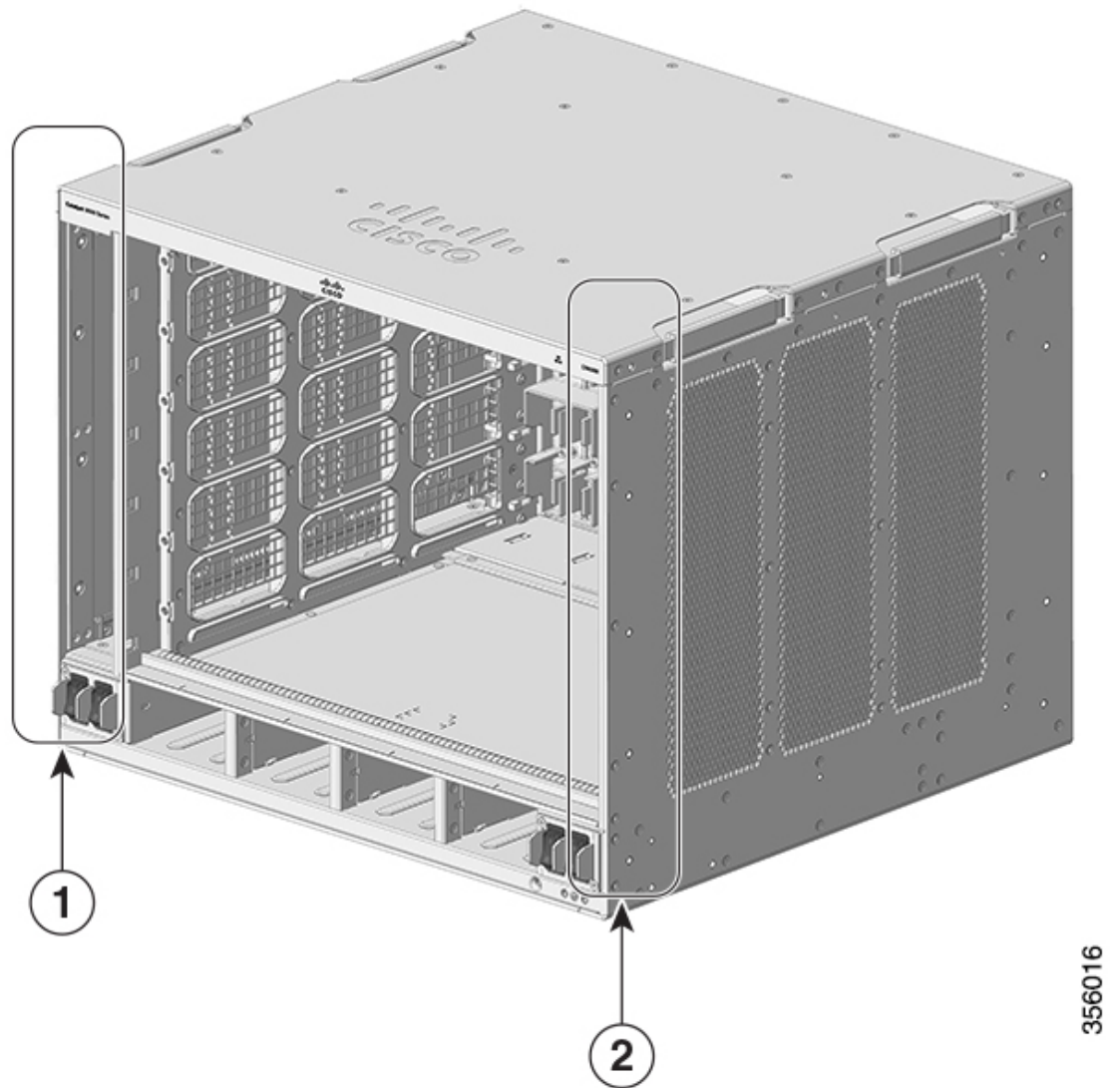
1	Left L-bracket	2	Right L-bracket
---	----------------	---	-----------------

Figure 15: Removing L-Brackets the Chassis is Shipped With



1	Mounting screws the chassis is shipped with	-	-
---	---	---	---

Figure 16: Chassis Without L-Brackets

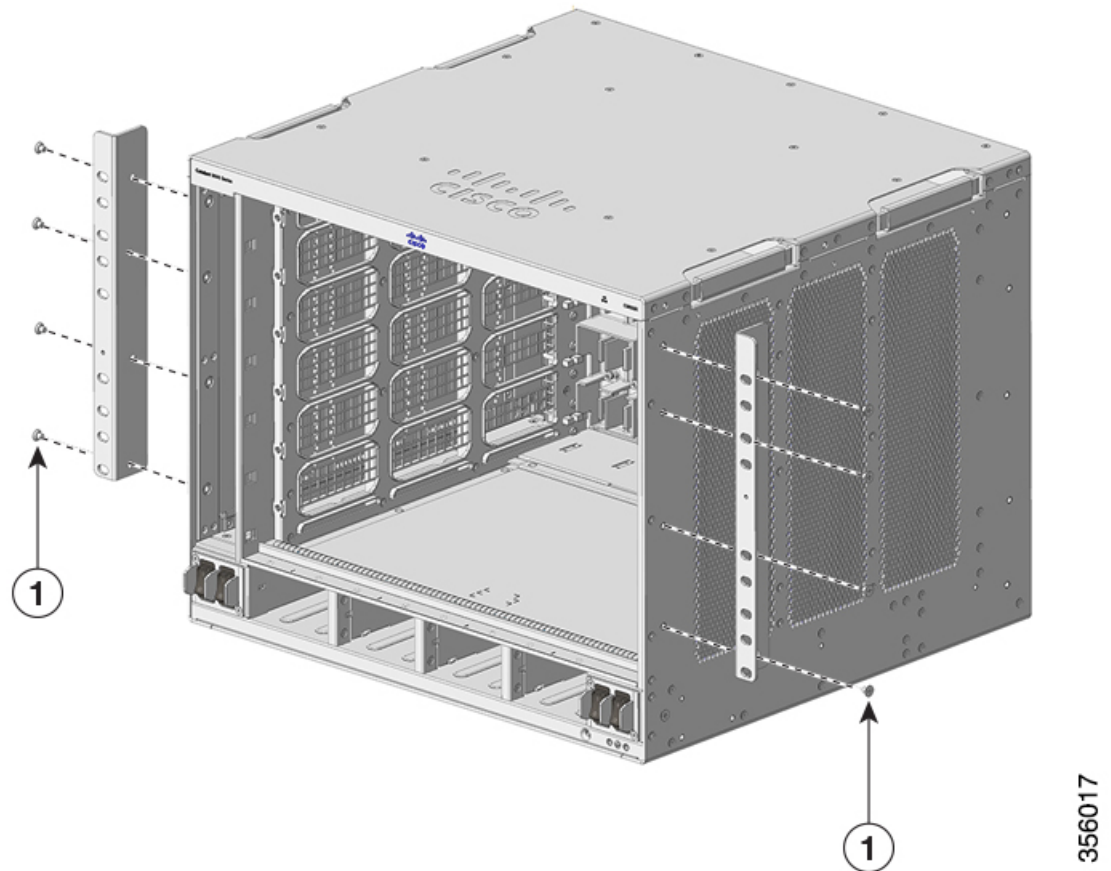


1	Chassis without left L-bracket	2	Chassis without right L-bracket
---	--------------------------------	---	---------------------------------

**Step 2**      Unpack the L-brackets from the shelf kit.

**Step 3**      Using the M4 x 8 mm Phillips flat head screws in the shelf kit, secure the L-brackets to the front-left and front-right sides of the chassis (four on each side).

Figure 17: Installing Shelf Kit L-Brackets



1	M4 x 8 mm Phillips flat head screws	-	-
---	-------------------------------------	---	---

**What to do next**

Install the shelf brackets on the rack.

## Installing the Shelf Brackets and the Crossbar

Install the shelf brackets and the crossbar before you install the chassis in the rack to help support the weight of the chassis while you secure the L-brackets to the rack enclosure.

You have to front-mount the shelf brackets.

**Before you begin**

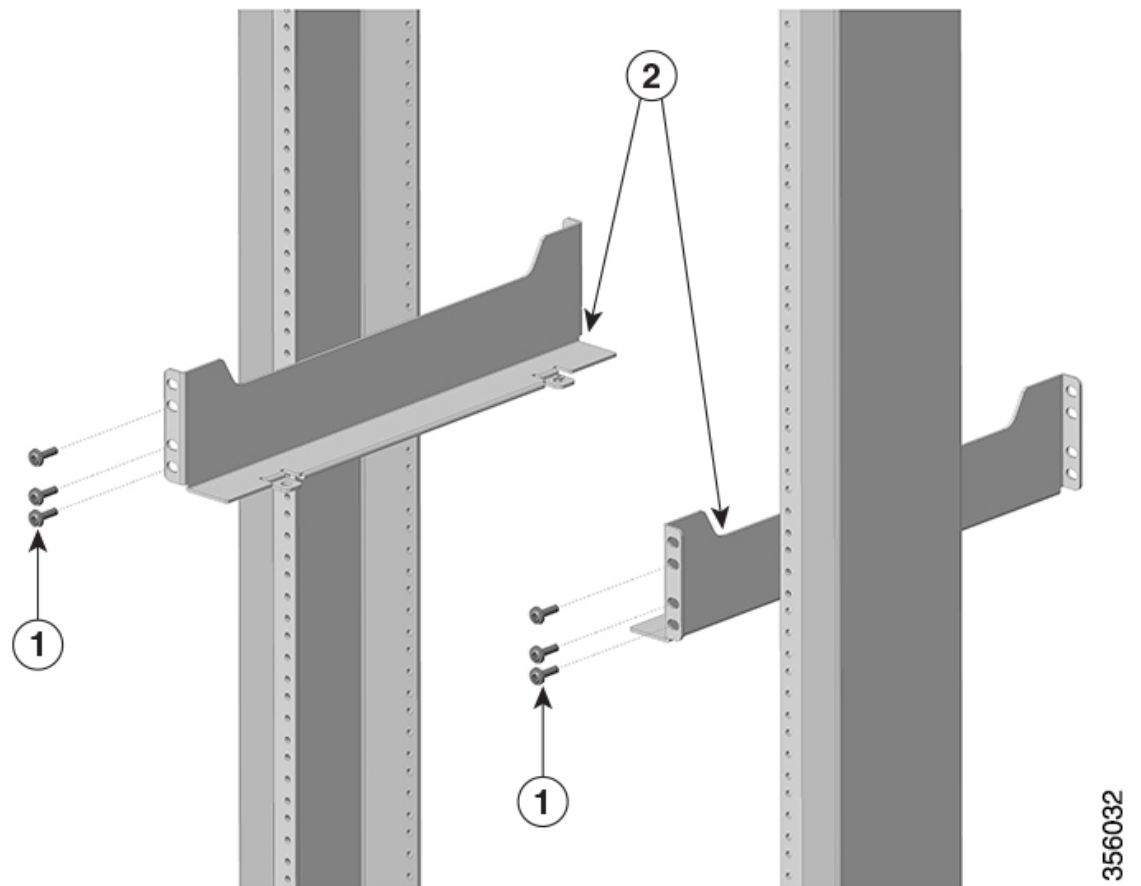
Determine the clearance between the insides of the left and right rails of your rack system and install the shelf brackets accordingly. Keep these tools handy:

- Number 1 and Number 2 Phillips screwdrivers
- 3/16-inch flat-blade screwdriver
- Tape measure and level

### Procedure

- Step 1** Position the support flange of the left shelf bracket on the front of the left rail. Align and secure the bracket to the rack by using three screws. Use either 10-32 or 12-24 pan head screws from the shelf kit.
- Step 2** Position the support flange of the right shelf bracket on the front of the right rail — make sure that it is level with the left shelf bracket. Align and secure the bracket to the rack by using three screws.
- Use the same type of screws for the left and right shelf bracket.

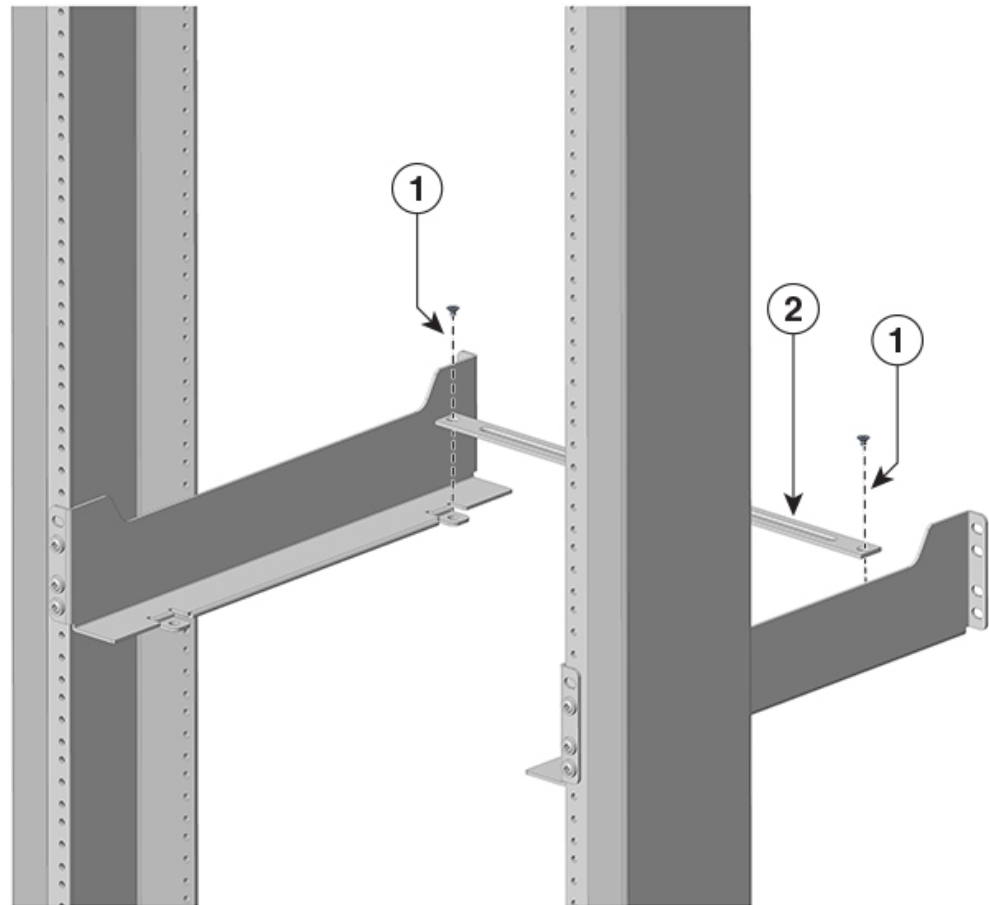
**Figure 18: Installing the Shelf Brackets**



1	Pan head screws from the shelf kit to secure the shelf brackets to the rack posts	2	Shelf brackets
---	---	---	----------------

**Step 3** Secure the crossbar to the shelf brackets by using two M4 screws, with one screw on each side.

*Figure 19: Securing the crossbar to the shelf brackets*



356032

1	M4 x 5 mm flat-head screw	2	Crossbar
---	---------------------------	---	----------

The shelf brackets and the crossbar are now securely mounted to the rack posts.

#### What to do next

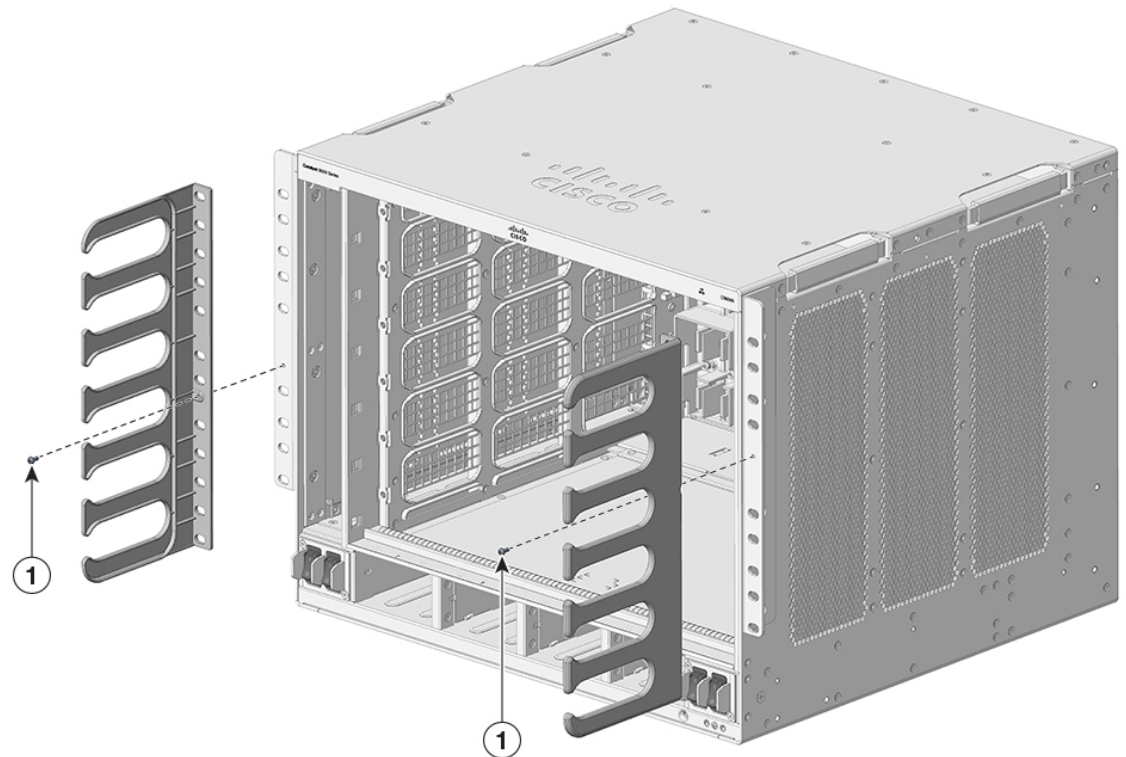
Install the cable guide to the chassis. Two people will be required for this task.

## Installing the Cable Guide on the Chassis with Shelf Kit L-Bracket

### Procedure

**Step 1** Position the cable guides and align with the shelf kit L-brackets installed on the chassis.

Figure 20: Installing the Cable Guide



356037

1	Screws to mount the cable guide
---	---------------------------------

**Step 2** Secure the cable guides to the L brackets using the screws (one on each side) provided.

#### What to do next

Rack mount the chassis to a rack installed with shelf brackets and a crossbar.

## Rack-Mounting the Chassis

This procedure shows how to rack mount the chassis with shelf brackets.



**Warning** Two people are required to lift the chassis. To prevent injury, keep your back straight and lift with your legs, not your back. **Statement 164**



**Tip** We recommend that you have a third person to assist in this procedure.

**Warning**

To prevent bodily injury when mounting or servicing this unit in a rack, you must take special precautions to ensure that the system remains stable. The following guidelines are provided to ensure your safety:

- This unit should be mounted at the bottom of the rack if it is the only unit in the rack.
- When mounting this unit in a partially filled rack, load the rack from the bottom to the top with the heaviest component at the bottom of the rack.

If the rack is provided with stabilizing devices, install the stabilizers before mounting or servicing the unit in the rack.

**Statement 1006**

To install the switch chassis in the equipment rack, perform these steps:

**Before you begin**

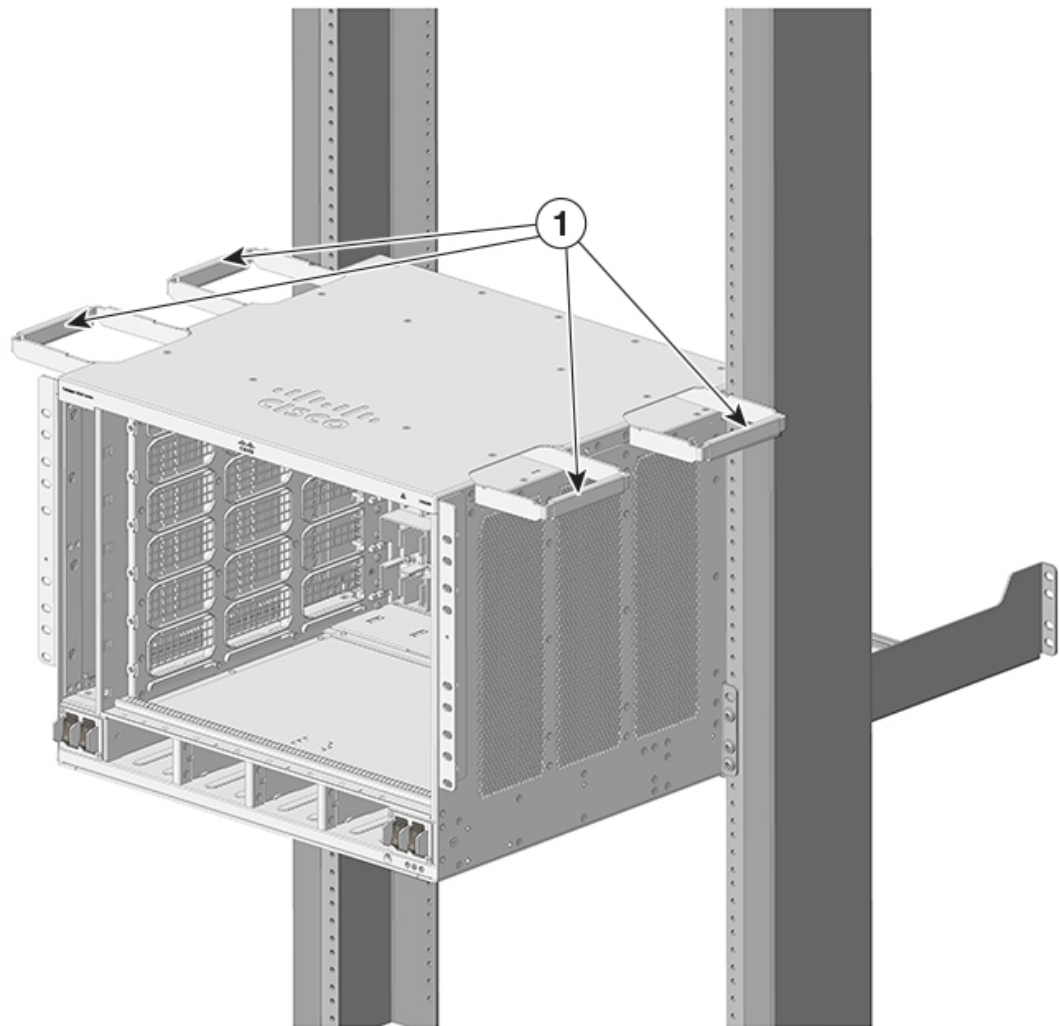
- Install the shelf kit L brackets on the chassis and the shelf brackets and crossbar on the rack posts.
- Install the cable guide.

**Procedure**

- 
- Step 1** Pull out all four of the handholds on the chassis.



Figure 21: Chassis handholds

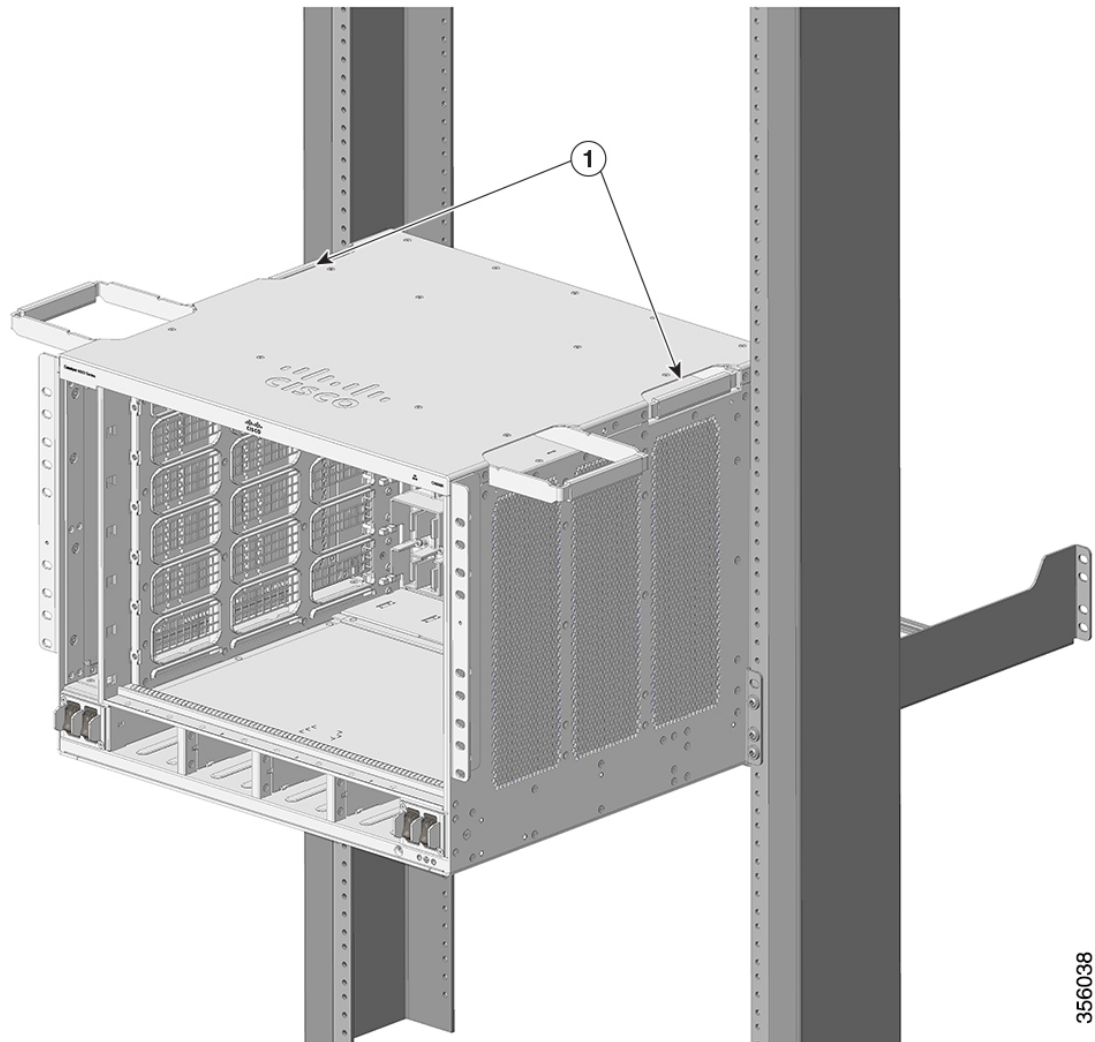


355034

1	All four of the chassis handholds pulled out and the back end of the chassis resting on the edges of the shelf bracket rails.	-	-
---	---	---	---

- Step 2** With a person standing at each side of the chassis, insert one hand into each handhold. Slowly lift the chassis. Avoid sudden twists or moves to prevent injury.
- Step 3** Rest the back end of the chassis on the edges of the shelf bracket rails and slide it in until the first pair of handles on both sides of the chassis are near the rack posts.
- Step 4** Push in the handholds that are closest to the rack posts.

Figure 22: Sliding the Chassis in - Part 1

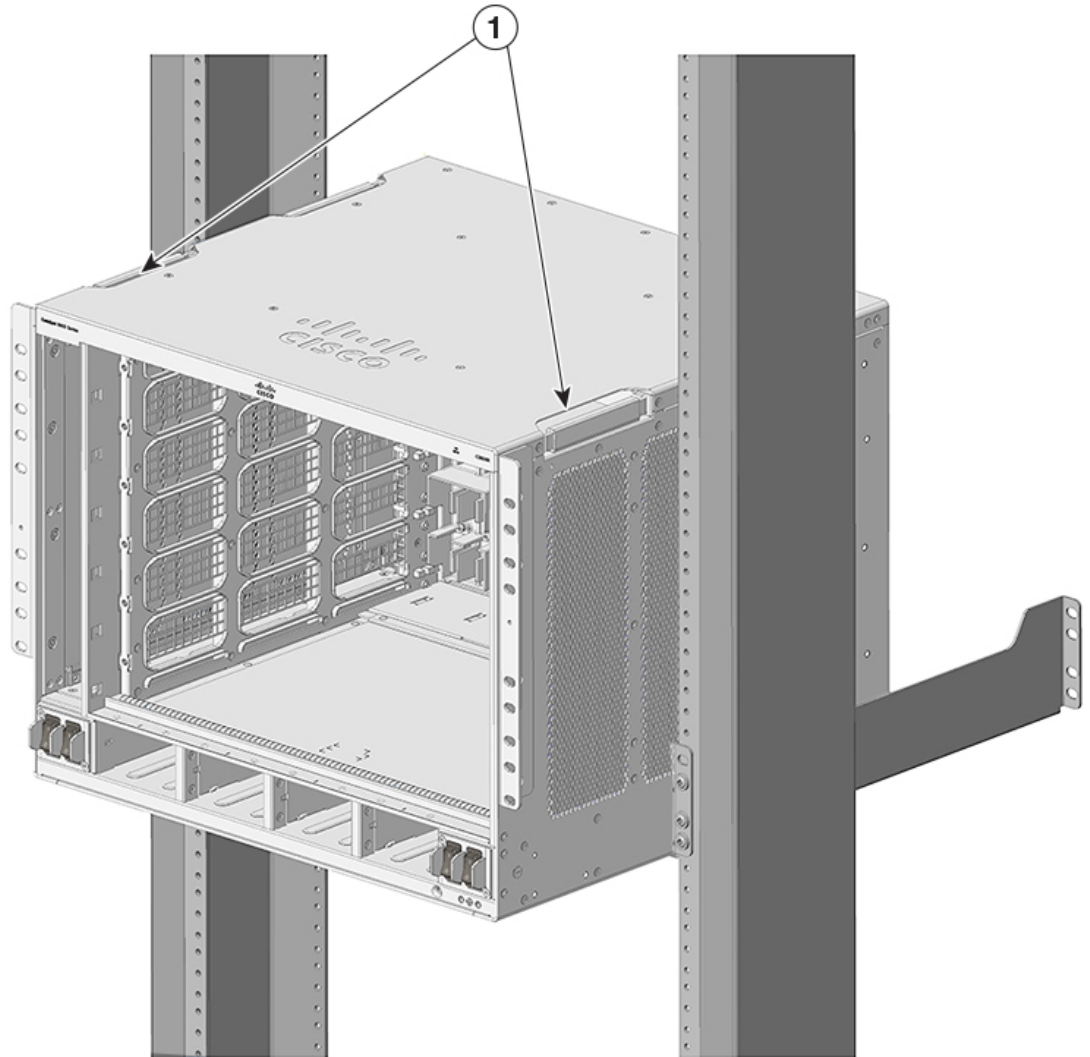


356038

1	Handholds closest to the rack posts, pushed in.	-	-
---	---	---	---

**Step 5** Continue sliding the chassis in until the second pair of handholds are near the rack posts. Push in the second pair of handholds.

Figure 23: Sliding the Chassis in - Part 2



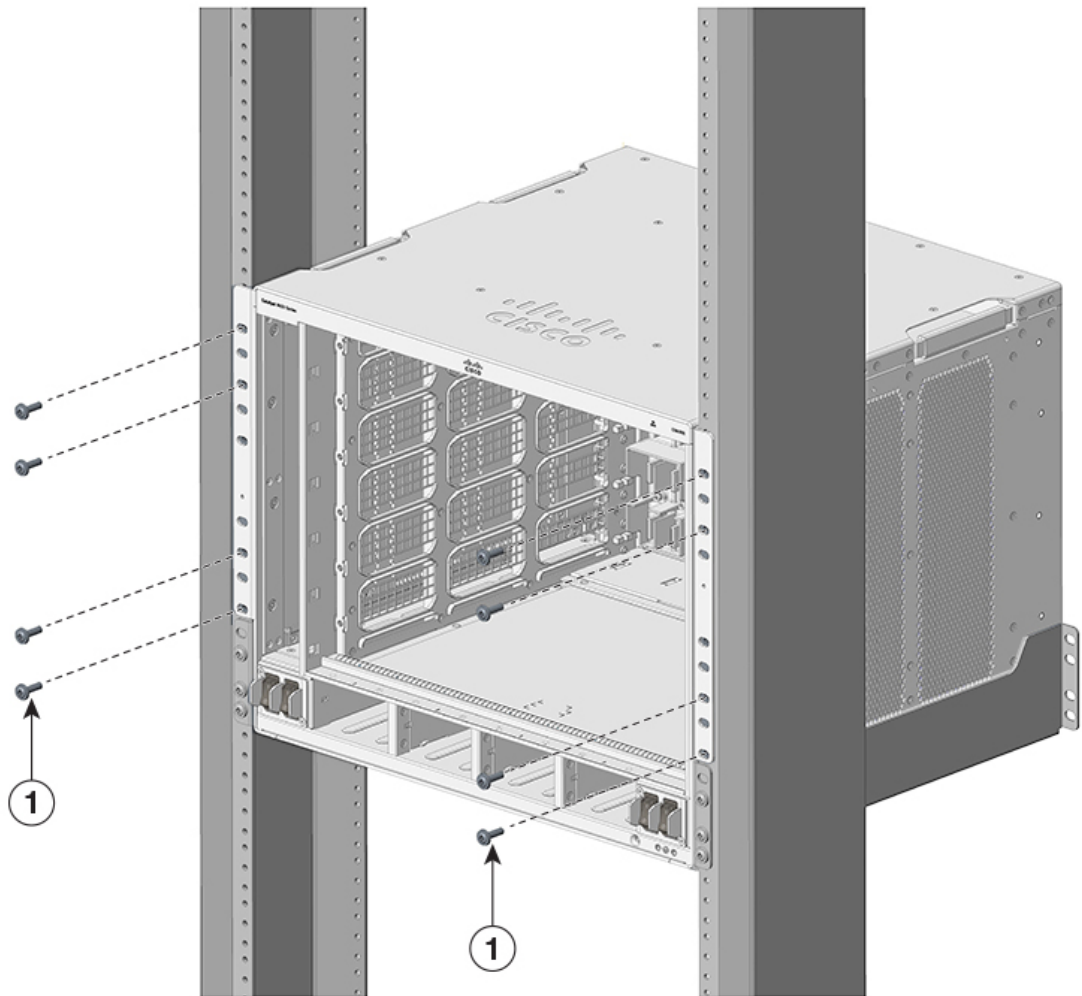
356040

1	Second pair of handholds, pushed in.
---	--------------------------------------

**Step 6** Continue sliding the chassis rests completely on the shelf brackets and the crossbar. Slide in further until the L brackets make contact with the rack posts.

**Step 7** Secure the chassis to the rack with either the 10-32 or 12-24 pan head screws from the chassis standard accessory kit.

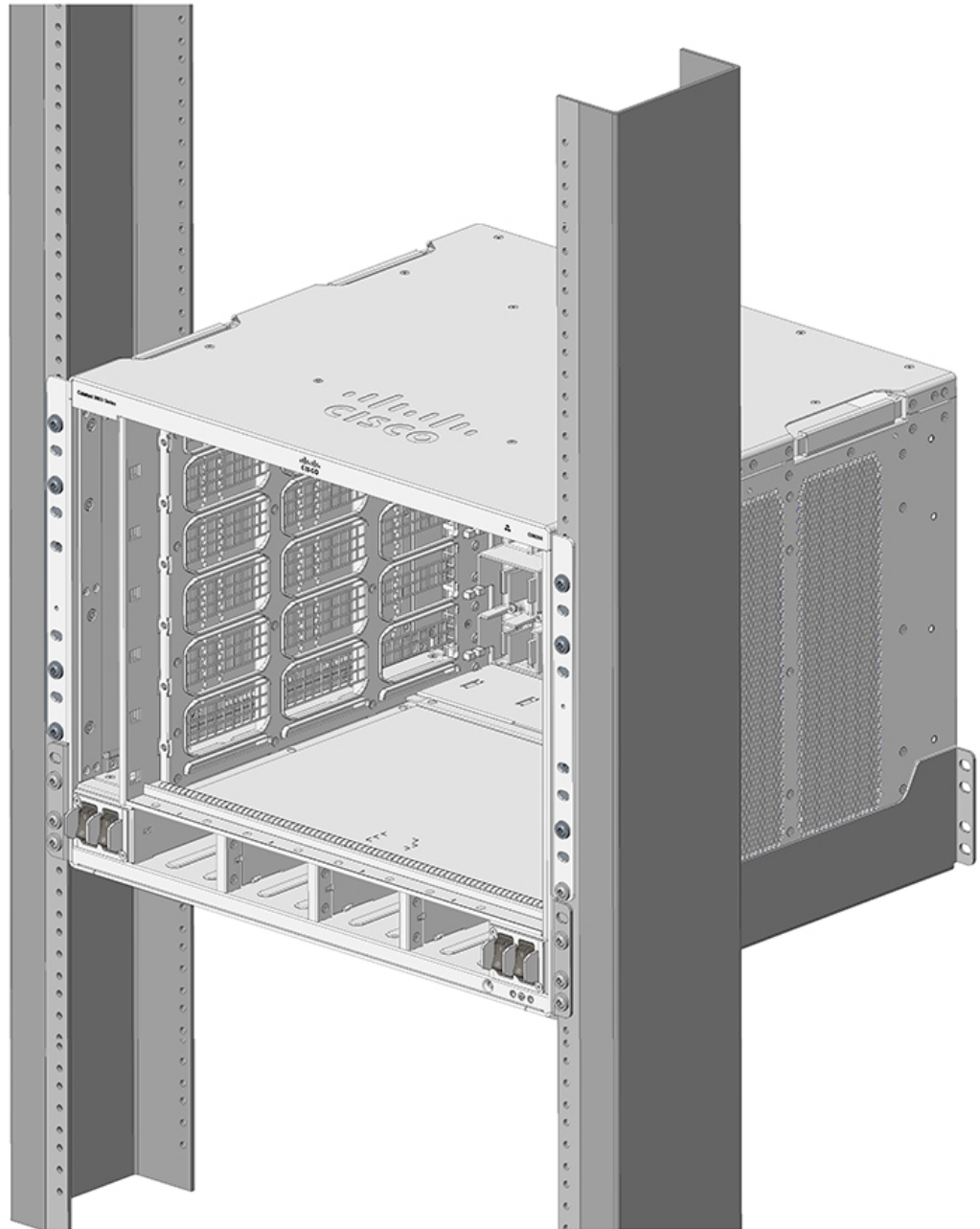
Figure 24: Securing the Chassis to the Rack Posts



356045

1	10-32 or 12-24pan head screws
---	-------------------------------

*Figure 25: Chassis Secured to the Rack Posts*



356047

### **What to do next**

After installing the chassis in its location, complete the installation process by:

1. Connecting the chassis to system ground.
2. Installing and connecting the power supplies to the power source.

3. Connecting the network interface cables to the supervisor module and line card modules. This may involve installing transceivers before you attach the network interface cables.
4. Powering up the chassis and verifying the installation.

## Install the Switch in NEBS-Compliant Mode

### NEBS-Compliant Air Filter

A Network Equipment-Building System (NEBS) compliant installation allows filtered, front-to-rear airflow. To mount the chassis in a NEBS-compliant mode with the air filter, use a 23-inch rack mount. Filter brackets that are mounted on the side of the chassis hold the air filter.

A 23-inch rack mount is used for mounting the switch in a standard 23 inch (58.4 cm) equipment rack with two unobstructed outer posts. This kit is not suitable for racks with obstructions (such as a power strip) that could impair access to the field-replaceable units (FRUs) of the switch.

### Rack-Mounting the Chassis in NEBS-Compliant Mode

#### Before you begin

- Read [Safety Warnings](#) carefully before starting with any installation procedure to make sure you understand the hazards and precautions.
- Place the chassis on the floor or on a sturdy table as close as possible to the rack. Leave enough clearance to allow you to move around the chassis.
- Open the rack-mount kit (C9606-FB-23-KIT=) and verify that all parts are included.



---

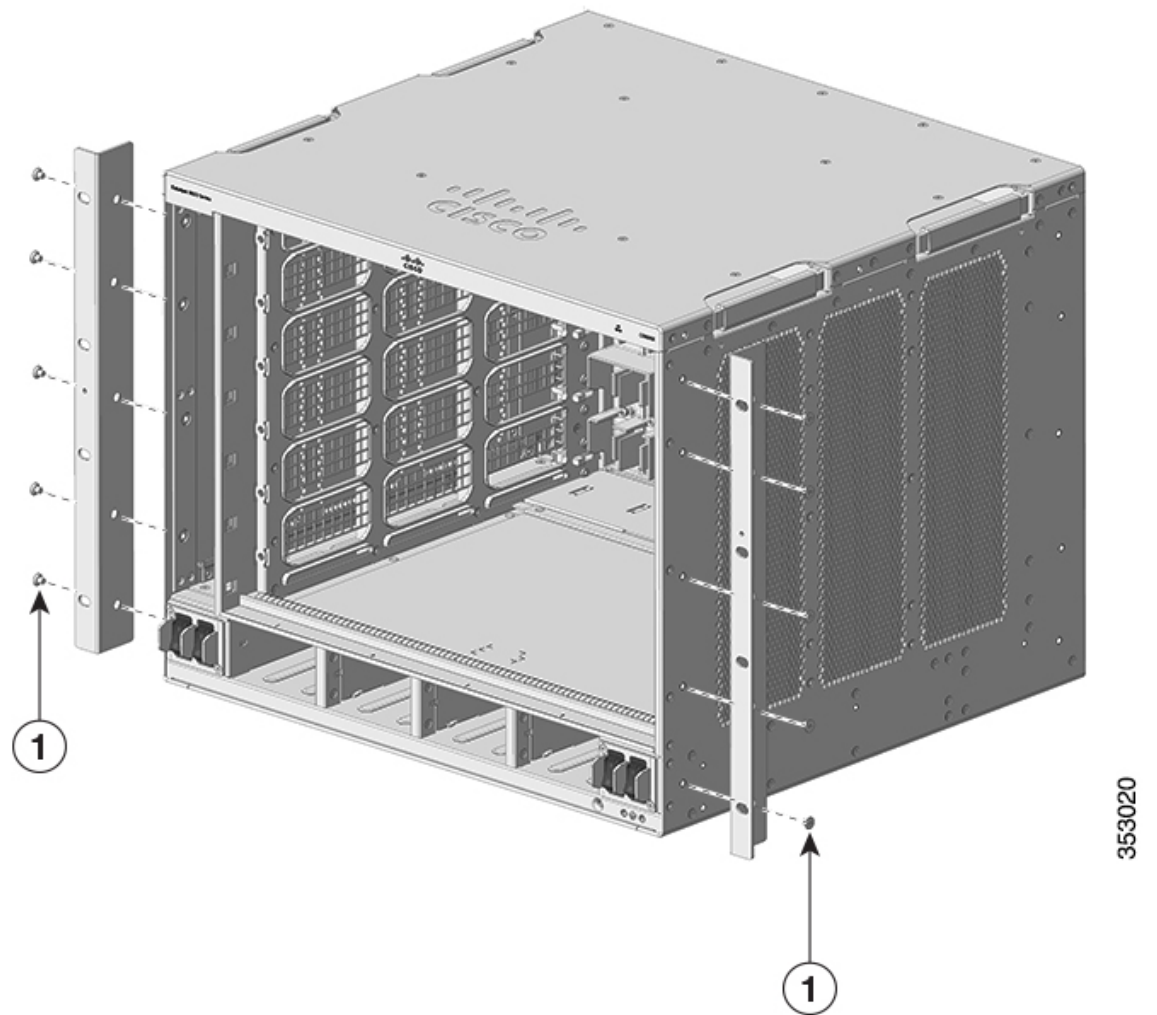
**Note** Some equipment racks provide a power strip along the length of one of the rear posts. If your rack has this feature, consider the position of the strip when planning fastener points. Before installing the brackets on the chassis, determine whether to install the chassis from the front or the rear of the rack.

---

#### Procedure

- 
- Step 1** Remove and discard the mounting ears and the ten mounting screws of the chassis. Do not reuse them during any part of the installation process.

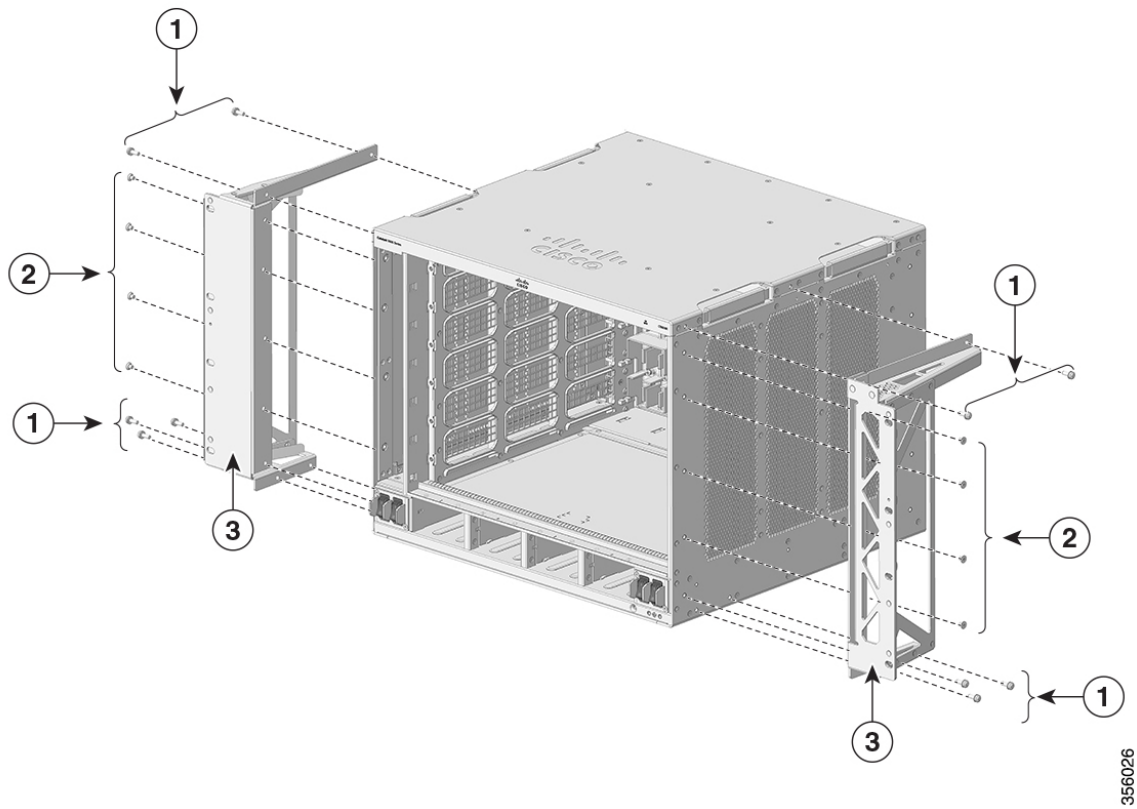
Figure 26: Remove the Mounting Ears



1	Mounting screws
---	-----------------

**Step 2** Install the rack ear brackets on the left and right sides of the chassis. These brackets connect the chassis to the rack.

Figure 27: Install the Rack Ear Brackets



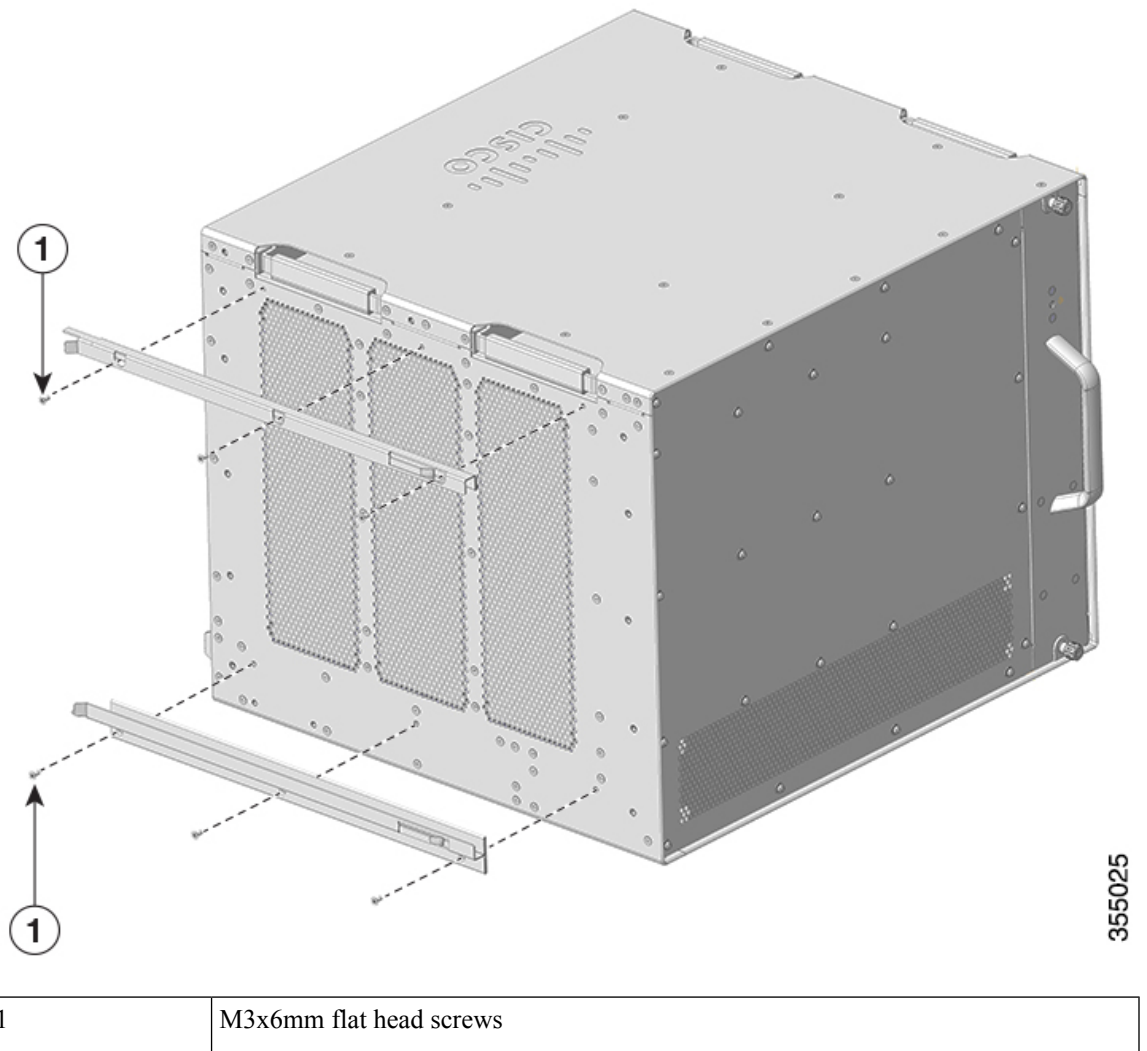
356026

1	10xM4 pan head screws 12 mm long	3	Rack ear brackets
2	8xM4 countersunk screws 5 mm long	-	-

**Step 3** Install the filter brackets.

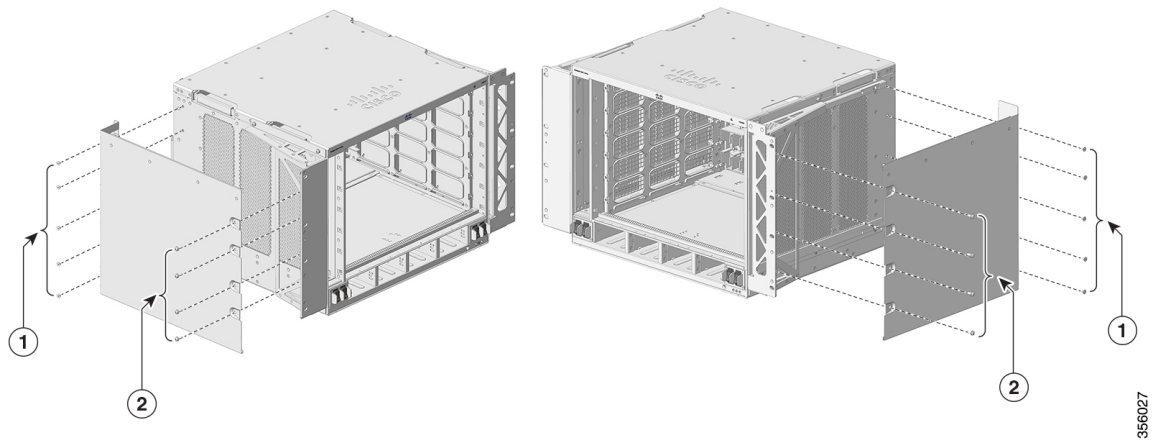


Figure 28: Install the Filter Brackets



**Step 4** Install the right and the left wall covers.

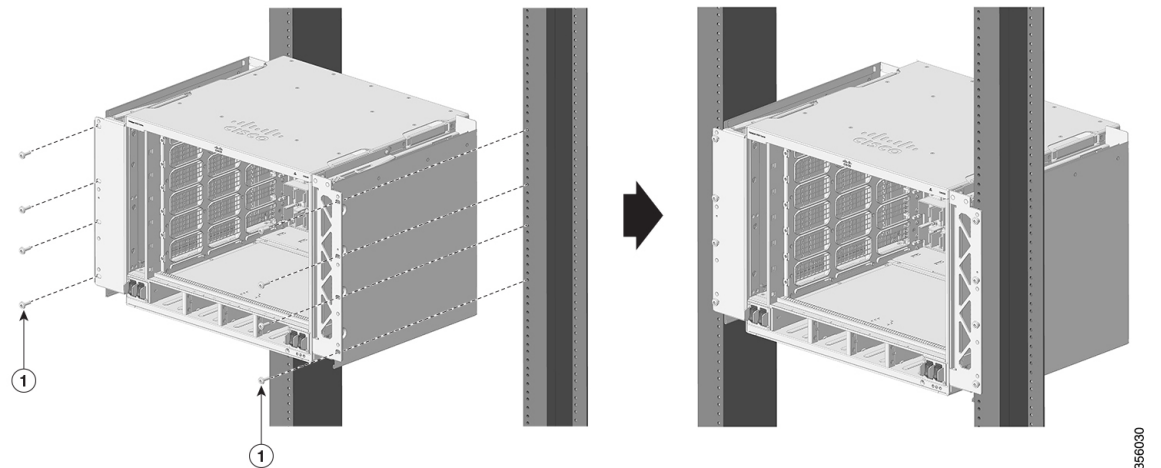
Figure 29: Install the Wall Covers



1	M4x5mm flat head screws	2	M4x12mm pan head screws
---	-------------------------	---	-------------------------

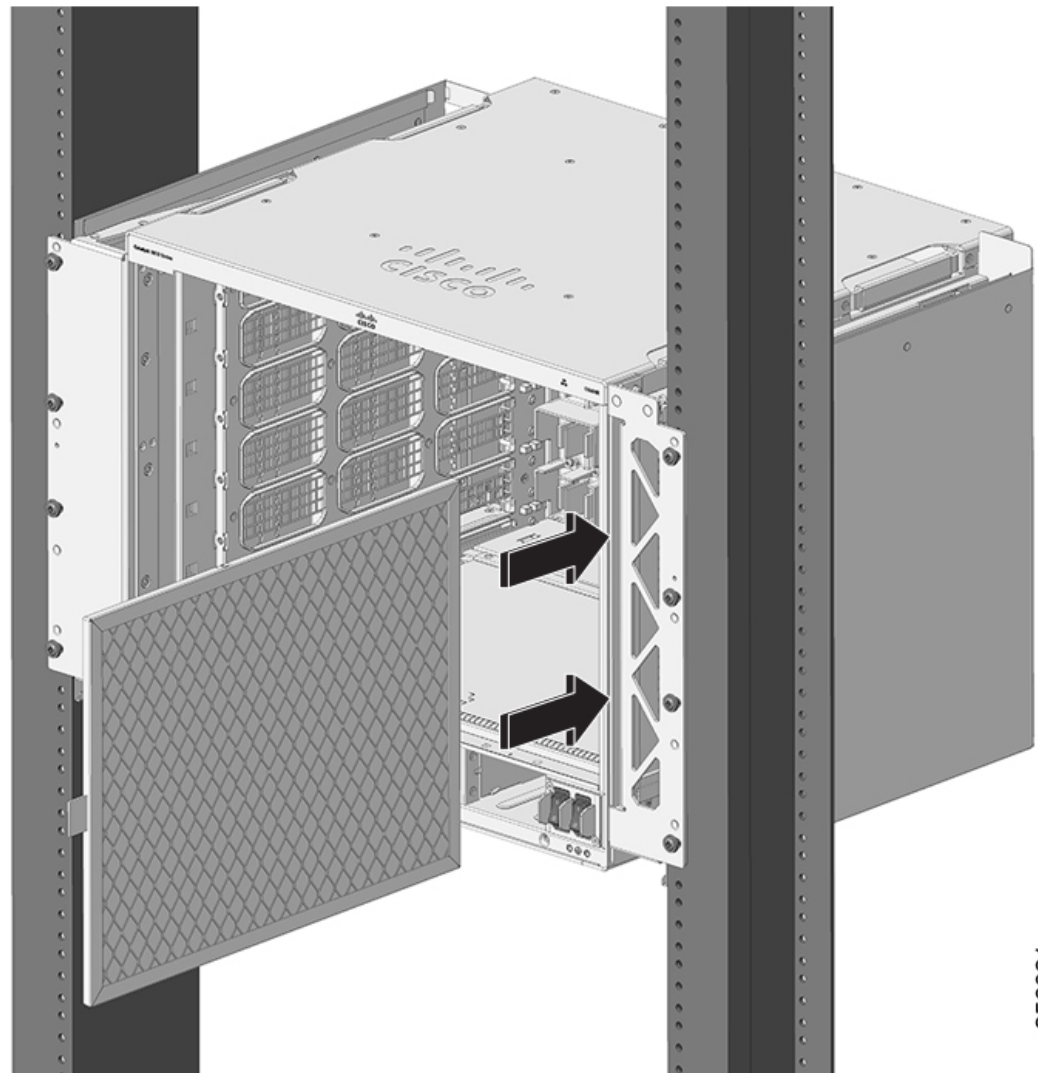
**Step 5** Secure the chassis to the rack with either 10-32 or 12-24 pan head screws from the chassis standard accessory kit.

Figure 30: Secure the Chassis to Rack



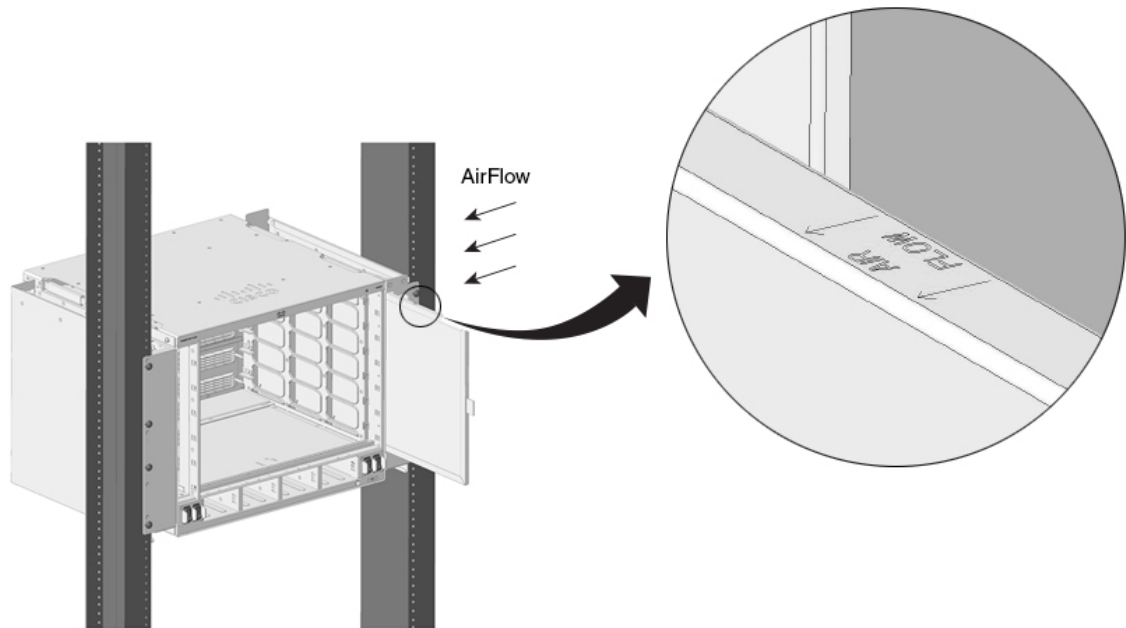
1	10-32 or 12-24 pan head screws
---	--------------------------------

**Step 6** Align the air filter with the top and the bottom edges of the air filter slot.



- Step 7** Insert the air filter into its housing with the arrows pointing toward the chassis. The arrows on the top edge of the air filter note the direction of airflow. Airflow direction is from right to left, when you stand facing the chassis.

Figure 31: NEBS-Compliant Air Filter

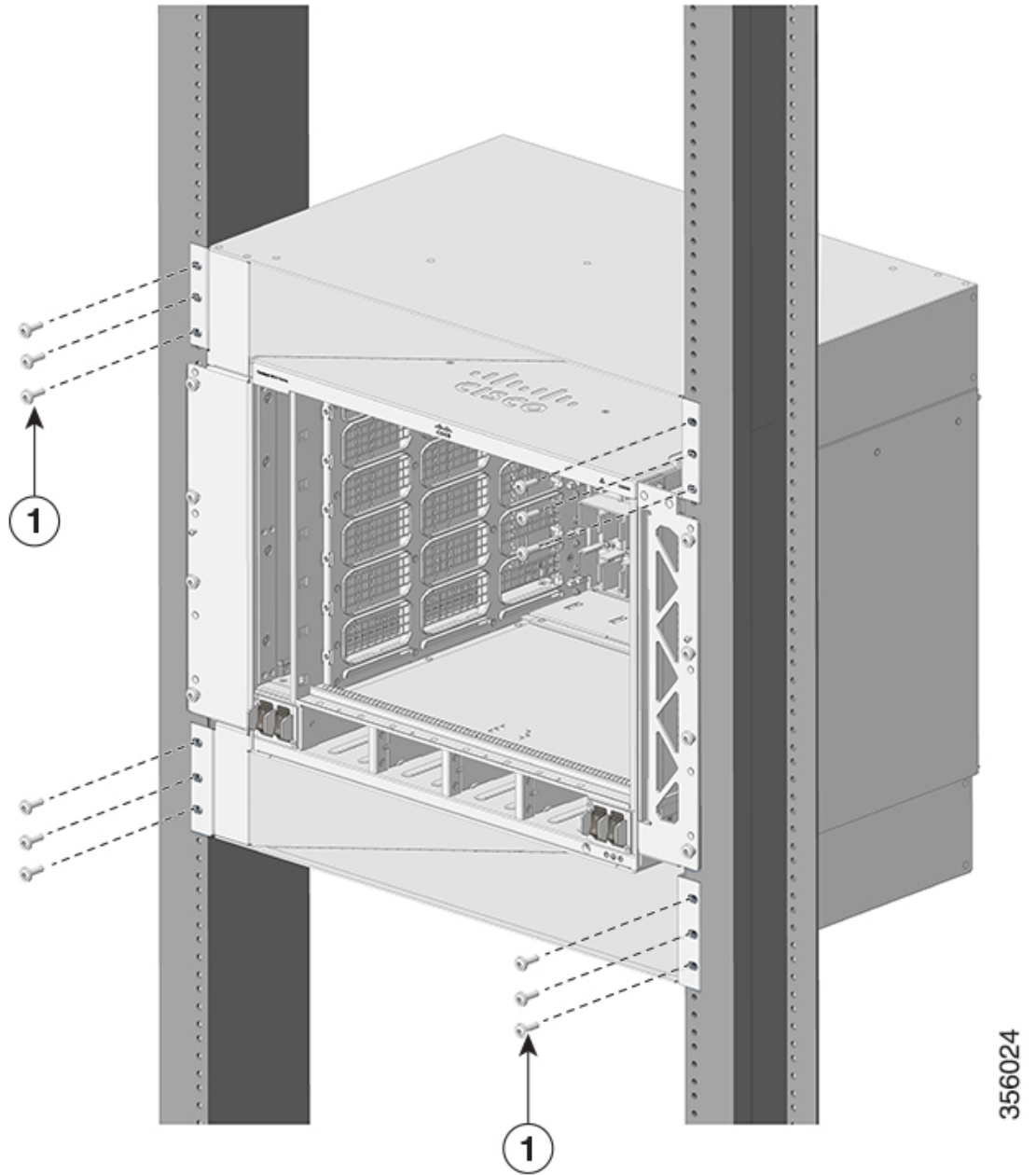


356028

**Note** We recommend that you change the air filter every 3 months. However, examine the air filter once a month (or more often in dusty environments) and replace it if it appears to be excessively dirty or damaged. To comply with Telecordia GR-63-Core standard air filter requirements for NEBS deployments, the air filter must be replaced, not cleaned.

**Step 8** Install the top and base covers as shown in the illustrations:

Figure 32: Top Cover and Base Cover



1	10-32 or 12-24 pan head screws
---	--------------------------------

356024

# Establishing System Ground

To attach the grounding lug and cable to the grounding pad, perform these steps:

## Before you begin



---

**Warning** Use copper conductors only. **Statement 1025**

---



---

**Warning** When stranded wiring is required, use approved wiring terminations, such as closed-loop or spade-type with upturned lugs. These terminations should be the appropriate size for the wires and should clamp both the insulation and conductor. **Statement 1002**

---



---

**Warning** When installing or replacing the unit, the ground connection must always be made first and disconnected last. **Statement 1046**

---

To connect the system ground, you require the following tools and materials:

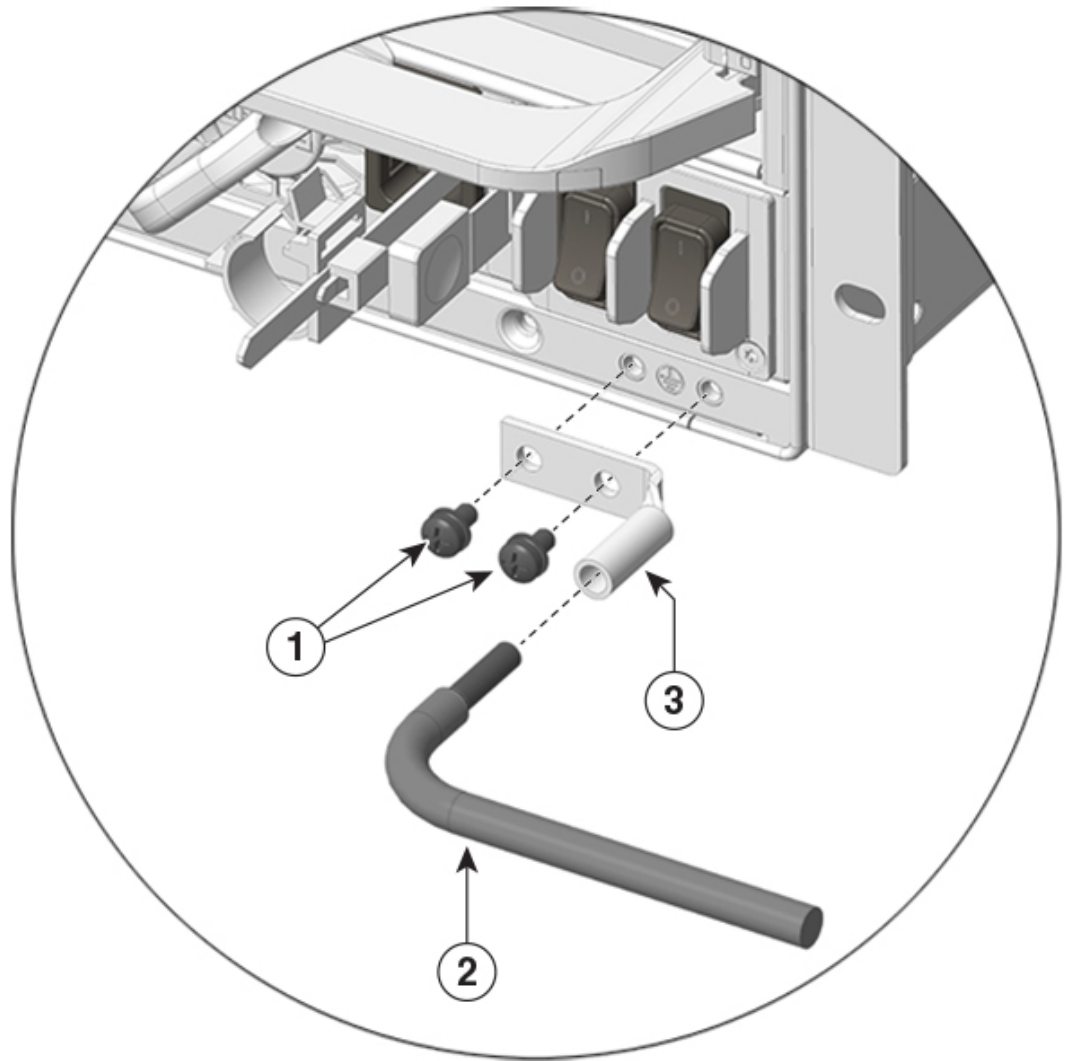
- Grounding lug—A two-hole grounding lug, which supports up to 6 AWG size. Supplied as part of the standard accessory kit.
- Grounding screws—Two M4 x 8 mm (metric) pan-head screws. Supplied as part of the standard accessory kit.
- Grounding wire—The grounding wire should be sized according to local and national installation requirements. Depending on the power supply and system, a 12 to 6 AWG copper conductor is required for U.S. installations. Commercially available 6-AWG wire is recommended. The length of the grounding wire depends on the proximity of the switch to proper grounding facilities.
- No. 1 Phillips screwdriver.
- Crimping tool to crimp the grounding wire to the grounding lug.
- Wire-stripping tool to remove the insulation from the grounding wire.

## Procedure

---

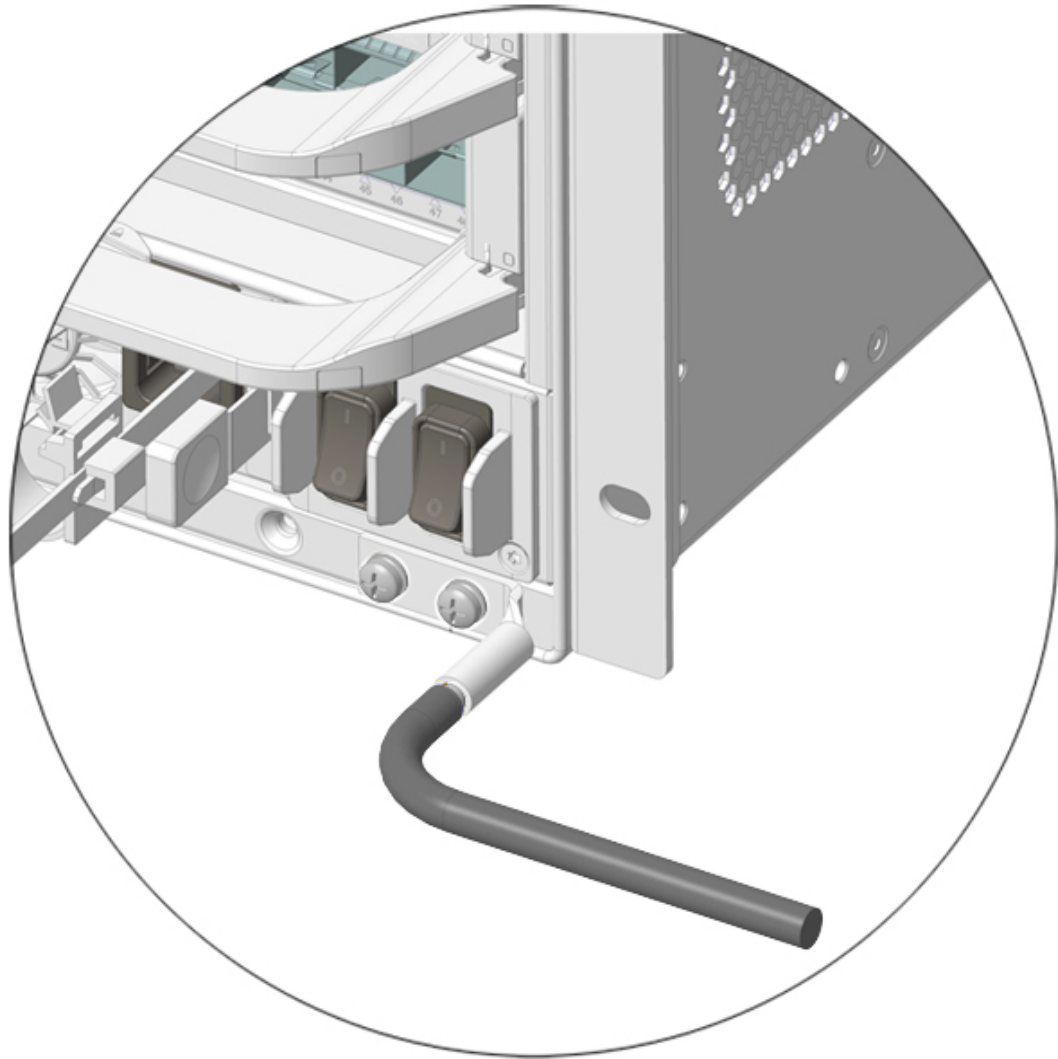
- Step 1** Use a wire-stripping tool to remove approximately 0.75 inches (19 mm) of the covering from the end of the grounding wire.
- Step 2** Insert the stripped end of the grounding wire into the open end of the grounding lug.
- Step 3** Crimp the grounding wire in the barrel of the grounding lug. Verify that the ground wire is securely attached to the ground lug.
- Step 4** Secure the grounding lug to the system ground connector with two M4 screws. Ensure that the grounding lug and the grounding wire do not interfere with other switch hardware or rack equipment.

Figure 33: Locating and Connecting System Ground



356050

1	M4 screws to secure the lug to the connector	3	Grounding lug
2	Stripped end of the grounding wire inserted into the open end of the grounding lug		

*Figure 34: System Ground Connected*

356051

- Step 5** Prepare the other end of the grounding wire, and connect it to an appropriate grounding point in your site to ensure adequate earth ground for the switch.
- 

## Attaching an ESD Strap

After you install the system ground lug, follow these steps to correctly attach the ESD wrist strap:

### Procedure

---

- Step 1** Attach the ESD wrist strap to bare skin as follows:



- a) If you are using the ESD wrist strap supplied with the FRUs, open the wrist strap package and unwrap the ESD wrist strap. Place the black conductive loop over your wrist and tighten the strap such that it touches your bare skin well.
- b) If you are using an ESD wrist strap equipped with an alligator clip, open the package and remove the ESD wrist strap. Locate the end of the wrist strap that attaches to your body and secure it to your bare skin.

**Step 2** Grasp the spring or alligator clip on the ESD wrist strap and momentarily touch the clip to a bare metal spot (unpainted surface) on the rack. We recommend that you touch the clip to an unpainted rack rail so that any built-up static charge is then safely dissipated to the entire rack.

**Step 3** Attach either the spring clip or the alligator clip to the ground lug screw as follows:

- a) If you are using the ESD wrist strap that is supplied with the FRUs, squeeze the spring clip jaws open, position the spring clip to one side of the system ground lug screw head, and slide the spring clip over the lug screw head so that the spring clip jaws close behind the lug screw head.

**Note** The spring clip jaws do not open wide enough to fit directly over the head of the lug screw or the lug barrel.

- b) If you are using an ESD wrist strap that is equipped with an alligator clip, attach the alligator clip directly over the head of the system ground lug screw or to the system ground lug barrel.

When handling modules, follow these guidelines:

- Handle carriers using the available handles or edges only; avoid touching the printed circuit boards or connectors.
- Place a removed component boardside up on an antistatic surface or in a static shielding container. If you plan to return the component to the factory, immediately place it in a static shielding container.
- Never attempt to remove the printed circuit board from the metal carrier.

**Caution** For safety, periodically check the resistance value of the antistatic strap. The measurement should be between 1 and 10 megohm (Mohm).

---

## Verifying the Switch Chassis Installation

To verify the switch chassis installation, perform these steps:

### Procedure

---

- Step 1** Verify that the ejector levers of each module are fully closed (parallel to the faceplate) to ensure that the supervisor and all the line cards are fully seated in the backplane connectors.
- Step 2** Verify that all empty module slots and power supply bays have blanks installed properly. The blanks optimize the air flow through the chassis and contain EMI.

**Warning Statement 1029**—Blank Faceplates and Cover Panels

Blank faceplates and cover panels serve three important functions: they reduce the risk of electric shock and fire, they contain electromagnetic interference (EMI) that might disrupt other equipment, and they direct the flow of cooling air through the chassis. Do not operate the system unless all cards, faceplates, front covers, and rear covers are in place.

**Step 3** Turn on the power supply switches to power up the system. During the power-up sequence, the system performs a series of bootup diagnostic tests.

**Note** The switch is designed to boot up in less than 30 minutes, provided that the neighboring devices are in fully operational state.

---

**What to do next**

Additional system diagnostic tests are also available. These tests allow you to perform a complete sanity check on the system prior to inserting the system into your network and to monitor the health of the system while the system is running.



---

**Tip** When prestaging systems in a nonproduction environment, we recommend that you run all the diagnostic tests, including the disruptive tests, to prescreen the systems for failures, if any.

---



## CHAPTER 4

# Installing the Fan Tray

---

- [Guidelines for Removing and Installing a Fan Tray, on page 69](#)
- [Removing a Fan Tray, on page 69](#)
- [Installing a Fan Tray, on page 76](#)
- [Verifying Fan Tray Installation, on page 79](#)

## Guidelines for Removing and Installing a Fan Tray

Before removing or installing a fan tray ensure you read and follow the guidelines and safety warnings listed here.



---

**Caution**

When removing the fan tray, keep your hands and fingers away from the spinning fan blades. Let the fan blades completely stop before you remove the fan tray.

---



---

**Warning**

Only trained and qualified personnel should be allowed to install, replace, or service this equipment. **Statement 1030**

---

## Removing a Fan Tray

The following sections explain the steps to remove a fan tray in a Cisco Catalyst 9600 Series switches.

## Information About Replacing a Fan Tray

### Online Insertion and Removal

While the fan tray is designed to be removed and installed while the system is operating (powered on) without presenting an electrical hazard or damage to the system, there is a time constraint when you remove and replace the fan tray in a system that is powered on.




---

**Caution** The system can safely run without a fan tray only for a few minutes, until the critical temperature threshold is exceeded. Watch for any alarms triggered in software. After the critical temperature threshold is exceeded without sufficient cooling, the system shuts down if the alarm is not cleared.

---

When the fan tray is removed and replaced in a non-operating system, there is no time constraint.

### Following the Correct Removal and Replacement Procedure

When you order a spare, only the fan tray is shipped. The connector is not shipped with a spare and you have to use the one originally available with the fan tray assembly.

You can remove and replace the fan tray from the front or the rear. When removed from the front of the chassis, only the fan tray is removed. When removed from the rear, the entire fan tray assembly (including the connector) is removed.

Removal and replacement from the front is suited to situations where access to the rear of the system is restricted. For instance, where the installation is in a closet. Removal and replacement from the rear is suited to situations where input and output cables are routed across the front panel, limiting access to the front panel of the fan tray.

Follow the corresponding removal and replacement procedures.

## Enabling the Service Mode Before Removing the Fan Tray

This task describes how you can enable the service mode before removing the fan tray from the chassis. Enabling the service mode pushes the fans to operate at full speed and cool down the system sufficiently, allowing the system to sustain temperatures for the duration of servicing.

In a system that is operational, this applies to removal or replacement procedures from the front and the rear. You do not have to enable this mode if you are removing and replacing the fan tray in a system that is not powered on.




---

**Warning** Only trained and qualified personnel should be allowed to install, replace, or service this equipment. **Statement 1030**

---

Starting in the privileged EXEC mode, enter the following command:

```
Device#test platform hardware chassis fantray service-mode on
fantray service mode on
```

The system automatically turns off the service mode after 10 minutes. This cools down the chassis sufficiently for the service duration.

To turn off the service mode before this system-allotted duration, enter the following command:

```
Device#test platform hardware chassis fantray service-mode off
fantray service mode off
```

## Removing the Fan Tray from the Front of the Chassis

### Before you begin

- Read [Guidelines for Removing and Installing a Fan Tray, on page 69](#).
- Enable the service mode on the chassis, if you are performing this task in a system that is powered on.
- Ensure that you have the following tools and accessories available:
  - Phillips-head screwdriver
  - Anti-static mat

### Procedure

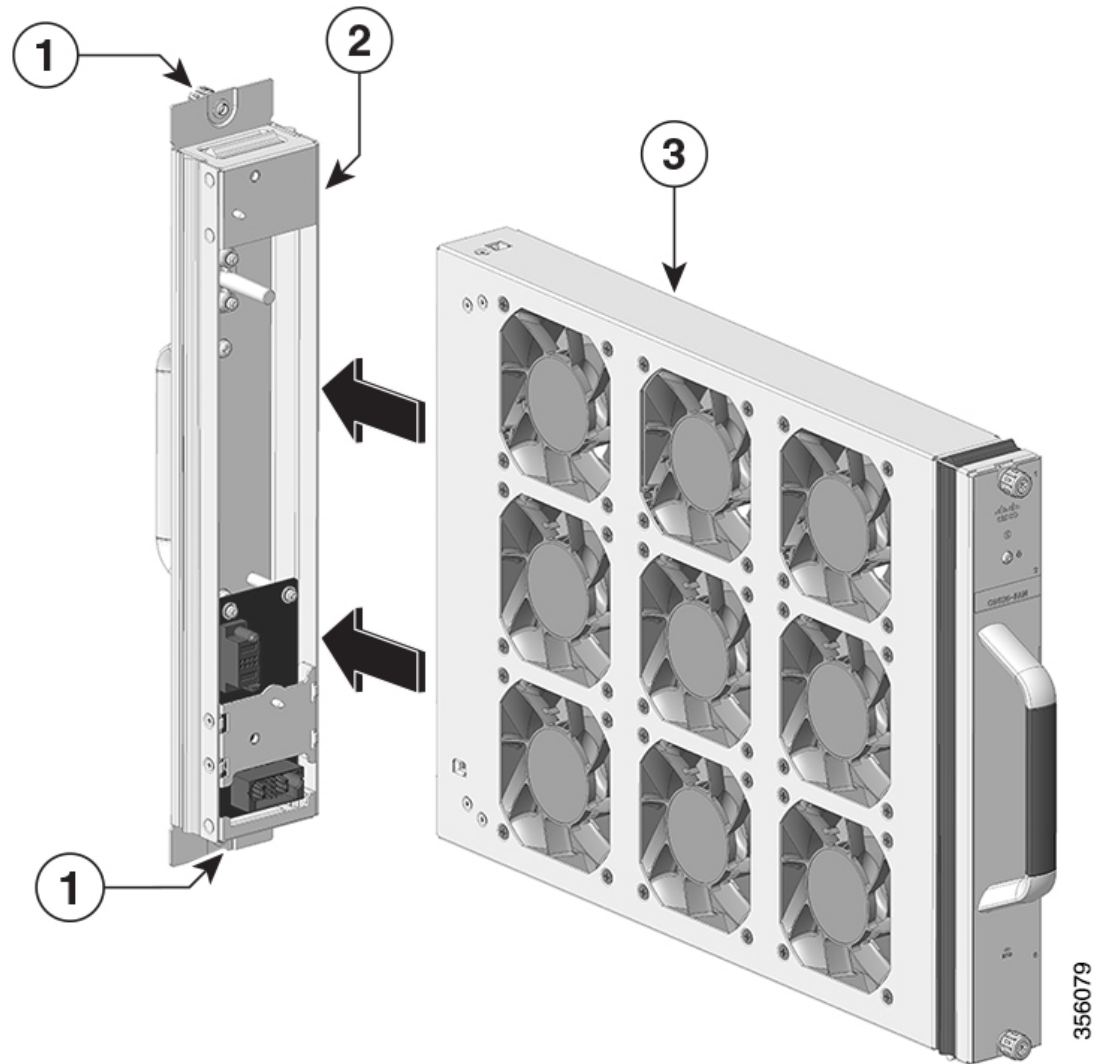
---

**Step 1** Keep the replacement fan tray ready for installation.

**Important** When you remove and replace the fan tray in a system that is powered on, there is a time constraint. The system can safely run without a fan tray only for 2 minutes. So, it is important to complete this first step and its sub-steps before you remove the fan tray from the front of the chassis.

- a) Remove the replacement fan tray from the shipping packaging.
- b) Use the Phillips-head screwdriver and loosen the two captive installation screws on the front panel of the replacement fan tray (the side with the fan STATUS LED), to detach it from the connector.

Figure 35: Detaching the Connector from the Fan Tray



1	Captive installation screws on the front of the fan tray assembly	3	Fan tray
2	The connector in the rear, separated from the fan tray	-	-

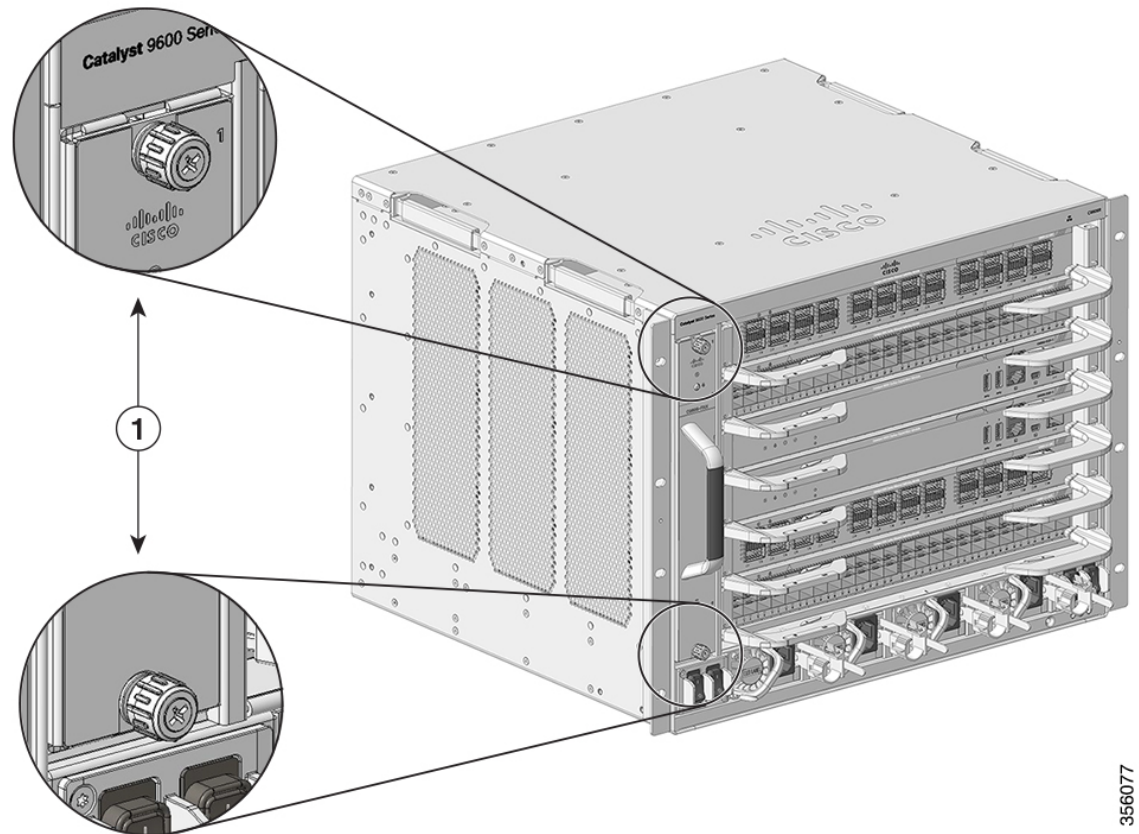
The connector is not used or replaced when installed from the front. The connector can be scrapped or stored for future use.

- c) Place the replacement fan tray on an anti-static mat and within arm's reach.

## Step 2

Proceed with removing the fan tray from the chassis. Loosen the two captive installation screws on the front panel of the fan tray (the side with the fan STATUS LED).

Figure 36: Removing the Captive Installation Screws



356077

1	Captive installation screws on the front of the fan tray assembly in the chassis
---	--

- Step 3** Grasp the fan tray handle and slide the fan tray half-way out of the bay. Gently move it from side to side, if necessary, to unseat it from the backplane.
- Step 4** Wait for the fan blades to stop spinning; place your other hand underneath to support the bottom of the fan tray and then remove the fan tray completely.
- Only the fan tray is removed from the chassis (excluding the connector).

#### What to do next

Set the removed fan tray aside and proceed with installing the replacement or spare fan tray.

## Removing the Fan Tray from the Rear of the Chassis

When you remove the fan tray from the rear, the fan tray assembly is removed. This includes the fan tray and the connector.

**Before you begin**

- Read [Guidelines for Removing and Installing a Fan Tray](#), on page 69.
- Enable the service mode on the chassis, if you are performing this task in a system that is powered on.
- Ensure that you have the following tools and accessories available:
  - Phillips-head screwdriver
  - Anti-static mat

**Procedure**

---

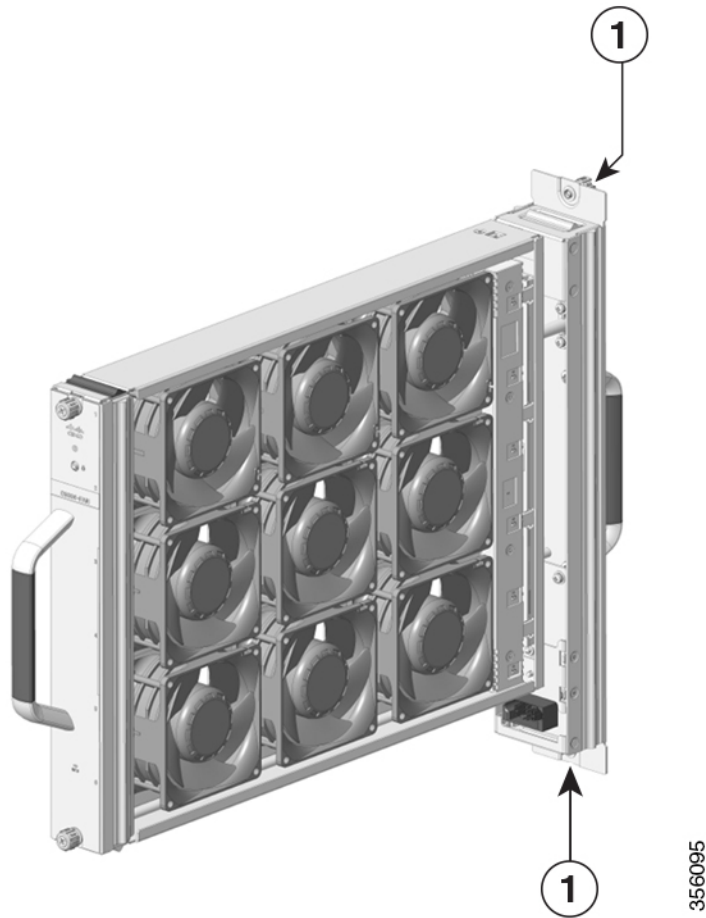
**Step 1**

Keep the replacement fan tray ready by removing it from the shipping packaging. Place it on an anti-static mat and within arm's reach. Do not detach the connector module.

**Important** When you remove and replace the fan tray in a system that is powered on, there is a time constraint. The system can safely run without a fan tray only for 2 minutes. So it is important to complete this first step before you remove the fan tray from the rear of the chassis.



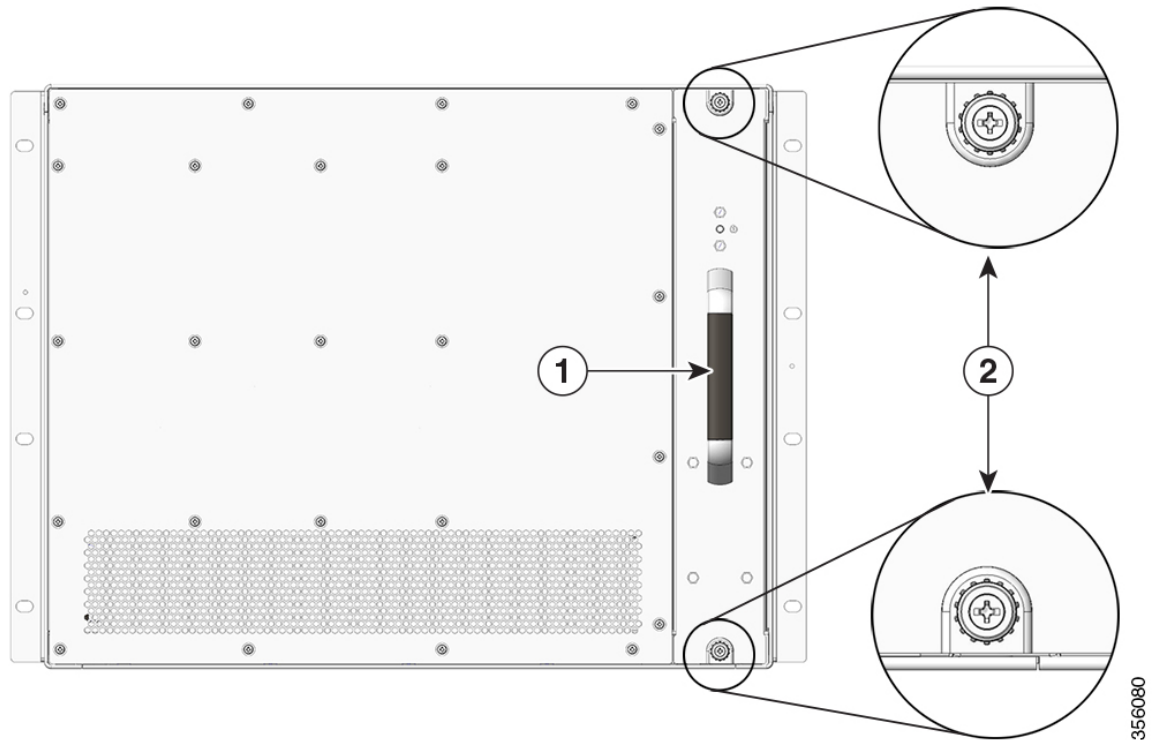
Figure 37: Fan Tray with the Connector



1	Fan tray with the connector
---	-----------------------------

- Step 2** Proceed with removing the fan tray from the chassis. Loosen the two captive installation screws on the rear panel of the fan tray.

Figure 38: Captive Installation Screws on the Rear Panel



1	Rear fan tray handle	2	Captive installation screws on the rear panel. <b>Note</b> Loosen to uninstall the fan tray assembly from the rear.
---	----------------------	---	--

**Step 3** Grasp the fan tray handle and slide the fan tray assembly half-way out of the bay.

**Step 4** Wait for the fan blades to stop spinning; place your other hand underneath to support the bottom of the fan tray and then remove the fan tray assembly completely.

#### What to do next

Set the removed fan tray aside and proceed with installing the replacement or spare fan tray.

## Installing a Fan Tray

The following sections provide information about installing a fan tray in Cisco Catalyst 9600 Series switches.

## Installing the Fan Tray from the Front Panel of the Chassis

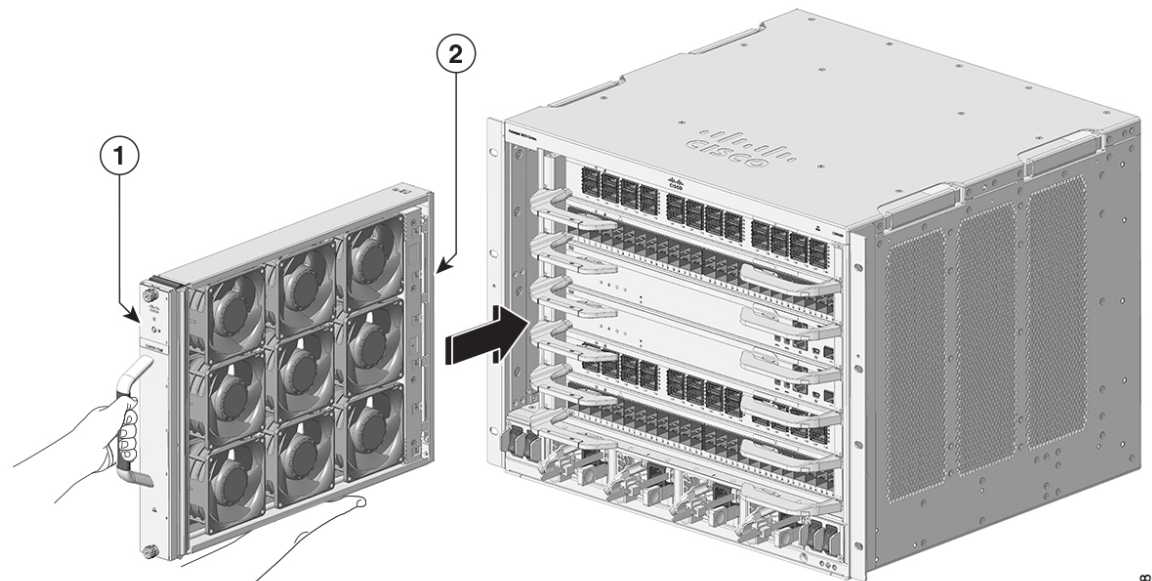
### Before you begin

- Read [Guidelines for Removing and Installing a Fan Tray, on page 69](#).
- Enable the service mode on the chassis, if you are performing this task in a system that is powered on.
- Ensure that you have the following tools and accessories available:
  - Phillips-head screwdriver
  - Anti-static mat

### Procedure

- Step 1** Hold the fan tray assembly with the fans facing to the right.
- Step 2** Place the fan tray into the fan tray slot so it rests on the chassis, and then lift the fan tray up slightly, aligning the top and bottom guides.

*Figure 39: Inserting the Fan Tray from the Front of the Chassis*



356078

1	Front side of the fan tray	2	Fan tray without the connector
---	----------------------------	---	--------------------------------

- Step 3** Slide the fan tray into the chassis until the two captive installation screws make contact with the chassis.
- Step 4** Tighten the two captive installation screws on the front, to secure the fan tray assembly in the chassis.

**What to do next**

Verify that you have installed the fan tray correctly. See [Verifying Fan Tray Installation, on page 79](#).

## Installing the Fan Tray from the Rear of the Chassis

**Before you begin**

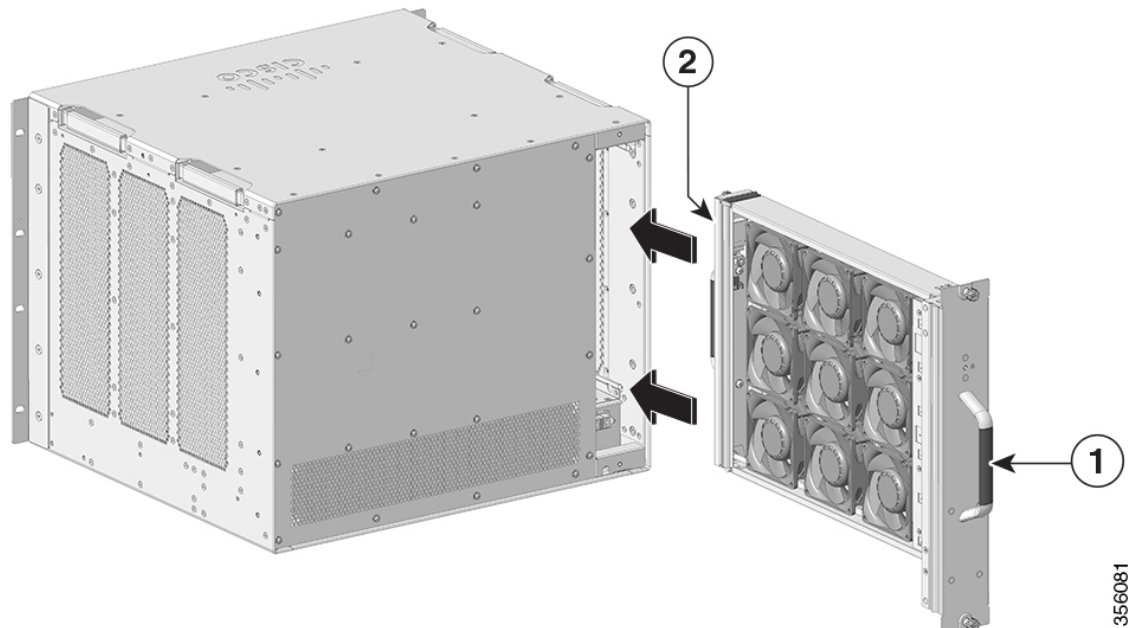
- Read [Guidelines for Removing and Installing a Fan Tray, on page 69](#).
- Enable the service mode on the chassis, if you are performing this task in a system that is powered on.
- Ensure that you have the following tools and accessories available:
  - Phillips-head screwdriver
  - Anti-static mat

**Procedure**

**Step 1** On the replacement fan tray assembly, ensure that the two screws securing the fantray to the connector (on the side with the fan STATUS LEDs) are tight. Be careful not to overtighten the screws.

**Step 2** Hold the fan tray assembly such that the side with the STATUS LED is inserted first.

**Figure 40: Inserting the Fan Tray from the Rear of the Chassis**



356081

1	Release handle on the front of the fan tray.  <b>Note</b> Ensure that the captive installation screws on this side are tightened before sliding the fan tray in.	2	Rear panel of the fan tray.  <b>Note</b> Tighten the captive installation screws on this side, after sliding the fan tray in.
---	--	---	---

- Step 3** Place the fan tray into the fan tray bay so it rests on the chassis, and then lift the fan tray up slightly, aligning the top and bottom guides.
- Step 4** Slide the fan tray into the chassis until the two captive installation screws make contact with the chassis.
- Step 5** Tighten the two captive installation screws on the rear and secure the fan tray assembly in the chassis.

#### What to do next

Verify that you have installed the fan tray correctly. See [Verifying Fan Tray Installation, on page 79](#).

## Verifying Fan Tray Installation

To verify that the new fan tray is installed correctly and is operating properly, follow these steps:

#### Before you begin

To check the operation of the fans, you should have powered up the chassis.

#### Procedure

- Step 1** Listen for the fans; you should immediately hear them operating. If you do not hear them, ensure
- That the fan tray is inserted completely in the chassis
  - That the faceplate is flush with the chassis panel.
  - That the captive installation screws have been tightened sufficiently.
- Important** If the fan tray is not installed correctly, the fans may not run at all, or they may run at full speed. When the fan tray operates at full speed, increased noise levels may be expected.
- Step 2** Check if the fan tray LED is lit and is green.
- Step 3** If after several attempts the fans do not operate, or if you experience trouble with the installation (for instance, if the captive installation screws do not align with the chassis holes), contact the Cisco TAC for assistance.





## CHAPTER 5

# Installing a Power Supply Unit

---

- [Required Tools and Equipment](#), on page 81
- [Removing and Installing Power Supply Modules](#), on page 81
- [Connecting to a Power Source](#), on page 88
- [Verifying the Power Supply Installation](#), on page 92
- [Removing and Installing Power Supply Blanks](#), on page 92
- [Finding the Serial Number](#), on page 96

## Required Tools and Equipment

Obtain these tools:

- A Phillips-head screwdriver
- A 10-mm torque driver (with a 3-inch shaft, at a minimum)
- Wire-stripping tool
- Wire crimping tool

## Removing and Installing Power Supply Modules

The chassis supports field-replaceable and hot-swappable AC-input and DC-input power supply modules. You can install a mix of AC-input and DC-input modules in the chassis. This section describes how to remove and install both kinds of modules

- In a redundant mode, you do not have to power down the switch to replace or upgrade the power supplies.
- In the combined mode, the module is still hot-swappable as long as the difference between total output power and the total used power is greater than the capacity of the module being removed.

Total output power – Total used > Capacity of power supply module being removed.



**Warning** When stranded wiring is required, use approved wiring terminations, such as closed-loop or spade-type with upturned lugs. These terminations should be the appropriate size for the wires and should clamp both the insulation and conductor.

**Statement 1002**



**Warning** **Statement 1003—DC Power Disconnection**

To reduce risk of electric shock or personal injury, disconnect DC power before removing or replacing components or performing upgrades.



**Warning** This product relies on the building's installation for short-circuit (overcurrent) protection. Ensure that the protective device is rated not greater than these values for US and EU:

- 20A circuit breakers for AC-input power supply.
- 60A DC-rated circuit breakers for each input for safety purposes - irrespective of whether the inputs are power from a single or separate DC sources.

**Statement 1005**



**Warning** **Statement 1022—Disconnect Device**

To reduce the risk of electric shock and fire, a readily accessible disconnect device must be incorporated in the fixed wiring.



**Warning** Use copper conductors only.

**Statement 1025**



**Warning** Only trained and qualified personnel should be allowed to install, replace, or service this equipment.

**Statement 1030**



**Warning** No user-serviceable parts inside. Do not open.

**Statement 1073**





**Warning** **Statement 1086**—Replace Cover on Power Terminals

Hazardous voltage or energy may be present on power terminals. To reduce the risk of electric shock, make sure the power terminal cover is in place when the power terminal is not being serviced. Be sure uninsulated conductors are not accessible when the cover is in place.

## Removing a Power Supply Module

### Before you begin



**Warning** Only trained and qualified personnel should be allowed to install, replace, or service this equipment. **Statement 1030**

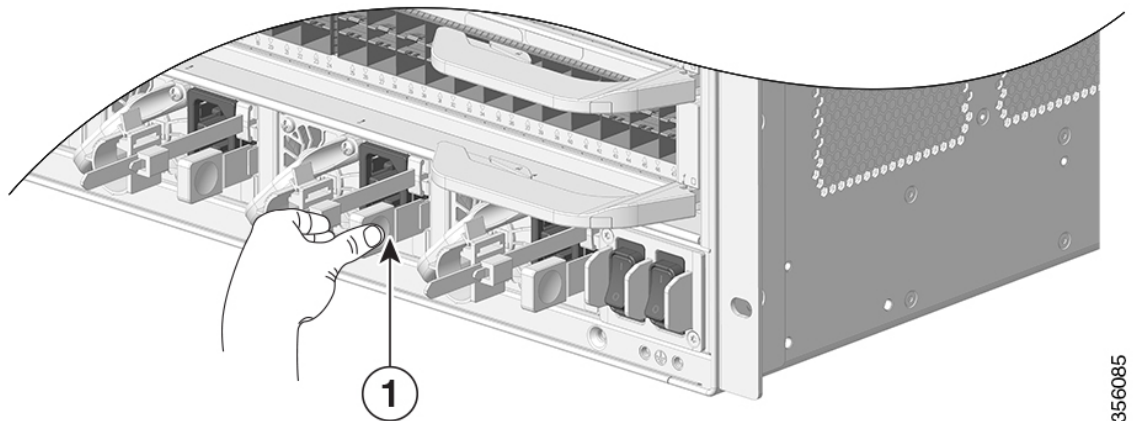


**Warning** No user-serviceable parts inside. Do not open. **Statement 1073**

### Procedure

- Step 1** Turn the power switch of the designated power supply module to OFF (0) position
- Step 2** Loosen and remove the retainer strip that is around the power cord.
- Step 3** Remove the power cord from the power receptacle on the power supply.
- Step 4** Press the release latch at the right side of the power supply module inwards.

*Figure 41: Detaching the Power Supply Module from the Slot*

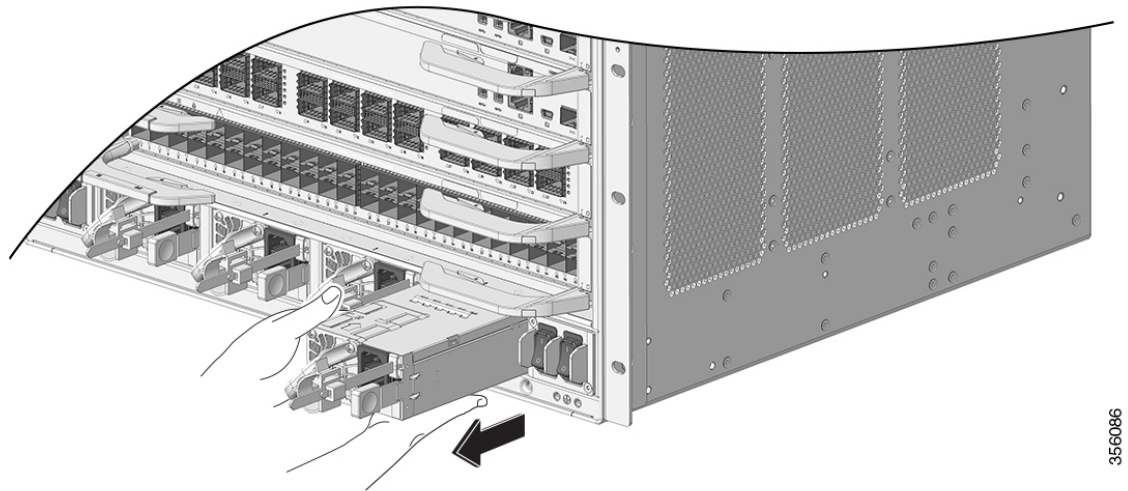


356085

1	Release latch
---	---------------

- Step 5** Grasp the power supply module handle with one hand; place your other hand underneath to support the bottom of the power supply. Slide the power supply module out fully.

*Figure 42: Sliding the Power Supply Module Out*



356086

**Caution** Do not leave any power supply slot open for any amount of time while the system is powered up. Before inserting a new power supply unit, for instance, when replacing the unit, ensure that there are no foreign, conductive or other objects, or debris in the slot.

**Warning** In the course of its operation the system may require more than one power supply installed and supplying power. Should it become necessary to remove an active power supply unit from the system, consult the user manual for proper system administration of available power. In order to safely de-energize the power supply unit, the input power should first be turned off and the power cable physically disconnected from the unit. The unit must then be removed from the slot and stowed safely away in a proper antistatic bag. Care must be taken not to touch any of the exposed pins from the backplane connector. When a replacement power supply unit is to be installed, its power switch must always be in the OFF state and no input power cable be installed prior to inserting it into the slot. After the unit is seated, the input power cable may then be installed and fastened securely before switching on the power supply. **Statement 1028**

### What to do next

Set the power supply aside and proceed with installing the new or replacement power supply module. Install blank covers in all power supply bays that are to remain empty (C9600-PWR-BLANK). For information about installing blank covers, see [Removing and Installing Power Supply Blanks, on page 92](#).

# Installing a Power Supply Module

## Before you begin



---

**Warning** Only trained and qualified personnel should be allowed to install, replace, or service this equipment. **Statement 1030**

---



---

**Warning** No user-serviceable parts inside. Do not open. **Statement 1073**

---

Ensure that you have installed the cable guide before you begin the procedure. This is to properly guide and arrange the power cords that you will attach as part of the installation.

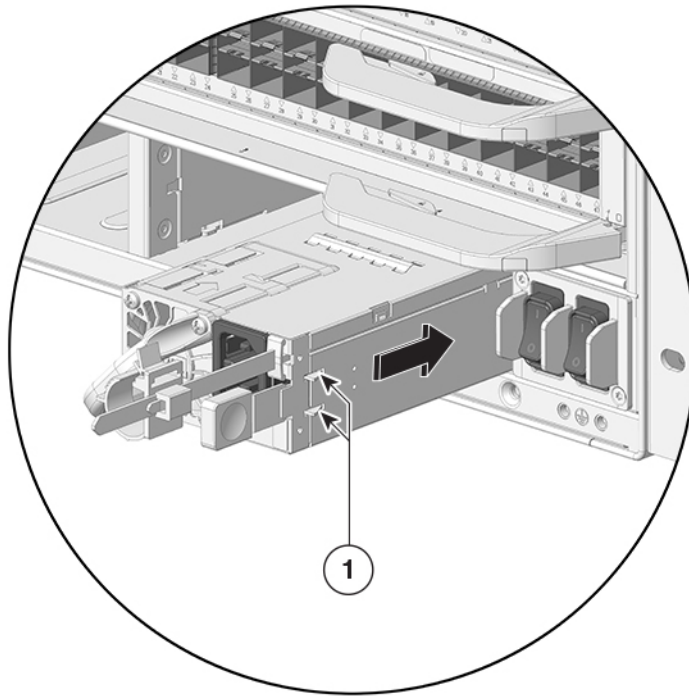
## Procedure

---

- Step 1** Remove the replacement power supply from its shipping packaging.
- Step 2** Verify that the power switch of the replacement power supply is in the OFF (0) position.
- Step 3** If installed, remove the blank power supply cover from the empty power supply bay. For information about removing blank covers, see [Removing and Installing Power Supply Blanks, on page 92](#). Save the blank cover for future use.
- Step 4** Grasp the power supply handle with one hand and place your other hand underneath to support the bottom of the power supply. Slide the power supply all the way into the power supply bay. Make sure that the power supply is fully seated in the bay.

When correctly installed, the latch on the power supply locks-in the module, to avoid accidental removal of the module.

*Figure 43: Inserting the Power Supply into the Power Supply Bay*



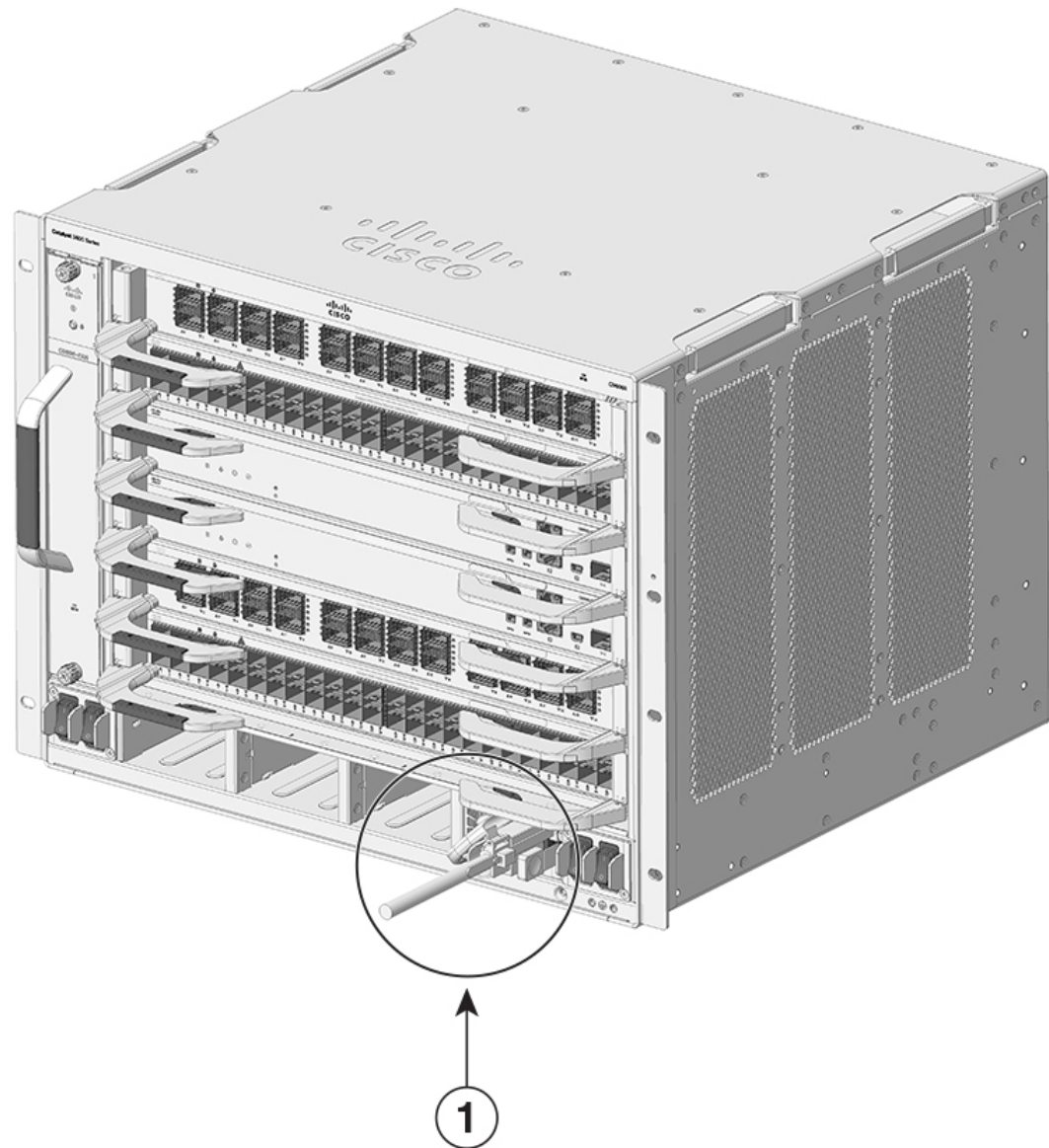
356082

1	Power supply latches, which click into place
---	--

**Step 5** Verify that all site power and grounding requirements have been met.

**Step 6** Verify that you have the correct power cord for your location and power supply rating and only then plug the power cord connector into the power supply receptacle.

Figure 44: Plugging in the Power Cord



356084

1	Power cord plugged into the receptacle
---	--

**Step 7**

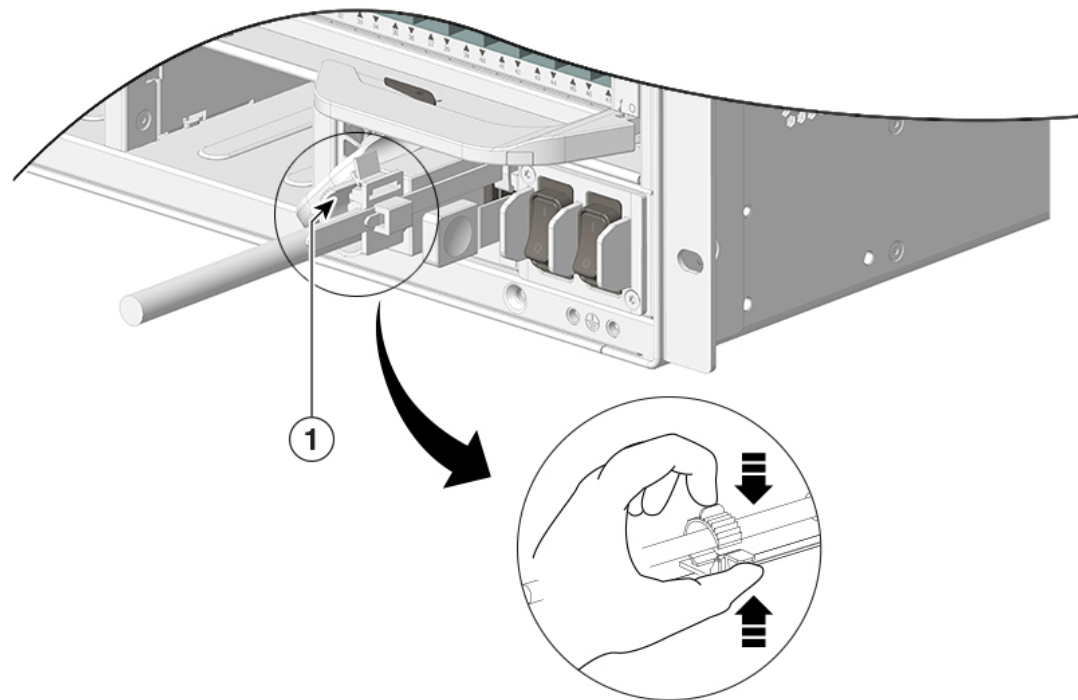
Follow the steps to install the power cord retainer, to hold it in place and avoid accidental removal.

- a) Fix the strap in the power cord retainer to the power supply module, to hold the clamp in place.
- b) Slide the retainer clamp around the power cord and position the retainer closest to the power supply.

Depending on the width of the power cord, adjust the size of the retainer clamp, if required.

- c) Press the tabs on the retainer clamp towards each other to secure the power cord.

Figure 45: Installing the Power Cord Retainer



356083

1	Power supply fully inserted into the chassis; power cord and retainer strapped into place.
---	--

**Step 8** Set the power switch to the ON (I) position

#### What to do next

Connect the power supply to the power source.

## Connecting to a Power Source

The following sections provide information about connecting the chassis to an AC and DC power source.

### Connecting to an AC Power Source

To connect to a power source, follow these steps:



**Warning** Take care when connecting units to the supply circuit so that wiring is not overloaded. **Statement 1018**

### Procedure

---

- Step 1** Prior to connecting the power supply to a power source, ensure that the chassis is properly grounded.
- Step 2** Plug the power cable into the power supply.
- Step 3** Plug the other end of the power cable into a power source supplied by the data center.
- Note** When using redundant mode, connect each power supply to a separate power source.
- Step 4** Verify that the power supply is receiving power by checking that the LED is on and is green. For more information about the power supply LEDs and the conditions that they indicate, see [Power Supply Modules LEDs, on page 114](#).

When you first activate the power supply, you can verify the functionality of the LED by checking that LED turns on for a couple of seconds. If the LED is flashing amber or green, check the power connections on the power supply and the power source.

---

## Connecting to a DC Power Source

To connect the DC power supply directly to one or two DC power sources, follow these steps:



---

**Warning** **Statement 1086**—Replace Cover on Power Terminals

Hazardous voltage or energy may be present on power terminals. To reduce the risk of electric shock, make sure the power terminal cover is in place when the power terminal is not being serviced. Be sure uninsulated conductors are not accessible when the cover is in place.

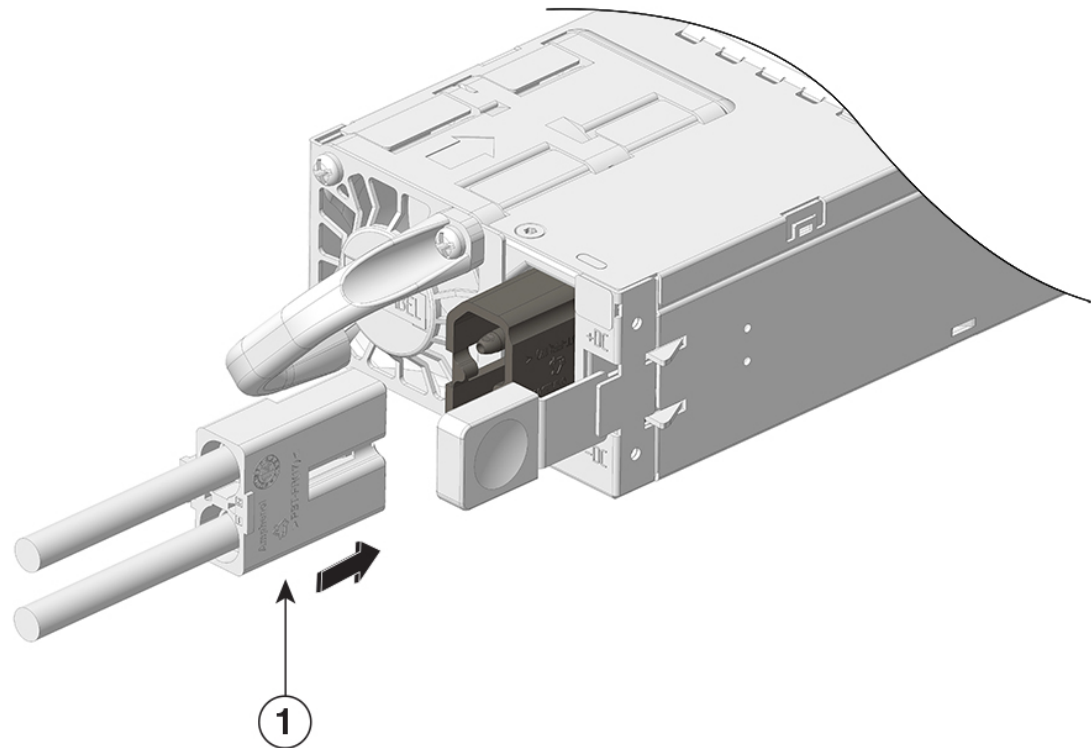
---

### Procedure

---

- Step 1** Prior to connecting the power supply to a power source, ensure that the chassis is properly grounded.
- Step 2** Plug the DC power cable into the DC power receptacle on the power supply module.

Figure 46: Plugging in the DC Power Cable



356094

1	Power Cable
---	-------------

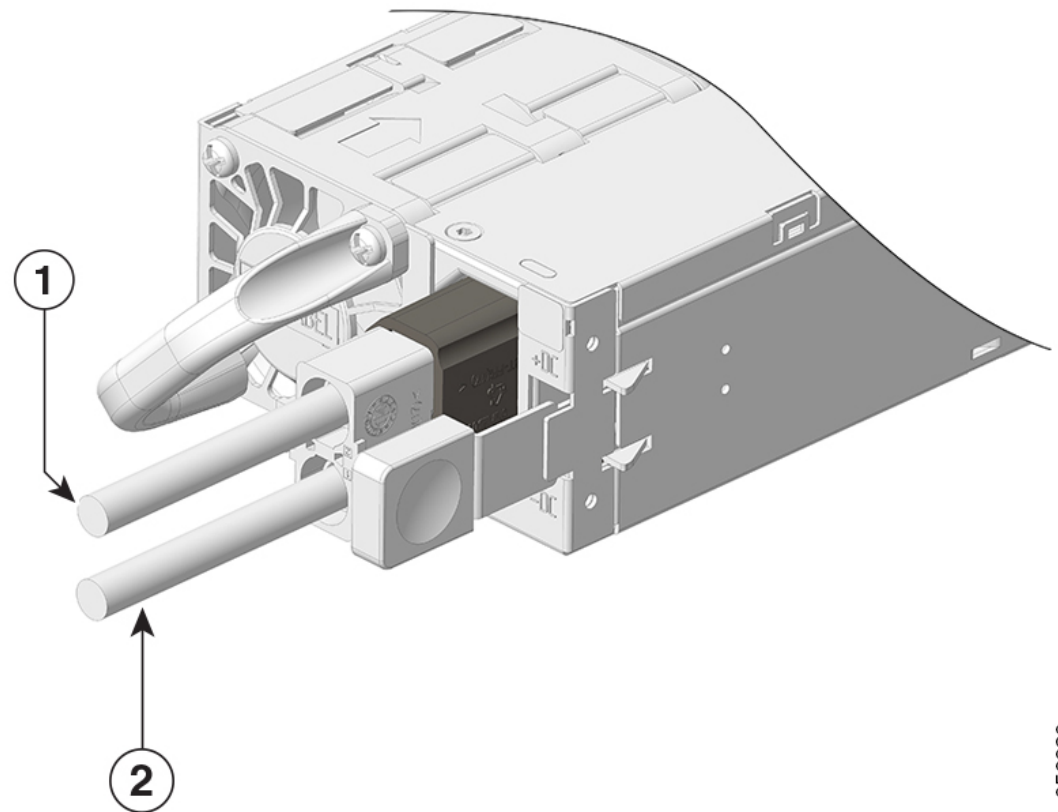
**Step 3** Turn off the power at the circuit breakers for the portions of the DC grid power that you are connecting to and verify that all of the LEDs on the DC grid power supplies are off.

**Step 4** Install the two cables from the DC power cable to a DC power source as follows:

- a) If the unconnected end of each power cable is not stripped of its insulation for the last 0.75 inches (19 mm), use wire strippers to remove that amount of insulation.
- b) Attach the negative cables to the negative terminals of a DC power source, and attach the positive cables to the positive terminals of the same power source.



Figure 47: Attaching the Cable to the Power Source



356093

1	Positive terminal	2	Negative terminal
---	-------------------	---	-------------------

**Note** If you are using combined power mode or power supply redundancy mode, connect all the power supplies in the chassis to the same power source. If you are using input source redundancy mode or full redundancy mode, connect half the power supplies to one DC power source and the other half of the power supplies to another DC power source.

**Step 5** Verify that the power supply is receiving power by checking that the LED is on and is green.

When you first activate the power supply, you can verify the functionality of the LED by checking that LED turns on for a couple of seconds. If the LED is flashing amber or green, check the power connections on the power supply and the power source.

## Verifying the Power Supply Installation

### Procedure

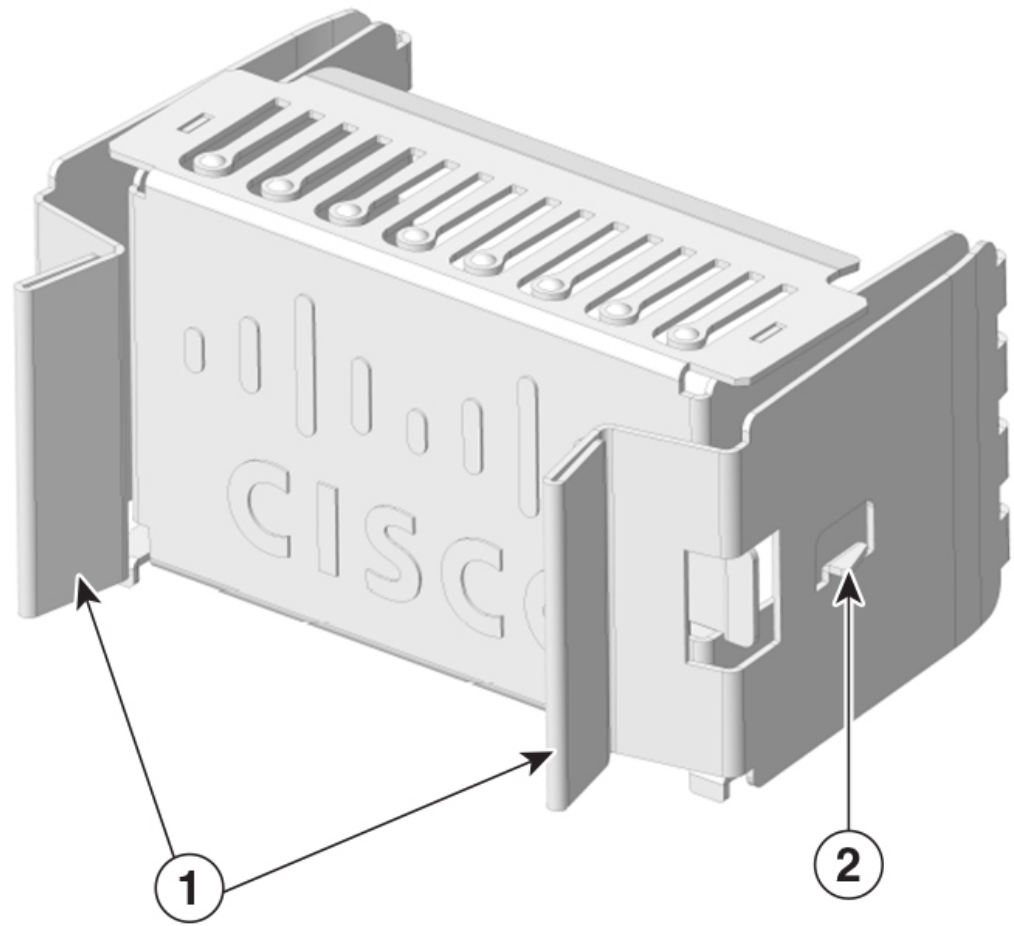
---

- Step 1** Verify the power supply operation by checking the power supply's front-panel LED. See [Power Supply Modules LEDs, on page 114](#).
- Step 2** Check the power supply and system status from the system console by entering **show power** command in privileged EXEC mode.
- ```
Switch# show power
```
- Step 3** If the LEDs or **show power** command output indicate a power problem or other system problem, see the *Troubleshooting* section for more information.
- 

## Removing and Installing Power Supply Blanks

If a power supply bay in a chassis is unused, you must cover it with a power supply blank cover to maintain proper airflow through the chassis. (Part number C9606-PWR-BLANK=).

Figure 48: Front View of a Power Supply Blank Cover

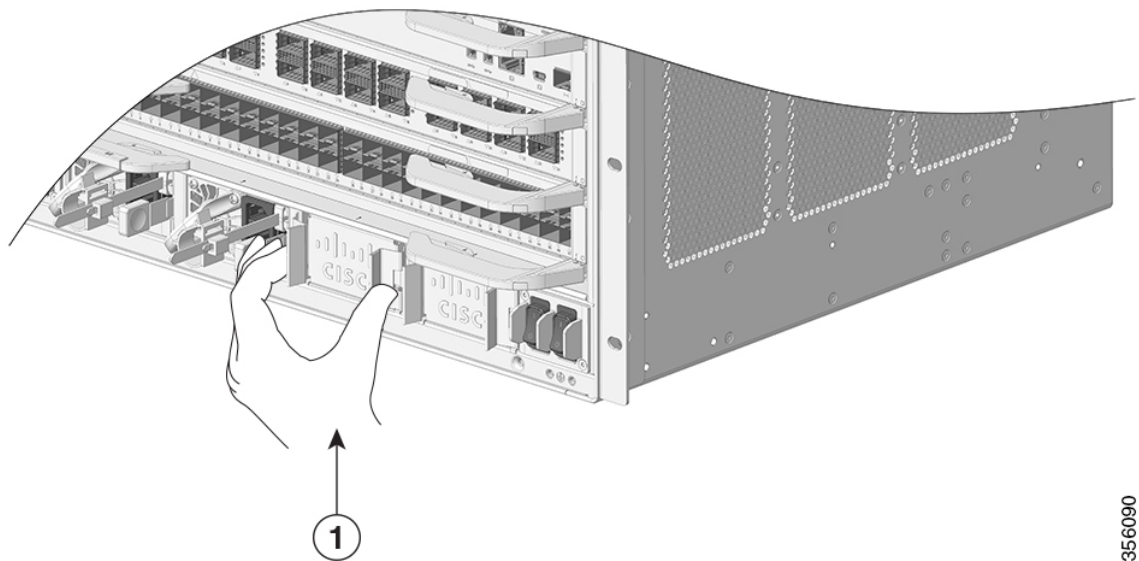


|   |                 |   |               |
|---|-----------------|---|---------------|
| 1 | Release handles | 2 | Retainer clip |
|---|-----------------|---|---------------|

### Removing a Power Supply Blank Cover

To remove the blank cover from a bay, use the release handles to hold the blank cover (with your thumb and index fingers), squeeze both the handles toward each other and slide the cover out of the bay.

Figure 49: Removing a Power Supply Blank Cover



356090

- |   |                                                     |
|---|-----------------------------------------------------|
| 1 | Release handles that are squeezed toward each other |
|---|-----------------------------------------------------|

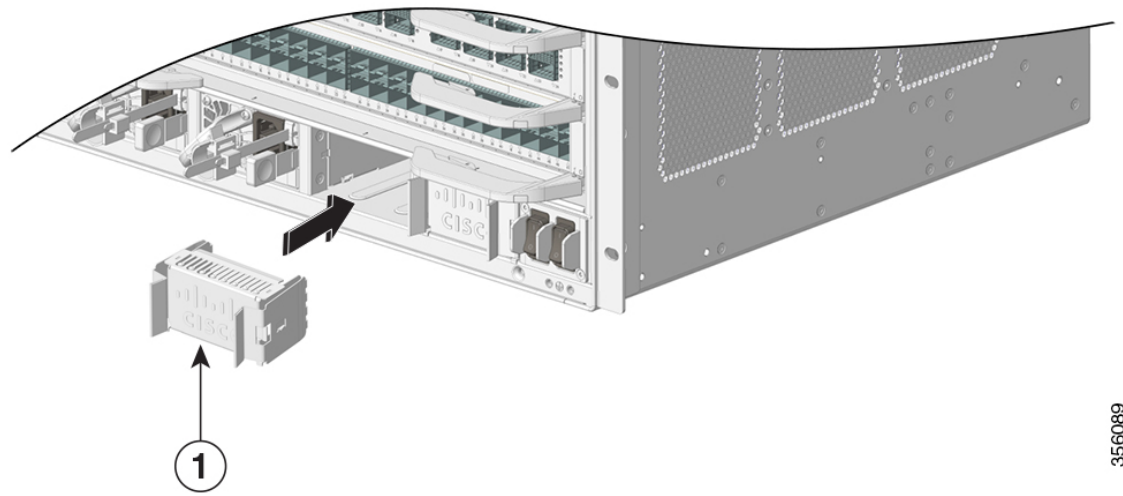


**Caution** Do not leave any power supply slot open for any amount of time while the system is powered up. Prior to inserting a new power supply unit, for instance, when replacing the unit, ensure there are no foreign, conductive or other objects, or debris in the slot.

### Installing a Power Supply Blank Cover

To install a power supply blank cover, push the blank cover straight and into the bay. You will hear retainer clips snap into place when installed correctly. You can hold the blank cover by the outside edges when you perform this task; alternatively, use the release handles to hold the blank cover.

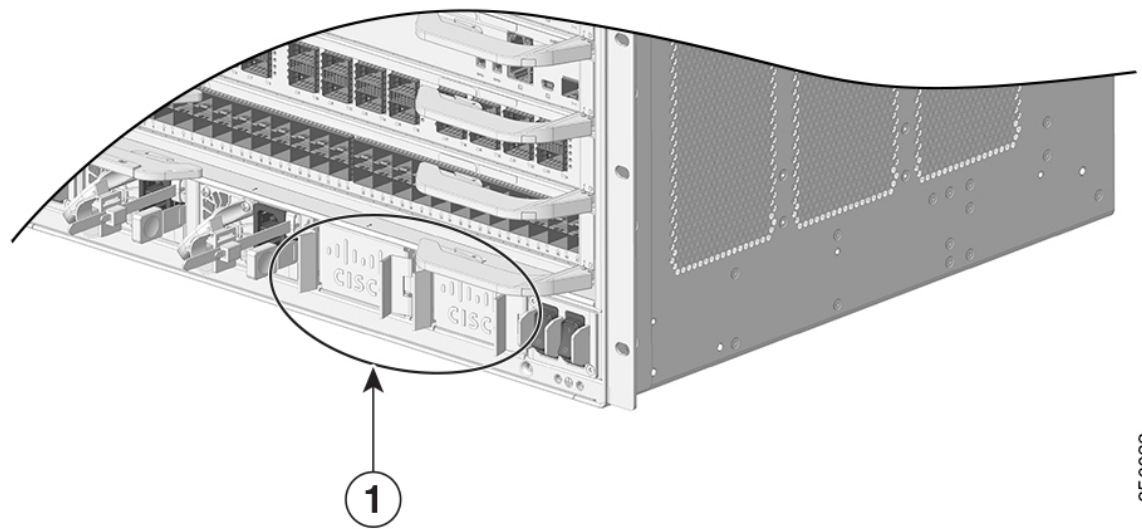
Figure 50: Installing a Power Supply Blank Cover



356089

|   |                    |
|---|--------------------|
| 1 | Power supply blank |
|---|--------------------|

Figure 51: Power Supply Blank Cover Installed



356088

|   |                                        |
|---|----------------------------------------|
| 1 | Power supply blanks after installation |
|---|----------------------------------------|

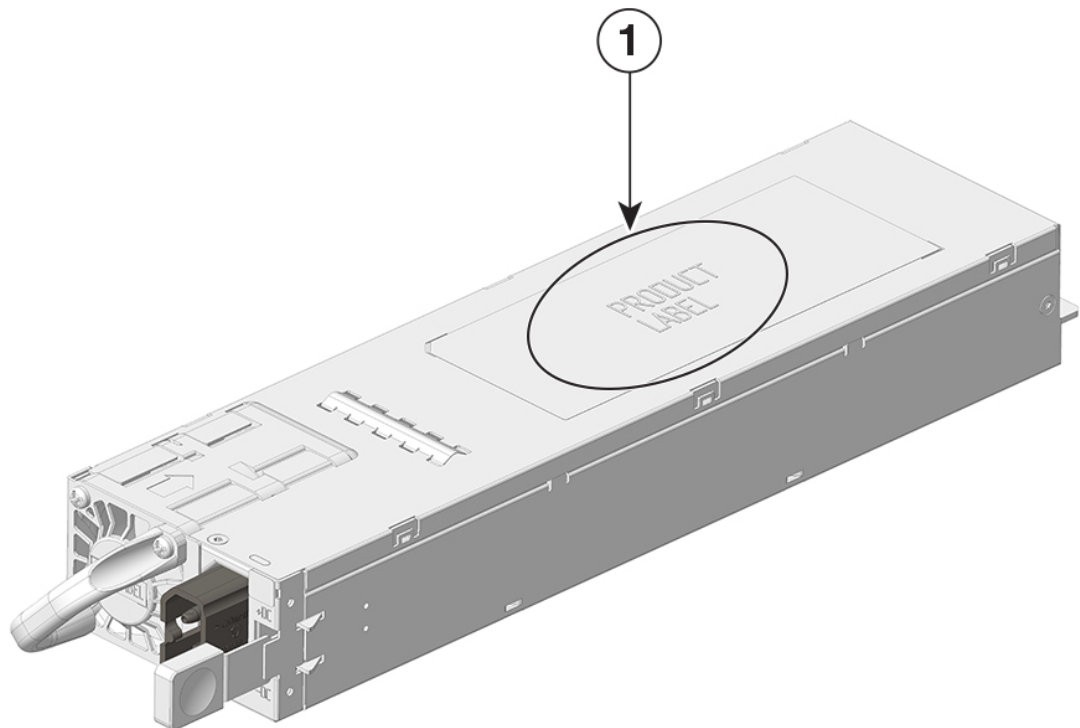


**Note** Power supply blank covers can be placed in any slot when fewer than 4 power supplies are installed in a chassis.

## Finding the Serial Number

If you contact Cisco Technical Assistance, you need to know the serial number. These figures show where the serial number is located. You can also use the **show version** privileged EXEC command to see the serial number.

**Figure 52: Serial Number on the Power Supply Module**



356092

|   |                                   |   |   |
|---|-----------------------------------|---|---|
| 1 | Power supply module serial number | - | - |
|---|-----------------------------------|---|---|



# APPENDIX **A**

## Technical Specifications

- [C9606R Switch Chassis Specifications, on page 97](#)
- [Power Supply Specifications, on page 99](#)
- [Chassis and Module Power and Heat Values, on page 109](#)
- [Weight Specifications, on page 110](#)

### C9606R Switch Chassis Specifications

**Table 8: Physical Specifications of the Chassis**

| Item                                                     | Specification                                        |
|----------------------------------------------------------|------------------------------------------------------|
| Dimensions (H x W x D)                                   | 13.95 X 17.4 X 16.1 inches (35.43 x 44.2 x 40.9 cms) |
| Rack units (RU <sup>3</sup> )                            | 8 RU                                                 |
| Weight (Chassis with two AC power supplies and fan tray) | 63.0 lb (31.31 kg)                                   |

<sup>3</sup> The chassis height is measured in rack units (RU or just U), where 1 RU or 1 U equals 1.75 in (44.45 mm).

**Table 9: Environmental Specifications of the Chassis**

| Item                                                                                | Specification                                                                                                                                                                     |
|-------------------------------------------------------------------------------------|-----------------------------------------------------------------------------------------------------------------------------------------------------------------------------------|
| Ambient temperature and altitude for normal operations <sup>4</sup>                 | <ul style="list-style-type: none"> <li>• 23° to 113°F (-5 to +45°C), up to 6,000 feet (1800 m)</li> <li>• 23° to 104°F (-5 to +40°C), up to 10,000 feet (3000 m)</li> </ul>       |
| Ambient temperature and altitude for short-term <sup>5</sup> exceptional conditions | <ul style="list-style-type: none"> <li>• 23°F to 122°F (-5°C to +50°C), up to 6,000 feet (1800 m)</li> <li>• 23°F to 122°F (-5°C to +45°C), up to 10,000 feet (3000 m)</li> </ul> |
| Nonoperating and storage temperature                                                | -40° to 167°F (-40° to 75°C)                                                                                                                                                      |

| Item                                   | Specification                                                                                                                                                                                                                              |                                                         |                |
|----------------------------------------|--------------------------------------------------------------------------------------------------------------------------------------------------------------------------------------------------------------------------------------------|---------------------------------------------------------|----------------|
| Thermal transition                     | Hot to cold—at a maximum rate of 86°F (30°C) per hour<br>Cold to hot—at maximum rate of 204.8°F (96°C) per hour                                                                                                                            |                                                         |                |
| Humidity (RH), ambient (noncondensing) | Operating, nonoperating and storage —10 to 95 percent                                                                                                                                                                                      |                                                         |                |
| Altitude (operating and nonoperating)  | -60 to 3000m (-197 to 9843 feet)                                                                                                                                                                                                           |                                                         |                |
| Sound power level (LwAD)               | LwAD—74.7 dBA<br><br>This is with four power supply modules installed and delivering 50 percent of rated output power; measured according to International Organization for Standardization (ISO) 7779 and declared according to ISO 9296. |                                                         |                |
| Airflow                                | Chassis—Right to left (when facing the front of the chassis)<br>Power supply—Front to back (forward air flow)                                                                                                                              |                                                         |                |
| Shock                                  | Operating—5G 11ms (Half-sine)<br>Nonoperating and storage— 15G 11ms (Half-sine)                                                                                                                                                            |                                                         |                |
| Sine Vibration                         | <ul style="list-style-type: none"> <li>• Operating— 0.15G (10Hz-500Hz)</li> <li>• Nonoperating and storage— 0.8G (10Hz-500Hz)</li> </ul>                                                                                                   |                                                         |                |
| Random Vibration (Operating)           | <b>Spectral Break Point Frequencies</b>                                                                                                                                                                                                    | <b>Acceleration Spectral Density</b>                    | <b>Slope</b>   |
|                                        | 2.5 – 5 Hz                                                                                                                                                                                                                                 | -                                                       | 6 db /octave   |
|                                        | 5 – 100 Hz                                                                                                                                                                                                                                 | 0.1 [(m/s <sup>2</sup> )/Hz] (0.001 g <sup>2</sup> /Hz) | -              |
|                                        | 100 – 200 Hz                                                                                                                                                                                                                               | -                                                       | -24 db /octave |



| Item                                        | Specification                           |                                                        |                |
|---------------------------------------------|-----------------------------------------|--------------------------------------------------------|----------------|
| Random Vibration (Nonoperating and Storage) | <b>Spectral Break Point Frequencies</b> | <b>Acceleration Spectral Density</b>                   | <b>Slope</b>   |
|                                             | 2.5 – 5 Hz                              | -                                                      | 6 db /octave   |
|                                             | 5 – 100 Hz                              | 1.0 [(m/s <sup>2</sup> )/Hz* (0.01 g <sup>2</sup> /Hz) | -              |
|                                             | 100 – 200 Hz                            | -                                                      | -24 db /octave |

<sup>4</sup> Minimum ambient temperature for cold startup is 0°C

<sup>5</sup> Short-term exceptional conditions are for no longer than a one-year period of—96 consecutive hours, or 360 hours total, or 15 occurrences.

## Power Supply Specifications

### 2000W AC-Input Power Supply Specifications

The following table lists specifications for the 2000W AC input power supply:

**Table 10: 2000W AC-Input Power Supply Specifications**

| Specification      | Description                                                                                                                                                                                                                                                                                     |
|--------------------|-------------------------------------------------------------------------------------------------------------------------------------------------------------------------------------------------------------------------------------------------------------------------------------------------|
| AC-input type      | Wide-ranging input with power factor correction.<br><b>Note</b> Power factor correction is a standard feature on AC-input power supplies. Power factor correction reduces the reactive component in the source AC current, allowing higher power factors and lower harmonic current components. |
| AC-input voltage   | Low-line (115 VAC nominal)—90VAC (min) to 140VAC (max)<br>High-line (230 VAC nominal)—180VAC (min) to 264VAC (max)                                                                                                                                                                              |
| AC-input current   | 10.5A at 115VAC (1050W output)<br>7.8A at 230 VAC (2000W output)                                                                                                                                                                                                                                |
| AC-input frequency | 50/60Hz nominal (47 to 63Hz full range)                                                                                                                                                                                                                                                         |

| Specification                                     | Description                                                                                                                                                                                                                                                                                                                                                                                                                                                                                                                                                                                                                                                                                                                                                                                                                        |
|---------------------------------------------------|------------------------------------------------------------------------------------------------------------------------------------------------------------------------------------------------------------------------------------------------------------------------------------------------------------------------------------------------------------------------------------------------------------------------------------------------------------------------------------------------------------------------------------------------------------------------------------------------------------------------------------------------------------------------------------------------------------------------------------------------------------------------------------------------------------------------------------|
| Branch circuit requirement                        | <p>Each chassis power supply should have its own dedicated, fused-branch circuit:</p> <ul style="list-style-type: none"> <li>• North America—15 A.</li> <li>• International—Circuits sized to local and national codes.</li> <li>• All AC power supply inputs are fully isolated. <ul style="list-style-type: none"> <li>• Source AC can be out of phase between multiple power supplies in the same chassis, which means that PS1 can be operating from phase A and PS2 can be operating from phase B.</li> <li>• For high-line operation, the power supply operates with the line conductor wired to a source AC phase, and the Neutral conductor wired either to a Neutral, single-phase power system, or to another source AC phase as long as the net input voltage is in the range of 180 to 264 VAC.</li> </ul> </li> </ul> |
| Power supply output                               | <ul style="list-style-type: none"> <li>• 100 to 120 VAC operation <ul style="list-style-type: none"> <li>• 12V output — 1050W</li> </ul> </li> <li>• 200 to 240 VAC operation <ul style="list-style-type: none"> <li>• 12V output — 2000W</li> </ul> </li> </ul>                                                                                                                                                                                                                                                                                                                                                                                                                                                                                                                                                                   |
| Output holdup time                                | 20 ms minimum with 1200W output                                                                                                                                                                                                                                                                                                                                                                                                                                                                                                                                                                                                                                                                                                                                                                                                    |
| kVA rating <sup>6</sup>                           | 2250W maximum (total output power)                                                                                                                                                                                                                                                                                                                                                                                                                                                                                                                                                                                                                                                                                                                                                                                                 |
| Heat dissipation (in British Thermal Units (BTU)) | 683 BTU per hour                                                                                                                                                                                                                                                                                                                                                                                                                                                                                                                                                                                                                                                                                                                                                                                                                   |
| Weight                                            | 2.65 lb (1.2 kg)                                                                                                                                                                                                                                                                                                                                                                                                                                                                                                                                                                                                                                                                                                                                                                                                                   |

<sup>6</sup> The kVA rating listed for the power supply should be used as the sizing criteria for both UPS outputs as well as standard circuits and transformers to power a switch

## 2000WAC Power Supply AC Power Cords

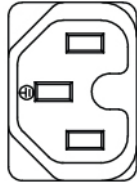
The following table lists the specifications for the AC power cords that are available for the 2000W AC-input power supply. The table also includes references to power cord illustrations.



**Note** All 2000W power supply power cord:

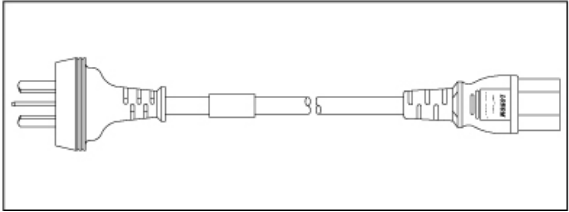
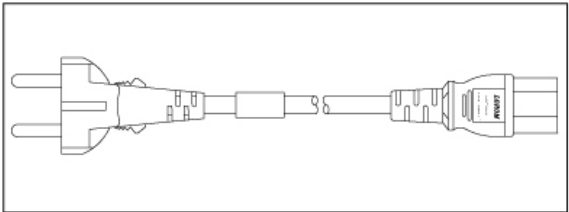
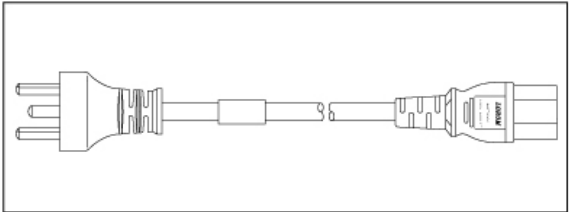
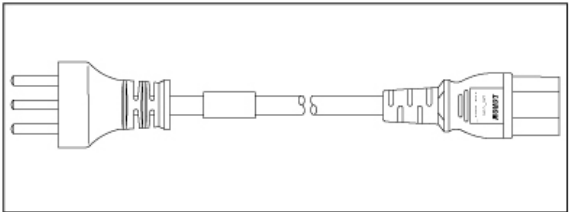
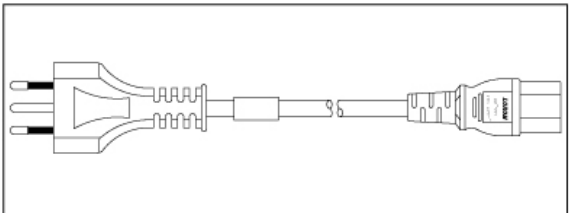
- Lengths range from 9.84 – 14 feet (3.0 – 4.293 meters); with most cord lengths between 13 and 14 feet (4.013 and 4.293 meters)
- Have an IEC60320/C15 appliance connector at one end.



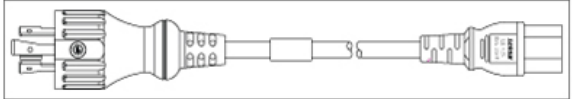
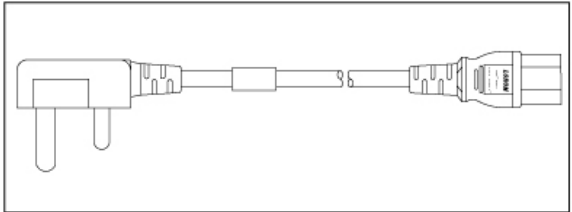
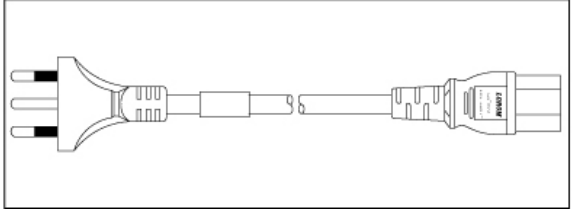
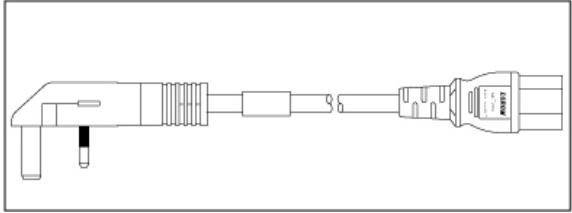
**Figure 53: IEC60320/C15 Appliance Connector**

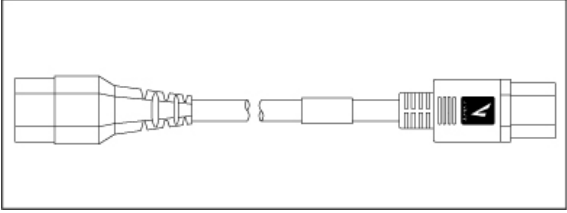


**Table 11: 2000 W Power Supply AC Power Cords**

| Locale        | Part Number  | Cordset Rating | Length        | AC Source Plug Type                                 |
|---------------|--------------|----------------|---------------|-----------------------------------------------------|
| Brazil        | CAB-ACBZ-12A | 125 VAC, 12 A  | 2.5 meter (m) | <p><b>Figure 54: CAB-ACBZ-12A= (Brazil)</b></p>     |
| Japan         | CAB-TA-JP    | 125 VAC, 12 A  | 2.5 m         | <p><b>Figure 55: CAB-TA-JP= (Japan)</b></p>         |
| North America | CAB-TA-NA    | 125 VAC, 12 A  | 2.5 m         | <p><b>Figure 56: CAB-TA-NA= (North America)</b></p> |

| Locale             | Part Number | Cordset Rating | Length | AC Source Plug Type                                                                                                                         |
|--------------------|-------------|----------------|--------|---------------------------------------------------------------------------------------------------------------------------------------------|
| China              | CAB-TA-CN   | 250 VAC, 10 A  | 2.5 m  | <p><b>Figure 57: CAB-TA-CN= (China)</b></p>               |
| Continental Europe | CAB-TA-EU   | 250 VAC, 10 A  | 2.5 m  | <p><b>Figure 58: CAB-TA-EU= (Continental Europe)</b></p>  |
| Denmark            | CAB-TA-DN   | 250 VAC, 10 A  | 2.5 m  | <p><b>Figure 59: CAB-TA-DN= (Denmark)</b></p>            |
| Israel             | CAB-TA-IS   | 250 VAC, 16 A  | 2.5 m  | <p><b>Figure 60: CAB-TA-IS= (Israel)</b></p>            |
| Italy              | CAB-TA-IT   | 250 VAC, 10 A  | 2.5 m  | <p><b>Figure 61: CAB-TA-IT= (Italy)</b></p>             |

| Locale         | Part Number    | Cordset Rating | Length | AC Source Plug Type                                                                                                                                      |
|----------------|----------------|----------------|--------|----------------------------------------------------------------------------------------------------------------------------------------------------------|
| Japan          | CAB-C15-CBN-JP | 250 VAC, 12 A  | 3.05 m | <p><i>Figure 62: CAB-C15-CBN-JP=(Japan)</i></p>  <p>356290</p>         |
| Japan          | CAB-TA-250V-JP | 250 VAC, 15 A  | 2.5 m  | <p><i>Figure 63: CAB-TA-250V-JP=(Japan)</i></p>  <p>356044</p>         |
| North America  | CAB-AC-2KW-CBL | 250 VAC, 13 A  | 4.25 m | <p><i>Figure 64: CAB-AC-2KW-CBL=(North America)</i></p>  <p>356043</p> |
| India          | CAB-TA-IN      | 250 VAC, 10 A  | 2.5 m  | <p><i>Figure 65: CAB-TA-IN=(India)</i></p>  <p>356044</p>             |
| Switzerland    | CAB-TA-SW      | 250 VAC, 10 A  | 2.5 m  | <p><i>Figure 66: CAB-TA-SW=(Switzerland)</i></p>  <p>356050</p>      |
| United Kingdom | CAB-TA-UK      | 250 VAC, 10 A  | 2.5 m  | <p><i>Figure 67: CAB-TA-UK=(United Kingdom)</i></p>  <p>356051</p>   |

| Locale                     | Part Number | Cordset Rating | Length | AC Source Plug Type                                                                                                      |
|----------------------------|-------------|----------------|--------|--------------------------------------------------------------------------------------------------------------------------|
| All countries except Japan | CAB-C15-CBN | 250 VAC, 13 A  | 1.22 m | <p><i>Figure 68: CAB-C15-CBN=</i></p>  |

## 2000W DC-Input Power Supply Specifications

The following table lists specifications for the 2000W DC input power supply:

**Table 12: 2000W DC-Input Power Supply Specifications**

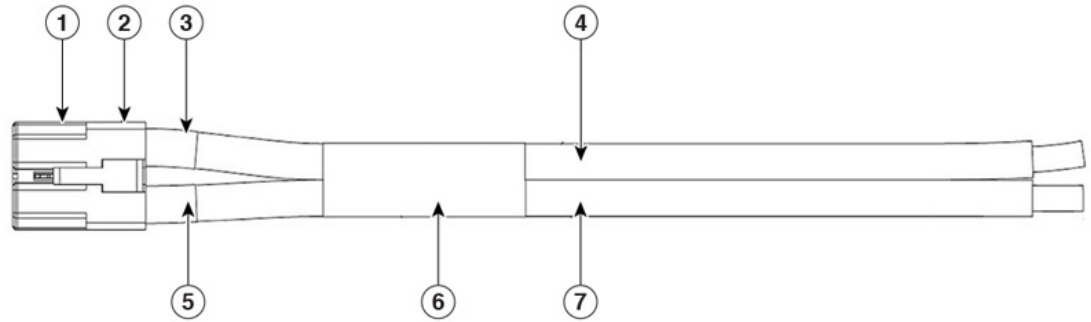
| Specification                                     | Description                                                                                                                                                                                                                                                                                                                                                                                              |
|---------------------------------------------------|----------------------------------------------------------------------------------------------------------------------------------------------------------------------------------------------------------------------------------------------------------------------------------------------------------------------------------------------------------------------------------------------------------|
| DC-input voltage                                  | -40 to -72VDC, with extended range to -75VDC                                                                                                                                                                                                                                                                                                                                                             |
| DC-input current                                  | Maximum: 60A per DC input at -40VDC input                                                                                                                                                                                                                                                                                                                                                                |
| Power supply output capacity                      | For 12VDC output—2000W                                                                                                                                                                                                                                                                                                                                                                                   |
| Output holdup time                                | 5ms with 1200W output                                                                                                                                                                                                                                                                                                                                                                                    |
| Temperature                                       | <ul style="list-style-type: none"> <li>Steady State Operating: -5°C to 45°C</li> <li>Non-operating: -40°C to +70°C</li> </ul>                                                                                                                                                                                                                                                                            |
| Humidity                                          | <ul style="list-style-type: none"> <li>Operating: 5 to 90 percent, non-condensing</li> <li>Non-operating: 5 to 95 percent, non-condensing</li> </ul>                                                                                                                                                                                                                                                     |
| Altitude                                          | <ul style="list-style-type: none"> <li>Operating: -500 to 10,000 feet over allowable temperature range (-5 to +45°C) and full load, de-rating 1.4°C per 1000 feet above 6,000 feet</li> </ul> <p><b>Note</b> The operating altitude in China is 6,561.6 ft. (2000 m) maximum</p> <ul style="list-style-type: none"> <li>Non-operating: -1,000 to 50,000 feet over allowable temperature range</li> </ul> |
| Heat dissipation (in British Thermal Units (BTU)) | 932 BTU per hour (maximum)                                                                                                                                                                                                                                                                                                                                                                               |
| Weight                                            | 2.82 lb (1.28 kg)                                                                                                                                                                                                                                                                                                                                                                                        |

### 2000W DC Power Supply DC Power Cords

All 2000W DC power supply cords:

- Lengths range from 9.84 to 14 feet (3.0 to 4.293 meters); with most cord lengths between 13 and 14 feet (4.013 and 4.293 meters)

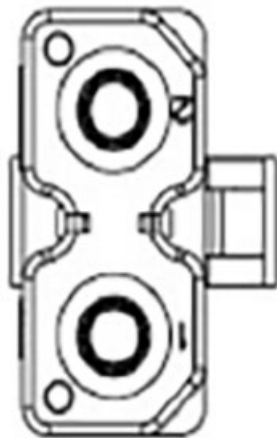
**Figure 69: 2000W DC Power Supply Cord**



|   |                                                       |   |                                                     |
|---|-------------------------------------------------------|---|-----------------------------------------------------|
| 1 | Appliance connector (C10-638974-000)                  | 5 | 6 AWG ultra flex cable or equivalent (red in color) |
| 2 | Plug housing (C10-638978)                             | 6 | Label                                               |
| 3 | Socket contact                                        | 7 | 2x shrink wrap                                      |
| 4 | 6 AWG ultra flex cable or equivalent (black in color) | - | -                                                   |

- Have an C10-638974-000 appliance connector at one end.

**Figure 70: C10-638974-000 Appliance Connector**



## 3000W AC-Input Power Supply Specifications

The following table lists specifications for the 3000W AC input power supply:

**Table 13: 3000W AC-Input Power Supply Specifications**

| Specification              | Description                                                                                                                                                                                                                                                                                                                                                                                                                                                                                                                                                                                                                                                                                                                                                                                                                 |
|----------------------------|-----------------------------------------------------------------------------------------------------------------------------------------------------------------------------------------------------------------------------------------------------------------------------------------------------------------------------------------------------------------------------------------------------------------------------------------------------------------------------------------------------------------------------------------------------------------------------------------------------------------------------------------------------------------------------------------------------------------------------------------------------------------------------------------------------------------------------|
| AC-input type              | Wide-ranging input with power factor correction.<br><br><b>Note</b> Power factor correction is a standard feature on AC-input power supplies. Power factor correction reduces the reactive component in the source AC current, allowing higher power factors and lower harmonic current components.                                                                                                                                                                                                                                                                                                                                                                                                                                                                                                                         |
| AC-input voltage           | Low-line (115 VAC nominal)—90VAC (min) to 140VAC (max)<br>High-line (230 VAC nominal)—180VAC (min) to 264VAC (max)                                                                                                                                                                                                                                                                                                                                                                                                                                                                                                                                                                                                                                                                                                          |
| AC-input current           | 17.6A at 100VAC (1500W output)<br>17.6A at 200 VAC (3000W output)                                                                                                                                                                                                                                                                                                                                                                                                                                                                                                                                                                                                                                                                                                                                                           |
| AC-input frequency         | 50/60Hz nominal (47 to 63Hz full range)                                                                                                                                                                                                                                                                                                                                                                                                                                                                                                                                                                                                                                                                                                                                                                                     |
| Branch circuit requirement | Each chassis power supply should have its own dedicated, fused-branch circuit: <ul style="list-style-type: none"> <li>• North America—20 A.</li> <li>• International—Circuits sized to local and national codes.</li> <li>• All AC power supply inputs are fully isolated. <ul style="list-style-type: none"> <li>• Source AC can be out of phase between multiple power supplies in the same chassis, which means that PS1 can be operating from phase A and PS2 can be operating from phase B.</li> <li>• For high-line operation, the power supply operates with the line conductor wired to a source AC phase, and the Neutral conductor wired either to a Neutral, single-phase power system, or to another source AC phase as long as the net input voltage is in the range of 180 to 264 VAC.</li> </ul> </li> </ul> |
| Power supply output        | <ul style="list-style-type: none"> <li>• 90 to 140 VAC operation <ul style="list-style-type: none"> <li>• 12V output—1500W</li> </ul> </li> <li>• 180 to 264 VAC operation <ul style="list-style-type: none"> <li>• 12V output—3000W</li> </ul> </li> </ul>                                                                                                                                                                                                                                                                                                                                                                                                                                                                                                                                                                 |
| Output holdup time         | 20 ms minimum with 1800W output at high line input                                                                                                                                                                                                                                                                                                                                                                                                                                                                                                                                                                                                                                                                                                                                                                          |
| kVA rating <sup>7</sup>    | 3000W maximum (total output power)                                                                                                                                                                                                                                                                                                                                                                                                                                                                                                                                                                                                                                                                                                                                                                                          |



| Specification                                     | Description       |
|---------------------------------------------------|-------------------|
| Heat dissipation (in British Thermal Units (BTU)) | 683 BTU per hour  |
| Weight                                            | 2.98 lb (1.35 kg) |

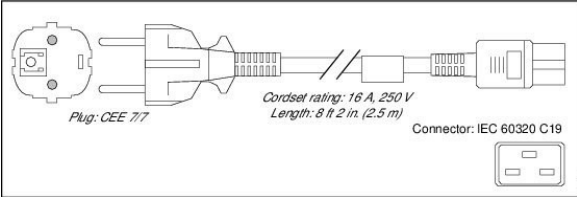
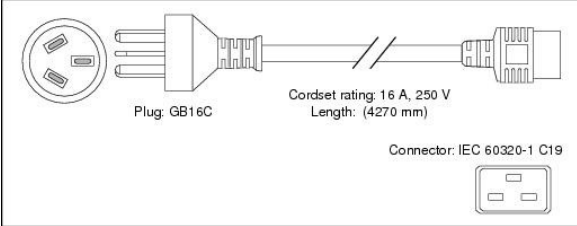
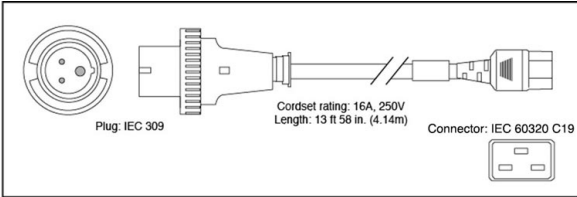
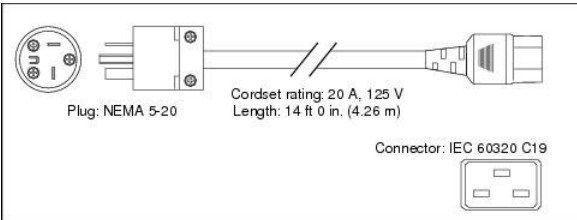
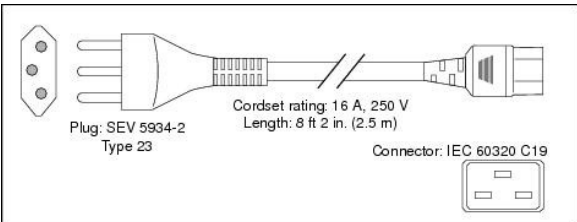
<sup>7</sup> The kVA rating listed for the power supply should be used as the sizing criteria for both UPS outputs as well as standard circuits and transformers to power a switch

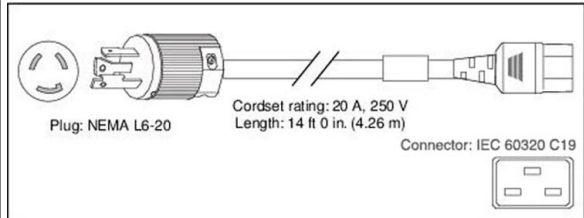
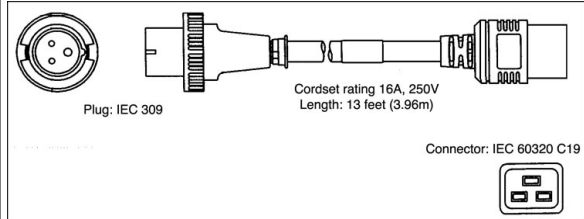
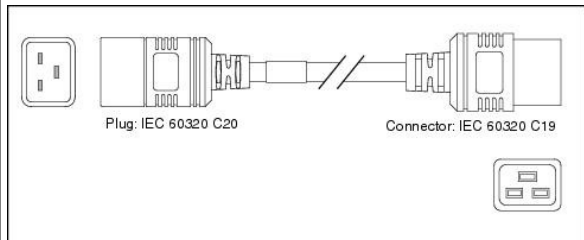
## 3000W AC Power Supply AC Power Cords

The following table lists the specifications for the AC power cords that are available for the 3000W AC-input power supply. The table also includes references to power cord illustrations.

Table 14: 3000 W Power Supply AC Power Cords

| Locale    | Part Number   | Cordset Rating | Length | AC Source Plug Type                                                                                                                                                         |
|-----------|---------------|----------------|--------|-----------------------------------------------------------------------------------------------------------------------------------------------------------------------------|
| Australia | CAB-9K16A-AUS | 250 VAC, 16 A  | 4.26 m | <p><b>Figure 71: CAB-9K16A-AUS= (Australia)</b></p> <p>Plug: AU20S3</p> <p>Cordset rating: 16 A, 250 V<br/>Length: 14 ft 0 in. (4.26 m)</p> <p>Connector: IEC 60320 C19</p> |

| Locale                  | Part Number   | Cordset Rating | Length | AC Source Plug Type                                                                                                                                                                                                                                                        |
|-------------------------|---------------|----------------|--------|----------------------------------------------------------------------------------------------------------------------------------------------------------------------------------------------------------------------------------------------------------------------------|
| Continental Europe      | CAB-9K16A-EU  | 250 VAC, 16 A  | 2.5 m  | <p><b>Figure 72: CAB-9K16A-EU= (Continental Europe)</b></p>  <p>Plug: CEE 7/7<br/>Cordset rating: 16 A, 250 V<br/>Length: 8 ft 2 in. (2.5 m)<br/>Connector: IEC 60320 C19</p>            |
| China                   | CAB-9k16A-CH  | 250 VAC, 16 A  | 4.27 m | <p><b>Figure 73: CAB-9k16A-CH= (China)</b></p>  <p>Plug: GB16C<br/>Cordset rating: 16 A, 250 V<br/>Length: (4270 mm)<br/>Connector: IEC 60320-1 C19</p>                                  |
| International           | CAB-9K16A-INT | 250 VAC, 16 A  | 4.14 m | <p><b>Figure 74: CAB-9K16A-INT= (International)</b></p>  <p>Plug: IEC 309<br/>Cordset rating: 16 A, 250 V<br/>Length: 13 ft 5 1/2 in. (4.14 m)<br/>Connector: IEC 60320 C19</p>         |
| North America and Japan | CAB-9K20A-NA  | 125 VAC, 20 A, | 4.26 m | <p><b>Figure 75: CAB-9K20A-NA= (North America and Japan)</b></p>  <p>Plug: NEMA 5-20<br/>Cordset rating: 20 A, 125 V<br/>Length: 14 ft 0 in. (4.26 m)<br/>Connector: IEC 60320 C19</p> |
| Switzerland             | CAB-9K16A-SW  | 250 VAC, 16 A  | 2.5 m  | <p><b>Figure 76: CAB-9K16A-SW= (Switzerland)</b></p>  <p>Plug: SEV 5934-2<br/>Type 23<br/>Cordset rating: 16 A, 250 V<br/>Length: 8 ft 2 in. (2.5 m)<br/>Connector: IEC 60320 C19</p>  |

| Locale                    | Part Number       | Cordset Rating | Length | AC Source Plug Type                                                                                                                                                                                                                                         |
|---------------------------|-------------------|----------------|--------|-------------------------------------------------------------------------------------------------------------------------------------------------------------------------------------------------------------------------------------------------------------|
| US and Japan              | CAB-9K16A-US2     | 250 VAC, 16 A  | 4.26 m | <p><b>Figure 77: CAB-9K16A-US2= (US/Japan)</b></p>  <p>Plug: NEMA L6-20<br/>Cordset rating: 20 A, 250 V<br/>Length: 14 ft 0 in. (4.26 m)<br/>Connector: IEC 60320 C19</p> |
| International             | CAB-I309-C19-INTL | 250 VAC, 16 A  | 3.96 m | <p><b>Figure 78: CAB-I309-C19-INTL= (International)</b></p>  <p>Plug: IEC 309<br/>Cordset rating 16A, 250V<br/>Length: 13 feet (3.96m)<br/>Connector: IEC 60320 C19</p>   |
| Cabinet Jumper Power Cord | CAB-C19-CBN       | 250 VAC, 16 A  | 2.74 m | <p><b>Figure 79: CAB-C19-CBN=(Cabinet Jumper Power Cord)</b></p>  <p>Plug: IEC 60320 C20<br/>Connector: IEC 60320 C19</p>                                                |

## Chassis and Module Power and Heat Values

The following tables provide the power and heat dissipation data. Unless otherwise noted, the information in the tables is measured under fully loaded conditions (transceivers installed).



**Note** DC output power is the output from the power supply (internal to the system). The AC-input power is the input from the outlet to the power supply. The percentage difference between the two values is the efficiency of the power supply.

Table 15: Power Requirements and Heat Dissipation - Fan Tray

| PID       | AC-Input Power in Watts<br>(Power Allocated) | DC-Output in Watts<br>(Power Requested) | Current @ 90V | Current @ 120V | Current @ 180V | Current @ 240V | Heat Diss. in BTU / hr. |
|-----------|----------------------------------------------|-----------------------------------------|---------------|----------------|----------------|----------------|-------------------------|
| C9606-FAN | 500                                          | 450                                     | 5.6           | 4.2            | 2.8            | 2.1            | 1706                    |

Table 16: Power Requirements and Heat Dissipation - Supervisor Module

| PID          | AC-Input Power in Watts<br>(Power Allocated) | DC-Output in Watts<br>(Power Requested) | Current @ 90V | Current @ 120V | Current @ 180V | Current @ 240V | Heat Diss. in BTU / hr. |
|--------------|----------------------------------------------|-----------------------------------------|---------------|----------------|----------------|----------------|-------------------------|
| C9600-SUP-1  | 862                                          | 775                                     | 9.6           | 7.2            | 4.8            | 3.6            | 2942                    |
| C9600X-SUP-2 | 732                                          | 660W                                    | 8.15          | 6.1            | 4.1            | 3.05           | 2498                    |

Table 17: Power Requirements and Heat Dissipation— Line Cards

| PID              | AC-Input Power in Watts<br>(Power Allocated) | DC-Output in Watts<br>(Power Requested) | Current @ 90V | Current @ 120V | Current @ 180V | Current @ 240V | Heat Diss. in BTU / hr. |
|------------------|----------------------------------------------|-----------------------------------------|---------------|----------------|----------------|----------------|-------------------------|
| C9600-LC-48S     | 256                                          | 230                                     | 2.9           | 2.2            | 1.5            | 1.1            | 874                     |
| C9600-LC-48YL    | 256                                          | 230                                     | 2.9           | 2.2            | 1.5            | 1.1            | 874                     |
| C9600-LC-24C     | 223                                          | 200                                     | 2.5           | 1.9            | 1.3            | 1              | 761                     |
| C9600-LC-48TX    | 350                                          | 315                                     | 3.9           | 3              | 2              | 1.5            | 1195                    |
| C9600-LC-40YL4CD | 466                                          | 420                                     | 5.2           | 3.9            | 2.6            | 1.95           | 1590                    |
| C9600X-LC-32CD   | 495                                          | 450                                     | 5.6           | 4.2            | 2.8            | 2.1            | 1689                    |
| C9600X-LC-56YL4C | 495                                          | 450                                     | 5.6           | 4.2            | 2.8            | 2.1            | 1689                    |

## Weight Specifications

The total weight of a fully configured chassis will depend on the type of chassis, the number of modules, and power supplies installed. Use the corresponding weights in the tables below to arrive at the total chassis weight for your hardware configuration.

**Weight Measurement for Chassis**

| <b>PID (add = for spare)</b> | <b>Weight (Chassis without Fan Tray and Power Supply Units)</b> |
|------------------------------|-----------------------------------------------------------------|
| C9606R                       | 55.90 lb (25.36 kg)                                             |

**Weight Measurements for Supervisor Module**

| <b>PID (add = for spare)</b> | <b>Weight</b>      |
|------------------------------|--------------------|
| C9600-SUP-1                  | 12.02 lb (5.45 kg) |
| C9600X-SUP-2                 | 12.02 lb (5.45 kg) |

**Weight Measurements for Line Cards**

| <b>PID (add = for spare)</b> | <b>Weight</b>      |
|------------------------------|--------------------|
| C9600-LC-48S                 | 7.83 lb (3.55 kg)  |
| C9600-LC-48YL                | 7.83 lb (3.55 kg)  |
| C9600-LC-24C                 | 7.67 lb (3.48 kg)  |
| C9600-LC-48TX                | 8.88 lb (4.03 kg)  |
| C9600-LC-40YL4CD             | 8.27 lb (3.75 kg)  |
| C9600X-LC-32CD               | 8.71 lb (3.95 kg)  |
| C9600X-LC-56YL4C             | 9.14 lbs (4.15 kg) |

**Weight Measurements for Power Supply Modules**

| <b>PID (add = for spare)</b> | <b>Weight</b>     |
|------------------------------|-------------------|
| C9600-PWR-2KWAC              | 2.65 lb (1.2 kg)  |
| C9600-PWR-2KWDC              | 2.82 lb (1.28 kg) |
| C9600-PWR-3KWAC              | 2.98 lb (1.35 kg) |

**Blank Covers**

| <b>PID (add = for spare)</b>                                                   | <b>Weight</b>    |
|--------------------------------------------------------------------------------|------------------|
| C9606-SLOT-BLANK<br>(Cisco Catalyst 9600 Series Blank for Chassis Module Slot) | 2.87 lb (1.3 kg) |

| <b>PID (add = for spare)</b>                                                        | <b>Weight</b>     |
|-------------------------------------------------------------------------------------|-------------------|
| C9606-PWR-BLANK<br>(Cisco Catalyst 9600 Series Blank for Chassis Power Supply Slot) | 0.18 lb (0.08 kg) |





# APPENDIX **B**

## LEDs

- Fan Tray LEDs, on page 113
- Power Supply Modules LEDs, on page 114
- Supervisor Module LEDs, on page 115
- Line Card LEDs, on page 116

## Fan Tray LEDs

*Table 18: Fan Tray LEDs*

| LED Type                                                                                      | LED Position or Color | Meaning                                                                                                                                                                                                                                                                                                                                                                                                             |
|-----------------------------------------------------------------------------------------------|-----------------------|---------------------------------------------------------------------------------------------------------------------------------------------------------------------------------------------------------------------------------------------------------------------------------------------------------------------------------------------------------------------------------------------------------------------|
| <br>STATUS | Off                   | Fan tray is not getting any power.                                                                                                                                                                                                                                                                                                                                                                                  |
|                                                                                               | Green                 | All fans are running and the fan tray is operating normally.                                                                                                                                                                                                                                                                                                                                                        |
|                                                                                               | Amber                 | One fan is not running.                                                                                                                                                                                                                                                                                                                                                                                             |
|                                                                                               | Red                   | Two or more fans are not running.                                                                                                                                                                                                                                                                                                                                                                                   |
| <br>LOCATE | Blue                  | <p>Identifies the fan tray receiving the beacon signal.</p> <p>The fan tray assembly has two blue beacon LEDs, one on the front panel and one on the rear. The two will always match each other.</p> <p>The blue beacon LED on the front panel is also a switch that you can press, to turn the front and rear blue beacons on or off. Alternatively, you can turn the blue beacons on or off through software.</p> |

## Power Supply Modules LEDs





*Table 19: Power Supply Module LEDs*

| LED Position or Colour | Meaning                                                                                                                                                                                                                                                                                                                                                        |
|------------------------|----------------------------------------------------------------------------------------------------------------------------------------------------------------------------------------------------------------------------------------------------------------------------------------------------------------------------------------------------------------|
| Solid Green            | Indicates that the power supply module is switched on with outputs 12V main and 12Vstandby available and in regulation.                                                                                                                                                                                                                                        |
| Solid Amber            | Indicates one of the following: <ul style="list-style-type: none"> <li>• No output power available</li> <li>• AC/DC input is below the operating range</li> <li>• No 12V standby from a parallel unit is available</li> <li>• Over voltage/over current/over temperature conditions</li> <li>• Over-temperature protection (OTP) due to fan failure</li> </ul> |
| 1Hz Blinking Amber     | Indicates warning events such as a power supply module that continues to operate in high temperature or high power and a fan that runs slow and so on.                                                                                                                                                                                                         |
| 2Hz Blinking Green     | Indicates that power switch is turned off with AC/DC input power available or that the power supply is in standby mode.                                                                                                                                                                                                                                        |
| 1Hz Blinking Green     | Indicates bootloading mode.                                                                                                                                                                                                                                                                                                                                    |
| Off                    | Indicates one of the following: <ul style="list-style-type: none"> <li>• No input or output power available</li> <li>• AC/DC input is below the operating range</li> <li>• No 12V standby from a parallel unit</li> </ul>                                                                                                                                      |





# Supervisor Module LEDs


Table 20: LEDs and the Status

| LED type                                                                                         | LED Position or Colour | Meaning                                                                                                                                                                                                               |
|--------------------------------------------------------------------------------------------------|------------------------|-----------------------------------------------------------------------------------------------------------------------------------------------------------------------------------------------------------------------|
| <br>STATUS      | Green                  | Indicates that all diagnostic tests have passed after image booting.                                                                                                                                                  |
|                                                                                                  | Amber                  | Indicates a major environmental warning.                                                                                                                                                                              |
|                                                                                                  | Red                    | Indicates a fault in the module due to parity error or failed diagnostic tests or hardware failure.                                                                                                                   |
|                                                                                                  | Off                    | Indicates that the supervisor module is disabled or is not powered up.                                                                                                                                                |
| <br>BLUE BEACON | Solid blue             | Identifies the supervisor module receiving the beacon signal.                                                                                                                                                         |
| <br>SYSTEM      | Green                  | Indicates that the environmental monitors are normal.                                                                                                                                                                 |
|                                                                                                  | Amber                  | Indicates a minor fault such as partial power supply or fan failure.                                                                                                                                                  |
|                                                                                                  | Red                    | Indicates a major fault. For example, situations where the temperature of the supervisor module exceeds the critical threshold.                                                                                       |
| <br>ACTIVE    | Green                  | Indicates that the supervisor module is operational and is functioning as the active supervisor (in redundant supervisor module configurations).                                                                      |
|                                                                                                  | Amber                  | Indicates one of the following: <ul style="list-style-type: none"> <li>• ROMMON mode</li> <li>• Supervisor module is functioning as the standby supervisor (in redundant supervisor module configurations)</li> </ul> |
|                                                                                                  | Blinking Amber         | Indicates Graceful Insertion and Removal (GIR) of the module.                                                                                                                                                         |

## Line Card LEDs

Table 21: Line Card LEDs

| LED Type                                                                                          | LED Position or Colour                                                                                                                                                                                                                                                                                                                                                                                                                                                                                                                                                   | Meaning                                                                                                                                                                                                   |
|---------------------------------------------------------------------------------------------------|--------------------------------------------------------------------------------------------------------------------------------------------------------------------------------------------------------------------------------------------------------------------------------------------------------------------------------------------------------------------------------------------------------------------------------------------------------------------------------------------------------------------------------------------------------------------------|-----------------------------------------------------------------------------------------------------------------------------------------------------------------------------------------------------------|
| <br>Blue Beacon  | Blue                                                                                                                                                                                                                                                                                                                                                                                                                                                                                                                                                                     | Indicates that the module requires attention. Provisioned by the administrator of the system.                                                                                                             |
|                                                                                                   | Off                                                                                                                                                                                                                                                                                                                                                                                                                                                                                                                                                                      | Indicates that the module does not need any attention.                                                                                                                                                    |
|                                                                                                   | Slow Blinking Blue                                                                                                                                                                                                                                                                                                                                                                                                                                                                                                                                                       | Indicates that the module requires attention. Configured by the user. The LED blinks at a rate of 1.2 seconds.                                                                                            |
|                                                                                                   | Fast Blinking Blue                                                                                                                                                                                                                                                                                                                                                                                                                                                                                                                                                       | Indicates that the module requires attention. The LED blinks at a rate of 0.6 seconds.                                                                                                                    |
|                                                                                                   | <p>From Cisco IOS XE Cupertino 17.9.x, the blue beacon LED on C9600X-LC-32CD and C9600-LC-40YL4CD can be configured to blink at slow, fast or steady (no blink) rates, which can be used to identify devices that need to be serviced. For example, if you have to make changes to the three Field Replaceable Units (FRU) in the system, you can configure the FRUs to use the beacon LED at three different blinking rates. This helps you to identify the FRU that is undergoing a change. Also, you can configure the beacon LED to use across multiple chassis.</p> |                                                                                                                                                                                                           |
| <br>Status LED | Off                                                                                                                                                                                                                                                                                                                                                                                                                                                                                                                                                                      | Indicates that the module is disabled or is not powered up.                                                                                                                                               |
|                                                                                                   | Green                                                                                                                                                                                                                                                                                                                                                                                                                                                                                                                                                                    | Indicates that all diagnostic tests have passed and the module is operational.<br><br><b>Note</b> From Cisco IOS XE Cupertino 17.9.x, the Status LED on C9600X-LC-32CD and C9600-LC-40YL4CD glows darker. |
|                                                                                                   | Red                                                                                                                                                                                                                                                                                                                                                                                                                                                                                                                                                                      | Indicates major environmental alarms, if the module is online.                                                                                                                                            |
|                                                                                                   | Amber                                                                                                                                                                                                                                                                                                                                                                                                                                                                                                                                                                    | Indicates minor environmental alarms, if the module is online.                                                                                                                                            |

| LED Type                                                                                      | LED Position or Colour      | Meaning                                                                          |                      |
|-----------------------------------------------------------------------------------------------|-----------------------------|----------------------------------------------------------------------------------|----------------------|
| <br>Port LED | Green                       | Port link is up.                                                                 |                      |
|                                                                                               | Amber                       | Port link is disabled, that is, administratively down.                           |                      |
|                                                                                               | Off                         | No signal is detected, the link is down, or the port is not connected.           |                      |
|                                                                                               | Alternating Green and Amber | Indicates port beacon.                                                           |                      |
|                                                                                               | Blinking Amber              | Indicates link faults such as excessive collision, CRC errors and Jabber errors. |                      |
|                                                                                               | Blinking green              | Indicates traffic on the port.                                                   |                      |
|                                                                                               |                             | <b>Traffic Utilization</b>                                                       | <b>Blinking Rate</b> |
|                                                                                               |                             | Less than 5%                                                                     | Nil                  |
| Between 5% and 30%                                                                            |                             | At a rate of 1.2 seconds.                                                        |                      |
| Between 30% and 70%                                                                           |                             | At a rate of 0.4 seconds.                                                        |                      |
| More than 70%                                                                                 | At a rate of 0.2 seconds.   |                                                                                  |                      |





## APPENDIX **C**

# Accessory Kit and Shelf Kit Contents

- [Standard Accessory Kit Contents, on page 119](#)
- [Shelf Kit Contents, on page 119](#)
- [23-Inch Rack Mount Kit Contents, on page 120](#)
- [23-Inch Rack Mount NEBS Kit Contents, on page 121](#)

## Standard Accessory Kit Contents

| Switch Model          | Standard Accessory Kit Part Number |
|-----------------------|------------------------------------|
| Catalyst 9606R Switch | C9606-ACC-KIT=                     |

Cisco Catalyst 9600 Series Switches ship with a standard accessory kit, which includes the following items:

| Item                                            | Quantity |
|-------------------------------------------------|----------|
| 12-24 x 0.75 inch M, Phillips screws            | 8        |
| 10-32 x 0.75 inch M, Phillips screws            | 8        |
| Adapter, DB9F/RJ45F                             | 1        |
| Grounding lug (no.10, with 2 holes), 6 AWG size | 1        |
| M4 x 8mm Phillips pan-head screws               | 2        |
| Fabricated plastic cable management guide       | 2        |

## Shelf Kit Contents



**Note** The shelf kit is not part of the standard accessory kit. You must order it separately by using the chassis-specific part number.

| Switch Model          | Shelf Kit Part Number |
|-----------------------|-----------------------|
| Catalyst 9606R Switch | C9606-SHELF-KIT=      |

The following table lists the contents of the shelf kit:

**Table 22: Shelf Kit Contents**

| Item and Description                                                                                  | Quantity |
|-------------------------------------------------------------------------------------------------------|----------|
| Left L bracket.<br>A fabricated metal chassis L bracket to secure the chassis to the rack enclosure.  | 1        |
| Right L bracket.<br>A fabricated metal chassis L bracket to secure the chassis to the rack enclosure. | 1        |
| Shelf brackets<br>Fabricated metal rack shelf brackets to support the weight of the chassis.          | 2        |
| Shelf crossbar<br>A fabricated metal rack shelf brackets crossbar to fix the shelf brackets.          | 1        |
| 12-24x0.75 In. Phillips screws                                                                        | 14       |
| 10-32x0.75 In. Phillips screws                                                                        | 14       |
| M4x5 mm Phillips flat head screws                                                                     | 10       |
| Documentation, pointer card<br>Provides references to related documentation on cisco.com              | 1        |

## 23-Inch Rack Mount Kit Contents



**Note** The 23-inch rack mount kit is not part of the standard accessory kit. You must order it separately by using the chassis-specific part number.

The 23-inch rack mount kit consists of the following items:

**Table 23: Contents of 23-Inch Rack Mount Kit**

| Parts Description                            | Quantity |
|----------------------------------------------|----------|
| Rack Mounts                                  | 2        |
| M4 Phillips pan-head screws                  | 6        |
| 12-24 x 3/4-inch Phillips binder-head screws | 6        |

## 23-Inch Rack Mount NEBS Kit Contents

| Switch Model          | 23-Inch Rack Mount NEBS Kit Part Number |
|-----------------------|-----------------------------------------|
| Catalyst 9606R Switch | C9606-FB-23-KIT=                        |

The 23-in. rack mount kit for NEBS installation consists of the following items:

**Table 24: Contents of 23 in. Rack Mount NEBS Kit**

| Parts Description                                                                           | Quantity |
|---------------------------------------------------------------------------------------------|----------|
| Top filter bracket<br>A fabricated metal bracket to attach the air filter.                  | 1        |
| Bottom filter bracket<br>A fabricated metal bracket to attach the air filter.               | 1        |
| Left ear bracket<br>A fabricated metal bracket to support the weight of the chassis.        | 1        |
| Left wall cover<br>A fabricated metal bracket to attach the left bracket and the chassis.   | 1        |
| Right ear bracket<br>A fabricated metal bracket to support the weight of the chassis.       | 1        |
| Air filter<br>The air filter for filtering dust particles from entering the chassis.        | 1        |
| Right wall cover<br>A fabricated metal bracket to attach the right bracket and the chassis. | 1        |
| Top cover<br>A fabricated metal box for guiding the airflow.                                | 1        |
| Base cover<br>A fabricated metal box for guiding the airflow.                               | 1        |
| M4x12 mm Phillips pan-head screws                                                           | 18       |
| M4x5 mm Phillips flat head screws                                                           | 18       |

| <b>Parts Description</b>          | <b>Quantity</b> |
|-----------------------------------|-----------------|
| M3x8 mm Phillips flat head screws | 6               |
| 12-24x0.75 in. Phillips screws    | 20              |
| 10-32x0.75 in. Phillips screws    | 20              |
| M3x6 mm Phillips pan-head screws  | 2               |



THE SPECIFICATIONS AND INFORMATION REGARDING THE PRODUCTS IN THIS MANUAL ARE SUBJECT TO CHANGE WITHOUT NOTICE. ALL STATEMENTS, INFORMATION, AND RECOMMENDATIONS IN THIS MANUAL ARE BELIEVED TO BE ACCURATE BUT ARE PRESENTED WITHOUT WARRANTY OF ANY KIND, EXPRESS OR IMPLIED. USERS MUST TAKE FULL RESPONSIBILITY FOR THEIR APPLICATION OF ANY PRODUCTS.

THE SOFTWARE LICENSE AND LIMITED WARRANTY FOR THE ACCOMPANYING PRODUCT ARE SET FORTH IN THE INFORMATION PACKET THAT SHIPPED WITH THE PRODUCT AND ARE INCORPORATED HEREIN BY THIS REFERENCE. IF YOU ARE UNABLE TO LOCATE THE SOFTWARE LICENSE OR LIMITED WARRANTY, CONTACT YOUR CISCO REPRESENTATIVE FOR A COPY.

The following information is for FCC compliance of Class A devices: This equipment has been tested and found to comply with the limits for a Class A digital device, pursuant to part 15 of the FCC rules. These limits are designed to provide reasonable protection against harmful interference when the equipment is operated in a commercial environment. This equipment generates, uses, and can radiate radio-frequency energy and, if not installed and used in accordance with the instruction manual, may cause harmful interference to radio communications. Operation of this equipment in a residential area is likely to cause harmful interference, in which case users will be required to correct the interference at their own expense.

The following information is for FCC compliance of Class B devices: This equipment has been tested and found to comply with the limits for a Class B digital device, pursuant to part 15 of the FCC rules. These limits are designed to provide reasonable protection against harmful interference in a residential installation. This equipment generates, uses and can radiate radio frequency energy and, if not installed and used in accordance with the instructions, may cause harmful interference to radio communications. However, there is no guarantee that interference will not occur in a particular installation. If the equipment causes interference to radio or television reception, which can be determined by turning the equipment off and on, users are encouraged to try to correct the interference by using one or more of the following measures:

- Reorient or relocate the receiving antenna.
- Increase the separation between the equipment and receiver.
- Connect the equipment into an outlet on a circuit different from that to which the receiver is connected.
- Consult the dealer or an experienced radio/TV technician for help.

Modifications to this product not authorized by Cisco could void the FCC approval and negate your authority to operate the product.

The Cisco implementation of TCP header compression is an adaptation of a program developed by the University of California, Berkeley (UCB) as part of UCB's public domain version of the UNIX operating system. All rights reserved. Copyright © 1981, Regents of the University of California.

NOTWITHSTANDING ANY OTHER WARRANTY HEREIN, ALL DOCUMENT FILES AND SOFTWARE OF THESE SUPPLIERS ARE PROVIDED "AS IS" WITH ALL FAULTS. CISCO AND THE ABOVE-NAMED SUPPLIERS DISCLAIM ALL WARRANTIES, EXPRESSED OR IMPLIED, INCLUDING, WITHOUT LIMITATION, THOSE OF MERCHANTABILITY, FITNESS FOR A PARTICULAR PURPOSE AND NONINFRINGEMENT OR ARISING FROM A COURSE OF DEALING, USAGE, OR TRADE PRACTICE.

IN NO EVENT SHALL CISCO OR ITS SUPPLIERS BE LIABLE FOR ANY INDIRECT, SPECIAL, CONSEQUENTIAL, OR INCIDENTAL DAMAGES, INCLUDING, WITHOUT LIMITATION, LOST PROFITS OR LOSS OR DAMAGE TO DATA ARISING OUT OF THE USE OR INABILITY TO USE THIS MANUAL, EVEN IF CISCO OR ITS SUPPLIERS HAVE BEEN ADVISED OF THE POSSIBILITY OF SUCH DAMAGES.

Any Internet Protocol (IP) addresses and phone numbers used in this document are not intended to be actual addresses and phone numbers. Any examples, command display output, network topology diagrams, and other figures included in the document are shown for illustrative purposes only. Any use of actual IP addresses or phone numbers in illustrative content is unintentional and coincidental.

All printed copies and duplicate soft copies of this document are considered uncontrolled. See the current online version for the latest version.

Cisco has more than 200 offices worldwide. Addresses and phone numbers are listed on the Cisco website at [www.cisco.com/go/offices](http://www.cisco.com/go/offices).

Cisco and the Cisco logo are trademarks or registered trademarks of Cisco and/or its affiliates in the U.S. and other countries. To view a list of Cisco trademarks, go to this URL: <https://www.cisco.com/c/en/us/about/legal/trademarks.html>. Third-party trademarks mentioned are the property of their respective owners. The use of the word partner does not imply a partnership relationship between Cisco and any other company. (1721R)

© 2019–2024 Cisco Systems, Inc. All rights reserved.

