



Installing a Power Supply

- [Power Supply Modules Overview, on page 1](#)
- [Installation Guidelines, on page 6](#)
- [Installing or Replacing an AC Power Supply, on page 7](#)
- [Installing a DC Power Supply, on page 8](#)
- [Finding the Power Supply Module Serial Number, on page 14](#)

Power Supply Modules Overview

The switch operates with either one or two active power supply modules. A switch that is part of a StackPower stack operates with power that is supplied by other stack switches. Two power supply modules can be powered up from two different phases.

You can use two AC modules or one module and blank cover. All power supply modules have internal fans. All switches ship with a blank cover in the second power supply slot.

The following table describes the supported internal power supply modules. It lists the Platinum certified power supply modules and the default modules that are shipped with the switch. In a switch, a mix of Platinum certified and non-Platinum certified power supply modules is supported.

Table 1: Power Supply Module Part Numbers and Descriptions

Switch Series	Supported Power Supply Modules	Description
C9300 Series Switches	PWR-C1-350WAC	350 W AC power supply module
	PWR-C1-715WAC	715 W AC power supply module
	PWR-C1-1100WAC	1100 W AC power supply module
	PWR-C1-715WAC-P	715 W AC Platinum certified power supply module
	PWR-C1-1100WAC-P	1100 W AC Platinum certified power supply module
	PWR-C1-1900WAC-P	1900 W AC Platinum certified power supply module
	PWR-C1-715WDC	715 W DC power supply module
	C9300L Series Switches	PWR-C1-350WAC
PWR-C1-715WAC	715 W AC power supply module	
PWR-C1-715WAC-P	715 W AC Platinum certified power supply module	
PWR-C1-1100WAC-P	1100 W AC Platinum certified power supply module	
PWR-C1-1900WAC-P	1900 W AC Platinum certified power supply module	
PWR-C1-715WDC	715 W DC power supply module	
C9300LM Series Switches	PWR-C6-600WAC	600 W AC Platinum certified power supply module
	PWR-C6-1KWAC	1000 W AC Platinum certified power supply module

Switch Series	Supported Power Supply Modules	Description
C9300X Series Switches	PWR-C1-350WAC-P	350 W AC Platinum certified power supply module
	PWR-C1-715WAC-P	715 W AC Platinum certified power supply module
	PWR-C1-715WDC	715 W DC power supply module
	PWR-C1-1100WAC-P	1100 W AC Platinum certified power supply module
	PWR-C1-1900WAC-P	1900 W AC Platinum certified power supply module



- Note** 1. PWR-C1-1900WAC-P provides 1900 W output power when the nominal input voltage is 230 V. If the nominal input voltage is 115 V, then the output power is limited to 1500 W. See [Table 2](#) for suitable power cord options.

For more information about power supplies, see [Specifications for the Power Supplies, Switches, and Fan](#).

For information on available PoE, PoE+, and Cisco UPOE/UPOE+ requirements, see these sections the [Power Supply Modules](#).

The 350 W and 715 W AC power supply modules are autoranging units that support input voltages from 100 through 240 VAC. The 1100W power supply module is an autoranging unit that supports input voltages from 115 through 240 VAC.

Each AC power supply module has a power cord for connection to an AC power outlet. To view the list of available AC power cords, see [AC Power Cord Specifications](#).

The following illustrations show the power supply modules.

Figure 1: 1100 W AC Power Supply

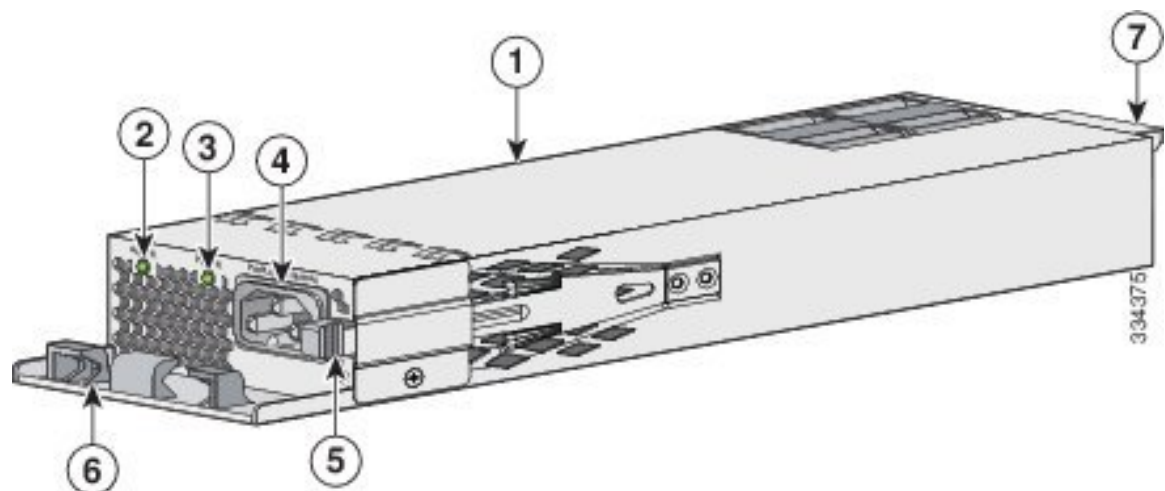

1	1100 W AC power supply module	5	Release latch
2	AC OK LED	6	Power cord retainer
3	PS OK LED	7	Keying feature
4	AC power cord connector	-	-

Figure 2: 1900 W AC Platinum Certified Power Supply

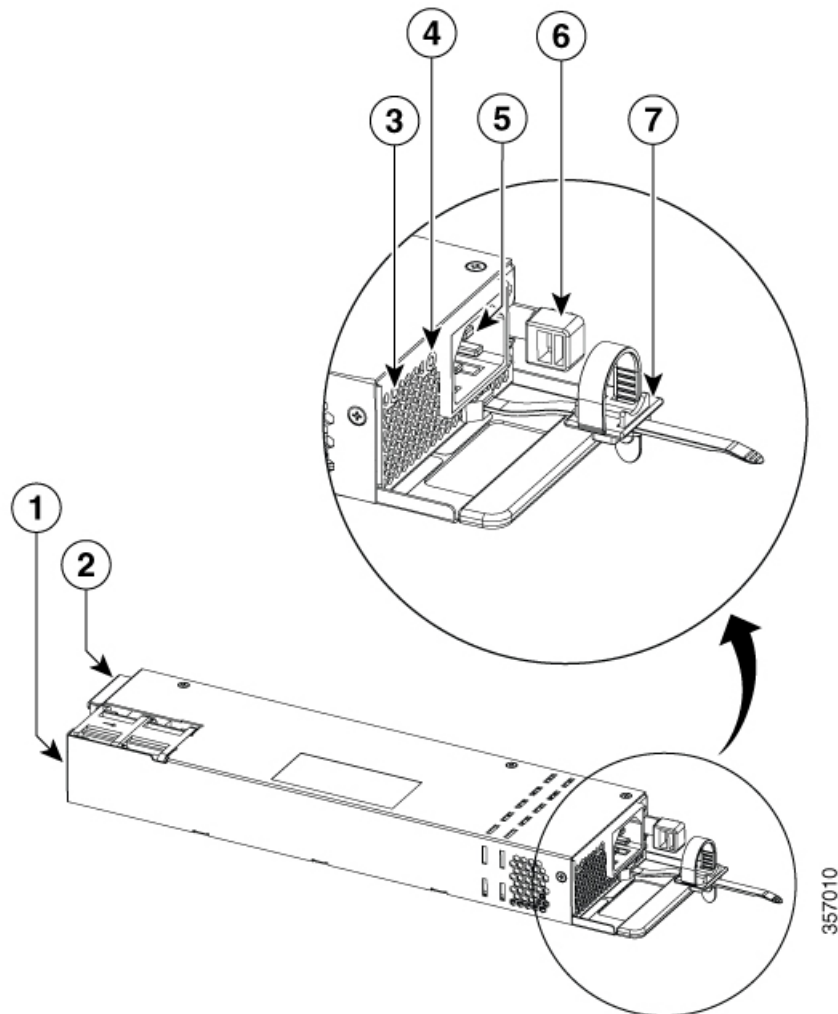

1	1900 W AC power supply module	5	AC power cord connector
2	Keying feature	6	Release latch
3	AC OK LED	7	Power cord retainer
4	PS OK LED		

Figure 3: 715W DC Power Supply (PWR-C1-715WDC)

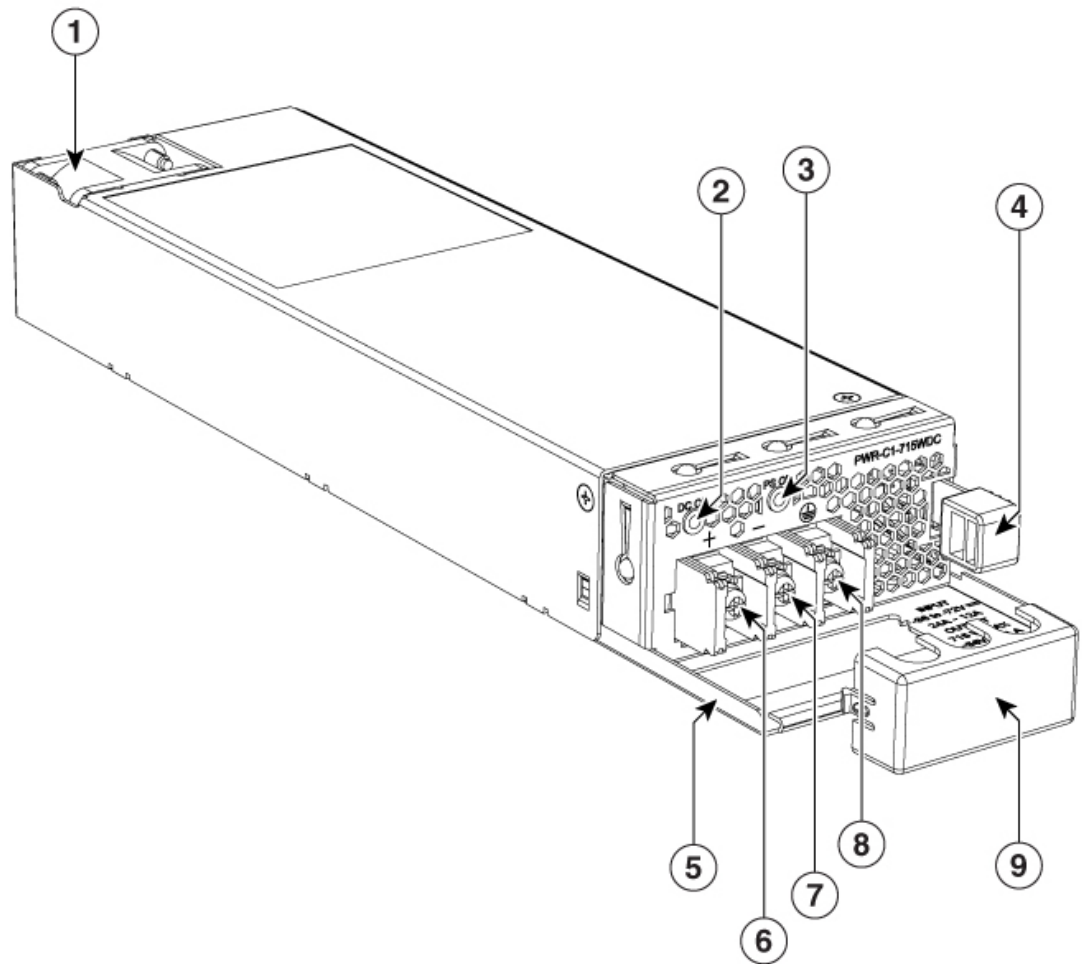

356179

1	715 W DC power supply module	6	Input power terminal (positive polarity)
2	DC OK LED	7	Input power terminal (negative polarity)
3	PS OK LED	8	Grounding terminal
4	Release latch	9	Terminal block safety cover
5	Extraction handle	-	-

If no power supply is installed in a power supply slot, install a power supply slot cover.

Figure 4: Power Supply Slot Cover

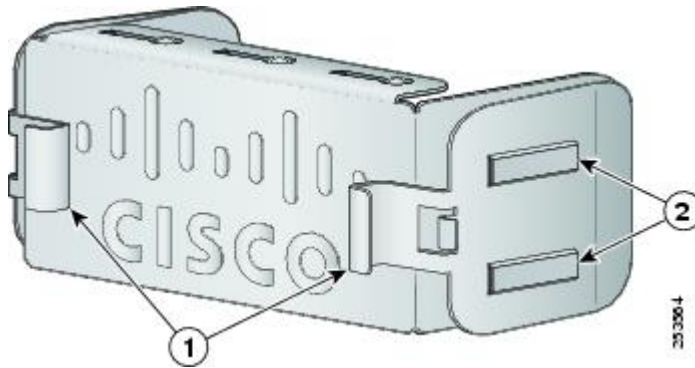

1	Release handles	2	Retainer clips
---	-----------------	---	----------------

Table 2: Switch Power Supply Module LEDs

AC or DC OK	Description	PS OK	Description
Off	No AC or DC input power.	Off	Output is disabled, or input is outside operating range (LED is off).
Green	AC or DC input power present.	Green	Power output to switch active.
		Red	Output has failed.

Installation Guidelines

Observe these guidelines when removing or installing a power supply or fan module:

- Do not force the power supply or fan module into the slot. This can damage the pins on the switch if they are not aligned with the module.
- A power supply that is only partially connected to the switch can disrupt the system operation.
- Remove power from the power-supply module before removing or installing the module.
- The power supply is hot-swappable. In some configurations, such as full PoE+ or power sharing mode, removing a power supply causes powered devices to shut down until the power budget matches the input power of a single power supply. To minimize network interruption, hot swap the power supply under these circumstances:
 - The switch is in StackPower mode and sufficient power is available.
 - The switch is powered by other switches in a power stack, and no active backup is in progress.

For the switch commands that display available power budget, see the software configuration guide.



Caution Do not operate the switch with one power-supply module slot empty. For proper chassis cooling, both module slots must be populated, with either a power supply or a blank module.

Take note of the following ground connection warnings:



Warning **Statement 1024**—Ground Conductor

This equipment must be grounded. To reduce the risk of electric shock, never defeat the ground conductor or operate the equipment in the absence of a suitably installed ground conductor. Contact the appropriate electrical inspection authority or an electrician if you are uncertain that suitable grounding is available.

Take note of the following general safety warnings:



Warning **Statement 1029**—Blank Faceplates and Cover Panels

Blank faceplates and cover panels serve three important functions: they reduce the risk of electric shock and fire, they contain electromagnetic interference (EMI) that might disrupt other equipment, and they direct the flow of cooling air through the chassis. Do not operate the system unless all cards, faceplates, front covers, and rear covers are in place.

Installing or Replacing an AC Power Supply

Procedure

- Step 1** Turn off the power at its source.
- Step 2** Remove the power cord from the power cord retainer.
- Step 3** Remove the power cord from the power connector.
- Step 4** Press the release latch at the right side of the power supply module inward and slide the power supply out.
- Caution** Do not leave the power-supply slot open for more than 90 seconds while the switch is operating.
- Warning** **Statement 1028**—More Than One Power Supply
- This unit might have more than one power supply connection. To reduce risk of electric shock, remove all connections to de-energize the unit.



- Step 5** Insert the new power supply into the power supply slot, and gently push it into the slot. When correctly inserted, the 350 W and 715 W power supplies (excluding the power cord retainer) are flush with the switch rear panel.

The 1100 W power supply modules extend 1.5 inches and 1900 W power supply modules extend 1.5 inches from the switch rear panel.

Figure 5: Inserting the AC Power Supply in the Switch

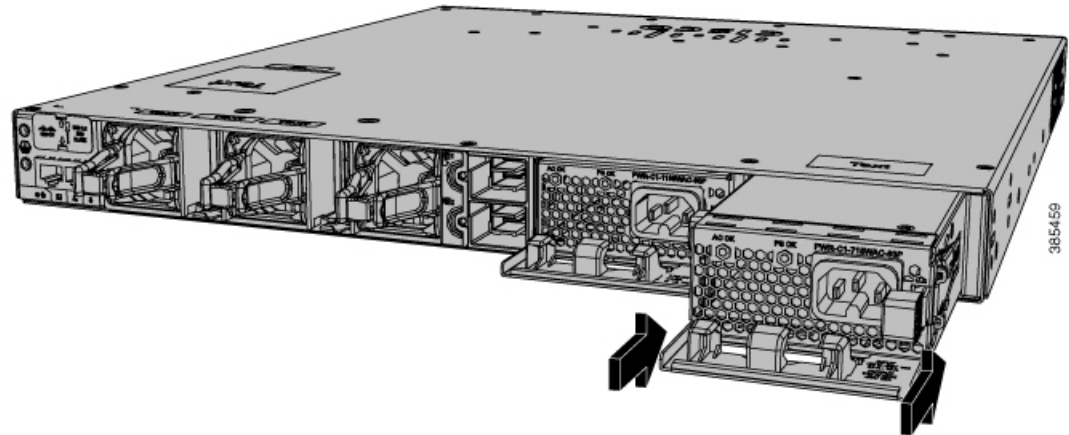

- Step 6** (Optional) Make a loop in the power cord and thread it through the power cord retainer or use the cable-tie retainer clip on the 1900 W supply.

Figure 6: AC-Power Supply with Power Cord Retainer

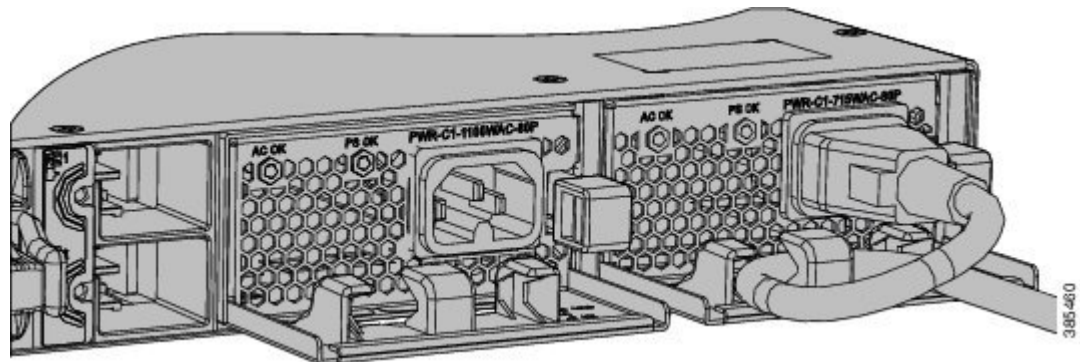

- Step 7** Connect the power cord to the power supply and to an AC power outlet. Turn on the power at the power source.
- Step 8** Confirm that the power supply AC OK and PS OK LEDs are green.

Installing a DC Power Supply

Take note of the following power safety warnings:

**Warning Statement 1003—DC Power Disconnection**

To reduce risk of electric shock or personal injury, disconnect DC power before removing or replacing components or performing upgrades.

**Warning Statement 1005—Circuit Breaker**

This product relies on the building's installation for short-circuit (overcurrent) protection. To reduce risk of electric shock or fire, ensure that the protective device is rated not greater than:

**Warning Statement 1022—Disconnect Device**

To reduce the risk of electric shock and fire, a readily accessible disconnect device must be incorporated in the fixed wiring.

**Warning Statement 1086—Replace Cover on Power Terminals**

Hazardous voltage or energy may be present on power terminals. To reduce the risk of electric shock, make sure the power terminal cover is in place when the power terminal is not being serviced. Be sure uninsulated conductors are not accessible when the cover is in place.



Note The grounding architecture of this product is DC-isolated (DC-I).

Equipment That You Need

- Ratcheting torque screwdriver with a number-2 Phillips head that exerts up to 15 pound-force inches (lbf-in.) of pressure.
- Panduit crimping tool with optional controlled-cycle mechanism (model CT-720, CT-920, CT-920CH, CT-930, or CT-940CH).
- Wire-stripping tools.
- 12-gauge copper ground wire (insulated or not) for the single-hole ground connection.
- 8-gauge copper ground wire (insulated or not) for the dual-hole ground connection.
- Dual-hole ground lug and two screws (included in the DC power supply accessory kit) and single-hole ground lug and screw (included in the switch accessory kit). The dual-hole lug is required for the grounding of the switch in NEBS installations where the DC supply is the only NEBS compliant power supply option.
- Four leads of 14-gauge copper wire.

- Four fork-type terminals from the DC power supply accessory kit. The terminals must be the proper size for M3 screws in a Dinkle DT-35-B25-style terminal block.
- M5 screws for 12 AWG wire connection for NEBS installations.

Grounding the Switch

Follow these steps to install either a single-hole ground lug or a dual-hole ground lug on the switch. Make sure to follow any grounding requirements at your site.

Before you begin

Take note of the following ground connection warnings:



Warning Statement 1024—Ground Conductor

This equipment must be grounded. To reduce the risk of electric shock, never defeat the ground conductor or operate the equipment in the absence of a suitably installed ground conductor. Contact the appropriate electrical inspection authority or an electrician if you are uncertain that suitable grounding is available.



Warning Statement 1046—Installing or Replacing the Unit

To reduce risk of electric shock, when installing or replacing the unit, the ground connection must always be made first and disconnected last.

If your unit has modules, secure them with the provided screws.



Caution Follow the grounding procedure instructions, and use a UL-listed lug (included in the accessory kit).



Caution To comply with the Telcordia GR-1089 NEBS standard for electromagnetic compatibility and safety, connect the (Management Ethernet) ports only to intra-building or unexposed wiring or cable. The intrabuilding cable must be shielded and the shield must be grounded at both ends. The intra-building port(s) of the equipment or subassembly must not be metallically connected to interfaces that connect to the OSP or its wiring. These interfaces are designed for use as intra-building interfaces only (Type 2 or Type 4 ports as described in GR-1089-CORE) and require isolation from the exposed OSP cabling. The addition of Primary Protectors is not sufficient protection in order to connect these interfaces metallically to OSP wiring.

Procedure

-
- Step 1** Use the ground lug screw and the lug ring for single-ground connections. Use the dual-hole lug for ground connections for NEBS installation.

- Step 2** Strip the 12-gauge or 8-gauge ground wire to 0.5 inch (12.7 mm) \pm 0.02 inch (0.5 mm). Stripping more than the recommended amount of wire can leave exposed wire from the connector. Use 12-gauge copper ground wire for the single-ground connection. Use 8-gauge copper ground wire for the dual-ground connection.

Figure 7: Stripping the Ground Wire

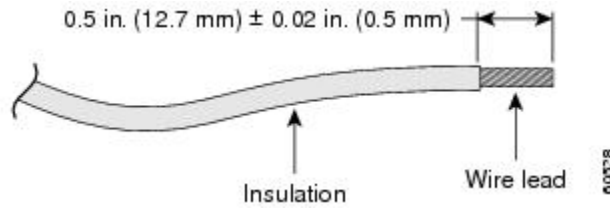

- Step 3** Slide the open end of the ground lug over the exposed area of the wire.

- Step 4** Using a Panduit crimping tool, crimp the ground lug to the wire.

Figure 8: Crimping the Ground Lug

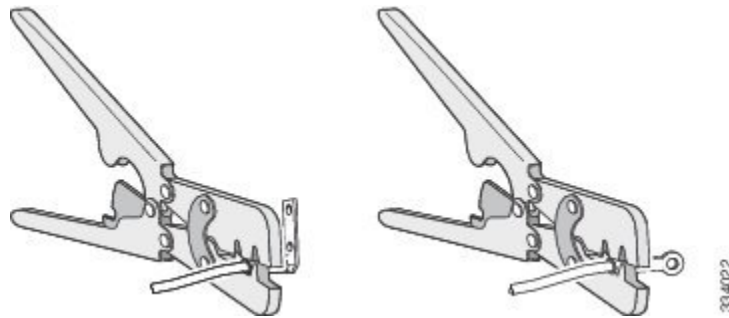

- Step 5** Use the ground screw to attach the single-hole ground lug to the switch rear panel. Use two ground screws to attach the dual-hole ground lug to the switch rear panel.

Figure 9: Attaching the Ground Lug and Wire Assembly

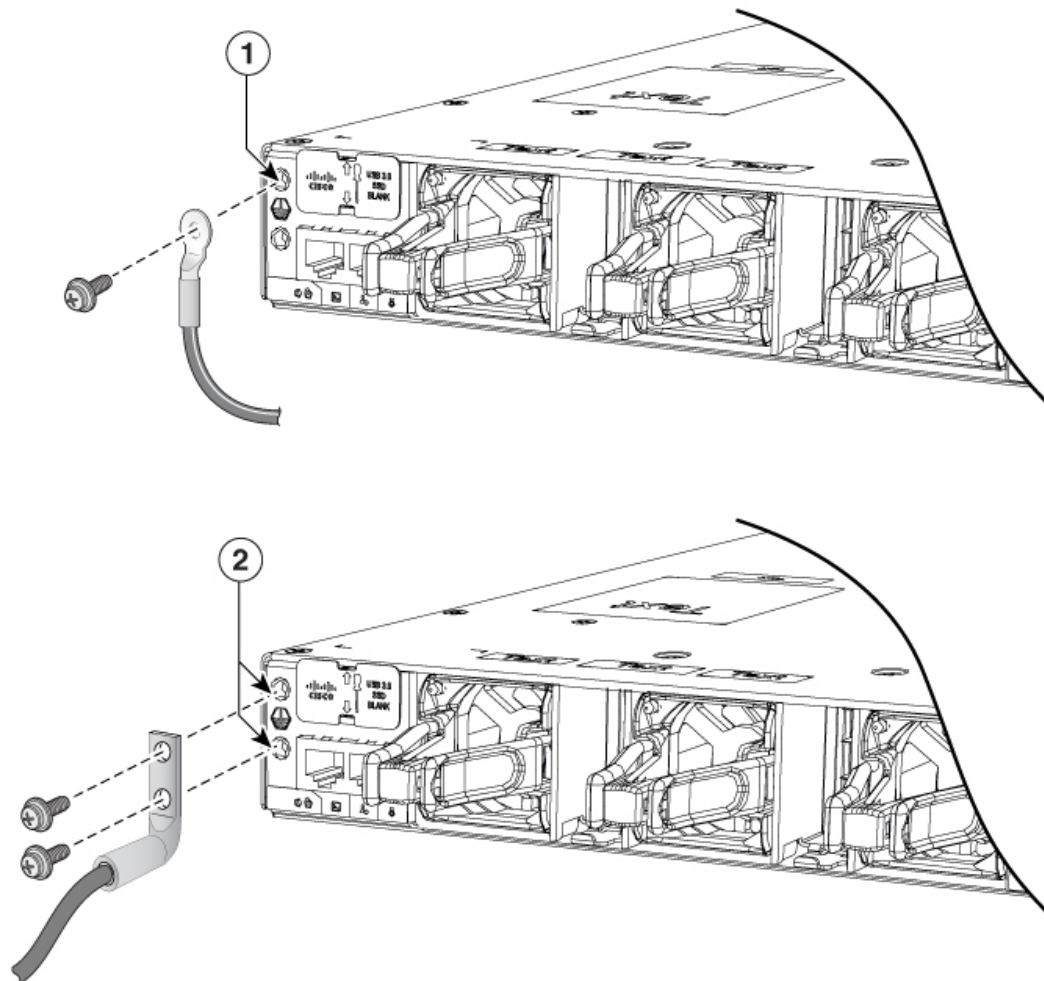

356234

1	Attaching the single-hole ground lug	2	Attaching the dual-hole ground lug
---	--------------------------------------	---	------------------------------------

Step 6 Using a ratcheting torque screwdriver, torque the ground-lug screws to 22-30 lbf-in.

Step 7 Connect the other end of the grounding wire to an appropriate grounding point at your site or to the rack.

Installing the DC Power Supply in the Switch

Before you begin

Before installing the power supply, see the [Installation Guidelines, on page 6](#).

Procedure

- Step 1** Verify that the power supply is not connected to any power sources.
- Step 2** Remove the plastic safety cover from the power supply terminal blocks.
- Note** If you are not replacing a DC power supply, go to Step 5.
- Step 3** Use a number-2 Phillips screwdriver to remove the DC-input power wires from the power terminals.
- Step 4** Press the release latch at the right side of the power supply module inward, and pull the power supply out.
- Step 5** Insert the power supply in the power-supply slot, and gently push it into the slot. When correctly installed, the DC power supply (excluding the extraction handle) is flush with the switch rear panel.

Figure 10: Inserting a DC-Power Supply

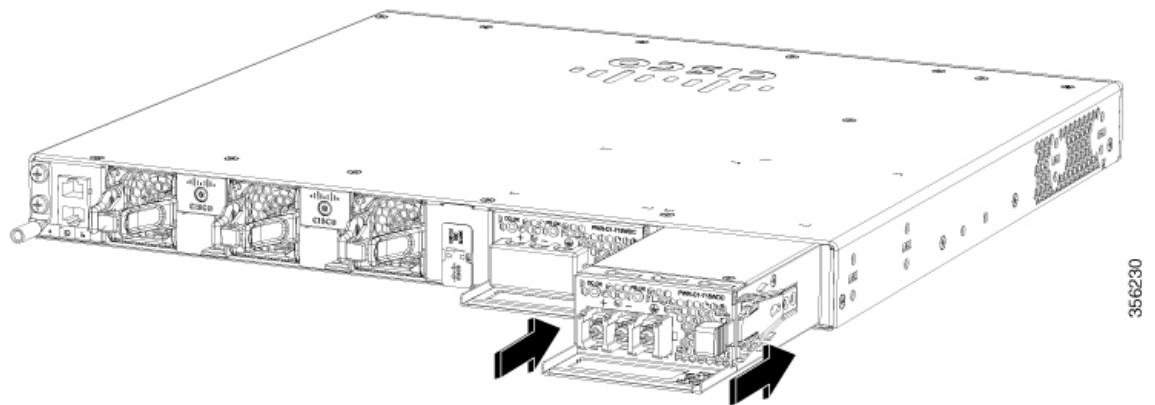

- Step 6** Connect the input power as described in [Wiring the DC Input Power Source](#), on page 13.
-

Wiring the DC Input Power Source

Procedure

- Step 1** Using a wire-stripping tool, strip the wires from the DC-input power source to the appropriate length for the terminals.
- Step 2** Using a Panduit crimping tool, crimp the fork-type terminals to the copper conductor, 90C, 12-AWG DC power input wires.
- Step 3** Connect the DC-input power terminals to the terminal blocks. Connect the ground wire to a grounded metal rack or to earth ground if the switch is not in a grounded rack.

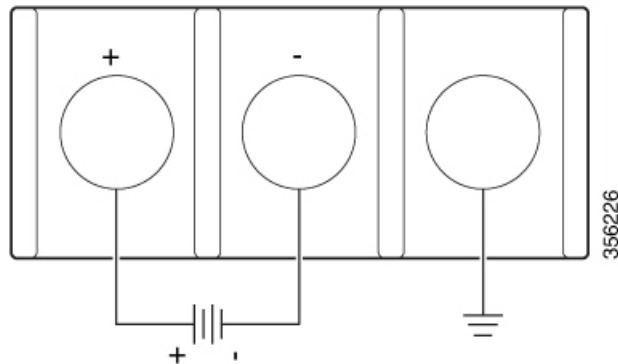
Figure 11: DC Connection with Ground

- Step 4** Torque all terminal block screws to 11 lbf-in.
- Step 5** Replace the terminal block safety cover and turn on the power at the power source.
- Step 6** Confirm that the power supply DC OK and PS OK LEDs are green.

Finding the Power Supply Module Serial Number

If you contact Cisco Technical Assistance regarding a power supply module, you need to know the serial number. See the following illustrations to find the serial number. You can also use the CLI to find out the serial number.

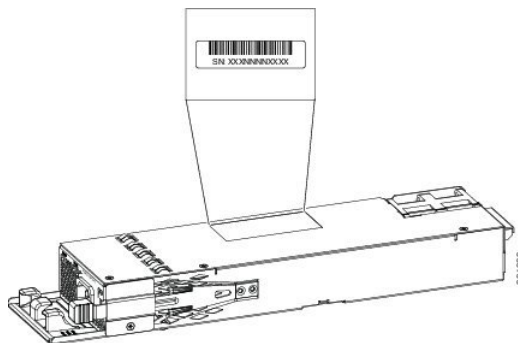
Figure 12: 1100-W AC Power Supply Serial Number

Figure 13: 715-W and 350-W AC Power Supply Serial Number

