



CHAPTER 1

Configuring Y.1731 (AIS and RDI)

The Catalyst 4500 series switch supports Y.1731 Ethernet Alarm Indication Signal function (ETH-AIS) and Ethernet Remote Defect Indication function (ETH-RDI) to provide fault and performance management for service providers in large networks. This chapter describes how to configure Y.1731 ETH-AIS and ETH-RDI.

This chapter contains these sections:

- [AIS and RDI Terminology, page 1-1](#)
- [About Y.1731, page 1-2](#)
- [Configuring Y.1731, page 1-4](#)
- [Displaying Y.1731 Information, page 1-6](#)

For complete command and configuration information for Y.1731, see the Cisco IOS feature module at this URL:

<http://www.cisco.com/en/US/docs/ios-xml/ios/cether/configuration/12-2sr/ce-cfm-y1731.html>

AIS and RDI Terminology

Term	Definition
CC	Ethernet OAM Continuity Check
CCM	Ethernet OAM Continuity Check Message
CCDB	Ethernet OAM Continuity Check Database
CFM	Ethernet Connectivity Fault Management
EI	Ethernet Infrastructure or EVC Infrastructure
EVC	Ethernet Virtual Circuit
LMEP	Local Mep
MEP	Maintenance Endpoint
MIP	Maintenance Intermediate Point

Term	Definition
OAM	Operations Administration and Maintenance
Service VLAN	The VLAN tag that uniquely identifies a Customer Service Instance within the Provider network

About Y.1731

These sections contain conceptual information about Y.1731:

- [Server MEP, page 1-2](#)
- [Alarm Indication Signal, page 1-2](#)
- [Ethernet Remote Defect Indication, page 1-3](#)

The advent of Ethernet as a metropolitan and WAN technology imposes a new set of Operations, Administration, and Maintenance (OAM) requirements on Ethernet's traditionally Enterprise-oriented functions. The expansion of this technology into the larger and more complex wider user base makes operational management of link uptime crucial. Isolating and responding to failures quickly directly affects the competitiveness of the service provider.

Server MEP

A Server MEP is a combined function of the server layer termination function and the server and ETH adaptation function. It issues frames with ETH-AIS information upon detecting a defect at the Server layer by the server layer termination function or the adaptation function.

A Virtual MEP represents the logical termination point of Connectivity Fault Management (CFM) MAs defined at the link or transport layer. A server MEP runs or is defined at Maintenance Level -1. For example, you could associate an outward-facing Server MEP with each termination point of IEEE 802.3ah OAM, or with each termination point of MPLS PW OAM.

Alarm Indication Signal

ETH-AIS allows you to suppress alarms when defects are detected at the server (sub) layer. Because of STP's ability to restore, you would not expect to apply ETH-AIS in the STP environments. For the Catalyst 4500 Metro switch, an administrator can enable and disable AIS in the STP environment.

You can enable or disable transmission of frames with ETH-AIS information on an MEP (or on a Server MEP).

You also can issue frames with ETH-AIS information at the client Maintenance Level by a MEP, including a Server MEP upon detecting defect conditions.

The defect conditions may include:

- Signal fail conditions with ETH-CC enabled
- AIS condition with ETH-CC disabled

For multipoint ETH connectivity, a MEP cannot determine the specific server (sub) layer entity that has encountered defect conditions upon receiving a frame with ETH-AIS information. More importantly, it cannot determine the associated subset of its peer MEPs for which it should suppress alarms because the received ETH-AIS information does not contain that information. When a MEP receives a frame with ETH-AIS information, it suppresses alarms for all peer MEPs whether there is still connectivity or not.

For a point-to-point ETH connection, however, a MEP has only one peer MEP. There is no ambiguity regarding the peer MEP for which it should suppress alarms when it receives the ETH-AIS information.

Only a MEP, including a Server MEP, is configured to issue frames with ETH-AIS information. Once the MEP detects a defect condition, it immediately starts transmitting periodic frames with ETH-AIS information at a configured client maintenance level. We send the AIS frames at a configured MIP level for an interface. A MEP continues to transmit periodic frames with ETH-AIS information until the defect condition is removed. Upon receiving a frame with ETH-AIS information, a MEP detects AIS condition and suppresses loss of continuity alarms associated with all its peer MEPs. A MEP resumes loss of continuity alarm generation upon detecting loss of continuity defect conditions in the absence of AIS condition.

Ethernet Remote Defect Indication

A MEP can use ETH-RDI to notify its peer MEPs that it detects a defect condition. ETH-RDI is used only when ETH-CC transmission is enabled.

ETH-RDI has the following two applications:

- Single-ended fault management—The receiving MEP detects an RDI defect condition, which is correlated with other defect conditions in this MEP and may cause a fault. The absence of received ETH-RDI information in a single MEP indicates the absence of defects in the entire maintenance.
- Contribution to far-end performance monitoring— It reflects a defect condition in the far-end which serves as input to the performance monitoring process.

A MEP that is in a defect condition transmits frames with ETH-RDI information. A MEP, upon receiving frames with ETH-RDI information, determines that its peer MEP has encountered a defect condition. For multipoint ETH connectivity, however, a MEP, upon receiving frames with ETH-RDI information, cannot determine the associated subset of its peer MEPs with which the MEP transmitting RDI information encounters defect conditions. It is because the transmitting MEP itself does not always have that information.

Figure 1-1 Generating and Propagating AIS Messages Upon a Defect (Link Fail)

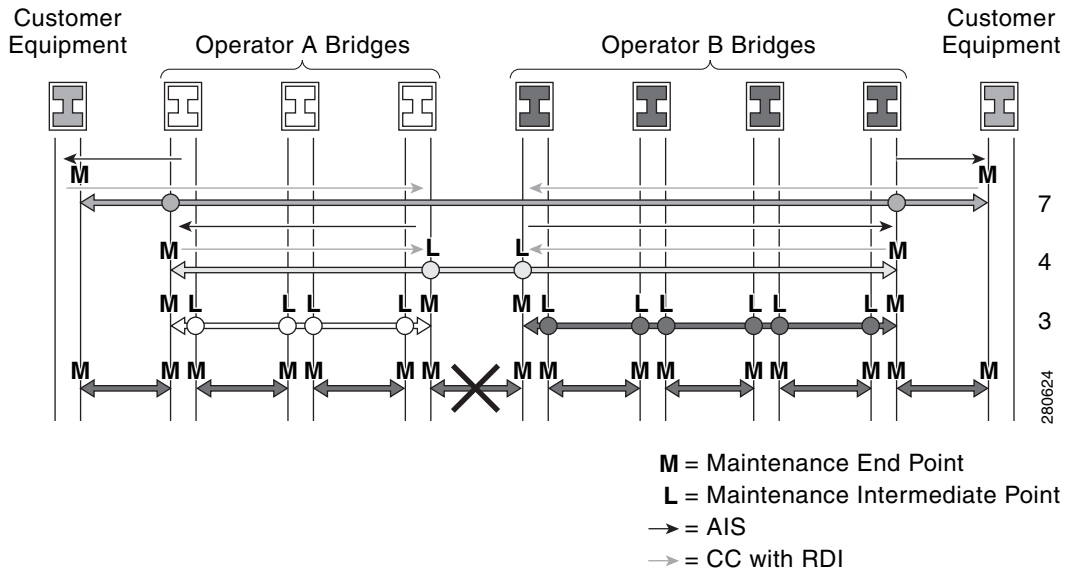

Configuring Y.1731



Note

Y.1731 is enabled by default.

These sections are included:

- [Y.1731 Configuration Guidelines, page 1-4](#)
- [Configuring AIS Parameters, page 1-5](#)
- [Clearing MEP from the AIS Defect Condition, page 1-6](#)
- [Clearing SMEP from the AIS Defect Condition, page 1-6](#)

Y.1731 Configuration Guidelines

Configuration guidelines and restrictions for Y.1731 include the following:

- Because of STP's restoration capability, do not expect ETH-AIS to be applied in the STP environments.
- AIS is enabled by default on a CFM maintenance domain. The following section illustrates the commands you can use to disable AIS on a maintenance domain. Likewise, RDI is a flag bit in the CC message. Provided CC transmission is enabled, the present RDI flag of the CC message is set to true or false.

Configuring AIS Parameters

To set the parameters for AIS, perform this task:

	Command	Purpose
Step 1	Switch# configure terminal	Enters global configuration mode.
Step 2	Switch (config)# ethernet cfm ais domain name vlan range	Enters <i>config-ais-mep-cfm</i> submode to configure parameters for all local Meps belonging to that per Maintenance Association (MA). <i>name</i> refers to the domain name. <i>range</i> represents VLAN IDs 100, 200-300, 400, 500, or 1-4095 For the domain name vlan range command only configurations that are VLAN disjoint or congruent are accepted.
Step 3	Switch(config-ais-mep-cfm)# disable	Disables AIS transmission.
Step 4	Switch(config-ais-mep-cfm)# period period	Sets the AIS transmission period.
Step 5	Switch(config-ais-mep-cfm)# level level	Establishes a maintenance level to send AIS frames for MEPs belonging to MA. Valid levels are 0 to 7.
Step 6	Switch(config-ais-mep-cfm)# expiry-threshold <i>threshold</i>	Sets the AIS expiry threshold. By default, expiry threshold is 3.5. With this CLI we can change the expiry threshold parameter for MA.
Step 7	Switch(config-ais-mep-cfm)# express alarm	Configures alarm suppression when an AIS message causes the MEP enters an AIS defect condition.
Step 8	Switch(config-ais-mep-cfm)# exit	Returns to global configuration.
Step 9	Switch(config)# [no] ethernet cfm ais link-status global	Enters <i>config-ais-link-cfm</i> submode, enabling you to configure parameters required to follow when link status goes down.
Step 10	Switch(config-if)# [no] ethernet cfm ais link-status period period	Configures ETH-AIS transmission period generated by the link-status on the interface.
Step 11	Switch(config-if)# [no] ethernet cfm ais link-status level level	Configures maintenance level to send AIS frames transmitted by the link-status on the interface.
Step 12	end	Returns to privileged EXEC mode.
Step 13	Switch# show ethernet cfm smep interface name Switch# show ethernet cfm maintenance-points local detail Switch# show ethernet cfm maintenance-points remote detail Switch# show ethernet cfm error	Verifies the configuration.
Step 14	Switch# show running-config	Verifies your entries.
Step 15	Switch# copy running-config startup-config	(Optional) Saves your entries in the configuration file.

Use the **no** versions of the commands to remove the configuration or return to the default configurations.

Clearing MEP from the AIS Defect Condition

To clear the MEP, enter one of the following commands:

```
Switch# clear ethernet cfm ais domain domain_name mpid local mpid vlan vlan#
Switch# clear ethernet cfm ais domain domain_name mpid local mpid evc evc_name
```

Clearing SMEP from the AIS Defect Condition

To clear the CSMP, enter one of the following commands:

```
Switch# clear ethernet cfm ais link-status interface interface_name
Switch# clear ethernet cfm error
```



Note

This operation also clears all error conditions including AIS.

Displaying Y.1731 Information

To display Y.1731 information, you can use the following commands ([Table 1-1](#)).

Table 1-1 *Displaying Y.1731 Information*

Command	Purpose
<code>show ethernet cfm maintenance-point local detail</code>	Displays AIS status and defect condition on local maintenance points.
<code>show ethernet cfm smep [interface <name>]</code>	Displays AIS status and defect condition on SMEP.
<code>show ethernet cfm error</code>	Displays errors due to AIS defect condition.
<code>show ethernet cfm maintenance-points remote [detail</code>	Displays AIS status and defect Condition on remote maintenance points.

This example shows how to track the RDI defect and to verify the configuration parameters:

```
Switch# show ethernet cfm main local detail
MEP Settings:
-----
MPID: 1109
DomainName: PROVIDER_DOMAIN
Level: 4
Direction: I
EVC: evc_1
Interface: Gi3/1
CC-Status: Enabled
MAC: 001b.d550.91fd
Defect Condition: No Defect
presentRDI: FALSE (RDI defect is NOT present)
AIS-Status: Enabled
AIS Period: 60000(ms)
AIS Expiry Threshold: 3.5
Level to transmit AIS: Default
Suppress Alarm configuration: Enabled
Suppressing Alarms: No

MIP Settings:
-----
```

```

Level Type Port MAC
7 MIP Gi3/1 001b.d550.91fd
4 MIP Te1/2 001b.d550.91fd
Switch#
*Feb 18 05:40:35.659: %ETHER_CFM-6-ENTER_AIS: local mep with mpid 1109 level 4 id 100 dir
I Interface GigabitEthernet3/1 enters AIS defect condition (gi3/2 enters AIS state)
Switch# show ethernet cfm main local detail
MEP Settings:
-----
MPID: 1109
DomainName: PROVIDER_DOMAIN
Level: 4
Direction: I
EVC: evc_1
Interface: Gi3/1
CC-Status: Enabled
MAC: 001b.d550.91fd
Defect Condition: AIS
presentRDI: TRUE (RDI defect IS present)
AIS-Status: Enabled
AIS Period: 60000(ms)
AIS Expiry Threshold: 3.5
Level to transmit AIS: Default
Suppress Alarm configuration: Enabled
Suppressing Alarms: Yes

MIP Settings:
-----
Level Type Port MAC
7 MIP Gi3/1 001b.d550.91fd
4 MIP Te1/2 001b.d550.91fd
Switch# show ethernet cfm error
Level Vlan MPID Remote MAC Reason Service ID
4 100 2101 001d.4566.aa3d 0 lifetime TLV customerX
4 100 - 001b.d550.91fd Receive AIS customerX
Switch#
*Feb 18 05:51:08.567: %ETHER_CFM-6-EXIT_AIS: local mep with mpid 1109 level 4 id 100 dir I
Interface GigabitEthernet3/1 exited AIS defect condition (gi3/1 exits AIS state)
Switch# show ethernet cfm main local detail
MEP Settings:
-----
MPID: 1109
DomainName: PROVIDER_DOMAIN
Level: 4
Direction: I
EVC: evc_1
Interface: Gi3/1
CC-Status: Enabled
MAC: 001b.d550.91fd
Defect Condition: No Defect
presentRDI: FALSE (RDI defect is not present anymore)
AIS-Status: Enabled
AIS Period: 60000(ms)
AIS Expiry Threshold: 3.5
Level to transmit AIS: Default
Suppress Alarm configuration: Enabled
Suppressing Alarms: No

MIP Settings:
-----
Level Type Port MAC
7 MIP Gi3/1 001b.d550.91fd
4 MIP Te1/2 001b.d550.91fd
Switch#

```

