



Cisco Nexus 93180YC-FX3S NX-OS Mode Switch Hardware Installation Guide

First Published: 2020-07-22

Last Modified: 2024-11-01

Americas Headquarters

Cisco Systems, Inc.
170 West Tasman Drive
San Jose, CA 95134-1706
USA
<http://www.cisco.com>
Tel: 408 526-4000
800 553-NETS (6387)
Fax: 408 527-0883

THE SPECIFICATIONS AND INFORMATION REGARDING THE PRODUCTS REFERENCED IN THIS DOCUMENTATION ARE SUBJECT TO CHANGE WITHOUT NOTICE. EXCEPT AS MAY OTHERWISE BE AGREED BY CISCO IN WRITING, ALL STATEMENTS, INFORMATION, AND RECOMMENDATIONS IN THIS DOCUMENTATION ARE PRESENTED WITHOUT WARRANTY OF ANY KIND, EXPRESS OR IMPLIED.

The Cisco End User License Agreement and any supplemental license terms govern your use of any Cisco software, including this product documentation, and are located at: <http://www.cisco.com/go/softwareterms>. Cisco product warranty information is available at <http://www.cisco.com/go/warranty>. US Federal Communications Commission Notices are found here <http://www.cisco.com/c/en/us/products/us-fcc-notice.html>.

IN NO EVENT SHALL CISCO OR ITS SUPPLIERS BE LIABLE FOR ANY INDIRECT, SPECIAL, CONSEQUENTIAL, OR INCIDENTAL DAMAGES, INCLUDING, WITHOUT LIMITATION, LOST PROFITS OR LOSS OR DAMAGE TO DATA ARISING OUT OF THE USE OR INABILITY TO USE THIS MANUAL, EVEN IF CISCO OR ITS SUPPLIERS HAVE BEEN ADVISED OF THE POSSIBILITY OF SUCH DAMAGES.

Any products and features described herein as in development or available at a future date remain in varying stages of development and will be offered on a when-and if-available basis. Any such product or feature roadmaps are subject to change at the sole discretion of Cisco and Cisco will have no liability for delay in the delivery or failure to deliver any products or feature roadmap items that may be set forth in this document.

Any Internet Protocol (IP) addresses and phone numbers used in this document are not intended to be actual addresses and phone numbers. Any examples, command display output, network topology diagrams, and other figures included in the document are shown for illustrative purposes only. Any use of actual IP addresses or phone numbers in illustrative content is unintentional and coincidental.

The documentation set for this product strives to use bias-free language. For the purposes of this documentation set, bias-free is defined as language that does not imply discrimination based on age, disability, gender, racial identity, ethnic identity, sexual orientation, socioeconomic status, and intersectionality. Exceptions may be present in the documentation due to language that is hardcoded in the user interfaces of the product software, language used based on RFP documentation, or language that is used by a referenced third-party product.

Cisco and the Cisco logo are trademarks or registered trademarks of Cisco and/or its affiliates in the U.S. and other countries. To view a list of Cisco trademarks, go to this URL: [www.cisco.com go trademarks](http://www.cisco.com/go/trademarks). Third-party trademarks mentioned are the property of their respective owners. The use of the word partner does not imply a partnership relationship between Cisco and any other company. (1721R)

© 2020 –2024 Cisco Systems, Inc. All rights reserved.



CONTENTS

CHAPTER 1

Overview 1

Overview 1

CHAPTER 2

Preparing the Site 7

Temperature Requirements 7

Humidity Requirements 7

Altitude Requirements 7

Dust and Particulate Requirements 8

Minimizing Electromagnetic and Radio Frequency Interference 8

Shock and Vibration Requirements 9

Grounding Requirements 9

Planning for Power Requirements 9

Airflow Requirements 10

Rack and Cabinet Requirements 11

Clearance Requirements 11

CHAPTER 3

Installing the Chassis 13

Safety 13

Installation Options with Rack-Mount Kits 16

Airflow Considerations 17

Installation Guidelines 17

Unpacking and Inspecting the Switch 18

Installing the Switch Using the NXK-ACC-KIT-1RU Rack-Mount Kit 18

Installing the Airflow Sleeve (N9K-AIRFLOW-SLV) 22

Grounding the Chassis 23

Starting the Switch 25

CHAPTER 4	Connecting the Switch to the Network	27
	Overview of Network Connections	27
	Connecting a Console to the Switch	27
	Creating the Initial Switch Configuration	29
	Setting Up the Management Interface	30
	Connecting Interface Ports to Other Devices	30

CHAPTER 5	Replacing Components	33
	Replacing a Fan Module	33
	Removing a Fan Module	33
	Installing a Fan Module	34
	Replacing a Power Supply Module	34
	Removing an AC Power Supply	34
	Removing an HVAC/HVDC Power Supply	35
	Removing a DC Power Supply	36
	Installing an AC Power Supply	36
	Installing an HVAC/HVDC Power Supply	37
	Installing a DC Power Supply	38

APPENDIX A	Rack Specifications	41
	Overview of Racks	41
	General Requirements for Cabinets and Racks	41
	Requirements Specific to Standard Open Racks	42
	Requirements Specific to Perforated Cabinets	42
	Cable Management Guidelines	42

APPENDIX B	System Specifications	43
	Environmental Specifications	43
	Switch Dimensions	43
	Switch and Module Weights and Quantities	44
	Transceiver and Cable Specifications	44
	Switch Power Input Requirements	44
	Power Specifications	45

650-W AC Power Supply Specifications	45
1200-W HVAC/HVDC Power Supply Specifications	45
930-W DC Power Supply Specifications	46
Power Cable Specifications	46
Power Cable Specifications for AC Power Supplies	47
HVAC/HVDC Power Cables Supported by ACI-Mode and NX-OS Mode Switches	48
DC Power Cable Specifications	48
Regulatory Standards Compliance Specifications	48

APPENDIX C**LEDs 51**

Switch Chassis LEDs	51
Fan Module LEDs	52
Power Supply LEDs	52

APPENDIX D**Additional Kits 55**

Rack Mount Kit NXK-ACC-KIT-1RU	55
Airflow Sleeve	56



CHAPTER 1

Overview

- [Overview, on page 1](#)

Overview

The Cisco Nexus 93180YC-FX3S switch (N9K-C93180YC-FX3S) is a 1-rack unit (RU), fixed-port switch designed for deployment in data centers. This switch has these ports:

- 48 100M/1/10/25-Gigabit Ethernet SFP28 ports (ports 1-48).
- 6 10/25/40/50/100-Gigabit I28 ports (ports 49-54)
- One management port (one 10/100/1000BASE-T port)
- One console port (RS-232)
- 1 USB port

This switch includes these user-replaceable components:

- Fan modules (four) with these airflow choices:
 - Port-side exhaust fan module with blue coloring (NXA-FAN-35CFM-PE)
 - Port-side intake fan module with burgundy coloring (NXA-FAN-35CFM-PI)



Note *Table 1: Fan Speeds for This Switch*

	Port-Side Intake Fan Speed %	Port-Side Exhaust Fan Speed %
Typical/Minimum	50%	70%
Maximum	100%	100%



Note This switch runs with +1 redundancy mode, so that if one fan fails, the switch can sustain operation. But if a second fan fails, this switch is not designed to sustain operation. Before waiting to reach major threshold temperature, the switch will power down due to **Powered-down due to fan policy trigger**.



Note Each fan module has two rotors. The switch can function normally if one rotor inside any one fan module fails. In case of more than one rotor failure, the switch issues a warning and powers down in 2 minutes.

- Power supply modules (two—One for operations and one for redundancy [1+1]) with these choices:
 - 650-W port-side exhaust AC power supply with blue coloring (NXA-PAC-650W-PE)
 - 650-W port-side intake AC power supply with burgundy coloring (NXA-PAC-650W-PI)
 - 1200-W HVAC/HVDC power supply with dual-direction airflow white coloring (N9K-PUV-1200W)
 - 930-W port-side exhaust DC power supply with blue coloring (NXA-PDC-930W-PE)
 - 930-W port-side intake DC power supply with burgundy coloring (NXA-PDC-930W-PI)



Note All fan modules and power supplies must use the same airflow direction.



Note This switch may present access issues if installed between switches with greater chassis depth. Please consider this before installation.

Deployment Scheme for SFP-10G-T-X Transceivers

The figure shows the maximum configuration density of SFP-10G-T-X SFP+ transceivers for this switch.

1	3	5	7	9	11	13	15	17	19	21	23	25	27	29	31	33	35	37	39	41	43	45	47	49	51	53
2	4	6	8	10	12	14	16	18	20	22	24	26	28	30	32	34	36	38	40	42	44	46	48	50	52	54

503038

	<p>Active Port deploying the SFP+ 10GBASE-T transceiver, with max power consumption up to 2.5W.</p> <p>Once configured with “media-type 10g-tx” in NX-OS or “Link Level Policy -> Physical Media Type -> SFP 10G TX” in ACI, these ports can deploy SFP-10G-T-X. Without such configuration, they behave like normal ports.</p>
--	---

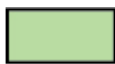
	<p>Port Shutdown or Active with Passive Copper Cables only (Max. power consumption up to 0.1W).</p> <p>Once 10g-tx is configured on yellow ports, ports to the left, right, top and bottom of the yellow port are referenced as blue ports. These adjacent ports will then support only low power Passive Copper DAC cable, or these can be left empty to conserve power. If 10g-tx configuration is removed from adjacent yellow ports, the blue ports will revert to behaving like normal ports.</p>
	<p>Active Ports 17 - 36 deploying any Cisco 1/10/25G optics (SFP, SFP+, SFP28) EXCLUDING SFP+ 10GBASE-T, with max power consumption up to 1.5W and Active Ports 49 - 54 deploying any Cisco QSFP, QSFP+, QSFP28 with max power consumption up to 3.5W. These ports are not part of any scheme and can deploy all regular Cisco optics and behave like normal ports.</p>

The figure shows the switch features on the front side of the chassis.

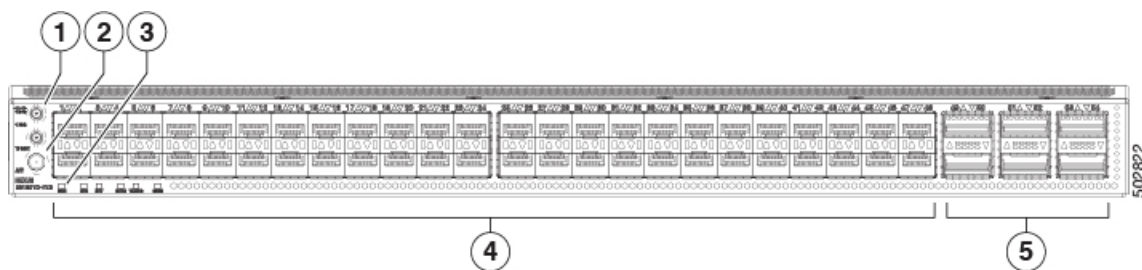

1	1PPS and 10MHz SMB ports	4	48 100M/1/10/25-Gigabit Ethernet SFP28 ports
2	GPS/GNSS antenna connector	5	6 10/25/40/50/100-Gigabit QSFP28 ports
3	LEDs: The function is the same for the port and rear side of switch		



Note Time of Day and PTP GM is not supported.

To determine which transceivers, adapters, and cables support this switch, see the [Cisco Transceiver Modules Compatibility Information](#) document.

The figure shows the switch features on the power supply side of the chassis, the back view.

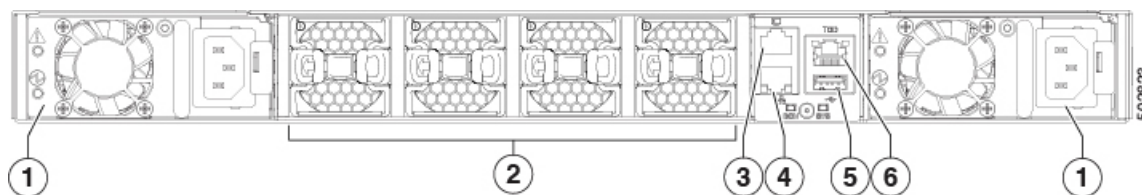

1	Power supply modules (1 or 2) (AC power supplies shown) with slots numbered 1 (left) and 2 (right)	4	Management port (RJ45)
---	--	---	------------------------

2	Fan modules (4) with slots numbered from 1 (left) to 4 (right)	5	USB port
3	Console port	6	ToD port

Table 2: ToD/1PPS RS422 Interface-RJ-45 Pinout

Pin	Signal_name	Description
1	NC	No Connect
2	NC	No Connect
3	1PPS_N	1PPS RS422
4	GND	-
5	GND	-
6	1PPS_P	1PPS RS422
7	TOD_N	Time of Day (ToD) RS422
8	TOD_P	Time of Day (ToD) RS422

The figure shows the side of the chassis.

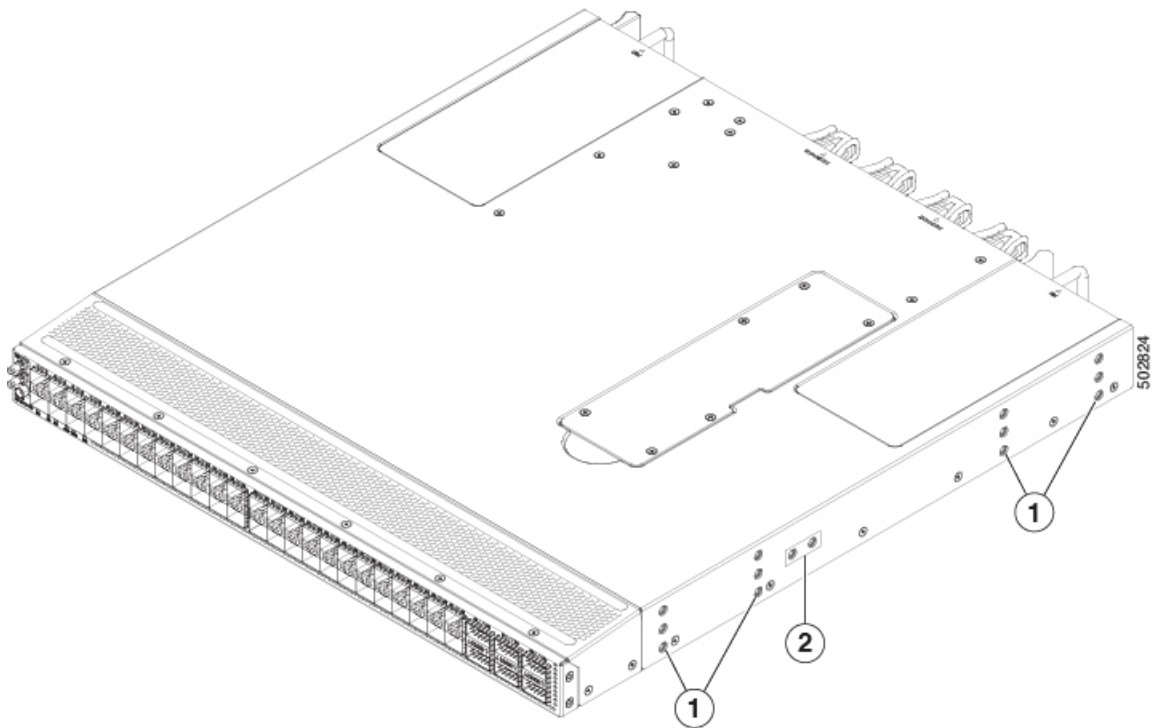

1	Screw holes for mounting brackets	2	Grounding pad
---	-----------------------------------	---	---------------

Depending on whether you plan to position the ports in a hot or cold aisle, order the fan and power supply modules with port-side intake or port-side exhaust airflow. For port-side intake airflow, the fan and power supplies have burgundy coloring. For port-side exhaust airflow, the fan and power supplies have blue coloring.

The fan and power supply modules are field replaceable. Replace one fan module or one power supply module during operations as long as the other modules are installed and operating. If you have only one power supply installed, install the replacement power supply in the open slot before removing the original power supply.



Note All fan and power supply modules must have the same direction of airflow. Otherwise, the switch can overheat and shut down.



Caution If the switch has port-side intake airflow (burgundy coloring for fan modules), locate the ports in the cold aisle. If the switch has port-side exhaust airflow (blue coloring for fan modules), locate the ports in the hot aisle. If you locate the air intake in a hot aisle, the switch can overheat and shut down.



CHAPTER 2

Preparing the Site

- [Temperature Requirements, on page 7](#)
- [Humidity Requirements, on page 7](#)
- [Altitude Requirements, on page 7](#)
- [Dust and Particulate Requirements, on page 8](#)
- [Minimizing Electromagnetic and Radio Frequency Interference, on page 8](#)
- [Shock and Vibration Requirements, on page 9](#)
- [Grounding Requirements, on page 9](#)
- [Planning for Power Requirements, on page 9](#)
- [Airflow Requirements, on page 10](#)
- [Rack and Cabinet Requirements, on page 11](#)
- [Clearance Requirements, on page 11](#)

Temperature Requirements

The operating temperature of the switch is 32 to 104 degrees Fahrenheit (0 to 40 degrees Celsius). The non-operating temperature of the switch is -40 to 158 degrees Fahrenheit (-40 to 70 degrees Celsius).

Humidity Requirements

High humidity can cause moisture to enter the switch. Moisture can cause corrosion of internal components and degradation of properties such as electrical resistance, thermal conductivity, physical strength, and size. The switch is rated to withstand from 5- to 95-percent (nonoperating) and 5- to 90-percent (operating) relative humidity.

Climate-controlled buildings usually maintain an acceptable level of humidity for the switch equipment. If the switch is located in an unusually humid location, use a dehumidifier to maintain the humidity within an acceptable range.

Altitude Requirements

Altitude rating is 10,000 ft (3048 m). For China, it is 6,562 ft (2000 m).

Dust and Particulate Requirements

Exhaust fans cool power supplies. System fans cool switches by drawing in air and exhausting air out through various openings in the chassis. Fans also introduce dust and other particles, causing contaminant buildup in the switch and increased internal chassis temperature. Dust and particles can act as insulators and interfere with the mechanical components in the switch. Keep a clean operating environment to reduce the negative effects of dust and other particles.

In addition to keeping your environment free of dust and particles, use these precautions to avoid contamination of your switch:

- Do not smoke near the switch.
- Do not eat or drink near the switch.

Minimizing Electromagnetic and Radio Frequency Interference

Electromagnetic interference (EMI) and radio frequency interference (RFI) from the switch can adversely affect other devices, such as radio and television (TV) receivers. Radio frequencies that emanate from the switch can also interfere with cordless and low-power telephones. Conversely, RFI from high-power telephones can cause spurious characters to appear on the switch monitor.

RFI is defined as any EMI with a frequency above 10 kHz. This type of interference can travel from the switch to other devices through the power cable and power source or through the air as transmitted radio waves. The Federal Communications Commission (FCC) publishes specific regulations to limit the amount of EMI and RFI that are emitted by computing equipment. Each switch meets these FCC regulations.

To reduce the possibility of EMI and RFI, use these guidelines:

- Cover all open expansion slots with a blank filler plate.
- Always use shielded cables with metal connector shells for attaching peripherals to the switch.

When wires are run for any significant distance in an electromagnetic field, interference can occur to the signals on the wires with these implications:

- Bad wiring can result in radio interference emanating from the plant wiring.
- Strong EMI, especially when it is caused by lightning or radio transmitters, can destroy the signal drivers and receivers in the chassis and even create an electrical hazard by conducting power surges through lines into equipment.



Note To predict and prevent strong EMI, consult experts in radio frequency interference (RFI).

The wiring is unlikely to emit radio interference if you use a twisted-pair cable with a good distribution of grounding conductors. If you exceed the recommended distances, use a high-quality twisted-pair cable with one ground conductor for each data signal, when applicable.

**Caution**

If the wires exceed the recommended distances, or if wires pass between buildings, give special consideration to the effect of a lightning strike in your vicinity. The electromagnetic pulse that is caused by lightning or other high-energy phenomena can easily couple enough energy into unshielded conductors to destroy electronic switches. Consult experts in electrical surge suppression and shielding if you have had similar problems in the past.

Shock and Vibration Requirements

The switch has been shock- and vibration-tested for operating ranges, handling, and earthquake standards.

Grounding Requirements

The switch is sensitive to variations in voltage that is supplied by the power sources. Overvoltage, undervoltage, and transients (spikes) can erase data from memory or cause components to fail. To protect against these types of problems, ensure that there is an earth-ground connection for the switch. Connect the grounding pad on the switch either directly to the earth-ground connection or to a fully bonded and grounded rack.

When the chassis is properly installed in a grounded rack, the switch is grounded because it has a metal-to-metal (no paint, stain, dirt, or anything else on it) connection to the rack. Alternatively, ground the chassis by using a customer-supplied grounding cable that meets your local and national installation requirements. For U.S. installations, we recommend 6-AWG wire. Connect your grounding cable to the chassis with a grounding lug (provided in the switch accessory kit) and to the facility ground.

**Note**

You automatically ground AC power supplies when you connect them to AC power sources. For DC power supplies, you must connect a grounding wire when wiring the power supply to the DC power source.

**Note**

Create an electrical conducting path between the product chassis and the metal surface of the enclosure, or rack in which it is mounted, or to a grounding conductor. Provide electrical continuity by using thread-forming type mounting screws that remove any paint or non-conductive coatings and establish a metal-to-metal contact. Remove any paint or other non-conductive coatings on the surfaces between the mounting hardware and the enclosure or rack. Clean the surfaces and apply an antioxidant before installation.

Planning for Power Requirements

The switch includes two power supplies (1-to-1 redundancy with current sharing) in one of these combinations:

- Two 650-W AC power supplies (NEBS compliant)
- Two 1200-W HVAC/HVDC power supplies
- Two 930-W DC power supplies



Note For 1+1 redundancy, you must use two power sources and connect each power supply to a separate power source.

The power supplies are rated to output up to 650 W (AC power supplies) but the switch requires less than that amount of power from the power supply. To operate the switch, you must provision enough power from the power source to cover the requirements of both the switch and a power supply. Typically, this switch and a power supply require 500 W of power input from the power source, but you must provision as much as 625 W of power input from the power source to cover peak demand.



Note Some of the power supply modules have rating capabilities that exceed the switch requirements. When calculating your power requirements, use the switch requirements to determine the amount of power that is required for the power supplies.

To minimize the possibility of circuit failure, verify that each power-source circuit that is used by the switch is dedicated to the switch.



Note This Warning applies to DC input application.



Warning **Statement 1033**—Safety Extra-Low Voltage (SELV)—IEC 60950/ES1—IEC 62368 DC Power Supply

To reduce the risk of electric shock, connect the unit to a DC power source that complies with the SELV requirements in IEC 60950-based safety standards or ES1 and PS1 requirements in IEC 62368-based safety standards or to a Class 2 power supply.



Note We recommend 8-AWG wire for DC installations in the U.S.

Airflow Requirements

The switch is positioned with its ports in either the front or the rear of the rack, depending on your cabling and maintenance requirements. To identify the airflow options for your switch, see the user-replaceable components in the *Overview* section of this document. Position the fan and power supply modules to move the coolant air from the cold aisle to the hot aisle in one of these ways:

- Port-side exhaust airflow—Cool air enters the chassis through the fan and power supply modules in the cold aisle and exhausts through the port end of the chassis in the hot aisle.
- Port-side intake airflow—Cool air enters the chassis through the port end in the cold aisle and exhausts through the fan and power supply modules in the hot aisle.

Identify the airflow direction of each fan and power supply module by its coloring.

- Blue coloring indicates port-side exhaust airflow.



Note To prevent the switch from overheating and shutting down, position the air intake for the switch in a cold aisle. The fan and power supply modules must have the same direction of airflow. To change the airflow direction for the switch, shutdown the switch before changing the modules.

Rack and Cabinet Requirements

Install these types of racks or cabinets for your switch:

- Standard perforated cabinets
- Solid-walled cabinets with a roof fan tray (bottom-to-top cooling)
- Standard open four-post Telco racks

Work with your cabinet vendors to determine which of their cabinets meet these requirements or see the Cisco Technical Assistance Center (TAC) for recommendations:

- Use a standard 19-inch (48.3-cm), four-post Electronic Industries Alliance (EIA) cabinet or rack with mounting rails that conform to English universal hole spacing per section 1 of the ANSI/EIA-310-D-1992 standard.
- The depth of a four-post rack must be 24 to 32 inches (61.0 to 81.3 cm) between the front and rear mounting rails (for proper mounting of the bottom-support brackets or other mounting hardware).

Also, you must have power receptacles that are located within reach of the power cords that are used with the switch.



Warning **Statement 1048**—Rack Stabilization

The rack stabilizing mechanism must be in place, or the rack must be bolted to the floor before installation or servicing. Failure to stabilize the rack can cause bodily injury.

Clearance Requirements

Provide the chassis with adequate clearance between the chassis and any other rack, device, or structure so that you can properly install the it. Provide the chassis with adequate clearance to route cables, provide airflow, and maintain the switch. For the clearances required for an installation of this chassis in a four-post rack, see the figure.

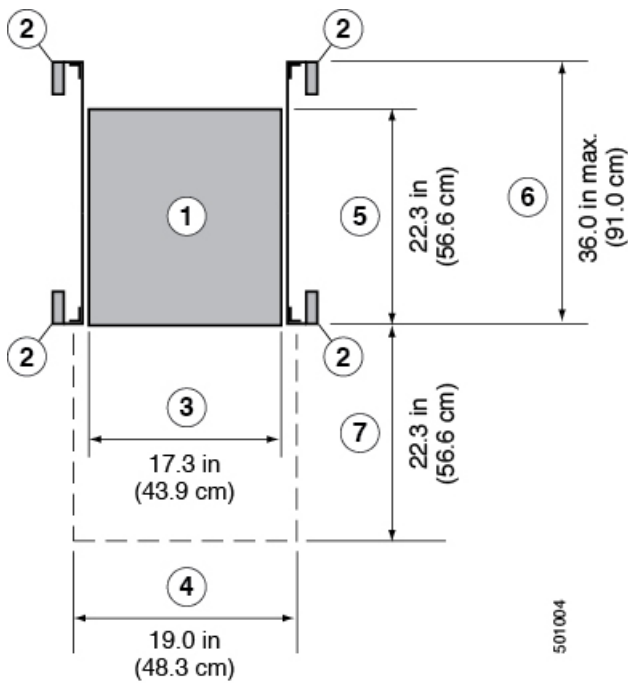

1	Chassis	5	Depth of the chassis
2	Vertical rack-mount posts and rails	6	Maximum extension of the bottom-support rails 36.0 in (91.0 cm)
3	Chassis width 17.3 in (43.9 cm)	7	Depth of the front clearance area (equal to the depth of the chassis).
4	Width of the front clearance area (equal to the width of the chassis with two rack-mount brackets that are attached to it). 19.0 in (48.3 cm)		



Note Both the front and rear of the chassis must be open to both aisles for airflow.



CHAPTER 3

Installing the Chassis

- [Safety](#), on page 13
- [Installation Options with Rack-Mount Kits](#), on page 16
- [Airflow Considerations](#), on page 17
- [Installation Guidelines](#), on page 17
- [Unpacking and Inspecting the Switch](#), on page 18
- [Installing the Switch Using the NXK-ACC-KIT-1RU Rack-Mount Kit](#), on page 18
- [Installing the Airflow Sleeve \(N9K-AIRFLOW-SLV\)](#), on page 22
- [Grounding the Chassis](#), on page 23
- [Starting the Switch](#), on page 25

Safety

Before you install, operate, or service the switch, see the *Regulatory, Compliance, and Safety Information for the Cisco Nexus 3000 and 9000 Series* content for important Safety Information.



Warning **Statement 1071**—Warning Definition

IMPORTANT SAFETY INSTRUCTIONS

Before you work on any equipment, be aware of the hazards involved with electrical circuitry and be familiar with standard practices for preventing accidents. Read the installation instructions before using, installing, or connecting the system to the power source. Use the statement number provided at the end of each warning statement to locate its translation in the translated safety warnings for this device.

SAVE THESE INSTRUCTIONS



Warning **Statement 1089**—Instructed and Skilled Person Definitions

An instructed person is someone who has been instructed and trained by a skilled person and takes the necessary precautions when working with equipment.

A skilled person or qualified personnel is someone who has training or experience in the equipment technology and understands potential hazards when working with equipment.

There are no serviceable parts inside. To avoid risk of electric shock, do not open.



Warning Statement 1074—Comply with Local and National Electrical Codes

To reduce risk of electric shock or fire, installation of the equipment must comply with local and national electrical codes.



Note Statement 407—Japanese Safety Instruction

You are strongly advised to read the safety instruction before using the product.

<https://www.cisco.com/web/JP/techdoc/pldoc/pldoc.html>

When installing the product, use the provided or designated connection cables/power cables/AC adapters.

〈製品仕様における安全上の注意〉
www.cisco.com/web/JP/techdoc/index.html

接続ケーブル、電源コードセット、ACアダプタ、バッテリーなどの部品は、必ず添付品または指定品をご使用ください。添付品・指定品以外をご使用になると故障や動作不良、火災の原因となります。また、電源コードセットは弊社が指定する製品以外の電気機器には使用できないためご注意ください。



Warning Statement 1017—Restricted Area

This unit is intended for installation in restricted access areas. Only skilled, instructed, or qualified personnel can access a restricted access area.



Warning Statement 1030—Equipment Installation

Only trained and qualified personnel should be allowed to install, replace, or service this equipment.



Warning Statement 1091—Installation by an Instructed Person

Only an instructed person or skilled person should be allowed to install, replace, or service this equipment. See statement 1089 for the definition of an instructed or skilled person.

There are no serviceable parts inside. To avoid risk of electric shock, do not open.



Warning Statement 1028—More Than One Power Supply

This unit might have more than one power supply connection. To reduce risk of electric shock, remove all connections to de-energize the unit.

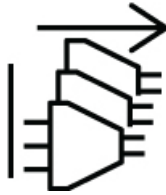

Warning Statement 1003—Power Disconnection

To reduce risk of electric shock or personal injury, disconnect power before removing or replacing components or performing upgrades.



Warning Statement 1046—Installing or Replacing the Unit

To reduce risk of electric shock, when installing or replacing the unit, the ground connection must always be made first and disconnected last.

If your unit has modules, secure them with the provided screws.



Warning Statement 1022—Disconnect Device

To reduce the risk of electric shock and fire, a readily accessible disconnect device must be incorporated in the fixed wiring.



Warning Statement 1033—Safety Extra-Low Voltage (SELV)—IEC 60950/ES1—IEC 62368 DC Power Supply

To reduce the risk of electric shock, connect the unit to a DC power source that complies with the SELV requirements in IEC 60950-based safety standards or ES1 and PS1 requirements in IEC 62368-based safety standards or to a Class 2 power supply.



Warning Statement 1024—Ground Conductor

This equipment must be grounded. To reduce the risk of electric shock, never defeat the ground conductor or operate the equipment in the absence of a suitably installed ground conductor. Contact the appropriate electrical inspection authority or an electrician if you are uncertain that suitable grounding is available.

**Warning** **Statement 1032**—Lifting the Chassis

To prevent personal injury or damage to the chassis, never attempt to lift or tilt the chassis using the handles on modules, such as power supplies, fans, or cards. These types of handles are not designed to support the weight of the unit.

**Warning** **Statement 1006**—Chassis Warning for Rack-Mounting and Servicing

To prevent bodily injury when mounting or servicing this unit in a rack, you must take special precautions to ensure that the system remains stable. The following guidelines are provided to ensure your safety:

- This unit should be mounted at the bottom of the rack if it is the only unit in the rack.
- When mounting this unit in a partially filled rack, load the rack from the bottom to the top with the heaviest component at the bottom of the rack.
- If the rack is provided with stabilizing devices, install the stabilizers before mounting or servicing the unit in the rack.



Caution To prevent loss of input power, ensure the total maximum loads on the circuits supplying power to the switch are within the current ratings for the wiring and breakers.



Note For AC input application, please refer to the statement below:

**Warning** **Statement 1005**—Circuit Breaker

This product relies on the building's installation for short-circuit (overcurrent) protection. Ensure that the protective devices is rated not greater than 20A (North America), 16A (Europe), and 13A (UK).

Installation Options with Rack-Mount Kits

The rack-mount kit enables you to install the switch into racks of varying depths. Position the switch with easy access to either the port connections or the fan and power supply modules.

Install the switch using these rack-mount options:

- Rack-mount kit (NXX-ACC-KIT-1RU) which you can order from Cisco. This option offers you easy installation, greater stability, increased weight capacity, added accessibility, and improved removability with front and rear removal.
- Rack-mount kit (N3K-C3064-ACC-KIT) which you can order from Cisco.

The rack or cabinet that you use must meet the requirements listed in the section [General Requirements for Cabinets and Racks, on page 41](#).



Note You are responsible for verifying that your rack and rack-mount hardware comply with the guidelines that are described in this document.

Airflow Considerations

The switch comes with fan and power supply modules that have either port-side intake or port-side exhaust airflow for cooling the switch. If you are positioning the port end of the switch in a cold aisle, verify that the switch has port-side intake fan modules with burgundy coloring. If you are positioning the fan and power supply modules in a cold aisle, verify that the switch has port-side exhaust fan modules with blue colorings. All fan modules must have the same direction of airflow.

Each fan module includes two fan rotors that are counter rotating.

Installation Guidelines

When installing the switch, follow these guidelines:

- Ensure that there is adequate clearance space around the switch to allow for servicing the switch and for adequate airflow.
- Ensure that the chassis can be adequately grounded. If the switch is not mounted in a grounded rack, we recommend connecting the system ground on the chassis directly to an earth ground.
- Ensure that the site power meets the power requirements for the switch. If available, use an uninterruptible power supply (UPS) to protect against power failures.



Caution Avoid UPS types that use ferroresonant technology. These UPS types can become unstable with the switch, which can have substantial current draw fluctuations because of fluctuating data traffic patterns.

- Ensure that circuits are sized according to local and national codes. Typically, this often requires one or both of these:
 - AC power supplies typically require at least a 15-A or 20-A AC circuit, 100 to 240 VAC, and a frequency of 50 to 60 Hz.



Caution To prevent loss of input power, ensure the total maximum loads on the circuits supplying power to the switch are within the current ratings for the wiring and breakers.

Unpacking and Inspecting the Switch

Before you install the switch, unpack and inspect the switch for damage or missing components. If anything is missing or damaged, contact your customer service representative immediately.



Tip Keep the shipping container in case the chassis requires shipping at a later time.

Before you begin

Before you unpack the switch and before you handle any switch components, be sure that you are wearing a grounded electrostatic discharge (ESD) strap. To ground the strap, attach it directly to an earth ground or to a grounded rack or grounded chassis (there must be a metal-to-metal connection to the earth ground).

Procedure

-
- Step 1** Compare the shipment to the equipment list provided by your customer service representative and verify that you have received all items, including these:
- Accessory Kit
- Step 2** Check for damage and report any discrepancies or damage to your customer service representative. Have this information ready:
- Invoice number of shipper (see packing slip)
 - Model and serial number of the damaged unit
 - Description of damage
 - Effect of damage on the installation
-

Installing the Switch Using the NXK-ACC-KIT-1RU Rack-Mount Kit

To install the switch, attach front and rear mounting brackets to the switch, install slider rails on the rear of the rack, slide the switch onto the slider rails, and secure the switch to the front of the rack. Typically, the front of the rack is the side easiest to access for maintenance.



Note You must supply the eight 10-32 or 12-24 screws required to mount the slider rails and switch to the rack.

Before you begin

- Inspected the switch shipment to ensure that you have everything ordered.
- Verify that the switch rack-mount kit includes these parts:
 - Front rack-mount brackets (2)
 - Rear rack-mount brackets (2)
 - Slider rails (2)
 - M4 x 0.7 x 8-mm Phillips countersink screws (10-12)
- The rack is installed and secured to its location.

Procedure

Step 1

Install two front rack-mount brackets and the two rear rack-mount brackets to the switch.

a) Determine which end of the chassis is to be located in the cold aisle.

- If the switch has port-side intake modules (fan modules with burgundy coloring), position the switch so that its ports will be in the cold aisle.
- If the switch has port-side exhaust modules (fan modules with blue coloring), position the switch so that its fan and power supply modules will be in the cold aisle.

b) Position the front rack-mount bracket and the rear rack-mount bracket so that its screw holes are aligned to the screw holes on the side of the chassis.

Note You can align the holes in the rack-mount bracket to the holes on the side of the chassis (see the two ways to mount these brackets on a typical chassis, in the figure). The holes that you use depend on the requirements of your rack and the amount of clearance required for interface cables (3 inches [7.6 mm] minimum) and module handles (1 inch [2.5 mm] minimum).

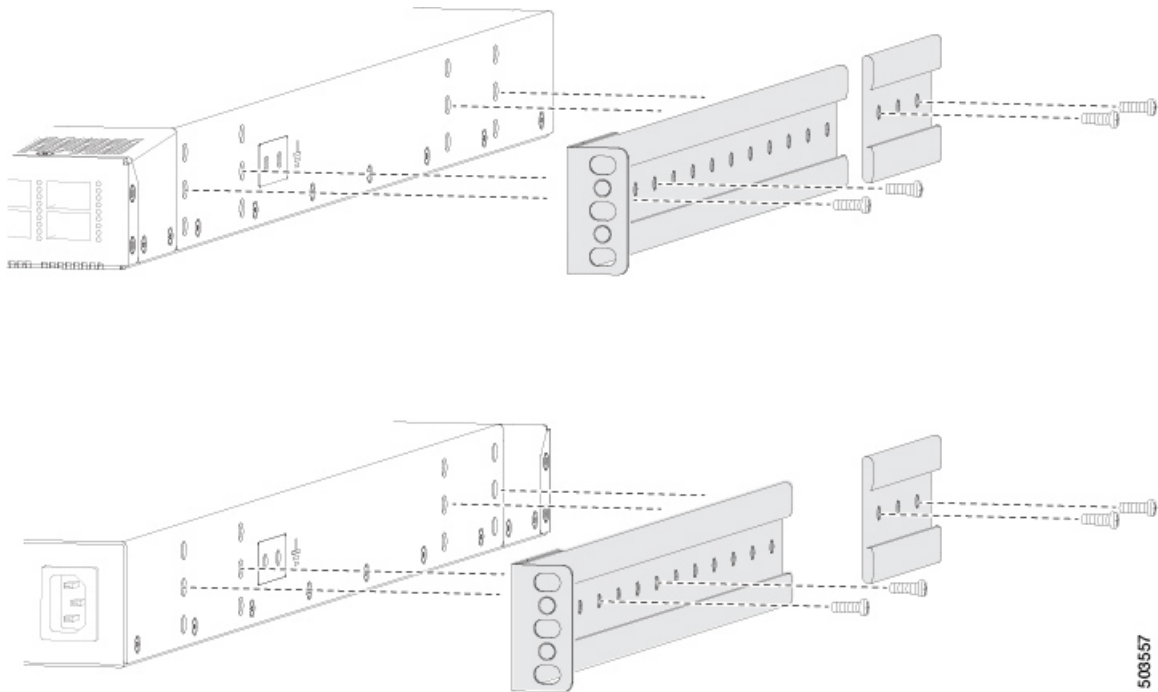

- c) Secure the front-mount bracket and the back-mount bracket to the chassis using four M4 screws and tighten each screw to 12 in-lb (1.36 N·m) of torque.
- d) Repeat Step 1 for the other front rack-mount bracket and the other back-mount bracket on the other side of the switch and be sure to position that bracket the same distance from the front of the switch.

Note Depending on the chassis depth, the back rack-mount bracket may not fit. In that case the back rack-mount bracket is not needed.

Step 2 If you are not installing the chassis into a grounded rack, attach a customer-supplied grounding wire to the chassis as explained in the [Grounding the Chassis, on page 23](#) section. If you are installing the chassis into a grounded rack, skip this step.

Step 3 Install the slider rails on the rack or cabinet.

- a) Determine which two posts of the rack or cabinet you should use for the slider rails. Of the four vertical posts in the rack or cabinet, two will be used for the front-mount brackets attached to the easiest accessed end of the chassis. The other two posts will have the slider rails.
- b) Position a slider rail at the desired level on the back side of the rack and use 12-24 screws or 10-32 screws, depending on the rack thread type. To attach the rails to the rack (see the figure). Tighten 12-24 screws to 30 in-lb (3.39 N·m) of torque and tighten 10-32 screws to 20 in-lb (2.26 Nm) of torque.

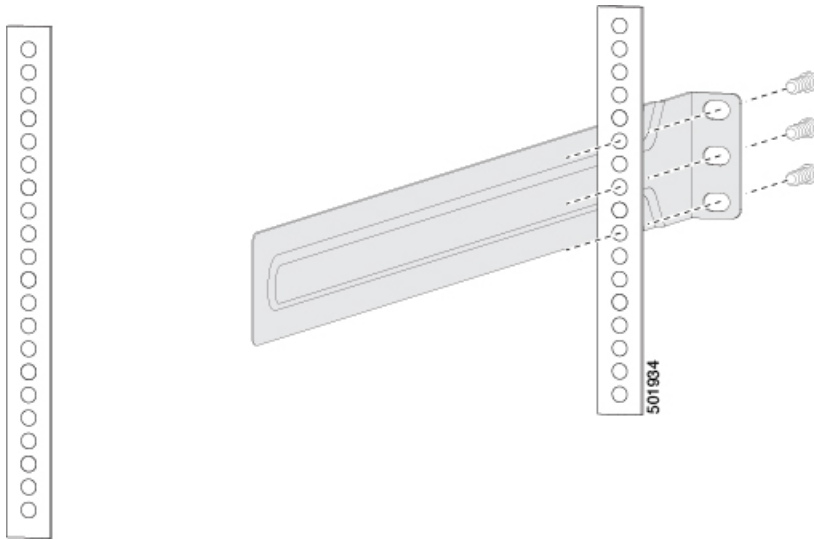

- c) Repeat Step 3 to attach the other slider rail to the other side of the rack.

Make sure that the slider rails are at the same level. Use a level tool, tape measure, or carefully count the screw holes in the vertical mounting rails.

Step 4 Insert the switch into the rack and attach it.

- a) Holding the switch with both hands, position the two, rear rack-mount brackets on the switch between the rack or cabinet posts that do not have slider rails attached to them (see the figure).

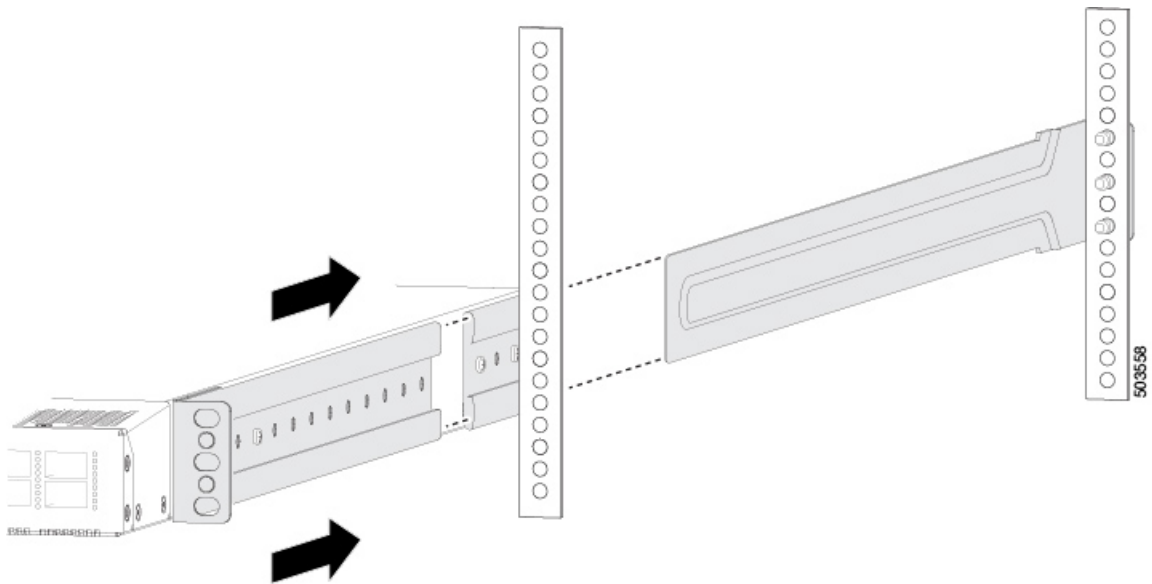

- b) Align the two rear rack-mount guides on either side of the switch with the slider rails installed in the rack. Slide the rack-mount guides onto the slider rails, and then gently slide the switch all the way into the rack until the front rack-mount brackets come in contact with two rack or cabinet posts.
- c) Holding the chassis level, insert screws (12-24 or 10-32, depending on the rack type) in each of the two front rack-mount brackets (using a total of six screws) and into the cage nuts or threaded holes in the vertical rack-mounting rails (see the figure).

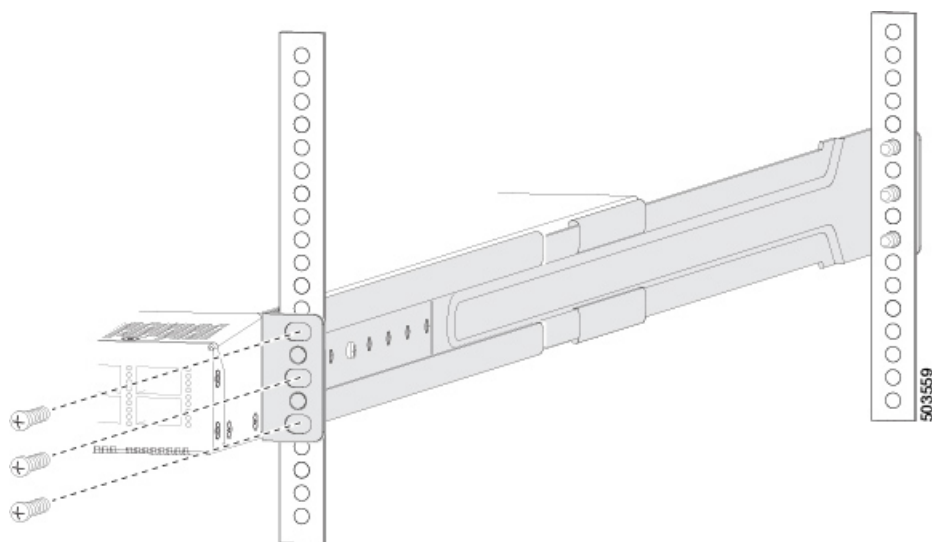

d) Tighten the 10-32 screws to 20 in-lb (2.26 Nm) or tighten the 12-24 screws to 30 in-lb (3.39 Nm).

Step 5 If you attached a grounding wire to the chassis grounding pad, connect the other end of the wire to the facility ground.

Installing the Airflow Sleeve (N9K-AIRFLOW-SLV)

Install the airflow sleeve (N9K-AIRFLOW-SLV) to allow proper airflow, so that the switch is properly cooled. This airflow sleeve is only compatible with rack mount kit (N3K-C3064-ACC-KIT).

Table 3: Airflow Sleeve (N9K-AIRFLOW-SLV) Minimum and Maximum Rack Rail Depth.

Chassis	Minimum Rack Depth	Maximum Rack Depth
N9K-C92348GC-X	636.49 mm	748.25 mm
N9K-C9316D-GX	824.80 mm	916.60 mm
N9K-C9332C	794.20 mm	898.70 mm
N9K-C9332D-GX2B	824.00 mm	915.80 mm
N9K-C9336C-FX2	802.39 mm	903.98 mm
N9K-C9336C-FX2-E	806.90 mm	898.70 mm
N9336C-SE1	806.90 mm	898.70 mm
N9K-C9348GC-FXP	672.49 mm	764.29 mm
N9K-C93108TC-FX	781.29 mm	873.09 mm
N9K-C93108TC-FX3P	672.49 mm	769.69 mm
N9K-C93180YC-FX	781.29 mm	873.09 mm

Chassis	Minimum Rack Depth	Maximum Rack Depth
N9K-C93180YC-FX3	672.49 mm	784.25 mm
N9K-C93180YC-FX3S	672.49 mm	784.25 mm
N9K-C93600CD-GX	824.80 mm	916.60 mm



Note You supply the screws to mount the airflow sleeve.

Before you begin

- Verify that your shipment is complete.
- Install your rack in a secure location.

Procedure

Insert the airflow sleeve into the rack and attach it:

- Holding the airflow sleeve (N9K-AIRFLOW-SLV) with both hands, position it in front of the fan side of the chassis.
- Holding the airflow sleeve level, insert screws (12-24 or 10-32, depending on the rack type) in each of the two front rack-mount flanges (using a total of two screws) and into the cage nuts or threaded holes in the vertical rack-mounting rails (see figure 1).

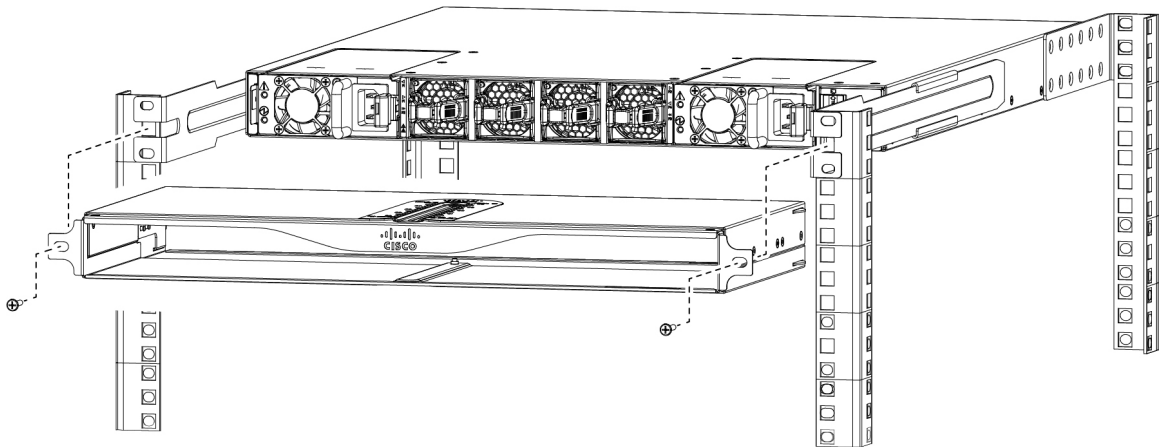

- Tighten the 10-32 screws to 20 in-lb (2.26 N·m) or tighten the 12-24 screws to 30 in-lb (3.39 N·m) of torque.

Grounding the Chassis

The switch chassis is automatically grounded when you properly install the switch in a grounded rack with metal-to-metal connections between the switch and rack.



Note Provide an electrical conducting path between the product chassis and the metal surface of the enclosure or rack in which it is mounted or to a grounding conductor. To ensure electrical continuity, use thread-forming type mounting screws that remove any paint or non-conductive coatings and establish a metal-to-metal contact. Remove any paint or other non-conductive coatings on the surfaces between the mounting hardware and the enclosure or rack. Clean the surfaces and apply an antioxidant before installation.

Ground the chassis, which is required if the rack is not grounded. Attach a customer-supplied grounding cable. Attach the cable to the chassis grounding pad and the facility ground.



Warning Statement 1024—Ground Conductor

This equipment must be grounded. To reduce the risk of electric shock, never defeat the ground conductor or operate the equipment in the absence of a suitably installed ground conductor. Contact the appropriate electrical inspection authority or an electrician if you are uncertain that suitable grounding is available.



Warning Statement 1046—Installing or Replacing the Unit

To reduce risk of electric shock, when installing or replacing the unit, the ground connection must always be made first and disconnected last.

Before you begin

Before you can ground the chassis, connect to earth ground of the data center building.

Procedure

Step 1 Use a wire-stripping tool to remove approximately 0.75 inch (19 mm) of the covering from the end of the grounding wire. We recommend 6-AWG wire for the U.S. installations.

Step 2 Insert the stripped end of the grounding wire into the open end of the grounding lug. Use a crimping tool to crimp the lug to the wire, see the figure. Verify that the ground wire is securely attached to the grounding lug by attempting to pull the wire out of the crimped lug (tug test).

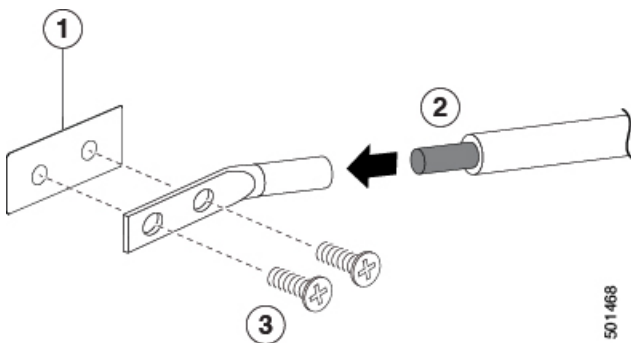

1	Chassis grounding pad	3	2 M4 screws are used to secure the grounding lug to the chassis
2	Grounding cable, with 0.75 in. (19 mm) of insulation that is stripped from one end, which is inserted into the grounding lug and crimped in place		

Step 3 Secure the grounding lug to the chassis grounding pad with two M4 screws, see figure 1. Tighten the screws to 11 to 15 in-lb (1.24 to 1.69 Nm) of torque.

Step 4 Prepare the other end of the grounding wire and connect it to the facility ground.

Starting the Switch

Start the switch by connecting it to its dedicated power source. If you need $n+n$ redundancy, connect each power supply in a switch to a different power source.



Note This equipment is designed to boot up in less than 30 minutes, dependent on its neighboring devices being fully up and running.

Before you begin

- The switch must be installed and secured to a rack or cabinet.
- The switch must be adequately grounded.
- The rack must be close enough to the dedicated power source so that you can connect the switch to the power source by using the designated power cables.
- You have the designated power cables for the power supplies that you are connecting to the dedicated power sources.



Note Depending on the outlet receptacle on your AC power distribution unit, you might need an optional jumper power cord to connect the switch to your outlet receptacle.

- The switch is not connected to the network (this includes any management or interface connections).
- The fan and power supply modules are fully secured in their chassis slots.

Procedure

Step 1 For any AC power supply, do this:

- a) Using the recommended AC power cable for your country or region, connect one end to the AC power supply.

b) Connect the other end of the power cable to the AC power source.

Step 2 For any HVAC/HVDC power supply, connect it to a power source like this:

- a) Using the recommended high voltage power cable for your country or region, connect the Anderson Power Saf-D-Grid connector on the power cable to the power receptacle on the power supply. Make sure that the connector clicks when fully pushed into the receptacle.
- b) Connect the other end of the power cable to a power source.
- When connecting to an HVAC power source, insert the plug in a receptacle for the HVAC power source.
 - When connecting to an HVDC power source, do this:
 1. Verify that the power is turned off at a circuit breaker for the power source terminals.
 2. Remove the nuts from each of the terminal posts for the power supply.
 3. Place the power cable negative-wire terminal ring on the negative terminal for the power source and secure them with a terminal nut.
 4. Place the power cable positive-wire terminal ring on the positive terminal for the power source and secure them with a terminal nut.
 5. Place the power cable ground-wire terminal ring on the ground terminal for the power source and secure them with a terminal nut.
 6. If there is a safety cover for the power source terminals, place and secure it over the terminals to avoid an electrical shock hazard.
 7. Turn on the power at the power source circuit breaker.

Step 3 For any DC power supply, do this:

- a) Turn off the circuit breaker for the power source to avoid an electrical shock hazard.
- b) Verify that the power cable wires from the power source are connected to a connector block.
- c) Insert the connector block into the receptacle on the power supply. Make sure that the connector block clicks when fully inserted in the receptacle and does not pull out.
- d) If there is a safety cover for the terminals, place and secure it over the terminals to avoid an electrical shock hazard.
- e) Turn on the power at the circuit breaker for the DC power source.

Step 4 Verify that the power supply LED is on and green.

Step 5 Listen for the fans; they should begin operating when the power supply is powered.

Step 6 After the switch boots, verify that these LEDs are lit:

- On the fan modules, the Status (STA or STS) LED is green.
If a fan module Status LED is not green, try reinstalling the fan module.
- After initialization, the switch chassis Status (labeled as STA or STS) LED is green.

Step 7 Verify that the system software has booted and the switch has initialized without error messages.

A setup utility automatically launches the first time that you access the switch and guides you through the basic configuration. For instructions on how to configure the switch and check module connectivity, see the appropriate Cisco Nexus 9000 Series configuration guide.



CHAPTER 4

Connecting the Switch to the Network

- [Overview of Network Connections, on page 27](#)
- [Connecting a Console to the Switch, on page 27](#)
- [Creating the Initial Switch Configuration, on page 29](#)
- [Setting Up the Management Interface, on page 30](#)
- [Connecting Interface Ports to Other Devices, on page 30](#)

Overview of Network Connections

After you install the switch in a rack and power it up, make these network connections:

- **Console connection**—This is a direct local management connection that you use to initially configure the switch. Make this connection **first** to initially configure the switch and determine its IP address, which is needed for the other connections.
- **Management connection**—After you complete the initial configuration using a console, make this connection to manage all future switch configurations.
- **Uplink and downlink interface connections**—These are connections to hosts and servers in the network.

Each of these connection types is explained in one of these sections.



Note When running cables in overhead or subfloor cable trays, we strongly recommend that you locate power cables and other potential noise sources as far away as practical from network cabling that terminates on Cisco equipment. In situations where long parallel cable runs cannot be separated by at least 3.3 feet (1 meter), we recommend that you shield any potential noise sources by housing them in a grounded metallic conduit.

Connecting a Console to the Switch

Before you create a network management connection for the switch or connect the switch to the network, create a local management connection through a console terminal. Then configure an IP address for the switch. Use the console to perform these functions, each of which can be performed through the management interface after you make that connection.

- Configure the switch using the command-line interface (CLI).

- Monitor network statistics and errors.
- Configure Simple Network Management Protocol (SNMP) agent parameters.
- Download software updates.

Make this local management connection between the asynchronous serial port on a supervisor module and a console device capable of asynchronous transmission. Typically, you use a computer terminal as the console device. On the supervisor modules, use the console serial port.



Note Before you can connect the console port to a computer terminal, make sure that the computer terminal supports VT100 terminal emulation. The terminal emulation software makes communication between the switch and the computer possible during setup and configuration.

Before you begin

- The switch must be fully installed in its rack, connected to a power source, and grounded.
- The necessary cabling for the console, management, and network connections must be available.
 - An RJ-45 rollover cable provided in the switch accessory kit.
 - Network cabling is routed to the location of the installed switch.

Procedure

- Step 1** Configure the console device to match these default port characteristics:
- 9600 baud
 - 8 data bits
 - 1 stop bit
 - No parity
- Step 2** Connect an RJ-45 rollover cable to the console port on the switch.
Find this cable in the accessory kit.
- Step 3** Route the RJ-45 rollover cable to the console or a modem.
- Step 4** Connect the other end of the RJ-45 rollover cable to the console or to a modem.
-

What to do next

You are ready to create the initial switch configuration. See [Creating the Initial Switch Configuration, on page 29](#).

Creating the Initial Switch Configuration

Before you begin

- A console device must be connected with the switch.
- The switch must be connected to a power source.
- Determine the IP address and the netmask that is needed for the Management (Mgmt0) interface.

Procedure

Step 1 Power up the switch by connecting each installed power supply to an AC circuit.

If you are using the input-source ($n+n$) power mode, connect half of the power supplies to one AC circuit. Connect the other half of the power supplies to another AC circuit.

The Input and Output LEDs on each power supply light up (green) when the power supply units are sending power to the switch. The software asks you to specify a password to use with the switch.

Step 2 Enter a new password for this switch.

The software checks the security strength of your password. It rejects your password if it does not meet these guidelines:

- At least eight characters.
- Minimizes or avoids the use of consecutive characters (such as "abcd").
- Minimizes or avoids repeating characters (such as "aaabbb").
- Does not contain recognizable words from the dictionary.
- Does not contain proper names.
- Contains both uppercase and lowercase characters.
- Contains numbers and letters.

Note Clear text passwords cannot include the dollar sign (\$) special character.

Tip If a password is trivial (such as a short, easy-to-decipher password), the software will reject your password configuration. Configure a strong password as explained in this step. Passwords are case-sensitive.

When you enter a strong password, the software asks you to confirm the password.

Step 3 Enter the same password again.

If you enter the same password, the software accepts the password and begins asking a series of configuration questions.

Step 4 Until you are asked for an IP address, enter the default configuration for each question.

Repeat this step for each question until you are asked for the Mgmt0 IPv4 address.

Step 5 Enter the IP address for the management interface.

The software asks for the Mgmt0 IPv4 netmask.

Step 6 Enter a network mask for the management interface.
The software asks if you need to edit the configuration.

Step 7 Enter **no**, to not edit the configuration.
The software asks if you need to save the configuration.

Step 8 Enter **yes** to save the configuration.

What to do next

Set up the management interface for each supervisor module on the switch.

Setting Up the Management Interface

The RJ-45 and/or SFP management ports provide out-of-band management, which enables you to use the command-line interface (CLI) to manage the switch by its IP address. Use one of these ports depending on the cable and connectors that you are using to connect the management interface to the network.

Before you begin

- The switch must be powered on.
- The switch must be initially configured using a console.

Procedure

Step 1 Connect the management cable into the management port on the switch. For shorter connections, use a cable with RJ-45 connectors. For longer connections, use an optical cable with SFP transceivers (LH or SX type).

Note Use only one of these management ports—the switch does not support the use of both management ports.

Step 2 Connect the other end of the cable to a 10/100/1000 or SFP port on a network device.

Connecting Interface Ports to Other Devices

After you perform the initial configuration for the switch and create a management connection, you are ready to connect the interface ports on the switch to other devices. Depending on the types of interface ports on the switch, use interface cables with QSFP28, QSFP+, SFP+, SFP transceivers, or RJ-45 connectors to connect the switch to other devices.



Note When using SFP+ or SFP transceivers in a QSFP+ or QSFP28 uplink port, install a QSFP-to-SFP adapter, such as the CVR-QSFP-SFP10G adapter, in the QSFP port and then install the SFP+ or SFP transceiver. The switch automatically sets the port speed to the speed of the installed transceiver.

If the transceivers that you are using can be separated from their optical cables, install the transceivers without their cables before inserting the cables into the transceivers. This helps to prolong the life of both the transceiver and cables. When removing transceivers from the switch, remove the optical cable first and then remove the transceiver.

To determine which transceivers, adapters, and cables are supported by this switch, see the [Cisco Transceiver Modules Compatibility](#) Information document.



CHAPTER 5

Replacing Components

- [Replacing a Fan Module, on page 33](#)
- [Replacing a Power Supply Module, on page 34](#)

Replacing a Fan Module

You can replace a fan module while the switch is operating, as long as you perform the replacement within one minute. If you cannot perform the replacement within one minute, leave the original fan module in the chassis to maintain the designed airflow until you have the replacement fan module on hand and can perform the replacement.



Caution If you are replacing a module during operations, verify the replacement fan module has the correct direction of airflow. This means that it has the **same airflow direction** as the other modules in the chassis. Also, verify that the airflow direction takes in air from a cold aisle and exhausts air to a hot aisle. Otherwise, the switch can overheat and shutdown.

If you are changing the airflow direction of all the modules in the chassis, shutdown the switch before replacing all the fan and power supply modules with modules using the other airflow direction. During operations, all of the modules must have the same direction of airflow.

Removing a Fan Module



Caution The fans might still be turning when you remove the fan assembly from the chassis. Keep fingers, screwdrivers, and other objects away from the openings in the fan assembly's housing.

Procedure

-
- Step 1** On the fan module that you are removing, press the two sides of the fan module handle together, and pull on the handles enough to unseat it from its connectors.
- Step 2** Holding the handle, pull the module out of the chassis.

Caution Do not touch the electrical connectors on the back side of the module and prevent anything else from coming into contact with and damaging the connectors.

Installing a Fan Module

Before you begin

- A fan slot must be open and ready for the new fan module to be installed.
- If the switch is operating, you must have a new fan module on hand and ready to install within one minute of removing the original fan module.
- The new fan module must have the **same airflow direction** as the other fan and power supply modules installed in the switch.

Procedure

- Step 1** Holding the fan module by its handle, align the back of the fan module (the side with the electrical connectors) to the open fan slot in the chassis.
- Step 2** Slide the fan module into the slot until it clicks in place.
- Step 3** Verify that the Status (STS) LED turns on and becomes green.
-

Replacing a Power Supply Module

The switch requires two power supplies for redundancy. With one power supply providing the necessary power for operations, replace the other power supply during operations as long as the new power supply has the same airflow direction as the other modules in the chassis.

Replace a power supply with another supported power supply that has the same power source type as the other installed power supply. Additionally, the airflow direction of the power supply must match or conform to the airflow direction of the installed fan modules. For the airflow direction used by the switch, see the coloring of the fan modules.

Removing an AC Power Supply

To remove an AC power supply, disconnect the power cable and remove the module from the chassis.

Before you begin

- To replace a power supply during operations, you must have a functioning power supply providing power to the switch while you replace the other power supply. If there is only one power supply installed in the switch and you need to replace it, install the new power supply in the open slot and power it up before removing the original power supply.

- Ensure that the chassis is grounded. For grounding instructions, see [Grounding the Chassis, on page 23](#).

Procedure

-
- Step 1** Disconnect the power cord from the power receptacle on the power supply to be removed. Verify that the LED turns off.
- Note** The LED might be on and amber colored. This indicates that the input power has been disconnected.
- Step 2** Remove the power supply from the chassis by pushing and holding its thumb latch to the left and pulling the power supply part way out of the chassis.
- Step 3** Place your other hand under the power supply to support it while you slide it out of the chassis. Either place the power supply on an antistatic surface or pack it in its packing materials.
-

What to do next

You are ready to install the replacement power supply.

Removing an HVAC/HVDC Power Supply

You can remove one power supply while the other one provides power to the switch.

To disconnect the power supply from its power cables, shut off the power from the power source and disconnect the connector for the power cables.

Procedure

-
- Step 1** Turn off the circuit breaker for the power feed to the power supply that you are replacing. Verify that the LEDs turn off on the power supply that you are removing.
- Step 2** Remove the power cable from the power supply by pressing the tab on the top of the Anderson Power SAF-D-Grid connector and pull the cable and connector out of the power supply.
- Step 3** Grasp the power supply handle while pressing the release latch towards the power supply handle.
- Step 4** Place your other hand under the power supply to support it while you slide it out of the chassis.
- Caution** Do not touch the electrical connectors on the back side of the module. Prevent anything else from coming into contact with or damaging the connectors.
-

What to do next

You are ready to install an HVAC/HVDC power supply in the open slot.

Removing a DC Power Supply

You can remove one power supply while the other one provides power to the switch.

To disconnect the power supply from its power cables, shut off the power from the power source and disconnect the connector for the power cables.

Procedure

-
- Step 1** Turn off the circuit breaker for the power feed to the power supply that you are replacing. Verify that the LEDs turn off on the power supply that you are removing.
- Step 2** Remove the power cable from the power supply. Do this:
- Step 3** Grasp the power supply handle while pressing the release latch towards the power supply handle.
- Step 4** Pull the power supply out of the bay.
-

What to do next

You are ready to install a DC power supply in the open slot.

Installing an AC Power Supply

You can replace one power supply while the other one provides power to the switch.

Before you begin

- The power supply that you are installing must be capable of using the same airflow direction as the fan trays installed in the same switch. It must use the same type of power source as the other power supply installed in the same switch. (Do not mix AC and DC power supplies in the same switch.)



Note If the power supply that you are replacing has a different color handle than the replacement power supply, verify that it has or will have the same airflow direction as the other modules in the switch.

- An AC power source must be within reach of the power cable that will be used with the replacement power supply. If you are using $n+n$ power redundancy, there must be a separate power source for each power supply installed in the chassis. Otherwise, only one power source is required.
- There must be an earth-ground connection to the chassis that you are installing the replacement module. Typically, the chassis is grounded by its metal-to-metal connection with a grounded rack. If you need to ground the chassis, see [Grounding the Chassis, on page 23](#).

Procedure

-
- Step 1** Holding the replacement power supply with one hand underneath the module and the other hand holding the handle, turn the power supply so that its release latch is on the side. Align the back end of the power supply (the end with the electrical connections) to the open power supply slot. Carefully slide the power supply all the way into the slot until it clicks into place.
- Note** If the power supply does not fit into the open slot, turn the module over, before sliding it carefully into the open slot.
- Step 2** Test the installation by trying to pull the power supply out of the slot without using the release latch. If the power supply does not move out of place, it is secured in the slot. If the power supply moves, carefully press it all the way into the slot until it clicks into place.
- Step 3** Attach the power cable to the electrical inlet on the front of the power supply.
- Step 4** Verify that the other end of the power cable is attached to the appropriate power source for the power supply.
- Note** Depending on the outlet receptacle on your power distribution unit, install the optional jumper cable to connect the switch to your outlet receptacle.
- Step 5** Verify that the power supply is operational by making sure that the power supply LED is green.
-

Installing an HVAC/HVDC Power Supply

You can replace one power supply while the other one provides power to the switch.



-
- Note** If the power supply that you are replacing has a different color handle than the replacement power supply, verify that it has or will have the same airflow direction as the other modules in the switch.
-

Before you begin

- If you are using DC power for the replacement power supply, turn off the circuit breaker for the power feed to the power supply that you are replacing.
- If you are using $n+n$ power redundancy, there must be a separate power source for each power supply installed in the chassis. Power sources must be of the same type—do not mix AC and DC power sources for the same switch. Otherwise, only one power source is required.
- There must be an earth-ground connection to the chassis that you are installing the replacement module. Typically, the chassis is grounded by its metal-to-metal connection to a grounded rack. If you need to ground this chassis by another means, see [Grounding the Chassis, on page 23](#).

Procedure

-
- Step 1** Holding the replacement power supply with one hand underneath the module and the other hand holding the handle, turn the power supply so that its release latch is on the side. Align the back end of the power supply (the end with the electrical connections) to the open power supply slot. Carefully slide the power supply all the way into the slot until it clicks into place.
- Note** If the power supply does not fit into the open slot, turn the module over. Slide it into the open slot.
- Step 2** Test the installation by trying to pull the power supply out of the slot without using the release latch. If the power supply does not move out of place, it is secured in the slot. If the power supply moves, carefully press it all the way into the slot until it clicks into place.
- Step 3** If the DC power cables and a grounding cable are already connected to an electrical connector block, insert the block into the power receptacle on the power supply.
- Step 4** Verify that the other end of the power cable is connected to the appropriate power source for the power supply.
- Step 5** If using a DC power source, turn on the circuit breaker for the DC power source connected to the power supply.
- Step 6** Verify that the power supply is operational by making sure that the power supply LED is green.
-

Installing a DC Power Supply

You can replace one power supply while the other one provides power to the switch.

Before you begin

- The circuit breaker for the DC power source for the power supply must be turned off.
- The power supply that you are installing must be capable of using the same airflow direction as the fan trays installed in the same switch.
- A DC power source must be within reach of the power cable that will be used with the replacement power supply. If you are using $n+n$ power redundancy, there must be a separate power source for each power supply installed in the chassis. Otherwise, only one power source is required.
- There must be an earth-ground connection to the chassis that you are installing the replacement module. Typically, the chassis is grounded by its metal-to-metal connection to a grounded rack. If you need to ground this chassis by another means, see [Grounding the Chassis, on page 23](#).
- We recommend 8-AWG wire for DC installation in the U.S.
- All DC power supplies have reverse polarity protection. When you inadvertently connect the input power (+) to the DC PSU's – terminal and the input power – to the DC PSU's (+) terminal, the PSU will not be damaged and will operate fine after the input power feeds are correctly wired.

Procedure

Step 1 Holding the replacement power supply with one hand underneath the module and the other hand holding the handle, turn the power supply so that its release latch is on the side. Align the back end of the power supply (the end with the electrical connections) to the open power supply slot. Carefully slide the power supply all the way into the slot until it clicks into place.

Note If the power supply does not fit into the open slot, turn the module over. Carefully slide it into the open slot.

Step 2 If the DC power cables and a grounding cable are already connected to an electrical connector block, insert the block into the power receptacle on the power supply.

Step 3 Turn on the circuit breaker for the DC power source connected to the power supply.

Step 4 Verify that the power supply is operational by making sure that the power supply LED is green.



APPENDIX **A**

Rack Specifications

- [Overview of Racks, on page 41](#)
- [General Requirements for Cabinets and Racks, on page 41](#)
- [Requirements Specific to Standard Open Racks, on page 42](#)
- [Requirements Specific to Perforated Cabinets, on page 42](#)
- [Cable Management Guidelines, on page 42](#)

Overview of Racks

Install the switch in these types of cabinets and racks, assuming an external ambient air temperature range of 0 to 104°F (0 to 40°C):

- Standard perforated cabinets
- Solid-walled cabinets with a roof fan tray (bottom to top cooling)
- Standard open racks



Note If you are using an enclosed cabinet, we recommend one of the thermally validated types, either standard perforated or solid-walled with a fan tray.



Note We do not recommend using racks that have obstructions (such as power strips). The obstructions could impair access to field-replaceable units (FRUs).

General Requirements for Cabinets and Racks

The cabinet or rack must meet these requirements:

- Standard 19-inch (48.3 cm) (two- or four-post EIA cabinet or rack, with mounting rails that conform to English universal hole spacing per section 1 of ANSI/EIA-310-D-1992). For more information, see [Requirements Specific to Perforated Cabinets, on page 42](#).

- The minimum vertical rack space requirement per chassis is:
 - For a one RU (rack unit) switch, 1.75 inches (4.4 cm)
 - For a one and a half RU (rack unit) switch, 2.63 (6.68 cm)
 - For a two RU (rack unit) switch, 3.5 inches (8.8 cm)
 - For a three RU (rack unit) switch, 5.25 inches (13.3 cm)
- The width between the rack-mounting rails must be at least 17.75 inches (45.0 cm) if the rear of the device is not attached to the rack. For four-post EIA racks, this measurement is the distance between the two front rails.

Four-post EIA cabinets (perforated or solid-walled) must meet these requirements:

- The minimum spacing for the bend radius for fiber-optic cables should have the front-mounting rails of the cabinet offset from the front door by a minimum of 3 inches (7.6 cm).
- The distance between the outside face of the front mounting rail and the outside face of the back mounting rail should be 23.0 to 30.0 inches (58.4 to 76.2 cm) to allow for rear-bracket installation.

Requirements Specific to Standard Open Racks

If you are mounting the chassis in an open rack (no side panels or doors), ensure that the rack meets these requirements:

- The minimum vertical rack space per chassis must be equal to the rack unit (RU) of the chassis. One rack unit is equal to 1.75 inches (4.4 cm).
- The distance between the chassis air vents and any walls should be 2.5 inches (6.4 cm).

Requirements Specific to Perforated Cabinets

A perforated cabinet has perforations in its front and rear doors and side walls. Perforated cabinets must meet these requirements:

- The front and rear doors must have at least a 60 percent open area perforation pattern, with at least 15 square inches (96.8 square cm) of open area per rack unit of door height.
- The roof should be perforated with at least a 20 percent open area.
- The cabinet floor should be open or perforated to enhance cooling.

The Cisco R Series rack conforms to these requirements.

Cable Management Guidelines

To help with cable management, allow additional space in the rack above and below the chassis to make it easier to route all of the fiber optic or copper cables through the rack.



APPENDIX **B**

System Specifications

- [Environmental Specifications, on page 43](#)
- [Switch Dimensions, on page 43](#)
- [Switch and Module Weights and Quantities, on page 44](#)
- [Transceiver and Cable Specifications, on page 44](#)
- [Switch Power Input Requirements, on page 44](#)
- [Power Specifications, on page 45](#)
- [Power Cable Specifications, on page 46](#)
- [Regulatory Standards Compliance Specifications, on page 48](#)

Environmental Specifications

Environment		Specification
Temperature	Ambient operating temperature	32 to 104°F (0 to 40°C)
	Ambient nonoperating	−40 to 158°F (−40 to 70°C)
Relative humidity	Nonoperating	5 to 95%
	Operating	5 to 90%
Altitude	Operating	0 to 13,123 feet (0 to 4,000 meters)

Switch Dimensions

Switch	Width	Depth	Height
Cisco Nexus 93180YC-FX3S	17.3 inches (43.9 cm)	19.5 inches (49.6 cm)	1.72 inches (4.4 cm) (1 RU)

Switch and Module Weights and Quantities

Component	Weight per Unit	Quantity
Cisco Nexus 93180YC-FX3S Chassis (N9K-C93180YC-FX3S)	21 lb (9.52 kg)	1
Fan Module	—	4
– Port-side exhaust (blue) (NXA-FAN-35CFM-PE)	0.26 lb (0.12 kg)	
– Port-side intake (burgundy) (NXA-FAN-35CFM-PI)		
Power Supply module	—	2 (1 for operations and 1 for redundancy)
– 650-W AC port-side exhaust (blue) (NXA-PAC-650W-PE)	2.42 lb (1.1 kg)	
– 650-W AC port-side intake (burgundy) (NXA-PAC-650W-PI)	2.42 lb (1.1 kg)	
– 1200-W HVAC/HVDC dual-direction (white) (N9K-PUV-1200W)		
– 930-W DC port-side exhaust (blue) (NXA-PDC-930W-PE)		
– 930-W DC port-side intake (burgundy) (NXA-PDC-930W-PI)		

Transceiver and Cable Specifications

To see the transceiver specifications and installation information, see <https://www.cisco.com/c/en/us/support/interfaces-modules/transceiver-modules/products-device-support-tables-list.html>.

Switch Power Input Requirements

This table lists the typical amount of power that the switch consumes. It also lists the maximum amount of power that you must provision for the switch and power supply for peak conditions.



Note Some power supplies have capabilities that are greater than the maximum power requirements for a switch. To determine the power consumption characteristics for the switch, use the typical and maximum requirements that are listed here.

Switch	Typical Power Consumption (AC or DC)	Maximum Power Consumption (AC or DC)	Heat Dissipation Requirement
Cisco Nexus 93180YC-FX3S	375	600 W	2047.285 BTUs per hour

Power Specifications

Power specifications include the specifications for each type of power supply module.

650-W AC Power Supply Specifications

These specifications apply to the following power supplies:

- NXA-PAC-650W-PE
- NXA-PAC-650W-PI

Characteristic	Specification
AC input voltage	Nominal range: 100 and 240 VAC (Range: 90-132 VAC, 180-264 VAC)
AC input frequency	Nominal range: 50 to 60 Hz (Range: 47-63 Hz)
Maximum AC input current	7.6 A at 90 - 132 VAC 3.65 A at 180 - 264 VAC
Maximum input volt-amperes	760 VA at 100 VAC
Maximum output power per power supply	650 W
Maximum inrush current	11 A (sub-cycle duration)
Maximum hold-up time	12 ms at 650 W
Power supply output voltage	12 VDC
Power supply standby voltage	12 VDC
Efficiency rating	Climate Savers Platinum Efficiency (80Plus Platinum certified)
Form factor	RSP1

1200-W HVAC/HVDC Power Supply Specifications

These specifications apply to the N9K-PUV-1200W power supplies.

Characteristic	Specification
Input voltage <ul style="list-style-type: none"> • AC (for 1230 W output) • DC (for 1230 W output) 	<ul style="list-style-type: none"> • Nominal range: 100-240 Vac (Range: 90-264 Vac) • Nominal range: 200-277 Vac (Range: 180-305 Vac) • Nominal range: 240-380 Vdc (Range: 1204-400 Vdc)
AC input frequency	Nominal: 50 to 60 Hz (Range: 47-63 Hz)

Characteristic	Specification
Maximum AC input current	10 A at 100 Vac
Maximum inrush current	35 A (cold turn on); 70 A (hot turn on)
Maximum output Watts <ul style="list-style-type: none"> • For 200 to 277 VAC • For 192 to 400 VDC 	Per power supply <ul style="list-style-type: none"> • 1230 W • 1230 W
Power supply output voltage <ul style="list-style-type: none"> • For 200 to 277 VAC • For 192 to 400 VDC 	Per power supply <ul style="list-style-type: none"> • 12 Vdc at 100 A • 12 Vdc at 100 A
Power supply standby voltage	12 V at 2.5 A
Efficiency rating	Climate Savers Platinum Efficiency (80Plus Platinum certified)
Form factor	RSP1

930-W DC Power Supply Specifications

These specifications apply to the NXA-PDC-930W power supplies.

Characteristic	Specification
DC input voltage range	Nominal range: -48 to -72 Vdc nominal (Range: -40 to -60 Vdc)
Maximum DC input current	23 A at -48 Vdc
Maximum output power per power supply	930 W
Maximum inrush current	35 A (sub-cycle duration)
Maximum hold-up time	8 ms at 930 W
Power supply output voltage	12 Vdc
Power supply standby voltage	12 Vdc
Efficiency rating	Greater than 92% at 50% load
Form factor	RSP1

Power Cable Specifications

These sections show the power cables that you can order and use with this switch.

Power Cable Specifications for AC Power Supplies

Power Type	Power Cord Part Number	Cord Set Description
	CAB-C13-C14-2M	Power Cord Jumper, C13-C14 Connectors, 6.6 feet (2.0 m)
	CAB-C13-CBN	Cabinet jumper power cord, 250 VAC, 10 A, C14-C13 connectors, 2.3 feet (0.7 m)
Argentina	CAB-250V-10A-AR	250 V, 10 A, 8.2 feet (2.5 m)
Australia	CAB-9K10A-AU	250 VAC, 10 A, 3112 plug, 8.2 feet (2.5 m)
Brazil	CAB-250V-10A-BR	250 V, 10 A, 6.9 feet (2.1 m)
European Union	CAB-9K10A-EU	250 VAC, 10 A, CEE 7/7 plug, 8.2 feet (2.5 m)
India	CAB-IND-10A	10 A, 8.2 feet (2.5 m)
India	CAB-C13-C14-2M-IN	Power Cord Jumper, C13-C14 Connectors, 6.6 feet (2.0 m)
India	CAB-C13-C14-3M-IN	Power Cord Jumper, C13-C14 Connectors, 9.8 feet (3.0 m)
Israel	CAB-250V-10A-IS	250 V, 10 A, 8.2 feet (2.5 m)
Italy	CAB-9K10A-IT	250 VAC, 10 A, CEI 23-16/VII plug, 8.2 feet (2.5 m)
Japan	CAB-C13-C14-2M-JP	Power Cord Jumper, C13-C14 Connectors, 6.6 feet (2.0 m)
North America	CAB-9K12A-NA	125 VAC, 13 A, NEMA 5-15 plug, 8.2 feet (2.5 m)
North America	CAB-AC-L620-C13	NEMA L6-20-C13, 6.6 feet (2.0 m)
North America	CAB-N5K6A-NA	200/240V, 6A, 8.2 feet (2.5 m)
Peoples Republic of China	CAB-250V-10A-CN	250 V, 10 A, 8.2 feet (2.5 m)
South Africa	CAB-250V-10A-ID	250 V, 10 A, 8.2 feet (2.5 m)
Switzerland	CAB-9K10A-SW	250 VAC, 10 A, MP232 plug, 8.2 feet (2.5 m)
United Kingdom	CAB-9K10A-UK	250 VAC, 10 A, BS1363 plug (13 A fuse), 8.2 (2.5 m)
All except Argentina, Brazil, and Japan	NO-POWER-CORD	No power cord included with switch

HVAC/HVDC Power Cables Supported by ACI-Mode and NX-OS Mode Switches

DC Power Cable Specifications

Part ID Number	Description	Photo
NXA-PDC-930W-PE/PI	The 930W DC power supply (NXA-PDC-930W-PE/PI) is shipped with cable CAB-48DC-40A-8AWG.	

Regulatory Standards Compliance Specifications

This table lists the regulatory standards compliance for the switch.

Table 4: Regulatory Standards Compliance: Safety and EMC

Specification	Description
Regulatory compliance	Products should comply with CE Markings according to directives 2004/108/EC and 2006/95/EC.
Safety	<ul style="list-style-type: none"> • CAN/CSA-C22.2 No. 60950-1 Second Edition • CAN/CSA-C22.2 No. 62368-1-19 Third Edition • ANZI/UL 60950-1 Second edition • IEC 62368-1 • EN 62368-1 • AS/NZS 62368-1 • GB4943 • UL 62368-1

Specification	Description
EMC: Emissions	<ul style="list-style-type: none">• 47CFR Part 15 (CFR 47) Class A• AS/NZS CISPR22 Class A• CISPR22 Class A• EN55022 Class A• ICES003 Class A• VCCI Class A• EN61000-3-2• EN61000-3-3• KN22 Class A• CNS13438 Class A
EMC: Immunity	<ul style="list-style-type: none">• EN55024• CISPR24• EN300386• KN 61000-4 series
RoHS	The product is RoH-6 compliant with exceptions for leaded-ball grid-array (BGA) balls and lead press-fit connectors.



APPENDIX C

LEDs

- [Switch Chassis LEDs, on page 51](#)
- [Fan Module LEDs, on page 52](#)
- [Power Supply LEDs, on page 52](#)

Switch Chassis LEDs

The BCN, STS, and ENV, LEDs are located on the left side of the front of the switch. The port LEDs appear as triangles pointing up or down to the nearest port.

LED	Color	Status
BCN	Flashing blue	The operator has activated this LED to identify this switch in the chassis.
	Off	This switch is not being identified.
STS	Green	The switch is operational.
	Flashing amber	The switch is booting up.
	Amber	Temperature exceeds the minor alarm threshold.
	Red	Temperature exceeds the major alarm threshold.
	Off	The switch is not receiving power.
ENV	Green	Fans and power supply modules are operational.
	Amber	At least one fan or power supply module is not operating.
(port)	Green	Port admin state is 'Enabled', SFP is present and the interface is connected (that is, cabled, and the link is up).
	Amber	Port admin state is 'Disabled, or the SFP is absent, or both.
	Off	Port admin state is 'Enabled' and SFP is present, but interface is not connected.

LED	Color	Status
(SYNC)	Green	The frequency are synchronized to external interface. The external interface could be GPS, Recovered RX clk).
	Amber	Freerun/Holdover - Time core is in freerun or holdover mode.
	Off	Time core clock synchronization is disabled.
(TIMING)	Green	The time, phase are synchronized to external interface. The external interface could be (GPS, FP).
	Amber	Freerun/Holdover - Time core is in freerun or holdover mode.
	Off	Time core clock synchronization is disabled.
(GNSS)	Green	GPS interface provisioned and ports are turned on. ToD, 1PPS, 10MHz are all valid.
	Off	Either the interface is not provisioned, or the ports are not turned on. ToD, 1PPS, 10MHz are not valid.

Fan Module LEDs

The fan module status LED is located below the air holes on the front of the fan module. Every fan module has an LED.

LED	Color	Status
Status	Green	The fan module is operational.
	Red	The fan module is not operational (fan is probably not functional).
	Off	Fan module is not receiving power.

Power Supply LEDs

The power supply LEDs are located on the right portion of the power supply. Combinations of states indicated by the **OK** and **Fault** LEDs signify the status for the module as shown in this table.

OK LED	FAIL or FAIL/ID LED	Status
Green	Off	Power supply is on and outputting power to the switch.
Flashing green	Off	Power supply is connected to a power source but not outputting power to the switch. The power supply may not be properly installed in the chassis.
Off	Off	Either all the installed power supplies are not receiving power or an uninstalled power supply is not receiving power.

OK LED	FAIL or FAIL/ID LED	Status
Off	Flashing amber	Power supply is operating but a warning condition has occurred—possibly one of these conditions: <ul style="list-style-type: none"> • High temperature • High power • Slow power supply fan • Low voltage • Power supply is installed in the chassis but was disconnected from the power source.
Off	Flashing amber (10 seconds) then amber	Power supply is installed without a connection to a power source.
Off	Amber	Power supply failure—possibly one of these conditions: <ul style="list-style-type: none"> • Over voltage • Over current • Over temperature • Power supply fan failure



APPENDIX **D**

Additional Kits

- [Rack Mount Kit NXK-ACC-KIT-1RU](#), on page 55
- [Airflow Sleeve](#), on page 56

Rack Mount Kit NXK-ACC-KIT-1RU

This table lists and illustrates the contents for the 1-RU rack-mount kit (NXK-ACC-KIT-1RU).

Illustration	Description	Quantity
	Rack-mount kit <ul style="list-style-type: none"> • Front brackets (2) • Rear brackets (2) • Slider rails (2) • M4 Phillips pan-head screws (10) 	1
	Ground lug kit <ul style="list-style-type: none"> • Two-hole lug (1) • M4 x 8-mm Phillips pan-head screws (2) 	1
Not applicable	EAC Compliance document	1
Not applicable	Hazardous substances list for customers in China	1

This table lists and illustrates the console cable (CAB-CONSOLE-RJ45) that can be ordered.

Illustration	Description	Quantity
	Console cable with DB-9F and RJ-45F connectors	1

Airflow Sleeve

This table lists and illustrates the airflow sleeve (N9K-AIRFLOW-SLV).

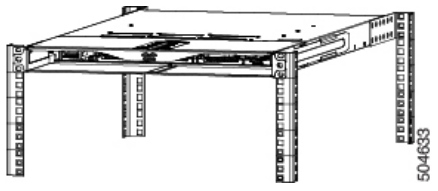
Illustration	Description	Quantity
	Airflow sleeve	1