

# OEM Networking within a Converged Plantwide Ethernet Architecture

---

The prevailing trend in Industrial Automation and Control System (IACS) networking is the convergence of technology, specifically IACS operational technology (OT) with information technology (IT). Converged Plantwide Ethernet (CPwE) helps to enable IACS network technology convergence through the use of standard Ethernet, Internet Protocol (IP), network services, security services and EtherNet/IP connectivity. A converged IACS network technology helps to enable the Industrial Internet of Things (IIoT).

Whether an end user, OEM or system integrator, reliable and secure network infrastructure is critical for IACS design and deployment considerations. IACS applications requirements vary, so scalable and flexible choices in infrastructure devices are key to supporting the type of network and security services that are required for specific IACS applications. The choice of infrastructure devices is driven by the following business and technology aspects:

- Fully managed industrial Ethernet switches (IES) may provide too many reliability and security capabilities for specific IACS application criteria.
- Unmanaged IES reliability and security capabilities may be too limited for specific IACS application criteria.
- Lightly managed IES reliability and security capabilities may provide the right balance of business and technology aspects to meet specific IACS application criteria—for example, segmentation, data prioritization, resiliency and security.

OEM Networking within a Converged Plantwide Ethernet Architecture CRD (Cisco Reference Design), which is documented in the *OEM Networking within a Converged Plantwide Ethernet Architecture Design Guide*, outlines several use cases for designing and deploying lightly managed IES across OEM and plant-wide IACS applications. The CPwE OEM CRD is brought to market through a strategic alliance between Cisco Systems and Rockwell Automation.

Figure 1 CPwE Architectures with Lightly Managed IES at the Edge (highlighted in green)

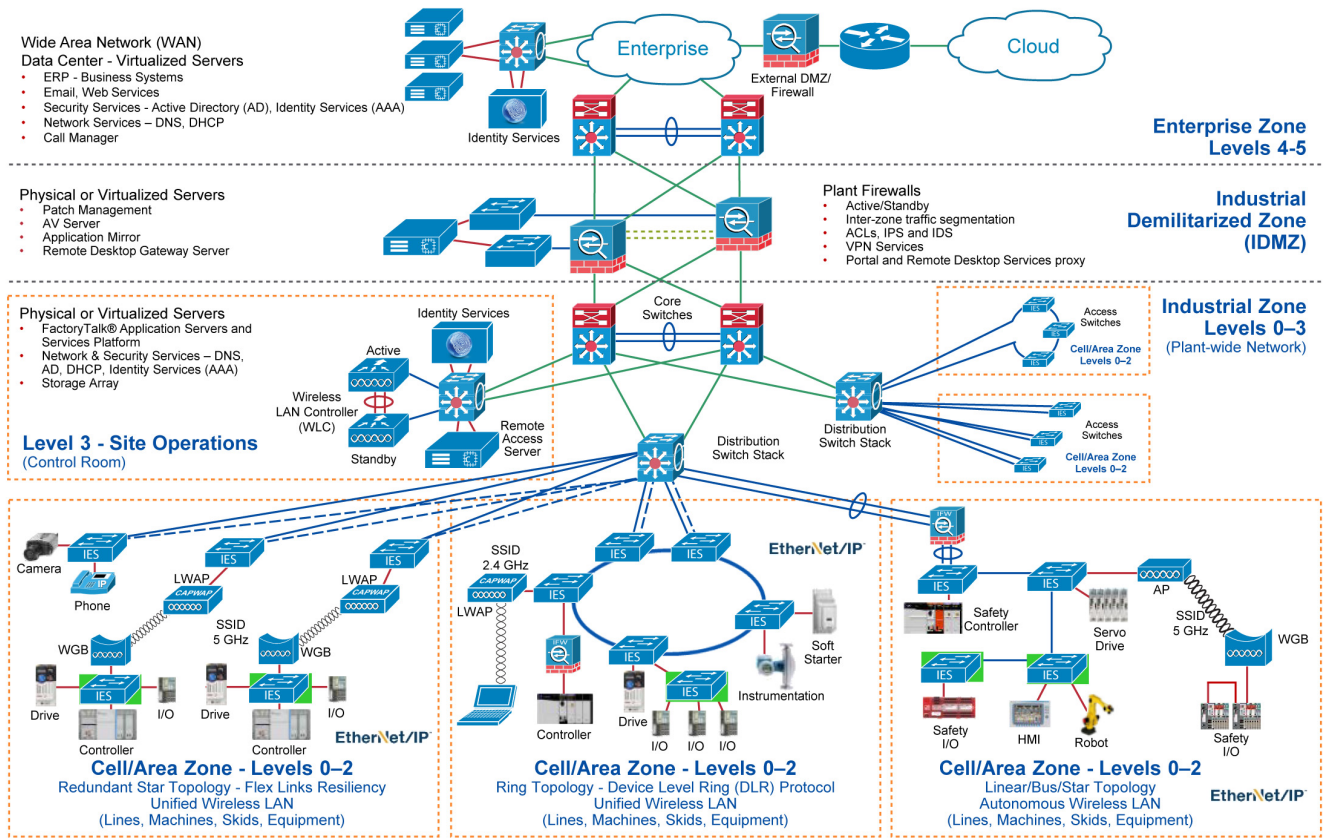

**Note**

This release of the CPwE architecture focuses on EtherNet/IP, which uses the ODVA Common Industrial Protocol (CIP™) and is ready for the Industrial Internet of Things (IIoT). For more information on EtherNet/IP, see [odva.org](http://www.odva.org) at the following URL:

- <http://www.odva.org/Technology-Standards/EtherNet-IP/Overview>

## Convergence-Ready OEM Applications

To help simplify seamless integration into the end user plant-wide network infrastructure, OEMs (skids, machines and equipment) should take into account the following design and deployment considerations when selecting network infrastructure devices such as IES:

- Manageability by an industrial Ethernet protocol that fully uses standard Ethernet and IP (such as EtherNet/IP) as the multi-discipline IIoT technology:
  - Common network infrastructure devices—optimized asset utilization
  - Scalable and future-ready—better sustainability

- IP addressing schema:
  - Who manages? End User (OT/IT) or OEM?
  - Address range (class), subnet, default gateway (routability)
  - Implementation conventions—static/dynamic, hardware/software configurable, network address translation (NAT) and domain name services (DNS)
- Use of Common Layer 2 and Layer 3 Network Services:
  - Segmentation, data prioritization
  - Topologies—Switch-level, device-level and hybrid
  - Availability—Loop prevention and redundant path topologies with resiliency protocols
- Use of Common Layer 1, Layer 2 and Layer 3 Security Services:
  - Physical access, port security, access control lists and application security (for example, FactoryTalk® Security)
  - Alignment with emerging IACS security standards such as IEC-62443 (formerly ISA 99) and NIST 800-82
- Time Synchronization Services:
  - IEEE 1588 Precision Time Protocol (PTP w/E2E)
  - CIP Sync applications—first fault, SOE and CIP Motion

## CPwE OEM CRD

An IACS is deployed in a wide variety of discrete and process manufacturing industries such as automotive, pharmaceuticals, consumer packaged goods, pulp and paper, oil and gas, mining and energy. IACS applications are made up of multiple control and information disciplines such as continuous process, batch, discrete and hybrid combinations. One of the challenges facing manufacturers and OEMs is the industrial hardening of standard Ethernet and IP-converged IACS networking technologies to take advantage of the business benefits associated with the IIoT.

CPwE is the underlying architecture that provides standard network and security services for control and information disciplines, devices and equipment found in modern IACS applications. The CPwE architectures (Figure 1), through testing and validation by Cisco and Rockwell Automation, provide design and implementation guidance, test results and documented configuration settings that can help to achieve the real-time communication, reliability, scalability, security and resiliency requirements of modern IACS applications for manufacturers and OEMs.

The *OEM Networking within a Converged Plantwide Ethernet Architecture Design Guide* outlines the concepts, requirements and technology solutions for application use cases that were tested and documented by Cisco and Rockwell Automation to help support the application of lightly managed IES within plant-wide deployments of EtherNet/IP. The following is a summary of the CPwE OEM CRD:

- Plant-wide Zoning Overview:
  - Cell/Area Zone
  - OEM Sub-zoning
- Capability overview of lightly managed IES:
  - Allen-Bradley® Stratix® 2500
  - Cisco IE 1000

- Design and deployment considerations for lightly managed IES deployments:
  - Stand-alone lightly managed IES
  - Aggregated by fully managed IES
  - Aggregated by fully managed IES with NAT, segmentation and resiliency
- Application use cases (Figure 2):
  - Lightly managed IES for OEM applications (skids, machines, equipment)
  - Lightly managed IES at the edge of the plant-wide EtherNet/IP network

Figure 2 Representative Plant-wide lightly managed IES Deployments

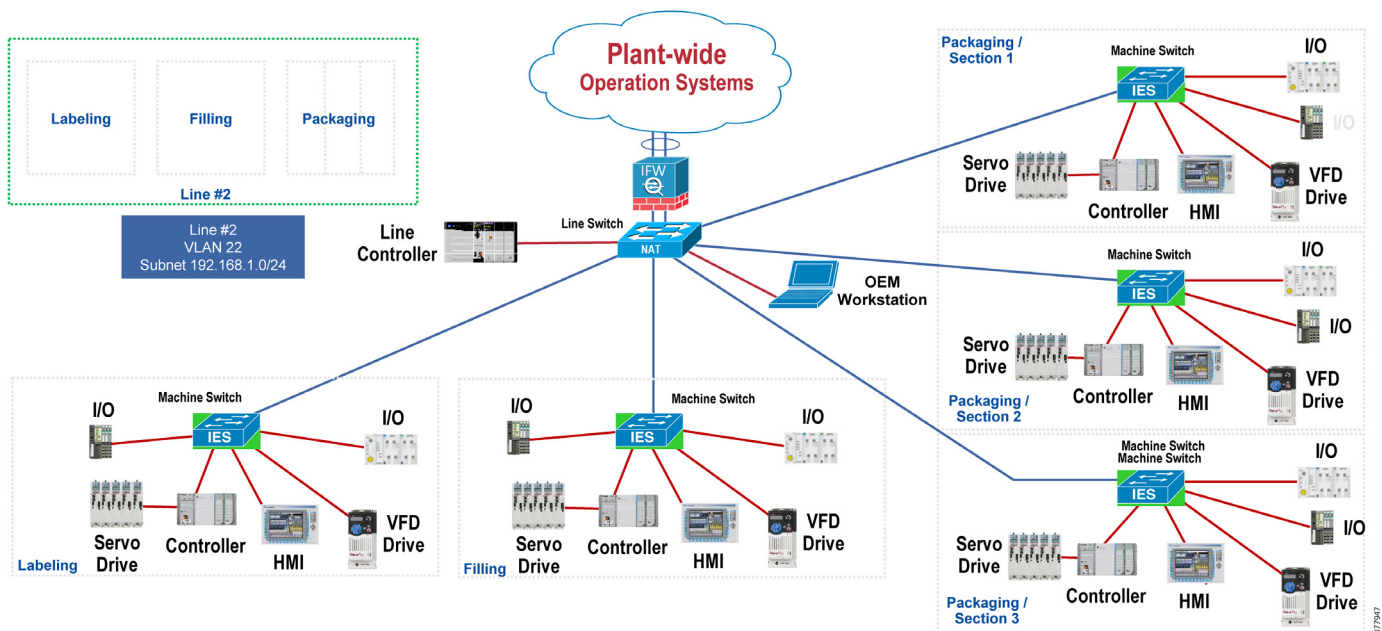

## Summary

CPwE is a collection of tested and validated architectures that are developed by subject matter authorities at Cisco and Rockwell Automation. The testing and validation follow the Cisco Validated Design (CVD) and Cisco Reference Design (CRD) methodologies.

The content of CPwE, which is relevant to both OT and IT disciplines, consists of documented architectures, best practices, guidance and configuration settings to help manufacturers and OEMs with design and deployment of a scalable, reliable, secure and future-ready plant-wide industrial network infrastructure. CPwE also helps manufacturers and OEMs achieve the benefits of cost reductions using proven designs that can help lead to quicker deployment and minimize risk in deploying new technology.

The *OEM Networking within a Converged Plantwide Ethernet Architecture Design Guide* outlines several use cases for designing and deploying lightly managed IES, while maintaining CPwE best practices, for OEM applications (skid, machine, equipment) and throughout the Cell/Area Zone within a plant-wide IACS

network infrastructure. The Design Guide highlights the key IACS application requirements, technology, and supporting design considerations to help with the successful design and deployment of these specific use cases within the framework of CPwE.

More information on CPwE Design and Implementation Guides can be found at the following URLs:

- Rockwell Automation site:
  - <http://www.rockwellautomation.com/global/products-technologies/network-technology/architectures.page?>
- Cisco site:
  - [http://www.cisco.com/c/en/us/solutions/enterprise/design-zone-manufacturing/landing\\_ettf.html](http://www.cisco.com/c/en/us/solutions/enterprise/design-zone-manufacturing/landing_ettf.html)

Cisco is the worldwide leader in networking that transforms how people connect, communicate and collaborate. Information about Cisco can be found at [www.cisco.com](http://www.cisco.com). For ongoing news, please go to <http://newsroom.cisco.com>. Cisco equipment in Europe is supplied by Cisco Systems International BV, a wholly owned subsidiary of Cisco Systems, Inc.

#### [www.cisco.com](http://www.cisco.com)

Americas Headquarters Cisco Systems, Inc. San Jose, CA	Asia Pacific Headquarters Cisco Systems (USA) Pte. Ltd. Singapore	Europe Headquarters Cisco Systems International BV Amsterdam, The Netherlands
--	---	---

Cisco has more than 200 offices worldwide. Addresses, phone numbers, and fax numbers are listed on the Cisco Website at [www.cisco.com/go/offices](http://www.cisco.com/go/offices).

Cisco and the Cisco logo are trademarks or registered trademarks of Cisco and/or its affiliates in the U.S. and other countries. To view a list of Cisco trademarks, go to this URL: [www.cisco.com/go/trademarks](http://www.cisco.com/go/trademarks). Third-party trademarks mentioned are the property of their respective owners. The use of the word partner does not imply a partnership relationship between Cisco and any other company. (1721R)

Rockwell Automation is a leading provider of power, control and information solutions that enable customers to be more productive and the world more sustainable. In support of smart manufacturing concepts, Rockwell Automation helps customers maximize value and prepare for their future by building a Connected Enterprise.

#### [www.rockwellautomation.com](http://www.rockwellautomation.com)

Americas: Rockwell Automation 1201 South Second Street Milwaukee, WI 53204-2496 USA Tel: (1) 414.382.2000 Fax: (1) 414.382.4444	Asia Pacific: Rockwell Automation Level 14, Core F, Cyberport 3 100 Cyberport Road, Hong Kong Tel: (852) 2887 4788 Fax: (852) 2508 1846	Europe/Middle East/Africa: Rockwell Automation NV, Pegasus Park, De Kleetlaan 12a 1831 Diegem, Belgium Tel: (32) 2 663 0600 Fax: (32) 2 663 0640
--	--	---

Allen-Bradley, FactoryTalk, Rockwell Automation and Stratix are trademarks of Rockwell Automation, Inc. Trademarks not belonging to Rockwell Automation are property of their respective companies.

EtherNet/IP and CIP are trademarks of the ODVA.