



Overview

- [Features, on page 1](#)
- [Package Contents, on page 4](#)
- [Serial Number Locations, on page 4](#)
- [Front Panel, on page 6](#)
- [Front Panel LEDs, on page 9](#)
- [Rear Panel, on page 12](#)
- [Rear Panel LEDs, on page 13](#)
- [Power Supply, on page 14](#)
- [Hardware Specifications, on page 15](#)
- [Product ID Numbers, on page 16](#)
- [Power Cord Specifications, on page 16](#)

Features

The Cisco Secure Management Center 1700, 2700, and 4700 management appliances run software that provides extensive intelligence about the users, applications, devices, threats, and vulnerabilities that exist in your network. It also uses this information to analyze your network's vulnerabilities. It then provides tailored recommendations on what security policies to put in place and what security events you should investigate.

The management center appliances support Cisco Secure Threat Defense software. See the [Cisco Firepower Compatibility Guide](#), which provides Cisco Secure software and hardware compatibility, including operating system and hosting environment requirements, for each supported version.

The following figure shows the Secure Management Center 4700.

Figure 1: Cisco Secure Management Center 4700



The following table lists the features of the 1700, 2700, and 4700.

Table 1: 1700, 2700, and 4700 Features

| Feature | 1700 | 2700 | 4700 |
|----------------------------|---|---|---|
| Form factor | 1 RU | | |
| Rack mount | Standard 19-inch (48.3 cm) 4-post EIA rack | | |
| Airflow | Front to rear Cold aisle to hot aisle | | |
| Pullout asset card | Displays the serial number and the MAC address for the two management ports (eth0 and eth1) | | |
| Grounding hole | Two threaded holes for a dual-hole grounding lug Use is optional; the supported AC power supplies have internal grounding, so no additional chassis grounding is required. | | |
| Unit identification button | On the front panel | | |
| Power button | On the rear panel | | |
| Processor | One AMD A7232P 8-core 3.1-GHz processor | One AMD A7282 16-core 2.8-GHz processor | One AMD A7352 24-core 2.3-GHz processor |
| Memory | 32-GB RAM | 64-GB RAM | 128-GB RAM |

| Feature | 1700 | 2700 | 4700 |
|---|--|---|---|
| RDIMMs Internal component only; not field-replaceable | Two 16-GB DDR4-3200-MHz DIMMs | Four 16-GB DDR4-3200-MHz DIMMs | Eight 16-GB DDR4-3200-MHz DIMMs |
| Management ports | Two built-in 10-Gigabit Ethernet RJ45 OCP 3.0 NIC SFP+ ports (eth0 and eth1) Support for 100/1000/10000 Mbps The primary management port is eth0. You can use eth1, eth2, and eth3 as secondary management or event ports. | | |
| USB ports | Two USB 3.0 Type A | | |
| VGA port | One 3-row 15-pin DB-15 connector Enabled by default | | |
| SFP ports | Two fixed SFP+ ports (eth2 and eth3) | | |
| Supported SFP+ ¹ | SFP-10G-SR (10 Gb) SFP-10G-LR (10 Gb) | SFP-10G-SR (10 Gb) SFP-10G-LR (10 Gb) | SFP-10G-SR (10 Gb) SFP-10G-LR (10 Gb) SFP-25G-SR-S (25 Gb) SFP-10/25G-LR-S (25 Gb) SFP-10/25G-CSR-S (25 Gb) |
| Serial console port | RJ-45 serial port running RS-232 (RS-232D TIA-561) | | |
| System power | Two 1050-W AC power supplies Hot-swappable and redundant as 1+1 | | |
| Power consumption | 2626 BTU/hr | | |
| Fans | Eight fans for front-to-rear cooling Internal component only; not field-replaceable | | |
| Storage | Two 1.2-TB 10-K SAS SFF HDDs RAID 1, hot-swappable | Four 600-GB 10-K SAS SFF HDDs RAID 5, hot-swappable | Ten 1.2-TB 10-K SAS SFF HDDs RAID 6, hot-swappable |
| RAID controller | 1 The chassis has a dedicated internal riser for a PCIe-style Cisco modular RAID controller card. Internal component only; not field replaceable. | | |

¹ **Note** Use only SFPs have been qualified for use on the management center. Although non-Cisco SFPs and other Cisco SFPs are allowed, we do not recommend using them because they have not been tested and validated by Cisco. Cisco TAC may refuse support for any interoperability problems that result from using an untested SFP transceiver.

Package Contents

The following figure shows the package contents for the 1700, 2700, and 4700. Note that the contents are subject to change and your exact contents might contain additional or fewer items.

Figure 2: Package Contents

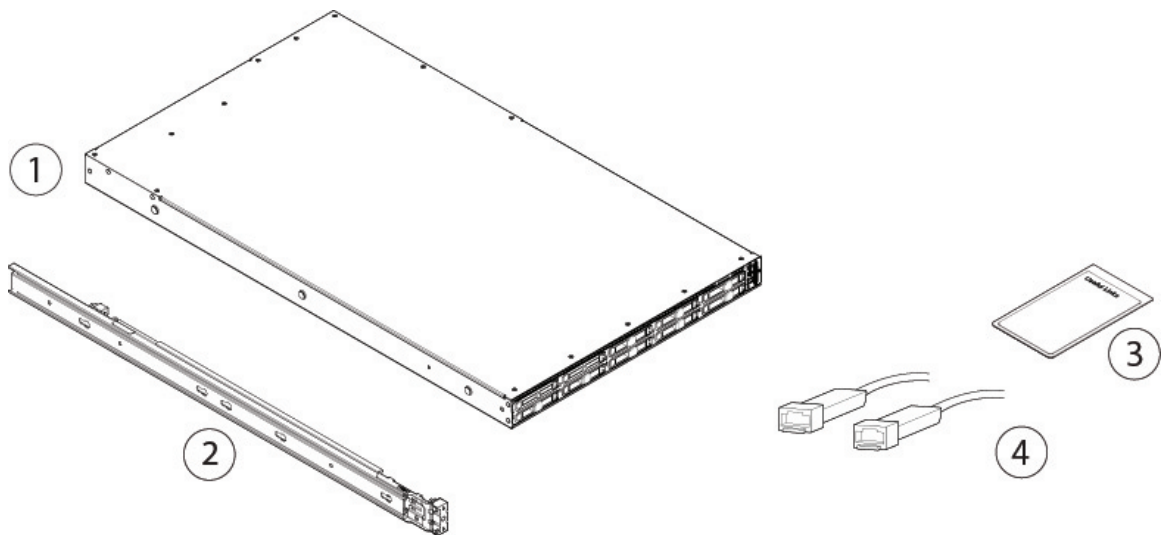

| | | | |
|---|---|---|--|
| 1 | Chassis | 2 | Cisco rail kit (Cisco part number 800-49567-01) |
| 3 | <p><i>Cisco Secure Management Center 1700, 2700, and 4700</i></p> <p>This document contains URLs that point to the hardware installation guide, regulatory compliance and safety information guide, warranty, and licensing pages, and a QR code that points to the management center Documentation Portal.</p> | 4 | <p>Two 10-Gb SFP+ transceivers with cables supported for all models or 25-Gb SFP+ transceivers with cables supported for the 4700</p> <p>Optional for all models; in package if ordered.</p> |

Serial Number Locations

The Serial Number (SN) and the Media Access Control (MAC) address for the 1700, 2700, and 4700 are printed on the top of the pullout asset card located on the front panel as shown in the following figure of the 1700. The PID (Product ID) and VID (Version ID) are printed on the back of the pullout asset card.

Figure 3: Serial Number on Pullout Asset Card

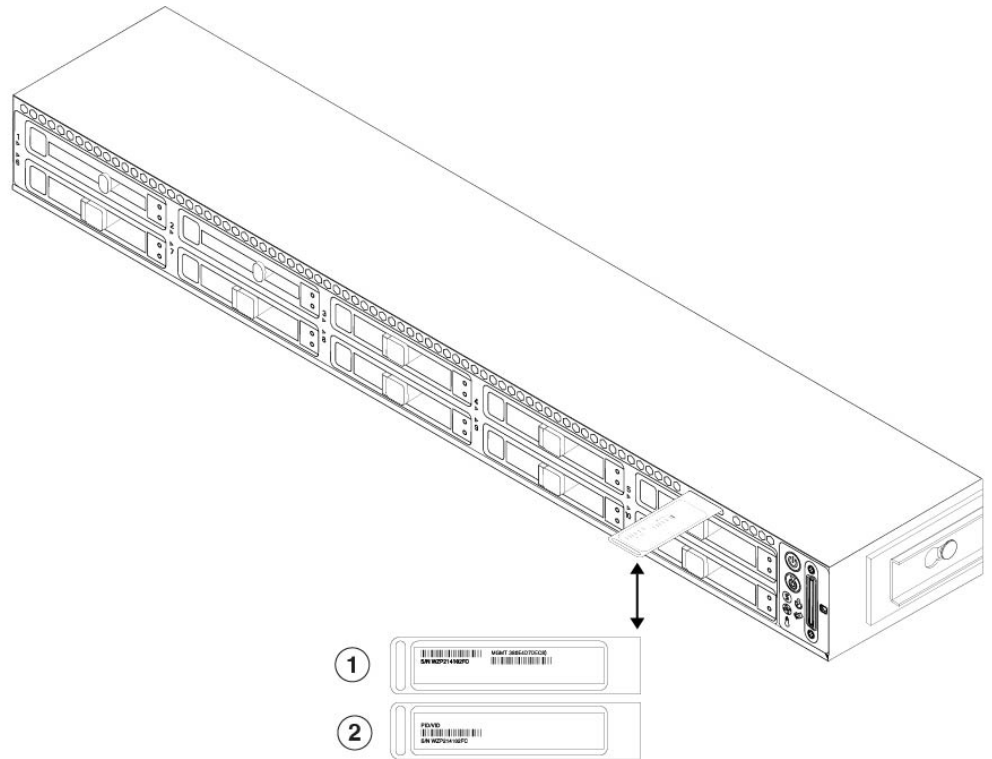

| | | | |
|----------|--|----------|--|
| 1 | Front of the pullout asset tag with the SN and MAC address | 2 | Bottom of the pullout asset tag with the PID and VID numbers |
|----------|--|----------|--|

The serial number is also on the label on the cover of the chassis as shown in the following figure.



Caution The cover latch on the top of the chassis cover is not supported. There are no internal field-replaceable parts in the 1700, 2700, and 4700.

Figure 4: Serial Number and Documentation Portal Location on the Cover

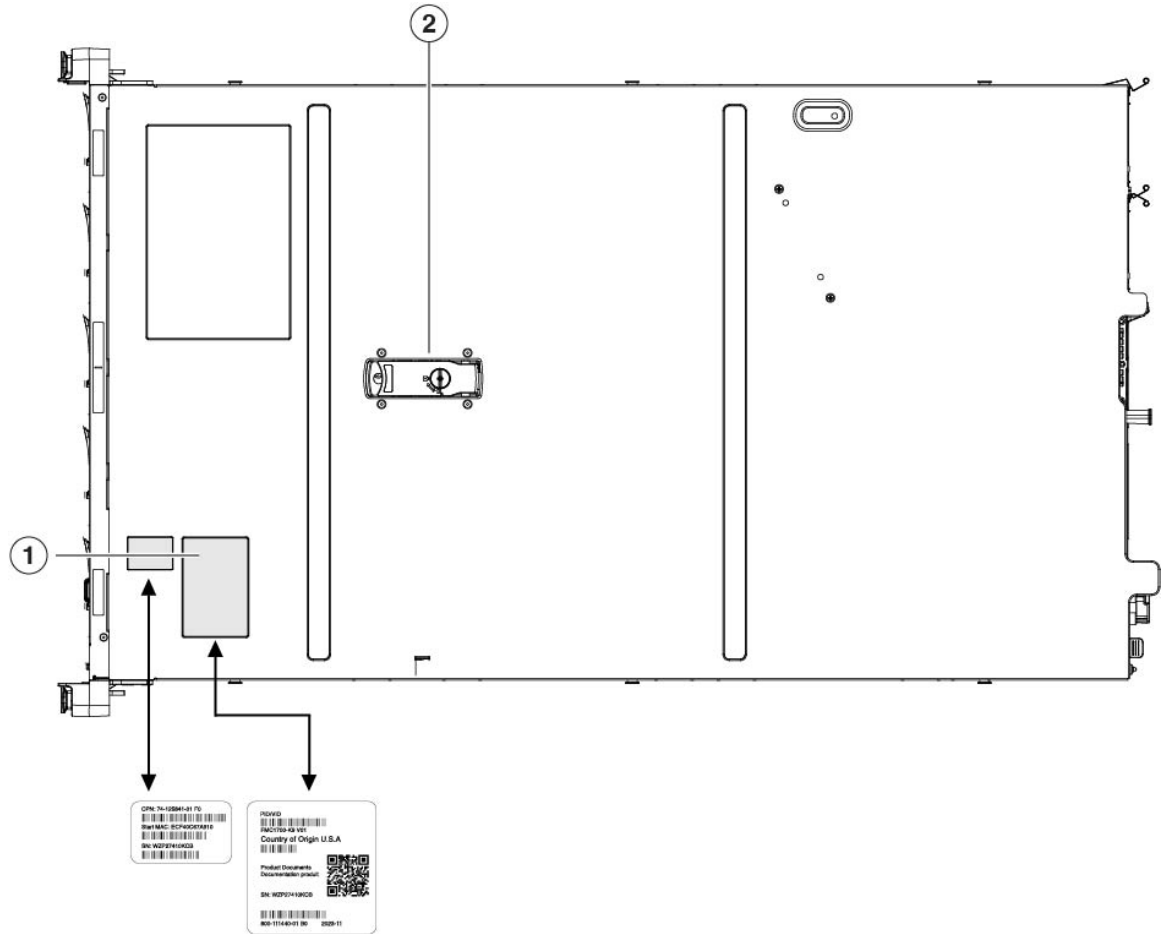

| | |
|---|---|
| <p>1 Chassis compliance labels with the SN, MAC address, etc. and a QR code that points to the Documentation Portal</p> <p>Note Scan the QR code to go to the Documentation Portal, which has links to the product page, hardware installation guide, the regulatory and compliance guide, and the getting started guide.</p> | <p>2 Cover latch Not supported</p> |
|---|---|

Front Panel

The following figure shows the front panel features and disk-drive configuration for the 1700. See [Front Panel LEDs, on page 9](#) for a description of the LEDs.

Figure 5: 1700 Front Panel

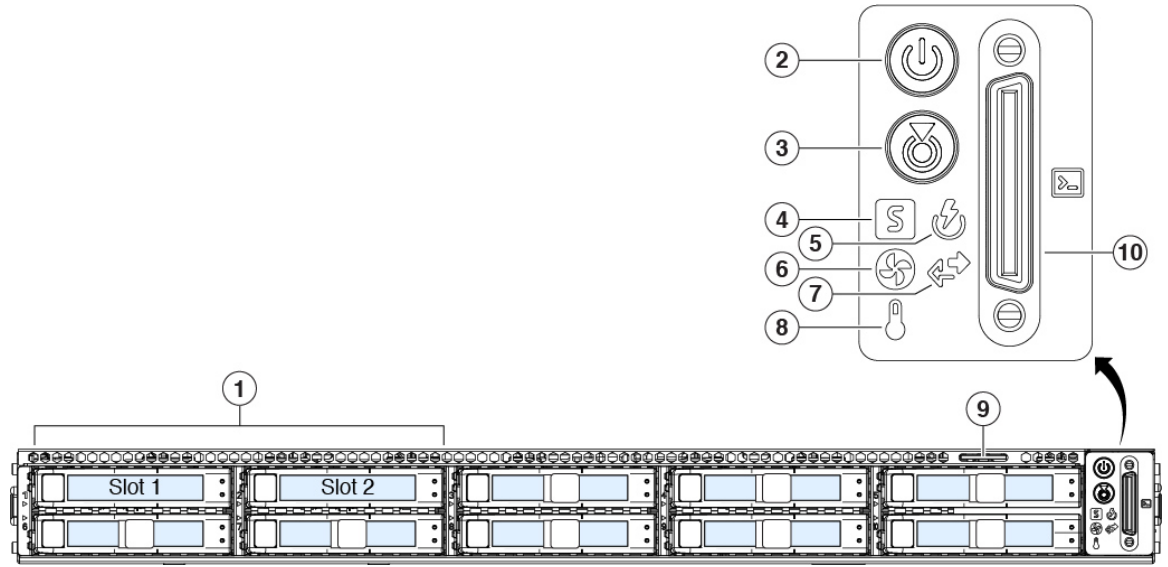

| | | | |
|---|--|----|---|
| 1 | Drive bays Supports two SAS HDDs in slots 1 and 2 | 2 | Power button/power status LED |
| 3 | Unit identification button/LED | 4 | System status LED |
| 5 | Power supply status LED | 6 | Fan status LED |
| 7 | Network link activity LED | 8 | Temperature status LED |
| 9 | Pullout asset card | 10 | Keyboard, video, and mouse (KVM) port Not supported; use the VGA and USB keyboard ports instead. |

The following figure shows the front panel features and disk-drive configuration for the 2700. See [Front Panel LEDs, on page 9](#) for a description of the LEDs.

Figure 6: 2700 Front Panel

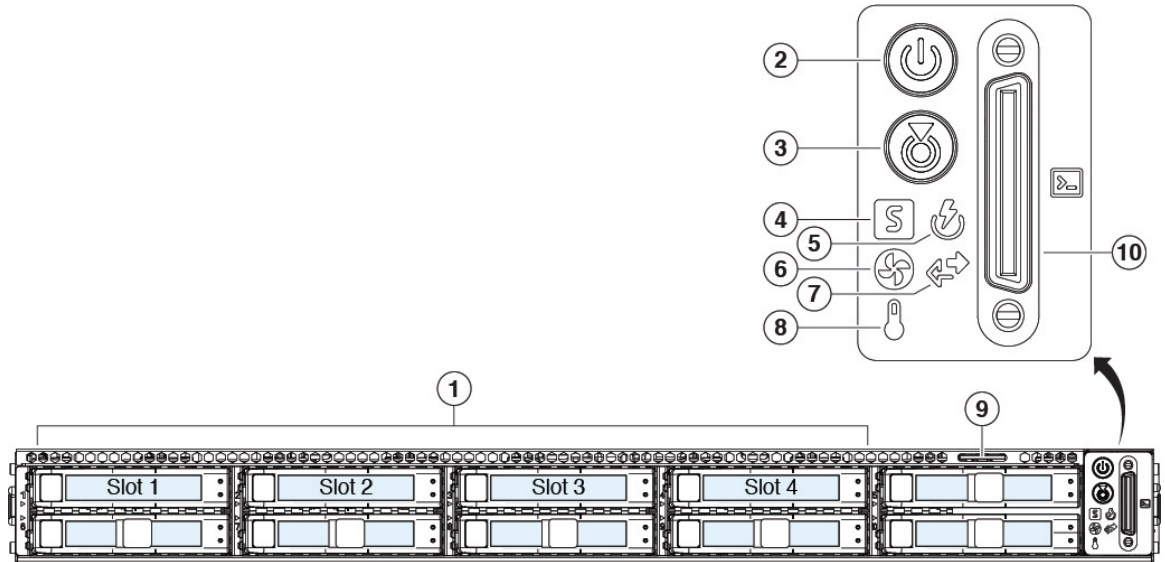

| | |
|--|--|
| 1 Drive bays Supports four SAS HDDs in slots 1 through 4 | 2 Power button/power status LED |
| 3 Unit identification button/LED | 4 System status LED |
| 5 Power supply status LED | 6 Fan status LED |
| 7 Network link activity LED | 8 Temperature status LED |
| 9 Pullout asset card | 10 KVM port Not supported; use the VGA and USB keyboard ports instead. |

The following figure shows the front panel features and disk-drive configuration for the 4700. See [Front Panel LEDs, on page 9](#) for a description of the LEDs.

Figure 7: 4700 Front Panel

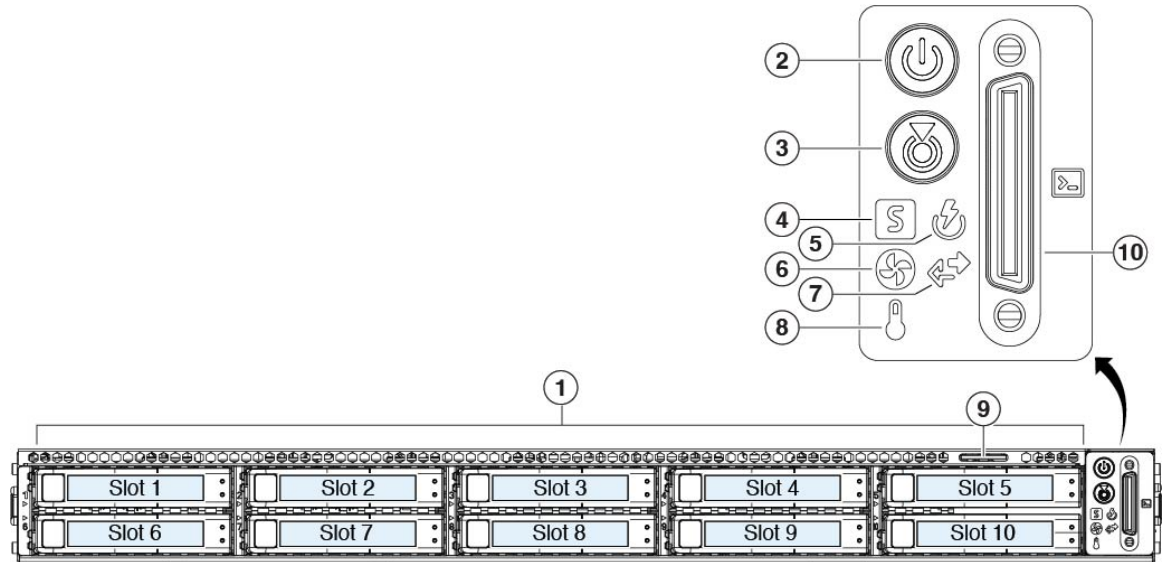

| | | | |
|---|---|----|--|
| 1 | Drive bays Supports ten SAS HDDs in slots 1 through 10 | 2 | Power button/power status LED |
| 3 | Unit identification button/LED | 4 | System status LED |
| 5 | Power supply status LED | 6 | Fan status LED |
| 7 | Network link activity LED | 8 | Temperature status LED |
| 9 | Pullout asset card | 10 | KVM port Not supported; use the VGA and USB keyboard ports instead. |

Front Panel LEDs

The following figure shows the front panel LEDs and describes their states.

Figure 8: Front Panel LEDs and Their States

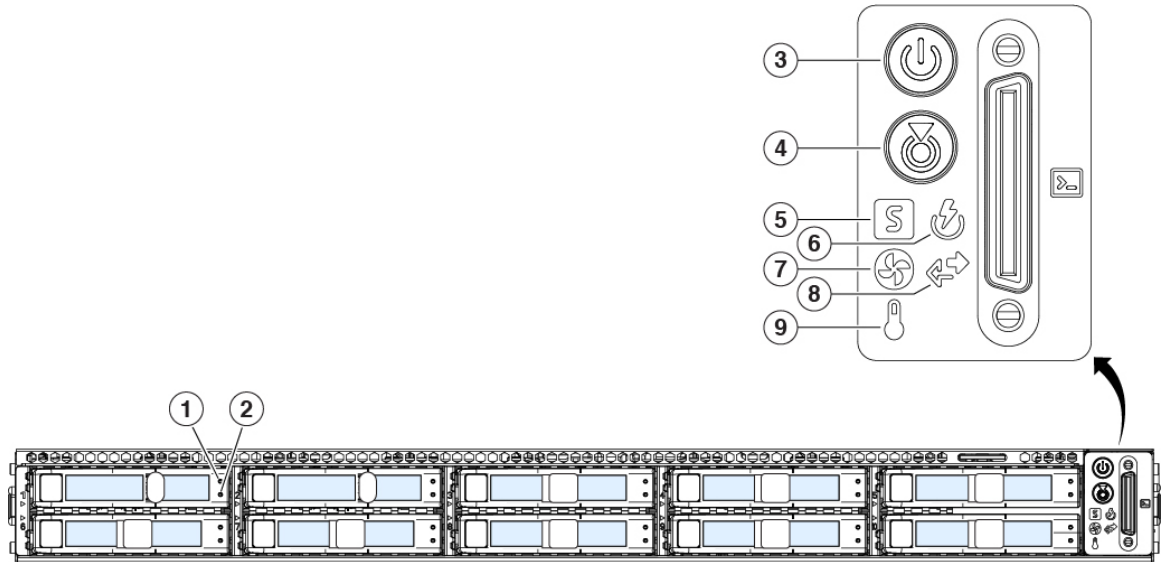

| | |
|---|--|
| <p>1 Drive fault LED:</p> <ul style="list-style-type: none"> • Off—The drive is operating properly. • Amber—Drive fault detected. • Amber, flashing—The drive is rebuilding. • Amber, flashing with 1-second interval—Drive locate function activated in the software. | <p>2 Drive activity LED:</p> <ul style="list-style-type: none"> • Off—There is no drive in the drive tray (no access, no fault). • Green—The drive is ready. • Green, flashing—The drive is reading or writing data. |
| <p>3 Power LED:</p> <ul style="list-style-type: none"> • Off—There is no AC power to the chassis. • Amber—The chassis is in standby mode. • Green—The chassis is in main power mode. Power is supplied to all components. | <p>4 Unit identification LED:</p> <ul style="list-style-type: none"> • Off—The unit identification function is not in use. • Blue, flashing—The unit identification function is activated. |

| | | | |
|---|--|---|--|
| 5 | <p>System status LED:</p> <ul style="list-style-type: none"> • Green—The chassis is running in normal operating condition. • Green, flashing—The chassis is performing system initialization and memory check. • Amber—The chassis is in a degraded operational state (minor fault). <ul style="list-style-type: none"> • Power supply redundancy is lost. • CPUs are mismatched. • At least one CPU is faulty. • At least one DIMM is faulty. • At least one drive in a RAID configuration failed. • Amber, two flashes—There is a major fault with the system board. • Amber, three flashes—There is a major fault with the DIMMs. • Amber, four flashes—There is a major fault with the CPUs. | 6 | <p>Power supply status LED:</p> <ul style="list-style-type: none"> • Green—All power supplies are operating normally. • Amber—One or more power supplies are in a degraded operational state. • Amber, flashing—One or more power supplies are in a critical fault state. |
| 7 | <p>Fan status LED:</p> <ul style="list-style-type: none"> • Green—All fans are operating properly. • Amber, flashing—One or more fans breached the unrecoverable threshold. | 8 | <p>Network link activity LED:</p> <ul style="list-style-type: none"> • Off—The Ethernet port link is idle. • Green—One or more Ethernet ports are link-active, but there is no activity. • Green, flashing—One or more Ethernet ports are link-active with activity. |
| 9 | <p>Temperature status LED:</p> <ul style="list-style-type: none"> • Green—The chassis is operating at normal temperature. • Amber—One or more temperature sensors breached the critical threshold. • Amber, flashing—One or more temperature sensors breached the unrecoverable threshold. | — | |

Rear Panel



Note The Cisco Integrated Management Controller (CIMC) is only supported for Lights-Out Management (LOM) access on the CIMC port (labeled M) on a Serial Over LAN (SOL) connection to remotely monitor or manage the management center system. For information on using LOM and SOL, see the "Set Up Lights Out Management" section in the [Cisco Secure Firewall Management Center 1700, 2700, and 4700 Getting Started Guide](#).

The following figure shows the rear panel of the 1700, 2700, and 4700.

Figure 9: 1700, 2700, and 4700 Rear Panel

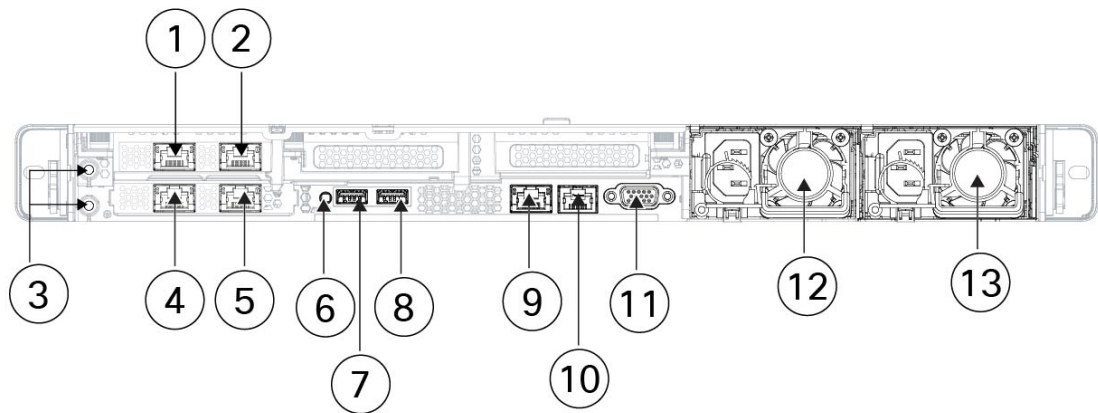

| | |
|---|--|
| <p>1 eth3 management interface (Optional) 10-Gigabit Ethernet SFP+ support Note See Features, on page 1 for the list of qualified SFPs.</p> | <p>2 eth2 management interface (Optional) 10-Gigabit Ethernet SFP+ support Note See Features, on page 1 for the list of qualified SFPs.</p> |
| <p>3 Threaded holes for dual-hole grounding lug</p> | <p>4 eth0 management interface (labeled 1) Supports 100/1000/10000 Mbps depending on link partner capability. Note See Features, on page 1 for the list of qualified SFPs.</p> |
| <p>5 eth1 management interface (labeled 2) Gigabit Ethernet 100/1000/10000 Mbps interface, RJ-45, LAN2 Note See Features, on page 1 for the list of qualified SFPs.</p> | <p>6 Unit identification button</p> |

| | | | |
|----|---|----|---|
| 7 | USB 3.0 Type A (USB 1) You can connect a keyboard, and along with a monitor on the VGA port, you can access the console. | 8 | USB 3.0 Type A (USB 2) You can connect a keyboard, and along with a monitor on the VGA port, you can access the console. |
| 9 | CIMC interface (labeled M) Note CIMC is supported <i>only</i> for LOM access. CIMC is <i>not</i> supported on any other interfaces. | 10 | Serial console port (RJ-45 connector) Disabled by default; use the VGA port and keyboard USB port instead. |
| 11 | VGA video port (DB-15 connector) | 12 | 1050-W AC power supply (PSU 1) |
| 13 | 1050-W AC power supply (PSU 2) | 14 | — |

Rear Panel LEDs

The following figure shows the rear panel LEDs and describes their states.

Figure 10: Rear Panel LEDs and Their States

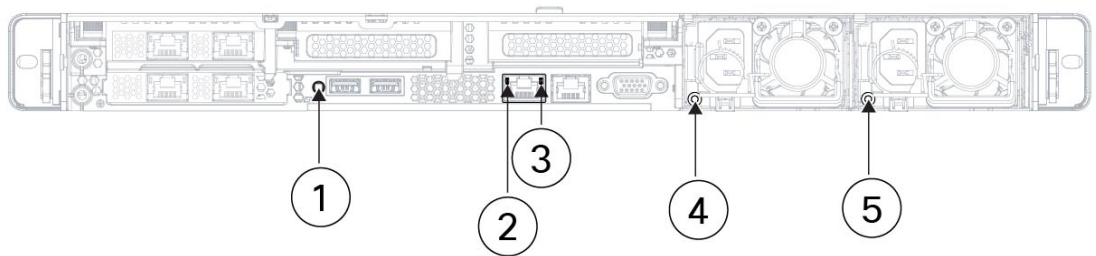

| | | | |
|---|--|---|---|
| 1 | Unit identification: <ul style="list-style-type: none"> • Off—The unit identification function is not in use. • Blue, flashing—The unit identification function is activated. | 2 | 100-Mbps/1-Gbps/10-Gbps Ethernet link (speed on both LAN1 and LAN2): <ul style="list-style-type: none"> • Off—Link speed is 100 Mbps. • Amber—Link speed is 1 Gbps. • Green—Link speed is 10 Gbps. |
| 3 | 100-Mbps/1-Gbps/10-Gbps Ethernet link status (speed on both LAN1 and LAN2): <ul style="list-style-type: none"> • Off—No link is present. • Green—Link is active. • Green, flashing—Traffic is present on the active link. | 4 | 1-Gbps Ethernet dedicated management link: <ul style="list-style-type: none"> • Off—Link speed is 10 Mbps. • Amber—Link speed is 100 Gbps. • Green—Link speed is 1 Gbps. |

| | | | |
|---|---|---|---|
| 5 | <p>1-Gbps Ethernet dedicated management link:</p> <ul style="list-style-type: none"> • Off—No link is present. • Amber—Link is active. • Green, flashing—Traffic is present on the active link. | 6 | <p>Power supply 1 (one LED for each power supply):</p> <ul style="list-style-type: none"> • Off—No AC input (12-V main power off; 12-V standby power off) • Green, flashing—12-V main power off; 12-V standby power on. • Green—12-V main power on; 12-V standby power on. • Amber, flashing—Warning threshold detected but 12-V main power on. • Amber—Critical error detected; 12-V main power off (for example, overcurrent, overvoltage, or overtemperature failure). |
| 7 | <p>Power supply 2 (one LED for each power supply):</p> <ul style="list-style-type: none"> • Off—No AC input (12-V main power off; 12-V standby power off) • Green, flashing—12-V main power off; 12-V standby power on. • Green—12-V main power on; 12-V standby power on. • Amber, flashing—Warning threshold detected but 12-V main power on. • Amber—Critical error detected; 12-V main power off (for example, overcurrent, overvoltage, or overtemperature failure). | — | |

Power Supply

The following table lists the specifications for each 1050-W AC power supply used in the 1700, 2700, and 4700.

Table 2: Power Supply Specifications

| Description | Specification |
|---------------------|---|
| Power consumption | 1313 BTU/hr |
| Input voltage range | Nominal range: 100 to 240 V AC Maximum range: 90 to 264 V AC |
| Input frequency | Nominal range: 50–60 Hz Maximum range: 47–63 Hz |

| Description | Specification |
|------------------------------|---|
| Maximum input current | 9.2 A peak at 100 V AC 5.2 A peak at 230 V AC |
| Maximum input volt amperes | 950 VA at 100 V AC |
| Maximum output power | 1050 W |
| Maximum inrush current | 15 A (subcycle duration) |
| Maximum hold-up time | 12 ms at 770 W |
| Maximum rated standby output | 36 W |
| Efficiency rating | Climate Savers Platinum Efficiency (80 Plus Platinum certified) |
| Form factor | RSP2 |
| Input connector | IEC320 C13/C15 |

Hardware Specifications

The following table lists the hardware specifications for the 1700, 2700, and 4700.

Table 3: 1700, 2700, and 4700 Hardware Specifications

| Specification | 1700 | 2700 | 4700 |
|------------------------|---|-------------------|-------------------|
| Dimensions (H x W x D) | 16.9 x 1.7 x 30 inches (42.9 x 4.3 x 76.2 cm) | | |
| Weight | 32.2 lb (16.6 kg) | 34.1 lb (16.8 kg) | 36.0 lb (17.0 kg) |
| Temperature | Operating: 50 to 95°F (10 to 35°C) Maximum temperature is derated by 1°F/547 ft (1°C/300 m) of altitude above 3117 ft (950 m). Nonoperating: -40 to 149°F (-40 to 65°C) When the appliance is stored or transported. | | |
| Relative humidity | Operating: 8 to 90% noncondensing Nonoperating: 5 to 95% noncondensing | | |
| Altitude | Operating: 0 to 10,000 ft Nonoperating: 0 to 40,000 ft when the appliance is stored or transported | | |
| Sound power level | 5.8 Bels (measure A-weighted per ISO7779 LWAd) Operation at 73°F (23°C) | | |

| Specification | 1700 | 2700 | 4700 |
|----------------------|--|------|------|
| Sound pressure level | 43 dBa (measure A-weighted per ISO7779 LpAM) Operation at 73°F (23°C) | | |

Product ID Numbers

The following table lists the field-replaceable PIDs associated with the 1700, 2700, and 4700. The spare components are ones that you can order and replace yourself. If any internal components fail, you must get a return material authorization (RMA) for the entire chassis including the SFPs and SFP cables. Remove the drives and power supplies before you send the chassis for RMA. See the [Cisco Returns Portal](#) for more information.

Table 4: 1700, 2700, and 4700 PIDs

| PID | Description |
|---------------------|--|
| FMC1700-K9 | Cisco Secure Firewall Management Center 1700 |
| FMC2700-K9 | Cisco Secure Firewall Management Center 2700 |
| FMC4700-K9 | Cisco Secure Firewall Management Center 4700 |
| FMC-M6-PS-AC-1050W | AC power supply |
| FMC-M6-PS-AC-1050W= | AC power supply (spare) |
| FMC-M6-HDD-1.2TB | 1700 and 4700 1.2-TB drive |
| FMC-M6-HDD-1.2TB= | 1700 and 4700 1.2-TB drive (spare) |
| FMC-M6-HDD-600G | 2700 600-GB drive |
| FMC-M6-HDD-600G= | 2700 600-GB drive (spare) |
| UCSC-RAIL-M6 | Rail kit |

Power Cord Specifications

Each power supply has a separate power cord. Standard power cords or jumper power cords are available for connection to the 1700, 2700, and 4700. The jumper power cords for use in racks are available as an optional alternative to the standard power cords.

If you do not order the optional power cord with the system, you are responsible for selecting the appropriate power cord for the product. Using an incompatible power cord with this product may result in electrical safety hazard. Orders delivered to Argentina, Brazil, and Japan must have the appropriate power cord ordered with the system.



Note Only the approved power cords and jumper cords provided with the 1700, 2700, and 4700 are supported.

The following power cords and jumper cords are supported.

Figure 11: Argentina (CAB-250V-10A-AR)

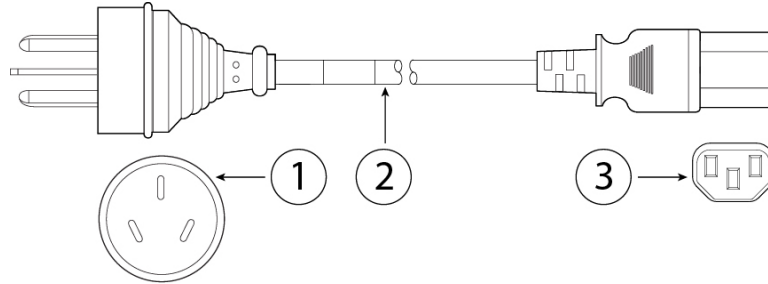

| | | | |
|----------|--------------------------|----------|------------------------------|
| 1 | Plug: IRAM 2073 | 2 | Cord set rating: 10 A, 250 V |
| 3 | Connector: IEC 60320/C13 | | — |

Figure 12: Australia (CAB-9K10A-AU)

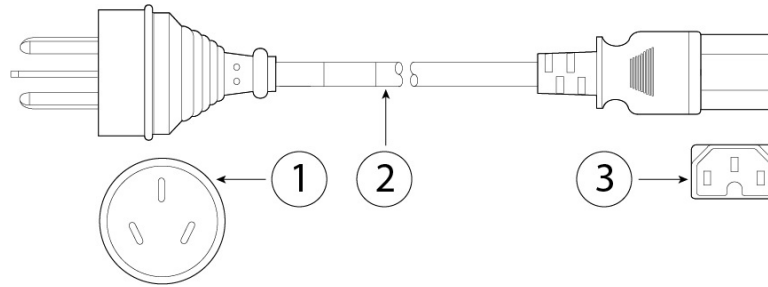

| | | | |
|----------|--------------------------|----------|------------------------------|
| 1 | Plug: A.S. 3112-2000 | 2 | Cord set rating: 10 A, 250 V |
| 3 | Connector: IEC 60320/C15 | | — |

Figure 13: Brazil (PWR-250V-10A-BZ)

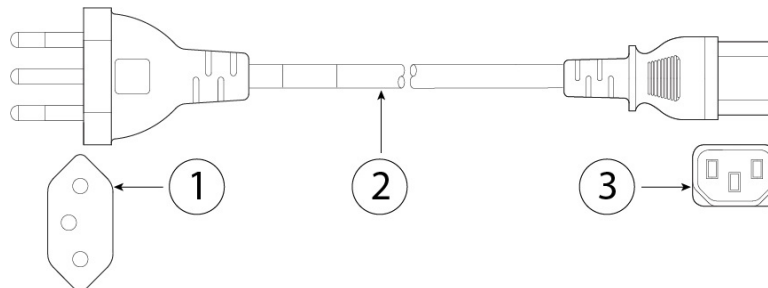

| | | | |
|----------|--------------------------|----------|------------------------------|
| 1 | Plug: NBR 14136 | 2 | Cord set rating: 10 A, 250 V |
| 3 | Connector: IEC 60320/C13 | | — |

Figure 14: Cabinet Jumper (CAB-C13-C14-2M)

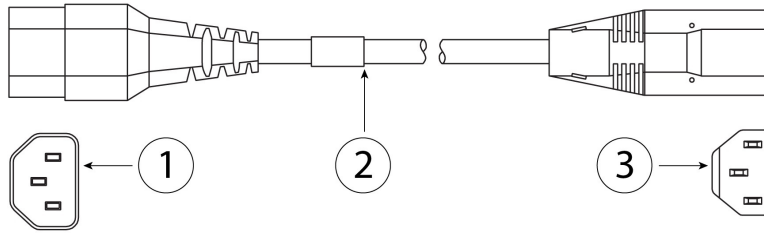

| | | | |
|----------|--------------------------------|----------|----------------------------|
| 1 | Plug: SS10A | 2 | Cord set rating: 10A, 250V |
| 3 | Connector: HS10S, C-13 to C-14 | | — |

Figure 15: Cabinet Jumper (CAB-C13-C14-AC)

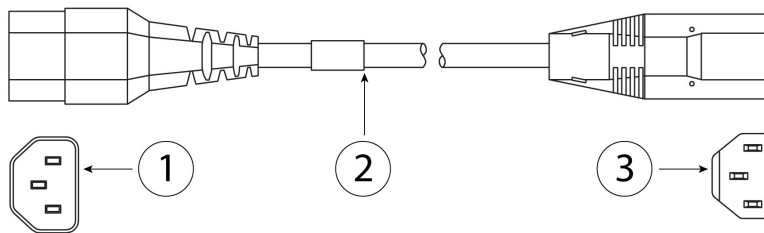

| | | | |
|----------|--|----------|------------------------------|
| 1 | Plug: SS10A | 2 | Cord set rating: 10 A, 250 V |
| 3 | Connector: HS10S, C-13 to C-14 (recessed receptacle) | | — |

Figure 16: Cabinet Jumper (CAB-C13-CBN)

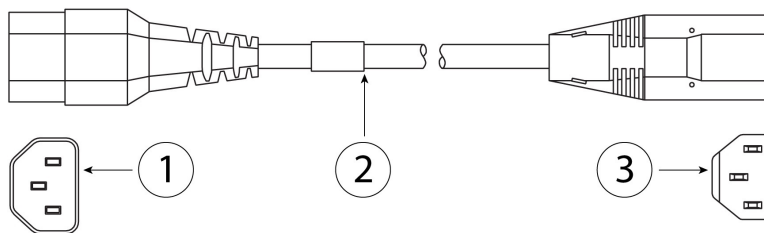

| | | | |
|----------|--------------------------------|----------|------------------------------|
| 1 | Plug: SS10A | 2 | Cord set rating: 10 A, 250 V |
| 3 | Connector: HS10S, C-13 to C-14 | | — |

Figure 17: China (CAB-250V-10A-CH)

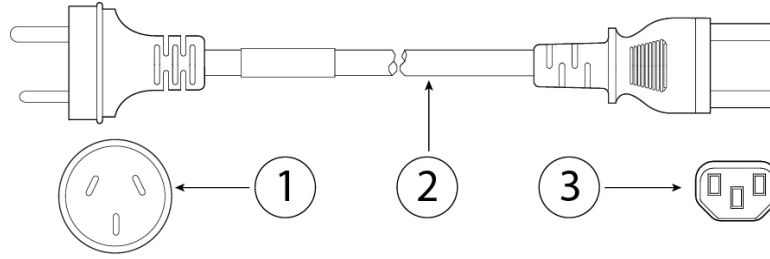

| | | | |
|----------|--------------------------|----------|------------------------------|
| 1 | Plug: GB2099.1/2008 | 2 | Cord set rating: 10 A, 250 V |
| 3 | Connector: IEC 60320/C13 | | — |

Figure 18: Europe (CAB-9K10A-EU)

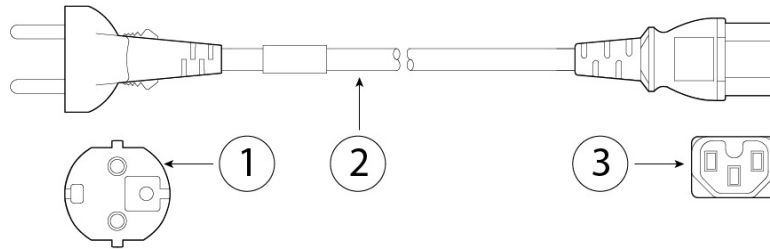

| | | | |
|----------|------------------------------------|----------|-----------------------------------|
| 1 | Plug: CEE 7/7 (M2511) | 2 | Cord set rating: 10 A/16 A, 250 V |
| 3 | Connector: IEC 60320/C15 (VSCC 15) | | — |

Figure 19: India (CAB-250V-10A-ID)

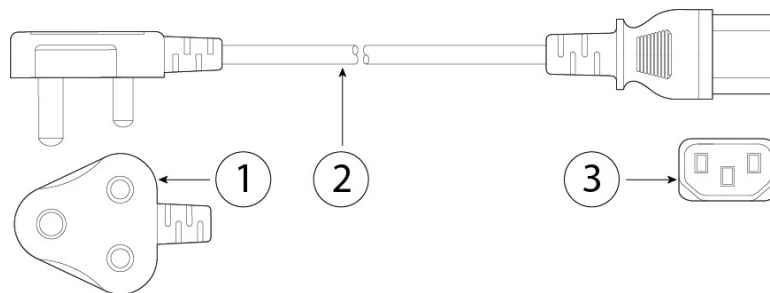

| | | | |
|----------|--------------------------|----------|------------------------------|
| 1 | Plug: IS 6538-1971 | 2 | Cord set rating: 16 A, 250 V |
| 3 | Connector: IEC 60320-C13 | | — |

Figure 20: Israel (CAB-250V-10A-IS)

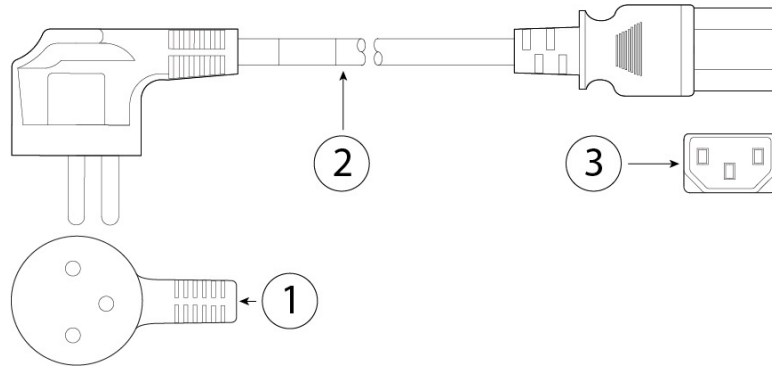

| | | | |
|----------|--------------------------|----------|------------------------------|
| 1 | Plug: SI-32 | 2 | Cord set rating: 10 A, 250 V |
| 3 | Connector: IEC 60320-C13 | | — |

Figure 21: Italy (CAB-9K10A-IT)

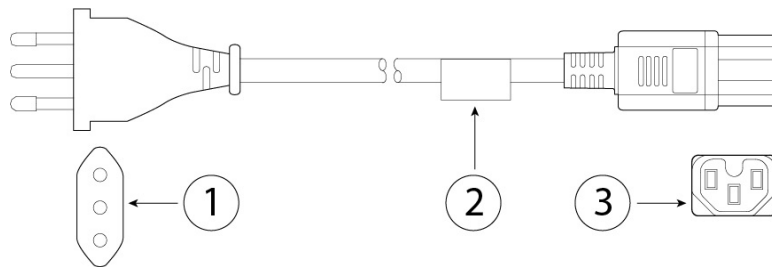

| | | | |
|----------|---|----------|------------------------------|
| 1 | Plug: CEI 23-16/VII (I/3G) | 2 | Cord set rating: 10 A, 250 V |
| 3 | Connector: IEC 60320/C15 (EN 60320/C15M) | | — |

Figure 22: Japan (CAB-JPN-3PIN)

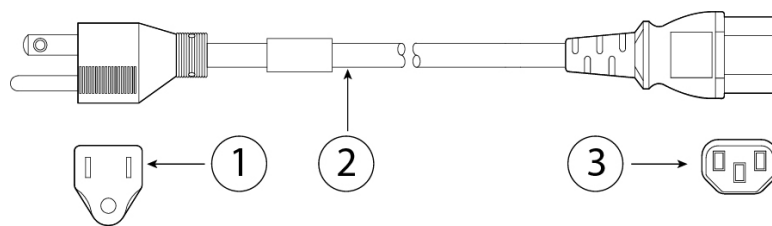

| | | | |
|----------|--------------------------|----------|------------------------------|
| 1 | Plug: JIS 8303 | 2 | Cord set rating: 12 A, 125 V |
| 3 | Connector: IEC 60320/C13 | | — |

Figure 23: Japan (CAB-C13-C14-2M-JP)

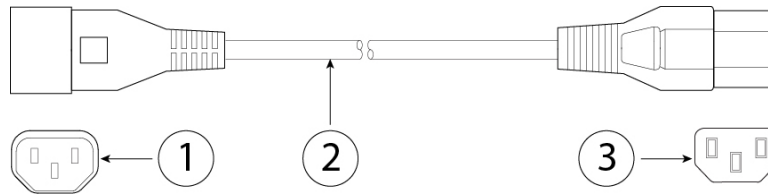

| | | | |
|----------|--------------------------------|----------|------------------------------|
| 1 | Plug: EN 60320-2-2/E | 2 | Cord set rating: 10 A, 250 V |
| 3 | Connector: EN 60320/C13 to C14 | | — |

Figure 24: Korea (CAB-9K10S-KOR)

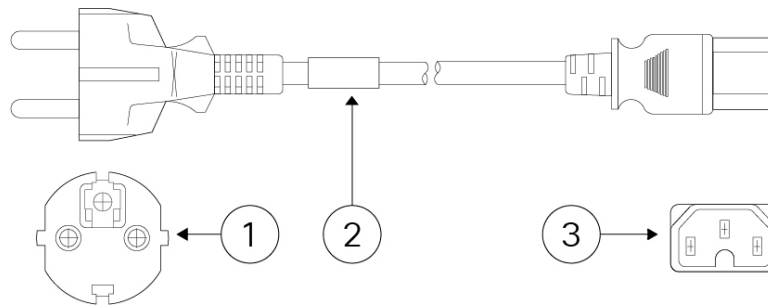

| | | | |
|----------|--------------------------|----------|------------------------------|
| 1 | Plug: EL211 (KSC 8305) | 2 | Cord set rating: 10 A, 250 V |
| 3 | Connector: IEC 60320/C15 | | — |

Figure 25: North America (CAB-9K12A-NA)

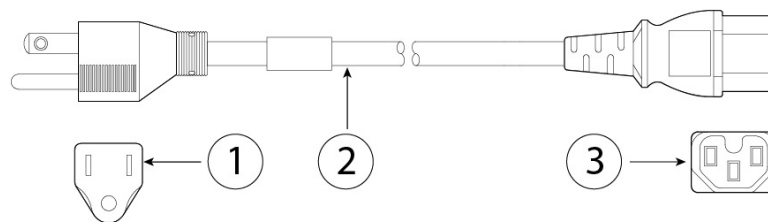

| | | | |
|----------|--------------------------|----------|------------------------------|
| 1 | Plug: NEMA5-15P | 2 | Cord set rating: 13 A, 125 V |
| 3 | Connector: IEC 60320/C15 | | — |

Figure 26: North America (CAB-N5K6A-NA)

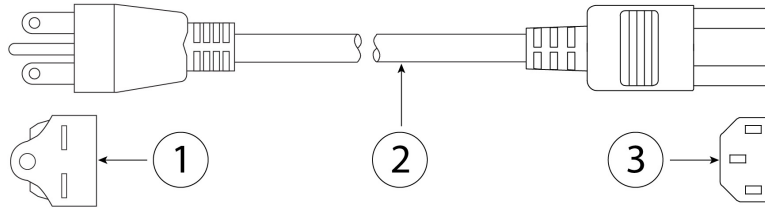

| | | | |
|----------|--------------------------|----------|------------------------------|
| 1 | Plug: NEMA6-15P | 2 | Cord set rating: 10 A, 125 V |
| 3 | Connector: IEC 60320/C13 | | — |

Figure 27: North America (CAB-AC-L620-C13)

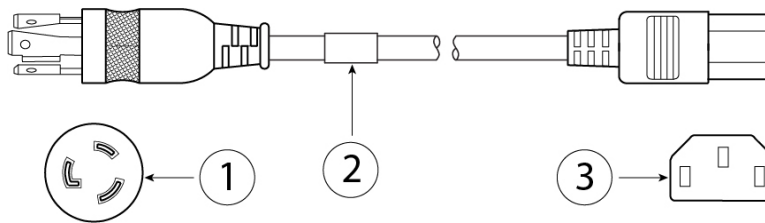

| | | | |
|----------|--------------------------------------|----------|------------------------------|
| 1 | Plug: NEMA L6-20 (molded twist lock) | 2 | Cord set rating: 13 A, 250 V |
| 3 | Connector: IEC 60320/C13 | | — |

Figure 28: Switzerland (CAB-9K10A-SW)

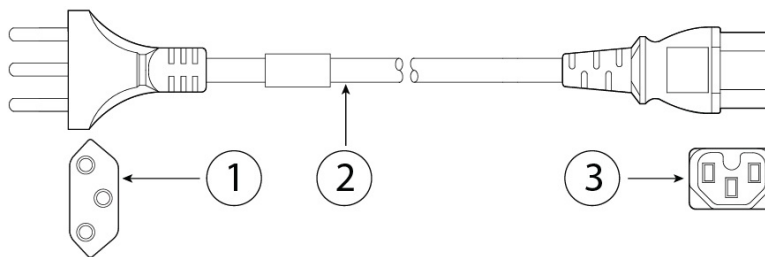

| | | | |
|----------|--------------------------|----------|------------------------------|
| 1 | Plug: SEV 1011 (MP232-R) | 2 | Cord set rating: 10 A, 250 V |
| 3 | Connector: IEC 60320/C15 | | — |

Figure 29: Taiwan (CAB-ACTW)

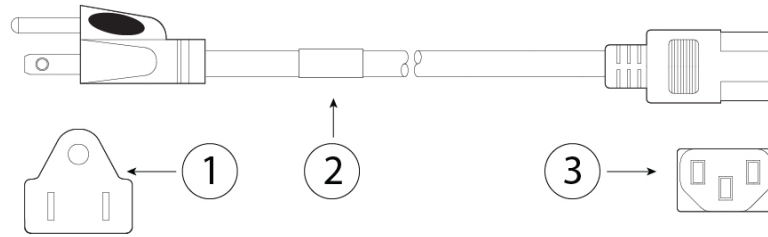

| | | | |
|----------|--------------------------|----------|------------------------------|
| 1 | Plug: EL 302 (CNS10917) | 2 | Cord set rating: 10 A, 125 V |
| 3 | Connector: IEC 60320/C13 | | — |

Figure 30: United Kingdom (CAB-9K10A-UK)

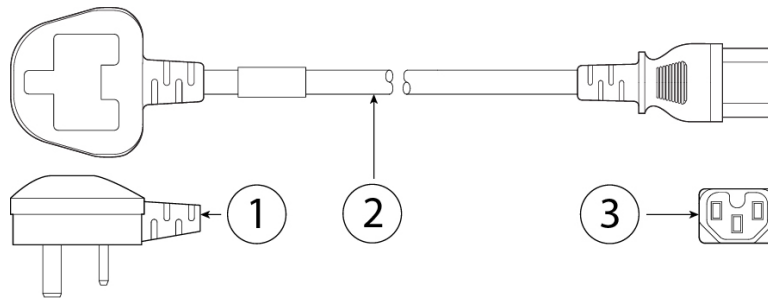

| | | | |
|----------|--------------------------|----------|------------------------------|
| 1 | Plug: BS1363A/SS145 | 2 | Cord set rating: 10 A, 250 V |
| 3 | Connector: IEC 60320/C15 | | — |

