



Cisco Secure Network Server 3600 Series Appliance Hardware Installation Guide

Americas Headquarters

Cisco Systems, Inc.
170 West Tasman Drive
San Jose, CA 95134-1706
USA
<http://www.cisco.com>
Tel: 408 526-4000
800 553-NETS (6387)
Fax: 408 527-0883

THE SPECIFICATIONS AND INFORMATION REGARDING THE PRODUCTS IN THIS MANUAL ARE SUBJECT TO CHANGE WITHOUT NOTICE. ALL STATEMENTS, INFORMATION, AND RECOMMENDATIONS IN THIS MANUAL ARE BELIEVED TO BE ACCURATE BUT ARE PRESENTED WITHOUT WARRANTY OF ANY KIND, EXPRESS OR IMPLIED. USERS MUST TAKE FULL RESPONSIBILITY FOR THEIR APPLICATION OF ANY PRODUCTS.

THE SOFTWARE LICENSE AND LIMITED WARRANTY FOR THE ACCOMPANYING PRODUCT ARE SET FORTH IN THE INFORMATION PACKET THAT SHIPPED WITH THE PRODUCT AND ARE INCORPORATED HEREIN BY THIS REFERENCE. IF YOU ARE UNABLE TO LOCATE THE SOFTWARE LICENSE OR LIMITED WARRANTY, CONTACT YOUR CISCO REPRESENTATIVE FOR A COPY.

The Cisco implementation of TCP header compression is an adaptation of a program developed by the University of California, Berkeley (UCB) as part of UCB's public domain version of the UNIX operating system. All rights reserved. Copyright © 1981, Regents of the University of California.

NOTWITHSTANDING ANY OTHER WARRANTY HEREIN, ALL DOCUMENT FILES AND SOFTWARE OF THESE SUPPLIERS ARE PROVIDED "AS IS" WITH ALL FAULTS. CISCO AND THE ABOVE-NAMED SUPPLIERS DISCLAIM ALL WARRANTIES, EXPRESSED OR IMPLIED, INCLUDING, WITHOUT LIMITATION, THOSE OF MERCHANTABILITY, FITNESS FOR A PARTICULAR PURPOSE AND NON-INFRINGEMENT OR ARISING FROM A COURSE OF DEALING, USAGE, OR TRADE PRACTICE.

IN NO EVENT SHALL CISCO OR ITS SUPPLIERS BE LIABLE FOR ANY INDIRECT, SPECIAL, CONSEQUENTIAL, OR INCIDENTAL DAMAGES, INCLUDING, WITHOUT LIMITATION, LOST PROFITS OR LOSS OR DAMAGE TO DATA ARISING OUT OF THE USE OR INABILITY TO USE THIS MANUAL, EVEN IF CISCO OR ITS SUPPLIERS HAVE BEEN ADVISED OF THE POSSIBILITY OF SUCH DAMAGES.

Any Internet Protocol (IP) addresses and phone numbers used in this document are not intended to be actual addresses and phone numbers. Any examples, command display output, network topology diagrams, and other figures included in the document are shown for illustrative purposes only. Any use of actual IP addresses or phone numbers in illustrative content is unintentional and coincidental.

All printed copies and duplicate soft copies of this document are considered uncontrolled. See the current online version for the latest version.

Cisco has more than 200 offices worldwide. Addresses and phone numbers are listed on the Cisco website at www.cisco.com/go/offices.

The documentation set for this product strives to use bias-free language. For purposes of this documentation set, bias-free is defined as language that does not imply discrimination based on age, disability, gender, racial identity, ethnic identity, sexual orientation, socioeconomic status, and intersectionality. Exceptions may be present in the documentation due to language that is hardcoded in the user interfaces of the product software, language used based on standards documentation, or language that is used by a referenced third-party product.

Cisco and the Cisco logo are trademarks or registered trademarks of Cisco and/or its affiliates in the U.S. and other countries. To view a list of Cisco trademarks, go to this URL: <https://www.cisco.com/c/en/us/about/legal/trademarks.html>. Third-party trademarks mentioned are the property of their respective owners. The use of the word partner does not imply a partnership relationship between Cisco and any other company. (1721R)

© 2019 Cisco Systems, Inc. All rights reserved.



CONTENTS

CHAPTER 1	Cisco Secure Network Server 3600 Series Appliance Overview	1
	Cisco Secure Network Server 3600 Series Appliances	1
	Cisco SNS 3600 Series Appliance Hardware Specifications	1
	External Features	3
	Status LEDs and Buttons	5
	Front Panel LEDs	6
	Rear Panel LEDs	8
	Internal Diagnostic LEDs	9
	Serviceable Component Locations	10
	Summary of Server Features	11

CHAPTER 2	Installing the Appliance	15
	Installation Warnings and Guidelines	15
	Rack Requirements	16
	Installing the Appliance in a Rack	17
	Installing the Cable Management Arm (Optional)	19
	Reversing the Cable Management Arm (Optional)	20
	Initial Setup	21
	Connecting to the Appliance Locally For Setup	22
	Connecting to the Appliance Remotely For Setup	23
	Setting Up the System With the Cisco IMC Configuration Utility	24
	Updating the BIOS and Cisco IMC Firmware	26
	Accessing the System BIOS	26
	Smart Access Serial	26

CHAPTER 3	Server Specifications	29
------------------	------------------------------	-----------

Server Specifications	29
Physical Specifications	29
Environmental Specifications	29
Power Specifications	30
770 W AC Power Supply	30
1050 W AC Power Supply	31
1600 W AC Power Supply	32
1050 W DC Power Supply	32
Power Cord Specifications	33



CHAPTER 1

Cisco Secure Network Server 3600 Series Appliance Overview

- [Cisco Secure Network Server 3600 Series Appliances](#), on page 1
- [Cisco SNS 3600 Series Appliance Hardware Specifications](#) , on page 1
- [External Features](#), on page 3
- [Serviceable Component Locations](#), on page 10
- [Summary of Server Features](#), on page 11

Cisco Secure Network Server 3600 Series Appliances

Cisco Secure Network Server (SNS) 3600 series appliances are designed to deliver high performance and efficiency for a wide range of workloads.

Cisco SNS 3600 series appliances support the Unified Extensible Firmware Interface (UEFI) secure boot feature. This feature ensures that only a Cisco-signed ISE image can be installed on the Cisco SNS 3600 series appliances, and prevents installation of any unsigned operating system even with physical access to the device. For example, generic operating systems, such as Red Hat Enterprise Linux or Microsoft Windows cannot boot on this appliance.

Cisco SNS 3600 Series Appliance Hardware Specifications

The following table describes the hardware specifications of Cisco SNS 3600 series appliances.

Table 1: Cisco SNS 3600 Series Appliance Hardware Specifications

Cisco SNS 3600 Series Appliance	Hardware Specifications	Diagrams
Cisco SNS-3615-K9	<ul style="list-style-type: none"> • Cisco UCS C220 M5 • Intel Xeon Silver 2.1 GHz 4110, 8 CPU Cores, 16 Threads • 32 GB RAM • 1 x 600-GB disk • RAID-0 • 6 x GbE network interfaces • For physical, environmental, and power specifications, see Server Specifications, on page 29 	<p>Figure 1: Cisco SNS 3600 Series Appliance Front Panel, on page 4</p> <p>Figure 2: Cisco SNS 3600 Series Appliance Rear Panel, on page 5</p>
Cisco SNS-3655-K9	<ul style="list-style-type: none"> • Cisco UCS C220 M5 • Intel Xeon Silver 2.1 GHz 4116, 12 CPU Cores, 24 Threads • 96 GB RAM • 4 x 600-GB disk • RAID 10 • 6 x GbE network interfaces • For physical, environmental, and power specifications, see Server Specifications, on page 29 	
Cisco SNS-3695-K9		

Cisco SNS 3600 Series Appliance	Hardware Specifications	Diagrams
	<ul style="list-style-type: none"> • Cisco UCS C220 M5 • Intel Xeon Silver 2.1 GHz 4116, 12 CPU Cores, 24 Threads • 256 GB RAM • 8 x 600-GB disk • RAID 10 • 6 x GbE network interfaces • For physical, environmental, and power specifications, see Server Specifications, on page 29 	



Note You cannot add additional hardware resources like memory, processor, or hard disk to a Cisco SNS 3600 series appliance.

External Features

This section describes the external features of Cisco SNS 3600 series appliance.

Cisco SNS 3600 Front Panel Features

The following figure shows the front panel features of Cisco SNS 3600 series appliance.

For definitions of LED states, see [Front Panel LEDs, on page 6](#).

Figure 1: Cisco SNS 3600 Series Appliance Front Panel

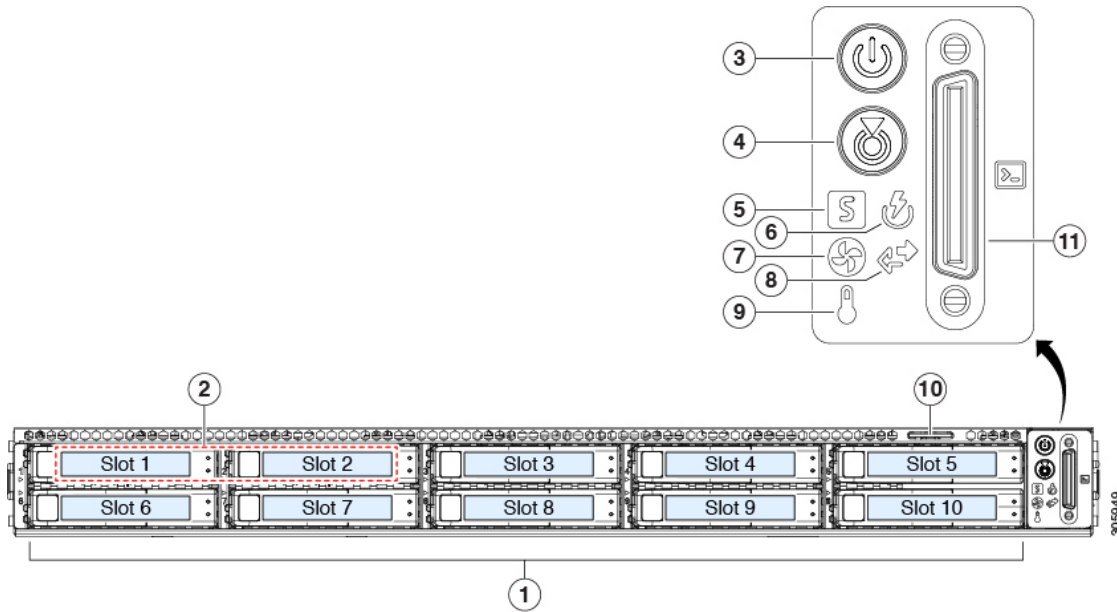

Drive bays 1 – 10 support Serial Attached SCSI (SAS) and Serial Advanced Technology Attachment (SATA) hard disk drives (HDDs) and solid state drives (SSDs)	Fan status LED
Drive bays 1 – 10 support Non-Volatile Memory express (NVMe) based Peripheral Component Interconnect Express (PCIe) SSDs	Network link activity LED
Power button or power status LED	Temperature status LED
Unit identification button or LED	Pull-out asset tag
System status LED	KVM connector (used with KVM cable that provides one DB-15 VGA, one DB-9 serial, and two USB connectors)
Power supply status LED	-

Cisco SNS 3600 Series Appliance Rear Panel Features

The following figure shows the rear panel features of Cisco SNS 3600 series appliance.

For definitions of LED states, see [Rear Panel LEDs](#), on page 8.

Figure 2: Cisco SNS 3600 Series Appliance Rear Panel

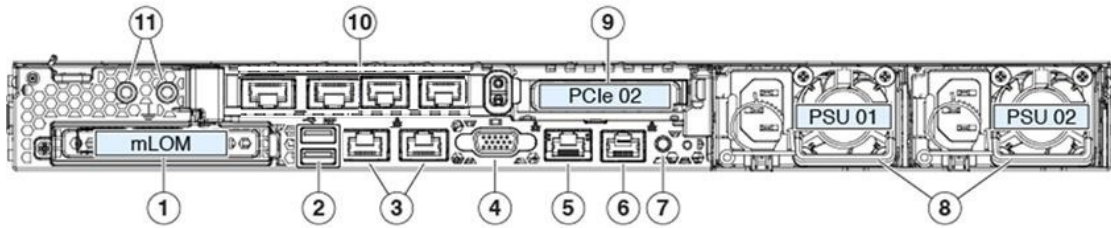

Modular LAN-on-motherboard (mLOM) card bay (x16 PCIe lane)	Rear unit identification button or LED
Two USB 3.0 ports	Power supplies (two, redundant as 1+1)
<p>Dual 1-Gb or 10-Gb Ethernet ports:</p> <ul style="list-style-type: none"> • LAN1 (linked to Cisco ISE GigabitEthernet 0 interface) • LAN2 (linked to Cisco ISE GigabitEthernet 1 interface) <p>Note The interface labelling is from left to right.</p> <p>The dual LAN ports can support 1 Gbps or 10 Gbps depending on the link partner capability.</p>	<p>PCIe riser 2 or slot 2 (x16 lane)</p> <p>Includes PCIe cable connectors for front-loading NVMe SSDs (x8 lane)</p>
VGA video port (DB-15 connector)	<p>PCIe 1: Four Ethernet ports that are mapped to the following Cisco ISE GigabitEthernet interfaces:</p> <ul style="list-style-type: none"> • GigabitEthernet 2 interface • GigabitEthernet 3 interface • GigabitEthernet 4 interface • GigabitEthernet 5 interface <p>Note The interface labelling is from left to right.</p>
5-Gb Ethernet dedicated management port	Threaded holes for dual-hole grounding lug
Serial port (RJ-45 connector)	-

Status LEDs and Buttons

This section contains information for interpreting front, rear, and internal LED states.

Front Panel LEDs

The following figure shows the front panel LEDs of Cisco SNS 3600 series appliance.

Figure 3: Front Panel LEDs

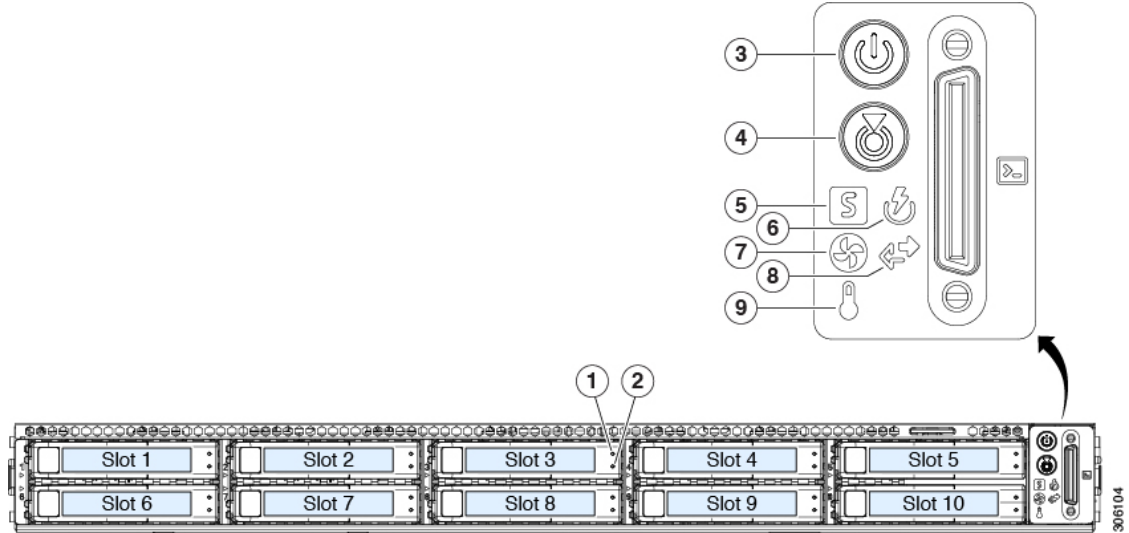

Table 2: Front Panel LEDs

LED Name	States
SAS/SATA drive fault Note NVMe SSD drive tray LEDs have different behavior than SAS/SATA drive trays.	<ul style="list-style-type: none"> • Off—The hard drive is operating properly. • Amber—Drive fault detected. • Amber, blinking—The device is rebuilding. • Amber, blinking with one-second interval—Drive locate function activated in the software.
SAS/SATA drive activity LED S	<ul style="list-style-type: none"> • Off—There is no hard drive in the hard drive tray (no access, no fault). • Green—The hard drive is ready. • Green, blinking—The hard drive is reading or writing data.
NVMe SSD drive fault Note NVMe SSD drive tray LEDs have different behavior than SAS/SATA drive trays.	<ul style="list-style-type: none"> • Off—The drive is not in use and can be safely removed. • Green—The drive is in use and functioning properly. • Green, blinking—The driver is initializing following insertion or the driver is unloading following an eject command. • Amber—The drive has failed. • Amber, blinking—Drive locate function activated in the software.

<p>NVMe SSD activity</p>	<ul style="list-style-type: none"> • Off—No drive activity. • Green, blinking—There is drive activity.
<p>Power button or LED</p>	<ul style="list-style-type: none"> • Off—There is no AC power to the server. • Amber—The server is in standby power mode. Power is supplied only to the Cisco Integrated Management Controller (Cisco IMC) and some motherboard functions. • Green—The server is in main power mode. Power is supplied to all server components.
<p>Unit identification</p>	<ul style="list-style-type: none"> • Off—The unit identification function is not in use. • Blue, blinking—The unit identification function is activated.
<p>System health</p>	<ul style="list-style-type: none"> • Green—The server is running in normal operating condition. • Green, blinking—The server is performing system initialization and memory check. • Amber, steady—The server is in a degraded operational state (minor fault). For example: <ul style="list-style-type: none"> • Power supply redundancy is lost. • CPUs are mismatched. • At least one CPU is faulty. • At least one dual in-line memory module (DIMM) is faulty. • At least one drive in a RAID configuration failed. • Amber, 2 blinks—There is a major fault with the system board. • Amber, 3 blinks—There is a major fault with the DIMMs. • Amber, 4 blinks—There is a major fault with the CPUs.
<p>Power supply status</p>	<ul style="list-style-type: none"> • Green—All power supplies are operating normally. • Amber, steady—One or more power supplies are in a degraded operational state. • Amber, blinking—One or more power supplies are in a critical fault state.
<p>Fan status</p>	<ul style="list-style-type: none"> • Green—All fan modules are operating properly. • Amber, blinking—One or more fan modules breached the non-recoverable threshold.

Network link activity	<ul style="list-style-type: none"> • Off—The Ethernet Lights Out Management (LOM) port link is idle. • Green—One or more Ethernet LOM ports are link-active, but there is no activity. • Green, blinking—One or more Ethernet LOM ports are link-active, with activity.
Temperature status	<ul style="list-style-type: none"> • Green—The server is operating at normal temperature. • Amber, steady—One or more temperature sensors breached the critical threshold. • Amber, blinking—One or more temperature sensors breached the non-recoverable threshold.

Rear Panel LEDs

The following figure shows the rear panel LEDs of Cisco SNS 3600 series appliance.

Figure 4: Rear Panel LEDs

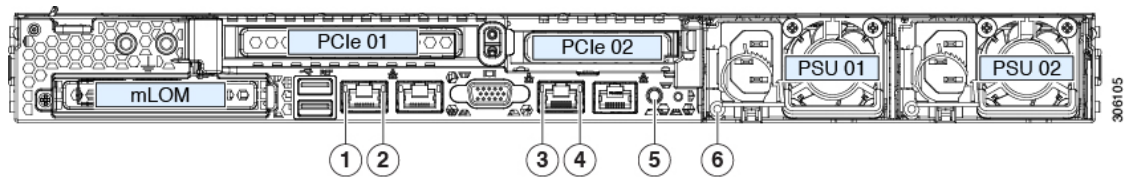

Table 3: Rear Panel LEDs

	LED Name	States
1	1-Gb or 10-Gb Ethernet link speed (on both LAN1 and LAN2)	<ul style="list-style-type: none"> • Off—Link speed is 100 Mbps. • Amber—Link speed is 1 Gbps. • Green—Link speed is 10 Gbps.
2	1-Gb or 10-Gb Ethernet link status (on both LAN1 and LAN2)	<ul style="list-style-type: none"> • Off—No link is present. • Green—Link is active. • Green, blinking—Traffic is present on the active link.
3	1-Gb Ethernet dedicated management link speed	<ul style="list-style-type: none"> • Off—Link speed is 10 Mbps. • Amber—Link speed is 100 Mbps. • Green—Link speed is 1 Gbps.

4	1-Gb Ethernet dedicated management link status	<ul style="list-style-type: none"> • Off—No link is present. • Green—Link is active. • Green, blinking—Traffic is present on the active link.
5	Rear unit identification	<ul style="list-style-type: none"> • Off—The unit identification function is not in use. • Blue, blinking—The unit identification function is activated.
6	Power supply status (one LED for each power supply unit)	<p>AC power supplies:</p> <ul style="list-style-type: none"> • Off—No AC input (12 V main power off, 12 V standby power off). • Green, blinking—12 V main power off; 12 V standby power on. • Green, solid—12 V main power on; 12 V standby power on. • Amber, blinking—Warning threshold detected, but 12 V main power on. • Amber, solid—Critical error detected; 12 V main power off (for example, over-current, over-voltage, or over-temperature failure). <p>DC power supplies:</p> <ul style="list-style-type: none"> • Off—No DC input (12 V main power off, 12 V standby power off). • Green, blinking—12 V main power off; 12 V standby power on. • Green, solid—12 V main power on; 12 V standby power on. • Amber, blinking—Warning threshold detected, but 12 V main power on. • Amber, solid—Critical error detected; 12 V main power off (for example, over-current, over-voltage, or over-temperature failure).

Internal Diagnostic LEDs

The server has internal fault LEDs for CPUs, DIMMs, and fan modules.

Figure 5: Internal Diagnostic LED Locations

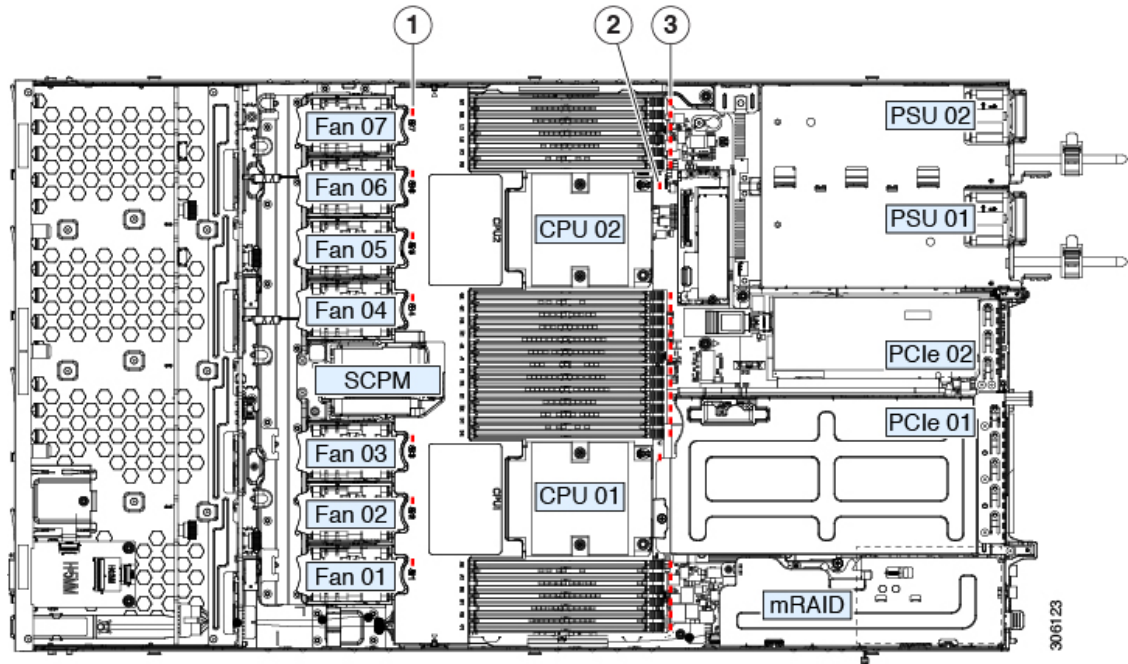

Fan module fault LEDs (one behind each fan connector on the motherboard)

- Amber—Fan has a fault or is not fully seated.
- Green—Fan is OK.

DIMM fault LEDs (one behind each DIMM socket on the motherboard)

These LEDs operate only when the server is in standby power mode.

- Amber—DIMM has a fault.
- Off—DIMM is OK.

CPU fault LEDs (one behind each CPU socket on the motherboard).

These LEDs operate only when the server is in standby power mode.

- Amber—CPU has a fault.
- Off—CPU is OK.

Serviceable Component Locations

This section describes the field-replaceable components and service related items. The view in the following figure shows the appliance with the top cover removed.

Figure 6: Serviceable Component Locations

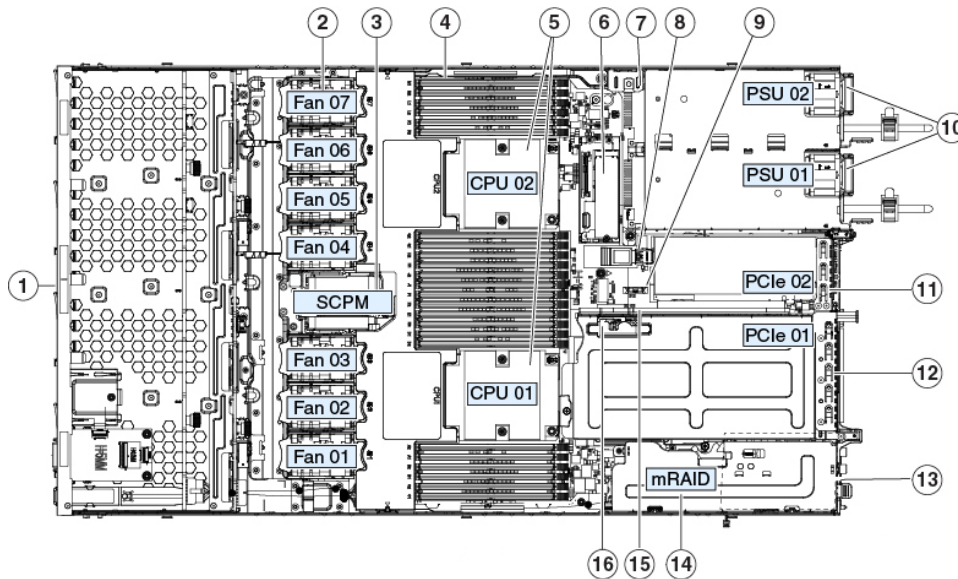

1 Front-loading drive bays 1–10 support SAS/SATA drives	9 RTC battery, vertical socket
2 Cooling fan modules (seven, hot-swappable)	10 Power supplies (hot-swappable when redundant as 1+1)
3 Supercap unit mounting bracket (RAID backup)	11 PCIe riser 2 or slot 2 (half-height, x16 lane) Includes PCIe cable connectors for front-loading NVMe SSDs (x8 lane)
4 DIMM sockets on motherboard (12 per CPU)	12 PCIe riser 1 or slot 1 (full-height, x16 lane) Includes socket for Micro-SD card
5 CPUs and heatsinks (up to two)	13 Modular LOM (mLOM) card bay on chassis floor (x16 PCIe lane), not visible in this view
6 Mini storage module socket Supports either an SD card module with two SD card slots; or an M.2 module with two NVMe or SATA M.2 SSD slots.	14 Modular RAID (mRAID) riser, can optionally be a riser that supports either: <ul style="list-style-type: none"> • Hardware RAID controller card • Interposer card for embedded SATA RAID
7 Chassis intrusion switch (optional)	15 PCIe cable connectors for front-loading NVMe SSDs on PCIe riser 2
8 Internal USB 3.0 port on motherboard	16 Micro-SD card socket on PCIe riser 1

Summary of Server Features

The following table lists a summary of server features.

Feature	Description
Chassis	One rack-unit (1RU) chassis
Central Processor	<ul style="list-style-type: none"> • Intel Xeon 2.1 GHz 4110 • Intel Xeon 2.1 GHz 4116
Memory	24 DDR4 DIMM sockets on the motherboard (12 each CPU)
Multi-bit error protection	Multi-bit error protection is supported
Baseboard management	<p>Board management controller (BMC), running Cisco Integrated Management Controller (Cisco IMC) firmware.</p> <p>Depending on your Cisco IMC settings, Cisco IMC can be accessed through the 1-Gb dedicated management port, the 1-Gb/10-Gb Ethernet LAN ports, or a Cisco virtual interface card.</p>
Network and management I/O	<p>Rear panel:</p> <ul style="list-style-type: none"> • One 1-Gb Ethernet dedicated management port (RJ-45 connector) • Two 1-Gb/10-Gb BASE-T Ethernet LAN ports (RJ-45 connectors) The dual LAN ports can support 1 Gbps or 10 Gbps depending on the link partner capability. • One RS-232 serial port (RJ-45 connector) • One Video Graphics Array (VGA) connector port (DB-15 connector) • Two USB 3.0 ports <p>Front panel:</p> <ul style="list-style-type: none"> • One front-panel keyboard/video/mouse (KVM) connector that is used with the KVM cable, which provides two USB 2.0, one VGA, and one DB-9 serial connector.
Modular LOM	One dedicated socket (x16 PCIe lane) that can be used to add an mLOM card for additional rear-panel connectivity.
WoL	The two 1-Gb/10-Gb BASE-T Ethernet LAN ports support the wake-on-LAN (WoL) standard.
Power	<p>Two power supplies, redundant as 1+1:</p> <ul style="list-style-type: none"> • AC power supplies 770 W AC each • AC power supplies 1050 W AC each • AC power supplies 1600 W AC each • DC power supplies 1050 W DC each <p>Do not mix power supply types or wattages in the server.</p>
ACPI	The advanced configuration and power interface (ACPI) 4.0 standard is supported.
Cooling	Seven hot-swappable fan modules for front-to-rear cooling.

Feature	Description
PCIe I/O	Two horizontal PCIe expansion slots on a PCIe riser assembly.
InfiniBand	The PCIe bus slots in this server support the InfiniBand architecture.
Storage, internal	<p>The following internal storage options are available:</p> <ul style="list-style-type: none"> • One USB port on the motherboard. • Mini-storage module socket, optionally with either: <ul style="list-style-type: none"> • SD card module. Supports up to two SD cards. • M.2 SSD module. Supports either two SATA M.2 SSDs or two NVMe M.2 SSDs. • One micro-SD card socket on PCIe riser 1.
Storage management	<p>The appliance has a dedicated internal mRAID riser that supports one of the following storage-controller options:</p> <ul style="list-style-type: none"> • A PCIe-style Cisco modular RAID controller card (SAS/SATA). • A PCIe-style interposer card for the server's embedded SATA RAID controller.
RAID backup	The appliance has a mounting bracket near the cooling fans for the supercap unit that is used with the Cisco modular RAID controller card.
Integrated video	Integrated VGA video.



CHAPTER 2

Installing the Appliance

- [Installation Warnings and Guidelines, on page 15](#)
- [Rack Requirements, on page 16](#)
- [Installing the Appliance in a Rack, on page 17](#)
- [Initial Setup, on page 21](#)
- [Updating the BIOS and Cisco IMC Firmware, on page 26](#)
- [Accessing the System BIOS, on page 26](#)
- [Smart Access Serial, on page 26](#)

Installation Warnings and Guidelines



Warning

IMPORTANT SAFETY INSTRUCTIONS

This warning symbol means danger. You are in a situation that could cause bodily injury. Before you work on any equipment, be aware of the hazards involved with electrical circuitry and be familiar with standard practices for preventing accidents. Use the statement number provided at the end of each warning to locate its translation in the translated safety warnings that accompanied this device.

Statement 1071



Warning

To prevent the system from overheating, do not operate it in an area that exceeds the maximum recommended ambient temperature of: 35° C (95° F).

Statement 1047



Warning

The plug-socket combination must be accessible at all times, because it serves as the main disconnecting device.

Statement 1019



Warning This product relies on the building's installation for short-circuit (overcurrent) protection. Ensure that the protective device is rated not greater than: 250 V, 15 A.

Statement 1005



Warning Installation of the equipment must comply with local and national electrical codes.

Statement 1074



Warning This unit is intended for installation in restricted access areas. A restricted access area can be accessed only through the use of a special tool, lock, and key, or other means of security.

Statement 1017



Caution Rack the appliance using rail kits to ensure proper airflow. Physically placing the units on top of one another or stacking without the use of the rail kits, blocks the air vents on the top, which could result in overheating, higher fan speeds, and higher power consumption. We recommend that you mount your appliance on rail kits while installing in the rack because these rails provide the minimal spacing required between the units. No additional spacing is required when you mount the units using rail kits.

Follow these guidelines while installing the appliance:

- Ensure that there is adequate space around the appliance to allow for easy access and for adequate airflow.
- Ensure that the air-conditioning meets the thermal requirements listed in the [Environmental Specifications, on page 29](#).
- Ensure that the cabinet or rack meets the requirements listed in the [Rack Requirements, on page 16](#).
- Ensure that the site power meets the power requirements listed in the [Power Specifications, on page 30](#). If available, you can use an uninterruptible power supply (UPS) to protect against power failures.

Rack Requirements

The rack must be of the following type:

- A standard 19-inch (48.3 cm) wide, four-post EIA rack, with mounting posts that conform to English universal hole spacing, per section 1 of ANSI/EIA-310-D-1992.
- The rack-post holes can be square 0.38 inch (9.6 mm), round 0.28 inch (7.1 mm), #12-24 UNC, or #10-32 UNC when you use the Cisco-supplied slide rails.
- The minimum vertical rack space per server must be one rack unit (RU), which is equal to 1.75 inch (44.45 mm).

Rack Installation Tools Required

The slide rails sold by Cisco Systems for this server do not require tools for installation.

Slide Rail and Cable Management Arm Dimensions

The slide rails have an adjustment range of 24 to 36 inches (610 to 914 mm).

The optional cable management arm (CMA) adds additional length requirements:

- The additional distance from the rear of the appliance to the rear of the CMA is 5.4 inches (137.4 mm).
- The total length of the appliance including the CMA is 35.2 inches (894 mm).

Installing the Appliance in a Rack



Warning

To prevent bodily injury when mounting or servicing this unit in a rack, you must take special precautions to ensure that the system remains stable. The following guidelines are provided to ensure your safety:

This unit should be mounted at the bottom of the rack if it is the only unit in the rack.

When mounting this unit in a partially filled rack, load the rack from the bottom to the top with the heaviest component at the bottom of the rack.

If the rack is provided with stabilizing devices, install the stabilizers before mounting or servicing the unit in the rack.

Statement 1006

Step 1

Attach the inner rails to the sides of the appliance:

- Align an inner rail with one side of the appliance so that the three keyed slots in the rail align with the three pegs on the side of the appliance.
- Set the keyed slots over the pegs, and then slide the rail toward the front to lock it in place on the pegs. The front slot has a metal clip that locks over the front peg.
- Install the second inner rail to the opposite side of the appliance.

Figure 7: Attaching the Inner Rail to the Side of the Appliance

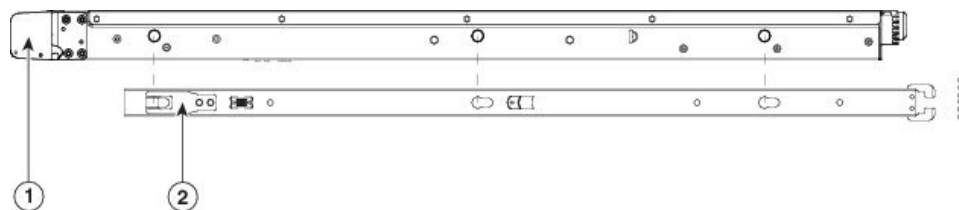

Front of appliance	Locking clip on front of inner rail
--------------------	-------------------------------------

Step 2 Open the front securing plate on both slide-rail assemblies. The front end of the slide-rail assembly has a spring-loaded securing plate that must be open before you can insert the mounting pegs into the rack-post holes.

On the outside of the assembly, push the green-arrow button toward the rear to open the securing plate.

Figure 8: Front Securing Mechanism, Inside of Front End

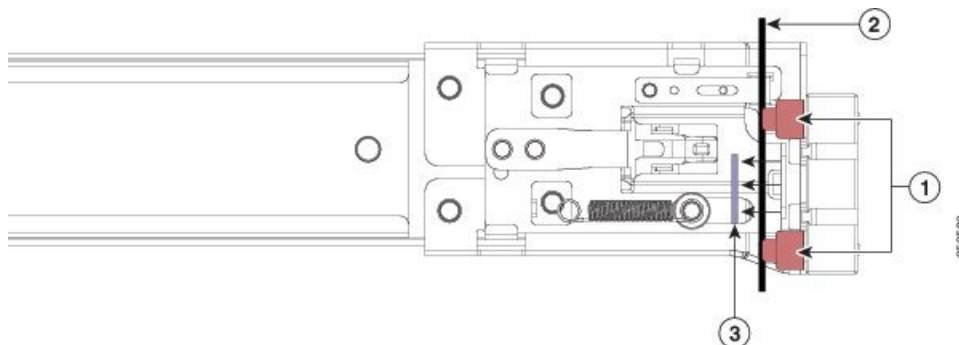

Front mounting pegs	Securing plate shown pulled back to the open position
Rack post between mounting pegs and opened securing plate	-

Step 3 Install the outer slide rails into the rack:

- a) Align one slide-rail assembly front end with the front rack-post holes that you want to use.

The slide rail front-end wraps around the outside of the rack post and the mounting pegs enter the rack-post holes from the outside-front.

Note The rack post must be between the mounting pegs and the open securing plate.

- b) Push the mounting pegs into the rack-post holes from the outside-front.
 c) Press the securing plate release button, marked **Push**. The spring-loaded securing plate closes to lock the pegs in place.
 d) Adjust the slide-rail length, and then push the rear mounting pegs into the corresponding rear rack-post holes.
 The rear mounting pegs enter the rear rack-post holes from the inside of the rack post.
 e) Attach the second slide-rail assembly to the opposite side of the rack. Ensure that the two slide-rail assemblies are at the same height and are level front-to-back.
 f) Pull the inner slide rails on each assembly out toward the rack front until they hit the internal stops and lock in place.

Step 4 Insert the appliance into the slide rails:

Caution This appliance can weigh up to 60 pounds (27 kilograms) when fully loaded with components. We recommend that you use a minimum of two people or a mechanical lift when lifting the server. Attempting this procedure alone could result in personal injury or equipment damage.

- a) Align the rear ends of the inner rails that are attached to the appliance sides with the front ends of the empty slide rails on the rack.
 b) Push the inner rails into the slide rails on the rack until they stop at the internal stops.
 c) Slide the inner-rail release clip toward the rear on both inner rails, and then continue pushing the appliance into the rack until its front slam-latches engage with the rack posts.

Figure 9: Inner-Rail Release Clip

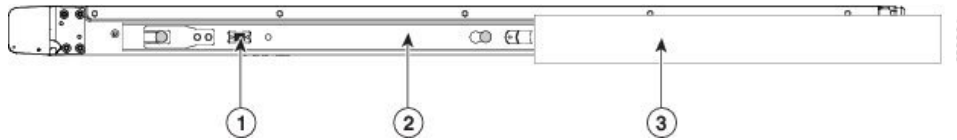

1 Inner-rail release clip	3 Outer slide rail attached to rack post
2 Inner rail attached to appliance and inserted into outer slide rail	-

Step 5 (Optional) Secure the appliance in the rack by using the two screws that are provided with the slide rails. Perform this step if you plan to move the rack with appliance installed.

With the appliance fully pushed into the slide rails, open a hinged slam latch lever on the front of the appliance and insert a screw through the hole that is under the lever. The screw threads into the static part of the rail on the rack post and prevents the server from being pulled out. Repeat for the opposite slam latch.

Installing the Cable Management Arm (Optional)



Note The cable management arm (CMA) is reversible left-to-right. To reverse the CMA, see [Reversing the Cable Management Arm \(Optional\)](#), on page 20 before installation.

Step 1 With the appliance pushed fully into the rack, slide the CMA tab of the CMA arm that is farthest from the appliance onto the end of the stationary slide rail that is attached to the rack post. Slide the tab over the end of the rail until it clicks and locks.

Figure 10: Attaching the CMA to the Rear Ends of the Slide Rails

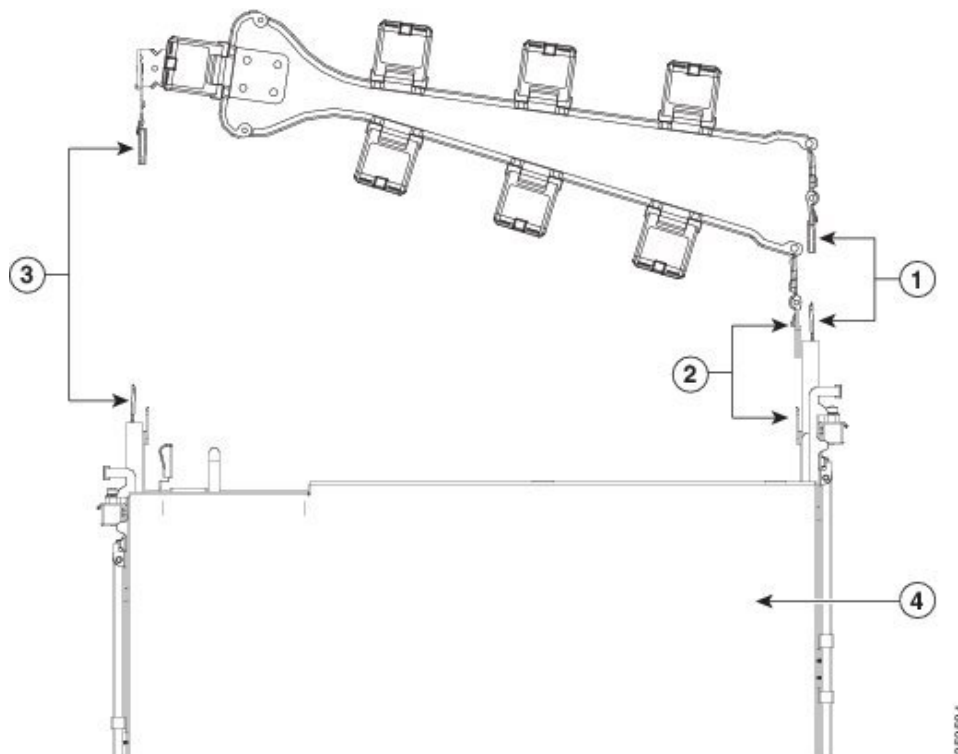

<p>③ CMA tab on arm farthest from appliance attaches to end of stationary outer slide rail.</p>	<p>① CMA tab on width-adjustment slider attaches to end of stationary outer slide rail.</p>
<p>② CMA tab on arm closest to the appliance attaches to end of inner slide rail attached to appliance.</p>	<p>④ Rear of appliance</p>

- Step 2** Slide the CMA tab that is closest to the appliance over the end of the inner rail that is attached to the appliance. Slide the tab over the end of the rail until it clicks and locks.
- Step 3** Pull out the width-adjustment slider that is at the opposite end of the CMA assembly until it matches the width of your rack.
- Step 4** Slide the CMA tab that is at the end of the width-adjustment slider onto the end of the stationary slide rail that is attached to the rack post. Slide the tab over the end of the rail until it clicks and locks.
- Step 5** Open the hinged flap at the top of each plastic cable guide and route your cables through the cable guides as desired.

Reversing the Cable Management Arm (Optional)

- Step 1** Rotate the entire Cable Management Arm (CMA) assembly 180 degrees, left-to-right. The plastic cable guides must remain pointing upward.
- Step 2** Flip the tabs at the ends of the CMA arms so that they point toward the rear of the appliance.

- Step 3** Pivot the tab that is at the end of the width-adjustment slider. Depress and hold the metal button on the outside of the tab and pivot the tab 180 degrees so that it points toward the rear of the appliance.

Figure 11: Reversing the CMA

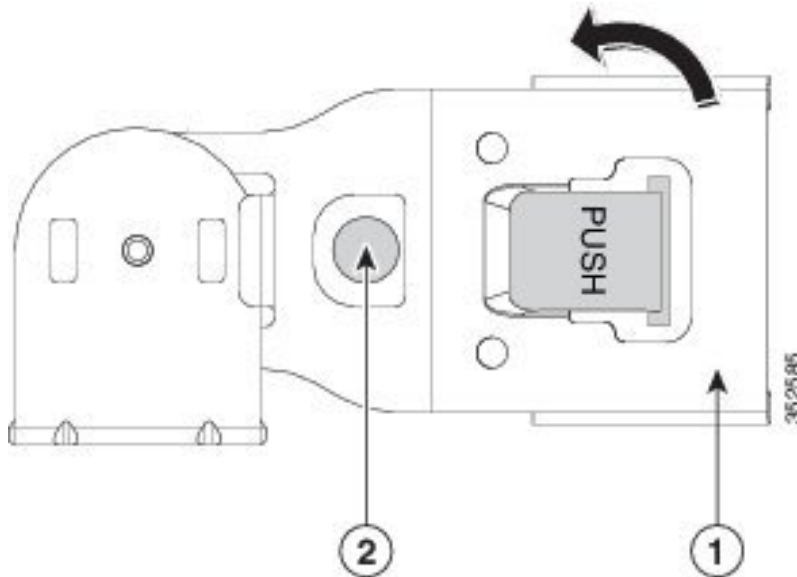

2 CMA tab on end of width-adjustment slider

1 Metal button on outside of tab

Initial Setup



Note This section describes how to connect to the system for initial setup.

Appliance Default Settings

The appliance is shipped with the following default settings:

- The NIC mode is *Shared LOM EXT*.

Shared LOM EXT mode enables the 1-Gb/10-Gb Ethernet ports and the ports on any installed Cisco virtual interface card (VIC) to access the Cisco IMC. If you want to use the 10/100/1000 dedicated management ports to access Cisco IMC, you can change the NIC mode as described in [Setting Up the System With the Cisco IMC Configuration Utility, on page 24](#).

- The NIC redundancy is *Active-Active*. All Ethernet ports are utilized simultaneously.
- DHCP is enabled.
- IPv4 is enabled.

Connection Methods

There are two methods for connecting to the system for initial setup:

- Local setup—Use this procedure if you want to connect a keyboard and monitor directly to the system for setup. This procedure can use a KVM cable (Cisco PID N20-BKVM) or the ports on the rear of the appliance.
- Remote setup—Use this procedure if you want to perform setup through your dedicated management LAN.



Note To configure the system remotely, you must have a DHCP server on the same network as the system. Your DHCP server must be preconfigured with the range of MAC addresses for this server node. The MAC address is printed on a label that is on the pull-out asset tag on the front panel. This server node has a range of six MAC addresses assigned to the Cisco IMC. The MAC address printed on the label is the beginning of the range of six contiguous MAC addresses.

Connecting to the Appliance Locally For Setup

This procedure requires the following equipment:

- VGA monitor
- USB keyboard
- One of the following:
 - Supported Cisco KVM cable (Cisco PID N20-BKVM)
 - USB cable and VGA DB-15 cable

Step 1 Attach a power cord to each power supply in your appliance, and then attach each power cord to a grounded power outlet.

Wait for approximately two minutes to let the appliance boot to standby power during the first bootup. You can verify system power status by looking at the system Power Status LED on the front panel. The system is in standby power mode when the LED is amber.

Step 2 Connect a USB keyboard and VGA monitor to the appliance using one of the following methods:

- Connect an optional KVM cable (Cisco PID N20-BKVM) to the KVM connector on the front panel. Connect your USB keyboard and VGA monitor to the KVM cable.
- Connect a USB keyboard and VGA monitor to the corresponding connectors on the rear panel.

Step 3 Open the Cisco IMC Configuration Utility:

- Press and hold the front panel power button for four seconds to boot the appliance.
- During bootup, press **F8** when prompted to open the Cisco IMC Configuration Utility.

Note When you open the Cisco IMC Configuration Utility for the first time, you are prompted to change the default password. The default password is *password*. The Strong Password feature is enabled.

The following are the requirements for Strong Password:

- The password can have a minimum of 8 characters and maximum 14 characters.
- The password must not contain the user's name.
- The password must contain characters from three of the following categories:
 - English uppercase letters (A through Z)
 - English lowercase letters (a through z)
 - Base 10 digits (0 through 9)
 - Non-alphabetic characters !, @, #, \$, %, ^, &, *, -, _, =, “

Step 4 Continue with [Setting Up the System With the Cisco IMC Configuration Utility, on page 24](#).

Connecting to the Appliance Remotely For Setup

This procedure requires the following equipment:

- One RJ-45 Ethernet cable that is connected to your management LAN.



Note To configure the system remotely, you must have a DHCP server on the same network as the system. Your DHCP server must be preconfigured with the range of MAC addresses for this server node. The MAC address is printed on a label that is on the pull-out asset tag on the front panel. This server node has a range of six MAC addresses assigned to the Cisco IMC. The MAC address printed on the label is the beginning of the range of six contiguous MAC addresses.

Step 1 Attach a power cord to each power supply in your appliance, and then attach each power cord to a grounded power outlet. Wait for approximately two minutes to let the appliance boot to standby power during the first bootup. You can verify system power status by looking at the system Power Status LED on the front panel. The system is in standby power mode when the LED is amber.

Step 2 Plug your management Ethernet cable into the dedicated management port on the rear panel.

Step 3 Allow your preconfigured DHCP server to assign an IP address to the server node.

Step 4 Use the assigned IP address to access and log in to the Cisco IMC for the server node.

Note The default user name for the server is *admin*. The default password is *password*.

Step 5 From the Cisco IMC Server Summary page, click **Launch KVM Console**.

A separate KVM console window opens.

Step 6 From the Cisco IMC Summary page, click **Power Cycle Server**.

The system reboots.

Step 7 Select the KVM console window.

Step 8 When prompted, press **F8** to enter the Cisco IMC Configuration Utility.

Note When you open the Cisco IMC Configuration Utility for the first time, you are prompted to change the default password. The default password is *password*. The Strong Password feature is enabled.

The following are the requirements for Strong Password:

- The password can have a minimum of 8 characters and maximum 14 characters.
- The password must not contain the user's name.
- The password must contain characters from three of the following categories:
 - English uppercase letters (A through Z)
 - English lowercase letters (a through z)
 - Base 10 digits (0 through 9)
 - Non-alphabetic characters !, @, #, \$, %, ^, &, *, -, _, =, “

Step 9 Continue with [Setting Up the System With the Cisco IMC Configuration Utility, on page 24](#).

Setting Up the System With the Cisco IMC Configuration Utility

Before you begin

The following procedure is performed after you connect to the system and open the Cisco IMC Configuration Utility.



Note You must use the versions of Cisco IMC firmware from the Cisco ISE download site, which are qualified versions for use with the SNS hardware appliances. Versions of Cisco IMC for UCS are not compatible. Newer versions of Cisco IMC are developed for SNS hardware appliances after they are developed for UCS.

Step 1 Set the NIC mode to choose which ports to use to access Cisco IMC for server management:

- *Shared LOM EXT* (default)—This is the shared LOM extended mode, the factory-default setting. With this mode, the Shared LOM and Cisco Card interfaces are both enabled. If you select this option, you must select the default *Active-Active* NIC redundancy setting in the following step.
- *Shared LOM*—The 1-Gb/10-Gb Ethernet ports are used to access Cisco IMC. If you select this option, you must select *Active-Active* or *Active-standby* NIC redundancy setting in the following step.
- *Dedicated*—The dedicated management port is used to access Cisco IMC. If you select this option, you must select the *None* NIC redundancy setting in the following step.
- *Cisco Card*—The Virtual Interface Card (VIC) ports are used to access the Cisco IMC. If you select this option, you must select *Active-Active* or *Active-standby* NIC redundancy setting in the following step.

- **VIC Slot**—Only if you use the Cisco Card NIC mode, you must select this setting to match where your VIC is installed. You can select Riser1, Riser2, or Flex-LOM (the mLOM slot).
 - If you select Riser1, you must install the VIC in slot 1.
 - If you select Riser2, you must install the VIC in slot 2.
 - If you select Flex-LOM, you must install an mLOM-style VIC in the mLOM slot.

Step 2 Choose one of the following options for NIC redundancy:

- **None**—The Ethernet ports operate independently and do not fail over if there is a problem. This setting can be used only with the Dedicated NIC mode.
- **Active-standby**—If an active Ethernet port fails, traffic fails over to a standby port. Shared LOM and Cisco Card modes can use *Active-standby* or *Active-active* settings.
- **Active-active (default)**—All Ethernet ports are used simultaneously. You must use only this NIC redundancy setting if you have selected the Shared LOM EXT mode. Shared LOM and Cisco Card modes can use *Active-standby* or *Active-active* settings.

Step 3 Choose whether to enable DHCP for dynamic network settings, or to enter static network settings.

Note Before you enable DHCP, you must preconfigure your DHCP server with the range of MAC addresses for this server. The MAC address is printed on a label on the rear of the server. This server has a range of six MAC addresses assigned to Cisco IMC. The MAC address printed on the label is the beginning of the range of six contiguous MAC addresses.

The **Static IPv4 and IPv6 Settings** include the following:

- **Cisco IMC IP address**—For IPv6, valid values are 1 - 127.
- **Gateway**—For IPv6, if you do not know the gateway, you can set it as none by entering :: (two colons).
- **Preferred DNS Server Address**—For IPv6, you can set this as none by entering :: (two colons).

Step 4 (Optional) Configure VLAN settings.

Step 5 (Optional) Set a hostname for the server.

Step 6 (Optional) Enable dynamic DNS and set a dynamic DNS (DDNS) domain.

Step 7 (Optional) If you check the **Factory Default** check box, the server reverts to the factory defaults.

Step 8 (Optional) Set a default user password.

Note The factory default username for the server is *admin*. The default password is *password*.

Step 9 (Optional) Enable auto-negotiation of port settings or set the port speed and duplex mode manually.

Note Auto-negotiation is applicable only when you use the Dedicated NIC mode. Auto-negotiation sets the port speed and duplex mode automatically based on the switch port to which the server is connected. If you disable auto-negotiation, you must set the port speed and duplex mode manually.

Step 10 (Optional) Reset port profiles and the port name.

Step 11 Press **F5** to refresh the settings that you made. You might have to wait about 45 seconds until the new settings appear and the message, “Network settings configured” is displayed before you reboot the server in the next step.

Step 12 Press **F10** to save your settings and reboot the server.

Note If you chose to enable DHCP, the dynamically assigned IP and MAC addresses are displayed during bootup.

Updating the BIOS and Cisco IMC Firmware



Caution When you upgrade the BIOS firmware, you must also upgrade the Cisco IMC firmware to the corresponding version or the server will not boot. It is possible to have the Cisco IMC firmware and the BIOS firmware running on different versions.

The server uses firmware obtained from and certified by Cisco. Cisco provides release notes with each firmware image.

You can upgrade the Cisco IMC and BIOS firmware by using the Cisco IMC GUI or CLI interface.



Note Since Adobe Flash Player is End of Life and not supported in any browser, use the Cisco IMC command line interface and SFTP as the remote server to download the Cisco IMC or BIOS firmware, in case a flash player is required. This can also be used to overcome the file size limit of 40MB.

Accessing the System BIOS

Step 1 Enter the BIOS Setup Utility by pressing the **F2** key when prompted during bootup.

Note The version and build of the current BIOS are displayed on the Main page of the utility.

Step 2 Use the arrow keys to select the BIOS menu page.

Step 3 Highlight the field to be modified by using the arrow keys.

Step 4 Press **Enter** to select the field that you want to change, and then modify the value in the field.

Step 5 Press the right arrow key until the Exit menu screen is displayed.

Step 6 Follow the instructions on the Exit menu screen to save your changes and exit the setup utility (or press **F10**). You can exit without saving changes by pressing **Esc**.

Smart Access Serial

This server supports the Smart Access Serial feature. This feature allows you to switch between host serial and Cisco IMC CLI.

- This feature has the following requirements:

- A serial cable connection, which can use the RJ-45 serial connector on the server rear panel, or a DB-9 connection when using the KVM cable (Cisco PID N20-BKVM) on the front-panel KVM console connector.
 - Console redirection must be enabled in the server BIOS.
 - Terminal type must be set to VT100+ or VTUFT8.
 - Serial-over-LAN (SOL) must be disabled to use the serial port to install Cisco ISE, if KVM is not available.
- To switch from host serial to Cisco IMC CLI, press **Esc+9**.
You must enter your Cisco IMC credentials to authenticate the connection.
 - To switch from Cisco IMC CLI to host serial, press **Esc+8**.



Note You cannot switch to Cisco IMC CLI if the serial-over-LAN (SOL) feature is enabled.

- After a session is created, it is shown in the CLI or web GUI by the name `serial`.



CHAPTER 3

Server Specifications

- [Server Specifications](#), on page 29
- [Power Specifications](#), on page 30
- [Power Cord Specifications](#), on page 33

Server Specifications

This chapter lists the physical, environmental, and power specifications for the server.

Physical Specifications

The following table lists the physical specifications for the server.

Table 4: Physical Specifications

Description	Specification
Height	1.7 in. (43.2 mm)
Width	16.9 in. (429.0 mm)
Depth (length)	Server only: 29.5 in. (740.3 mm) Server with slide rail: 31.0 in. (787.4 mm)
Weight	Maximum: 37.5 lb. (17.0 Kg) Minimum: 29.0 lb. (13.2 Kg)

Environmental Specifications

The following table lists the environmental requirements and specifications for the server.

Table 5: Environmental Specifications

Description	Specification
-------------	---------------

Temperature, operating	41 to 95°F (5 to 35°C) Derate the maximum temperature by 1°C per every 305 meters of altitude above sea level.
Temperature, Non-operating (when the server is stored or transported)	−40 to 149°F (−40 to 65°C)
Humidity (RH), operating	10 to 90%
Humidity (RH), non-operating (when the server is stored or transported)	5 to 93%
Altitude, operating	0 to 10,000 feet
Altitude, non-operating (when the server is stored or transported)	0 to 40,000 feet
Sound power level Measure A-weighted per ISO7779 LwAd (Bels) Operation at 73°F (23°C)	5.5
Sound pressure level Measure A-weighted per ISO7779 LpAm (dBA) Operation at 73°F (23°C)	40

Power Specifications



Note Do not mix power supply types or wattages. Both power supplies must be identical.

The power specifications for the supported power supply options are listed in the following sections.

770 W AC Power Supply

This section lists the specifications for each 770 W AC power supply.

Table 6: 770 W AC Specifications

Description	Specification
AC Input Voltage	Nominal range: 100–120 VAC, 200–240 VAC (Range: 90–132 VAC, 180–264 VAC)

AC Input Frequency	Nominal range: 50 to 60Hz (Range: 47–63 Hz)
Maximum AC Input current	9.5 A at 100 VAC 4.5 A at 208 VAC
Maximum input volt-amperes	950 VA at 100 VAC
Maximum inrush current	15 A (sub-cycle duration)
Maximum hold-up time	12 ms at 770 W
Maximum output power per PSU	770 W
Power supply output voltage	12 VDC
Power supply standby voltage	12 VDC
Efficiency rating	Climate Savers Platinum Efficiency (80Plus Platinum certified)
Form factor	RSP2
Input connector	IEC320 C14

1050 W AC Power Supply

This section lists the specifications for each 1050 W AC power supply.

Table 7: 1050 W AC Specifications

Description	Specification
AC Input Voltage	Nominal range: 100–120 VAC, 200–240 VAC (Range: 90–132 VAC, 180–264 VAC)
AC Input Frequency	Nominal range: 50 to 60Hz (Range: 47–63 Hz)
Maximum AC Input current	12.5 A at 100 VAC 6.0 A at 208 VAC
Maximum input volt-amperes	1250 VA at 100 VAC
Maximum inrush current	15 A (sub-cycle duration)
Maximum hold-up time	12 ms at 1050 W
Maximum output power per PSU	800 W at 100–120 VAC 1050 W at 200–240 VAC

Power supply output voltage	12 VDC
Power supply standby voltage	12 VDC
Efficiency rating	Climate Savers Platinum Efficiency (80Plus Platinum certified)
Form factor	RSP2
Input connector	IEC320 C14

1600 W AC Power Supply

This section lists the specifications for each 1600 W AC power supply.

Table 8: 1600 W AC Specifications

Description	Specification
AC Input Voltage	Nominal range: 200–240 VAC (Range: 180–264 VAC)
AC Input Frequency	Nominal range: 50 to 60Hz (Range: 47–63 Hz)
Maximum AC Input current	9.5 A at 200 VAC
Maximum input volt-amperes	1250 VA at 200 VAC
Maximum inrush current	30 A at 35° C
Maximum hold-up time	80 ms at 1600 W
Maximum output power per PSU	1600 W at 200–240 VAC
Power supply output voltage	12 VDC
Power supply standby voltage	12 VDC
Efficiency rating	Climate Savers Platinum Efficiency (80Plus Platinum certified)
Form factor	RSP2
Input connector	IEC320 C14

1050 W DC Power Supply

This section lists the specifications for each 1050 W DC power supply.

Table 9: 1050 W DC Specifications

Description	Specification
-------------	---------------

DC Input Voltage	Nominal range: -48 to -60 VDC (Range: -40 to -72 VDC)
Maximum DC input current	32 A at -40 VDC
Maximum input wattage	1234 W
Maximum inrush current	35 A (sub-cycle duration)
Maximum hold-up time	5 ms at 100% load (1050 W main and 36 W standby)
Maximum output power per PSU	1050 W on 12 VDC main power 36 W on 12 VDC standby power
Power supply output voltage	12 VDC
Power supply standby voltage	12 VDC
Efficiency rating	≥ 92% at 50% load
Form factor	RSP2
Input connector	Fixed 3-wire block

Power Cord Specifications

Each power supply in the appliance has a power cord. Standard power cords or jumper power cords are available for connection to the appliance. The shorter jumper power cords, for use in racks, are available as an optional alternative to the standard power cords.



Note Only the approved power cords or jumper power cords listed below are supported.

Table 10: Supported Power Cords

Description	Length (Feet)	Length (Meters)
CAB-48DC-40A-8AWG DC power cord, -48 VDC, 40 A, 8 AWG Three-socket Mini-Fit connector to three-wire	11.7	3.5
CAB-C13-C14-AC AC power cord, 10 A; C13 to C14, recessed receptacle	9.8	3.0

CAB-250V-10A-AR AC power cord, 250 V, 10 A (Argentina)	8.2	2.5
CAB-C13-C14-2M-JP AC Power Cord, C13 to C14 (Japan PSE Mark)	6.6	2.0
CAB-9K10A-EU AC Power Cord, 250 V, 10 A; CEE 7/7 Plug (Europe)	8.2	2.5
CAB-250V-10A-IS AC Power Cord, 250 V, 10 A (Israel)	8.2	2.5
CAB-250V-10A-CN AC power cord, 250 V, 10 A (PR China)	8.2	2.5
CAB-ACTW AC power cord, 250 V, 10 A (Taiwan)	7.5	2.3
CAB-C13-CBN AC cabinet jumper power cord, 250, 10 A, C13 to C14	2.2	0.68
CAB-C13-C14-2M AC cabinet jumper power cord, 250 V, 10 A, C13 to C14	6.6	2.0
CAB-9K10A-AU AC power cord, 250 V, 10 A, 3112 plug (Australia)	8.2	2.5
CAB-N5K6A-NA AC power cord, 200/240 V, 6 A (North America)	8.2	2.5

CAB-250V-10A-ID AC power Cord, 250 V, 10 A (India)	8.2	2.5
CAB-9K10A-SW AC power cord, 250 V, 10 A, MP232 plug (Switzerland)	8.2	2.5
CAB-250V-10A-BR AC power Cord, 250 V, 10 A (Brazil)	8.2	2.5
CAB-9K10A-UK AC power cord, 250 V, 10 A (13 A fuse), BS1363 plug (United Kingdom)	8.2	2.5
CAB-9K12A-NA AC power cord, 125 V, 13 A, NEMA 5-15 plug (North America)	8.2	2.5
CAB-AC-L620-C13 AC power cord, NEMA L6-20 to C13 connectors	6.6	2.0
CAB-9K10A-IT AC power cord, 250 V, 10 A, CEI 23-16/VII plug (Italy)	8.2	2.5
R2XX-DMYMPWRCORD No power cord	NA	NA

