



VXLAN Interfaces

This chapter tells how to configure Virtual eXtensible LAN (VXLAN) interfaces. VXLANs act as Layer 2 virtual networks over Layer 3 physical networks to stretch Layer 2 networks.

- [About VXLAN Interfaces, on page 1](#)
- [Requirements and Prerequisites for VXLAN Interfaces, on page 10](#)
- [Guidelines for VXLAN Interfaces, on page 10](#)
- [Default Settings for VXLAN Interfaces, on page 11](#)
- [Configure VXLAN Interfaces, on page 11](#)
- [Configure Geneve Interfaces, on page 17](#)
- [Allow Gateway Load Balancer Health Checks, on page 20](#)
- [Monitoring VXLAN Interfaces, on page 22](#)
- [Examples for VXLAN Interfaces, on page 24](#)
- [History for VXLAN Interfaces, on page 28](#)

About VXLAN Interfaces

VXLAN provides the same Ethernet Layer 2 network services as VLAN does, but with greater extensibility and flexibility. Compared to VLAN, VXLAN offers the following benefits:

- Flexible placement of multitenant segments throughout the data center.
- Higher scalability to address more Layer 2 segments: up to 16 million VXLAN segments.

This section describes how VXLAN works. For detailed information about VXLAN, see RFC 7348. For detailed information about Geneve, see RFC 8926.

Encapsulation

The ASA supports two types of VXLAN encapsulation:

- **VXLAN (all models)**—VXLAN uses MAC Address-in-User Datagram Protocol (MAC-in-UDP) encapsulation. The original Layer 2 frame has a VXLAN header added and is then placed in a UDP-IP packet.
- **Geneve (ASA virtual only)**—Geneve has a flexible inner header that is not limited to the MAC address. Geneve encapsulation is required for transparent routing of packets between an Amazon Web Services (AWS) Gateway Load Balancer and appliances, and for sending extra information.

VXLAN Tunnel Endpoint

VXLAN tunnel endpoint (VTEP) devices perform VXLAN encapsulation and decapsulation. Each VTEP has two interface types: one or more virtual interfaces called VXLAN Network Identifier (VNI) interfaces to which you apply your security policy, and a regular interface called the VTEP source interface that tunnels the VNI interfaces between VTEPs. The VTEP source interface is attached to the transport IP network for VTEP-to-VTEP communication.

The following figure shows two ASAs and Virtual Server 2 acting as VTEPs across a Layer 3 network, extending the VNI 1, 2, and 3 networks between sites. The ASAs act as bridges or gateways between VXLAN and non-VXLAN networks.

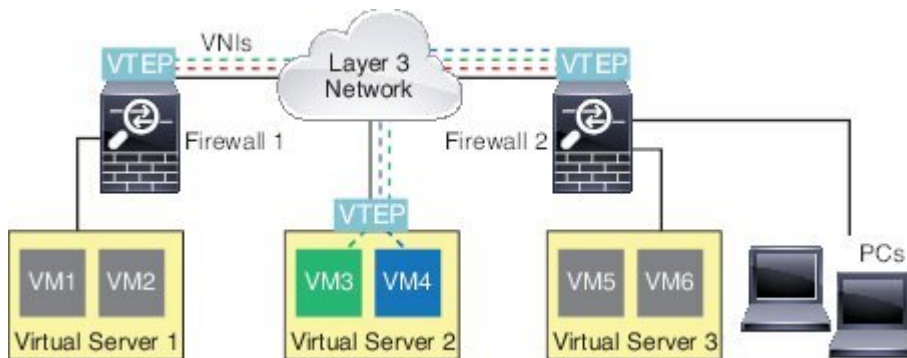

The underlying IP network between VTEPs is independent of the VXLAN overlay. Encapsulated packets are routed based on the outer IP address header, which has the initiating VTEP as the source IP address and the terminating VTEP as the destination IP address. For VXLAN encapsulation: The destination IP address can be a multicast group when the remote VTEP is not known. With Geneve, the ASA only supports static peers. The destination port for VXLAN is UDP port 4789 by default (user configurable). The destination port for Geneve is 6081.

VTEP Source Interface

The VTEP source interface is a regular ASA interface (physical, EtherChannel, or even VLAN) with which you plan to associate all VNI interfaces. You can configure one VTEP source interface per ASA/security context. Because you can only configure one VTEP source interface, you cannot configure both VXLAN and Geneve interfaces on the same device. There is an exception for ASA virtual clustering on AWS or Azure, where you can have two VTEP source interfaces: a VXLAN interface is used for the cluster control link, and a Geneve (AWS) or VXLAN (Azure) interface can be used for the Gateway Load Balancer.

The VTEP source interface can be devoted wholly to VXLAN traffic, although it is not restricted to that use. If desired, you can use the interface for regular traffic and apply a security policy to the interface for that traffic. For VXLAN traffic, however, all security policy must be applied to the VNI interfaces. The VTEP interface serves as a physical port only.

In transparent firewall mode, the VTEP source interface is not part of a BVI, and you do configure an IP address for it, similar to the way the management interface is treated.

VNI Interfaces

VNI interfaces are similar to VLAN interfaces: they are virtual interfaces that keep network traffic separated on a given physical interface by using tagging. You apply your security policy directly to each VNI interface.

You can only add one VTEP interface, and all VNI interfaces are associated with the same VTEP interface. There is an exception for ASA virtual clustering on AWS or Azure. For AWS clustering, you can have two VTEP source interfaces: a VXLAN interface is used for the cluster control link, and a Geneve interface can be used for the AWS Gateway Load Balancer. For Azure clustering, you can have two VTEP source interfaces: a VXLAN interface is used for the cluster control link, and a second VXLAN interface can be used for the Azure Gateway Load Balancer.

VXLAN Packet Processing

VXLAN

Traffic entering and exiting the VTEP source interface is subject to VXLAN processing, specifically encapsulation or decapsulation.

Encapsulation processing includes the following tasks:

- The VTEP source interface encapsulates the inner MAC frame with the VXLAN header.
- The UDP checksum field is set to zero.
- The Outer frame source IP is set to the VTEP interface IP.
- The Outer frame destination IP is decided by a remote VTEP IP lookup.

Decapsulation; the ASA only decapsulates a VXLAN packet if:

- It is a UDP packet with the destination port set to 4789 (this value is user configurable).
- The ingress interface is the VTEP source interface.
- The ingress interface IP address is the same as the destination IP address.
- The VXLAN packet format is compliant with the standard.

Geneve

Traffic entering and exiting the VTEP source interface is subject to Geneve processing, specifically encapsulation or decapsulation.

Encapsulation processing includes the following tasks:

- The VTEP source interface encapsulates the inner MAC frame with the Geneve header.
- The UDP checksum field is set to zero.
- The Outer frame source IP is set to the VTEP interface IP.
- The Outer frame destination IP is set the peer IP address that you configured.

Decapsulation; the ASA only decapsulates a Geneve packet if:

- It is a UDP packet with the destination port set to 6081 (this value is user configurable).
- The ingress interface is the VTEP source interface.
- The ingress interface IP address is the same as the destination IP address.
- The Geneve packet format is compliant with the standard.

Peer VTEP

When the ASA sends a packet to a device behind a peer VTEP, the ASA needs two important pieces of information:

- The destination MAC address of the remote device
- The destination IP address of the peer VTEP

The ASA maintains a mapping of destination MAC addresses to remote VTEP IP addresses for the VNI interfaces.

VXLAN Peer

There are two ways in which the ASA can find this information:

- A single peer VTEP IP address can be statically configured on the ASA.

You cannot manually define multiple peers.

For IPv4: The ASA then sends a VXLAN-encapsulated ARP broadcast to the VTEP to learn the end node MAC address.

For IPv6: The ASA then sends an IPv6 Neighbor Solicitation message to the IPv6 solicited-node multicast address. The peer VTEP responds with an IPv6 Neighbor Advertisement message with its link-local address.

- A multicast group can be configured on each VNI interface (or on the VTEP as a whole).



Note This option is not supported with Geneve.

For IPv4: The ASA sends a VXLAN-encapsulated ARP broadcast packet within an IP multicast packet through the VTEP source interface. The response to this ARP request enables the ASA to learn both the remote VTEP IP address along with the destination MAC address of the remote end node.

For IPv6: The ASA sends a Multicast Listener Discovery (MLD) Report message through the VTEP source interface to indicate that the ASA is listening on the VTEP interface for the multicast address traffic.

Geneve Peer

The ASA virtual only supports statically defined peers. You can define the ASA virtual peer IP address on the AWS Gateway Load Balancer. Because the ASA virtual never initiates traffic to the Gateway Load Balancer, you do not also have to specify the Gateway Load Balancer IP address on the ASA virtual; it learns the peer IP address when it receives Geneve traffic. Multicast groups are not supported with Geneve.

VXLAN Use Cases

This section describes the use cases for implementing VXLAN on the ASA.

VXLAN Bridge or Gateway Overview

Each ASA VTEP acts as a bridge or gateway between end nodes such as VMs, servers, and PCs and the VXLAN overlay network. For incoming frames received with VXLAN encapsulation over the VTEP source interface, the ASA strips out the VXLAN header and forwards it to a physical interface connected to a non-VXLAN network based on the destination MAC address of the inner Ethernet frame.

The ASA always processes VXLAN packets; it does not just forward VXLAN packets untouched between two other VTEPs.

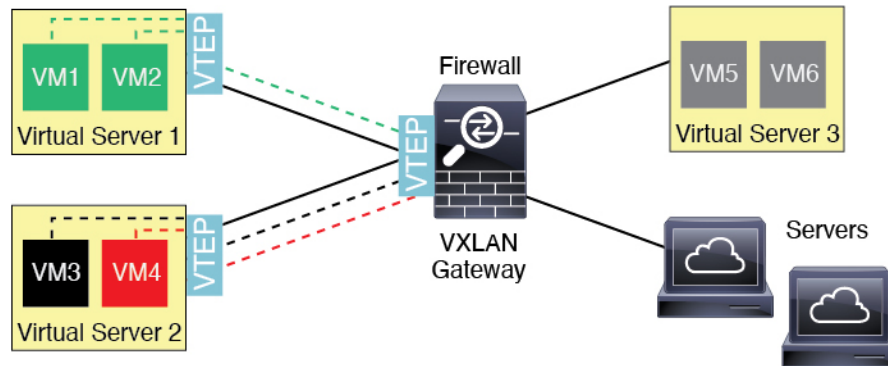

VXLAN Bridge

When you use a bridge group (transparent firewall mode, or optionally routed mode), the ASA can serve as a VXLAN bridge between a (remote) VXLAN segment and a local segment where both are in the same network. In this case, one member of the bridge group is a regular interface while the other member is a VNI interface.

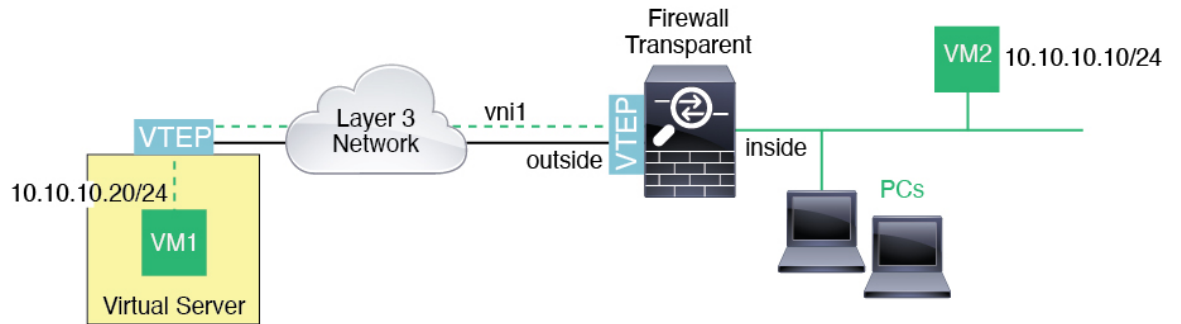

VXLAN Gateway (Routed Mode)

The ASA can serve as a router between VXLAN and non-VXLAN domains, connecting devices on different networks.

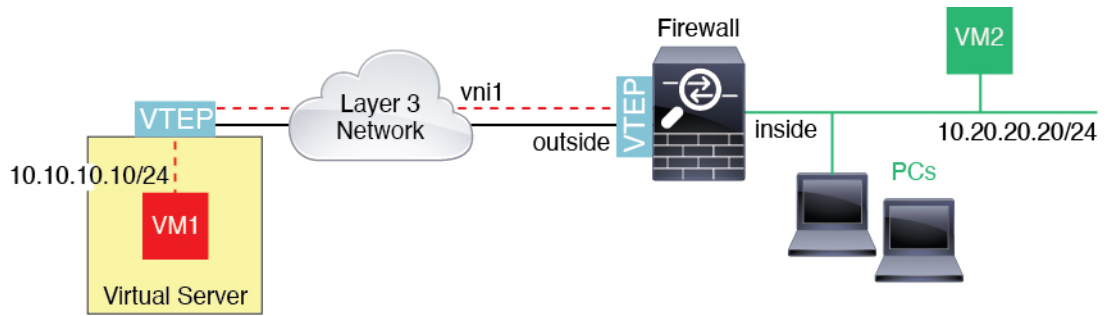

Router Between VXLAN Domains

With a VXLAN-stretched Layer 2 domain, a VM can point to an ASA as its gateway while the ASA is not on the same rack, or even when the ASA is far away over the Layer 3 network.

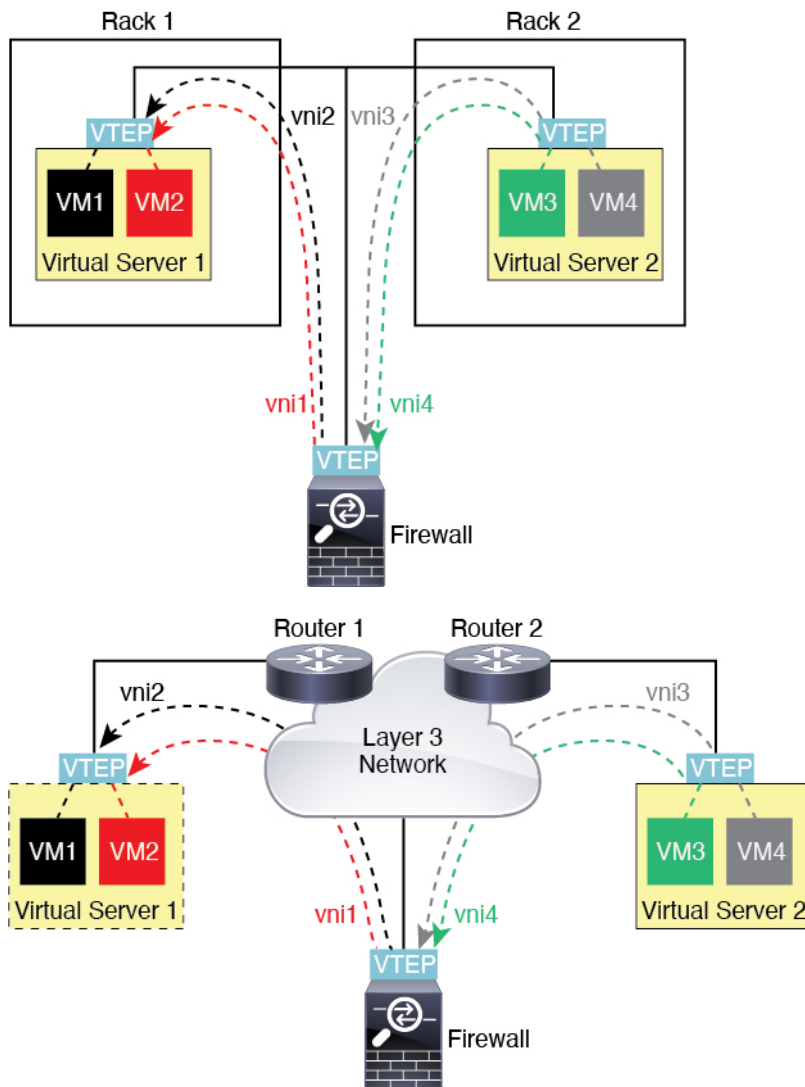

See the following notes about this scenario:

1. For packets from VM3 to VM1, the destination MAC address is the ASA MAC address, because the ASA is the default gateway.
2. The VTEP source interface on Virtual Server 2 receives packets from VM3, then encapsulates the packets with VNI 3's VXLAN tag and sends them to the ASA.
3. When the ASA receives the packets, it decapsulates the packets to get the inner frames.
4. The ASA uses the inner frames for route lookup, then finds that the destination is on VNI 2. If it does not already have a mapping for VM1, the ASA sends an encapsulated ARP broadcast on the multicast group IP on VNI 2.



Note The ASA must use dynamic VTEP peer discovery because it has multiple VTEP peers in this scenario.

5. The ASA encapsulates the packets again with the VXLAN tag for VNI 2 and sends the packets to Virtual Server 1. Before encapsulation, the ASA changes the inner frame destination MAC address to be the MAC of VM1 (multicast-encapsulated ARP might be needed for the ASA to learn the VM1 MAC address).
6. When Virtual Server 1 receives the VXLAN packets, it decapsulates the packets and delivers the inner frames to VM1.

AWS Gateway Load Balancer and Geneve Single-Arm Proxy



Note This use case is the only currently supported use case for Geneve interfaces.

The AWS Gateway Load Balancer combines a transparent network gateway and a load balancer that distributes traffic and scales virtual appliances on demand. The ASA virtual supports the Gateway Load Balancer centralized control plane with a distributed data plane (Gateway Load Balancer endpoint). The following figure shows traffic forwarded to the Gateway Load Balancer from the Gateway Load Balancer endpoint. The Gateway Load Balancer balances traffic among multiple ASA virtuals, which inspect the traffic before either dropping it or sending it back to the Gateway Load Balancer (U-turn traffic). The Gateway Load Balancer then sends the traffic back to the Gateway Load Balancer endpoint and to the destination.

Figure 1: Geneve Single-Arm Proxy

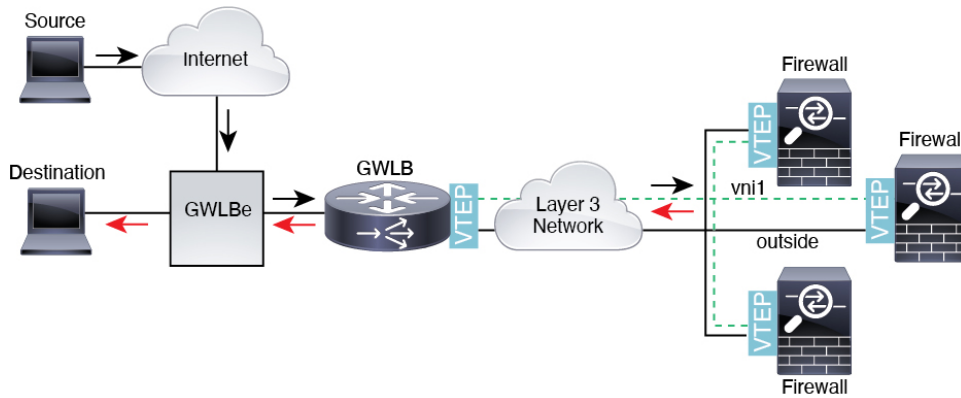

AWS Gateway Load Balancer and Geneve Dual-Arm Proxy



Note This use case is the only currently supported use case for Geneve interfaces.

The ASA virtual supports the Gateway Load Balancer centralized control plane with a distributed data plane (Gateway Load Balancer endpoint) with single-arm and dual-arm mode. The following figure shows outbound traffic (traffic inspected by ASA virtual) directly forwarded to the destination (Internet) without the need for traffic hop to the GWLB and GWLB endpoint. The ASA virtual inspect the outbound and perform NAT of the traffic before either dropping it or sending it back to the internet via NAT gateway. Dual-arm proxy provides a common egress path for multi-VPC deployment. The firewall inspects the outbound traffic from multiple VPCs, and it exits from a single point to the Internet, making it a cost-effective infrastructure solution.

Figure 2: Geneve Dual-Arm Proxy - Egress Traffic from single-VPC

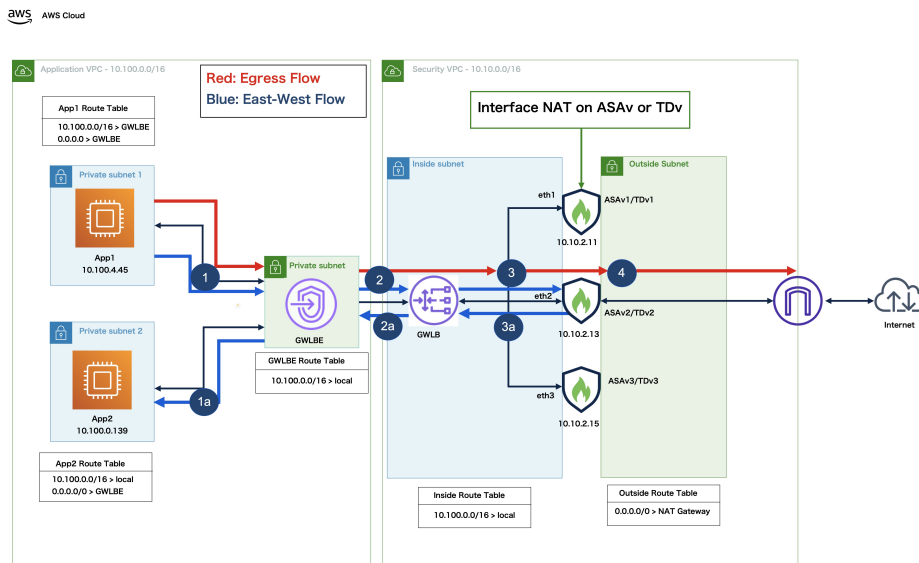
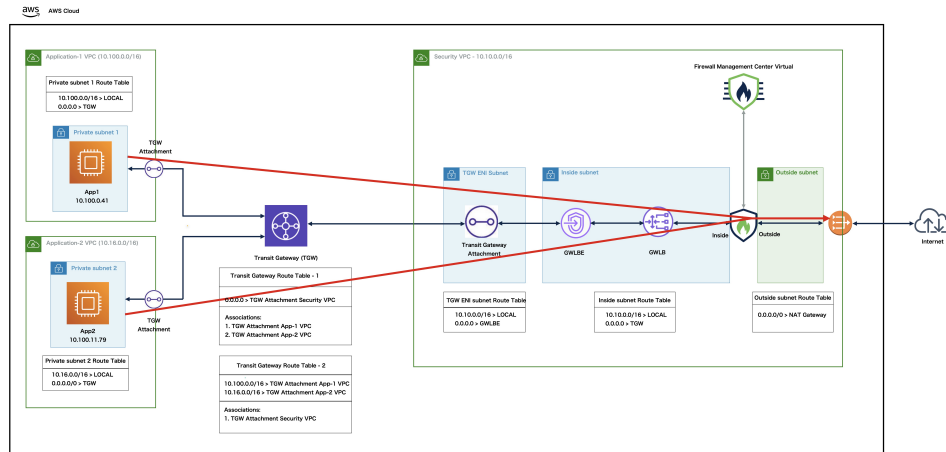

Figure 3: Geneve Dual-Arm Proxy - Egress Traffic from Multiple-VPC



Azure Gateway Load Balancer and Paired Proxy

In an Azure service chain, ASA virtuals act as a transparent gateway that can intercept packets between the internet and the customer service. The ASA virtual defines an external interface and an internal interface on a single NIC by utilizing VXLAN segments in a paired proxy.

The following figure shows traffic forwarded to the Azure Gateway Load Balancer from the Public Gateway Load Balancer on the external VXLAN segment. The Gateway Load Balancer balances traffic among multiple ASA virtuals, which inspect the traffic before either dropping it or sending it back to the Gateway Load Balancer on the internal VXLAN segment. The Azure Gateway Load Balancer then sends the traffic back to the Public Gateway Load Balancer and to the destination.

Figure 4: Azure Gateway Load Balancer with Paired Proxy

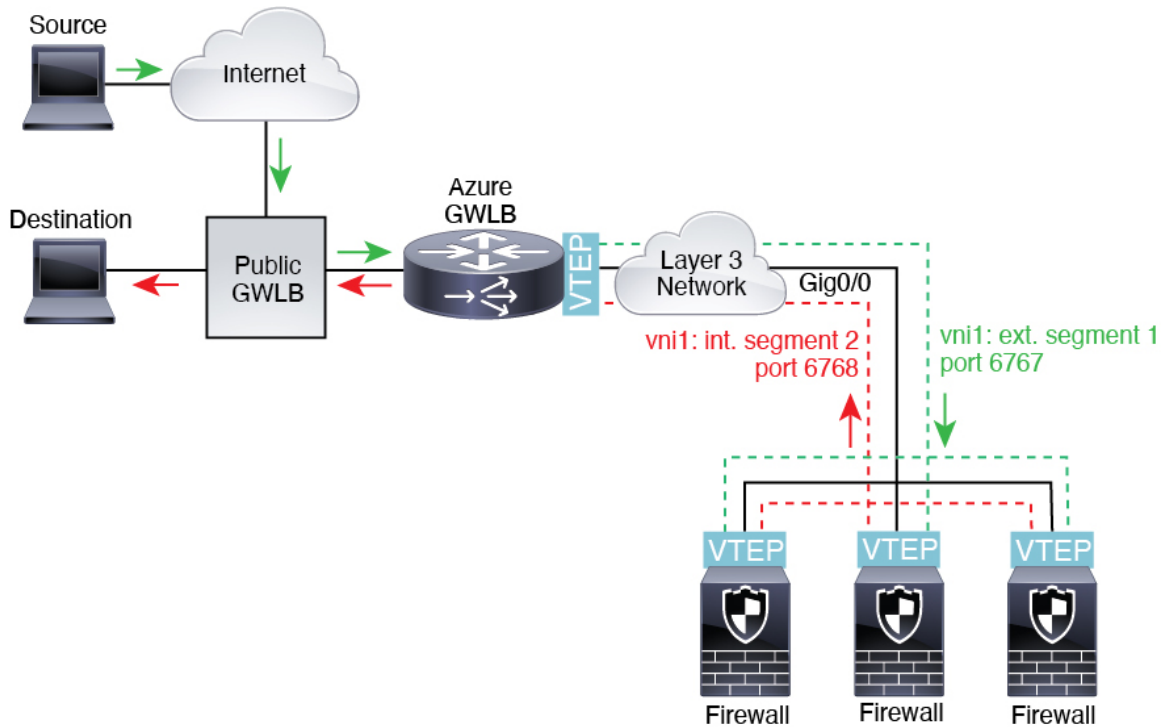

Requirements and Prerequisites for VXLAN Interfaces

Model Requirements

- Firepower 1010 and Secure Firewall 1210/1220 switch ports and VLAN interfaces are not supported as VTEP interfaces.
- Geneve encapsulation is supported for the following models: ASAv30, ASAv50, ASAv100 on Amazon Web Services (AWS)
- VXLAN in paired proxy mode is supported for the following models:
 - ASA virtual in Azure

Guidelines for VXLAN Interfaces

Firewall Mode

- Geneve interfaces are only supported in routed firewall mode.
- Paired proxy VXLAN interfaces are only supported in routed firewall mode.

IPv6

- The VNI interface supports both IPv4 and IPv6 traffic.
- For VXLAN encapsulation, the VTEP source interface supports both IPv4 and IPv6. The ASA virtual cluster control link VTEP source interface only supports IPv4.

For Geneve, the VTEP source interfaces only supports IPv4.

Clustering and Multiple Context Mode

- ASA clustering does not support VXLAN in Individual Interface mode except for the cluster control link (ASA virtual only). Only Spanned EtherChannel mode supports VXLAN.

An exception is made for the ASA virtual on AWS, which can use an additional Geneve interface for use with the GWLB and for Azure, which can use an additional paired proxy VXLAN interface for use with the GWLB.

- Geneve interfaces are only supported in single context mode. They are not supported with multiple context mode.

Routing

- Only static routing or Policy Based Routing is supported on the VNI interface; dynamic routing protocols are not supported.

MTU

- VXLAN encapsulation—If the source interface MTU is less than 1554 bytes for IPv4 or 1574 bytes for IPv6, then the ASA automatically raises the MTU. In this case, the entire Ethernet datagram is being encapsulated, so the new packet is larger and requires a larger MTU. If the MTU used by other devices is larger, then you should set the source interface MTU to be the network MTU + 54 bytes for IPv4 or +64 bytes for IPv6. This MTU requires you to enable jumbo frame reservation on some models; see [Enable Jumbo Frame Support \(ASA Virtual, ISA 3000\)](#).
- Geneve encapsulation—If the source interface MTU is less than 1806 bytes, then the ASA automatically raises the MTU to 1806 bytes. In this case, the entire Ethernet datagram is being encapsulated, so the new packet is larger and requires a larger MTU. If the MTU used by other devices is larger, then you should set the source interface MTU to be the network MTU + 306 bytes. This MTU requires you to enable jumbo frame reservation on some models; see [Enable Jumbo Frame Support \(ASA Virtual, ISA 3000\)](#).

Default Settings for VXLAN Interfaces

VNI interfaces are enabled by default.

Configure VXLAN Interfaces

To configure VXLAN, perform the following steps.



Note You can configure either VXLAN or Geneve (ASA virtual only). For Geneve interfaces, see [Configure Geneve Interfaces, on page 17](#).

Procedure

- Step 1** [Configure the VTEP Source Interface, on page 12](#).
 - Step 2** [Configure the VNI Interface, on page 14](#)
 - Step 3** (Optional) [Change the VXLAN UDP Port, on page 17](#).
 - Step 4** (Azure GWLB) [Allow Gateway Load Balancer Health Checks, on page 20](#).
-

Configure the VTEP Source Interface

You can configure one VTEP source interface per ASA or per security context. The VTEP is defined as a Network Virtualization Endpoint (NVE). An exception is made for clustering on the ASA virtual in Azure, where you can use one VTEP source interface for the cluster control link and a second one for the data interface connected to the Azure GWLB.

Before you begin

For multiple context mode, complete the tasks in this section in the context execution space. Enter the **changeto context name** command to change to the context you want to configure.

Procedure

- Step 1** (Transparent mode) Specify that the source interface is NVE-only:

interface *id*

nve-only

Example:

```
ciscoasa(config)# interface gigabitethernet 1/1
ciscoasa(config-if)# nve-only
```

This setting lets you configure an IP address for the interface. This command is optional for routed mode where this setting restricts traffic to VXLAN and common management traffic only on this interface.

- Step 2** Configure the source interface name and IPv4 and/or IPv6 address.

The ASA virtual cluster control link does not support IPv6.

Example:

(Routed Mode)

```
ciscoasa(config)# interface gigabitethernet 1/1
```

```
ciscoasa(config-if)# nameif outside
ciscoasa(config-if)# ip address 10.1.1.1 255.255.255.0
ciscoasa(config-if)# ipv6 address 2001:0DB8:BA98::3210/64
```

Example:

(Transparent Mode)

```
ciscoasa(config)# interface gigabitethernet 1/1
ciscoasa(config-if)# nve-only
ciscoasa(config-if)# nameif outside
ciscoasa(config-if)# ip address 10.1.1.1 255.255.255.0
ciscoasa(config-if)# ipv6 address 2001:0DB8:BA98::3210/64
```

Step 3 Specify the NVE instance:

nve 1

You can only specify one NVE instance, with the ID 1.

Example:

```
ciscoasa(config)# nve 1
ciscoasa(cfg-nve)#
```

Step 4 Specify VXLAN encapsulation.

encapsulation vxlan**Example:**

```
ciscoasa(cfg-nve)# encapsulation vxlan
```

Step 5 Specify the source interface name that you configured in [Step 2](#):

source-interface interface-name**Example:**

```
ciscoasa(cfg-nve)# source-interface outside
```

Note If the VTEP interface MTU is less than 1554 bytes for IPv4 or 1574 bytes for IPv6, then the ASA automatically raises the MTU to 1554 bytes or 1574 bytes.

Step 6 (Multiple context mode; Optional for single mode) Manually specify the peer VTEP IP address:

peer ip ip_address**Example:**

IPv4 peer

```
ciscoasa(cfg-nve)# peer ip 10.1.1.2
```

Example:

IPv6 peer:

```
ciscoasa(cfg-nve)# peer ip 2001:0DB8:BA98::1234
```

If you specify the peer IP address, you cannot use multicast group discovery. Multicast is not supported in multiple context mode, so manual configuration is the only option. You can only specify one peer for the VTEP.

Step 7 (Optional; single mode only) Specify a default multicast group for all associated VNI interfaces:

default-mcast-group *mcast_ip*

Example:

IPv4 group

```
ciscoasa(cfg-nve)# default-mcast-group 236.0.0.100
```

Example:

IPv6 group

```
ciscoasa(cfg-nve)# default-mcast-group ff0e::100
```

If you do not configure the multicast group per VNI interface, then this group is used. If you configure a group at the VNI interface level, then that group overrides this setting.

Configure the VNI Interface

Add a VNI interface, associate it with the VTEP source interface, and configure basic interface parameters.

For the ASA virtual in Azure, you can configure either a regular VXLAN interface, or you can configure a paired proxy mode VXLAN interface for use with the Azure GWLB. Paired proxy mode is the only supported mode with clustering.

Procedure

Step 1 Create the VNI interface:

interface vni *vni_num*

Example:

```
ciscoasa(config)# interface vni 1
```

Set the ID between 1 and 10000. This ID is only an internal interface identifier.

Step 2 (Regular VXLAN) Specify the VXLAN segment ID:

segment-id *id*

Example:

```
ciscoasa(config-if)# segment-id 1000
```

Set the ID between 1 and 16777215. The segment ID is used for VXLAN tagging.

Step 3 (Paired Proxy VXLAN for Azure GWLB) Enable proxy paired mode and set the required parameters.

a) Enable proxy paired mode.

proxy paired

Example:

```
ciscoasa(config-if)# proxy paired
```

b) Set the internal port.

internal-port *port_number*

Where the *port_number* is between 1024 and 65535.

Example:

```
ciscoasa(config-if)# internal-port 2000
```

c) Set the internal segment ID.

internal-segment-id *id_number*

Where the *id_number* is between 1 and 16777215.

Example:

```
ciscoasa(config-if)# internal-segment-id 101
```

d) Set the external port.

external-port *port_number*

Where the *port_number* is between 1024 and 65535.

Example:

```
ciscoasa(config-if)# external-port 2001
```

e) Set the external segment ID.

external-segment-id *id_number*

Where the *id_number* is between 1 and 16777215.

Example:

```
ciscoasa(config-if)# external-segment-id 102
```

f) Allow traffic to enter and exit the same interface.

same-security-traffic permit intra-interface

Example:

```
ciscoasa(config)# same-security-traffic permit intra-interface
```

Step 4 (Required for transparent mode) Specify the bridge group to which you want to associate this interface:

bridge-group *number*

Example:

```
ciscoasa(config-if)# bridge-group 1
```

See [Configure Bridge Group Interfaces](#) to configure the BVI interface and associate regular interfaces to this bridge group.

Step 5 Associate this interface with the VTEP source interface:

vtep-nve *1*

Step 6 Name the interface:

nameif *vni_interface_name*

Example:

```
ciscoasa(config-if)# nameif vxlan1000
```

The *name* is a text string up to 48 characters, and is not case-sensitive. You can change the name by reentering this command with a new value. Do not enter the **no** form, because that command causes all commands that refer to that name to be deleted.

Step 7 (Routed mode) Assign an IPv4 and/or IPv6 address:

ip address {*ip_address* [*mask*] [**standby** *ip_address*] | **dhcp** [**setroute**] | **pppoe** [**setroute**]}

ipv6 address {**autoconfig** | *ipv6-address/prefix-length* [**standby** *ipv6-address*]}

Example:

```
ciscoasa(config-if)# ip address 192.168.1.1 255.255.255.0 standby 192.168.1.2
ciscoasa(config-if)# ipv6 address 2001:0DB8::BA98:0:3210/48
```

Step 8 Set the security level:

security-level *level*

Example:

```
ciscoasa(config-if)# security-level 50
```

Where *number* is an integer between 0 (lowest) and 100 (highest).

Step 9 (Single mode) Set the multicast group address:

mcast-group *multicast_ip*

Example:

IPv4 group:

```
ciscoasa(config-if)# mcast-group 236.0.0.100
```

Example:

IPv6 group:

```
ciscoasa(config-if)# mcast-group ff0e::101
```

If you do not set the multicast group for the VNI interface, the default group from the VTEP source interface configuration is used, if available. If you manually set a VTEP peer IP for the VTEP source interface, you cannot specify a multicast group for the VNI interface. Multicast is not supported in multiple context mode.

(Optional) Change the VXLAN UDP Port

By default, the VTEP source interface accepts VXLAN traffic to UDP port 4789. If your network uses a non-standard port, you can change it.

Before you begin

For multiple context mode, complete this task in the system execution space. To change from the context to the system execution space, enter the **changeto system** command.

Procedure

Set the VXLAN UDP port:

vxlan *port number*

Example:

```
ciscoasa(config)# vxlan port 5678
```

Configure Geneve Interfaces

To configure Geneve interfaces for the ASA virtual, perform the following steps.



Note

You can configure either VXLAN or Geneve. For VXLAN interfaces, see [Configure VXLAN Interfaces, on page 11](#).

Procedure

- Step 1** [Configure the VTEP Source Interface for Geneve, on page 18.](#)
 - Step 2** [Configure the VNI Interface for Geneve, on page 19](#)
 - Step 3** [Allow Gateway Load Balancer Health Checks, on page 20.](#)
-

Configure the VTEP Source Interface for Geneve

You can configure one VTEP source interface per ASA virtual. The VTEP is defined as a Network Virtualization Endpoint (NVE).

Procedure

- Step 1** (Optional) Specify that the source interface is NVE-only.

interface *id*

nve-only

Example:

```
ciscoasa(config)# interface gigabitethernet 1/1
ciscoasa(config-if)# nve-only
```

This setting restricts traffic to VXLAN and common management traffic only on this interface.

- Step 2** Configure the source interface name and IPv4 address.

Example:

```
ciscoasa(config)# interface gigabitethernet 1/1
ciscoasa(config-if)# nameif outside
ciscoasa(config-if)# ip address 10.1.1.1 255.255.255.0
```

- Step 3** Specify the NVE instance:

nve 1

You can only specify one NVE instance, with the ID 1.

Example:

```
ciscoasa(config)# nve 1
ciscoasa(cfg-nve)#
```

- Step 4** Specify Geneve encapsulation.

encapsulation geneve

Do not change the Geneve port; AWS requires a port of 6081.

Example:

```
ciscoasa(cfg-nve)# encapsulation geneve
```

Step 5 Specify the source interface name that you configured in [Step 2](#):

source-interface *interface-name*

Example:

```
ciscoasa(cfg-nve)# source-interface outside
```

Note If the source interface MTU is less than 1806 bytes, then the ASA automatically raises the MTU to 1806 bytes.

Configure the VNI Interface for Geneve

Add a VNI interface, associate it with the VTEP source interface, and configure basic interface parameters.

Procedure

Step 1 Create the VNI interface:

interface vni *vni_num*

Example:

```
ciscoasa(config)# interface vni 1
```

Set the ID between 1 and 10000. This ID is only an internal interface identifier.

Step 2 Associate this interface with the VTEP source interface:

vtep-nve 1

Step 3 Name the interface:

nameif *vni_interface_name*

Example:

```
ciscoasa(config-if)# nameif geneve1000
```

The *name* is a text string up to 48 characters, and is not case-sensitive. You can change the name by reentering this command with a new value. Do not enter the **no** form, because that command causes all commands that refer to that name to be deleted.

Step 4 Assign an IPv4 and/or IPv6 address:

ip address {*ip_address* [*mask*] [**standby** *ip_address*]}

ipv6 address {**autoconfig** | *ipv6-address/prefix-length* [**standby** *ipv6-address*]}

Geneve only supports a static IP address.

Example:

```
ciscoasa(config-if)# ip address 192.168.1.1 255.255.255.0 standby 192.168.1.2
ciscoasa(config-if)# ipv6 address 2001:0DB8::BA98:0:3210/48
```

Step 5 Set the security level:

security-level *level*

Where *level* is an integer between 0 (lowest) and 100 (highest).

Example:

```
ciscoasa(config-if)# security-level 50
```

Step 6 Enable single-arm proxy or dual-arm proxy.

proxy single-arm

Example:

```
ciscoasa(config-if)# proxy single-arm
```

proxy dual-arm

Example:

```
ciscoasa(config-if)# proxy single-arm | dual-arm
```

Where,

proxy is the keyword to specify which mode VNI interface will be running.

single-arm or **dual-arm** is the keyword to specify AWS single-arm or dual-arm deployment mode.

Step 7 Allow traffic to enter and exit the same interface.

same-security-traffic permit intra-interface

Example:

```
ciscoasa(config)# same-security-traffic permit intra-interface
```

Allow Gateway Load Balancer Health Checks

The AWS or Azure Gateway Load Balancer requires appliances to answer a health check properly. The AWS Gateway Load Balancer will only send traffic to appliances that are considered healthy.

You must configure the ASA virtual to respond to an SSH, Telnet, HTTP, or HTTPS health check.

SSH Connection

For SSH, allow SSH from the Gateway Load Balancer. The Gateway Load Balancer will attempt to establish a connection to the ASA virtual, and the ASA virtual's prompt to log in is taken as proof of health.



Note An SSH login attempt will time out after 1 minute. You will need to configure a longer health check interval on the Gateway Load Balancer to accommodate this timeout.

Example

```
! Allow SSH connections from GWLB network: 10.0.1.0/24
ssh 10.0.1.0 255.255.255.0 outside
```

Telnet Connection

For Telnet, allow Telnet from the Gateway Load Balancer. The Gateway Load Balancer will attempt to establish a connection to the ASA virtual, and the ASA virtual's prompt to log in is taken as proof of health.



Note You cannot Telnet to the lowest security level interface, so this method may not be practical.

Example

```
! Allow Telnet connections from GWLB network: 10.0.1.0/24
telnet 10.0.1.0 255.255.255.0 outside
```

HTTP(S) Cut-Through Proxy

You can configure the ASA to prompt the Gateway Load Balancer for an HTTP(S) login.

Example

```
! Identify health probe HTTP traffic from GWLB nw 10.0.1.0/24 to ASAv interface 10.2.2.2
access-list gwlb extended permit tcp 10.0.1.0 255.255.255.0 host 10.2.2.2 eq www
! Enable HTTP authentication
aaa authentication http console LOCAL
! Require authentication for the health probe traffic
aaa authentication match gwlb outside LOCAL
! Use an HTTP login page on the ASA
aaa authentication listener http outside port www
```

HTTP(S) Redirection Using Static Interface NAT with Port Translation

You can configure the ASA virtual to redirect health checks to a metadata HTTP(S) server. For HTTP(S) health checks, the HTTP(S) server must reply to the Gateway Load Balancer with a status code in the range 200 to 399. Because the ASA virtual has limits on the the number of simultaneous management connections, you may choose to offload the health check to an external server.

Static interface NAT with port translation lets you redirect a connection to a port (such as port 80) to a different IP address. For example, translate an HTTP packet from the Gateway Load Balancer with a destination of the

ASA virtual outside interface so that it appears to be from the ASA virtual outside interface with a destination of the HTTP server. The ASA virtual then forwards the packet to the mapped destination address. The HTTP server responds to the ASA virtual outside interface, and then the ASA virtual forwards the response back to the Gateway Load Balancer. You need an access rule that allows traffic from the Gateway Load Balancer to the HTTP server.

Example

```
! Permit HTTP traffic from GWLB nw 10.0.1.0/24 to HTTP server 10.2.2.3
access-list gwlb-health extended permit tcp 10.0.1.0 255.255.255.0 host 10.2.2.3 eq www
access-group gwlb-health in interface outside

! Create network objects
object network gwlb-subnet
 subnet 10.0.1.0 255.255.255.0
object-group network gwlb
 network-object object gwlb-subnet
object-group network http-server
 network-object host 10.2.2.3
object service http80
 service tcp destination eq www

! For HTTP, translate src GWLB IP to outside IP; translate dest of outside IP to HTTP Server
IP
nat (outside,outside) source static gwlb interface destination static interface http-server
 service http80 http80
```

Monitoring VXLAN Interfaces

See the following commands to monitor VTEP and VNI interfaces.

- **show nve** [*id*] [**summary**]

This command shows the parameters, status and statistics of a NVE interface, status of its carrier interface (source-interface), IP address of the carrier interface, VNIs that use this NVE as the VXLAN VTEP, and peer VTEP IP addresses associated with this NVE interface. With the **summary** option, this command only shows the status of the NVE interface, number of VNIs behind the NVE interface, and number of VTEPs discovered.

See the following output for the **show nve 1** command:

```
ciscoasa# show nve 1
ciscoasa(config-if)# show nve
nve 1, source-interface "inside" is up
IP address 15.1.2.1, subnet mask 255.255.255.0
Encapsulation: vxlan
Encapsulated traffic statistics:
6701004 packets input, 3196266002 bytes
6700897 packets output, 3437418084 bytes
1 packets dropped
Number of configured static peer VTEPs: 0
Number of discovered peer VTEPs: 1
Discovered peer VTEPs:
IP address 15.1.2.3
Number of VNIs attached to nve 1: 2
VNIs attached:
vni 2: segment-id 5002, mcast-group 239.1.2.3
```

```
vni 1: segment-id 5001, mcast-group 239.1.2.3
```

See the following output for the **show nve 1 summary** command:

```
ciscoasa# show nve 1 summary
nve 1, source-interface "inside" is up
Encapsulation: vxlan
Number of configured static peer VTEPs: 0
Number of discovered peer VTEPs: 1
Default multicast group: 239.1.2.3
Number of VNIs attached to nve 1: 2
```

- **show interface vni id [summary]**

This command shows the parameters, status and statistics of a VNI interface, status of its bridged interface (if configured), and NVE interface it is associated with. The **summary** option shows only the VNI interface parameters.

See the following output for the **show interface vni 1** command:

```
ciscoasa# show interface vni 1
Interface vni1 "vni-inside", is up, line protocol is up
VTEP-NVE 1
Segment-id 5001
Tag-switching: disabled
MTU: 1500
MAC: aaaa.bbbb.1234
IP address 192.168.0.1, subnet mask 255.255.255.0
Multicast group 239.1.3.3
Traffic Statistics for "vni-inside":
235 packets input, 23606 bytes
524 packets output, 32364 bytes
14 packets dropped
1 minute input rate 0 pkts/sec, 0 bytes/sec
1 minute output rate 0 pkts/sec, 2 bytes/sec
1 minute drop rate, 0 pkts/sec
5 minute input rate 0 pkts/sec, 0 bytes/sec
5 minute output rate 0 pkts/sec, 0 bytes/sec
5 minute drop rate, 0 pkts/sec
```

See the following output for the **show interface vni 1 summary** command:

```
ciscoasa# show interface vni 1 summary
Interface vni1 "vni-inside", is up, line protocol is up
VTEP-NVE 1
Segment-id 5001
Tag-switching: disabled
MTU: 1500
MAC: aaaa.bbbb.1234
IP address 192.168.0.1, subnet mask 255.255.255.0
Multicast group not configured
```

- **show vni vlan-mapping**

This command shows the mapping between VNI segment IDs and VLAN interfaces or physical interfaces. This command is only valid in transparent firewall mode because in routed mode, the mapping between VXLANs and VLANs can include too many values to show.

See the following output for the **show vni vlan-mapping** command:

```
ciscoasa# show vni vlan-mapping
vni1: segment-id: 6000, interface: 'g0110', vlan 10, interface: 'g0111', vlan 11
vni2: segment_id: 5000, interface: 'g01100', vlan 1, interface: 'g111', vlan 3, interface:
'g112', vlan 4
```

- **show arp vtep-mapping**

This command displays MAC addresses cached on the VNI interface for IP addresses located in the remote segment domain and the remote VTEP IP addresses.

See the following output for the **show arp vtep-mapping** command:

```
ciscoasa# show arp vtep-mapping
vni-outside 192.168.1.4 0012.0100.0003 577 15.1.2.3
vni-inside 192.168.0.4 0014.0100.0003 577 15.1.2.3
```

- **show mac-address-table vtep-mapping**

This command displays the Layer 2 forwarding table (MAC address table) on the VNI interface with the remote VTEP IP addresses.

See the following output for the **show mac-address-table vtep-mapping** command:

```
ciscoasa# show mac-address-table vtep-mapping
interface                mac address      type      Age(min)  bridge-group  VTEP
-----
vni-outside              00ff.9200.0000  dynamic   5         1             10.9.1.3
vni-inside                0041.9f00.0000  dynamic   5         1             10.9.1.3
```

Examples for VXLAN Interfaces

See the following configuration examples for VXLAN.

Transparent VXLAN Gateway Example

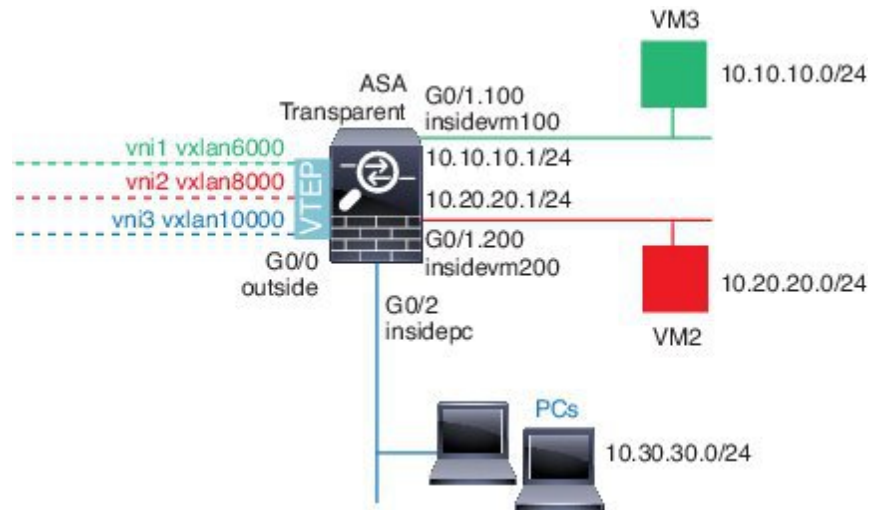

See the following description of this example:

- The outside interface on GigabitEthernet 0/0 is used as the VTEP source interface, and it is connected to the Layer 3 network.
- The insidevm100 VLAN subinterface on GigabitEthernet 0/1.100 is connected to the 10.10.10.0/24 network, on which VM3 resides. When VM3 communicates with VM1 (not shown; both have 10.10.10.0/24 IP addresses), the ASA uses VXLAN tag 6000.
- The insidevm200 VLAN subinterface on GigabitEthernet 0/1.200 is connected to the 10.20.20.0/24 network, on which VM2 resides. When VM2 communicates with VM4 (not shown; both have 10.20.20.0/24 IP addresses), the ASA uses VXLAN tag 8000.
- The insidepc interface on GigabitEthernet 0/2 is connected to the 10.30.30.0/24 network on which a few PCs reside. When those PCs communicate with VMs/PCs (not shown) behind a remote VTEP that belongs to same network (all have 10.30.30.0/24 IP addresses), the ASA uses VXLAN tag 10000.

ASA Configuration

```

firewall transparent
vxlan port 8427
!
interface gigabitethernet0/0
 nve-only
 nameif outside
 ip address 192.168.1.30 255.255.255.0
 no shutdown
!
nve 1
 encapsulation vxlan
 source-interface outside
!
interface vni1
 segment-id 6000
 nameif vxlan6000
 security-level 0
 bridge-group 1

```

```

vtep-nve 1
mcast-group 235.0.0.100
!
interface vni2
segment-id 8000
nameif vxlan8000
security-level 0
bridge-group 2
vtep-nve 1
mcast-group 236.0.0.100
!
interface vni3
segment-id 10000
nameif vxlan10000
security-level 0
bridge-group 3
vtep-nve 1
mcast-group 236.0.0.100
!
interface gigabitethernet0/1.100
nameif insidevm100
security-level 100
bridge-group 1
!
interface gigabitethernet0/1.200
nameif insidevm200
security-level 100
bridge-group 2
!
interface gigabitethernet0/2
nameif insidepc
security-level 100
bridge-group 3
!
interface bvi 1
ip address 10.10.10.1 255.255.255.0
!
interface bvi 2
ip address 10.20.20.1 255.255.255.0
!
interface bvi 3
ip address 10.30.30.1 255.255.255.0

```

Notes

- For VNI interfaces vni1 and vni2, the inner VLAN tag is removed during encapsulation.
- VNI interfaces vni2 and vni3 share the same multicast IP address for encapsulated ARP over multicast. This sharing is allowed.
- The ASA bridges the VXLAN traffic to non-VXLAN-supported interfaces based on the above BVIs and bridge group configurations. For each of the stretched Layer 2 network segments (10.10.10.0/24, 10.20.20.0/24 and 10.30.30.0/24), the ASA serves as a bridge.
- It is allowed to have more than one VNI or more than one regular interface (VLAN or just physical interface) in a bridge group. The forwarding or association between VXLAN segment ID to the VLAN ID (or a physical interface) is decided by the destination MAC address and which interface connects to the destination.

- The VTEP source-interface is a Layer 3 interface in transparent firewall mode indicated by **nve-only** in the interface configuration. The VTEP source interface is not a BVI interface or a management interface, but it has an IP address and uses the routing table.

VXLAN Routing Example

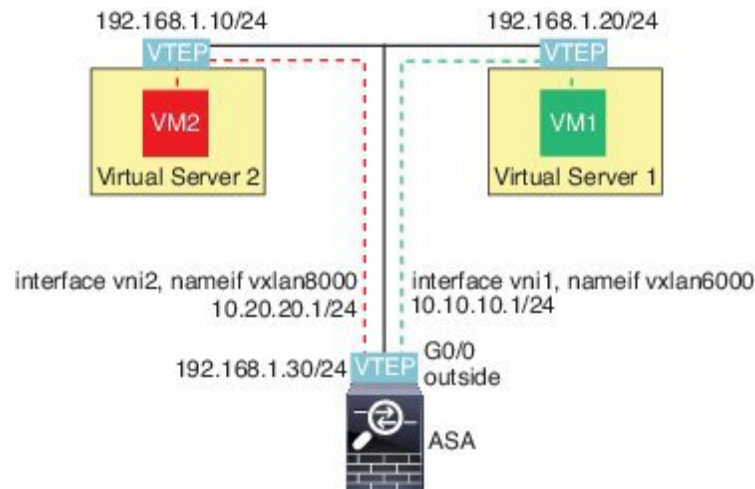

See the following description of this example:

- VM1 (10.10.10.10) is hosted on Virtual Server 1, and VM2 (10.20.20.20) is hosted on Virtual Server 2.
- The default gateway for VM1 is the ASA, which is not in the same pod as Virtual Server 1, but VM1 is not aware of it. VM1 only knows that its default gateway IP address is 10.10.10.1. Similarly, VM2 only knows that its default gateway IP address is 10.20.20.1.
- The VTEP-supported hypervisors on Virtual Server 1 and 2 are able to communicate with the ASA over the same subnet or through a Layer 3 network (not shown; in which case, the ASA and uplinks of virtual servers have different network addresses).
- VM1's packet will be encapsulated by its hypervisor's VTEP and sent to its default gateway over VXLAN tunneling.
- When VM1 sends a packet to VM2, the packet will be sent through default gateway 10.10.10.1 from its perspective. Virtual Server1 knows 10.10.10.1 is not local, so the VTEP encapsulates the packet over VXLAN and sends it to ASA's VTEP.
- On the ASA, the packet is decapsulated. The VXLAN segment ID is learned during decapsulation. The ASA then re-injects the inner frame to the corresponding VNI interface (vni1) based on the VXLAN segment ID. The ASA then conducts a route lookup and sends the inner packet through another VNI interface, vni2. All egressing packets through vni2 are encapsulated with VXLAN segment 8000 and sent through the VTEP to outside.
- Eventually the encapsulated packet is received by the VTEP of Virtual Server 2, which decapsulates it and forwards it to VM2.

ASA Configuration

```

interface gigabitethernet0/0
  nameif outside
  ip address 192.168.1.30 255.255.255.0
  no shutdown
!
nve 1
  encapsulation vxlan
  source-interface outside
  default-mcast-group 235.0.0.100
!
interface vni1
  segment-id 6000
  nameif vxlan6000
  security-level 0
  vtep-nve 1
  ip address 10.20.20.1 255.255.255.0
!
interface vni2
  segment-id 8000
  nameif vxlan8000
  security-level 0
  vtep-nve 1
  ip address 10.10.10.1 255.255.255.0
!

```

History for VXLAN Interfaces

Table 1: History for VXLAN Interfaces

Feature Name	Release	Feature Information
VXLAN VTEP IPv6 support	9.20(1)	You can now specify an IPv6 address for the VXLAN VTEP interface. IPv6 is not supported for the ASA virtual cluster control link or for Geneve encapsulation. New/Modified commands: default-mcast-group , mcast-group , peer ip
Paired proxy VXLAN for the ASA virtual for the Azure Gateway Load Balancer	9.19(1)	You can configure a paired proxy mode VXLAN interface for the ASA virtual in Azure for use with the Azure Gateway Load Balancer (GWLb). The ASA virtual defines an external interface and an internal interface on a single NIC by utilizing VXLAN segments in a paired proxy. New/Modified commands: external-port , external-segment-id , internal-port , internal-segment-id , proxy paired
Geneve support for the ASA virtual on AWS for the AWS Gateway Load Balancer	9.17(1)	Geneve encapsulation support was added for the ASA v30, ASA v50, and ASA v100 to support single-arm proxy for the AWS Gateway Load Balancer. New/Modified commands: debug geneve , debug nve , debug vxlan , encapsulation , packet-tracer geneve , proxy single-arm , show asp drop , show capture , show interface , show nve ,

Feature Name	Release	Feature Information
VXLAN support	9.4(1)	<p>VXLAN support was added, including VXLAN tunnel endpoint (VTEP) support. You can define one VTEP source interface per ASA or security context.</p> <p>We introduced the following commands: debug vxlan, default-mcast-group, encapsulation vxlan, inspect vxlan, interface vni, mcast-group, nve, nve-only, peer ip, segment-id, show arp vtep-mapping, show interface vni, show mac-address-table vtep-mapping, show nve, show vni vlan-mapping, source-interface, vtep-nve, vxlan port</p>

