



## **Cisco Catalyst IR8340 Rugged Series Router Hardware Installation Guide**

**First Published:** 2022-05-26

**Last Modified:** 2022-07-28

### **Americas Headquarters**

Cisco Systems, Inc.  
170 West Tasman Drive  
San Jose, CA 95134-1706  
USA  
<http://www.cisco.com>  
Tel: 408 526-4000  
800 553-NETS (6387)  
Fax: 408 527-0883

THE SPECIFICATIONS AND INFORMATION REGARDING THE PRODUCTS IN THIS MANUAL ARE SUBJECT TO CHANGE WITHOUT NOTICE. ALL STATEMENTS, INFORMATION, AND RECOMMENDATIONS IN THIS MANUAL ARE BELIEVED TO BE ACCURATE BUT ARE PRESENTED WITHOUT WARRANTY OF ANY KIND, EXPRESS OR IMPLIED. USERS MUST TAKE FULL RESPONSIBILITY FOR THEIR APPLICATION OF ANY PRODUCTS.

THE SOFTWARE LICENSE AND LIMITED WARRANTY FOR THE ACCOMPANYING PRODUCT ARE SET FORTH IN THE INFORMATION PACKET THAT SHIPPED WITH THE PRODUCT AND ARE INCORPORATED HEREIN BY THIS REFERENCE. IF YOU ARE UNABLE TO LOCATE THE SOFTWARE LICENSE OR LIMITED WARRANTY, CONTACT YOUR CISCO REPRESENTATIVE FOR A COPY.

The following information is for FCC compliance of Class A devices: This equipment has been tested and found to comply with the limits for a Class A digital device, pursuant to part 15 of the FCC rules. These limits are designed to provide reasonable protection against harmful interference when the equipment is operated in a commercial environment. This equipment generates, uses, and can radiate radio-frequency energy and, if not installed and used in accordance with the instruction manual, may cause harmful interference to radio communications. Operation of this equipment in a residential area is likely to cause harmful interference, in which case users will be required to correct the interference at their own expense.

The following information is for FCC compliance of Class B devices: This equipment has been tested and found to comply with the limits for a Class B digital device, pursuant to part 15 of the FCC rules. These limits are designed to provide reasonable protection against harmful interference in a residential installation. This equipment generates, uses and can radiate radio frequency energy and, if not installed and used in accordance with the instructions, may cause harmful interference to radio communications. However, there is no guarantee that interference will not occur in a particular installation. If the equipment causes interference to radio or television reception, which can be determined by turning the equipment off and on, users are encouraged to try to correct the interference by using one or more of the following measures:

- Reorient or relocate the receiving antenna.
- Increase the separation between the equipment and receiver.
- Connect the equipment into an outlet on a circuit different from that to which the receiver is connected.
- Consult the dealer or an experienced radio/TV technician for help.

Modifications to this product not authorized by Cisco could void the FCC approval and negate your authority to operate the product.

The Cisco implementation of TCP header compression is an adaptation of a program developed by the University of California, Berkeley (UCB) as part of UCB's public domain version of the UNIX operating system. All rights reserved. Copyright © 1981, Regents of the University of California.

NOTWITHSTANDING ANY OTHER WARRANTY HEREIN, ALL DOCUMENT FILES AND SOFTWARE OF THESE SUPPLIERS ARE PROVIDED "AS IS" WITH ALL FAULTS. CISCO AND THE ABOVE-NAMED SUPPLIERS DISCLAIM ALL WARRANTIES, EXPRESSED OR IMPLIED, INCLUDING, WITHOUT LIMITATION, THOSE OF MERCHANTABILITY, FITNESS FOR A PARTICULAR PURPOSE AND NON-INFRINGEMENT OR ARISING FROM A COURSE OF DEALING, USAGE, OR TRADE PRACTICE.

IN NO EVENT SHALL CISCO OR ITS SUPPLIERS BE LIABLE FOR ANY INDIRECT, SPECIAL, CONSEQUENTIAL, OR INCIDENTAL DAMAGES, INCLUDING, WITHOUT LIMITATION, LOST PROFITS OR LOSS OR DAMAGE TO DATA ARISING OUT OF THE USE OR INABILITY TO USE THIS MANUAL, EVEN IF CISCO OR ITS SUPPLIERS HAVE BEEN ADVISED OF THE POSSIBILITY OF SUCH DAMAGES.

Any Internet Protocol (IP) addresses and phone numbers used in this document are not intended to be actual addresses and phone numbers. Any examples, command display output, network topology diagrams, and other figures included in the document are shown for illustrative purposes only. Any use of actual IP addresses or phone numbers in illustrative content is unintentional and coincidental.

All printed copies and duplicate soft copies of this document are considered uncontrolled. See the current online version for the latest version.

Cisco has more than 200 offices worldwide. Addresses and phone numbers are listed on the Cisco website at [www.cisco.com/go/offices](http://www.cisco.com/go/offices).

Cisco and the Cisco logo are trademarks or registered trademarks of Cisco and/or its affiliates in the U.S. and other countries. To view a list of Cisco trademarks, go to this URL: <https://www.cisco.com/c/en/us/about/legal/trademarks.html>. Third-party trademarks mentioned are the property of their respective owners. The use of the word partner does not imply a partnership relationship between Cisco and any other company. (1721R)

© 2022 Cisco Systems, Inc. All rights reserved.



## CONTENTS

### [Introduction](#) ?

---

#### PREFACE

#### [Preface](#) vii

[Objective](#) vii

[Audience](#) vii

[Conventions](#) vii

[Safety Warnings](#) viii

[Related Documentation](#) xiii

[Communications, Services, and Additional Information](#) xiv

[Cisco Bug Search Tool](#) xiv

[Documentation Feedback](#) xiv

---

#### CHAPTER 1

#### [Product Overview](#) 1

[Chassis Views](#) 1

[Hardware Features](#) 1

[Alarm Ports](#) 2

[Alarm Input](#) 2

[Alarm Output](#) 3

[Console Port](#) 3

[Power-Input Terminal](#) 3

[100/1000 SFP Ports \(Uplinks\)](#) 3

[100/1000 SFP Ports \(Downlinks\)](#) 3

[10/100/1000 PoE/PoE+/UPoE Ports \(Downlinks\)](#) 4

[mSATA Module](#) 5

[Timing Module](#) 5

[SD Flash Memory Card](#) 6

Network Interface Modules	6	
Cisco Pluggable Modules	6	
Pluggable LTE Module	7	
LTE Category 18 Pluggable Module	8	
5G Pluggable Interface Module	9	
Supported Cisco Antennas and Antenna Accessories	10	
LEDs	10	
Cable Side View LEDs	11	
Power Supply Side View	13	
Power Supply Features	14	
<hr/>		
<b>CHAPTER 2</b>	<b>Preparing for Router Installation</b>	<b>15</b>
	Safety Recommendations	15
	Safety with Electricity	15
	Preventing Electrostatic Discharge Damage	16
	General Site Requirements	16
	Rack Requirements	17
	Router Environmental Requirements	17
	Power Guidelines and Requirements	17
	Network Cabling Specifications	18
	Console Port Connection	18
	Preparing for Network Connections	18
	Ethernet Connections	18
	Serial Connections	18
	Required Tools and Equipment for Installation and Maintenance	20
<hr/>		
<b>CHAPTER 3</b>	<b>Installing and Connecting the Router</b>	<b>23</b>
	Installing and Connecting the Router	23
	Safety Warnings	23
	Statement 191—Voluntary Control Council for Interference (VCCI) Class A Warning for Japan	25
	ステートメント 191—日本向け VCCI クラス A に関する警告	26
	Statement 1008—Class 1 Laser Product	26
	ステートメント 1008—クラス 1 レーザー製品	26
	Before You Begin	26

Unpacking the Router	26
Installing the Router in a Rack	27
Rack-Mounting the Chassis	27
Attaching Rack-Mount Brackets to Cisco IR8340 Routers	27
Mounting the Router in a Rack	29
Replacing the SD Flash Memory Card	29
Connecting the Console Port	30
Console Port Connection to a PC	30
Console Port Signaling and Cabling with a DB-9 Adapter	30
Console Port Signaling and Cabling with a DB-25 Adapter	31
Connecting WAN and LAN Interfaces	31
Connection Procedures and Precautions	32

---

**CHAPTER 4**
**Power Supply Installation 33**

Power Supply Installation	33
Power-Supply Modules	33
Power-Supply Module LEDs	34
Power-Supply Module Installation	35
Installation Guidelines	35
Installing a Power-Supply Module	35
Equipment That You Need	36
Grounding the router	36
Installing the Power Supply Module in the Router	38
Installing the DC Power Supply in the Router	39
Wiring the Power Source	39
Removing the Power Supply Module	44

---

**CHAPTER 5**
**Installing and Upgrading Modules 45**

Safety Warnings	45
Installing a Network Interface Module in the IR8340 Router	46
Installing Pluggable Modules	47
Installing the mSATA SSD	49
Installing SFP Modules	50
Laser Safety Guidelines	51

Installing SFP Modules 51  
 Removing SFP Modules 51

---

**CHAPTER 6**      **Antenna Selection and Installation 53**

    Antenna Selection and Installation 53  
 Antenna Installation Best Practices 53  
 Supported Antennas for the IR8340 55  
     Cellular Antennas 55  
     GPS Antennas 57  
 Supported RF Cables for the IR8340 57  
     Accessories 61

---

**CHAPTER 7**      **Cable and Connectors 63**

    Connector Specifications 63  
     10/100/1000 Ports 63  
         SFP Module Connectors 63  
     Console Port 64  
     Alarm Port 64  
 Cables and Adapters 65  
     SFP Module Cables 65  
     Console Port Adapter Pinouts 65

---

**CHAPTER 8**      **Technical Specifications 67**

    Router Specifications 67  
     Power-Supply Module Specifications 68  
     Alarm Ratings 69



# Preface

---

This preface describes the objectives, audience, organization, and conventions of this guide and describes related documents that have additional information.



---

**Note** The documentation set for this product strives to use bias-free language. For purposes of this documentation set, bias-free is defined as language that does not imply discrimination based on age, disability, gender, racial identity, ethnic identity, sexual orientation, socioeconomic status, and intersectionality. Exceptions may be present in the documentation due to language that is hardcoded in the user interfaces of the product software, language used based on RFP documentation, or language that is used by a referenced third-party product.

---

- [Objective, on page vii](#)
- [Audience, on page vii](#)
- [Conventions, on page vii](#)
- [Safety Warnings, on page viii](#)
- [Related Documentation, on page xiii](#)
- [Communications, Services, and Additional Information, on page xiv](#)

## Objective

This guide provides an overview and explains how to install and connect your Cisco device.

## Audience

This guide is intended for people who have a high level of technical ability, although they may not have experience with Cisco software.

## Conventions

This section describes the conventions used in this guide.



**Note** Means reader take note. Notes contain helpful suggestions or references to additional information and material.



**Caution** This symbol means reader be careful. In this situation, you might do something that could result in equipment damage or loss of data.



**Tip** Means *the following information will help you solve a problem* . The tip information might not be troubleshooting or even an action, but could be useful information.



**Warning** Means danger. You are in a situation that could cause bodily injury. Before you work on any equipment, be aware of the hazards involved with electrical circuitry and be familiar with standard practices for preventing accidents. Use the statement number provided at the end of each warning to locate its translation in the translated safety warnings that accompanied this device.

## Safety Warnings



**Caution** If this product will be installed in a hazardous location, read the Getting Started/Product Document of Compliance included in the package.

<p><b>Warning</b></p>	<p>This warning symbol means danger. You are in a situation that could cause bodily injury. Before you work on any equipment, be aware of the hazards involved with electrical circuitry and be familiar with standard practices for preventing accidents. Use the statement number provided at the end of each warning to locate its translation in the translated safety warnings that accompanied this device. <b>Statement 1071</b></p>
<p><b>Waarschuwing</b></p>	<p><b>BELANGRIJKE VEILIGHEIDSINSTRUCTIES</b></p> <p>Dit waarschuwingssymbool betekent gevaar. U verkeert in een situatie die lichamelijk letsel kan veroorzaken. Voordat u aan enige apparatuur gaat werken, dient u zich bewust te zijn van de bij elektrische schakelingen betrokken risico's en dient u op de hoogte te zijn van de standaard praktijken om ongelukken te voorkomen. Gebruik het nummer van de verklaring onderaan de waarschuwing als u een vertaling van de waarschuwing die bij het apparaat wordt geleverd, wilt raadplegen.</p> <p><b>BEWAAR DEZE INSTRUCTIES</b></p>



<b>Varoitus</b>	<p><b>TÄRKEITÄ TURVALLISUUSOHJEITA</b></p> <p>Tämä varoitusmerkki merkitsee vaaraa. Tilanne voi aiheuttaa ruumiillisia vammoja. Ennen kuin käsittelet laitteistoa, huomioi sähköpiirin käsittelemiseen liittyvät riskit ja tutustu onnettomuuksien yleisiin ehkäisytapoihin. Turvallisuusvaroitusten käännökset löytyvät laitteen mukana toimitettujen käännettyjen turvallisuusvaroitusten joukosta varoitusten lopussa näkyvien lausuntonumeroiden avulla.</p> <p>SÄILYTÄ NÄMÄ OHJEET</p>
<b>Attention</b>	<p><b>IMPORTANTES INFORMATIONS DE SÉCURITÉ</b></p> <p>Ce symbole d'avertissement indique un danger. Vous vous trouvez dans une situation pouvant entraîner des blessures ou des dommages corporels. Avant de travailler sur un équipement, soyez conscient des dangers liés aux circuits électriques et familiarisez-vous avec les procédures couramment utilisées pour éviter les accidents. Pour prendre connaissance des traductions des avertissements figurant dans les consignes de sécurité traduites qui accompagnent cet appareil, référez-vous au numéro de l'instruction situé à la fin de chaque avertissement.</p> <p>CONSERVEZ CES INFORMATIONS</p>
<b>Warnung</b>	<p><b>WICHTIGE SICHERHEITSHINWEISE</b></p> <p>Dieses Warnsymbol bedeutet Gefahr. Sie befinden sich in einer Situation, die zu Verletzungen führen kann. Machen Sie sich vor der Arbeit mit Geräten mit den Gefahren elektrischer Schaltungen und den üblichen Verfahren zur Vorbeugung vor Unfällen vertraut. Suchen Sie mit der am Ende jeder Warnung angegebenen Anweisungsnummer nach der jeweiligen Übersetzung in den übersetzten Sicherheitshinweisen, die zusammen mit diesem Gerät ausgeliefert wurden.</p> <p>BEWAHREN SIE DIESE HINWEISE GUT AUF.</p>
<b>Avvertenza</b>	<p><b>IMPORTANTI ISTRUZIONI SULLA SICUREZZA</b></p> <p>Questo simbolo di avvertenza indica un pericolo. La situazione potrebbe causare infortuni alle persone. Prima di intervenire su qualsiasi apparecchiatura, occorre essere al corrente dei pericoli relativi ai circuiti elettrici e conoscere le procedure standard per la prevenzione di incidenti. Utilizzare il numero di istruzione presente alla fine di ciascuna avvertenza per individuare le traduzioni delle avvertenze riportate in questo documento.</p> <p>CONSERVARE QUESTE ISTRUZIONI</p>
<b>Advarsel</b>	<p><b>VIKTIGE SIKKERHETSINSTRUKSJONER</b></p> <p>Dette advarselssymbolet betyr fare. Du er i en situasjon som kan føre til skade på person. Før du begynner å arbeide med noe av utstyret, må du være oppmerksom på farene forbundet med elektriske kretser, og kjenne til standardprosedyrer for å forhindre ulykker. Bruk nummeret i slutten av hver advarsel for å finne oversettelsen i de oversatte sikkerhetsadvarslene som fulgte med denne enheten.</p> <p>TA VARE PÅ DISSE INSTRUKSJONENE</p>

<b>Aviso</b>	<p><b>INSTRUÇÕES IMPORTANTES DE SEGURANÇA</b></p> <p>Este símbolo de aviso significa perigo. Você está em uma situação que poderá ser causadora de lesões corporais. Antes de iniciar a utilização de qualquer equipamento, tenha conhecimento dos perigos envolvidos no manuseio de circuitos elétricos e familiarize-se com as práticas habituais de prevenção de acidentes. Utilize o número da instrução fornecido ao final de cada aviso para localizar sua tradução nos avisos de segurança traduzidos que acompanham este dispositivo.</p> <p><b>GUARDE ESTAS INSTRUÇÕES</b></p>
<b>¡Advertencia!</b>	<p><b>INSTRUCCIONES IMPORTANTES DE SEGURIDAD</b></p> <p>Este símbolo de aviso indica peligro. Existe riesgo para su integridad física. Antes de manipular cualquier equipo, considere los riesgos de la corriente eléctrica y familiarícese con los procedimientos estándar de prevención de accidentes. Al final de cada advertencia encontrará el número que le ayudará a encontrar el texto traducido en el apartado de traducciones que acompaña a este dispositivo.</p> <p><b>GUARDE ESTAS INSTRUCCIONES</b></p>
<b>Varning!</b>	<p><b>VIKTIGA SÄKERHETSANVISNINGAR</b></p> <p>Denna varningssignal signalerar fara. Du befinner dig i en situation som kan leda till personskada. Innan du utför arbete på någon utrustning måste du vara medveten om farorna med elkretsar och känna till vanliga förfaranden för att förebygga olyckor. Använd det nummer som finns i slutet av varje varning för att hitta dess översättning i de översatta säkerhetsvarningar som medföljer denna anordning.</p> <p><b>SPARA DESSA ANVISNINGAR</b></p>
<b>Figyelem</b>	<p><b>FONTOS BIZTONSÁGI ELOÍRÁSOK</b></p> <p>Ez a figyelmeztető jel veszélyre utal. Sérülésveszélyt rejtő helyzetben van. Mielőtt bármely berendezésen munkát végezte, legyen figyelmes az elektromos áramkörök okozta kockázatokra, és ismerkedjen meg a szokásos balesetvédelmi eljárásokkal. A kiadványban szereplő figyelmeztetések fordítása a készülékhez mellékelt biztonsági figyelmeztetések között található; a fordítás az egyes figyelmeztetések végén látható szám alapján kereshető meg.</p> <p><b>ORIZZE MEG EZEKET AZ UTASÍTÁSOKAT!</b></p>
<b>Предупреждение</b>	<p><b>ВАЖНЫЕ ИНСТРУКЦИИ ПО СОБЛЮДЕНИЮ ТЕХНИКИ БЕЗОПАСНОСТИ</b></p> <p>Этот символ предупреждения обозначает опасность. То есть имеет место ситуация, в которой следует опасаться телесных повреждений. Перед эксплуатацией оборудования выясните, каким опасностям может подвергаться пользователь при использовании электрических цепей, и ознакомьтесь с правилами техники безопасности для предотвращения возможных несчастных случаев. Воспользуйтесь номером заявления, приведенным в конце каждого предупреждения, чтобы найти его переведенный вариант в переводе предупреждений по безопасности, прилагаемом к данному устройству.</p> <p><b>СОХРАНИТЕ ЭТИ ИНСТРУКЦИИ</b></p>
<b>警告</b>	<p><b>重要的安全性说明</b></p> <p>此警告符号代表危险。您正处于可能受到严重伤害的工作环境中。在您使用设备开始工作之前，必须充分意识到触电的危险，并熟练掌握防止事故发生的标准工作程序。请根据每项警告结尾提供的声明号码来找到此设备的安全性警告说明的翻译文本。</p> <p><b>请保存这些安全性说明</b></p>
<b>警告</b>	<p><b>安全上の重要な注意事項</b></p> <p>「危険」の意味です。人身事故を予防するための注意事項が記述されています。装置の取り扱い作業を行うときは、電気回路の危険性に注意し、一般的な事故防止策に留意してください。警告の各国語版は、各注意事項の番号を基に、装置に付属の「Translated Safety Warnings」を参照してください。</p> <p><b>これらの注意事項を保管しておいてください。</b></p>
<b>주의</b>	<p><b>중요 안전 지침</b></p> <p>이 경고 기호는 위험을 나타냅니다. 작업자가 신체 부상을 일으킬 수 있는 위험한 환경에 있습니다. 장비에 작업을 수행하기 전에 전기 회로와 관련된 위험을 숙지하고 표준 작업 관례를 숙지하여 사고를 방지하십시오. 각 경고의 마지막 부분에 있는 경고문 번호를 참조하여 이 장치와 함께 제공되는 번역된 안전 경고문에서 해당 번역문을 찾으십시오.</p> <p><b>이 지시 사항을 보관하십시오.</b></p>

Aviso	<p><b>INSTRUÇÕES IMPORTANTES DE SEGURANÇA</b></p> <p>Este símbolo de aviso significa perigo. Você se encontra em uma situação em que há risco de lesões corporais. Antes de trabalhar com qualquer equipamento, esteja ciente dos riscos que envolvem os circuitos elétricos e familiarize-se com as práticas padrão de prevenção de acidentes. Use o número da declaração fornecido ao final de cada aviso para localizar sua tradução nos avisos de segurança traduzidos que acompanham o dispositivo.</p> <p><b>GUARDE ESTAS INSTRUÇÕES</b></p>
Advarsel	<p><b>VIGTIGE SIKKERHEDSANVISNINGER</b></p> <p>Dette advarselssymbol betyder fare. Du befinder dig i en situation med risiko for legemesbeskadigelse. Før du begynder arbejde på udstyr, skal du være opmærksom på de involverede risici, der er ved elektriske kredsløb, og du skal sætte dig ind i standardprocedurer til undgåelse af ulykker. Brug erklæringsnummeret efter hver advarsel for at finde oversættelsen i de oversatte advarsler, der fulgte med denne enhed.</p> <p><b>GEM DISSE ANVISNINGER</b></p>
تحذير	<p><b>إرشادات الأمان الهامة</b></p> <p>يوضح رمز التحذير هذا وجود خطر. وهذا يعني أنك متواجد في مكان قد ينتج عنه التعرض للإصابات. قبل بدء العمل، احذر مخاطر التعرض للصدمة الكهربائية وكن على علم بالإجراءات القياسية للحيلولة دون وقوع أي حوادث. استخدم رقم البيان الموجود في آخر كل تحذير لتحديد مكان ترجمته داخل تحذيرات الأمان المترجمة التي تأتي مع الجهاز. قم بحفظ هذه الإرشادات</p>
Upozorenje	<p><b>VAŽNE SIGURNOSNE NAPOMENE</b></p> <p>Ovaj simbol upozorenja predstavlja opasnost. Nalazite se u situaciji koja može prouzročiti fizične ozljede. Prije rada s bilo kojim uređajem, morate razumjeti opasnosti vezane uz električne sklopove, te biti upoznat/na standardnim načinima izbjegavanja nesreća. U preveđenim sigurnosnim upozorenjima, priloženima uz uređaj, možete prema broju koji se nalazi uz pojedino upozorenje pronaći i njegov prijevod.</p> <p><b>SACHUVAJTE OVE UPUTE</b></p>
Upozornění	<p><b>DŮLEŽITÉ BEZPEČNOSTNÍ POKYNY</b></p> <p>Tento upozorňující symbol označuje nebezpečí. Jste v situaci, která by mohla způsobit nebezpečí úrazu. Před prací na jakémkoliv vybavení si uvědomte nebezpečí související s elektrickými obvody a seznámte se se standardními opatřeními pro předcházení úrazům. Podle čísla na konci každého upozornění vyhledejte jeho překlad v přiložených bezpečnostních upozorněních, která jsou přiložena k zařízení.</p> <p><b>USCHOVEJTE TYTO POKYNY</b></p>
Προειδοποίηση	<p><b>ΣΗΜΑΝΤΙΚΕΣ ΟΔΗΓΙΕΣ ΑΣΦΑΛΕΙΑΣ</b></p> <p>Αυτό το προειδοποιητικό σύμβολο σημαίνει κίνδυνο. Βρίσκεστε σε κατάσταση που μπορεί να προκαλέσει τραυματισμό. Πριν εργαστείτε σε οποιοδήποτε εξοπλισμό, να έχετε υπόψη σας τους κινδύνους που σχετίζονται με τα ηλεκτρικά κυκλώματα και να έχετε εξοικειωθεί με τις συνήθεις πρακτικές για την αποφυγή ατυχημάτων. Χρησιμοποιήστε τον αριθμό δηλώσεως που παρέχεται στο τέλος κάθε προειδοποίησης, να να εντοπίσετε τη μετάφρασή της στις μεταφρασμένες προειδοποιήσεις ασφαλείας που συνοδεύουν τη συσκευή.</p> <p><b>ΦΥΛΑΣΤΕ ΑΥΤΕΣ ΤΙΣ ΟΔΗΓΙΕΣ</b></p>
אזהרה	<p><b>הוראות בטיחות חשובות</b></p> <p>סמל אזהרה זה מסמל סכנה. אתם נמצאים במצב העלול לגרום לפציעה. לפני שתעבוד עם יודי כלשהו, עליך להיות מודע לסכנות הכרוכות במעלים חשמליים ולהכיר את הנהלים המקובלים למניעת תאונות. השתמש במספר ההוראה המסופק בסופה של כל אזהרה כדי לאתר את התרגום באזהרות הבטיחות המתורגמות שמצורפות להתקן.</p> <p><b>שמור הוראות אלה</b></p>
Opomena	<p><b>ВАЖНИ БЕЗБЕДНОСНИ НАПАТСТВИЈА</b></p> <p>Симболот за предупредување значи опасност. Се наоѓате во ситуација што може да предизвика телесни повреди. Пред да работите со опремата, бидете свесни за ризикот што постои кај електричните кола и треба да ги познавате стандардните постапки за спречување на несреќни случаи. Искористете го бројот на изјавата што се наоѓа на крајот на секое предупредување за да го најдете неговот период во преведените безбедносни предупредувања што се испорачани со уредот.</p> <p><b>ЧУВАЈТЕ ГИ ОБИЕ НАПАТСТВИЈА</b></p>
Ostrzeżenie	<p><b>WAŻNE INSTRUKCJE DOTYCZĄCE BEZPIECZEŃSTWA</b></p> <p>Ten symbol ostrzeżenia oznacza niebezpieczeństwo. Zachodzi sytuacja, która może powodować obrażenia ciała. Przed przystąpieniem do prac przy urządzeniach należy zapoznać się z zagrożeniami związanymi z układami elektrycznymi oraz ze standardowymi środkami zapobiegania wypadkom. Na końcu każdego ostrzeżenia podano numer, na podstawie którego można odszukać tłumaczenie tego ostrzeżenia w dotychczasowym do urządzenia dokumentcie z tłumaczeniami ostrzeżeń.</p> <p><b>NINIEJSZE INSTRUKCJE NALEŻY ZACHOWAĆ</b></p>

<p><b>Upozornenie</b></p>	<p><b>DŮLEŽITÉ BEZPEČNOSTNÉ POKYNY</b></p> <p>Tento varovný symbol označuje nebezpečenstvo. Nachádzate sa v situácii s nebezpečenstvom úrazu. Pred prácou na akomkoľvek vybavení si uvedomte nebezpečenstvo súvisiace s elektrickými obvodmi a oboznámte sa so štandardnými opatreniami na predchádzanie úrazom. Podľa čísla na konci každého upozornenia vyhľadajte jeho preklad v preložených bezpečnostných upozorneniach, ktoré sú priložené k zariadeniu.</p> <p><b>USCHOVAJTE SI TENTO NÁVOD</b></p>
<p><b>Opozorilo</b></p>	<p>Ta naprava mora biti ozemljena. Nikoli ne odklapljajte ozemljitve oz. upravljajte naprave, ki ni primerno ozemljena. V primeru, da niste sigurni, ali imate primerno ozemljenje, nemudoma pokličite pooblaščen električni servis ali električarja.</p>
<p><b>警告</b></p>	<p>重要安全性指示 此警告符號代表危險，表示可能造成人身傷害，使用任何設備前，請留心電路相關危險，並熟悉避免意外的標準作法。您可以使用每項警告後的聲明編號，查詢本裝置隨附之安全性警告譯文中文的翻譯。請妥善保留此指示</p>



**Warning**

When installing the product, please use the provided or designated connection cables/power cables/AC adapters. Using any other cables/adapters could cause a malfunction or a fire. Electrical Appliance and Material Safety Law prohibits the use of UL-certified cables (that have the “UL” shown on the code) for any other electrical devices than products designated by CISCO. The use of cables that are certified by Electrical Appliance and Material Safety Law (that have “PSE” shown on the code) is not limited to CISCO-designated products. **Statement 371**



**Warning**

Read the wall-mounting instructions carefully before beginning installation. Failure to use the correct hardware or to follow the correct procedures could result in a hazardous situation to people and damage to the system. **Statement 378**



**Warning**

Read the installation instructions before connecting the system to the power source. **Statement 1004**



**Warning**

Class 1 laser product. **Statement 1008**



**Warning**

To avoid electric shock, do not connect safety extra-low voltage (SELV) circuits to telephone-network voltage (TNV) circuits. LAN ports contain SELV circuits, and WAN ports contain TNV circuits. Some LAN and WAN ports both use RJ-45 connectors. Use caution when connecting cables. **Statement 1021**



**Warning**

This equipment must be grounded. Never defeat the ground conductor or operate the equipment in the absence of a suitably installed ground conductor. Contact the appropriate electrical inspection authority or an electrician if you are uncertain that suitable grounding is available. **Statement 1024**



---

**Warning** When installing or replacing the unit, the ground connection must always be made first and disconnected last. **Statement 1046**

---



---

**Warning** Do not locate the antenna near overhead power lines or other electric light or power circuits, or where it can come into contact with such circuits. When installing the antenna, take extreme care not to come into contact with such circuits, because they may cause serious injury or death. For proper installation and grounding of the antenna, please refer to national and local codes (for example, U.S.:NFPA 70, National Electrical Code, Article 810, Canada: Canadian Electrical Code, Section 54). **Statement 1052**

---



---

**Warning** No user-serviceable parts inside. Do not open. **Statement 1073**

---



---

**Warning** Installation of the equipment must comply with local and national electrical codes. **Statement 1074**

---



---

**Warning** Only trained and qualified personnel should be allowed to install, replace, or service this equipment. **Statement 1030**

---



---

**Warning** Ultimate disposal of this product should be handled according to all national laws and regulations. **Statement 1040**

---



---

**Warning** The covers are an integral part of the safety design of the product. Do not operate the unit without the covers installed. **Statement 1077**

---



---

**Warning** Hot surface. **Statement 1079**

---

## Related Documentation

All of the IR8340 documentation can be found online here:

<https://www.cisco.com/c/en/us/support/routers/catalyst-ir8300-rugged-series-router/series.html>

## Communications, Services, and Additional Information

- To receive timely, relevant information from Cisco, sign up at [Cisco Profile Manager](#).
- To get the business impact you're looking for with the technologies that matter, visit [Cisco Services](#).
- To submit a service request, visit [Cisco Support](#).
- To discover and browse secure, validated enterprise-class apps, products, solutions, and services, visit [Cisco DevNet](#).
- To obtain general networking, training, and certification titles, visit [Cisco Press](#).
- To find warranty information for a specific product or product family, access [Cisco Warranty Finder](#).

## Cisco Bug Search Tool

[Cisco Bug Search Tool](#) (BST) is a gateway to the Cisco bug-tracking system, which maintains a comprehensive list of defects and vulnerabilities in Cisco products and software. The BST provides you with detailed defect information about your products and software.

## Documentation Feedback

To provide feedback about Cisco technical documentation, use the feedback form available in the right pane of every online document.



# CHAPTER 1

## Product Overview

Cisco Catalyst IR8340 Rugged Series Router is an industrial grade routing platform with higher port density, higher throughput, native FOG computing, compute capabilities, and enhanced security functionalities.

These topics are discussed:

- [Chassis Views, on page 1](#)
- [Hardware Features, on page 1](#)
- [Power Supply Side View, on page 13](#)

## Chassis Views

The IR8340 router chassis is designed to accommodate Pluggable Interface Module (PIM), Industrial Router Network Interface Module (IRM-NIM), mSATA module, and Timing module.

This section has views of the IR8340 router, showing locations of the interfaces, module slots, status indicators, and chassis identification labels. The following figure shows the Cisco IR8340 Router chassis.

*Figure 1: IR8340 Router Chassis*



## Hardware Features

This section describes the hardware features of the IR8340 router.

Figure 2: IR8340 Router Front Panel

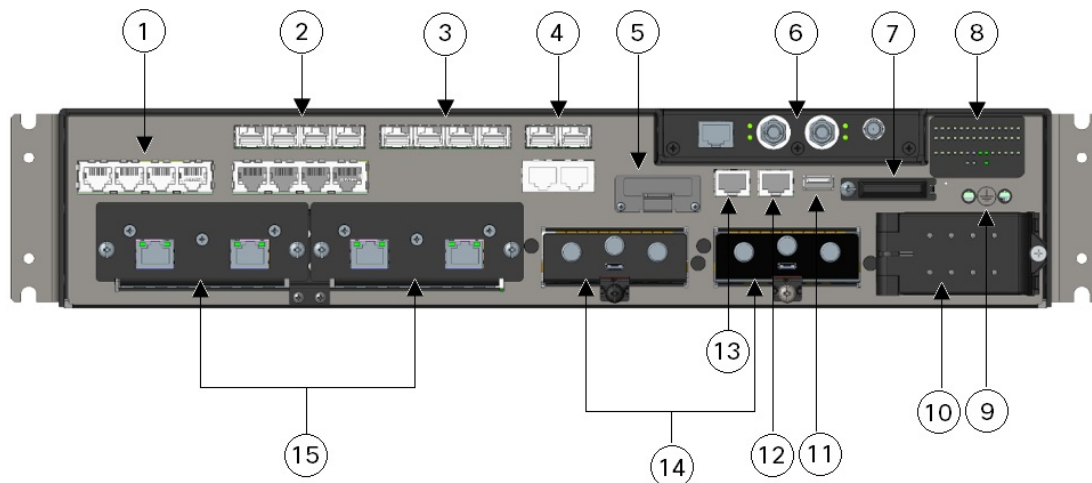

1	Four 10/100/1000Base-T PoE/PoE+/UPoE LAN ports	9	Grounding point
2	Four 100/1000 SFP LAN ports (top) Four 10/100/1000 Base-T LAN ports (bottom)	10	Power input terminal
3	Four 100/1000 SFP LAN ports	11	USB port
4	Two 100/1000 SFP WAN ports (top) Two 10/100/1000 Base-T WAN ports (bottom)	12	Console port
5	mSATA module slot	13	Alarm port
6	Timing module slot	14	Two PIM slots
7	SD flash card slot	15	Two IRM-NIM slots
8	System and port LEDs		

## Alarm Ports

The router has two alarm inputs and one alarm output.

### Alarm Input

The alarm input is a dry-contact alarm port. You can connect up to two alarm inputs from devices, such as a door, a temperature gauge, or a fire alarm, to the alarm port. You can use the CLI to set the alarm severity to minor, or major. An alarm generates a system message and turns on an LED. See [Cable Side View LEDs](#), on [page 11](#) for the LED descriptions.



## Alarm Output

The alarm output can be configured as a major alarm. Output alarms often control an external alarm, such as a bell or a light. To connect an external alarm device to the relay, you connect two relay contact wires to complete the electrical circuit. For information on the alarm pinouts, see [Alarm Port, on page 64](#).

## Console Port

You can connect the router to a PC running Microsoft Windows or to a terminal server through the RJ-45 console port. The RJ-45 connection uses an RJ-45-to-DB-9 female cable.

## Power-Input Terminal

The power-input terminal provides screw terminals for the AC and DC power connections. The router can operate with one or two power supplies. If one of the power sources fail, the other continues to power the router. See [Power Supply Installation, on page 33](#) for more information.

## 100/1000 SFP Ports (Uplinks)

The uplink ports support 100M optics and 1G optics. When using a 1000BaseT SFP, the port only operates at 1000 mbps.

## 100/1000 SFP Ports (Downlinks)

The router Ethernet SFP modules provide connections to other devices. These field-replaceable transceiver modules provide the downlink interfaces. The IR8340 router supports both FE and GE optics in the downlinks. SFP modules have local connectors (LCs) for fiber-optic connections.

For information about SFP modules, see your SFP module documentation. For more information about SFP modules and cables, see [Transceiver Modules](#).

The small form factor pluggable (SFP) ports on the Cisco IR8340 router support the following SFP modules:

**Table 1: Supported SFP Modules**

Part Number	Type of SFP Module
GLC-SX-MM-RGD	Industrial temperature range (IND): -40 to 85°C (-40 to 185°F)
GLC-LX-SM-RGD	
GLC-ZX-SM-RGD	
GLC-FE-100LX-RGD	
GLC-FE-100FX-RGD	
GLC-T-RGD	

Part Number	Type of SFP Module
GLC-BX-U GLC-BX-D GLC-FE-100BX-D GLC-FE-100BX-U GLC-FE-100FX GLC-FE-100LX GLC-FE-100EX GLC-FE-100ZX CWDM-SFP-xxxx DWDM-SFP-xxxx	Commercial SFPs  Commercial temperature range (COM): 0 to 70°C (32 to 158°F)
GLC-SX-MMD GLC-LH-SMD GLC-EX-SMD GLC-ZX-SMD GLC-TE	Extended temperature range (EXT): -5 to 85°C (23 to 185°F)

## 10/100/1000 PoE/PoE+/UPoE Ports (Downlinks)

You can set the 10/100/1000 ports on the router to operate in any combination of half duplex, full duplex, or 10/100/1000 Mb/s. You can set the ports for speed and duplex autonegotiation. The default setting is autonegotiate.

When set for autonegotiation, the router determines the speed and duplex settings of the attached device and advertises its own capabilities. If the connected device also supports autonegotiation, the router negotiates the best connection (the fastest line speed that both devices support and full-duplex transmission if the attached device supports it) and configures itself accordingly. In all cases, the attached device must be within 328 feet (100 meters).



**Warning** Voltages that present a shock hazard may exist on Power over Ethernet (PoE) circuits if interconnections are made using uninsulated exposed metal contacts, conductors, or terminals. Avoid using such interconnection methods, unless the exposed metal parts are located within a restricted access location and users and service people who are authorized within the restricted access location are made aware of the hazard. A restricted access area can be accessed only through the use of a special tool, lock and key or other means of security. Statement 1072

The 10/100/1000 PoE ports on the router provide PoE support for devices that are compliant with IEEE 802.3af/802.3at. The Cisco prestandard PoE is also supported for Cisco IP Phones and Cisco Aironet Access Points. The PoE ports on the router deliver up to 30 W of PoE+ power. All four ports are PoE ports and can be assigned a port priority.

On IR8340, GigabitEthernet 0/1/0 and GigabitEthernet 0/1/1 support POE/POE+/UPOE, GigabitEthernet 0/1/2 and GigabitEthernet 0/1/3 support POE/POE+ only.

On a per-port basis, you control whether or not a port automatically provides power when an IP phone or an access point is connected.

The 10/100/1000 PoE ports use RJ-45 connectors with Ethernet pinouts. The maximum cable length is 328 feet (100 meters). The 100BASE-TX and 1000BASE-T traffic requires CAT5, CAT5e, or CAT6 shielded twisted-pair (STP) cable. The 10BASE-T traffic can use CAT3 or CAT4 shielded twisted pair (STP) cable.

For information about configuring and monitoring PoE ports, see the router software configuration guide on Cisco.com.



---

**Note** The output of the PoE circuit has been evaluated as a Limited Power Source (LPS) per IEC 60950-1.

---

## mSATA Module

Mini-SATA, or mSATA, is a low-profile interface connector that enables more effective Serial ATA (SATA) integration in small form-factor drives roughly the size of a business card, such as solid state disks (SSDs). The Cisco IR8340 router provides an expand slot to accommodate the mSATA module (PID: IRM-SSD-100G). The following figure shows the mSATA Pluggable Module.

*Figure 3: mSATA Module*

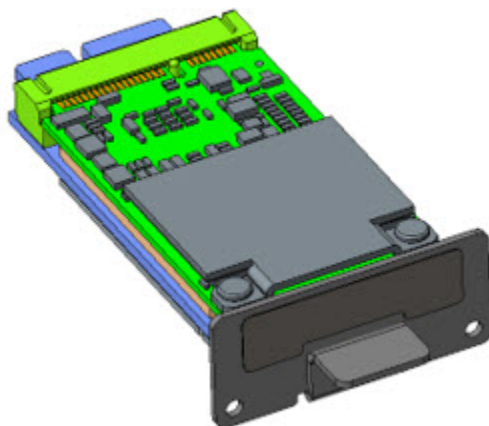

Highlights of the mSATA Pluggable Module are:

- Provides an additional 100 GB of additional flash memory storage
- Field replaceable unit, not hot-swappable

## Timing Module

The IR8340 router supports a pluggable timing module (Cisco PID: IRM-TIMING-MOD), which has the following timing ports:

- ToD + 1 PPS Output—Provide time of day (ToD) messages or one pulse-per-second (1 PPS) messages
- IRIG-B (analog and digital Input/Output) interfaces
- GNSS Receiver

**Figure 4: IRM-TIMING-MOD Timing Module**



Timing card is pluggable but does not support OIR operation. The module has to be plugged in when the IR8340 is fully shut down.

## SD Flash Memory Card

The Cisco IR8340 router supports a flash memory card that makes it possible to replace a failed router without reconfiguring the new router. The slot for the flash memory card is on the front of the router. The flash card is hot swappable and can be accessed on the front panel in non hazardous locations only. A cover protects the flash card and holds the card firmly in place. The cover is hinged and closed with a captive screw. This prevents the card from coming loose and protects against shock and vibration.

For more information on inserting and removing the flash memory card, see [Replacing the SD Flash Memory Card, on page 29](#).

## Network Interface Modules

The Network Interface Modules (NIMs) support data applications on the Cisco IR8340 router.

The following NIMs are supported:

- IRM-NIM-2T1E1—2 ports T1/E1 module, provides T1/E1 connectivity to the router.
- IRM-NIM-RS232—8 ports async/sync RS232 serial module, provides serial connectivity to the router.

## Cisco Pluggable Modules

The Pluggable Module provides the flexibility of adding different interfaces to the IR8340 router, for example, a cellular module.

The IR8340 router supports the following Pluggable Modules:

- P-LTE-MNA
- P-LTEA-EA
- P-LTEA-LA

- P-LTEAP18-GL
- P-5GS6-GL

## Pluggable LTE Module

Highlights of the LTE Pluggable Module are:

- All Cellular interfaces are supported through a pluggable module.
- Micro-Sim, 3FF size. Cisco recommends Industrial Temp micro SIMs that are rated from -40 to +105°C.

The following two figures show an example of a pluggable module. In this case, the LTE Pluggable Module.

**Figure 5: PIM Module**

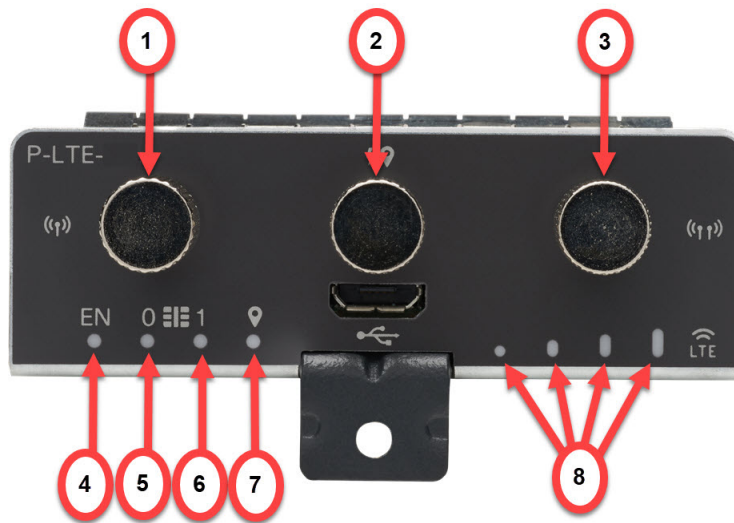

1	Cellular-Main SMA	5	SIM 0 LED
2	GPS SMA	6	SIM 1 LED
3	Cellular-Div SMA	7	GPS LED
4	Enable LED	8	RSSI LEDs

Figure 6: LTE Pluggable Module (With Antennas)



## LTE Category 18 Pluggable Module

This module has a new smaller form factor SMA Diversity Antenna for usability and Micro-USB port access.

Figure 7: LTE Pluggable P-LTEA18-GL

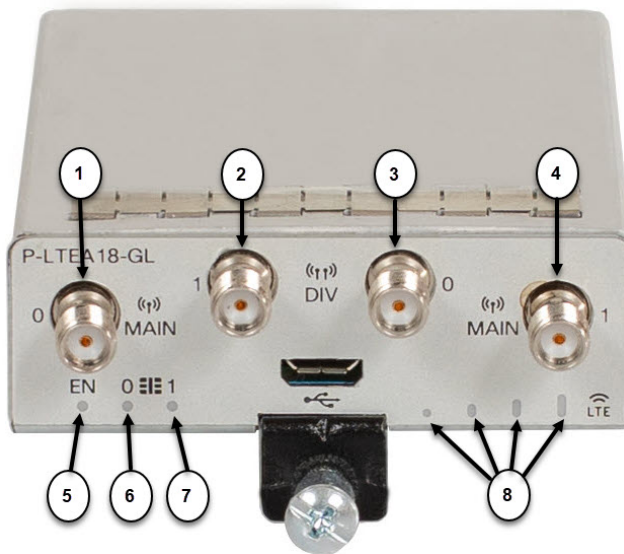

1	Main 0 Antenna	5	Enable LED
2	Diversity 1 Antenna	6	SIM 0 LED
3	Diversity 0 Antenna	7	SIM 1 LED
4	Main 1 Antenna	8	RSSI LEDs

### P-LTEAP18-GL Frequency Bands

The following table provides the global frequency bands available.



**Note** Antennas must be attached to the RF connectors as listed below for proper bands service.

Item	Description
MAIN 0 and DIV 0	B1, B2(B25), B3, B4(B66), B5(B26,B18,B19), B8, B12(B17), B13, B14, B20, B28, B29, B39, B71, B41
MAIN 1 and DIV 1	B7, B30, B32, B38, B40, B41, B42, B46, B48, B2(B25)

### 5G Pluggable Interface Module

The 5G Sub-6 GHz Pluggable Interface Module offers 5G capability to the IoT Industrial Router family. The product ID for the pluggable module is P-5GS6-GL. The P-5GS6-GL uses the FN980 Telit modem.



**Note** IOS XE release 17.8.1 is the first software release to provide support for the P-5GS6-GL on IR8340 router.

The following features and limitations apply across all IoT routing platforms unless specifically mentioned:

- IoT routing platforms support a maximum of two pluggable modules, with a combination of 5G and 4G PIMs.
- The pluggable module can be started or stopped through the CLI under exec mode. Also, it can be configured to power off the module to reduce power consumption as needed.
- The capability to disable FDD Band 30 for vehicular applications is available.

The following figure shows the P-5GS6-GL pluggable module:

Figure 8: 5G Pluggable Interface Module - P-5GS6-GL

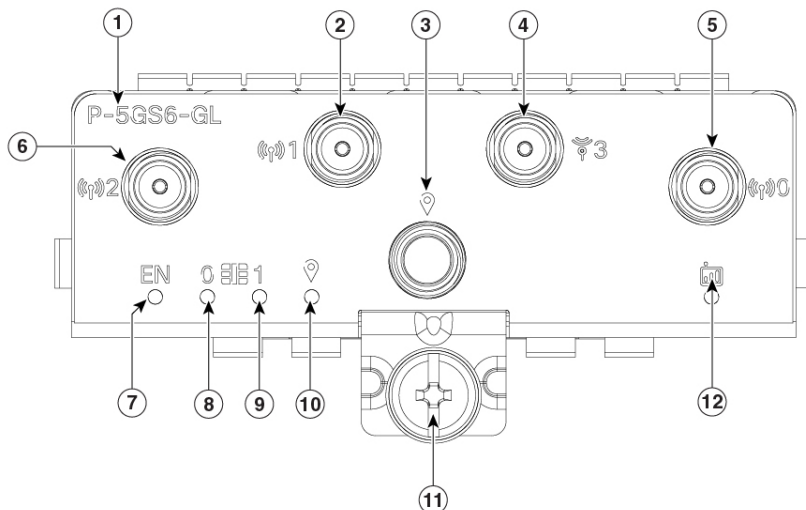

1	PID	7	Enable LED
2	Antenna 1 (SMA)	8	SIM 0 LED
3	GPS (SMA)	9	SIM 1 LED
4	Antenna 3 (SMA)	10	GPS LED
5	Antenna 0 (SMA)	11	M3.5 thumb-screw
6	Antenna 2 (SMA)	12	Service LED

For more information on P-5GS6-GL module, see the [5G Sub-6 GHz Pluggable Interface Module](#) chapter of *Cisco Catalyst IR1800 Rugged Series Router Hardware Installation Guide*.

## Supported Cisco Antennas and Antenna Accessories

The IR8340 must have a Pluggable Module with antenna ports installed in order to connect antennas. The base unit does not have any wireless capabilities on its own.

The Antenna Selection and Installation chapter lists the supported Antennas and Accessories for the Cisco IR8340 router with a wireless Pluggable Module. For detailed information about Cisco Antennas for the Industrial Routers, please refer to [Cisco Industrial Routers and Industrial Wireless Access Points Antenna Guide](#).

## LEDs

You can use the system and port LEDs to monitor router activity and performance.



## Cable Side View LEDs

Figure 9: LEDs

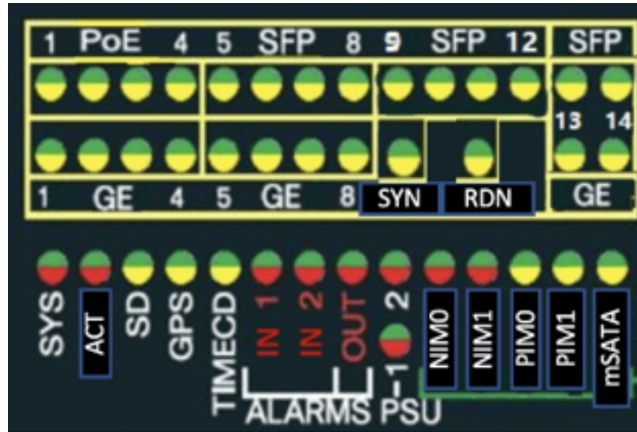

The following table describes the IR8340 router LED indicators.

Table 2: Cisco IR8340 Router LED Indicators

LED	Port LED Color	Description
SYS	Off	Power is off.
	Solid green	Normal operation.
	Blinking green	POST in progress.
	Solid red	Power is on but malfunctioning.
ACT	Solid or blinking green	Solid or blinking indicates packet activity between the forwarding and routing engine and any I/O port.
	Off	No activity.
IRM-NIM 0 IRM-NIM 1	Green	Present and operating.
	Red	Any port on the module presents failure.
	Off	Not present or not powered.
PIM 0 PIM 1	Green	Present and operating.
	Amber	Any port on the module presents failure.
	Off	Not present or not powered.

LED	Port LED Color	Description
Port Link	Off	No link.
	Green	Link up. No activity.
	Blinking green	Link up with active traffic.
	Alternating green/amber	SFP not supported or link fault.
	Amber	Port disabled.
PSU 1 PSU 2	Green	Valid input is present, and the output is within the operating range.
	Red	Valid input is present, and the output is outside the operating range or is not present.
	Blinking red	Power-supply module (1 or 2) is installed but valid input is not present.
	Off	Power-supply module (1 or 2) is not installed.
SD	Fast blinking amber	Unsupported SD flash memory card is detected.
	Slow blinking amber	SD flash memory card is not present.
	Solid green	SD flash memory card is functioning.
	Solid amber	Error accessing SD flash card. No IOS boot image found.
	Blinking green	SD flash memory card transfer in progress.
GPS	Solid green	Active with satellite fix.
	Blinking green	Attempting to acquire satellite fix.
	Blinking amber	Antenna fault.
	Off	GPS is not configured.
ALARMS IN 1-2	Green	No alarm.
	Solid red	Major alarm present.
	Blinking red	Critical alarm present.

LED	Port LED Color	Description
ALARMS OUT	Solid green	No alarm.
	Solid red	Relay closed. Alarm present.
mSATA	Off	The mSATA module is not detected.
	Green	The mSATA module is present and enabled.
	Amber	Initialized with error.
T-code (Timecode)	Off	Timing card not detected.
	Solid green	Timecode input signal present.
	Alternating green/amber	Signal present with errors.
	Blinking amber	Timecode input configured, but no signal present.
REDUN (Redundancy Status)	Solid green	Redundancy protocols are configured and active.
	Solid amber	Redundancy fault detected.
SYNC (SyncE Status)	Off	Free run.
	Solid green	System is synced to an external source.
	Solid amber	One or more configured timing sources has a fault or is not present.
PoE Port LED (Port PoE/PoE+/UPOE)	Off	PoE/PoE+/UPOE is disabled.
	Green	Port is delivering power.
	Amber	PoE is enabled with failure.

## Power Supply Side View

The power-supply side has the LED panel and two power-supply slots for the removable power supplies.

Figure 10: IR8340 Router With Both Power Supply Modules

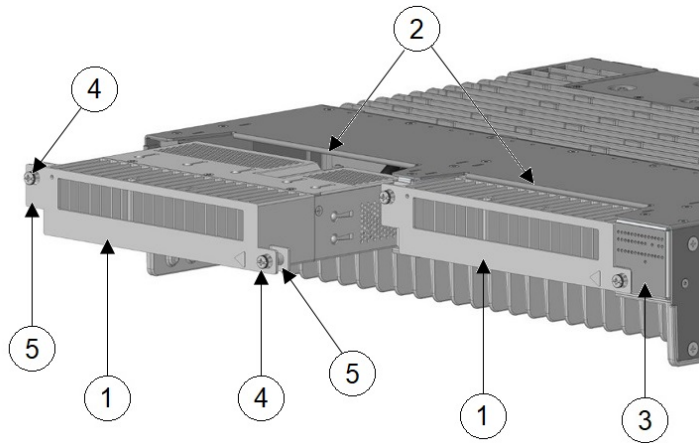

1	Power supply modules	2	Power supply slots
3	LED panel	4	Captive screws
5	Alignment tabs		

## Power Supply Features

The router has two slots for power-supply modules and supports the following power supplies:

- PWR-RGD-LOW-DC: low-voltage DC, 24 to 60VDC input, 150 watt output
- PWR-RGD-AC-DC: high-voltage AC or DC, 100 to 240VAC/100-250VDC input, 150 watt output
- PWR-RGD-AC-DC-250: high-voltage AC or DC, 100 to 240VAC/100 to 250VDC input, 250 watt output



**Note** For detailed specifications, see the IR8340 data sheet.

The router supports these power-supply module combinations:

- Single low-voltage DC
- Single high-voltage DC or AC
- Two high-voltage DC or AC
- Two low-voltage DC
- One high-voltage DC or AC and one low-voltage DC



## CHAPTER 2

# Preparing for Router Installation

This section provides preinstallation information such as recommendations and requirements to review prior to installing your router.

- [Safety Recommendations, on page 15](#)
- [General Site Requirements, on page 16](#)
- [Rack Requirements, on page 17](#)
- [Router Environmental Requirements, on page 17](#)
- [Power Guidelines and Requirements, on page 17](#)
- [Network Cabling Specifications, on page 18](#)
- [Required Tools and Equipment for Installation and Maintenance, on page 20](#)

## Safety Recommendations

Follow these guidelines to ensure general safety:

- Keep the chassis area clear and dust-free during and after installation.
- Keep tools and chassis components away from walk areas.
- Do not wear loose clothing that could get caught in the chassis. Fasten your tie or scarf and roll up your sleeves.
- Wear safety glasses when working under conditions that might be hazardous to your eyes.
- Do not perform any action that creates a hazard to people or makes the equipment unsafe.

## Safety with Electricity

Follow these guidelines when working on equipment powered by electricity:

- Locate the emergency power-off switch in the room in which you are working. If an electrical accident occurs, you can quickly turn off the power.
- Disconnect all power before doing the following:
  - Installing or removing a chassis
  - Working near power supplies
- Look carefully for possible hazards in your work area, such as moist floors, ungrounded power extension cables, frayed power cords, and missing safety grounds.
- Do not work alone if hazardous conditions exist.

- Never assume that power is disconnected from a circuit. Always check.
- Never open the enclosure of the router's internal power supply.
- If an electrical accident occurs, proceed as follows:
  - Use caution; do not become a victim yourself.
  - Turn off power to the device.
  - If possible, send another person to get medical aid. Otherwise, assess the victim's condition and then call for help.
  - Determine if the person needs rescue breathing or external cardiac compressions; then take appropriate action.



**Warning** This unit might have more than one power supply connection. All connections must be removed to de-energize the unit. Statement 1028

---



**Warning** Do not work on the system or connect or disconnect cables during periods of lightning activity. Statement 1001

---



**Warning** Read the installation instructions before connecting the system to the power source. Statement 1004

---

## Preventing Electrostatic Discharge Damage

Electrostatic discharge (ESD) can damage equipment and impair electrical circuitry. It can occur if electronic printed circuit cards are improperly handled and can cause complete or intermittent failures. Always follow ESD prevention procedures when removing and replacing modules:

- Ensure that the router chassis is electrically connected to earth ground.
- Wear an ESD-preventive wrist strap, ensuring that it makes good skin contact. Connect the clip to an unpainted surface of the chassis frame to channel unwanted ESD voltages safely to ground. To guard against ESD damage and shocks, the wrist strap and cord must operate effectively.
- If no wrist strap is available, ground yourself by touching a metal part of the chassis.



**Caution** For the safety of your equipment, periodically check the resistance value of the antistatic strap. It should be between 1 and 10 megohms (Mohm).

---

## General Site Requirements

This section describes the requirements your site must meet for safe installation and operation of your router. Ensure that the site is properly prepared before beginning installation. If you are experiencing shutdowns or unusually high errors with your existing equipment, this section can also help you isolate the cause of failures and prevent future problems.

## Rack Requirements

The following information will help you plan your equipment rack configuration:

- Allow clearance around the rack for maintenance.
- Allow at least one rack unit of vertical space between routers.
- Enclosed racks must have adequate ventilation. Ensure that the rack is not congested, because each router generates heat. An enclosed rack should have louvered sides and a fan to provide cooling air. Heat generated by equipment near the bottom of the rack can be drawn upward into the intake ports of the equipment above.

## Router Environmental Requirements

Mount the Cisco IR8340 routers in a rack. The location of your router and the layout of your equipment rack or wiring room are extremely important considerations for proper operation. Equipment placed too close together, inadequate ventilation, and inaccessible panels can cause malfunctions and shutdowns, and can make maintenance difficult. Plan for access to both power supply side and cable side panels of the router.



---

**Note** Allow at least one rack unit of vertical space above the router.

---

When planning your site layout and equipment locations, refer to [General Site Requirements, on page 16](#). If you are currently experiencing shutdowns or an unusually high number of errors with your existing equipment, these precautions and recommendations may help you isolate the cause of failure and prevent future problems.

- Ensure that the room where your router operates has adequate air circulation. Electrical equipment generates heat. Without adequate air circulation, ambient air temperature may not cool equipment to acceptable operating temperatures.
- Always follow ESD-prevention procedures described in [Preventing Electrostatic Discharge Damage, on page 16](#) to avoid damage to equipment. Damage from static discharge can cause immediate or intermittent equipment failure.
- Ensure that the chassis cover and module cable side panels are secure. All empty interface card slots and power supply bays must have filler panels installed.
- When equipment installed in a rack (particularly in an enclosed rack) fails, try operating the equipment by itself, if possible. Power off other equipment in the rack (and in adjacent racks) to allow the router under test a maximum of cooling air and clean power.

## Power Guidelines and Requirements

Check the power at your site to ensure that you are receiving “clean” power (free of spikes and noise). Install a power conditioner if necessary.

The AC power supply includes the autoselect feature for either 110 V or 220 V operation.

**Caution**

Two types of power supplies are supported on the Cisco IR8340: a low-voltage DC power supply and a high-voltage DC/AC power supply. Take caution when selecting the correct input voltage for the power supply installed or damage will result.

## Network Cabling Specifications

The following sections describe the cables needed to install your Cisco IR8340 router:

### Console Port Connection

The Cisco IR8340 router includes an EIA/TIA-232 asynchronous (RJ-45) console port. The console port provides access to the router locally using a console terminal connected to the console port. This section discusses important cabling information to consider before connecting the router to a console terminal.

Depending on the cable and the adapter used, this port appears as a DTE or DCE device at the end of the cable. Only one port can be used at the same time.

The default parameters for the console port are 9600 baud, 8 data bits, no parity, and 1 stop bit. The console port does not support hardware flow control.

### Preparing for Network Connections

When setting up your router, consider distance limitations and potential electromagnetic interference (EMI) as defined by the applicable local and international regulations.

Network connection considerations are provided for several types of network interfaces and are described in the following sections:

**Warning**

**To avoid electric shock, do not connect safety extra-low voltage (SELV) circuits to telephone-network voltage (TNV) circuits. LAN ports contain SELV circuits, and WAN ports contain TNV circuits. Some LAN and WAN ports both use RJ-45 connectors. Statement 1021**

### Ethernet Connections

The IEEE has established Ethernet as standard IEEE 802.3. The Cisco IR8340 router supports 10/100/1000 STP Ethernet connection and 100/1000 SFP connection.

### Serial Connections

Serial connections are provided by the RS232 serial Network Interface Module (NIM) . Before you connect a device to a serial port, you need to know the following:

- Type of device, data terminal equipment (DTE) or data communications equipment (DCE), you are connecting to the synchronous serial interface
- Type of connector, male or female, required to connect to the device
- Signaling standard required by the device



### Serial Connection Cables

The serial ports on the asynchronous/synchronous serial network modules use the following cables. Serial ports can be configured as DTE or DCE, depending on the serial cable used.

**Table 3: Interface Cables for 68-pin Connector**

Interface Type and description	Cisco Product Number
4-port ELA-232 DTE, 10ft, Male DB-25	CAB-HD4-232MT
4-port EIA-232 DCE, 10ft, Female DB-25	CAB-HD4-232FC
4-port EIA-232 DTE, 10ft, Female RJ-45	CAB-QUAD-ASYNC-F
4-port ELA-232 DTE, 10ft, Male RJ-45	CAB-QUAD-ASYNC-M
4-port ELA-232 DTE, 10ft, Male DB-9	CAB-9AS-M

### Serial DTE or DCE Devices

A device that communicates over a synchronous or asynchronous serial interface is either a DCE or DTE device. A DCE device provides a clock signal that paces the communications between the device and the router. A DTE device does not provide a clock signal. DTE devices usually connect to DCE devices. The documentation that accompanied the device should indicate whether it is a DTE or DCE device. (Some devices have a jumper to select either DTE or DCE mode.) The following table lists typical DTE and DCE devices.

Device Type	Gender	Typical Devices
DTE	Male <sup>1</sup>	Terminal PC
DCE	Female <sup>2</sup>	Modem CSU/DSU Multiplexer

<sup>1</sup> If pins protrude from the base of the connector, the connector is male.

<sup>2</sup> If the connector has holes to accept pins, the connector is female.

### Signaling Standards Supported

The serial ports available for the router support the following signaling standards: EIA/TIA-232 (EIA-323). You can order a shielded serial transition cable that has the appropriate connector for the standard you specify. The documentation for the device should indicate the standard used for that device. The router end of the shielded serial transition cable has a VHDCI 68 pin connector. The other end of the serial transition cable is available with a connector appropriate for the standard you specify.

The serial port can be configured as DTE or DCE, depending on the attached cable.

All serial ports configured as DTE require external clocking from a CSU/DSU or other DCE device.

## Distance Limitations

Serial signals can travel a limited distance at any given bit rate; generally, the slower the data rate, the greater the distance. All serial signals are subject to distance limits, beyond which a signal significantly degrades or is completely lost.

The following table lists the recommended maximum speeds and distances for each serial interface type; however, you might get good results at speeds and distances greater than those listed, if you understand the electrical problems that might arise and can compensate for them.

**Table 4: Serial Signal Transmission Speeds and Distances**

Rate (bps)	Distance for EIA/TIA-232	
	Feet	Meters
2400	200	60
4800	100	30
9600	50	15
19200	25	7.6
38400	12	3.7
56000	8.6	2.6
1544000 (T1)	—	—

### Asynchronous/Synchronous Serial Module Baud Rates

The following baud-rate limitations apply to the slow-speed serial interfaces found in the asynchronous/synchronous serial modules:

- Asynchronous interface—Maximum baud rate is 230 kbps.
- Synchronous interface—Maximum baud rate is 256 kbps full duplex.

## Required Tools and Equipment for Installation and Maintenance

You need the following tools and equipment to install and upgrade the router and its components:

- ESD-preventive cord and wrist strap
- Number 2 Phillips screwdriver
- Phillips screwdrivers: small, 3/16-in. (4 to 5 mm) and medium, 1/4-in. (6 to 7 mm)
- Screws that fit your rack

In addition, depending on the type of modules you plan to use, you might need the following equipment to connect a port to an external network:

- Cables for connection to the WAN and LAN ports (dependent on configuration).

Ethernet hub or PC with a network interface card for connection to an Ethernet (LAN) port.

Console terminal (an ASCII terminal or a PC running HyperTerminal or similar terminal emulation software) configured for 9600 baud, 8 data bits, 1 stop bit, no flow control, and no parity.

Data service unit (DSU) or channel service unit/data service unit (CSU/DSU) as appropriate for serial interfaces.

External CSU for any CT1/PRI modules without a built-in CSU.





## CHAPTER 3

# Installing and Connecting the Router

---

This section describes how to install and connect the Cisco IR8340 router.

- [Installing and Connecting the Router, on page 23](#)
- [Safety Warnings, on page 23](#)
- [Before You Begin, on page 26](#)
- [Unpacking the Router, on page 26](#)
- [Installing the Router in a Rack, on page 27](#)
- [Replacing the SD Flash Memory Card, on page 29](#)
- [Connecting the Console Port, on page 30](#)
- [Connecting WAN and LAN Interfaces, on page 31](#)

## Installing and Connecting the Router

This section describes how to install and connect the Cisco IR8340 router.



---

**Caution** For the optimum temperature ranges, do not operate it in an area that less than the minimum of  $-40^{\circ}\text{C}$  and exceeds a maximum recommended ambient temperature of  $60^{\circ}\text{C}$ .

---



---

**Note** To view specifications for the Cisco Catalyst IR8340 Rugged Series Router, see the IR8340 data sheet.

---

## Safety Warnings



---

**Warning** Only trained and qualified personnel should be allowed to install, replace, or service this equipment. Statement 1030

---



---

**Warning** This unit might have more than one power supply connection. All connections must be removed to de-energize the unit. Statement 1028

---



---

**Warning** Hazardous network voltages are present in WAN ports regardless of whether power to the unit is OFF or ON. To avoid electric shock, use caution when working near WAN ports. When detaching cables, detach the end away from the unit first. Statement 1026

---



---

**Warning** Do not use this product near water; for example, near a bath tub, wash bowl, kitchen sink or laundry tub, in a wet basement, or near a swimming pool. Statement 1035

---



---

**Warning** Avoid using a telephone (other than a cordless type) during an electrical storm. There may be a remote risk of electric shock from lightning. Statement 1038

---



---

**Warning** This unit is intended for installation in restricted access areas. A restricted access area can be accessed only through the use of a special tool, lock and key, or other means of security. Statement 1017

---



---

**Warning** Stability hazard. The rack stabilizing mechanism must be in place, or the rack must be bolted to the floor before you slide the unit out for servicing. Failure to stabilize the rack can cause the rack to tip over. Statement 1048

---



---

**Warning** The chassis should be mounted on a rack that is permanently affixed to the building. Statement 1049

---



---

**Warning** Blank faceplates and cover panels serve three important functions: they prevent exposure to hazardous voltages and currents inside the chassis; they contain electromagnetic interference (EMI) that might disrupt other equipment; and they direct the flow of cooling air through the chassis. Do not operate the system unless all cards, faceplates, front covers, and rear covers are in place. Statement 1029

---



---

**Warning** A ground wire must always be a single piece of wire. Never splice two wires together for a ground. Corrosion and weathering can lead to a poor connection at the splice, making the ground ineffective and dangerous. Statement 270

---



**Warning** To reduce the risk of fire, use only No. 26 AWG or larger telecommunication line cord. Statement 1023



**Warning** Use copper conductors only. Statement 1025



**Warning** A readily accessible two-poled disconnect device must be incorporated in the fixed wiring. Statement 1022



**Warning** Invisible laser radiation may be emitted from the end of the unterminated fiber cable or connector. Do not view directly with optical instruments. Viewing the laser output with certain optical instruments (for example, eye loupes, magnifiers, and microscopes) within a distance of 100 mm may pose an eye hazard. Statement 1056



**Warning** To prevent the system from overheating, do not operate it in an area that exceeds the maximum recommended ambient temperature of: 60°C (140°F). Statement 1047



**Warning** Hot surface. Statement 1079



**Caution** Heat sinks applicable to warning statement 1079, can exceed 90° C in a 60° C ambient. Suitable precautions should be taken to avoid burns.



**Warning** This equipment needs to be grounded. Use a green and yellow 12 to 14 AWG ground wire to connect the host to earth ground during normal use. Statement 242

## Statement 191—Voluntary Control Council for Interference (VCCI) Class A Warning for Japan



**Warning** This is a Class A product based on the standard of the VCCI Council. If this equipment is used in a domestic environment, radio interference may occur, in which case, you may be required to take corrective actions.

## ステートメント 191—日本向け VCCI クラス A に関する警告



**警告** この装置は、クラス A 機器です。この装置を住宅環境で使用すると電波妨害を引き起こすことがあります。この場合には使用者が適切な対策を講ずるよう要求されることがあります。

VCCI-A

## Statement 1008—Class 1 Laser Product



**Warning** This product is a Class 1 laser product.

## ステートメント 1008—クラス 1 レーザー製品



**警告** クラス 1 レーザー製品です。

## Before You Begin

Before installing and connecting a Cisco IR8340 router, read the safety warnings and gather the following tools and equipment:

- ESD-preventive cord and wrist strap
- Number 2 Phillips screwdriver
- 0# Phillips screwdriver
- Screws that fit your rack

In addition, depending on the type of modules you plan to use, you might need the following equipment to connect a port to an external network:

- Cables for connection to the WAN and LAN ports (dependent on configuration).
- PC with a network interface card for connection to an Ethernet (LAN) port.

## Unpacking the Router

Do not unpack the router until you are ready to install it. If the final installation site will not be ready for some time, keep the chassis in its shipping container to prevent accidental damage. When you are ready to install the router, proceed with unpacking it.



The router, accessory kit, publications, and any optional equipment you ordered may be shipped in more than one container. When you unpack the containers, check the packing list to ensure that you received all of the items on the list.

## Installing the Router in a Rack

The Cisco IR8340 router can only be mounted in a rack.

**Caution**

To prevent damage to the chassis, never attempt to lift or tilt the chassis by holding it by the plastic panel on the front. Always hold the chassis by the sides of the metal body.

**Note**

Allow at least one rack unit of vertical space above and below the router.

## Rack-Mounting the Chassis

The Cisco IR8340 router can be installed in a 19-inch (48.26-cm) standard rack. It is required that at least one rack unit of vertical space is left empty above and below the router.

You can mount the router by attaching the rack-mount brackets at the cable side of the chassis with the cable side facing forward.

The following figure shows the rack-mount brackets used with the Cisco IR8340 router. The brackets extend one rack unit of vertical space that can be either above or below the router.

*Figure 11: Rack-Mount Brackets for the Cisco IR8340 Router*

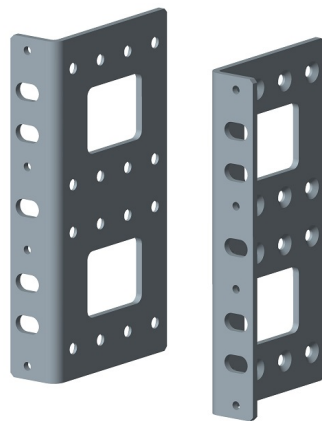

## Attaching Rack-Mount Brackets to Cisco IR8340 Routers

To attach the long side of each bracket to the Cisco IR8340 router, remove the eight Phillips screws from the side panel and use them to attach the bracket to the router. See the following figures.

**Figure 12: Bracket Installation With Vertical Space Below the Router**

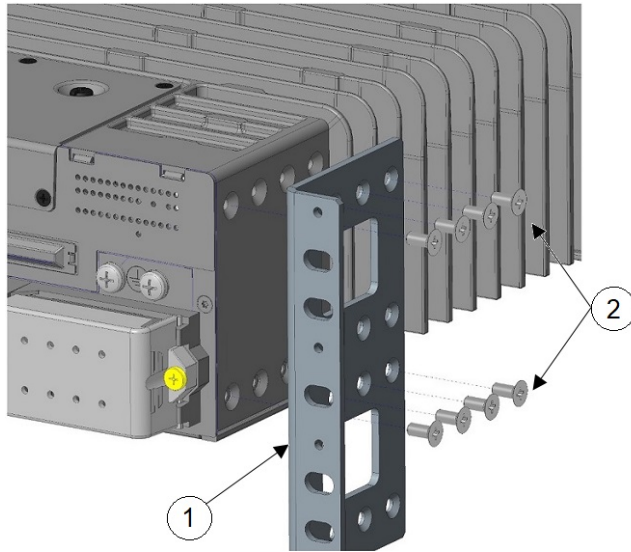

**Figure 13: Bracket Installation With Vertical Space Above the Router**

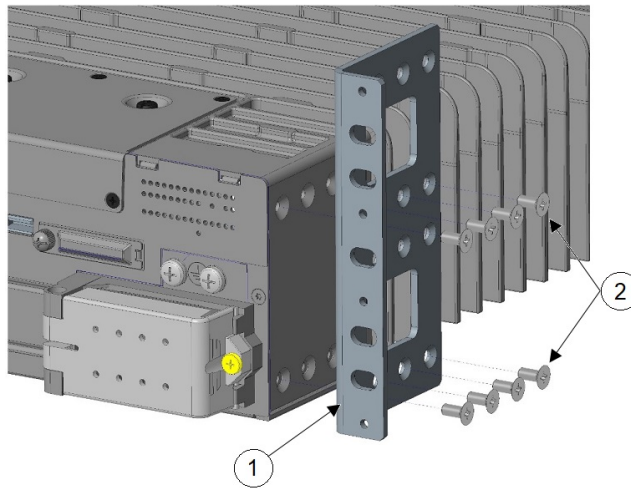

1	Rack-mount bracket	2	Number-8 Phillips flat-head screws (8)
---	--------------------	---	--



**Caution** Do not over-torque the screws. The recommended torque is 16 to 18 in-lbs.

Attach the second bracket to the opposite side of the chassis. Use a number 2 Phillips screwdriver to install the number-8 bracket screws.



**Caution** Your chassis installation must allow unrestricted airflow for chassis cooling.

## Mounting the Router in a Rack

After you attach the rack-mount brackets to the router chassis, use the screws provided with the rack to install the chassis in the rack.



**Note** The screw slots in the brackets are spaced to line up with every *second* pair of screw holes in the rack. When the correct screw holes are used, the small threaded holes in the brackets line up with unused screw holes in the rack. If the small holes do not line up with the rack holes, you must raise or lower the brackets to the next rack hole.



**Caution** A space of one rack unit above and below each IR8340 router is required for sufficient air ventilation.

The following figure shows the screw slots in the rack-mount brackets to use when you mount the router in the rack.

**Figure 14: Mounting Screw Slots**

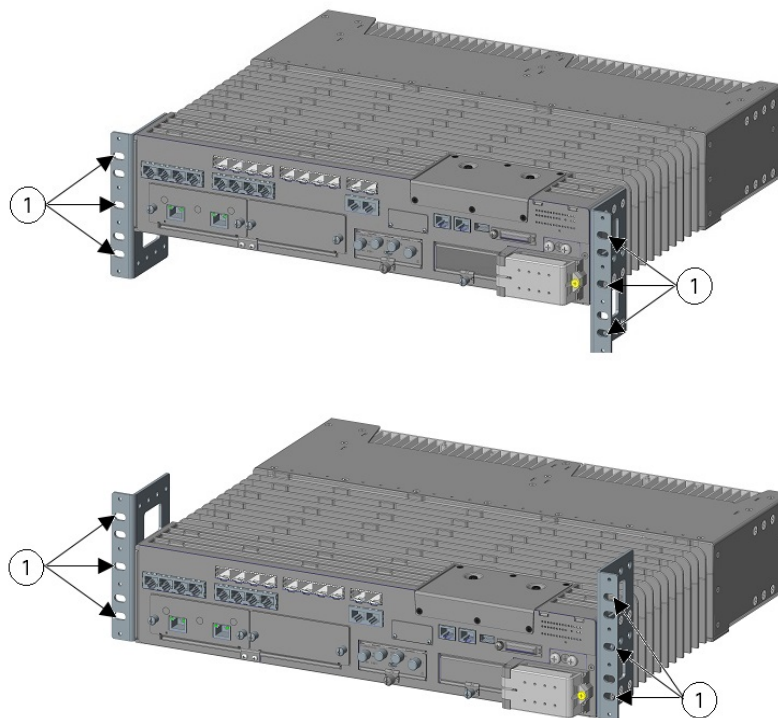

1	Mounting screw slots (6)
---	--------------------------

## Replacing the SD Flash Memory Card

Follow these steps to replace the SD flash memory card:

- 
- Step 1** Locate the flash memory card slot on the cable-side of the router.
- Step 2** Loosen the captive thumb screw. (Be careful not to cross-thread or over-tighten the thumb screw.)
- Step 3** Pull the cover open, and pull the cover tab from the hinge.
- Step 4** Gently push the flash memory card to eject it. Place it in an anti-static bag to protect it from static discharge.
- Step 5** Push the replacement card into the slot, and press it firmly in place. The card is keyed so that you cannot insert it the wrong way.
- Step 6** Place the flash card slot cover tabs into the hinge.
- Step 7** Close the cover, and hand-tighten the screw.
- 

## Connecting the Console Port

To configure the router through the Cisco IOS command-line interface (CLI), you must establish a connection between the router console port and either a terminal or a PC.

### Console Port Connection to a PC

To connect a PC terminal to the console port, use the RJ-45-to-RJ-45 rollover cable, and either the RJ-45-to-DB-25 female DTE adapter or the RJ-45-to-DB-9 female DTE adapter (labeled *TERMINAL*).

The default parameters for the console port are:

- 9600 baud
- 8 data bits
- No parity generated or checked
- 1 stop bit
- No Flow Control

### Console Port Signaling and Cabling with a DB-9 Adapter

This section describes the console port signaling and cabling with a DB-9 adapter. See the following figures.

*Figure 15: RJ-45 Cable to DB-9 Female Adapter*

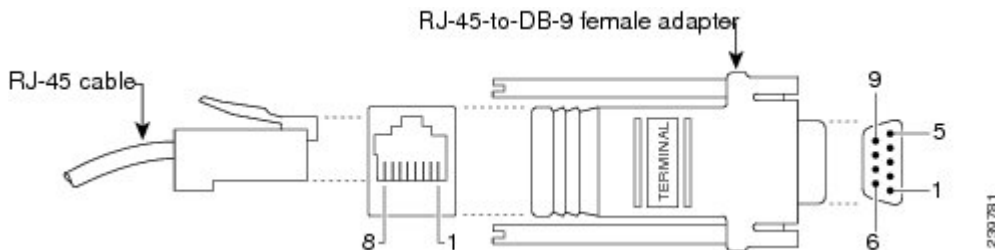
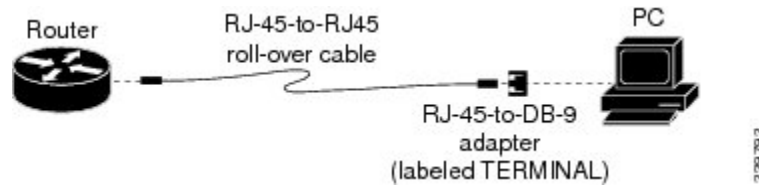

Figure 16: RJ-45 to RJ-45 Rollover Cable



For the pinout descriptions for the DB-9 connections, see [Console Port Adapter Pinouts](#), on page 65.

## Console Port Signaling and Cabling with a DB-25 Adapter

This section describes the console port signaling and cabling with a DB-25 adapter as shown in the following figures.

Figure 17: RJ-45 to DB-25 Adapter (Terminal)

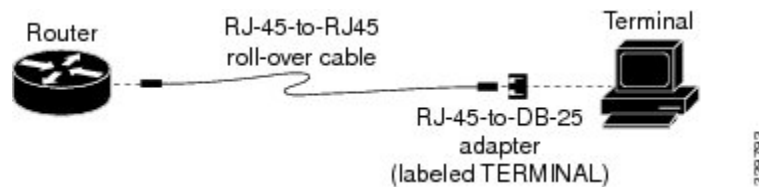
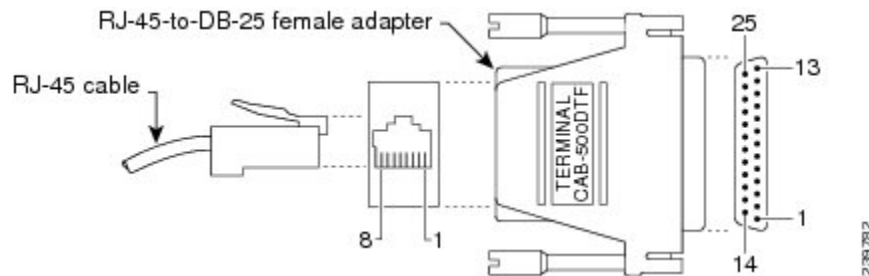

Figure 18: RJ-45 to DB-25 Female Adapter



For the pinout descriptions for the DB-25 connections, see [Console Port Adapter Pinouts](#), on page 65.

## Connecting WAN and LAN Interfaces

This section describes how to connect WAN and LAN interface cables.



**Warning** Do not work on the system or connect or disconnect cables during periods of lightning activity. Statement 1001



**Warning** To avoid electric shock, do not connect safety extra-low voltage (SELV) circuits to telephone-network voltage (TNV) circuits. LAN ports contain SELV circuits, and WAN ports contain TNV circuits. Some LAN and WAN ports both use RJ-45 connectors. Use caution when connecting cables. Statement 1021



---

**Warning** Hazardous network voltages are present in WAN ports regardless of whether power to the unit is OFF or ON. To avoid electric shock, use caution when working near WAN ports. When detaching cables, detach the end away from the unit first. Statement 1026

---

## Connection Procedures and Precautions

To properly connect cables:

- 
- Step 1** Connect each WAN and LAN cable to the appropriate connector on the chassis or on an interface card.
  - Step 2** Position the cables carefully, so that they do not put strain on the connectors.
  - Step 3** Organize cables in bundles so that cables do not intertwine.
  - Step 4** Inspect the cables to make sure that the routing and bend radius is satisfactory. Reposition cables, if necessary.

**Note** Install cable ties in accordance with site requirements.

---



## CHAPTER 4

# Power Supply Installation

This chapter describes how to remove and install a new or replacement power supply. Your router ships with at least one installed power-supply module (AC or DC, depending on your order).

The power-supply modules are field-replaceable units (FRUs) and are hot-swappable when deployed in non-hazardous locations.

- [Power Supply Installation, on page 33](#)
- [Power-Supply Modules, on page 33](#)
- [Power-Supply Module Installation, on page 35](#)
- [Removing the Power Supply Module, on page 44](#)

## Power Supply Installation

This chapter describes how to remove and install a new or replacement power supply. Your router ships with at least one installed power-supply module (AC or DC, depending on your order).

The power-supply modules are field-replaceable units (FRUs) and are hot-swappable when deployed in non-hazardous locations.

## Power-Supply Modules

The following table lists the supported power supply modules. For detailed specifications, see the data sheet.

**Table 5: Power Supply Modules**

Model	Description
PWR-RGD-AC-DC	High-voltage AC or DC, 100-240VAC 50-60Hz/100-250VDC input, 150 watt output
PWR-RGD-LOW-DC	Low-voltage DC, 24-60VDC input, 150 watt output
PWR-RGD-AC-DC-250	High-voltage AC or DC, 100-240VAC 50-60Hz/100-250VDC input, 250 watt output

Figure 19: PWR-RGD-AC-DC Power-Supply Module

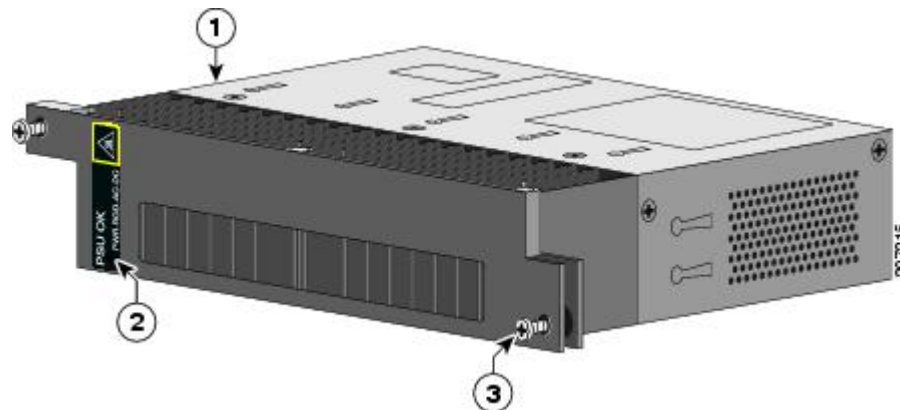

1	Power-supply module	3	Captive screw
2	PSU OK LED		

Figure 20: PWR-RGD-LOW-DC Power-Supply Module

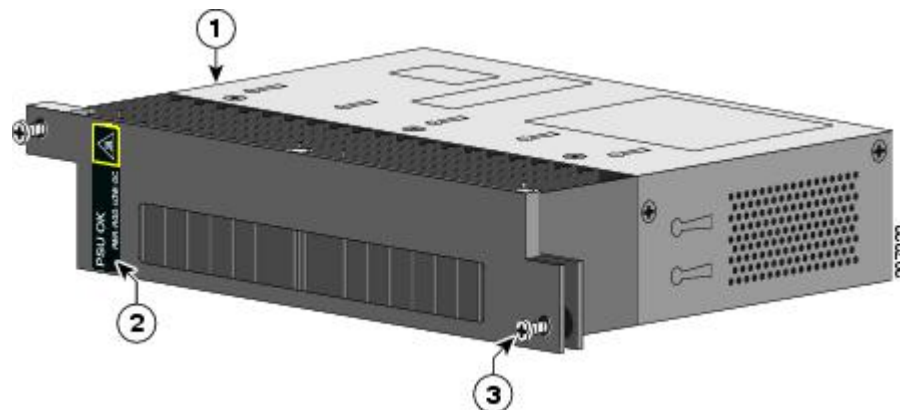

1	Power-supply module	3	Captive screw
2	PSU OK LED		

For a description of the PSU OK LEDs, see [Power-Supply Module LEDs](#), on page 34.

## Power-Supply Module LEDs

The router power-supply module LEDs are labeled PSU1 and PSU2 (on the router) and PSU OK (on the power-supply module). They show whether power-supply modules 1 and 2 are receiving power.

Table 6: Power Supply Module LEDs

Color	System Status
Off	Power-supply module (1 or 2) is not installed.



Color	System Status
Green	Valid input is present, and the output is within the operating range.
Red	Valid input is present, and the output is outside the operating range or is not present.
Blinking red	Power-supply module (1 or 2) is installed but valid input is not present.

# Power-Supply Module Installation

## Installation Guidelines

Observe these guidelines when removing or installing a power-supply module:

A power-supply module that is only partially connected to the router disrupts the system operation.



**Warning** Blank faceplates and cover panels serve three important functions: they prevent exposure to hazardous voltages and currents inside the chassis; they contain electromagnetic interference (EMI) that might disrupt other equipment; and they direct the flow of cooling air through the chassis. Do not operate the system unless all cards, faceplates, front covers, and rear covers are in place. Statement 1029



**Warning** Do not reach into a vacant slot while installing or removing a module. Exposed circuitry is an energy hazard. Statement 206



**Warning** Only trained and qualified personnel should be allowed to install, replace, or service this equipment. Statement 1030



**Warning** Avoid using or servicing any equipment that has outdoor connections during an electrical storm. There may be a risk of electric shock from lightning. Statement 1088

## Installing a Power-Supply Module

This procedure is for installing a power-supply module in the PSU1 or PSU2 slot.



**Warning** The covers are an integral part of the safety design of the product. Do not operate the unit without the covers installed. Statement 1077



---

**Warning** This unit might have more than one power supply connection. All connections must be removed to de-energize the unit. Statement 1028

---



---

**Caution** Equipment installation must comply with local and national electrical codes.

---

## Equipment That You Need

- Torque driver(s) capable of 5 to 35 in-lbs
- Ring, spade, or flanged spade terminal (terminals should be insulated)
  - Ring terminal (such as Tyco part number 2-34158-1 for 16– 14 AWG or 2-34852-1 for 12– 10 AWG wire)
  - Spade terminal (such as Tyco part number 54367-2 for 16– 14 AWG wire)
  - Flanged spade terminal (such as Tyco part number 2-324165-1 for 16– 14 AWG wire or 1-324581-1 for 12– 10 AWG wire)
- Use the 16-14 AWG wire and appropriate terminals for the AC or high-voltage DC power supply
- Use the 12-10 AWG wire and appropriate terminals for the low-voltage DC power supply
- Crimping tool (such as Thomas & Bett part number WT2000, ERG-2001)
- 6-gauge copper ground wire
- 12-AWG wire (minimum) for the low-voltage power-supply module and 16-AWG (minimum) wire for the high-voltage power-supply module
- For power source connections, use wires rated for at least 194°F (90°C).
- UL- and CSA-rated style 1007 or 1569 twisted-pair copper wire
- Wire-stripping tools for stripping 6-, 10-, 12-, 14-, and 16-gauge wires.
- Number-2 Phillips screwdriver
- Flat-blade screwdriver

## Grounding the router

Follow the grounding procedures at your site and observe these warnings:



---

**Warning** This equipment must be grounded. Never defeat the ground conductor or operate the equipment in the absence of a suitably installed ground conductor. Contact the appropriate electrical inspection authority or an electrician if you are uncertain that suitable grounding is available. Statement 1024

---



---

**Warning** When installing or replacing the unit, the ground connection must always be made first and disconnected last. Statement 1046

---



---

**Caution** Follow the grounding procedure instructions, and use an appropriately Listed or certified lug (included with the router) for number-6 AWG wire and 10-32 ground-lug screws.

---



**Note** You can use the grounding lug to attach a wrist strap for ESD protection during servicing.

Follow these steps to install a dual-hole lug on the router. Be sure to follow any grounding requirements at your site.

**Step 1** Use a Phillips screwdriver or a ratcheting torque screwdriver with a Phillips head to remove the ground screws from the cable side of the router. You need the screws in Step 4.

**Step 2** Strip the 6-gauge ground wire to 0.5 inch (12.7 mm)  $\pm$  0.02 inch (0.5 mm). See the following figure. Stripping more than the recommended amount of wire can leave exposed wire from the connector.

**Figure 21: Stripping the Ground Wire**

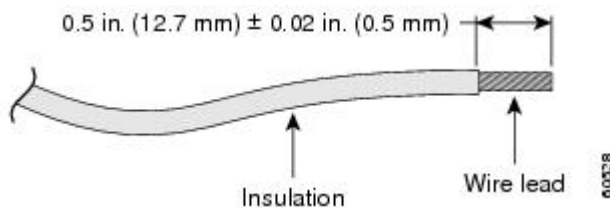

**Step 3** Insert the ground wire into the terminal lug, and crimp the terminal to the wire. (see the following figure).

**Figure 22: Crimping the Terminal Lug**

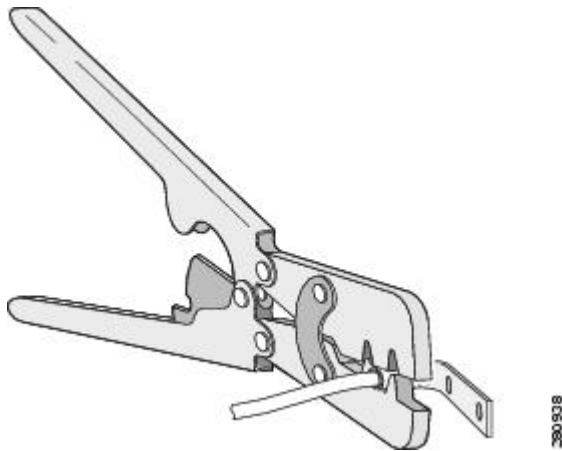

**Step 4** Slide the ground screws from Step 1 through the terminal lug. Insert the ground screws into the opening on the cable side.

## Installing the Power Supply Module in the Router

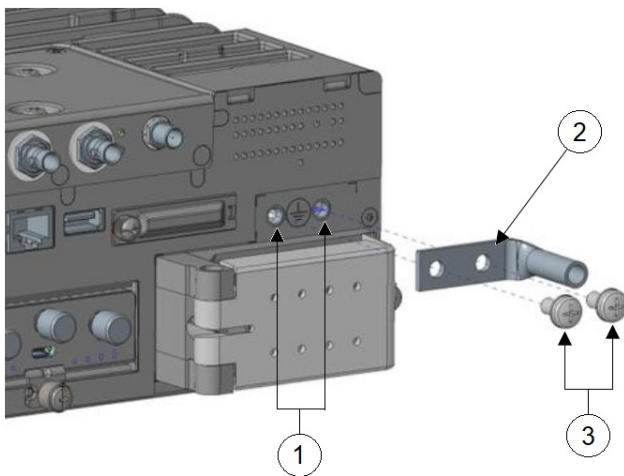

1	Ground lug mounting points	2	Terminal lug
3	M4 screws (2)		

**Step 5** Use a ratcheting torque screwdriver to tighten the ground screws to 11 to 14 in-lbs.

**Step 6** Attach the other end of the ground wire to an appropriate ground.

## Installing the Power Supply Module in the Router

**Step 1** Ensure that the power is off at the AC or DC circuits.

Locate the circuit breakers, turn them OFF, and lock out the circuit.

**Warning** If the power is not off at the AC or DC circuit breaker, do not touch the power-input terminal.

**Step 2** Use a Phillips screwdriver to loosen the two captive screws of the blank power-supply module and gently pull it out.

**Step 3** Insert the power supply module into the slot, and gently push it in. Make sure that the alignment tabs of the module fit into the chassis, as shown in the following figure.

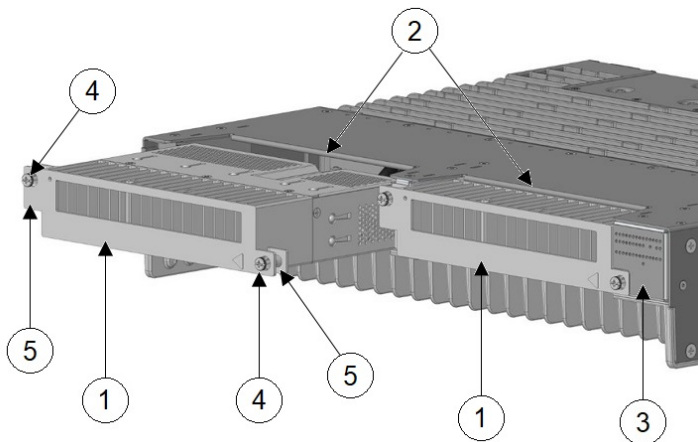

1	Power supply modules	2	Power supply slots
3	LED panel	4	Captive screws
5	Alignment tabs		

- Step 4** After the module is properly inserted, tighten the module plate to the router with the two captive screws. The screws should be torqued to 10 to 12 in-lbs.

## Installing the DC Power Supply in the Router

To remove and install a DC-powered power supply module, follow these steps:

- Step 1** Turn off power at the DC circuits. To ensure that power is removed from the DC circuits, locate the circuit breakers for the DC circuits, switch the circuit breakers to the OFF position, and tape the circuit-breaker switches in the OFF position.
- Step 2** Use a number-2 Phillips screwdriver to remove the plastic safety cover from the power supply terminal blocks.
- Step 3** Use a number-1 Phillips screwdriver to remove the DC-input power wires from the power terminals.  
Use a Phillips screwdriver to loosen the two captive screws at the lower edge that secure the power supply module to the router chassis.
- Step 4** Remove the power supply module from the power slot by pulling on the extraction handle.
- Step 5** Insert the new power supply into the power supply slot, and gently apply pressure while pushing the module into the slot (see the following figure). When correctly inserted, the power supply is flush with the router rear panel.
- Step 6** Use a ratcheting torque screwdriver to torque each screw to 8–10 in-lb (4–6.5 in-lb for 250 W PSU).

## Wiring the Power Source

Before you wire the power source, review these warnings:



**Warning** This product relies on the building's installation for short-circuit (overcurrent) protection. Ensure that the protective device is rated not greater than: AC: 10 A, DC: 15 A Statement 1005



**Warning** A readily accessible two-poled disconnect device must be incorporated in the fixed wiring. Statement 1022



**Warning** Only trained and qualified personnel should be allowed to install or replace this equipment. Statement 1030



**Warning** Hazardous voltage or energy may be present on power terminals. Always replace cover when terminals are not in service. Be sure uninsulated conductors are not accessible when cover is in place. Statement 1086

**Step 1** Ensure that the power is off at the AC or DC circuits.

Locate the circuit breakers, turn them OFF, and lock out the circuit.

**Warning** If the power is not off at the AC or DC circuit breaker, do not touch the power-input terminal.

**Step 2** Use a Phillips screwdriver to loosen the captive screw on the power-input terminal, and open the cover.

*Figure 23: Opening the Power-Input Terminal Cover*

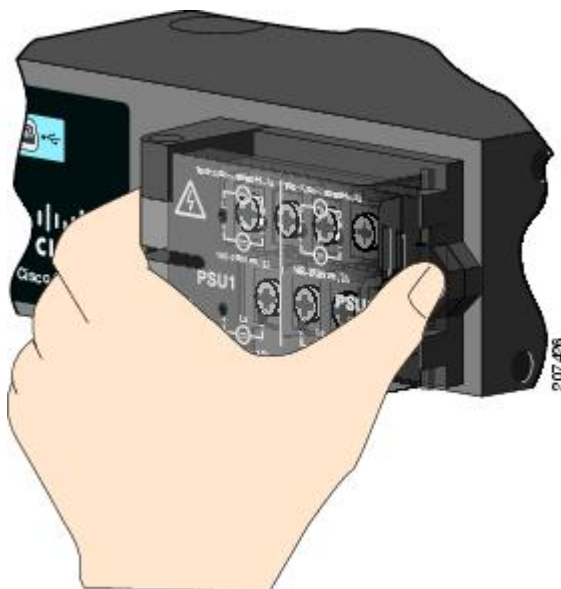

The terminal screws labels are on the power-input terminal cover. See the following figure.

Figure 24: Power-Input Terminal

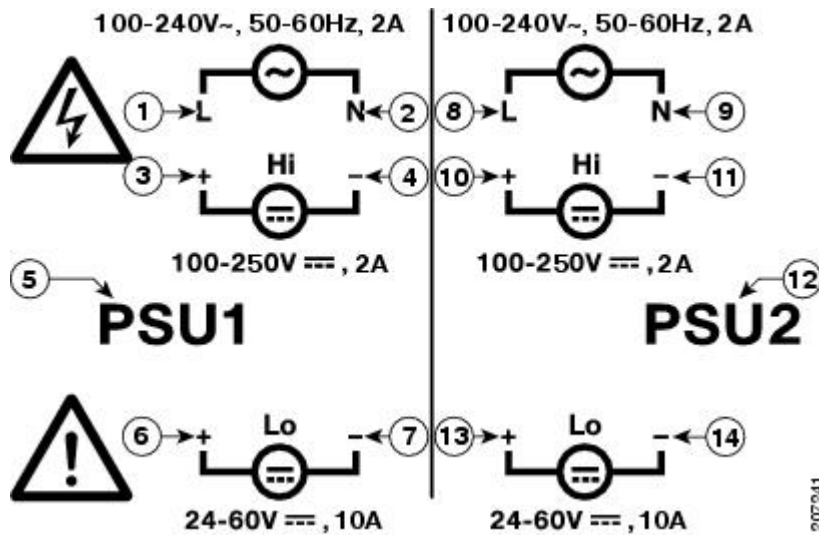

1	Line connection for high-voltage AC (PSU1)	8	Line connection for high-voltage AC (for PSU2)
2	Neutral connection for high-voltage AC (PSU1)	9	Neutral connection for high-voltage AC (PSU2)
3	Positive connection for high-voltage DC (PSU1)	10	Positive connection for high-voltage DC (PSU2)
4	Negative connection for high-voltage DC (PSU1)	11	Negative connection for high-voltage DC (PSU2)
5	PSU1 (power-supply module 1)	12	PSU2 (power-supply module 2)
6	Positive connection for low-voltage DC (PSU1)	13	Positive connection for low-voltage DC (PSU2)
7	Negative connection for low-voltage DC (PSU1)	14	Negative connection for low-voltage DC (PSU2)

**Note** The power-supply module 1 connection is labeled PSU1, and the power-supply module 2 connection is labeled PSU2. Make sure that you connect the wires to the correct terminal screws.

**Step 3** Use twisted-pair copper wire to connect from the power-input terminal to the power source.

**Step 4** Strip each of the two wires to 0.25 inch (6.3 mm)  $\pm$  0.02 inch (0.5 mm).

**Note** Do not strip more than 0.27 inch (6.8 mm) of insulation from the wire. Stripping more than the recommended amount of wire can leave exposed wire from the connector after installation.

Figure 25: Stripping the Input Power Source Wire

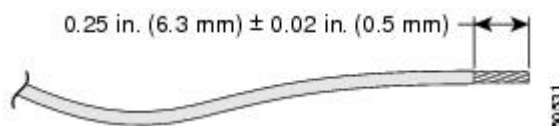

**Step 5** Insert the wire into a spade terminal, and crimp it to the wire.

You can also use a ring or flanged spade terminal as listed in [Equipment That You Need](#), on page 36.

**Figure 26: Crimping the Spade Terminal Lug**

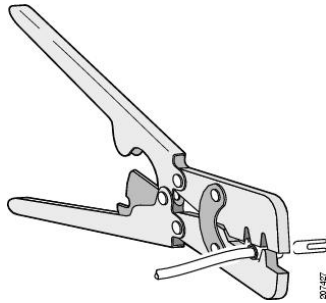

**Step 6** Loosen the terminal screw, and slide the terminal under the screw and washer. See [Figure 28: Connecting the Wires to the Low-Voltage DC Power \(PSU2\)](#), on page 43.

**Note** Use the appropriate terminal screws based on power supply type: high-voltage (AC or DC) or low-voltage (DC).

**Step 7** Make the power connection:

#### AC Power Connection

- Connect the line wire into the terminal screw labeled *L* and the neutral wire into the terminal screw labeled *N* to complete the AC connection.

**Figure 27: Connecting the Wires to the High-Voltage AC Power (PSU1)**

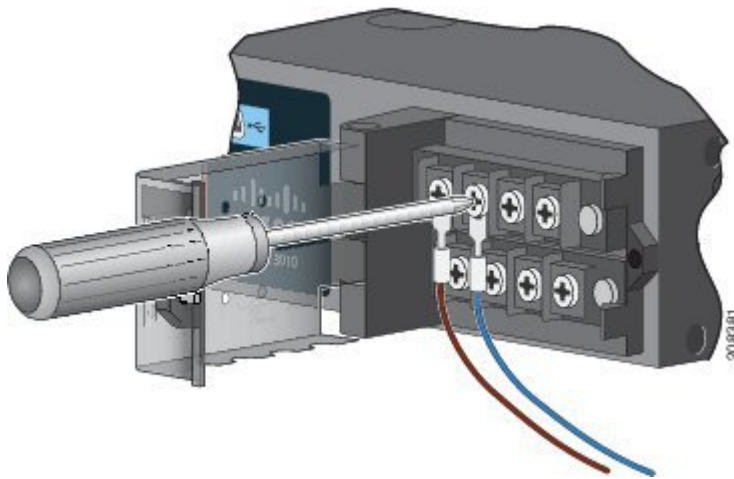

#### DC Power Connection

- Connect the positive wire into the terminal screw labeled “+”, and the negative wire into the terminal screw labeled “-”.

#### Low-voltage DC Power-Supply Module

- Connect the wires to the terminals labeled *Lo*.

#### High-voltage DC Power-Supply Module

- Connect the wires to the terminals labeled *Hi*.



**Note** Ensure that you cannot see any wire lead. Only wire *with insulation* should extend from the terminal screw.

**Figure 28: Connecting the Wires to the Low-Voltage DC Power (PSU2)**

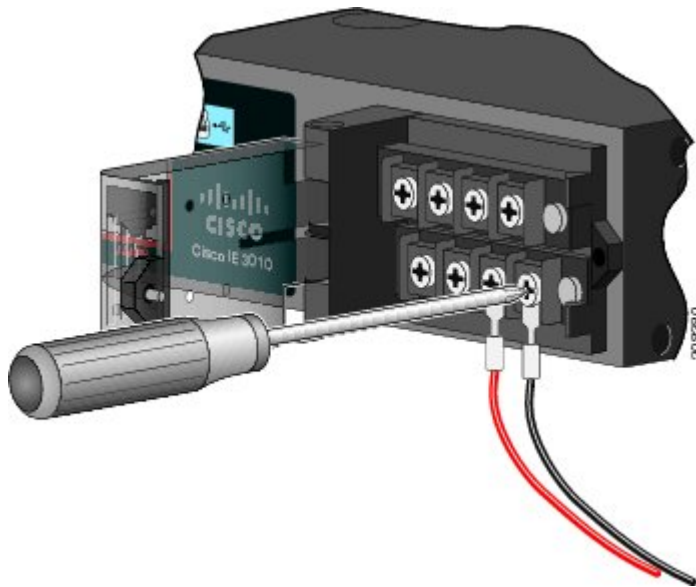

**Step 8** Torque the captive screws (above the wires) to 8.5 in-lb ( $\pm 0.5$  in-lb).

**Step 9** Complete the power connection:

#### AC Power Connection

- Connect the other end of the line wire (the one connected to *L*) to the line terminal on the AC-power source, and connect the other end of the neutral wire (the one connected to *N*) to the neutral terminal on the AC power source.

#### DC Power Connection

- Connect the other end of the positive wire (the one connected to “+”) to the positive terminal on the DC-power source, and connect the other end of the negative wire (the one connected to “-”) to the negative terminal on the DC power source.

**Note** Ensure that you cannot see any wire lead. Only wire *with insulation* should extend from the terminal screw.

If you have two power supplies, repeat steps 1 through 10.

**Step 10** Close the power-input terminal cover.

**Step 11** Use a ratcheting torque screwdriver to torque the screw to 7 in-lb ( $\pm 1$  in-lb).

**Step 12** Turn on the power at the AC or DC circuit.

**Step 13** Verify that the *PSU1* or *PSU2 LED* on the router and *PSU OK* LED on the power-supply module are green.

See the router software guide for information on how to configure the power supply settings.

## Removing the Power Supply Module

The power-supply modules are hot-swappable. By removing the power supply modules, you can power off the router without disconnecting the wiring from the power-input terminal.

---

**Step 1** Ensure that the power is off at the AC or DC circuits.

Locate the circuit breakers, turn them OFF, and lock out the circuit.

**Warning** If the power is not off at the AC or DC circuit breaker, do not touch the power-input terminal.

**Step 2** Verify that the PSU LED and PSU OK LED is blinking red or is off.

**Step 3** Use a Phillips screwdriver to loosen the captive screws that secure the power-supply module to the router.

**Warning** Hot surface. Statement 1079

**Step 4** Remove the power-supply module from the power slot. The power-supply module might be hot. See the following figure.

**Step 5** Install a new power-supply module or a blank cover.

**Caution** To prevent exposure to hazardous voltages and to contain electromagnetic interference (EMI), either a power-supply module or a blank cover must be in each power-supply module slot at all times.

---



## CHAPTER 5

# Installing and Upgrading Modules

This chapter describes how to install and upgrade modules in the Cisco Catalyst IR8340 Rugged Series Router in the following sections:



**Note** Before you perform any module replacement, read [Safety Warnings, on page 45](#) and disconnect power when noted.

- [Safety Warnings, on page 45](#)
- [Installing a Network Interface Module in the IR8340 Router, on page 46](#)
- [Installing Pluggable Modules, on page 47](#)
- [Installing the mSATA SSD, on page 49](#)
- [Installing SFP Modules, on page 50](#)

## Safety Warnings



**Warning** Only trained and qualified personnel should be allowed to install, replace, or service this equipment. Statement 1030



**Warning** Do not work on the system or connect or disconnect cables during periods of lightning activity. Statement 1001



**Warning** Read the installation instructions before connecting the system to the power source. Statement 1004



**Warning** Hazardous network voltages are present in WAN ports regardless of whether power to the unit is OFF or ON. To avoid electric shock, use caution when working near WAN ports. When detaching cables, detach the end away from the unit first. Statement 1026

# Installing a Network Interface Module in the IR8340 Router

To install a Network Interface Module (NIM) in the IR8340 router, follow these steps:

## Before you begin



**Note** Before you install the modules to the router, make sure that the router is fully powered off. Every time you insert or remove a module, the router must be powered off first. The power should be resumed after the module is inserted into or removed from the slot.

**Step 1** Remove the blank faceplate installed at the NIM slot that you intend to use by loosening the two captive screws. Save blank faceplates for future use.

**Step 2** Insert the NIM into one of the router NIM slots, as shown in the following figure.

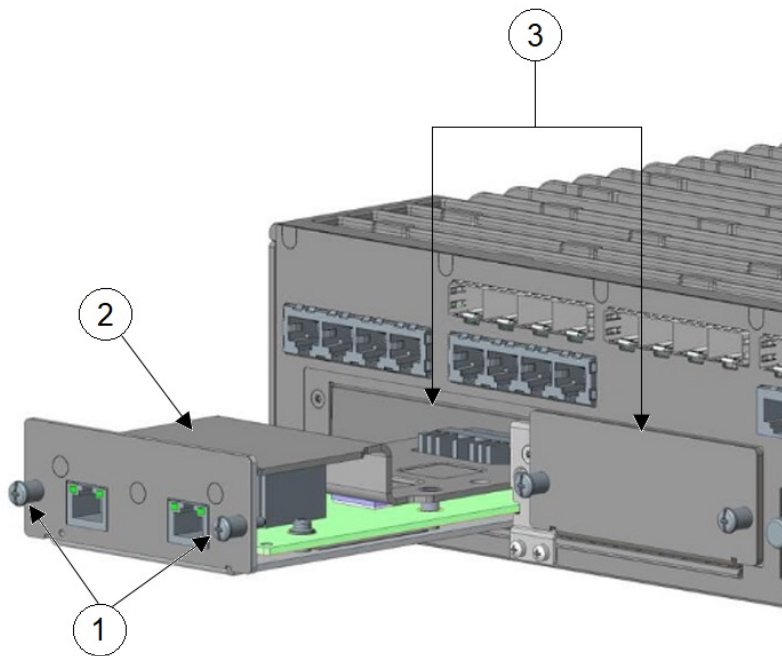

1	Module captive screws (2)	2	NIM module
3	NIM module slots		

**Step 3** Push the module into place until you feel the edge connector seat securely into the connector on the router backplane.

**Step 4** After the module is properly inserted, tighten the module plate to the router with the two captive screws. The screws should be torqued to 5 to 7 in-lbs.

**Step 5** Connect the module to the network and re-enable the power to the slot in the router.

# Installing Pluggable Modules

To install a pluggable interface module (PIM) in the IR8340 router, follow these steps:

## Before you begin



**Note** Before you install the modules to the router, make sure that the router is fully powered off. Every time you insert or remove a module, the router must be powered off first. The power should be resumed after the module is inserted into or removed from the slot.

- Step 1** Remove the blank faceplates installed over the PIM slot that you intend to use by loosening the two captive screws. Save blank faceplates for future use.
- Step 2** Slide the blank plate out of the device.
- Step 3** Prepare the cellular modem module by inserting the micro SIMs applicable for your modems into the device. Remove the screw (1) holding the access plate in place that covers the sim slots. Use a #1 Phillips screwdriver. The access plate is located on the side of the module, as shown in the following figure:

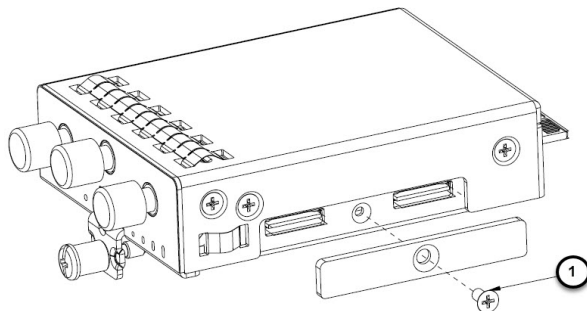

- Step 4** Install your SIMs (1) as shown in the following figure. Make note of the proper slot number and SIM orientation.

Figure 29: SIM Installation

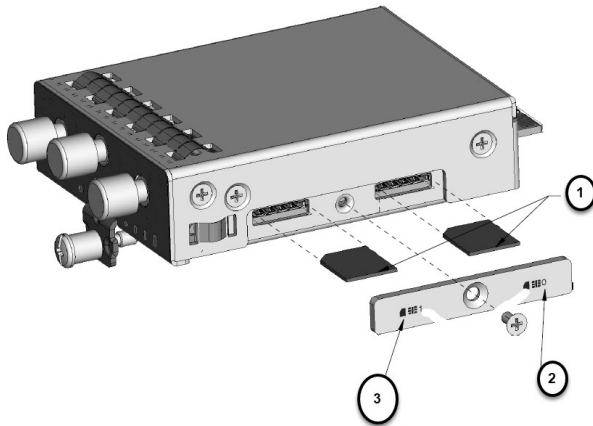

1	Micro SIMs	2	SIM 0 (towards the device)
3	SIM 1 (away from device)		

**Step 5** Push in each SIM until it clicks into place. When the SIMs are installed, re-attach the access plate previously removed with a #1 Phillips screwdriver. Torque to 2.8 to 3.8 in-lbs.

**Note** Make sure that the cover is properly aligned with the screw hole.

**Step 6** If your Pluggable Module has a USB port, make sure that the USB cover is properly installed. Place the USB cover (1) with the plug indentation against the USB port (2). The half circle of the USB cover fits behind the latch lock screw, as shown in the following figure.



**Step 7** Tighten the latch lock screw to a torque of 2.8 to 3.8 in-lbs. The following figure shows a completed USB cover installation.

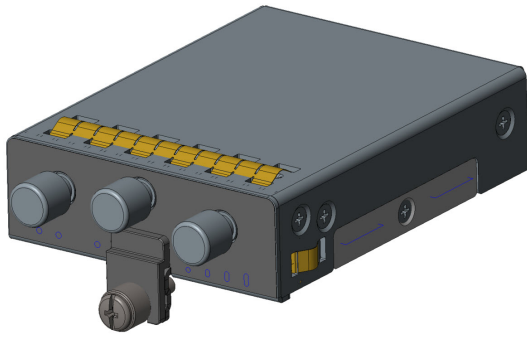

- Step 8** Slide the Pluggable Module into the router. The latch lock screw aligns with the screw hole on the front of the router. Push the Pluggable Module all the way into the device until you feel it seat, and then torque the latch lock screw 5 to 7 in-lbs.

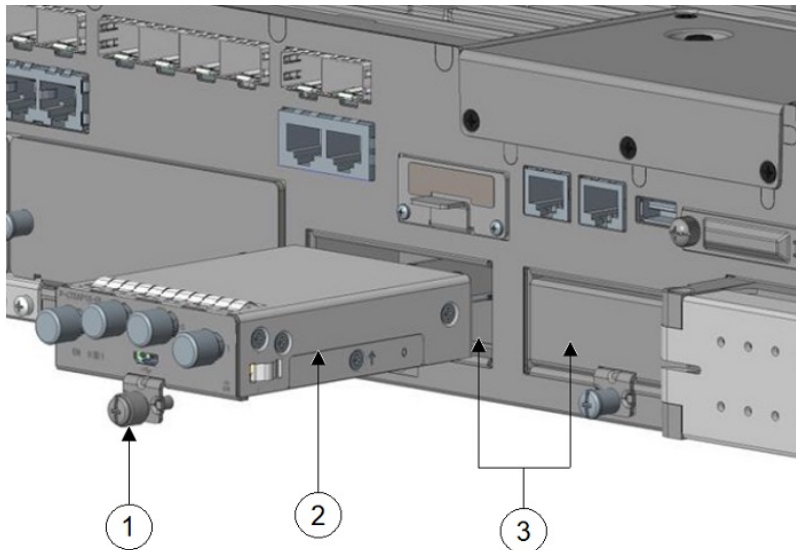

1	Module captive screw	2	PIM module
3	PIM module slots		

- Step 9** Attach your antennas to the ports on the pluggable module. There are different instructions for each antenna type, be sure to consult the antenna documentation for proper orientation and torque to install them.

- Step 10** If no antennas are being installed on a port, make sure the caps are installed on the connector.

## Installing the mSATA SSD

Mini-SATA, or mSATA, is a low-profile interface connector that enables more effective Serial ATA (SATA) integration in small form-factor drives roughly the size of a business card, such as solid state disks (SSDs).



**Note** Make sure that that you are using proper static discharge techniques such as a wrist strap and static mat.



**Caution** Make sure that the device is powered down before performing any removal or installation of a module.

Perform the following steps in order to install the module.

**Step 1** Remove the two captive screws holding the cover of the mSATA slot.

**Step 2** Insert the mSATA SSD module into the slot on the router, as shown in the following figure.

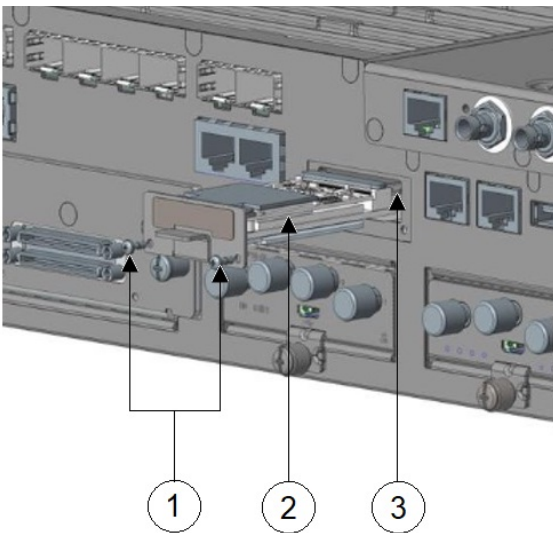

1	Module captive screws (2)	2	mSATA module
3	mSATA module slot		

**Step 3** After the module is properly inserted, tighten the module plate to the router with the two captive screws. The screws should be torqued to 2.3 to 2.9 in-lbs.

## Installing SFP Modules

This section describes how to install optional small-form-factor pluggable (SFP) modules in Cisco IR8340 routers to provide optical Gigabit Ethernet connectivity.

For a list of supported SFP SKUs, see [Table 1: Supported SFP Modules, on page 3](#).

The SFP module installs into a slot on the router's cable side panel. When selected in Cisco IOS software, it is assigned port **gigabitethernet 0/0** or **0/1** for WAN or LAN port. The default is the built-in RJ-45 1000 Base-T connector, which is enabled on this port.





---

**Tip** Use the **show inventory** command at the Cisco IOS prompt to determine whether you are using an SFP certified by Cisco.

---

## Laser Safety Guidelines

Optical SFPs use a small laser to generate the fiber-optic signal. Keep the optical transmit and receive ports covered whenever a cable is not connected to the port.

## Installing SFP Modules

To install an SFP module in a Cisco IR8340 router:

---

**Step 1** Slide the SFP into the router connector until it locks into position.

**Tip** If the SFP uses a bale-clasp latch, the handle should be on top of the SFP module.

**Caution** Do not remove the optical port plugs from the SFP until you are ready to connect cabling.

**Step 2** Connect the network cable to the SFP module.

---

## Removing SFP Modules

To remove an SFP from a Cisco IR8340 router:

---

**Step 1** Disconnect all cables from the SFP.

**Caution** The latching mechanism used on many SFPs locks the SFP into place when cables are connected. Do not pull on the cabling in an attempt to remove the SFP.

**Step 2** Disconnect the SFP latch (see the following figure).

**Note** SFP modules use various latch designs to secure the module in the SFP port. Latch designs are not linked to SFP model or technology type. For information on the SFP technology type and model, see the label on the side of the SFP.

Figure 30: Disconnecting SFP Latch Mechanisms

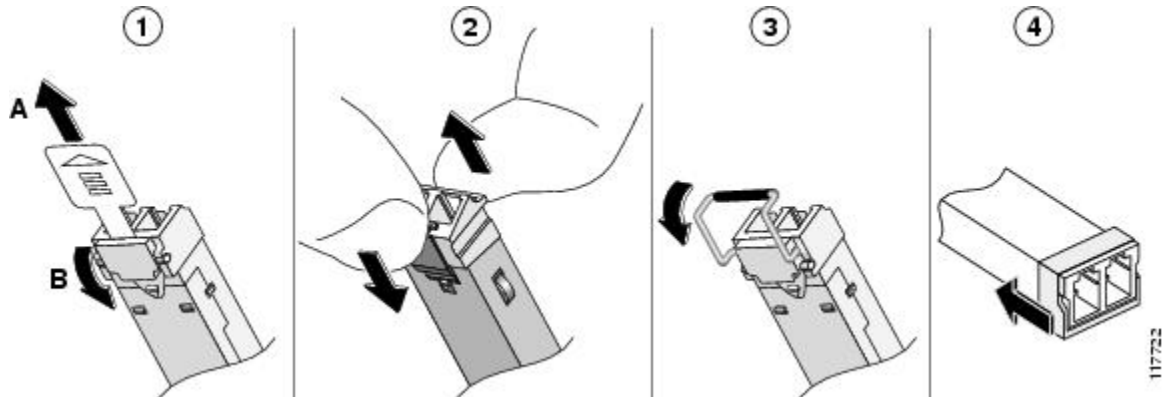

1	Sliding latch	3	Bale-clasp latch
2	Swing and slide latch	4	Plastic collar latch

**Tip** Use a pen, screwdriver, or other small straight tool to gently release a bale-clasp handle if you cannot reach it with your fingers.

**Step 3** Grasp the SFP on both sides and remove it from the router.

---



## CHAPTER 6

# Antenna Selection and Installation

This chapter contains information about installing antennas with the IR8340 router using cellular modules.

- [Antenna Selection and Installation](#), on page 53
- [Antenna Installation Best Practices](#), on page 53
- [Supported Antennas for the IR8340](#), on page 55
- [Supported RF Cables for the IR8340](#), on page 57

## Antenna Selection and Installation



**Note** Before you install the Cisco IR8340 router in a rack, install the antennas on the Pluggable Modules first. It is difficult to install the antennas after the router is mounted.

The P-LTE-xx or P-LTEA-xx cellular modules have three SMA(f) connectors on the pluggable module. Two connectors, Main and Div (Diversity), are used to connect to the 4G/LTE modem. The third connector is used for GPS. The Diversity port is also referred to as an Aux connector.

The P-LTEAP18-GL module has four SMA(f) connectors. Two connectors are Primary (Main) supporting Uplink and Downlink, and two connectors are secondary supporting downlink MIMO.

The P-5GS6-GL module has five SMA(f) connectors, of which four support 4G LTE / 5G FR1 and one supports GPS.

## Antenna Installation Best Practices

The optimal site location for antennas for 4G enabled routers and cellular modules plays a significant role in determining overall cellular link performance. Routers located at the farthest coverage points might have 10 to 50 percent of the bandwidth available compared to routers located closer to the cellular base station tower, away from obstructions, and with an unobstructed view of the cellular tower.

Because antennas transmit and receive radio signals over the air, the signal propagation and antenna performance may be adversely affected by the surrounding environment, including physical obstructions. Radio frequency (RF) interference may also occur between wireless systems located close to each other, especially if the antennas of these systems are located close to each other. Interference may also occur when the antenna is in close proximity to cable clutter or other sources of radio interference.

Follow these guidelines to ensure the best possible performance:

- When you use cellular antennas such as 4G/LTE, 4G/LTEA (LTE Advanced), and 5G NR FR1 with a modular router and a pluggable module, try to mount the antenna a certain distance away from the router. For example, in indoor deployments, an appropriate extension cable and antenna stand can be utilized. For outdoor installations, choose a suitable outdoor antenna, and mount it away from obstructions that ideally have a direct view of the cellular tower. The antenna performance, and therefore that of the router, will not be optimal if mounted directly on a pluggable module. Primary reasons for possible degradation of performance include:
  - Obstruction of the router antenna view of the cellular base station tower by Ethernet cables, power cables, USB cables, and walls.
  - Possible coupling of digital noise from inside the router to the antenna when unshielded Ethernet cables are used.
- Keep antennas away from electrical and signal cable clutter. Metal conductors inside cables may block antenna view of the base station. Additionally, unshielded (and even shielded cables in some cases) may radiate signals that interfere with RF signal reception.
- It is recommended that all cellular antennas for the IR8340 are oriented vertically to ensure polarization match. While polarization of the signal may change as it is reflected from obstructions, when the view is unobstructed - vertical polarization is optimal.



---

**Note** When cellular FDD Band 5 is deployed with 4G/LTE or 4G/LTEA C/A, such as with P-LTEA-EA pluggable modules on certain carriers, ensure that both Main and Aux cellular antennas are physically separated from the IR8340 chassis by a minimum of 5 feet (1.5 meters). This note only affects P-LTE-xx receiver operation in Band 5 in a narrow 875 MHz frequency range. No significant effect on the P-LTE-xx cellular Band 5 receiver has been measured when antennas are separated from the chassis by more than 5 feet (1.5 meters). This note does not apply when the receive signal does not overlap 875 MHz, such as when operating on other bands, or other frequencies within FDD Band 5.

---

- For optimal MIMO performance, set the cellular Main and Aux antennas apart by at least 20 inches (50 cm). At the lowest LTE frequency of 617 MHz, 20 inches represents 1 wavelength. Spacing of half (or 0.5) wavelength or 10 inch (25 cm) results in good MIMO performance.
- Spacing Main and Aux LTE antennas less than 10 inches may result in significantly reduced MIMO performance.
- Spacing antennas too close to each other, for example, 3 inches, results in antennas significantly detuning from their original designed performance due to antenna coupling.
- Wherever possible, mount the IR8340 router with the pluggable LTE module and antenna where the cellular base station or tower are within sight and without physical obstructions. Barriers along the line of sight between the router and the local base station will degrade the wireless radio signals. Install the IR8340, pluggable modules and antennas above floor level in office environments or near the ceiling for better performance because most obstructions tend to be near the floor level.

- The density of the materials used in a building's construction determines the number of walls the signal must pass through while still maintaining adequate coverage. Consider the following before choosing the location for installing the antenna:
  - Paper and vinyl walls have very little effect on signal penetration.
  - Solid and precast concrete walls limit signal penetration to one or two walls without degradation of coverage.
  - Concrete and wood block walls limit signal penetration to three or four walls.
  - A signal can penetrate five or six walls constructed of drywall or wood.
  - A thick metal wall or wire-mesh stucco wall causes signals to reflect back and causes poor penetration.
- Avoid mounting the antenna next to a column or vertical support that could create a shadow zone and reduce the coverage area.
- Keep the antenna away from reflective metal objects such as heating and air-conditioning ducts, large ceiling trusses, building superstructures, and major power cabling runs. If necessary, use an extension cable to relocate the antenna away from these obstructions.

## Supported Antennas for the IR8340

All the supported antennas are listed by functional groups.

### Cellular Antennas

Part Number/ Description	RF Connectors	Antenna Frequency Band Support and Gain
<a href="#">Cisco 4G (LTE) / 5G (FR1) Omnidirectional Outdoor Antenna (ANT-5G-OMNI-OUT-N)</a> Outdoor Omnidirectional Antenna.	N(f)	2.5 dBi, 617-960 MHz 4.0 dBi, 1450-4200 MHz 4.3 dBi, 4400-7125 MHz
<a href="#">Cisco Multiband Panel Outdoor 4G MIMO Antenna (ANT-4G-PNL-OUT-N)</a> Multiband Panel Outdoor 4G MIMO dual-port antenna designed to cover cellular 4G bands.	Dual type N female direct connector	698-960 MHz 8.0-10.0 dBi 1710-2170 MHz 6.0-8.5 dBi 2200-2400 MHz 6.5-9.5 dBi 2500-2700 MHz 8.5-9.5 dBi  Antenna is not designed to operate in 1448-1511 MHz Japan band. Does not have high gain.

Part Number/ Description	RF Connectors	Antenna Frequency Band Support and Gain
<p>Cisco 4G (LTE) / 5G (FR1) / GNSS Integrated Indoor and Outdoor Antenna (ANT-5-5G4G1-O)</p> <p>Integrated indoor and outdoor Antenna with five ports; four ports for 4G (LTE) / 5G (FR1) and one port for GNSS.</p>	<p>4 x 4G/5G FR1, SMA(m)</p> <p>1 x GNSS, SMA(m)</p>	<p>2.0 dBi, 617-960 MHz</p> <p>5.0 dBi, 1710-2170 MHz</p> <p>5.6 dBi, 2300-2700 MHz</p> <p>6.6 dBi, 3400 - 3800 MHz</p> <p>6.0 dBi, 4900 - 5925 MHz</p> <p>One port with GNSS element.</p>
<p><a href="#">Cisco Cellular and GPS 3-in-1 Vehicle Mount and Fixed Infrastructure Antenna (ANT-3-4G2G1-O)</a></p> <p>Fixed Infrastructure Antenna with three ports; two port 2G/3G/4G and one port GPS Vehicle Mount.</p>	<p>2 x 4G/LTE, TNC(m)</p> <p>1 x GPS SMA(m)</p>	<p>4G/LTE 698-960, 1448-1511, 1710-2400, 2500-2700 MHz</p> <p>2.6 dBi typical, 3.8 dBi max 698-960 MHz</p> <p>3.8 dBi typical, 4.3 dBi max 1448-1511 MHz</p> <p>4.6 dBi typical, 5.5 dBi max 1710-2700 MHz</p>
<p><a href="#">Cisco Dual LTE-Single GPS Multi-band Antenna (4G-LTE-ANTM-O-3-B)</a></p> <p>Integrated indoor and outdoor Antenna with three ports; two ports for 2G, 3G, 4G/LTE and one port for GPS.</p>	<p>2 x 4G/LTE, SMA(m)</p> <p>1 x GPS SMA(m)</p>	<p>4G/LTE 698-960, 1710-2700 MHz</p> <p>2.5 dBi typical 698-960 MHz</p> <p>2.5 dBi typical 1710-2700 MHz</p>
<p><a href="#">Cisco Cellular 2-in-1 Vehicle Mount and Fixed Infrastructure Antenna (ANT-2-4G2-O)</a></p> <p>Two port 2G/3G/4G antenna with two elements.</p> <p>This dual port LTE antenna does not have an active GPS antenna (compared to ANT-3-4G2G1-O which does), and is useful for cases when there is no GPS required, or when GPS is connected to a completely separate GPS antenna.</p>	<p>2 x 4G/LTE, TNC(m)</p>	<p>4G/LTE: 698-960,1448-1511,1710-2400,2500-2700 MHz</p> <p>2.6 dBi typical, 3.8 dBi max 698-960 MHz</p> <p>3.8 dBi typical, 4.3 dBi max 1448-1511 MHz</p> <p>4.6 dBi typical, 5.5 dBi max 1710-2700 MHz</p> <p>No GPS element and no WiFi.</p>
<p><a href="#">Cisco Outdoor Omnidirectional Antenna for 2G/3G/4G Cellular (ANT-4G-OMNI-OUT-N)</a></p> <p>Outdoor Omnidirectional Antenna for 2G/3G/4G Cellular antenna is designed to cover domestic LTE700/Cellular/PCS/AWS/MDS, WiMAX 2300/2500, and GSM900/GSM1800/UMTS/LTE2600 bands.</p>	<p>N(f)</p>	<p>1.5 dBi 698-960 MHz</p> <p>2 dBi 1448-1511 MHz</p> <p>3.5 dBi 1710-2700 MHz</p>

## GPS Antennas

Part Number / Description	RF Connectors	Antenna Frequency Band Support and Gain
<p><a href="#">Cisco GPS Antenna (ANT-GPS-OUT-TNC)</a></p> <p>Active GPS antenna, integrated 15' LMR-100 cable with RA-TNC(m).</p> <p>The ANT-GPS-OUT-TNC integrated GPS RF front end is designed to reject collocated RF interference.</p>	Right-angle TNC(m)	Active GPS antenna, 4.0 dBi min at Zenith, 1575.42 MHz, plus 25 dB amplifier gain
<p><a href="#">Cisco Indoor/Outdoor Active GPS Antenna (GPS-ACT-ANTM-SMA)</a></p> <p>Active GPS antenna that can be physically connected to the Cisco Integrated Services Routers (ISRs) and Cisco Enhanced High-Speed WAN Interface Cards (EHWICs) to receive GPS broadcasts from satellites.</p> <p>GPS-ACT-ANTM-SMA has GPS filters, but all the filters are after the LNA. Therefore, antenna may not be suitable for co-location with strong RF transmitters.</p>	SMA(m)	Active GPS antenna, 4 dBi @Zenith, 1575.42 MHz, plus 27 dB amplifier gain
<p><a href="#">Cisco Dual LTE-Single GPS Multi-band Antenna (4G-LTE-ANTM-O-3-B)</a></p> <p>Integrated indoor and outdoor Antenna with three ports; two ports for 2G, 3G, 4G/LTE and one port for GPS.</p> <p>The 4G-LTE-ANTM-O-3-B integrated GPS RF front end is designed to reject collocated RF interference.</p>	2 x 4G/LTE, SMA(m) 1 x GPS SMA(m)	2.5 dBi typical 698-960 MHz 2.5 dBi typical 1710-2700 MHz One port with GPS element.

## Supported RF Cables for the IR8340

The following tables provide information for the cables supported by the IR8340:

**Table 7: SMA(m) to SMA(f) and SMA(m) to N(m) RF cables**

Antenna Cable Type	Description	RF Loss
CAB-L195-10-SM-SF	LMR195, 10ft SMA(m) to SMA(f)	1.2 dB @ 1.0 GHz 2.2 dB @ 3.0 GHz 3.0 dB @ 5.0 GHz 3.6 dB @ 7.0 GHz

Antenna Cable Type	Description	RF Loss
CAB-L240-20-SM-SF	LMR240, 20ft SMA(m) to SMA(f)	1.6 dB @ 1.0 GHz 2.9 dB @ 3.0 GHz 3.8 dB @ 5.0 GHz 4.6 dB @ 7.0 GHz
CAB-L240-10-SM-NM	LMR240, 10ft SMA(m) to N(m)	0.9 dB @ 1.0 GHz 1.5 dB @ 3.0 GHz 2.0 dB @ 5.0 GHz 2.4 dB @ 7.0 GHz

Table 8: TNC(m) to SMA(m) RF cables

Antenna Cable Type	Description	RF Loss
CAB-L240-10-SM-TM	SMA(m)-STR to TNC(m)-STR LMR-240, 10ft RF cableType: outdoor DB (direct burial)	0.8 dB @ 0.7 GHz 0.9 dB @ 1.0 GHz 1.2 dB @ 1.7 GHz 1.5 dB @ 2.4 GHz 1.6 dB @ 2.7 GHz
CAB-L240-15-SM-TM	SMA(m)-STR to TNC(m)-STR LMR-240, 15ft RF cableType: outdoor DB (direct burial)	1.1 dB @ 0.7 GHz 1.4 dB @ 1.0 GHz 1.8 dB @ 1.7 GHz 2.2 dB @ 2.4 GHz 2.3 dB @ 2.7 GHz
CAB-L240-20-SM-TM	SMA(m)-STR to TNC(m)-STR LMR-240, 20ft RF cableType: outdoor DB (direct burial)	1.5 dB @ 0.7 GHz 1.8 dB @ 1.0 GHz 2.4 dB @ 1.7 GHz 2.9 dB @ 2.4 GHz 3.1 dB @ 2.7 GHz



Table 9: N(m) to TNC(m) RF cable

Antenna Cable Type	Description	RF Loss
CAB-L400-20-TNC-N	TNC(m)-RA to N(m)-STRLMR-400, 20 foot RF cable Type: outdoor DB (direct burial)	0.8 dB @ 0.7 GHz 1.0 dB @ 1.0 GHz 1.3 dB @ 1.7 GHz 1.6 dB @ 2.4 GHz
CAB-L400-50-TNC-N	TNC(m)-RA to N(m)-STRLMR-400, 50 foot RF cable Type: outdoor DB (direct burial)	1.9 dB @ 0.7 GHz 2.3 dB @ 1.0 GHz 3.1 dB @ 1.7 GHz 3.8 dB @ 2.4 GHz

Table 10: TNC(m) to TNC(f) RF cable

Antenna Cable Type	Description	RF Loss
4G-CAB-LMR400-10	TNC(m)-RA to TNC(f)-STRLMR-400, 10 foot RF cable Type: outdoor DB (direct burial)	0.4 dB @ 0.7 GHz 0.5 dB @ 1.0 GHz 0.7 dB @ 1.7 GHz 0.8 dB @ 2.4 GHz
4G-CAB-ULL-20	TNC(m)-RA to TNC(f)-STRLMR-400, 20 foot RF cable Type: Plenum	0.8 dB @ 0.7 GHz 1.0 dB @ 1.0 GHz 1.3 dB @ 1.7 GHz 1.6 dB @ 2.4 GHz
4G-CAB-LMR240-25	TNC(m)-RA to TNC(f)-STRLMR-240, 25 foot RF cable Type: Plenum	1.9 dB @ 0.7 GHz 2.3 dB @ 1.0 GHz 3.0 dB @ 1.7 GHz 3.6 dB @ 2.4 GHz

Table 11: N(m) to N(m) RF cables

Antenna Cable Type	Description	RF Loss
AIR-CAB002L240-N	N(m)-STR to N(m)-RALMR-240, 2 foot RF cable Type: Indoor Interconnect. Not DB, CMR or CMP (not direct burial or flame rated)	0.2 dB @ 0.7 GHz 0.3 dB @ 1.0 GHz 0.4 dB @ 1.7 GHz 0.5 dB @ 2.4 GHz 0.8 dB @ 5.8 GHz

Antenna Cable Type	Description	RF Loss
AIR-CAB005LL-N	N(m)-STR to N(m)-RALMR-400, 5 foot RF cable Type: outdoor DB (direct burial)	0.2 dB @ 0.7 GHz 0.3 dB @ 1.0 GHz 0.4 dB @ 1.7 GHz 0.5 dB @ 2.4 GHz 0.8 dB @ 5.8 GHz
CAB-L400-5-N-N	N(m)-STR to N(m)-RALMR-400, 5 foot RF cable Type: outdoor DB (direct burial)	0.2 dB @ 0.7 GHz 0.3 dB @ 1.0 GHz 0.4 dB @ 1.7 GHz 0.5 dB @ 2.4 GHz 0.8 dB @ 5.8 GHz
CAB-L400-5-N-NS	N(m)-STR to N(m)-STR LMR-400, 5 foot RF cable Type: outdoor DB (direct burial)	0.2 dB @ 0.7 GHz 0.3 dB @ 1.0 GHz 0.4 dB @ 1.7 GHz 0.5 dB @ 2.4 GHz 0.8 dB @ 5.8 GHz
AIR-CAB010LL-N	N(m)-STR to N(m)-RALMR-400, 10 foot RF cable Type: outdoor DB (direct burial)	0.4 dB @ 0.7 GHz 0.5 dB @ 1.0 GHz 0.7 dB @ 1.7 GHz 0.9 dB @ 2.4 GHz 1.5 dB @ 5.8 GHz
AIR-CAB025HZ-N	N(m)-STR to N(m)-STR LMR-400, 25 foot RF cable Type: outdoor DB (direct burial) with additional resistance to petrochemicals and oils	1.0 dB @ 0.7 GHz 1.2 dB @ 1.0 GHz 1.6 dB @ 1.7 GHz 2.0 dB @ 2.4 GHz 3.1 dB @ 5.8 GHz
CAB-L600-30-N-N	N(m)-STR to N(m)-RALMR-600, 30 foot RF cable Type: outdoor DB (direct burial)	0.8 dB @ 0.7 GHz 0.9 dB @ 1.0 GHz 1.3 dB @ 1.7 GHz 1.6 dB @ 2.4 GHz 2.6 dB @ 5.8 GHz

## Accessories

The following tables provide information for other accessories supported by the IR8340:

**Table 12: Cisco Lightning Arrestors**

Cisco PID	Connectors Type	Arrestor Type and Frequency Range (MHz)
ACC-LA-G-SM-SF	SMA(m) to SMA(f)	DC to 7000 MHz Supports active GNSS antennas, passes DC
CGR-LA-NM-NF	N(m)-STR to N(f)-STR	DC to 6000 MHz GDT type Supports active GNSS antennas, passes DC
CGR-LA-NF-NF	N(f)-STR to N(f)-STR	DC to 6000 MHz GDT type Supports active GNSS antennas, passes DC
ACC-LA-G-TM-TF	TNC(f)-STR to TNC(m)-STR	DC to 6000 MHz GDT type Supports active GNSS antennas, passes DC
ACC-LA-G-TF-TF	TNC(f)-STR to TNC(f)-STR	DC to 6000 MHz GDT type Supports active GNSS antennas, passes DC

**Table 13: Cisco Coaxial Adapters**

Cisco PID	Connectors Type
AIR-ACC370-NF-NF	N(f)-STR to N(f)-STR
LTE-ADPT-SM-TF	SMA(m)-STR to TNC(f)-STR





## CHAPTER 7

# Cable and Connectors

- [Connector Specifications](#), on page 63
- [10/100/1000 Ports](#), on page 63
- [Cables and Adapters](#) , on page 65

## Connector Specifications

### 10/100/1000 Ports

The 10/100/1000 Ethernet ports on the router use RJ-45 connectors. The following figure shows the pinouts.

*Figure 31: 10/100/1000 Port Pinouts*

Pin	Label	1 2 3 4 5 6 7 8
1	TP0+	
2	TP0-	
3	TP1+	
4	TP2+	
5	TP2-	
6	TP1-	
7	TP3+	
8	TP3-	

Connector pins 1, 2, 3, and 6 are used for PoE and POE+. For UPOE, all pins are used.

## SFP Module Connectors

The following figure shows a LC style connector that is used with the SFP Module slots. It is a fiber-optic cable connector.

Figure 32: Fiber-Optic SFP Module LC Connector



**Warning** Invisible laser radiation may be emitted from disconnected fibers or connectors. Do not stare into beams or view directly with optical instruments. Statement 1051

## Console Port

The router has an RJ-45 (RS-232) console port.

The RJ-45 console port uses an 8-pin RJ-45 connector. An RJ-45-to-DB-9 adapter cable is used to connect the console port of the router to a console PC. You need to provide a RJ-45-to-DB-25 female DTE adapter if you want to connect the router console port to a terminal. You can order a kit (part number ACS-DSBUASYN=) containing that adapter.

## Alarm Port

The alarm port uses an RJ-45 connector. The following figure shows the alarm port details. For more information on alarm input and output, see [Alarm Ports, on page 2](#). For information on alarm ratings, see [Alarm Ratings, on page 69](#).

Figure 33: Alarm Port Details

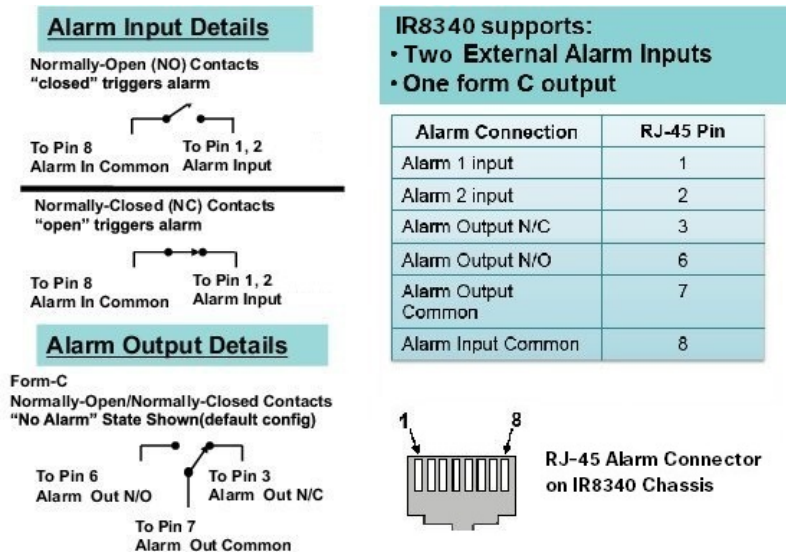

# Cables and Adapters

## SFP Module Cables

Each port must match the wave-length specifications on each end of the cable, and for reliable communications, the cable must not exceed the allowable length.

For more information about SFP/SFP+ modules and cables, see [Transceiver Modules](#).

## Console Port Adapter Pinouts

The console port uses an 8-pin RJ-45 connector. If you did not order a console cable, you need to provide an RJ-45-to-DB-9 adapter cable to connect the router console port to a PC console port. You need to provide an RJ-45-to-DB-25 female DTE adapter if you want to connect the router console port to a terminal. You can order an adapter (part number ACS-DSBUASYN=).

The following table shows the pinout descriptions for the DB-9 connections:

**Table 14: Pinout Descriptions for the DB-9 Connections**

Console Port (DTE)	RJ-45 to RJ-45 Rollover Cable		RJ-45 to DB-9 Terminal Adapter	Console Device	
	Signal	RJ-45 Pin	RJ-45 Pin		DB-9 Pin
RTS		1 <sup>3</sup>	8	8	CTS
DTR		2	7	6	DSR
TxD		3	6	2	RxD
GND		4	5	5	GND
GND		5	4	5	GND
RxD		6	3	3	TxD
DSR		7	2	4	DTR
CTS		8	1	7	RTS

<sup>3</sup> Pin 1 is connected internally to Pin 8.

The following table shows the pinout descriptions for the DB-25 connections:

**Table 15: Pinout Descriptions for the DB-25 Connections**

Console Port (DTE) <sup>4</sup>	RJ-45 to RJ-45 Rollover Cable		RJ-45 to DB-25 Terminal Adapter	Console Device
	Signal	RJ-45 Pin	RJ-45 Pin	

Console Port (DTE) <sup>4</sup>	RJ-45 to RJ-45 Rollover Cable		RJ-45 to DB-25 Terminal Adapter	Console Device
RTS	1 <sup>5</sup>	8	5	CTS
DTR	2	7	6	DSR
TxD	3	6	3	RxD
GND	4	5	7	GND
GND	5	4	7	GND
RxD	6	3	2	TxD
DSR	7	2	20	DTR
CTS	8	1	4	RTS

<sup>4</sup> You can use the same cabling to connect a console to the auxiliary port.

<sup>5</sup> Pin 1 is connected internally to Pin 8.





## CHAPTER 8

# Technical Specifications

- [Router Specifications](#) , on page 67
- [Power-Supply Module Specifications](#), on page 68
- [Alarm Ratings](#), on page 69

## Router Specifications

*Table 16: Cisco Catalyst IR8340 Rugged Series Router Specifications*

<b>Environmental Ranges</b>	
Operating temperature	-40°C to +60°C
Storage temperature	-40 to 185°F (-40 to 85°C)
Relative humidity	5 to 95% (noncondensing)
Operating altitude	Up to 10,000 ft (3048 m)
<b>Physical Specifications</b>	
Weight	Weight with 1 power supply (no modules): 24 lbs (10.9 kg)
	Typical weight fully configured with 2 power supplies 4 modules, timing module: 28 lb (12.7 kg)
Dimensions (H x W x D)	3.5 x 17.25 x 15 in. (88.9 x 438.2 x 381 mm)

Table 17: Cisco IR8340 Router Power Requirements

Power Requirements	
Nominal input voltage	PWR-RGD-AC-DC: 100 to 240 VAC, 50 to 60 Hz, 100 to 250 VDC PWR-RGD-AC-DC-250: 100 to 240 VAC, 50 to 60 Hz, 100 to 250 VDC PWR-RGD-LOW-DC: 24 to 60 VDC

Table 18: Power Consumption

Description	Specification
System power consumption (with no modules and POE)	Typical : 60W, Max : 86W
T1/E1 NIM power consumption	Typical : 6W, Max : 7W
RS232 NIM Power consumption	Typical : 6W, Max : 7W

## Power-Supply Module Specifications

Table 19: Power Supply Module Specifications

Model	Weight	Dimensions (H x W x D)
PWR-RGD-AC-DC	2.55 lb (1.15 kg)	1.58 x 7 x 5 in. (4 x 17.8 x 12.7 cm) (without mounting flanges)
PWR-RGD-LOW-DC	2.5 lb (1.13 kg)	1.58 x 7 x 5 in. (4 x 17.8 x 12.7 cm) (without mounting flanges)
PWR-RGD-LOW-DC-250	3.2 lb (1.45 kg)	1.58 x 7x 6.18 in. (4 x 17.8 x 15.7 cm) (with mounting flanges)

# Alarm Ratings

*Table 20: Alarm Input and Output Ratings*

<b>Alarm Ratings</b>	
Alarm input electrical specification	No external voltage needed to activate alarm inputs. The open circuit voltage between any Alarm input (1 to 2) and Alarm input Common is 5VDC and the loop current is 2 mA max per input.
Alarm output electrical specification	30VDC @ 1A, 48VDC @ 0.5A

