



Selecting and Installing Antennas

These topics are discussed:

- [Overview of the Antennas, on page 1](#)
- [Antenna Installation Best Practices, on page 1](#)
- [Attaching an Antenna to IR8140H, on page 3](#)
- [Supported Antennas for IR8140H, on page 4](#)
- [Supported Antenna Cables and Lightning Arrestors for IR8140H, on page 7](#)

Overview of the Antennas



Note Before you install the Cisco Catalyst IR8140 Heavy Duty Router on a vertical pole or streetlight, install the antennas on the UIMs. It is difficult to install the antennas after the router is installed.

The following section contains information about selecting antennas on the IR8140H router.

The IRMH-LTE or IRMH-LTEA cellular modules have two RF N-type (f) connectors on each UIM, Main and Div (Diversity), which are used to connect to the LTE modem. The Diversity port is also referred to as an Aux connector.

The IRMH-LTEAP18-GL module has four RF N-type (f) connectors. There are two pairs of Main and Diversity connectors, which are used to connect to such modems.

The IRMH-5GS6-GL module has four RF N-type (f) connectors. All four ports support 3G/4G LTE and 5G FR1.

Antenna Installation Best Practices

The optimal site location for antennas in 4G and 5G routers and cellular modules plays a significant role in determining overall cellular link performance. Routers located at the farthest coverage points might have 10 to 50 percent of the bandwidth available compared to routers located closer to the cellular base station tower, away from obstructions, and with an unobstructed view of the cellular tower.

Because antennas transmit and receive radio signals over the air, the signal propagation and antenna performance may be adversely affected by the surrounding environment, including physical obstructions. Radio frequency

(RF) interference may also occur between wireless systems located close to each other, especially if the antennas of these systems are also in close proximity. Interference may also occur when an antenna is in close proximity to cable clutter or other sources of radio interference.

Follow these guidelines to ensure the best possible performance:

- Keep antennas away from electrical and signal cable clutter. Metal conductors inside cables may block the antenna view of the base station. Additionally, unshielded (and even shielded cables in some cases) may radiate signals that interfere with RF signal reception.
- We recommend that all the cellular antennas for the IR8140H are oriented vertically to ensure polarization match. While polarization of the signal may change because it is reflected from obstructions when the view is unobstructed, vertical polarization is optimal.
- For a deployment with both a WPAN module and an LTE module, choose IRMH-LTEA-EA-900 or IRMH-LTE-MNA-900 (with 900-MHz WPAN coexistence filter) as the LTE module, and use recommended antennas and cables. For more information, see [Module Installation Locations](#).

For increased isolation and better WPAN and LTE performance, you can choose 10-ft cables and either ANT-5G-OMNI-OUT-N or any of the available multielement antenna solutions, for example, ANT-4-5G4-O.



Note The antennas should maximize their relative vertical separation.

- For optimal MIMO performance, set the cellular Main and Aux antennas apart by at least 17 inches (43 cm). At the lowest LTE frequency of 700 MHz, 17 inches represents 1 wavelength. Spacing of half (or 0.5) wavelength or 8.5 inch (22.5 cm) results in good MIMO performance.
- Spacing the Main and Aux LTE antennas by less than 8.5 inches may result in significantly reduced MIMO performance.
- Spacing the antennas too close to each other, for example, 3 inches, results in the antennas significantly detuning from their original designed performance because of increased antenna coupling.
- Wherever possible, mount the IR8140H router with the UIM and antenna where the cellular base station or tower are within sight and without physical obstructions. Barriers along the line of sight between the router and the local base station degrade the wireless radio signals. Install the IR8140H, UIMs and antennas above floor level in office environments or near the ceiling for better performance because most obstructions tend to be near the floor level.
- The density of the materials used in a building's construction determines the number of walls the signal must pass through while still maintaining adequate coverage. Consider the following before choosing the location for installing the antenna:
 - Paper and vinyl walls have very little effect on signal penetration.
 - Solid and precast concrete walls limit signal penetration to one or two walls without degradation of coverage.
 - Concrete and wood block walls limit signal penetration to three or four walls.
 - A signal can penetrate five or six walls constructed of drywall or wood.
 - A thick metal wall or wire-mesh stucco wall causes signals to reflect back and causes poor penetration.

- Avoid mounting the antenna next to a column or vertical support that could create a shadow zone and reduce the coverage area.
- Keep the antenna away from reflective metal objects such as heating and air-conditioning ducts, large ceiling trusses, building superstructures, and major power cabling runs. If necessary, use an extension cable to relocate the antenna away from these obstructions.

Important Notes:

This radio transmitter [IC : 2461N-CGMOFDM] has been approved by Innovation, Science and Economic Development Canada to operate with the antenna types listed below, with the maximum permissible gain indicated. Antenna types not included in this list that have a gain greater than the maximum gain indicated for any type listed are strictly prohibited for use with this device.

Le présent émetteur radio [IC: 2461N-CGMOFDM] a été approuvé par Innovation, Sciences et Développement économique Canada pour fonctionner avec les types d'antenne énumérés ci-dessous et ayant un gain admissible maximal. Les types d'antenne non inclus dans cette liste, et dont le gain est supérieur au gain maximal indiqué pour tout type figurant sur la liste, sont strictement interdits pour l'exploitation de l'émetteur.

Attaching an Antenna to IR8140H

This section illustrates how to attach the antenna ANT-5G-MP-OUT-N to IR8140H router.

Recommended tools that you need to install the antenna:

- Torque wrench with the range that can be set to 4 to 4.5 ft-lbs.

Torque wrench setting must be adjusted when using offset socket or strap wrench since the lever arm has increased. Torque wrench setting will be less than the desired setting.

Figure 1: Torque Wrench

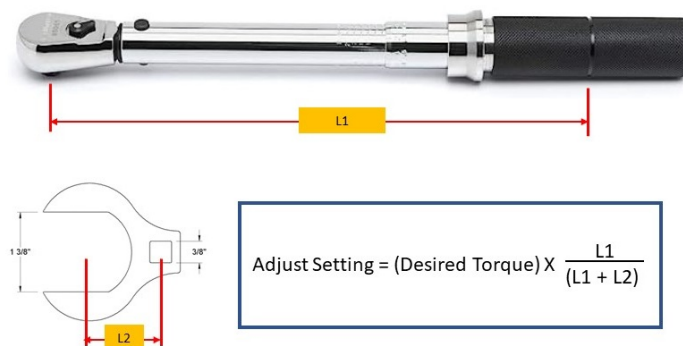

- Tight-clearance offset socket, which is often used with an extension. These sockets turn fasteners and fittings in obstructed areas that a regular socket can't reach.

Figure 2: Tight-Clearance Offset Socket

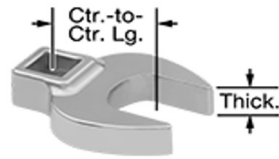

- 3/8" square drive strap wrench, which can be used on the antenna or an offset socket on a torque wrench. The size required is 1 3/8", which should be added to the torque wrench. Pair these wrenches with your square-drive ratchet wrench to create more leverage and torque than you can achieve with standard strap wrenches of the same size. The following figure shows the 3/8" square drive strap wrench.

Figure 3: 3/8" Square Drive Strap Wrench



Be sure to attach the black gasket labeled (1) in the following figure to the antenna before attaching the antenna to the router. Use a torque of 4 to 4.5 ft-lbs to attach the antenna to IR8140H.

Figure 4: Attaching the Gasket to Antenna

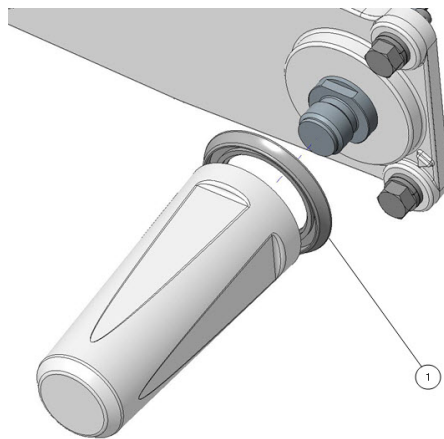

1	Gasket
---	--------

Supported Antennas for IR8140H

See the following tables for information about the supported antennas.

Supported Antennas for Universal Interface Modules

The following table shows the supported antennas for each UIM.

Table 1: Supported Antennas for Universal Interface Modules

UIM	Module PID	Antenna Selection Single Port PID
LTE Advanced (3GPP Category 4)	IRMH-LTE-MNA IRMH-LTE-MNA-900 ¹	2 x LTE (4G/5G) antennas: <ul style="list-style-type: none"> • ANT-5G-OMNI-OUT-N² • ANT-4G-OMNI-OUT-N • ANT-5G-MP-OUT-N
LTE Advanced (3GPP Category 6)	IRMH-LTEA-EA IRMH-LTEA-EA-900 ¹ IRMH-LTEA-LA	2 x LTE (4G/5G) antennas: <ul style="list-style-type: none"> • ANT-5G-OMNI-OUT-N² • ANT-4G-OMNI-OUT-N • ANT-5G-MP-OUT-N
LTE CAT18	IRMH-LTEAP18-GL	4 x LTE (4G/5G) antennas: ³ <ul style="list-style-type: none"> • ANT-5G-OMNI-OUT-N • ANT-5G-MP-OUT-N Or 1x 4-in-1 multielement antenna: ANT-4-5G4-O
4G LTE/5G FR1	IRMH-5GS6-GL	4 x LTE (4G/5G) antennas ³ : <ul style="list-style-type: none"> • ANT-5G-OMNI-OUT-N • ANT-5G-MP-OUT-N Or 1x 4-in-1 multielement antenna: ANT-4-5G4-O

¹ IRMH-LTE-MNA-900 and IRMH-LTEA-EA-900 modules are deployed only when using WPAN and LTE.

² ANT-5G-OMNI-OUT-N needs an extension cable.

³ Use two of each antenna type to maintain proper spatial separation and proper MIMO operation.

Supported Antennas for WPAN Modules

Table 2: Supported Antennas for WPAN Modules

WPAN Module	Module PID	Antenna Selection Single Port PID
IEEE 802.15.4g WPAN (OFDM/FSK)	IRMH-WPAN-NA	ANT-5G-OMNI-OUT-N ⁴
	IRMH-WPAN-BRZ	ANT-WPAN-OD-OUT-N ⁵
		ANT-5G-MP-OUT-N
		ANT-LPWA-DB-O-N-5 ⁶

⁴ ANT-5G-OMNI-OUT-N needs an extension cable.

⁵ For use with WPAN Australia and New Zealand

⁶ ANT-LPWA-DB-O-N-5 needs an extension cable.

Outdoor Antennas

Antenna	PID	Antenna Specifications
Mast-Mounted/Outdoor 4G/5G-FR1	ANT-5G-OMNI-OUT-N	Antenna Type: Dipole Frequency Band: 617-960 MHz 1448-1511 MHz 1695-2690 MHz 3300-4200 MHz 5150-7125 MHz Connector: N-type (f)
Integrated/Multipurpose 4G/5G-FR1	ANT-5G-MP-OUT-N	Antenna Type: Monopole Frequency Band: 617-960 MHz 1710-5925 MHz Connector: N-type (m)
Outdoor/Vertical	ANT-WPAN-OD-OUT-N	Antenna Type: Dipole Frequency Band: 863-928 MHz Connector: N-type (m)

Antenna	PID	Antenna Specifications
Outdoor/Vertical	ANT-LPWA-DB-O-N-5	Antenna Type: Dipole Frequency Band: 863-928 MHz Connector: N-type (f)
4-in-1 (LTE) Outdoor/Vertical	ANT-4-5G4-O	Antenna Type: Multi-Element Frequency Band: 617-960 MHz 1710-5925 MHz Connector: 4xN-type (m) with 10ft low-loss cables

Supported Antenna Cables and Lightning Arrestors for IR8140H

You can choose the N(m) to N(m) RF cables from the following table to use with the antennas that require extension cables. For more information on supported cables, see the [Cisco Industrial Routers and Industrial Wireless Access Points Antenna Guide](#).

Table 3: Supported Antenna Cables for IR8140H

Antenna PID	Extension Cable PID	Cable Description	RF Loss
ANT-5G-OMNI-OUT-N ANT-LPWA-DB-O-N-5	CAB-L400-5-N-NS	N(m)-STR to N(m)-STR LMR-400, 5 foot RF cable Type: outdoor DB (direct burial)	0.2dB @ 0.7 GHz 0.3dB @ 1.0 GHz 0.4dB @ 1.7 GHz 0.5dB @ 2.4 GHz 0.8dB @ 5.8 GHz
	AIR-CAB010LL-N	N(m)-STR to N(m)-RA LMR-400, 10 foot RF cable Type: outdoor DB (direct burial)	0.4dB @ 0.7 GHz 0.5dB @ 1.0 GHz 0.7dB @ 1.7 GHz 0.9dB @ 2.4 GHz 1.5dB @ 5.8 GHz
	CAB-L400-20-N-N	N(m)-STR to N(m)-RA LMR-400, 20 foot RF cable Type: outdoor DB (direct burial)	0.8dB @ 0.7 GHz 1.0dB @ 1.0 GHz 1.3dB @ 1.7 GHz 1.6dB @ 2.4 GHz 2.5dB @ 5.8 GHz

The following table shows the supported lightning arrestor for IR8140H.

Table 4: Supported Lightning Arrestor for IR8140H

Lightning Arrestor PID	Connector Type	Arrestor Type and Frequency Range (MHz)
IOT-LA-NM-NF	N(m)-STR to N(f)-STR	DC to 6000 MHz GDT type