



## BGP NSR Support for MPLS VPNv4 and VPNv6 Inter-AS Option B

Border Gateway Protocol (BGP) nonstop routing (NSR) provides support for NSR and nonstop forwarding (NSF) in the event of a switchover from an active to a standby Route Processor (RP). BGP NSR supports provider-edge-to-customer-edge (PE-CE) connections for IPv4 and IPv6 address families and also for Internal BGP (IBGP) peers at the PE device for IPv4, IPv6, VPN version 4 (VPNv4), and VPN version 6 (VPNv6) address families. The BGP NSR Support for MPLS VPNv4 and VPNv6 Inter-AS Option B feature provides support for NSR at the autonomous system boundary routers (ASBRs) in Multiprotocol Label Switching (MPLS) Inter-Autonomous System (Inter-AS) Option B deployments for both VPNv4 and VPNv6 address families.

This module describes how to enable BGP NSR support at ASBRs in Inter-AS Option B for VPNv4 and VPNv6 address families.

- [Restrictions for BGP NSR Support for MPLS VPNv4 and VPNv6 Inter-AS Option B, on page 1](#)
- [Information About BGP NSR Support for MPLS VPNv4 and VPNv6 Inter-AS Option B, on page 2](#)
- [How to Configure BGP NSR Support for MPLS VPNv4 and VPNv6 Inter-AS Option B, on page 4](#)
- [Configuration Examples for BGP NSR Support for MPLS VPNv4 and VPNv6 Inter-AS Option B, on page 5](#)
- [Additional References for BGP NSR Support for MPLS VPNv4 and VPNv6 Inter-AS Option B, on page 6](#)
- [Feature Information for BGP NSR Support for MPLS VPNv4 and VPNv6 Inter-AS Option B, on page 7](#)

## Restrictions for BGP NSR Support for MPLS VPNv4 and VPNv6 Inter-AS Option B

- If a peer is activated under an address family for which nonstop routing (NSR) is not supported (for example, multicast distribution tree [MDT]), and if the address family topology is tied to the same session as other address family topologies for which NSR is supported (for example, VPN version 4 [VPNv4]), then NSR will not be supported for that peer-established session. NSR cannot be supported for a session if the session establishment involves activating the peer in an address family for which NSR is not supported. As a workaround, you can create a multisession and activate the nonsupported topology as part of a new session.
- NSR can be configured only on a per-neighbor basis.

- There can be some performance and memory impact as a result of enabling BGP NSR support at autonomous system boundary routers (ASBRs) in Inter-AS Option B.

# Information About BGP NSR Support for MPLS VPNv4 and VPNv6 Inter-AS Option B

## Overview of BGP NSR

Border Gateway Protocol (BGP) nonstop routing (NSR) with stateful switchover (SSO) provides a high availability (HA) solution to service providers whose provider edge (PE) routers engage in External BGP (EBGP) peering relationships with customer edge (CE) routers that do not support BGP graceful restart (GR). BGP NSR works with SSO to synchronize BGP state information between the active and standby Route Processors (RPs). SSO minimizes the amount of time for which a network is unavailable to users following a switchover.

BGP NSR with SSO is supported in BGP peer, BGP peer group, and BGP session template configurations.

To configure support for BGP NSR with SSO in BGP peer and BGP peer group configurations, use the **neighbor ha-mode sso** command in address family configuration mode for IPv4 virtual routing and forwarding (VRF) address family BGP peer sessions. To include support for Cisco BGP NSR with SSO in a BGP session template, use the **ha-mode sso** command in session-template configuration mode.

## Inter-Autonomous Systems

BGP autonomous systems (ASs) are used to divide global external networks into individual routing domains where local routing policies are applied. Separate BGP ASs dynamically exchange routing information through External BGP (EBGP) peering sessions. BGP peers within the same AS exchange routing information through Internal BGP (IBGP) peering sessions.

When multiple sites of a VPN are connected to different ASs, Inter-Autonomous System (Inter-AS) deployments are useful for providing VPN services between different ASs. In this scenario, provider edge (PE) routers attached to the VPN cannot maintain IBGP connections with each other or with a common route reflector (RR). EBGP is used to distribute VPN-IPv4/IPv6 addresses. RFC 2547bis presents the following Inter-AS VPN solutions:

- Virtual routing and forwarding (VRF)-to-VRF connections at autonomous system boundary routers (ASBRs)—PEs act as ASBRs of their ASs. The ASBRs are directly connected and manage VPN routes between them through multiple subinterfaces. The ASBRs associate each such subinterface with a VRF and use EBGP to distribute unlabeled IPv4 addresses to each other. This solution is also called "Inter-AS Option A." Inter-AS Option A provides IP-based forwarding between the ASBRs connecting the different ASs; however, it also requires a single BGP session for each VPN connection. Inter-AS Option A is easy to implement, but it has limited scalability.
- EBGP redistribution of labeled VPN-IPv4 routes—Neighboring ASBRs use Multiprotocol External BGP (MP-EBGP) to exchange labeled VPN-IPv4 routes that the ASBRs obtain from PEs in their respective ASs. PE routers use IBGP to redistribute labeled VPN-IPv4 routes either to an ASBR or to an RR of which an ASBR is a client. This solution is also called "Inter-AS Option B." Inter-AS Option B provides Multiprotocol Label Switching (MPLS)-based forwarding between the ASBRs connecting different ASs. Inter-AS Option B provides better scalability than Inter-AS Option A because Option B requires only one BGP session to exchange all VPN prefixes between the ASBRs.

- Multihop EBGP redistribution of labeled VPN-IPv4 routes—PEs exchange labeled VPN-IPv4 routes directly with each other through MP-EBGP without the participation of ASBRs. ASBRs advertise labeled IPv4 routes to PEs in their respective ASs through MP-IBGP. ASBRs neither maintain VPN-IPv4 routes nor advertise VPN-IPv4 routes to each other. This solution is also called "Inter-AS Option C."

## Overview of MPLS VPNv4 and VPNv6 Inter-AS Option B

In the Inter-Autonomous System (Inter-AS) Option B solution, two autonomous system border routers (ASBRs) use Multiprotocol External BGP (MP-EBGP) to exchange labeled VPN-IPv4 routes that they obtain from the provider edge (PE) devices in their respective ASs. Multiprotocol Label Switching (MPLS)-based forwarding is used between the ASBRs. If a failure is encountered at an ASBR, routing and forwarding is impacted in the absence of nonstop routing (NSR) or graceful restart (GR). NSR provides the ability to preserve the routing state to a redundant Route Processor (RP), which can take over the functionality of the active RP in the event of a failover. In conjunction with nonstop forwarding (NSF), the routing and forwarding states can remain unimpacted during a failover.

The figure below illustrates two ASs, AS1 and AS2, each containing customer edge (CE) routers that belong to different VPNs. Each PE tracks which route distinguisher (RD) corresponds to which VPN, thus controlling the traffic that belongs to each VPN.

- Customer edge 1 (CE1) and CE3 belong to VPN 1.
- CE2 and CE4 belong to VPN 2.
- Provider edge 1 (PE1) uses route distinguisher 1 (RD 1) for VPN 1 (VRF 1) and RD 2 for VPN 2 (VRF 2).
- PE2 uses RD 3 for VPN 1 (VRF 1) and RD 4 for VPN 2 (VRF 2).

**Figure 1: Flow of Routes in Inter-AS Option B**

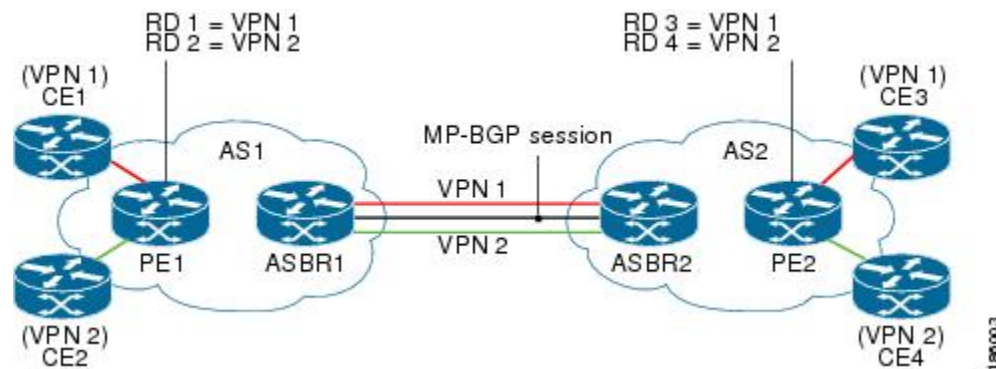

In an Inter-AS Option B scenario like the one in the figure above, the routes are carried across an AS boundary from ASBR1 to ASBR2 over an MP-EBGP session.

In Inter-AS Option B, the routes are advertised as follows:

1. PEs in AS1 advertise labeled VPN-IPv4 routes to either the ASBR of AS1 or the route reflector (RR) of the ASBR through Multiprotocol Internal BGP (MP-IBGP).
2. The ASBR of AS1 advertises labeled VPN-IPv4 routes to the ASBR of AS2 through MP-EBGP.
3. The ASBR of AS2 advertises labeled VPN-IPv4 routes to either the PEs in AS2 or the RR of the PEs through MP-IBGP.

The ASBRs must perform special processing on the labeled VPN-IPv4 routes, which is also called the ASBR extension method.

# How to Configure BGP NSR Support for MPLS VPNv4 and VPNv6 Inter-AS Option B

## Configuring an ASBR to Enable BGP NSR Support in Inter-AS Option B

Border Gateway Protocol (BGP) nonstop routing (NSR) support at autonomous system boundary router (ASBR) in Inter-Autonomous System (Inter-AS) Option B can be configured in the same way that BGP NSR is configured for Multiprotocol Internal BGP (MP-IBGP) peers at the provider edge (PE). The configuration is performed in global router mode, on a per-neighbor basis. The NSR support is applied to all address families under which the neighbor has been activated (provided the neighbor is not activated under a nonsupported address family). If a neighbor is activated under an unsupported address family, that topology must be made to be part of a different session using multisession.

### SUMMARY STEPS

1. **enable**
2. **configure terminal**
3. **router bgp** *autonomous-system-number*
4. **neighbor** *ip-address* **remote-as** *autonomous-system-number*
5. **neighbor** *ip-address* **ha-mode sso**
6. **address-family** {*vpn4* | *vpn6*} [**multicast** | **unicast**]
7. **neighbor** *ip-address* **activate**
8. **end**
9. **show ip bgp vpn4 all sso summary**
10. **show ip bgp vpn4 neighbors** *ip-address*

### DETAILED STEPS

	Command or Action	Purpose
Step 1	<b>enable</b> <b>Example:</b> Device> enable	Enables privileged EXEC mode.  • Enter your password if prompted.
Step 2	<b>configure terminal</b> <b>Example:</b> Device# configure terminal	Enters global configuration mode.
Step 3	<b>router bgp</b> <i>autonomous-system-number</i> <b>Example:</b> Device(config)# router bgp 400	Enters router configuration mode for the specified routing process.
Step 4	<b>neighbor</b> <i>ip-address</i> <b>remote-as</b> <i>autonomous-system-number</i> <b>Example:</b>	Specifies the AS of the neighbor.

	Command or Action	Purpose
	Device(config-router)# neighbor 192.168.1.1 remote-as 4000	
<b>Step 5</b>	<b>neighbor ip-address ha-mode sso</b>  <b>Example:</b> Device(config-router)# neighbor 192.168.1.1 ha-mode sso	Configures a BGP neighbor to support BGP NSR with stateful switchover (SSO).
<b>Step 6</b>	<b>address-family {vpn4   vpn6} [multicast   unicast]</b>  <b>Example:</b> Device(config-router)# address-family vpn4 unicast	Enters address family configuration mode for configuring routing sessions that use standard VPNv4 or VPNv6 address prefixes.
<b>Step 7</b>	<b>neighbor ip-address activate</b>  <b>Example:</b> Device(config-router-af)# neighbor 192.168.1.1 activate	Activates the specified peer.
<b>Step 8</b>	<b>end</b>  <b>Example:</b> Device(config-router-af)# end	Exits address family configuration mode and returns to privileged EXEC mode.
<b>Step 9</b>	<b>show ip bgp vpn4 all sso summary</b>  <b>Example:</b> Device# show ip bgp vpn4 all sso summary	Displays information about BGP peers that support BGP NSR with SSO.
<b>Step 10</b>	<b>show ip bgp vpn4 neighbors ip-address</b>  <b>Example:</b> Device# show ip bgp vpn4 neighbors 192.168.1.1	Displays information about BGP and TCP connections to neighbors.

## Configuration Examples for BGP NSR Support for MPLS VPNv4 and VPNv6 Inter-AS Option B

### Example: Configuring an ASBR to Enable BGP NSR Support in Inter-AS Option B

#### Configuring an ASBR to Be NSR-Capable at the VPNv4 Address Family Level

```
router bgp 200
  neighbor 192.168.1.1 remote-as 200
  neighbor 192.168.1.1 ha-mode sso
  address-family vpn4 unicast
    neighbor 192.168.1.1 activate
```

### Configuring an ASBR to Be NSR-Capable at the VPNv6 Address Family Level

```
router bgp 300
  neighbor 192.168.1.10 remote-as 300
  neighbor 192.168.1.10 ha-mode sso
  address-family vpnv6 multicast
    neighbor 192.168.1.10 activate
```

To verify that an ASBR is NSR-capable, check the **show ip bgp vpnv4 neighbors** command output for the Stateful switchover support enabled field.

```
ASBR# show ip bgp vpnv4 neighbors 192.168.1.10
```

```
BGP neighbor is 192.168.1.10, vrf A, remote AS 200, external link
  BGP version 4, remote router ID 192.168.1.10
  BGP state = Established, up for 00:16:01
  Last read 00:00:04, last write 00:00:35, hold time is 180, keepalive interval is 60 seconds
```

```
Neighbor sessions:
  1 active, is not multiseession capable (disabled)
Neighbor capabilities:
  Route refresh: advertised and received(new)
  Four-octets ASN Capability: advertised and received
  Address family IPv4 Unicast: advertised and received
  Enhanced Refresh Capability: advertised and received
  Multiseession Capability:
  Stateful switchover support enabled: YES for session 1
```

## Additional References for BGP NSR Support for MPLS VPNv4 and VPNv6 Inter-AS Option B

### Related Documents

Related Topic	Document Title
Cisco IOS commands	<a href="#">Cisco IOS Master Command List, All Releases</a>
BGP commands	<a href="#">Cisco IOS IP Routing: BGP Command Reference</a>

**Technical Assistance**

Description	Link
<p>The Cisco Support website provides extensive online resources, including documentation and tools for troubleshooting and resolving technical issues with Cisco products and technologies.</p> <p>To receive security and technical information about your products, you can subscribe to various services, such as the Product Alert Tool (accessed from Field Notices), the Cisco Technical Services Newsletter, and Really Simple Syndication (RSS) Feeds.</p> <p>Access to most tools on the Cisco Support website requires a Cisco.com user ID and password.</p>	<a href="http://www.cisco.com/support">http://www.cisco.com/support</a>

## Feature Information for BGP NSR Support for MPLS VPNv4 and VPNv6 Inter-AS Option B

The following table provides release information about the feature or features described in this module. This table lists only the software release that introduced support for a given feature in a given software release train. Unless noted otherwise, subsequent releases of that software release train also support that feature.

Use Cisco Feature Navigator to find information about platform support and Cisco software image support. To access Cisco Feature Navigator, go to [www.cisco.com/go/cfn](http://www.cisco.com/go/cfn). An account on Cisco.com is not required.

**Table 1: Feature Information for BGP NSR Support for Inter-AS Option B**

Feature Name	Releases	Feature Information
BGP NSR Support for MPLS VPNv4 and VPNv6 Inter-AS Option B	Cisco IOS XE Release 3.10S	<p>The BGP NSR Support for MPLS VPNv4 and VPNv6 Inter-AS Option B feature provides support for nonstop routing (NSR) at the autonomous system boundary routers (ASBR) in Inter-Autonomous System (Inter-AS) Option B deployments for both VPNv4 and VPNv6 address families.</p> <p>No commands were introduced or modified.</p>

