



## Additional References for SONET/SDH Frame Structures

This section provides information about STS-1 and STS-3 frame structures for SONET with concatenated and channelized details, and STM-1 frame with VC details for SDH frame.

For more information on the basic CEM features such as CEM classes and CEM parameters (payload size and dejitter buffer), configuration, and verification, see the [CEM Generic Configuration Guide, Cisco IOS XE 17 \(Cisco ASR 900 Series\)](#).

- [SONET Frame Structure, on page 1](#)
- [SDH Frame Structure, on page 3](#)

## SONET Frame Structure

### STS-1 and STS-3 Frames

A standard STS-1 frame is nine rows by 90 bytes. The first three bytes of each row represent the Section and Line overhead. These overhead bits comprise framing bits and pointers to different parts of the SONET frame.

**Figure 1: STS-1 Frame Structure**

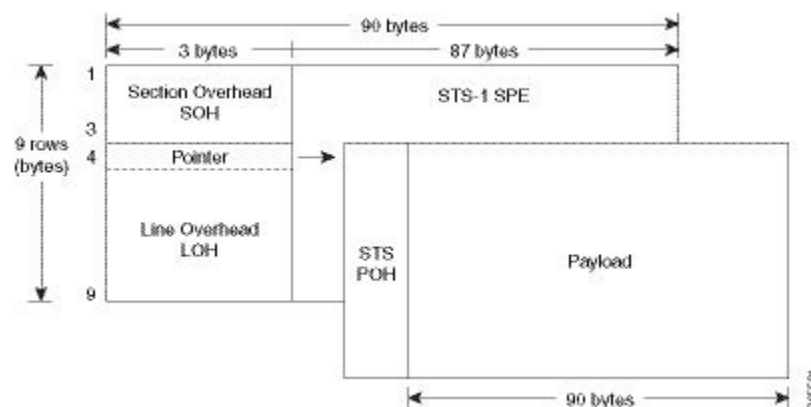

There is one column of bytes in the payload that represents the STS path overhead. This column frequently "floats" throughout the frame. Its location in the frame is determined by a pointer in the Section and Line overhead.

The combination of the Section and Line overhead comprises the transport overhead, and the remainder is the SPE.

Figure 2: STS-1 SONET Overhead

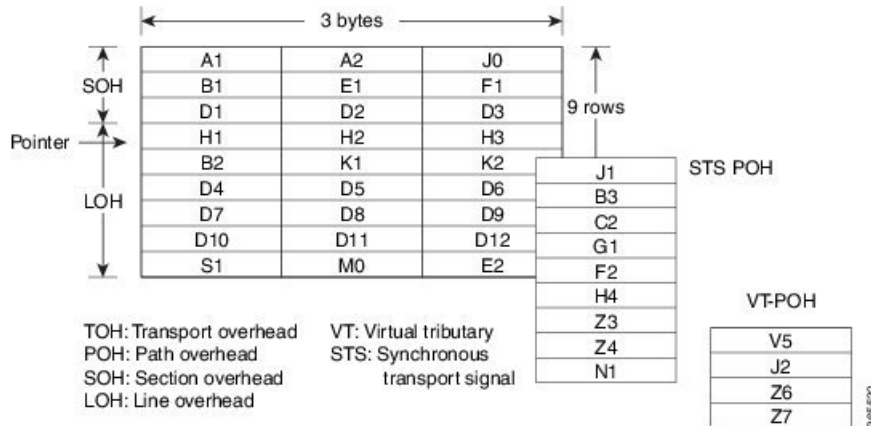

For STS-1, a single SONET frame is transmitted in 125 microseconds, or 8000 frames per second.  $8000 \text{ fps} * 810 \text{ B/frame} = 51.84 \text{ Mbs}$ , of which the payload is roughly 49.5 Mbs, enough to encapsulate 28 DS-1s, a full DS-3, or 21 CEPT-1s.

An STS-3 frame is nine rows by 270 bytes. The first nine columns contain the transport overhead section, and the rest is SPE. For both STS-3 and STS-3c, the transport overhead (Line and Section) is the same.

For an STS-3 frame, the SPE contains three separate payloads and three separate path overhead fields. In essence, it is the SPE of three separate STS-1s packed together, one after another.

For more information on Section Overhead, Line Overhead, and Path Overhead, refer the following:

- <http://www.cisco.com/c/en/us/support/docs/optical/synchronous-digital-hierarchy-sdh/5462-sdh-overview.html>
- <http://www.cisco.com/c/en/us/support/docs/optical/synchronous-optical-network-sonet/13567-sonet-tech-tips.html>
- <http://www.cisco.com/c/en/us/tech/optical/synchronous-optical-network-sonet/tsd-technology-support-troubleshooting-technotes-list.html>

## Concatenated SONET Frames

Twenty-eight VTs make up one STS-1. Three STS-1s made up an STS-3 and so on. Any one byte within the STS frame has a direct relationship to a base VT that helps to make up the STS.

A lower-case "c" in the STS rate stands for "concatenated", and indicates that the interface hardware is not channelized. Examples of concatenated interfaces are STS-3c and STS-12c.

The STS-1s may be concatenated into sets of 3 or 12 or 24 or 48 or 192 to form STS-3c, STS-12c, and so on. The STS-1s may be combined only at specific STS-n boundaries within an OC port.

## Channelized SONET Frames

A channelized SONET interface is a composite of lower-speed STS streams. However, a channelized SONET interface maintains the streams as independent frames with unique payload pointers. The frames are simply multiplexed before transmission to increase the carrying capacity of the physical fiber. This process is similar to multiplexing 24 digital signal level 0 channels into a DS1 or multiplexing 28 DS1 streams into a DS3.

## SDH Frame Structure

The STM-1 frame is the basic transmission format for SDH. The frame lasts for 125 microseconds, therefore, there are 8000 frames per second. The STM-1 frame consists of overhead plus a Virtual Container (VC) capacity.

The SDH frame consists of 270 columns. The first nine columns of each frame make up the Section Overhead, and the last 261 columns make up the VC capacity. The VC plus the pointers (H1, H2, H3 bytes) are called the Administrative Unit (AU). Carried within the VC capacity, which has its own frame structure of nine rows and 261 columns, is the Path Overhead and the Container. The first column is for Path Overhead; it is followed by the payload container, which can itself carry other containers. VCs can have any phase alignment within the Administrative Unit, and this alignment is indicated by the Pointer in row four. Within the Section Overhead, the first three rows are used for the Regenerator Section Overhead, and the last five rows are used for the Multiplex Section Overhead. The STM frame is transmitted in a byte-serial fashion, row-by-row, and is scrambled immediately prior to transmission to ensure adequate clock timing content for downstream regenerators.

Figure 3: STM1 Frame Structure

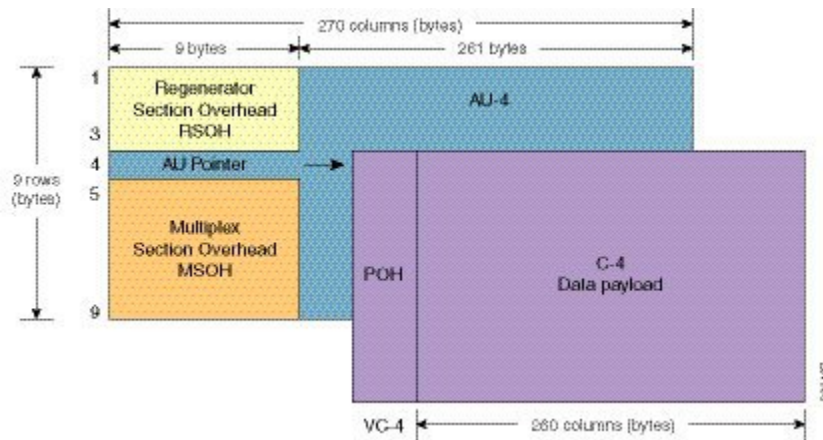
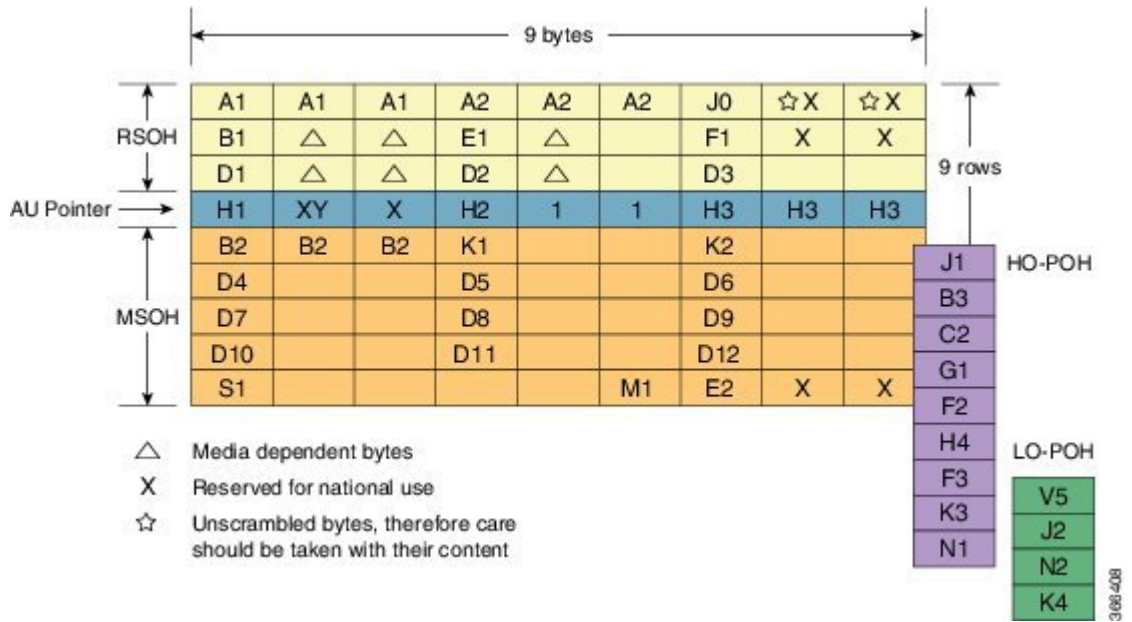

Figure 4: STM1 Section Overhead



## VC

SDH supports a concept called VC. Through the use of pointers and offset values, VCs can be carried in the SDH payload as independent data packages. VCs are used to transport lower-speed tributary signals. Note that it can start (indicated by the J1 path overhead byte) at any point within the STM-1 frame. The start location of the J1 byte is indicated by the pointer byte values. VCs can also be concatenated to provide more capacity in a flexible fashion.