



Cisco ASR 1002 Router Overview and Installation

This chapter describes the Cisco ASR 1002 Router and provides procedures for installing the Cisco ASR 1002 Router on an equipment shelf or tabletop or in an equipment rack.

This chapter contains the following sections:

- [Cisco ASR 1002 Router Description, on page 1](#)
- [Installation Methods, on page 12](#)
- [General Rack Installation Guidelines, on page 13](#)
- [Guidelines for an Equipment Shelf or Tabletop Installation, on page 14](#)
- [Equipment Shelf or Tabletop Installation, on page 15](#)
- [Rack-Mounting the Cisco ASR 1002 Router, on page 17](#)
- [Attaching the Chassis Rack-Mount Brackets, on page 18](#)
- [Installing the Cisco ASR 1002 Router in a Rack, on page 21](#)
- [Attaching the Cable-Management Bracket, on page 25](#)
- [Attaching a Chassis Ground Connection, on page 27](#)
- [Connecting the Shared Port Adapter Cables, on page 29](#)
- [Connecting the Console and Auxiliary Port Cables, on page 30](#)
- [Cisco ASR 1002 Router Power Supplies, on page 32](#)
- [Connecting a Terminal to the Cisco ASR1000-RP1 Console Port, on page 45](#)
- [Connecting Cables, on page 46](#)

Cisco ASR 1002 Router Description

The Cisco ASR 1002 Router is part of the Cisco aggregation services family of routers. The Cisco ASR 1002 Router offers a compact form factor router that satisfies customer demands such as low power consumption and decreased usage of rack space.

The Cisco ASR 1002 Router supports three half-height SPAs and an optional built-in 4xGE SPA. The Cisco ASR 1002 Router supports all the general-purpose routing and security features of the Cisco ASR 1000 Series Routers. It uses the same internal control and data-plane architecture as the other Cisco ASR 1000 Series Routers.

The Cisco ASR 1002 Router supports:

- Cisco ASR1000-ESP5 or Cisco ASR1000-ESP10 as a field-replaceable unit (FRU)

- The Cisco Embedded Route Processor which supports 2MB upgradeable BootROM and 8 GB eUSB bulk storage.
- 1 + 1 redundant AC or DC power supplies.
- Stratum-3 network clocking per GR-1244-CORE, with T1/E1 BITS interface or SPAs as timing sources.
- A built-in 4x1GE SPA providing four small form-factor pluggable (SFP-based) GE connections, designated as SPA bay 0.

For information about the SFP transceiver modules that are compatible with Cisco ASR 1002 Built-in Gigabit Ethernet Ports (4x1GE), refer to the “Modular Optics Compatibility” section in Cisco ASR 1000 Series Aggregation Services Routers SIP and SPA Hardware Installation Guide .

The Cisco ASR 1002 Router supports upgradeable Cisco ASR1000-ESP5 or ASR1000-ESP10 assembly and the power supply modules as field-replaceable units. The Cisco integrated ASR1000-SIP10 and Cisco built-in ASR1000-RP1 assemblies are fixed into the chassis and are not upgradeable; but the shared port adapters in the SIP are field upgradable.

This section contains the following topics:

- [Front View, on page 2](#)
- [Rear View, on page 3](#)
- [Cisco ASR 1002 Router Slot Numbering, on page 4](#)

Front View

Cisco ASR 1002 router front view shows the Cisco ASR 1002 Router with modules installed.

Figure 1: Cisco ASR 1002 Router—Front View

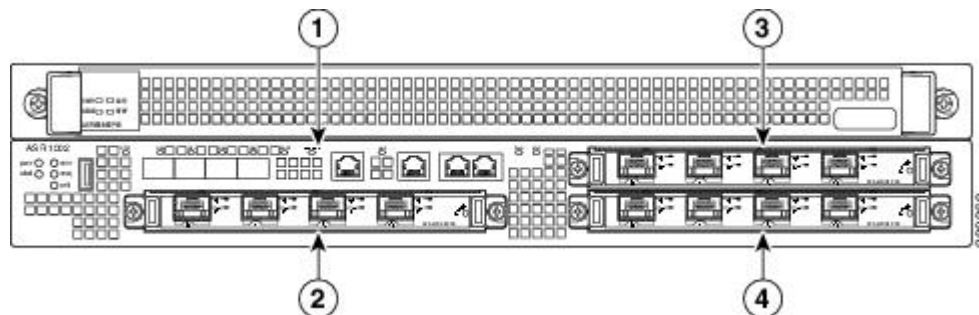

1	Embedded ASR 1000 Series Route Processor in the subslot and represents the built in 4xGE SPA.	3	SPA subslot 1
2	SPA subslot 2	4	SPA subslot 3



Note The SPAs in subslots 1-3 are field upgradeable. The SIP that the SPAs reside in is not field-upgradeable and the Cisco ASR 1000 Series Route Processor is embedded in the chassis and not field upgradeable.

Rear View

Cisco ASR 1002 router AC power supply image shows the Cisco ASR 1002 Router AC power supply.

Figure 2: Cisco ASR 1002 Router AC Power Supply

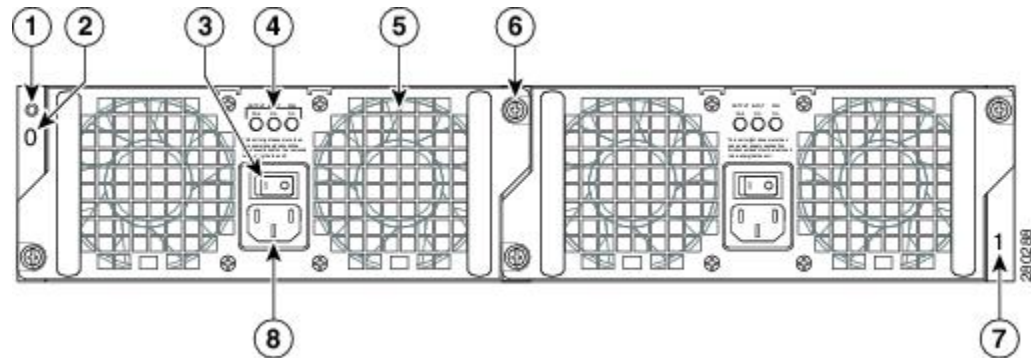

1	Chassis ESD socket	5	AC power supply fan
2	AC power supply slot number 0	6	AC power supply captive installation screw
3	AC power supply On (I) /Off (O) switch	7	AC power supply slot number 1
4	AC power supply LEDs	8	AC power inlet

c_Rear_View_1271213.xml shows the Cisco ASR 1002 Router DC power supply.

Figure 3: Cisco ASR 1002 Router DC Power Supply

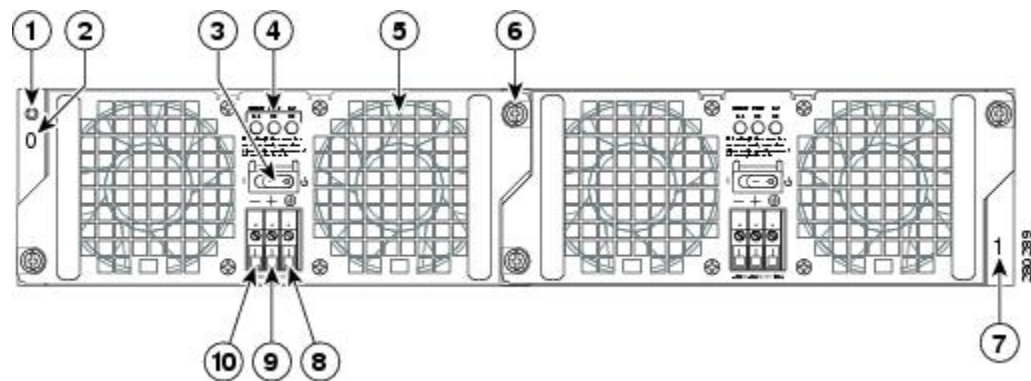

1	Chassis ESD socket	6	DC power supply captive installation screw
2	DC power supply slot 0 label	7	DC power supply slot 1 label
3	DC power supply switch Standby/On (I)	8	Ground lead
4	DC power supply LEDs	9	Positive lead
5	Power supply fan	10	Negative lead

Internal fans draw cooling air into the chassis and across internal components to maintain an acceptable operating temperature. The fans are located at the rear of the chassis. A two-hole grounding lug is located on the side of the chassis. Two power supplies, either two AC power supplies or two DC power supplies are accessed from the rear of the router.



Caution Use only AC power supplies or DC power supplies in the Cisco ASR 1002 Router. Do not mix power supply types.

Cisco ASR 1002 Router Slot Numbering

The Cisco ASR 1002 Router contains one Cisco embedded ASR1002-RP1 which is addressed as R0 and one Cisco ASR1000-ESP5 or ASR1000-ESP10 forwarding processor in slot F0. The Cisco ASR 1002 Router consists of an embedded ASR1000-RP1 and embedded ASR1000-SIP10 board supporting three half-height SPAs or 1 half-height and one full-height SPA and one Cisco ASR1000-ESP5 forwarding processor.

The SPA bays are bay 1, bay 2, and bay 3. The built-in 4xGE SPA ports are located in the SPA 0 location and will be addressed as GE 0/0/x. The Cisco ASR 1002 Router provides a built-in 4-Gigabit Ethernet interface and this SPA is physically located on the Cisco embedded ASR1000-RP1 board. The Cisco ASR 1000 Series ESP card is located in slot 1 and labeled as FP0.

c_Cisco_ASR_1002_Router_Slot_Numbering_1243123.xml shows the Cisco ASR 1002 Router slot numbering.

Figure 4: Cisco ASR 1002 Router Slot Numbering

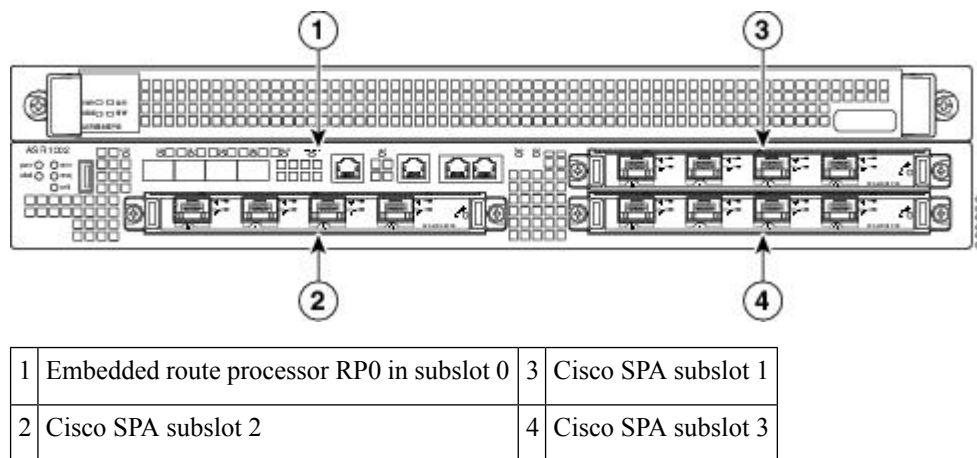

Cisco ASR 1002 Router Components

The Cisco ASR 1002 Router system is derived from the architecture of the other Cisco ASR 1000 Series routers. The three main subassemblies of any Cisco ASR 1000 Series Routers are all supported in the Cisco ASR 1002 Router, which is the:

- C
isco embedded ASR1000-RP1 and Cisco embedded ASR1000-SIP10 (not field upgradable)
- Cisco ASR1000-ESP5 and Cisco ASR1000-ESP10 embedded services processors are field-replaceable units (FRU)

- AC or DC power supplies which are field-replaceable units

Cisco Embedded ASR1000-RP1 for Cisco ASR 1002 Router Description

The Cisco ASR 1000 Series route processor (embedded for the Cisco ASR 1002 Router) is the central control processor and runs the network operating system.

The Cisco embedded ASR1000-RP1 supports management interfaces such as the Ethernet network management port and console and auxiliary serial ports. It has LED status indicators, an RJ-45 plug for a BITS timing reference and one USB port which can be used with smart cards for secure key distribution or for image or configuration file updates.

The Cisco embedded ASR1000-RP1 deviates from the other ASR Series Route Processor 1 for the Cisco ASR 1006 router and the Cisco ASR 1004 Router in the following ways:

- Bulk file storage is on a large eUSB device (to 8 GB supported) with no SATA hard-drive supported.
- Redundant Cisco Route Processor 1 is not supported.
- Network clock changes. No second BITS clock input supported.
- A built-in 4x1GE SPA is included. This shared port adapter provides four SFP-based GE connections.

For information about the SFP transceiver modules that are compatible with Cisco ASR 1002 Built-in Gigabit Ethernet Ports (4x1GE), refer to the “Modular Optics Compatibility” section in [Cisco ASR 1000 Series Aggregation Services Routers SIP and SPA Hardware Installation Guide](#).

Cisco Embedded ASR1000-SIP10 and SPAs for Cisco ASR 1002 Router Description

The Cisco embedded ASR1000-SIP10 in the Cisco ASR 1002 Router is built into the Cisco ASR 1002 Router. The Cisco embedded ASR1000-SIP10 provides the physical and electrical termination for up to three half-height SPAs or one full-height and one half-height SPA. Double-wide SPAs are not supported. The fourth SPA slot is connected to the built-in 4xGE SPA that resides on the Cisco embedded ASR1000-RP1.

The Cisco embedded ASR1000-SIP10 interface, like the Cisco ASR 1006 Router and Cisco ASR 1004 Router, supports all Cisco embedded ASR1000-SIP10 functions and services. However, the Cisco embedded ASR1000-SIP10 differs in the following areas:

- Functions as the base board for Cisco embedded ASR1000-RP1
- Only supports three removable half-height SPAs on Bay 1, 2, and 3. The fourth SPA is a built-in 4xGE SPA on Bay 0, which is located on the Cisco embedded ASR1000-RP1.
- Is not a field-replaceable unit (FRU) and does not support online insertion and removal (OIR).



Note The shared port adapters (SPAs) on the Cisco embedded ASR1000-SIP10 in the Cisco ASR 1002 Router do support online insertion and removal.

The Cisco ASR 1002 Router embedded ASR1000-RP1 also provides the circuitry for the built-in 4xGE SPA.

Cisco ASR1000-ESP5 and ASR1000-ESP10 Description

The Cisco ASR 1002 Router supports the Cisco ASR1000-ESP5 or Cisco ASR1000-ESP10 embedded services processors. The Cisco ASR 1002 Router does not support the Cisco ASR1000-ESP20.

Cisco ASR1000-ESP10 image shows the LEDs on the Cisco ASR1000-ESP10.

Figure 5: Cisco ASR1000-ESP10 LEDs

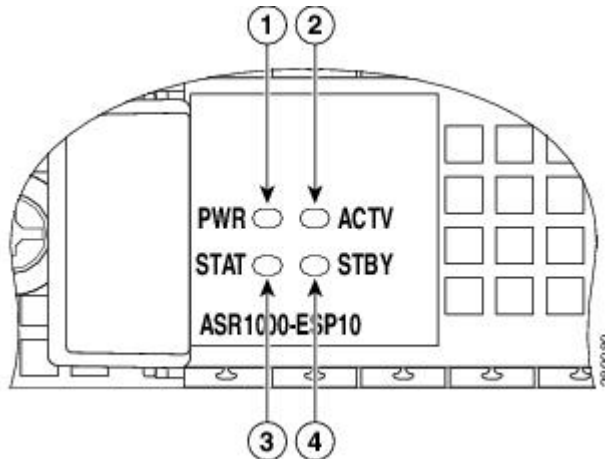

c_Cisco_ASR1000-ESP5_and_ASR1000-ESP10_Description_1222814.xml describes the Cisco ASR1000-ESP5 and Cisco ASR1000-ESP10 LEDs.

Table 1: Cisco ASR1000-ESP5 and Cisco ASR1000-ESP10 LEDs

No.	LED Label	LED	Color	Behavior in the Power-Up State
1	PWR	Power	Solid green	All power supplies are within operational limits.
			Off	Off, the router is in standby mode.
2	ACTV	Active	Green	The embedded services processor is green when active.
3	STAT	STATUS	Green	Code has successfully downloaded and is operational.
			Yellow	BOOT ROM has successfully loaded.
			Red	Not booted.
4	STBY	Standby	None	Will always be off.



Note The Cisco ASR 1000-ESP5 can only be used in the Cisco ASR 1002 Router.

Power Supplies in the Cisco ASR 1002 Router

The Cisco ASR 1002 Router power supply module supports the following Cisco power supplies:

- AC power supply operates between 85VAC to 264VAC and DC operates between -40.5 to -72 VDC
- -48 VDC power supply operates between
- $+24$ VDC power supply operates

The power supplies are installed into the rear of the chassis and are hot pluggable. The Cisco ASR 1002 Router supports up to 588 W input power from an infrastructure standpoint (cooling capacity, midplane and power distribution) but initial power supply development limit is up to 470 W output (AC and DC Input).

AC Power Supply for Cisco ASR 1002 Router

The AC power supply input inlet is an IEC connector with AC switch and the current rating on the connector and switch is 10 Amps. The AC power supply is secured into the chassis with two captive screws mounted on the faceplate.

The following table describes the AC power supply LEDs on the Cisco ASR 1002 Router.

Table 2: Cisco ASR 1002 Router AC Power Supply LEDs

LED Label	LED	Color	Description
INPUT OK	Power supply activity	Green	The AC input voltage is greater than 85V.
		None	If the LED is not illuminated, then either the input voltage is less than 70V, or the power supply is turned off. If the AC input voltage is between 70V and 85V, the INPUT OK LED can be on, off, or flashing.
FAN OK	Power supply fan activity A bi-color LED indicates fan status.	Green	All fans are operational.
		Red	A fan failure is detected.
OUTPUT FAIL	Power supply activity	Red	If the INPUT OK LED is illuminated, this LED is red if the DC output voltages are below the minimum limit or above the maximum limit. If the INPUT OK LED is not illuminated, this LED might be off or red.

The following image shows the AC Power Supply for the Cisco ASR 1002 Router.

Figure 6: AC Power Supply for the Cisco ASR 1002 Router

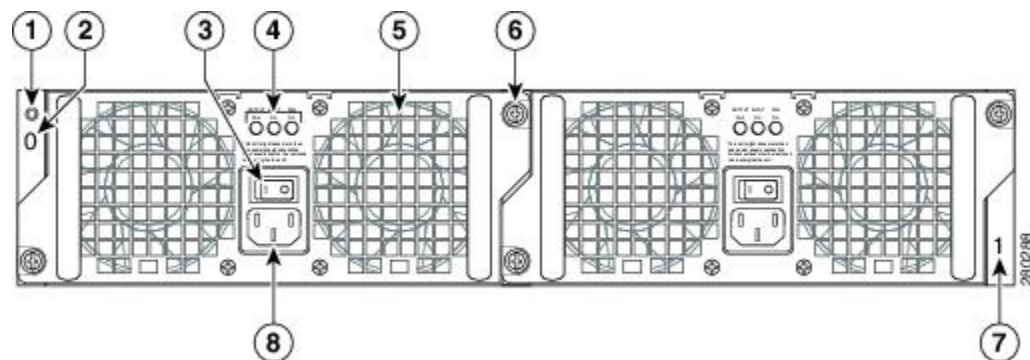

1	Chassis ESD socket	5	AC power supply fan
2	AC power supply slot number 0	6	AC power supply captive installation screw
3	AC power supply On (I) /Off (O) switch	7	AC power supply slot number 1
4	AC power supply LEDs	8	AC power supply inlet

48 VDC Power Supply for Cisco ASR 1002 Router

The –48 VDC power supply input connector is a Euro-style terminal block. It is compliant with safety agencies' guidelines and electrical requirements of the supply. The DC power supply operates within specification from –40.5VDC to –72VDC continuously once the power supply DC input turn on threshold of –43.5 V has been reached.

The –48 VDC power input connector Euro-style terminal block will accept three wires: one positive polarity, one negative polarity, and one ground wire. There are provisions on the front panel to wire tie and strain relief the DC input wiring. The connection order is negative (–), positive (+), and GND. The DC power supply is secured into the system chassis with two captive screws mounted on the faceplate.

The following image shows the –48 VDC Power Supply for the Cisco ASR 1002 Router.

Figure 7: –48 VDC Power Supply for the Cisco ASR 1002 Router

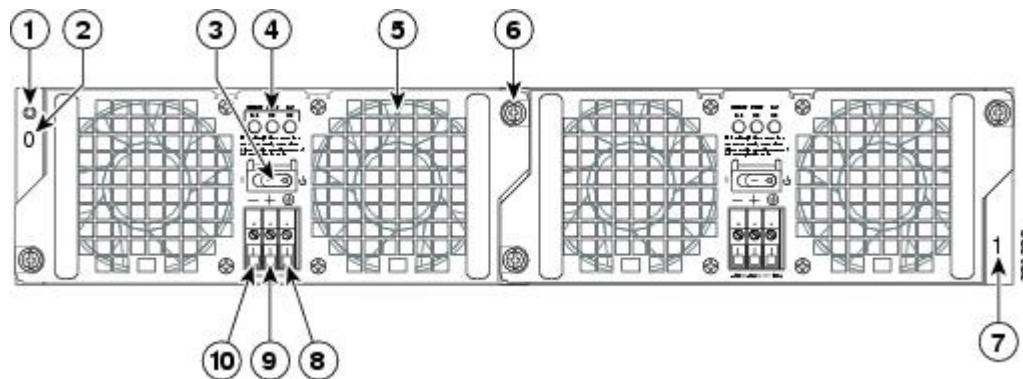

1	Chassis ESD socket	6	Power supply captive installation screw
2	Power supply slot 0 label	7	Power supply slot 1 label
3	Power supply switch Standby/On (I)	8	Ground lead
4	Power supply LEDs	9	Positive lead
5	Fan	10	Negative lead

The Cisco ASR 1002 Router –48 VDC power supply LEDs are described in the following table.

Table 3: Cisco ASR 1002 Router –48 VDC Power Supply LEDs

LED Label	LED	Color	Description
INPUT OK	A bi-color LED indicates presence of input voltage	Green	LED illuminates green to signal that the DC power supply input voltage is greater than 43.5VDC at turn-on and remains green down to 39VDC.
		Amber	The LED illuminates amber if the power supply turns off due to low input voltage (falls below 39VDC) and indicates that there is still a hazard present (voltage on the terminal block). The LED remains amber and is active to around 20 V +/-5 V. The LED is not illuminated if the input is below 15 V.
FAN OK	A bi-color LED indicates power supply fan status	Green	The LED illuminates green when all fans are operational.
		Red	The LED illuminates red when a fan failure is detected.
OUTPUT FAIL	Power supply activity	Red	<p>When the LED is off, it signals that the DC output voltage are within the normal operating range. Output voltage between the minimum and maximum limits will not create an output fail alarm, and output voltages below the minimum or above the maximum will create an Output Fail alarm.</p> <p>Led illuminates red to indicate that the DC output is out of the specified range.</p> <p>When you turn the power supply on, the red LED illuminates for two to three seconds to test LED operation before going off.</p>

The output voltage alarm is declared when the output voltage is below the low end of the minimum or above the high end of the maximum limits. When the output voltage is above the high end of the minimum or below the low end of the maximum limits, the red state will not be activated.

The following table shows the –48 VDC power supply output voltage alarm range.

Table 4: –48 VDC Power Supply Output Voltage Alarm Threshold Ranges

Output	Minimum	Maximum
12V	10.0-11.2V	12.8-13.8V
3.3V	2.6 - 3.0 V	None

24 VDC Power Supply for Cisco ASR 1002 Router

This section provides information about the +24 VDC power supplies on the rear of the Cisco ASR 1002 Router. The recommended branch circuit breaker for the Cisco ASR 1002 Router +24 VDC power supply is a 40 A UL listed circuit breaker.

The Cisco ASR 1002 Router has two of the same type power supplies in power supply slot 0 and power supply slot 1. The power supply slot identifiers are zero (0) on the left side of the chassis rear and one (1) on the right side of the chassis rear. The power supply switch is a Standby switch and is not considered a disconnect.

The +24 VDC power supply uses a spring-loaded terminal block. The input terminal block requires maximum 8AWG multi-strand wiring to support input current. The terminal block is compliant with safety agencies' guidelines and electrical requirements of the supply. Use the tie wraps to dress the input cable wires; there are two tie wrap tabs on the +24 VDC power supply. The +24 VDC power supply unit is secured into the system chassis with two captive screws mounted on the faceplate.

The following image shows the +24 VDC Power Supply for the Cisco ASR 1002 Router.

Figure 8: Cisco ASR 1002 Router +24 VDC Power Supply

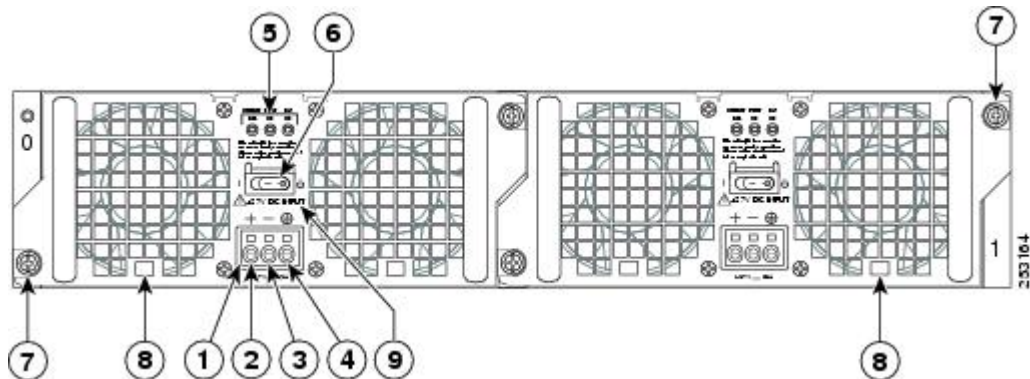

1	+24 VDC terminal block	6	Standby/On switch
2	Positive (+) lead	7	Captive fastener
3	Negative (-) lead	8	Power supply tabs
4	Ground (GND) lead	9	+27 VDC INPUT label
5	Power supply LEDs	—	—

The Cisco ASR 1002 Router +24 VDC power supply LEDs are defined in the following table.

Table 5: Cisco ASR 1002 Router +24 VDC Power Supply LEDs

LED Label	LED	Color	Description
OUTPUT FAIL	Power supply activity	Red	When the LED is off, it signals that the +24 VDC output voltage are within the normal operating range. Output voltage between the minimum and maximum limits will not create an output fail alarm, and output voltages below the minimum or above the maximum will create an Output Fail alarm. When you turn the power supply on, the red LED illuminates for two to three seconds to test LED operation before going off.
INPUT OK	A bi-color LED indicates presence of input voltage	Green	LED illuminates green to signal that voltage is > or = to 20VDC at turn-on and down to 19.0VDC (+/- 0.5 V tolerance).
		Amber	The LED illuminates amber when the input voltage is active down to 16.0VDC and indicates that there is still a voltage present (voltage on the terminal block). The LED remains amber and is active to around 10 V. The LED can be OFF below 15.8VDC.
FAN OK	A bi-color LED indicates power supply fan status	Green	The LED illuminates green when all fans are operational.
		Red	The LED illuminates red when a fan failure is detected.

24 VDC Power System Input for Cisco ASR 1002 Router

The +24 VDC power supply operates within specification between +21 and +36 VDC continuously once the power supply DC input is turned on. The power supply shall measure the input voltage at the terminals of the power supply and turn off the supply when the input voltage reaches 19.0 volts +/- 0.5 volts. Once this low voltage threshold is reached, the power supply does not resume operation until the input voltage has reached 20.0 volts +/- 0.5 volts. Once the turn-on threshold of 20 volts is reached, then the +24 VDC power supply meets all specification requirements down to low voltage threshold of 19 volts (+/- tolerance).

+24 VDC Power System Output for Cisco ASR 1002 Router

The +24 VDC power supply output tolerance is defined in Cisco ASR 1002 Router +24 VDC Power System Output Voltage and Current table under all combinations of +24 VDC input line variation. Total system power consumption should not exceed 470 watts or output rating of each power supply.



Note Two power supplies are used for redundant operation. System total power consumption shall never exceed rating of one power supply to maintain redundancy.

Table 6: Cisco ASR 1002 Router +24 VDC Power System Output Voltage and Current

Output Voltage	+12VDC	+3.3 V
Minimum	11.80	3.20
Nominal	12.00	3.30
Maximum	12.20	3.40
Output Current		
Minimum	2.0 A	0.10 A
Maximum	39 A	3.125 A



Note Any combination of output voltage/currents cannot exceed total power rating of 470 Watts.

+24 VDC Power Supply Important Notices

The following items list important notes regarding the +24 VDC power supply in the Cisco ASR 1002 Router:

- **Output Voltage Alarm Threshold**—The Output Voltage Alarm is declared when the output voltage is below the low end of the minimum or above the high end of the maximum limits (as shown in VDC Output Voltage Alarm Threshold Ranges table). When the output voltage is above the high end of the minimum or below the low end of the maximum limits, then the Red state is not activated.

Table 7: +24 VDC Output Voltage Alarm Threshold Ranges

Output	Minimum	Maximum
12V	10.0-11.2V	12.8-13.8V
3.3V	2.6 – 3.0V	None

- **Temperature**—If a single fan fails, the power supply meets the functional requirements specified in Table 24. Above 55°C with less than two fans, calculated MTBF does not apply; however all component stress remains within the manufacturer’s specified rating.
- **Thermal Shutdown**—The +24 VDC power supply will shut down to protect its components due to excessive internal temperature. The +24 VDC power supply then automatically restarts if the internal temperature returns to a safe operating level.

Power Cords Supported by the Cisco ASR 1002 Router

The following table lists the power cords that are supported by the Cisco ASR 1002 Router.

Table 8: Power Cords Supported by the Cisco ASR 1002 Router

Power Cord Item Number	Description
CAB-AC-RA	Power Cord, 110 V, Right Angle
CAB-ACA-RA	Plug, Power Cord, Australian, 10 A, Right Angle
CAB-ACB10A-RA	Power Cord, Brazil, Right Angle, 10 A
CAB-ACC-RA	Power Cord China, Right Angle
CAB-ACE-RA	Power Cord Europe, Right Angle
CAB-ACI-RA	Power Cord, Italian, Right Angle
CAB-ACR-RA	Power Cord Argentina, Right Angle
CAB-ACS-RA	Power Cord, Switzerland, Right Angle
CAB-ACU-RA	Power Cord UK, Right Angle
CAB-IND-RA	Power Cord India, Right Angle
CAB-JPN-RA	Power Cord-Japan, Right Angle

Installation Methods

Cisco ASR 1002 Router is designed for standalone, two rail 19-inch rack-mount (front rail only), four rail 19-inch rack-mount (front and rear rail).

Although rack-mounting is the preferred method of installation for the Cisco ASR 1002 Router, you can mount the chassis on an equipment shelf or tabletop.



Note The Cisco ASR 1002 Router usually ships fully loaded. However, you can remove components from the chassis to make the chassis lighter for your rack installation, such as the power supplies.



Warning This warning symbol means danger. You are in a situation that could cause bodily injury. Before you work on any equipment, be aware of the hazards involved with electrical circuitry and be familiar with standard practices for preventing accidents. Use the statement number provided at the end of each warning to locate its translation in the translated safety warnings that accompanied this device. Statement 1071



Warning Before you install, operate, or service the system, read the *Regulatory Compliance and Safety Information for Cisco ASR 1000 Series Aggregation Services Routers* publication. This document provides important safety information you should know before working with the system. Statement 200



Note You have already unpacked your chassis and read all the site requirements for your new equipment. Proceed with the installation.

General Rack Installation Guidelines

When planning your rack installation, consider the following guidelines:

- The Cisco ASR 1002 Router requires a minimum of 3.5 inches or 8.9 cm rack units of vertical rack space. Measure the proposed rack location before mounting the chassis in the rack.
- Before using a particular rack, check for obstructions (such as a power strip) that could impair rack-mount installation. If a power strip does impair a rack-mount installation, remove the power strip before installing the chassis, and then replace it after the chassis is installed.
- Allow sufficient clearance around the rack for maintenance. If the rack is mobile, you can push it back near a wall or cabinet for normal operation and pull it out for maintenance (installing or moving cards, connecting cables, or replacing or upgrading components). Otherwise, allow 19 inches (48.3 cm) of clearance to remove field-replaceable units.
- Maintain a minimum clearance of 3 inches on the front and back sides of the chassis for the cooling air inlet and exhaust ports, respectively. Avoid placing the chassis in an overly congested rack or directly next to another equipment rack; otherwise, the heated exhaust air from other equipment can enter the inlet air vents and cause an overtemperature condition inside the router.



Caution To prevent chassis overheating, never install a Cisco ASR 1002 Router in an enclosed room that is not properly ventilated or air conditioned.

- Always install heavier equipment in the lower half of a rack to maintain a low center of gravity to prevent the rack from falling over.
- Install and use the cable-management brackets included with the Cisco ASR 1002 Router to keep cables organized and out of the way of the cards and processors. Ensure that cables from other equipment already installed in the rack do not impair access to the cards or require you to disconnect cables unnecessarily to perform equipment maintenance or upgrades.
- Install rack stabilizers (if available) before you mount the chassis.
- Provide an adequate chassis ground (earth) connection for your router chassis.

In addition to the preceding guidelines, review the precautions for avoiding excessive temperature conditions in the Site Environmental Requirements” section on page 5-9 .

The following table provides the Cisco ASR 1002 Router dimensions and weight information.

Table 9: Cisco ASR 1002 Router Dimensions and Weight

Cisco ASR 1002	Dimensions
Depth	22.50 in. (57.15 cm)(including card handles, cable-management brackets, power supply handles).
Height	3.47 in. (8.813 cm) - 2RU rack-mount per EIA RS-310
Width	17.25 in. (43.815 cm) - 19 inch rack-mount
Weight	40 lb (18.143 k) - fully configured

Guidelines for an Equipment Shelf or Tabletop Installation

The chassis should already be in the area where you will install it. If you have not determined where to install your chassis, see the Cisco ASR 1000 Series Routers Component Overview” section on page 2-1 for information about site considerations.

If you are not rack-mounting your Cisco ASR 1000 series chassis, place it on a sturdy equipment shelf or tabletop.

When installing the Cisco ASR 1002 Router on an equipment shelf or tabletop, ensure that the surface is clean and that you have considered the following:

- The Cisco ASR 1002 Router requires at least 3 inches (7.62 cm) of clearance at the inlet and exhaust vents (the front and top/rear sides of the chassis).
- The Cisco ASR 1002 Router should be installed off the floor. Dust that accumulates on the floor is drawn into the interior of the router by the cooling fans. Excessive dust inside the router can cause overtemperature conditions and component failures.
- There must be approximately 19 inches (48.3 cm) of clearance at the front and rear of the chassis to install and replace FRUs, or to access network cables and equipment.
- The Cisco ASR 1002 Router needs adequate ventilation. Do not install it in an enclosed cabinet where ventilation is inadequate.

- Have the cable-management bracket available if you plan to install it on the front of the chassis.
- An adequate chassis ground (earth) connection exists for your router chassis (see the [Attaching a Chassis Ground Connection](#), on page 27 section).
- Always follow proper lifting practices as outlined in the Electrical Safety” section on page 5-21 , when handling the chassis.

Equipment Shelf or Tabletop Installation

To mount your Cisco ASR 1002 Router on an equipment shelf or tabletop, follow these steps.

Remove any debris and dust from the tabletop or platform, as well as the surrounding area. Lift the chassis into position on the equipment shelf or tabletop (see Equipment Shelf for Tabletop Installation image .



Warning

At least two people are required to lift the chassis onto a tabletop or platform. To prevent injury, keep your back straight and lift with your legs, not your back. Statement 164 The chassis in the following image does not represent the Cisco ASR 1002 Router.

Figure 9: Lifting the Chassis

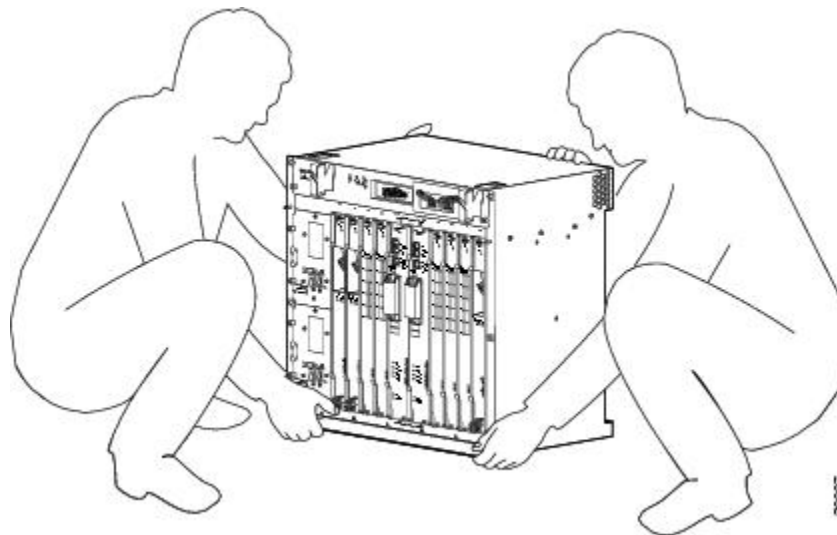

SUMMARY STEPS

1. Attach the front rack-mount brackets. Locate the threaded holes in the front sides of the chassis (first holes beyond the vent holes) and use the package of black screws that shipped with the chassis.
2. Align the front rack-mount bracket to one side of the chassis.
3. Insert and tighten the screws on one side.
4. Repeat Step 2 through Step 3 on the other side of the chassis. Use all screws to secure the rack-mount brackets to the chassis.

5. Gather the two cable-management brackets and screws shipped with your chassis. [t_Equipment_Shelf_or_Tabletop_Installation_9100430.xml](#) shows cable-management brackets attached on the front of the Cisco ASR 1002 Router.
6. Screw the cable-management bracket to each side of the rack-mount brackets already attached to the chassis. Use two screws for each cable-management bracket. Use the package of four screws.
7. Check that all screws are securely tightened.
8. Go to [Attaching a Chassis Ground Connection, on page 27](#) to continue the installation.

DETAILED STEPS

Step 1 Attach the front rack-mount brackets. Locate the threaded holes in the front sides of the chassis (first holes beyond the vent holes) and use the package of black screws that shipped with the chassis.

Step 2 Align the front rack-mount bracket to one side of the chassis.

Step 3 Insert and tighten the screws on one side.

Step 4 Repeat Step 2 through Step 3 on the other side of the chassis. Use all screws to secure the rack-mount brackets to the chassis.

Note: The chassis rack-mount brackets must be installed first so that you can attach the cable-management brackets to the chassis rack-mount brackets after the chassis is installed in the rack.

Step 5 Gather the two cable-management brackets and screws shipped with your chassis.

[t_Equipment_Shelf_or_Tabletop_Installation_9100430.xml](#) shows cable-management brackets attached on the front of the Cisco ASR 1002 Router.

Note Make certain that the cable-management ‘U’ feature device has the open end pointing upwards when you attach it to the chassis

Figure 10: Attaching the Cable-Management Brackets to the Cisco ASR 1002 Router

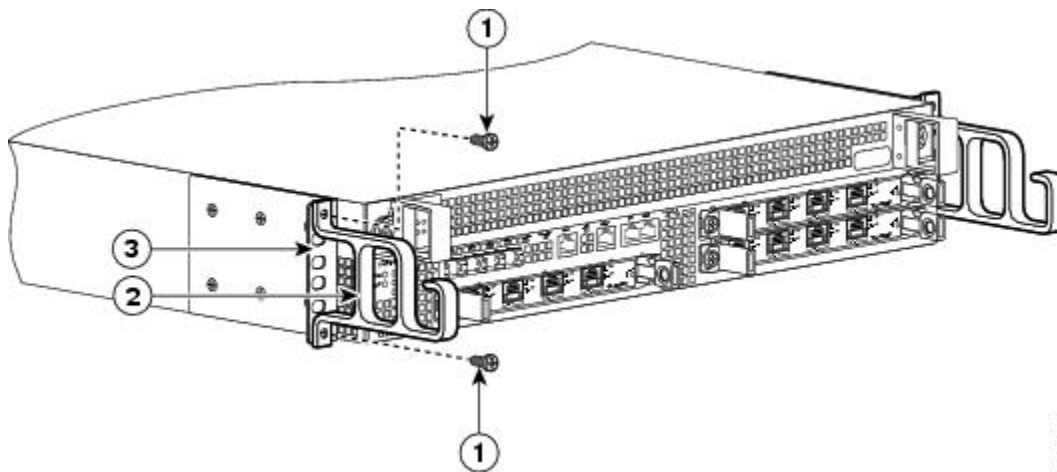

1	Cable-management bracket top and bottom screw	3	Chassis front rack-mount bracket
2	Cable-management bracket	—	—

Step 6 Screw the cable-management bracket to each side of the rack-mount brackets already attached to the chassis. Use two screws for each cable-management bracket. Use the package of four screws.

Step 7 Check that all screws are securely tightened.

Step 8 Go to [Attaching a Chassis Ground Connection, on page 27](#) to continue the installation.

Rack-Mounting the Cisco ASR 1002 Router

The Cisco ASR 1002 Router can be installed in an existing rack with equipment or in an empty rack with no equipment: The chassis can be mounted in either rack types:

- Two-post rack, either 19 inch or 23 inch. Inner clearance (the width between the inner sides of the two posts or rails) must be at least 19 inches (48.26 cm). The height of the chassis is 3.47 inches (8.8 cm). Airflow through the chassis is from front to back.



Note If you are using a two-post rack secure the rack to the floor surface to prevent tipping and avoid bodily.

- Four post, 19-inch equipment rack. Inner clearance (the width between the inner sides of the two posts or rails) must be at least 19 inches (48.26 cm). The height of the chassis is 3.47 inches (8.8 cm). Airflow through the chassis is from front to back.



Note When handling the chassis, always follow proper lifting practices. See the Chassis-Lifting Guidelines” section on page 5-23 .

The Cisco ASR 1002 Router can be installed with both front or rear rack-mount brackets.

Verifying Rack Dimensions

Before you install the chassis, measure the space between the vertical mounting flanges (rails) on your equipment rack to verify that the rack conforms to the measurements shown in [t_Verifying_Rack_Dimensions_1202731.xml](#).

SUMMARY STEPS

1. Mark and measure the distance between two holes on the left and right mounting rails.
2. Measure the space between the inner edges of the left front and right front mounting flanges on the equipment rack.

DETAILED STEPS

Step 1 Mark and measure the distance between two holes on the left and right mounting rails.

The distance should measure 18.31 inches ± 0.06 inches (46.5 cm ± 0.15 cm).

Note Measure for pairs of holes near the bottom, middle and top of the equipment rack to ensure that the rack posts are parallel.

- Step 2** Measure the space between the inner edges of the left front and right front mounting flanges on the equipment rack. The space must be at least 17.7 inches (45 cm) to accommodate the chassis which is 17.25 inches (43.8 cm) wide and fits between the mounting posts on the rack.

Figure 11: Verifying Equipment Rack Dimensions

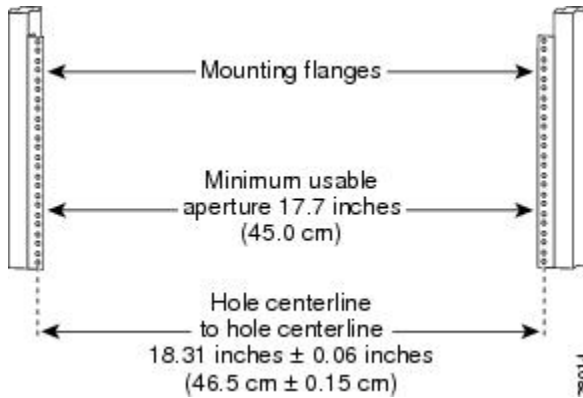

Attaching the Chassis Rack-Mount Brackets

This section explains how to attach the front and rear rack-mount brackets to the chassis. Before installing the chassis in the rack, you must install the rack-mount brackets on each side of the chassis.

The parts and tools required for installing the rack-mount brackets and cable-management brackets are listed in the Tools and Equipment” section on page 5-23 .



Note The cable-management brackets are attached to the chassis after you install the chassis rack-mount brackets on the chassis and mount the chassis in the rack.

Chassis Front Rack-Mount Brackets

Determine where in the rack you want the chassis to be mounted. If you are mounting more than one chassis in the rack, then start from the bottom up or the center of the rack.

t_Chassis_Front_Rack-Mount_Brackets_1106715.xml shows the brackets attached to the chassis. Depending on the bracket holes you use, the chassis may protrude in the rack.

To install the front rack-mount brackets on the Cisco ASR 1002 Router, perform the following steps:

SUMMARY STEPS

1. Locate the threaded holes on the side of the chassis. Make certain that you hold the front rack-mount bracket with the ear and holes facing outward and towards the front of the chassis.
2. Position the front rack-mount bracket top hole with the chassis first top hole behind the side vent holes.
3. Insert and tighten the black screws on one side.

4. Repeat Step 1 through Step 3 on the other side of the chassis. Use black screws to secure the rack-mount brackets to the chassis.
5. Install the chassis in a rack. To install the Cisco ASR 1002 Router in a rack, go to the [Installing the Cisco ASR 1002 Router in a Rack, on page 21](#).

DETAILED STEPS

Step 1 Locate the threaded holes on the side of the chassis. Make certain that you hold the front rack-mount bracket with the ear and holes facing outward and towards the front of the chassis.

The following image shows where to attach the front rack-mount brackets to the Cisco ASR 1002 Router.

Figure 12: Attaching the Front Rack-Mount Brackets to the Cisco ASR 1002 Router

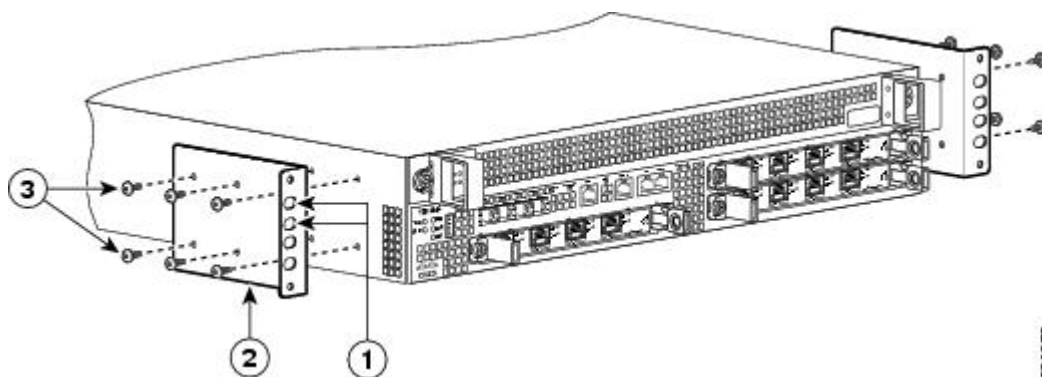

1	Front rack-mount bracket ear and holes	3	Front rack-mount bracket screws
2	Front rack-mount bracket		

Step 2 Position the front rack-mount bracket top hole with the chassis first top hole behind the side vent holes.

Step 3 Insert and tighten the black screws on one side.

Step 4 Repeat Step 1 through Step 3 on the other side of the chassis. Use black screws to secure the rack-mount brackets to the chassis.

Step 5 Install the chassis in a rack. To install the Cisco ASR 1002 Router in a rack, go to the [Installing the Cisco ASR 1002 Router in a Rack, on page 21](#).

Chassis Rear Rack-Mount Brackets

If you are rack-mounting the chassis using the rear rack-mount brackets, then this type of installation provides for the chassis being recessed in the rack.

To install the rear rack-mount brackets on the Cisco ASR 1002 Router, perform the following steps:

SUMMARY STEPS

1. Locate the threaded holes on the rear side of the chassis. Make certain that you hold the rear rack-mount bracket with the ear and holes facing outward and towards the rear of the chassis.

2. Position the rear rack-mount bracket top hole with the chassis top hole from the back.
3. Insert and tighten the screws on one side.
4. Repeat Step 1 through Step 3 on the other side of the chassis. Use the remaining screws to secure the rear rack-mount brackets to the chassis.

DETAILED STEPS

Step 1 Locate the threaded holes on the rear side of the chassis. Make certain that you hold the rear rack-mount bracket with the ear and holes facing outward and towards the rear of the chassis.

The following shows where to attach the rear rack-mount brackets to the Cisco ASR 1002 Router.

Figure 13: Attaching the Rear Rack-Mount Brackets to the Cisco ASR 1002 Router

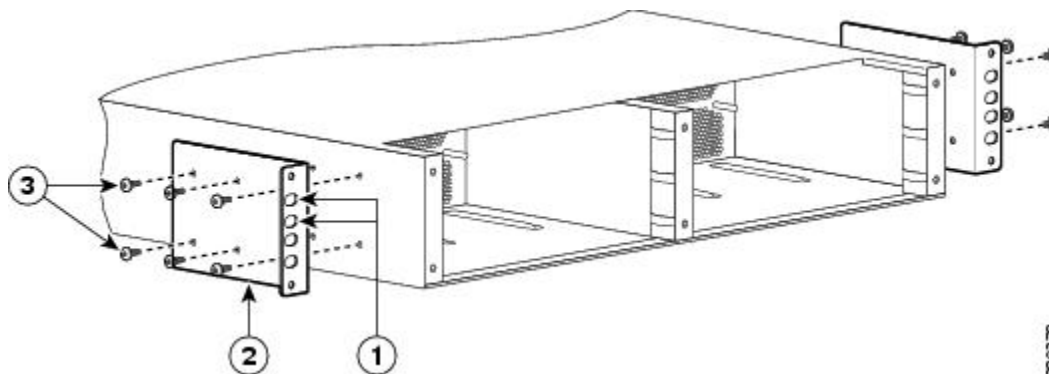

1	Rear rack-mount bracket ear and holes	3	Rear rack-mount bracket screws
2	Rear rack-mount bracket	—	—

Step 2 Position the rear rack-mount bracket top hole with the chassis top hole from the back.

Step 3 Insert and tighten the screws on one side.

Step 4 Repeat Step 1 through Step 3 on the other side of the chassis. Use the remaining screws to secure the rear rack-mount brackets to the chassis.

What to do next

This completes the steps for attaching the rear rack-mount brackets to the Cisco ASR 1002 Router.



Caution To make installation easier, before you mount the ASR 1002 Router in a rack, make certain you read which rack-mount bracket ear holes to use when positioning the chassis in the rack. As a result of using the designated ear holes on the rack-mount bracket, the cable-management bracket installation will be made easier.

Installing the Cisco ASR 1002 Router in a Rack

After installing the rack-mount brackets on the chassis, you mount the chassis by securing the rack-mount brackets to two posts or mounting strips in the rack using the screws provided. Because the rack-mount brackets support the weight of the entire chassis, be sure to use all screws to fasten the two rack-mount brackets to the rack posts.

**Warning**

To prevent bodily injury when mounting or servicing this unit in a rack, you must take special precautions to ensure that the system remains stable. The following guidelines are provided to ensure your safety:-This unit should be mounted at the bottom of the rack if it is the only unit in the rack.-When mounting this unit in a partially filled rack, load the rack from the bottom to the top with the heaviest component at the bottom of the rack.-If the rack is provided with stabilizing devices, install the stabilizers before mounting or servicing the unit in the rack. Statement 1006

We recommend that you allow at least 1 or 2 inches (2.54 or 5.08 cm) of vertical clearance between the router and any equipment directly above and below it.

To install the chassis in the rack, perform the following steps:

SUMMARY STEPS

1. On the chassis, ensure that all screw fasteners on the installed components are securely tightened.
2. Make sure that your path to the rack is unobstructed. If the rack is on wheels, ensure that the brakes are engaged or that the rack is otherwise stabilized. See the next sections on the types of racks you can use to install the chassis.
3. (Optional) Install a shelf in the rack to support the Cisco ASR 1002 Router. If you use a shelf, this will help support the chassis while you secure it to the rack.
4. With two people, lift the chassis into position between the rack posts.
5. Align the mounting bracket holes with the rack post holes and attach the chassis to the rack.
6. Position the chassis until the rack-mounting flanges are flush against the mounting rails on the rack.
7. Hold the chassis in position against the mounting rails in the equipment rack and follow these steps:
8. Tighten all screws on each side to secure the chassis to the equipment rack.

DETAILED STEPS

-
- Step 1** On the chassis, ensure that all screw fasteners on the installed components are securely tightened.
- Step 2** Make sure that your path to the rack is unobstructed. If the rack is on wheels, ensure that the brakes are engaged or that the rack is otherwise stabilized. See the next sections on the types of racks you can use to install the chassis.
- Step 3** (Optional) Install a shelf in the rack to support the Cisco ASR 1002 Router. If you use a shelf, this will help support the chassis while you secure it to the rack.
- Step 4** With two people, lift the chassis into position between the rack posts.
- Step 5** Align the mounting bracket holes with the rack post holes and attach the chassis to the rack.
- Note** If you are using a shelf then raise the chassis to the level of the shelf. Let the bottom of the chassis rest on the brackets, but continue to support the chassis.

Step 6 Position the chassis until the rack-mounting flanges are flush against the mounting rails on the rack.

Tip To allow space to attach the cable-management brackets to the chassis in the rack easily, make certain that you use the rack-mount bracket ear holes specified in the next steps.

Step 7 Hold the chassis in position against the mounting rails in the equipment rack and follow these steps:

a) Insert the bottom screw into the second hole up from the bottom of the rack-mount ear and use a hand-held screwdriver to tighten the screw to the rack rail.

Tip To make installation easier, insert one screw at the bottom of the chassis and the next screw at the top of the chassis diagonally from the first screw.

b) Insert the top screw into the second hole from the top of the rack-mount ear diagonally from the bottom screw and tighten the screw to the rack rail.

c) Insert the four screws to secure the chassis to the rack equipment.

Tip As a result of using the specified rack-mount bracket ear holes, the cable-management bracket can be easily attached to the rack-mount bracket when the chassis is in the rack.

Step 8 Tighten all screws on each side to secure the chassis to the equipment rack.

Two-Post Rack Installation

The Cisco ASR 1002 Router can be installed on a two-post rack, either 19 inch or 23 inch.



Note Inner clearance (the width between the inner sides of the two posts or rails) must be at least 19 inches (48.26 cm). The height of the chassis is 3.47 inches (8.8 cm). Airflow through the chassis is from front to back.



Caution If you are using a two-post rack secure the rack to the floor surface to prevent tipping and avoid bodily injury and component damage.

SUMMARY STEPS

1. Position the chassis so the front is closest to you and lift it carefully into the rack. To prevent injury, avoid any sudden twists or moves.
2. Slide the chassis into the rack, pushing it back until the brackets meet the mounting strips or posts on both sides of the rack.
3. Keeping the brackets flush against the posts or mounting strips, align the holes in the brackets with the holes on the rack or mounting strip.
4. For each bracket, insert and tighten two screws to the rack on both sides.

DETAILED STEPS

Step 1 Position the chassis so the front is closest to you and lift it carefully into the rack. To prevent injury, avoid any sudden twists or moves.

The following image shows where to attach the rear rack-mount brackets to the Cisco ASR 1002 Router.

Figure 14: Attaching the Rear Rack-Mount Brackets to the Cisco ASR 1002 Router

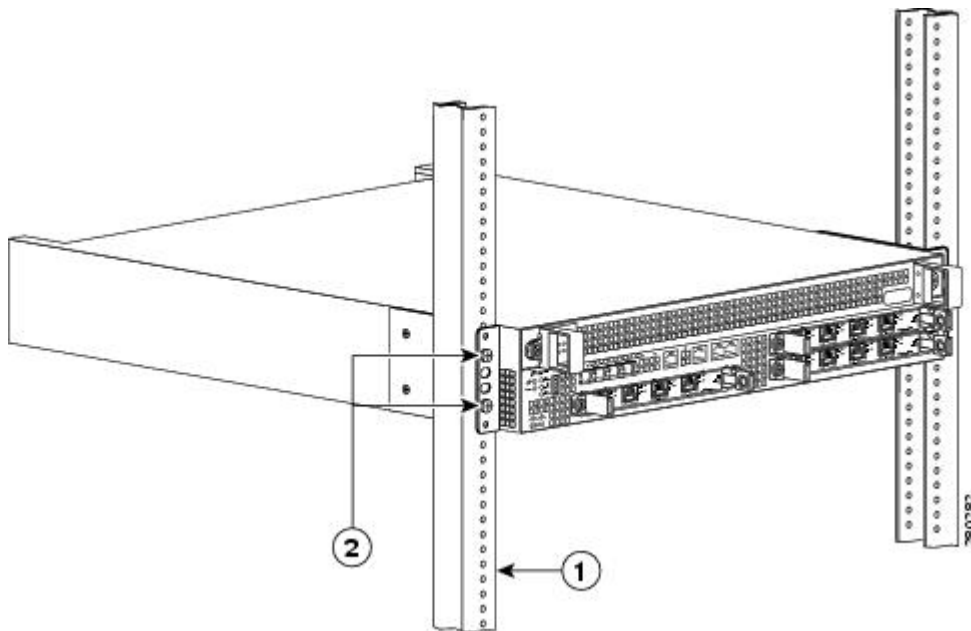

1	Rack equipment rail	2	Rack-mount bracket ear and holes
---	---------------------	---	----------------------------------

Step 2 Slide the chassis into the rack, pushing it back until the brackets meet the mounting strips or posts on both sides of the rack.

Step 3 Keeping the brackets flush against the posts or mounting strips, align the holes in the brackets with the holes on the rack or mounting strip.

Step 4 For each bracket, insert and tighten two screws to the rack on both sides.

This completes the procedure for installing the chassis on a two-post rack. Proceed to the [Attaching a Chassis Ground Connection](#), on page 27 to continue the installation.

Four-Post Rack Installation

The Cisco ASR 1002 Router can be flush-mounted in a 19-inch equipment rack using the rack-mounting kit provided with your system. The Cisco ASR 1002 Router can be mounted into the rack using two recommended methods:

- Installing the chassis in an existing rack with equipment.
- Installing an empty chassis in a rack with no equipment installed.

When handling the chassis, always follow proper lifting practices. See the Chassis-Lifting Guidelines” section on page 5-23 .



Note Inner clearance (the width between the inner sides of the two posts or rails) must be at least 19 inches (48.26 cm). The height of the chassis is 3.47 inches (8.8 cm). Airflow through the chassis is from front to back.



Note Make sure the rack is stabilized.

SUMMARY STEPS

1. (Optional) Install a shelf in the rack to support the Cisco ASR 1002 Router. If you are using a shelf then raise the chassis to the level of the shelf. Let the bottom of the chassis rest on the brackets, but continue to support the chassis. Using two people, lift the chassis into the rack using the side handles and grasping underneath the power supply bays.
2. Position the chassis until the rack-mounting flanges are flush against the mounting rails on the rack.
3. Hold the chassis in position against the mounting rails while the second person finger-tightens a screw to the rack rails on each side of the chassis.
4. Finger-tighten screws to the rack rails on each side of the chassis.
5. Tighten all screws on each side to secure the chassis to the equipment rack (see the following image).
6. Use a level to verify that the tops of the two brackets are level, or use a measuring tape to verify that both brackets are the same distance from the top of the rack rails.

DETAILED STEPS

-
- Step 1** (Optional) Install a shelf in the rack to support the Cisco ASR 1002 Router. If you are using a shelf then raise the chassis to the level of the shelf. Let the bottom of the chassis rest on the brackets, but continue to support the chassis. Using two people, lift the chassis into the rack using the side handles and grasping underneath the power supply bays.
- Step 2** Position the chassis until the rack-mounting flanges are flush against the mounting rails on the rack.
- Note** Use the second hole up from the bottom of the rack-mount bracket and the second hole down from the top of the rack-mount bracket. This will make it easier to attach the cable-management bracket to the chassis in the equipment rack.
- Step 3** Hold the chassis in position against the mounting rails while the second person finger-tightens a screw to the rack rails on each side of the chassis.
- Step 4** Finger-tighten screws to the rack rails on each side of the chassis.
- Step 5** Tighten all screws on each side to secure the chassis to the equipment rack (see the following image).

Figure 15: Cisco ASR 1002 Router on a Four-Post Rack—Front and Rear Rack-Mounting

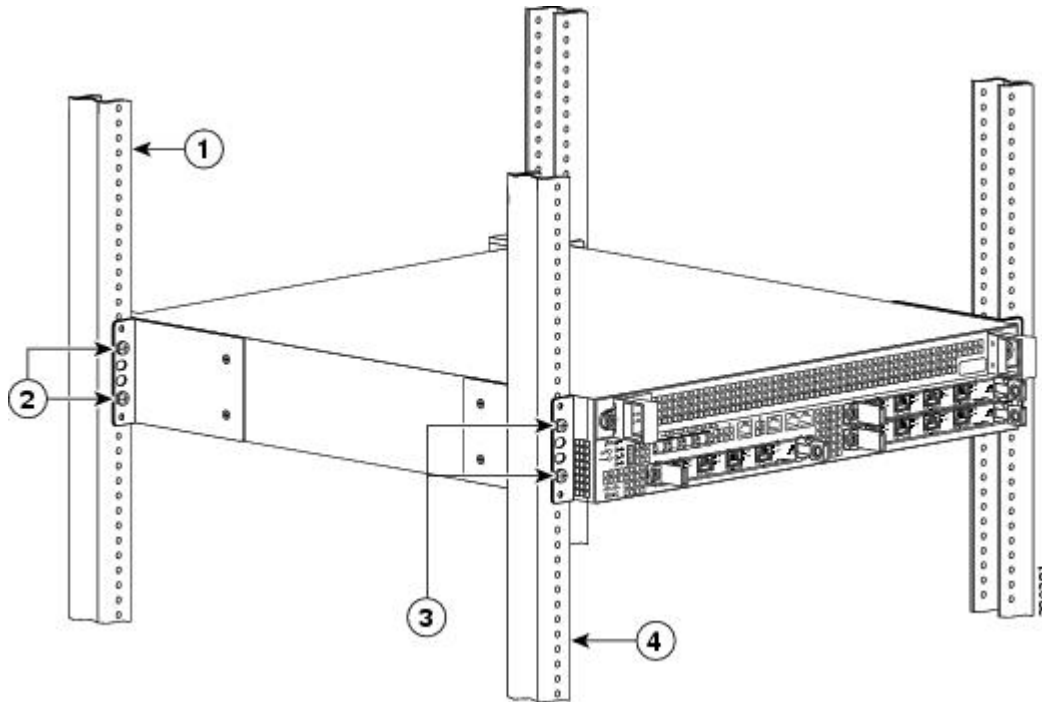

1	Rear rack equipment rail	3	Front rack-mount bracket ear and holes
2	Rear rack-mount bracket ear and holes	4	Front rack equipment rail

Step 6 Use a level to verify that the tops of the two brackets are level, or use a measuring tape to verify that both brackets are the same distance from the top of the rack rails.

What to do next

This completes the procedure for installing the chassis in the rack. Proceed to the [Attaching the Cable-Management Bracket, on page 25](#) to continue the installation.

Attaching the Cable-Management Bracket

The cable-management brackets mount to each rack-mount bracket on the chassis to provide cable-management to both sides of the chassis (parallel with card orientation). These brackets are screw mounted to the rack-mount brackets to allow easy installation and removal of cables.

The cable-management brackets for the Cisco ASR 1002 Router contain one independent cable-management “U” type features with four screws and provides cable dressing of each card module slot.



Note Make certain that the cable-management bracket “U” type feature is facing upwards when you attach it to the chassis.

Follow these steps to attach the cable-management brackets to both sides of the Cisco ASR 1002 Router in the rack:

SUMMARY STEPS

1. Align the cable-management bracket to the rack-mount bracket on one side of the Cisco ASR 1002 Router. The cable-management bracket aligns to the top hole of the chassis rack-mount bracket.
2. Using a Phillips screwdriver, insert the screw through cable-management bracket and into the chassis rack-mount and tighten the screw.
3. Using the bottom rack-mount ear hole, insert the screw through cable-management bracket and into the chassis rack-mount (see [Attaching the Cable-Management Bracket, on page 25](#)).

DETAILED STEPS

Step 1 Align the cable-management bracket to the rack-mount bracket on one side of the Cisco ASR 1002 Router. The cable-management bracket aligns to the top hole of the chassis rack-mount bracket.

Step 2 Using a Phillips screwdriver, insert the screw through cable-management bracket and into the chassis rack-mount and tighten the screw.

Note Use the package of four screws.

The following image shows the locations at which to attach the front rack-mount brackets to the Cisco ASR 1002 Router in a rack.

Figure 16: Chassis Rack-Mount Bracket Ear Holes for the Cable-Management Brackets

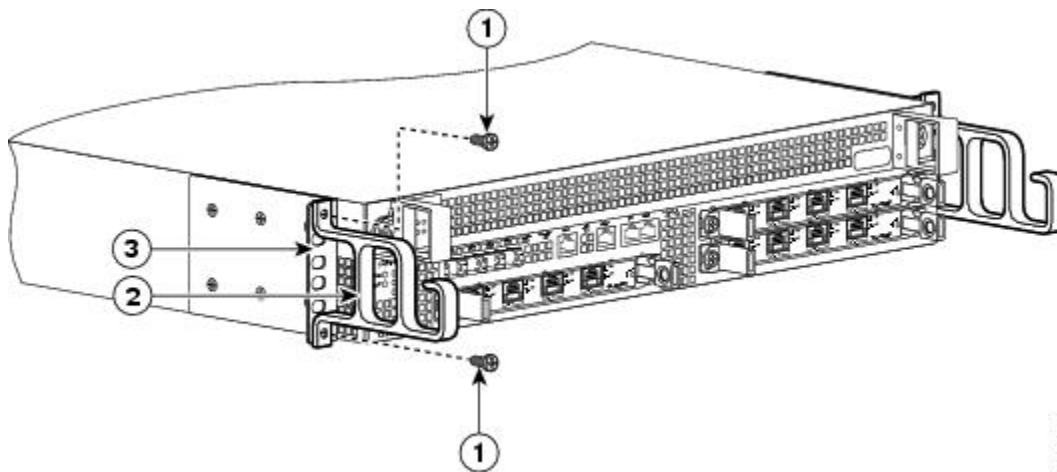

1	Secure the cable-management top screw and bottom to this ear hole	3	Front rack-mount bracket
2	Cable-management bracket		

Step 3 Using the bottom rack-mount ear hole, insert the screw through cable-management bracket and into the chassis rack-mount (see [Attaching the Cable-Management Bracket, on page 25](#)).

What to do next

This completes the procedure for installing the cable-management brackets on the chassis.

Attaching a Chassis Ground Connection

Connecting the Cisco ASR 1002 chassis to ground is required for all DC powered installations and any AC powered installation where compliance with Telcordia grounding requirements is necessary.



Caution The dual-lug chassis ground stud must be installed, all cards or filler plates must be fully inserted and screwed in and earthed to prevent a potential hazard in a telecom line.

Have the recommended tools and supplies available before you begin this procedure.



Warning This equipment must be grounded. Never defeat the ground conductor or operate the equipment in the absence of a suitably installed ground conductor. Contact the appropriate electrical inspection authority or an electrician if you are uncertain that suitable grounding is available. Statement 1024

Before you connect power or turn on power to your chassis, you must provide an adequate chassis ground (earth) connection for the chassis. The chassis ground lug (two) and the respective screws (four) are provided in the accessory kit that ships with your Cisco ASR 1002 Router.



Caution The grounding wire is always the first to be installed or connected and the last to be removed or disconnected.

The following tools, equipment, and supplies necessary to connect the system ground to the chassis:

- Phillips screwdriver
- Dual-lug chassis ground component (two) and respective screws (four) (shipped with the accessory kit)
- Grounding wire

The following image shows the location of the dual ground lug on the side of the of Cisco ASR 1002 Router.

Figure 17: Cisco ASR 1002 Router Chassis Ground Lug Location and Side Panel Door

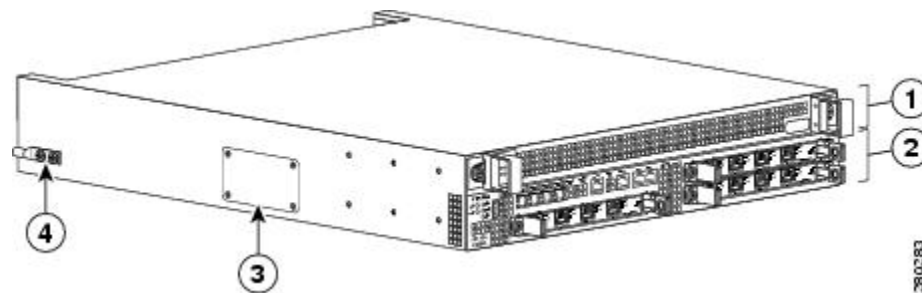

1	F0 with ASR1000-ESP5 or ESP10.	3	The eUSB panel door on the side of the Cisco ASR 1002 Router must not be opened. If there is a problem with eUSB flash card, the chassis should be returned.
2	R0 slot with embedded ASR1000-RP1 and embedded ASR1000-SIP10.	4	Cisco ASR 1002 Router ground stud location.

To attach the grounding lug to the chassis ground connector on your chassis, follow these steps:

SUMMARY STEPS

1. Use the wire stripper to strip one end of the AWG #6 wire approximately 0.75 inches (19.05 mm).
2. Insert the AWG #6 wire into the wire receptacle on the grounding lug. Use the manufacturer's recommended crimping tool to carefully crimp the wire receptacle around the wire; this step is required to ensure a proper mechanical connection.
3. Attach the grounding lug with the wire on the left to avoid having the grounding wire overlapping the power supply.
4. Locate the chassis ground connector on the side of your chassis.
5. The following image shows how to attach the grounding lug to the chassis ground connector.
6. Insert the two screws through the holes in the grounding lug.
7. Use the Number 2 Phillips screwdriver to carefully tighten the screws until the grounding lug is held firmly to the chassis. Do not overtighten the screws.
8. Connect the opposite end of the grounding wire to the appropriate grounding point at your site to ensure an adequate chassis ground.

DETAILED STEPS

Step 1 Use the wire stripper to strip one end of the AWG #6 wire approximately 0.75 inches (19.05 mm).

Step 2 Insert the AWG #6 wire into the wire receptacle on the grounding lug. Use the manufacturer's recommended crimping tool to carefully crimp the wire receptacle around the wire; this step is required to ensure a proper mechanical connection.

The following image shows the parts of the grounding lug.

Figure 18: Parts of the Grounding Lug

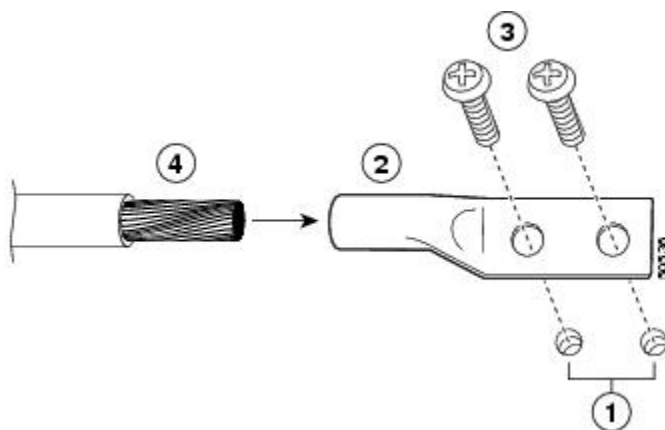

1	Chassis ground connector holes	3	Ground lug screws
---	--------------------------------	---	-------------------

2	Grounding lug	4	Ground wire
---	---------------	---	-------------

Step 3 Attach the grounding lug with the wire on the left to avoid having the grounding wire overlapping the power supply.

Step 4 Locate the chassis ground connector on the side of your chassis.

Step 5 The following image shows how to attach the grounding lug to the chassis ground connector.

Figure 19: Attaching a Grounding Lug to the Chassis Ground Connector

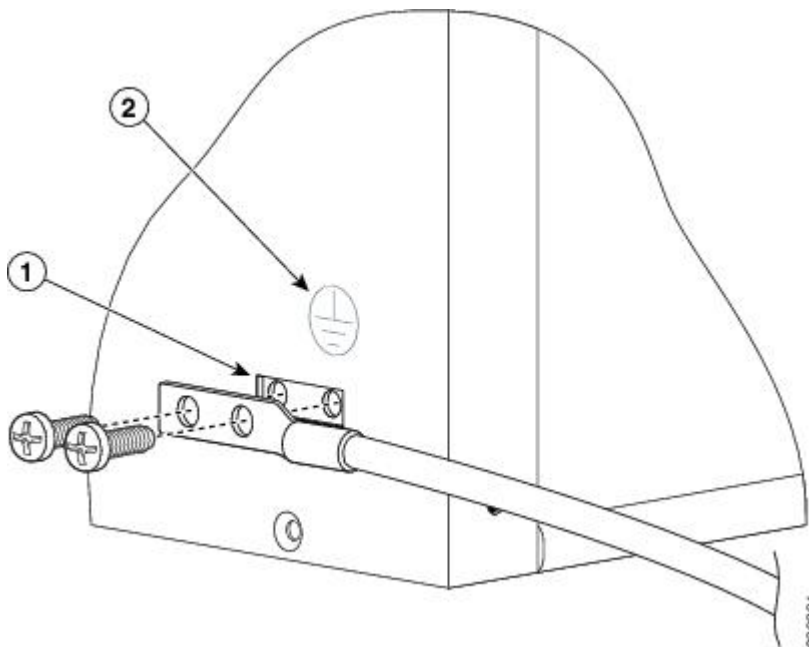

1	Chassis ground connector	2	Ground symbol
---	--------------------------	---	---------------

Step 6 Insert the two screws through the holes in the grounding lug.

Step 7 Use the Number 2 Phillips screwdriver to carefully tighten the screws until the grounding lug is held firmly to the chassis. Do not overtighten the screws.

Step 8 Connect the opposite end of the grounding wire to the appropriate grounding point at your site to ensure an adequate chassis ground.

What to do next

This completes the procedure for attaching a chassis ground connection. Go to the following cabling sections for information on attaching cables.

Connecting the Shared Port Adapter Cables

The instructions for connecting the cables for the shared port adapter installed in the Cisco ASR 1002 Router are contained in the respective configuration documents for each port adapter. For example, if you are

connecting the optical fiber cables for the PA-POS-OC3 port adapter, see PA-POS-OC3 Port Adapter Installation and Configuration at the following location:

http://www.cisco.com/en/US/partner/docs/interfaces_modules/port_adapters/install_upgrade/pos/pa-pos-oc3_install_config/paposoc3.html

Connecting the Console and Auxiliary Port Cables

This section describes how to attach a cable to the Cisco embedded ASR1000-RP1 console or auxiliary ports on the Cisco ASR 1002 Router. The Cisco ASR 1002 Router uses RJ-45 ports for both the auxiliary port and console port.



Caution To meet Class A emission requirements, shielded cables must be used for the console and auxiliary port connectors.

Before you can use the console interface on the router using a terminal or PC, you must perform the following steps:

SUMMARY STEPS

1. Before connecting a terminal to the console port, configure the terminal to match the chassis console port as follows: 9600 baud, 8 data bits, no parity, 1 stop bits (9600 8N1).
2. Connect to the port using the RJ-45 to DB-9 cable.
3. After you establish normal router operation, you can disconnect the terminal.

DETAILED STEPS

Step 1 Before connecting a terminal to the console port, configure the terminal to match the chassis console port as follows: 9600 baud, 8 data bits, no parity, 1 stop bits (9600 8N1).

Step 2 Connect to the port using the RJ-45 to DB-9 cable.

Note For information about how to change the default settings to meet the requirements of your terminal or host, see [Cisco IOS Terminal Services Configuration Guide](#).

The following shows the Cisco ASR 1002 Router embedded ASR1000-RP1 console and auxiliary port connectors.

Figure 20: Cisco ASR 1002 Router Embedded ASR1000-RP1 Console and Auxiliary Port Connectors

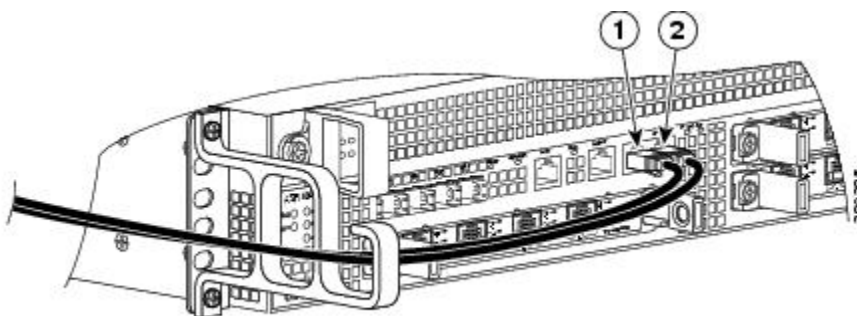

1	CON—console port	2	AUX—auxiliary port
---	------------------	---	--------------------

Step 3 After you establish normal router operation, you can disconnect the terminal.

What to do next



Note A connection will not be established when setting up an out-of-band connection or modem connection in the auxiliary port and the console port.

Management Ethernet Port Cable Connection



Caution To comply with Class A emissions requirements, a shielded Ethernet cable must be used for the connection.

To use the Management Ethernet interface on the router, perform the following steps:

SUMMARY STEPS

1. Insert an Ethernet RJ-45 cable into the MGMT ETHERNET port (see the following image.).
2. Insert the other end of the RJ-45 cable to your management device or network.

DETAILED STEPS

Step 1 Insert an Ethernet RJ-45 cable into the MGMT ETHERNET port (see the following image.).

Figure 21: Cisco ASR 1002 Router Embedded ASR1000-RP1 Management Port Connector

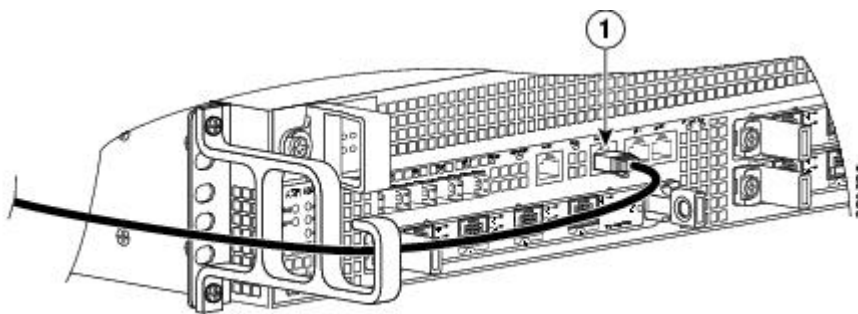

1	MGMT - management port and cable
---	----------------------------------

Step 2 Insert the other end of the RJ-45 cable to your management device or network.

Cisco ASR 1002 Router Power Supplies

This section describes the Cisco ASR 1002 Router power supplies and how to connect them:

Read the safety warnings before you begin.



Warning The covers are an integral part of the safety design of the product. Do not operate the unit without the covers installed. Statement 1077



Warning When you install the unit, the ground connection must always be made first and disconnected last. Statement 1046



Warning Before performing any of the following procedures, ensure that power is removed from the DC circuit. Statement 1003



Warning Only trained and qualified personnel should be allowed to install, replace, or service this equipment. Statement 1030



Warning Never install an AC power module and a DC power module in the same chassis. Statement 1050



Warning Installation of the equipment must comply with local and national electrical codes. Statement 1074



Warning When installing or replacing the unit, the ground connection must always be made first and disconnected last. Statement 1046



Warning This equipment must be grounded. Never defeat the ground conductor or operate the equipment in the absence of a suitably installed ground conductor. Contact the appropriate electrical inspection authority or an electrician if you are uncertain that suitable grounding is available. Statement 1024



Warning This unit has two power supply connections. All connections must be removed to de-energize the unit. Statement 1028

**Warning**

This product relies on the building's installation for short-circuit (overcurrent) protection. Ensure that the protective device is rated not greater than: AC power supplies 20 A and DC power supplies 30 A. Statement 1005

This section provides the procedures for connecting AC-input, -48 VDC input power, and the +24 VDC input power to your Cisco ASR 1002 Router.

**Note**

Detailed instructions for removing and replacing the Cisco ASR 1002 Router AC and DC power supplies are in Chapter 14, "Removing and Replacing FRUs from the Cisco ASR 1000 Series Routers."

Connecting AC Input Power to Cisco ASR 1002 Router

To connect AC power to the Cisco ASR 1002 Router, follow these steps:

SUMMARY STEPS

1. At the rear of the router, check that the power switch is in the Off (O) position.
2. Insert the AC power cable into the power supply AC inlet.
3. To ensure that the AC power cord does not interfere with other cables or wires, dress the AC power cable in one of the following ways.
4. Plug the AC power supply cable into the AC power source.

DETAILED STEPS

Step 1 At the rear of the router, check that the power switch is in the Off (O) position.

Note Turn the power switch to the On (I) position after both sides of the power cord are connected.

The following shows the various parts of the Cisco ASR 1002 Router AC power supply.

Figure 22: Cisco ASR 1002 Router AC Power Supply Labels

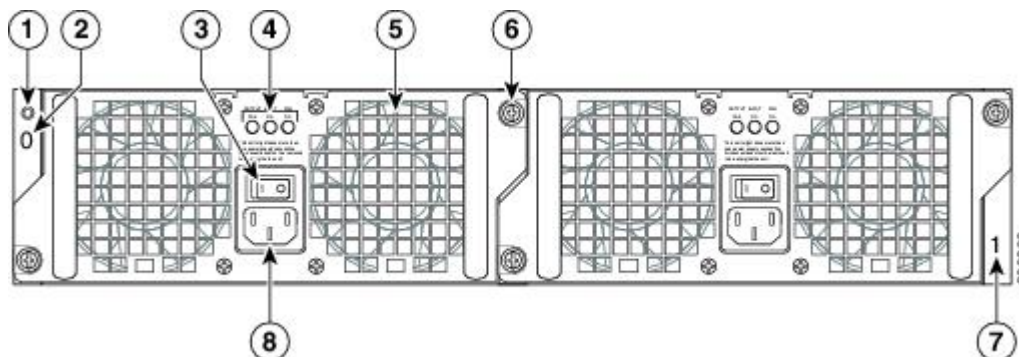

1	Chassis ESD socket	5	AC power supply fan
2	AC power supply slot number 0	6	AC power supply captive installation screw

3	AC power supply On (I) /Off (O) switch	7	AC power supply slot number 1
4	AC power supply LEDs	8	AC power inlet

Step 2 Insert the AC power cable into the power supply AC inlet.

Step 3 To ensure that the AC power cord does not interfere with other cables or wires, dress the AC power cord in one of the following ways.

- a) Leave a small service loop in the AC power cord from the inlet and then secure the power cord through the AC power supply handle as shown in the Connecting AC Input Power to Cisco ASR 1002 router image. Alternatively, proceed to Step b.

Figure 23: Positioning Cisco ASR 1002 Router AC Power Supply and Cord in Slot 1

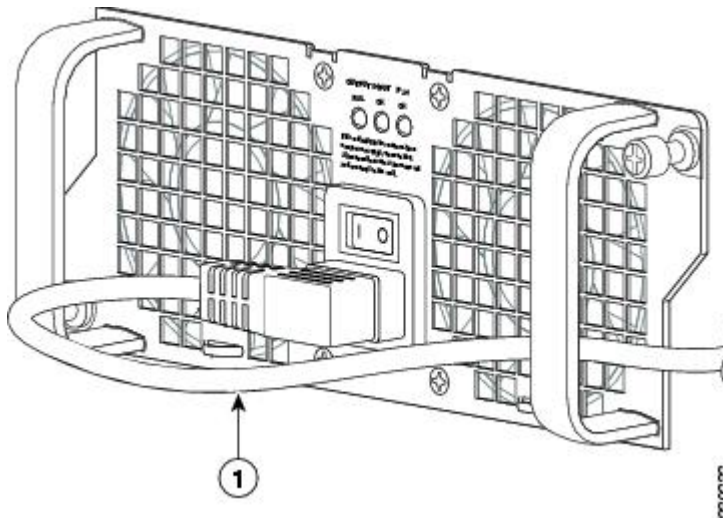

1	AC power cord
---	---------------

- b) Take the power cord and run it below the handles of the right and left power supplies. Make sure the power cord is hanging loose so that it will not be disconnected from the AC power inlet as shown in the following image.

Figure 24: Cisco ASR 1002 Router AC Power Supply in Slot 0 and Slot 1 With Power Cord

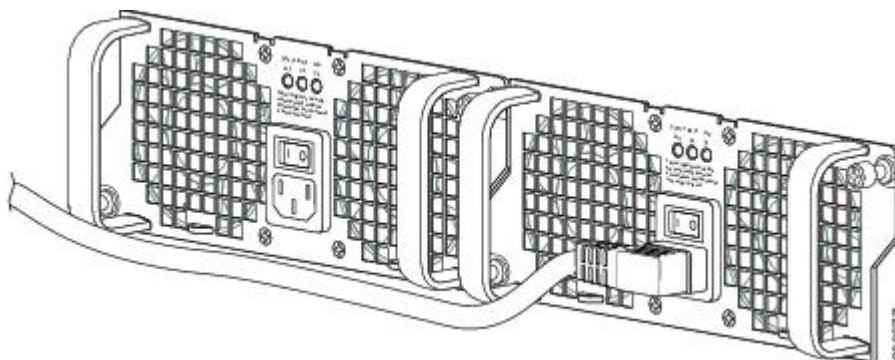

Caution Do not run the AC power cord through the power supply handles as shown in Connecting AC Input Power to Cisco ASR 1002 router image.

Figure 25: Incorrect Cabling on Cisco ASR 1002 Router AC Power Supply

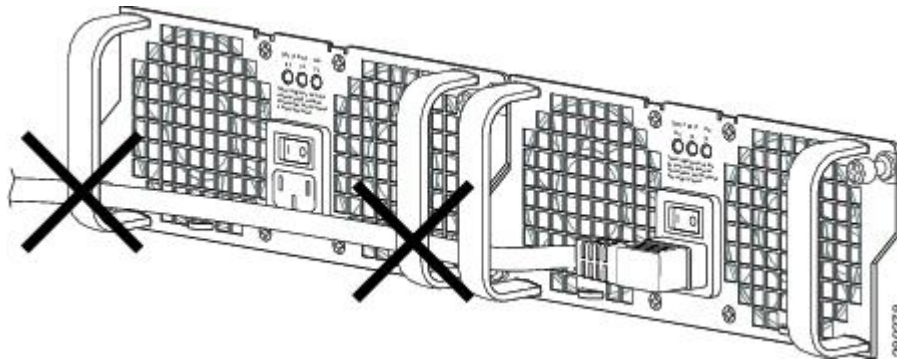

Note Using a tie wrap for the AC power cable is optional and not necessary. However, if you do attach the AC power cable to a power supply tab and then you remove the AC power cable for some reason, check for any damage to the cable after you cut the tie wrap off. If the power cord is damaged, replace it immediately.

Step 4 Plug the AC power supply cable into the AC power source.

What to do next

This completes the procedure for connecting an AC power supply in the Cisco ASR 1002 Router.

Connecting 48 VDC Input Power to Cisco ASR 1002 Router

The –48 VDC power supply input connector is a Euro-style terminal block. A means to provide strain relief to the input wires is provided on the power supply. The connection order is negative (–), positive (+), and GND; but this is the order from left to right that the terminals appear on the power supply, not the order in which the leads should be connected during installation. The order the leads should be attached is GND, positive (+), and negative (–).

The recommended branch circuit breaker for the Cisco ASR 1002 Router –48 VDC power supply is 30 A. Use a AWG #10 wire gauge on the 30 A circuit.

The following image shows the –48 VDC power supply for the Cisco ASR 1002 Router.

Figure 26: –48 VDC Power Supply for the Cisco ASR 1002 Router

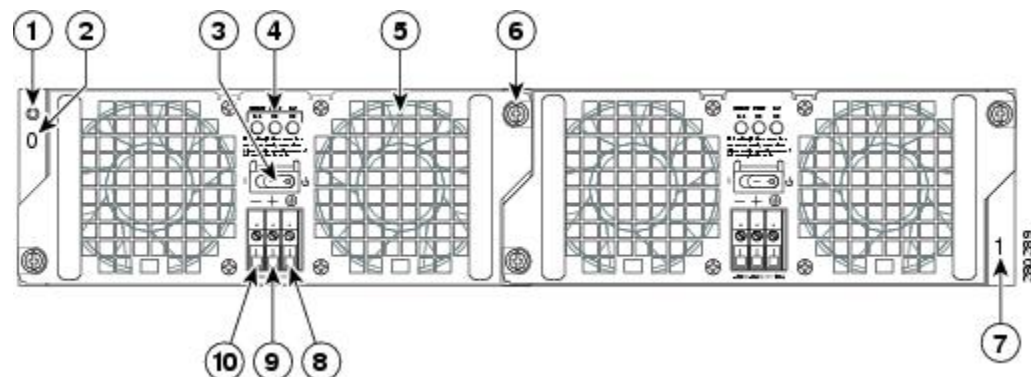

1	Chassis ESD socket	6	-48 VDC power supply captive installation screw
2	-48 VDC power supply slot 0 label	7	-48 VDC power supply slot 1 label
3	-48 VDC power supply switch Standby/On	8	Ground lead
4	-48 VDC power supply LEDs	9	Positive lead
5	Fan	10	Negative lead

Table 10: Cisco ASR 1002 Router -48 VDC Power Supply LEDs, on page 36 describes the LEDs on the Cisco ASR 1002 Router -48 VDC power supply.

Table 10: Cisco ASR 1002 Router -48 VDC Power Supply LEDs

LED Label	LED	Color	Description
INPUT OK	A bi-color LED indicates presence of input voltage	Green	LED illuminates green to signal that the -48 VDC power supply input voltage is greater than 43.5VDC at turn-on and remains green down to 39VDC.
		Amber	The LED illuminates amber if the power supply turns off due to low input voltage (falls below 39VDC) and indicates that there is still a hazard present (voltage on the terminal block). The LED remains amber and is active to around 20 V +/-5 V. The LED is not illuminated if the input is below 15 V.
FAN OK	A bi-color LED indicates power supply fan status	Green	The LED illuminates green when all fans are operational.
		Red	The LED illuminates red when a fan failure is detected.
OUTPUT FAIL	Power supply activity	Red	When the LED is off, it signals that the -48 VDC output voltage are within the normal operating range. Output voltage between the minimum and maximum limits will not create an output fail alarm, and output voltages below the minimum or above the maximum will create an Output Fail alarm. Led illuminates red to indicate that the -48 VDC output is out of the specified range. When you turn the power supply on, the red LED illuminates for two to three seconds to test LED operation before going off.

This section describes how to connect the -48 VDC power supply in the Cisco ASR 1002 Router.



Note The color coding of the -48 VDC input power supply leads depends on the color coding of the -48 VDC power source at your site. Typically, green or green/yellow is used for ground. Make certain the lead color coding you choose for the -48 VDC input power supply matches lead color coding used at the -48 VDC power source.



Warning When you install the unit, the ground connection must always be made first and disconnected last. Statement 1046

SUMMARY STEPS

1. At the rear of the router, check that the power supply Standby switch is in the Standby (see [Figure 27: Cisco ASR 1002 Router –48 VDC Power Supply Terminal Block Cable Connections, on page 37](#)) position.
2. Ensure that the negative and positive leads are disconnected from the site power source.
3. Using a wire stripper, strip approximately 0.55 inch (14 mm) from the negative, positive, and ground lead.
4. Insert the stripped end of the ground lead all the way into the ground lead receptacle on the –48 VDC input power supply, and tighten the receptacle screw using a 3.5mm flat-blade screwdriver to a torque of 0.5 to 0.6Nm.
5. Insert the stripped end of the positive lead all the way into the positive lead receptacle and tighten the receptacle screw using the same 3.5mm flat-blade screwdriver. Repeat this step for the negative lead.
6. After tightening the receptacle screw for the ground, positive, and negative –48 VDC-input leads, use a cable tie to secure the three leads to the power supply faceplate, as shown in the image. When securing the ground, positive, and negative –48 VDC-input leads to the power supply faceplate, leave a small service loop in the ground lead to ensure that the ground lead is the last lead to disconnect from the power supply if a great deal of strain is placed on all three leads as shown in the image.
7. Connect the ground, positive, and negative leads to the power source.
8. Turn the branch source breaker on.
9. Place the –48 VDC Standby switch in the On (I) position. The power supply LEDs light when power is supplied to the router.

DETAILED STEPS

Step 1

At the rear of the router, check that the power supply Standby switch is in the Standby (see [Figure 27: Cisco ASR 1002 Router –48 VDC Power Supply Terminal Block Cable Connections, on page 37](#)) position.

Figure 27: Cisco ASR 1002 Router –48 VDC Power Supply Terminal Block Cable Connections

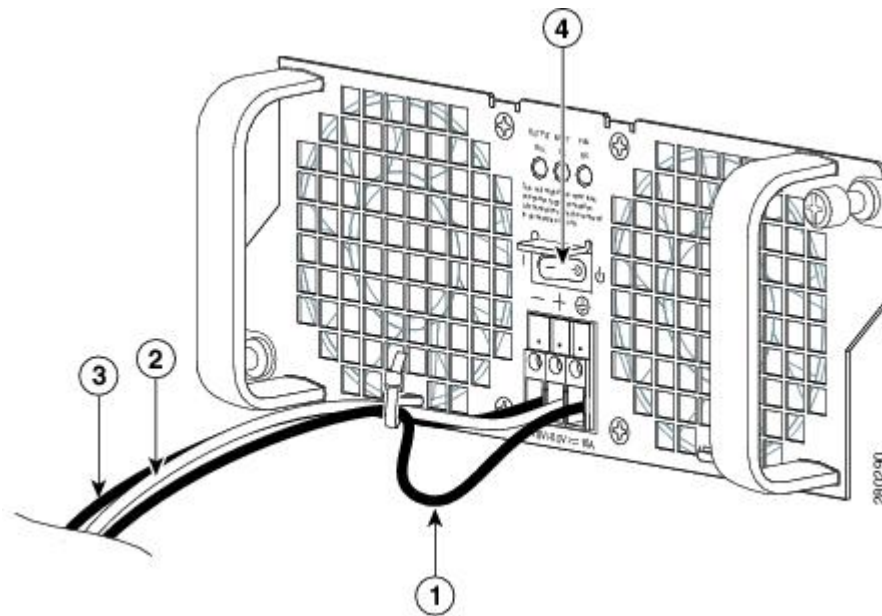

1	Ground lead with service loop and tie-wrap	3	Negative lead
---	--	---	---------------

2	Positive lead	4	-48 VDC power supply Standby switch
---	---------------	---	-------------------------------------

- Step 2** Ensure that the negative and positive leads are disconnected from the site power source.
- Step 3** Using a wire stripper, strip approximately 0.55 inch (14 mm) from the negative, positive, and ground lead.
- Step 4** Insert the stripped end of the ground lead all the way into the ground lead receptacle on the -48 VDC input power supply, and tighten the receptacle screw using a 3.5mm flat-blade screwdriver to a torque of 0.5 to 0.6Nm.
- Step 5** Insert the stripped end of the positive lead all the way into the positive lead receptacle and tighten the receptacle screw using the same 3.5mm flat-blade screwdriver. Repeat this step for the negative lead.
- Note** Make sure the entire stripped end of each lead is inserted all the way into its receptacle. If any exposed wire at the stripped end of a lead is visible after inserting the lead into its receptacle, remove the lead from the receptacle, use the wire stripper to cut the stripped end of the lead, and repeat Step 3 through Step 5.
- Step 6** After tightening the receptacle screw for the ground, positive, and negative -48 VDC-input leads, use a cable tie to secure the three leads to the power supply faceplate, as shown in the image. When securing the ground, positive, and negative -48 VDC-input leads to the power supply faceplate, leave a small service loop in the ground lead to ensure that the ground lead is the last lead to disconnect from the power supply if a great deal of strain is placed on all three leads as shown in the image.
- Caution** Make certain that the ground lead wire has a service loop before you tie wrap the lead wires to prevent the ground from being disconnected.
- Step 7** Connect the ground, positive, and negative leads to the power source.
- Step 8** Turn the branch source breaker on.
- Step 9** Place the -48 VDC Standby switch in the On (I) position. The power supply LEDs light when power is supplied to the router.

What to do next

You have completed the procedure for connecting a -48 VDC power supply in the Cisco ASR 1002 Router.

Connecting Cisco 24 VDC Power Supply

The +24 VDC power supply uses a spring-loaded terminal block. The input terminal block requires 8 AWG multi-strand wiring to support input current. Features are provide for strain relieving the input wires from the terminal block on the front panel. The recommended branch circuit breaker for the Cisco ASR 1002 Router +24 VDC power supply is a 40 A UL listed circuit breaker.

Before you begin, read these important notices about the +24 VDC power supply:

- The labeling displays +27 VDC INPUT. This labeling describes the nominal voltage provided at a cell site.
- Observe the polarity location—Unlike the polarity labels of the -48 VDC power supply (ground, positive, negative), the polarity labels on the +24 VDC are ground, negative, positive as shown from right to left as they appear on the actual power supply unit.
- The ground (GND) lead is always installed first and removed last.
- The +24 VDC power supply uses a spring loaded terminal block; therefore have the recommended screwdriver size available.

- Review the diagrams to see how the wire is stripped and how the screwdriver is inserted at an angle into the terminal block.
- Have the following equipment available to install and remove the +24 VDC power supply:
 - Phoenix Contact 3.5mm flat-blade screwdriver or equivalent
 - Wire-stripping tool for stripping 8-gauge wire

The following image shows the +24 VDC power supply for the Cisco ASR 1002 Router.

Figure 28: +24 VDC Power Supply for the Cisco ASR 1002 Router Components

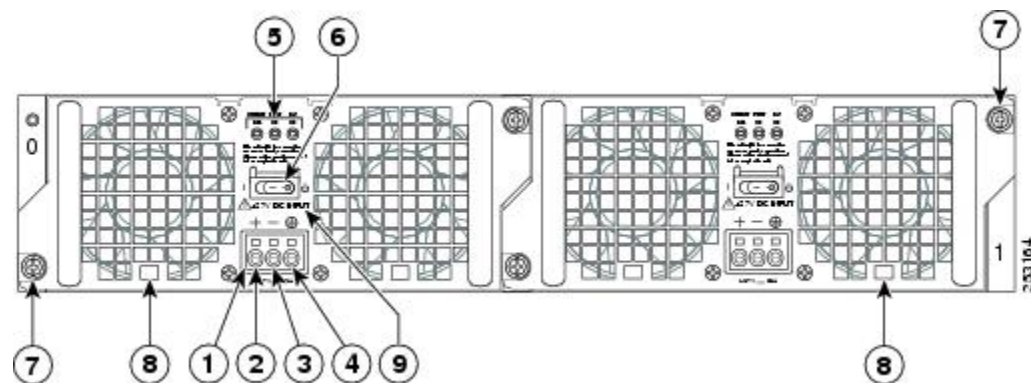

1	+24 VDC terminal block	6	Standby/On switch
2	Positive (+) lead	7	Captive fastener
3	Negative (-) lead	8	Power supply tabs
4	Ground (GND) lead	9	+27 VDC INPUT label
5	Power supply LEDs	—	—

This section describes how to connect the +24 VDC power supply in the Cisco ASR 1002 Router.



Note The color coding of the +24 VDC input power supply leads depends on the color coding of the +24 VDC power source at your site. Typically, green or green/yellow is used for ground. Make certain the lead color coding you choose for the +24 VDC input power supply matches lead color coding used at the +24 VDC power source. Most commonly used wire color-coding is red for positive (+) lead and black for negative (-) lead.



Warning When you install the unit, the ground connection must always be made first and disconnected last. Statement 1046

To connect +24 VDC power supply in the Cisco ASR 1002 Router, follow these steps:

SUMMARY STEPS

1. At the rear of the router, check that the power Standby switch is in the Standby position.
2. Ensure that the positive and negative leads are disconnected from the site power source and the source circuit breaker is turned off.
3. Using a wire stripper, strip the recommended amount of wire insulation which is 15mm (0.6 inch) from the negative, positive, and ground leads.
4. Using a 3.5mm screwdriver, insert the screwdriver at an angle to release the spring while you install the stripped lead wire as shown in the image.
5. Carefully push the screwdriver at an angle forward until you relieve the spring contact.
6. With the screwdriver still inserted, gently push the lead wire (ground lead first) in until the copper wire, as shown in the image, is no longer visible (see in the following image).
7. After the lead wire is fully inserted, hold the lead wire in place by pressing inward while you remove the screwdriver to release the spring to tension down on the installed lead wire, then perform these steps:
8. Repeat Steps 5 through Step 10 for each lead wire.
9. After inserting the ground wire, leave an extra service loop in the ground lead to ensure that the ground lead is the last lead to disconnect from the power supply if a great deal of strain is placed on all three leads as shown in the following image.
10. After tightening the receptacle screw for the ground, and leaving the extra service loop in the ground lead, use a cable tie to secure the three leads to the power supply faceplate tie-wrap tab as shown in the above image, item 5.
11. Turn on the branch source breaker.
12. Place the power supply standby switch to the On (I) position. The power supply LEDs light when power is supplied to the router.

DETAILED STEPS

-
- Step 1** At the rear of the router, check that the power Standby switch is in the Standby position.
- Step 2** Ensure that the positive and negative leads are disconnected from the site power source and the source circuit breaker is turned off.
- Step 3** Using a wire stripper, strip the recommended amount of wire insulation which is 15mm (0.6 inch) from the negative, positive, and ground leads.

Note The stripping length is common to all types of wire used.

The following image shows the wire strip and lead.

Figure 29: Stripping Wire for the +24 VDC Terminal Block

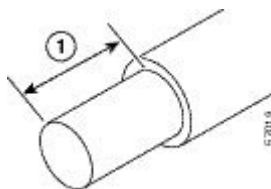

1	Lead wire stripping area	—	—
---	--------------------------	---	---

Warning Remove the covering from exactly the specified length of each wire. If you strip too much of the covering, exposed wire protruding from the terminal block will create an electrical hazard. If you strip too little of the covering, the wire might not make a good contact with the terminal, or it might not be held securely in place in the terminal.

Step 4 Using a 3.5mm screwdriver, insert the screwdriver at an angle to release the spring while you install the stripped lead wire as shown in the image.

Figure 30: Inserting a Screwdriver Into the +24 VDC Power Supply Terminal Block

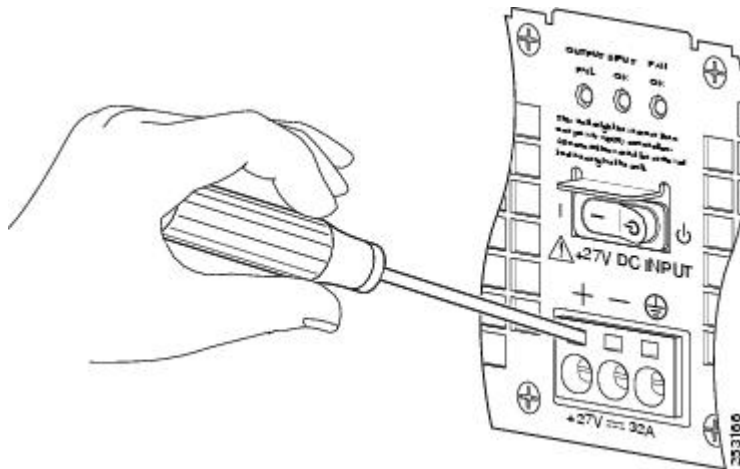

Step 5 Carefully push the screwdriver at an angle forward until you relieve the spring contact.

Step 6 With the screwdriver still inserted, gently push the lead wire (ground lead first) in until the copper wire, as shown in the image, is no longer visible (see in the following image).

Caution Check that there is no copper portion of the lead wire exposed. You only want the wire insulation visible.

Caution Do not install wire into the terminal block that has not had its insulation removed.

Figure 31: Cisco ASR 1002 Router +24 VDC Power Supply Lead Wire Inserted into Terminal Block

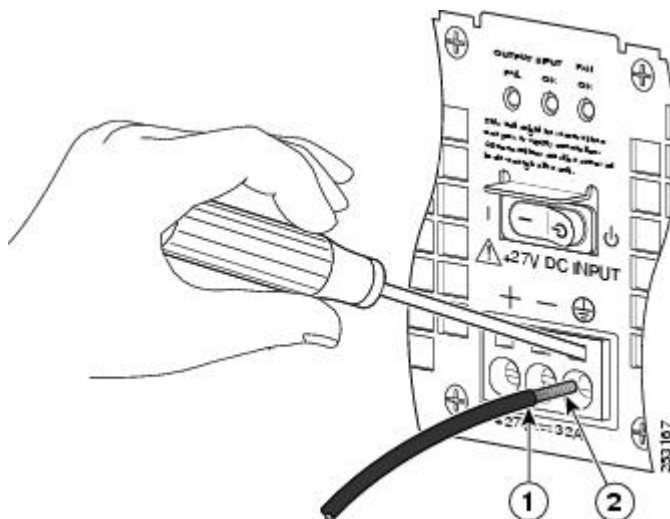

1	Lead wire insulation	2	Copper wire
---	----------------------	---	-------------

The following image shows the lead wire fully inserted.

Figure 32: Cisco ASR 1002 Router +24 VDC Power Supply Lead Wire Fully Inserted

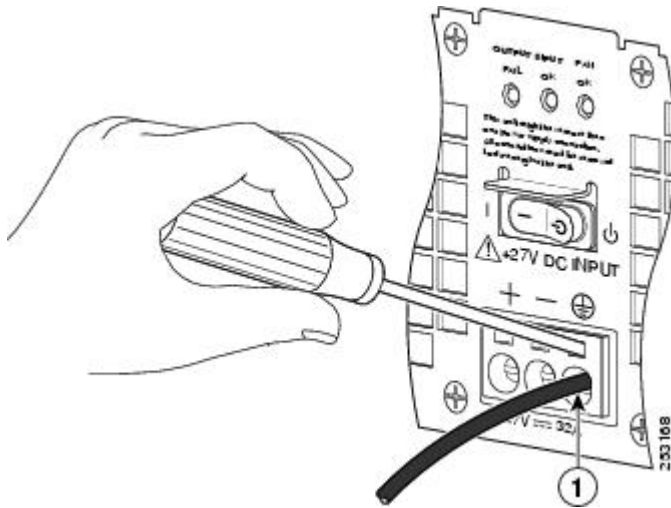

1	Fully-inserted lead wire	—	—
---	--------------------------	---	---

Step 7

After the lead wire is fully inserted, hold the lead wire in place by pressing inward while you remove the screwdriver to release the spring to tension down on the installed lead wire, then perform these steps:

- Hold the lead wire in place while you are removing the screwdriver.
- Once the screwdriver is completely removed, gently pull on the lead wire to make certain that the lead wire is securely installed.

The following shows a lead wire fully inserted, and the screwdriver being removed while you gently pull on the lead wire.

Figure 33: Removing a Screwdriver from the +24 VDC Power Supply Terminal Block

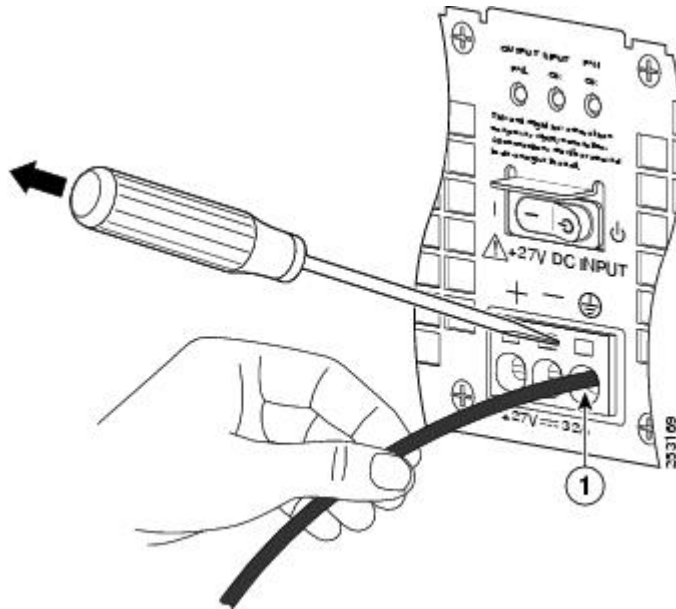

1	Gently pull on lead wire.	—	—
---	---------------------------	---	---

Step 8 Repeat Steps 5 through Step 10 for each lead wire.
The following shows all the lead wires installed.

Figure 34: Cisco +24 VDC Power Supply Terminal Block With Lead Wires Installed

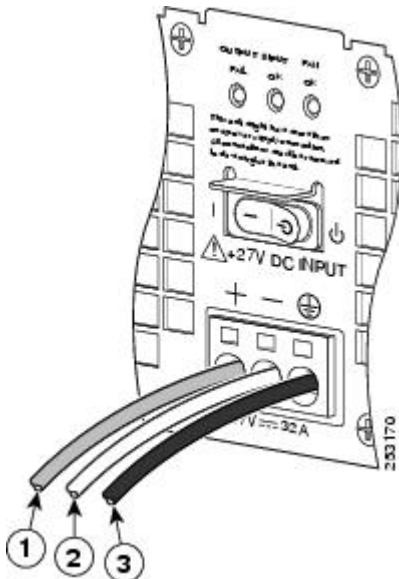

1	Positive lead wire	3	Ground lead wire
2	Negative lead wire	—	—

Note Make sure the stripped end of each lead wire is twisted tightly together. This makes insertion easier. Then make certain the entire lead wire is inserted all the way into its receptacle. If any exposed wire at the stripped end of a lead is visible after inserting the lead into its receptacle, remove the lead from the receptacle, use the wire stripper to cut the stripped end of the lead, and then reinsert.

Caution When securing the ground, positive, and negative +24 VDC-input leads to the power supply faceplate, leave extra service loop in the ground (GND) lead to ensure that the ground lead is the last lead wire to disconnect from the power supply if a great deal of strain is placed on all three leads.

Step 9 After inserting the ground wire, leave an extra service loop in the ground lead to ensure that the ground lead is the last lead to disconnect from the power supply if a great deal of strain is placed on all three leads as shown in the following image.

Figure 35: Cisco +24 VDC Power Supply Terminal Block Ground Lead Service Loop

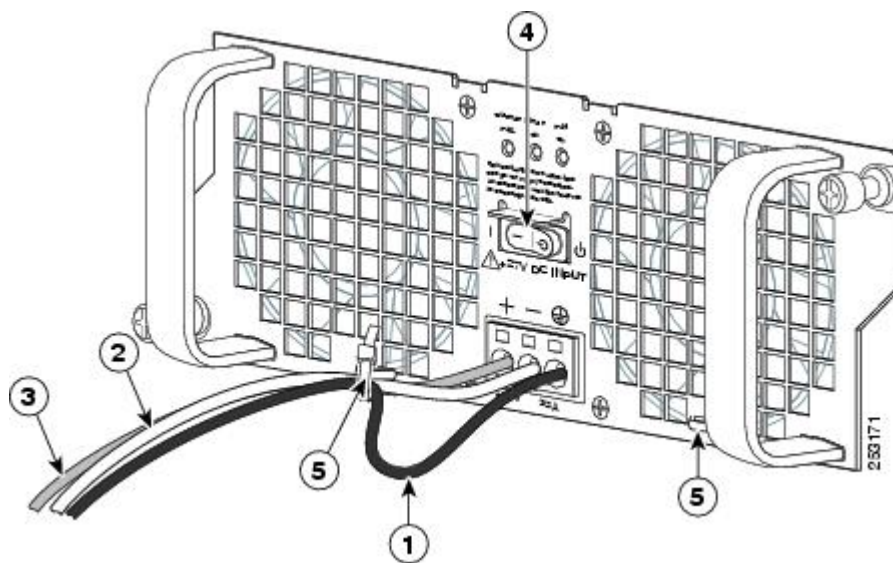

1	Ground lead wire with service loop	4	+24 VDC power supply Standby switch
2	Negative lead wire	5	Power supply tabs
3	Positive lead wire	—	—

Step 10 After tightening the receptacle screw for the ground, and leaving the extra service loop in the ground lead, use a cable tie to secure the three leads to the power supply faceplate tie-wrap tab as shown in the above image, item 5.

Step 11 Turn on the branch source breaker.

Step 12 Place the power supply standby switch to the On (I) position. The power supply LEDs light when power is supplied to the router.

What to do next

This completes the steps for installing the +24 VDC power supply in the Cisco ASR 1002 Router.

Connecting a Terminal to the Cisco ASR1000-RP1 Console Port

The Cisco ASR 1002 embedded route processor has an asynchronous serial (EIA/TIA-232) RJ-45 console port labeled CON on its front panel. You can connect this port to most types of video terminals through use of the console cable kit that is included with your Cisco ASR 1002 Router. The console cable kit contains:

- One RJ-45 to RJ-45 crossover cable
- One RJ-45 to DB-9 (female) adapter

A crossover cable reverses pin connections from one end to the other. In other words, it connects pin 1 (at one end) to pin 8 (at the other end), pin 2 to pin 7, pin 3 to pin 6, and so on. You can identify a crossover cable by comparing the two modular ends of the cable. Hold the cable ends in your hand, side-by-side, with the tabs at the back. Ensure that the wire connected to the outside (left) pin of the left plug (pin 1) is the same color as the wire connected to the outside (right) pin of the right plug (pin 8).

Use the following procedure to connect a video terminal to the console port on a route processor.



Note Each Cisco ASR 1000 Series Route Processor 1 must have a console port connection (typically to a terminal server) if you are running a redundant configuration in the chassis.

SUMMARY STEPS

1. Connect one end of the RJ-45 cables to the serial RJ-45 port (CON) on the Cisco embedded ASR1000-RP1 (see the following image).
2. Run the cable up and through the cable-management bracket and connect the other end of the RJ-45 cable to the RJ-45 adapter (see [Figure 36: Cisco ASR 1002 Router Console Port Connection on Cisco Embedded ASR1000-RP1, on page 46](#)).
3. Connect the adapter to your video terminal to complete the cable connection.
4. Power on your video terminal.
5. Configure your video terminal to match the following default console port settings:
6. Go to the `c_Connecting_Cables_1074149.xml` to continue the installation.

DETAILED STEPS

Step 1 Connect one end of the RJ-45 cables to the serial RJ-45 port (CON) on the Cisco embedded ASR1000-RP1 (see the following image).

Figure 36: Cisco ASR 1002 Router Console Port Connection on Cisco Embedded ASR1000-RP1

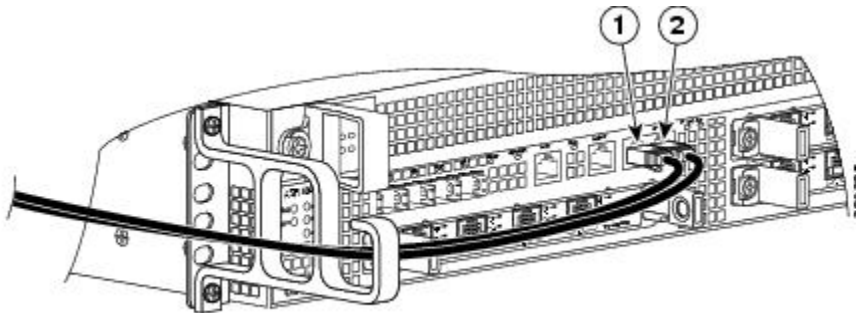

1	CON port connection	2	AUX port connection
---	---------------------	---	---------------------

- Step 2** Run the cable up and through the cable-management bracket and connect the other end of the RJ-45 cable to the RJ-45 adapter (see [Figure 36: Cisco ASR 1002 Router Console Port Connection on Cisco Embedded ASR1000-RP1, on page 46](#)).
- Step 3** Connect the adapter to your video terminal to complete the cable connection.
- Step 4** Power on your video terminal.
- Step 5** Configure your video terminal to match the following default console port settings:
- 9600 baud
 - 8 data bits
 - No parity generation or checking
 - 1 stop bit
 - No flow control
- Step 6** Go to the `c_Connecting_Cables_1074149.xml` to continue the installation.

Connecting Cables

Keep the following guidelines in mind when connecting external cables to the Cisco ASR 1002 Router:

- To reduce the chance of interference, avoid crossing high-power lines with any interface cables
- Verify all cabling limitations (particularly distance) before powering on the system.