



## Card Features

---

This chapter describes features common to the Cisco ONS 15454 suite of cards.



---

**Note** Unless otherwise specified, “ONS 15454” refers to both ANSI and ETSI shelf assemblies.

---



---

**Note** The cards described in this chapter are supported on the Cisco ONS 15454, Cisco ONS 15454 M6, Cisco ONS 15454 M2 platforms, unless noted otherwise.

---



---

**Note** In this chapter, “RAMAN-CTP” refers to the 15454-M-RAMAN-CTP card. “RAMAN-COP” refers to the 15454-M-RAMAN-COP card.

---



---

**Note** In this chapter, “100G-LC-C card” refers to the 15454-M-100G-LC-C card. “10x10G-LC” refers to the 15454-M-10x10G-LC card. “CFP-LC” refers to the 15454-M-CFP-LC card.

---

- [Automatic Laser Shutdown, on page 2](#)
- [Card-Level Indicators, on page 2](#)
- [Port-Level Indicators, on page 5](#)
- [Client Interface, on page 11](#)
- [DWDM Interface, on page 12](#)
- [DWDM Trunk Interface, on page 12](#)
- [FEC, on page 13](#)
- [Timing Synchronization, on page 16](#)
- [Multiplexing Function, on page 18](#)
- [SONET/SDH Overhead Byte Processing, on page 18](#)
- [Client Interface Monitoring, on page 18](#)
- [Jitter, on page 19](#)
- [Lamp Test, on page 19](#)
- [NTP-G335 Performing Lamp Test, on page 19](#)

- [Onboard Traffic Generation, on page 20](#)
- [Performance Monitoring, on page 20](#)
- [Distance Extension, on page 20](#)
- [Interoperability with Cisco MDS Switches, on page 20](#)
- [Client and Trunk Ports, on page 20](#)
- [Automatic Power Control, on page 21](#)
- [Alarms and Thresholds, on page 21](#)
- [Card Protection, on page 21](#)
- [Far-End Laser Control, on page 27](#)
- [Jitter Considerations, on page 28](#)
- [Termination Modes, on page 28](#)

## Automatic Laser Shutdown

The Automatic Laser Shutdown (ALS) procedure is supported on both client and trunk interfaces. On the client interface, ALS is compliant with ITU-T G.664 (6/99). On the data application and trunk interface, the switch on and off pulse duration is greater than 60 seconds and is user-configurable.

For information on ALS provisioning, refer the following procedures, as necessary:

- [NTP-G162 Changing the ALS Maintenance Settings](#)
- [DLP-G203 Changing the ALS Maintenance Settings for OSCM and OSC-CSM Cards](#)
- [DLP-G322 Changing the ALS Maintenance Settings for OPT-BST Card](#)

## Card-Level Indicators

Multiple colored LEDs indicate the status of the card.

### Card-level LEDs for Transponder, Muxponder and Control Cards

The following table lists the three card-level LEDs on the following cards:

- TCC2/TCC2P/TCC3/TNC/TNCE/TSC/TSCE/TNCS
- TXP\_MR\_10G and TXP\_MR\_10E
- TXP\_MR\_10E\_C and TXP\_MR\_10E\_L
- TXP\_MR\_2.5G and TXPP\_MR\_2.5G
- 40E-TXP-C and 40ME-TXP-C
- MXP\_2.5G\_10G and MXP\_2.5G\_10E
- MXP\_2.5G\_10E\_C and MXP\_2.5G\_10E\_L
- MXP\_MR\_2.5G and MXPP\_MR\_2.5G
- MXP\_MR\_10DME\_C and MXP\_MR\_10DME\_L

- 40G-MXP-C, 40E-MXP-C, and 40ME-MXP-C
- GE\_XP, 10GE\_XP, GE\_XPE, and 10GE\_XPE
- ADM-10G
- OTU2\_XP
- TXP\_MR\_10EX\_C
- MXP\_2.5G\_10EX\_C
- MXP\_MR\_10DMEX\_C
- PSM
- TDC-CC and TDC-FC
- AR\_MXP, AR\_XP, and AR\_XPE
- 100G-LC-C, 10x10G-LC, CFP-LC, 100G-ME-C, 100G-CK-C, 100GS-CK-LC, , 200G-CK-LC, 100ME-CKC, 400G-XP-LC

**Table 1: Card-Level Indicators**

Card-Level LED	Description
FAIL LED (Red)	Red indicates that the card's processor is not ready. This LED is on during reset. The FAIL LED flashes during the boot process. Replace the card if the red FAIL LED persists.
ACT/STBY LED Green (Active) Amber (Standby)	Green indicates that the card is operational (one or both ports active) and ready to carry traffic. Amber indicates that the card is operational and in standby (protect) mode.
SF LED (Amber)	Amber indicates a signal failure or condition such as loss of signal (LOS), loss of frame (LOF), or high bit error rates (BERs) on one or more of the card's ports. The amber SF LED is also illuminated if the transmit and receive fibers are incorrectly connected. If the fibers are properly connected and the link is working, the LED turns off.

## Card-level LEDs on the AIC-I Card

**Table 2: Card-Level Indicators on the AIC-I Card**

Card-Level LEDs	Description
Red FAIL LED	Indicates that the card's processor is not ready. The FAIL LED is on during reset and flashes during the boot process. Replace the card if the red FAIL LED persists.
Green ACT LED	Indicates the AIC-I card is provisioned for operation.

Card-Level LEDs	Description
Green/Red PWR A LED	The PWR A LED is green when a supply voltage within a specified range has been sensed on supply input A. It is red when the input voltage on supply input A is out of range.
Green/Red PWR B LED	The PWR B LED is green when a supply voltage within a specified range has been sensed on supply input B. It is red when the input voltage on supply input B is out of range.
Yellow INPUT LED	The INPUT LED is yellow when there is an alarm condition on at least one of the alarm inputs.
Yellow OUTPUT LED	The OUTPUT LED is yellow when there is an alarm condition on at least one of the alarm outputs.
Green RING LED	The RING LED on the local orderwire (LOW) side is flashing green when a call is received on the LOW.
Green RING LED	The RING LED on the express orderwire (EOW) side is flashing green when a call is received on the EOW.

## Card-level LEDs on the MS-ISC-100T Card

*Table 3: Card-Level Indicators on the MS-ISC-100T Card*

Card-Level LEDs	Description
FAIL LED (Red)	The red FAIL LED indicates that the card processor is not ready or that a catastrophic software failure occurred on the card. As part of the boot sequence, the FAIL LED is turned on until the software deems the card operational.
ACT LED (Green)	The green ACT LED provides the operational status of the card. If the ACT LED is green, it indicates that the card is active and the software is operational.

## Card-level LEDs on the Multiplexer, Demultiplexer and Optical Amplifier Cards

The following table lists the card-level LEDs on the following cards:

- 32MUX-O and 32DMX-O
- 4MD-xx.x
- OPT-PRE, OPT-BST, OPT-BST-E, and OPT-BST-L
- OPT-AMP-L, OPT-AMP-17-C, and OPT-AMP-C
- OPT-RAMP-C and OPT-RAMP-CE
- 32WSS and 32WSS-L
- 32DMX, 32DMX-L, 40-DMX-C, 40-DMX-CE, and 40-MUX-C

- 40-WSS-C, 40-WSS-CE, 40-WXC-C, 80-WXC-C, and 16-WXC-FS
- 40-SMR1-C, 40-SMR2-C, 17 SMR9 FS, 24 SMR9 FS, 34 SMR9 FS, and SMR20 FS
- MMU
- OPT-EDFA-17 and OPT-EDFA-24
- EDRA-1-26, EDRA-1-35, EDRA-2-26, and EDRA-2-35

**Table 4: Card-Level Indicators**

Card-Level Indicators	Description
Red FAIL LED	The red FAIL LED indicates that the card's processor is not ready or that there is an internal hardware failure. Replace the card if the red FAIL LED persists.
Green ACT LED	The green ACT LED indicates that the card is carrying traffic or is traffic-ready.
Amber SF LED	The amber SF LED indicates a signal failure on one or more of the card's ports. The amber SF LED also illuminates when the transmit and receive fibers are incorrectly connected. When the fibers are properly connected, the light turns off.

## Card-level LEDs on OSCM and OSC-CSM Cards

**Table 5: Card-Level Indicators on the OSCM and OSC-CSM Cards**

Card-Level Indicators	Description
Red FAIL LED	The red FAIL LED indicates that the card's processor is not ready or that there is an internal hardware failure. Replace the card if the red FAIL LED persists.
Green ACT LED	The green ACT LED indicates that the OSCM or OSC-CSM is carrying traffic or is traffic-ready.
Amber SF LED	The amber SF LED indicates a signal failure or condition such as loss of signal (LOS), loss of frame alignment (LOF), line alarm indication signal (AIS-L), or high BER on one or more of the card's ports. The amber signal fail (SF) LED also illuminates when the transmit and receive fibers are incorrectly connected. When the fibers are properly connected, the light turns off.

## Port-Level Indicators

### Port-level LEDs

For the following cards, the status of the card ports is indicated on the LCD screen of the ONS 15454 fan-tray assembly that displays the number and severity of alarms for a given port or slot.

- OPT-PRE, OPT-BST, OPT-BST-E, and OPT-BST-L

- OPT-AMP-L, OPT-AMP-17-C, and OPT-AMP-C
- OPT-RAMP-C and OPT-RAMP-CE
- RAMAN-CTP and RAMAN-COP
- EDRA-1-26, EDRA-1-35, EDRA-2-26, and EDRA-2-35
- OSCM and OSC-CSM
- 32MUX-O and 32DMX-O
- 4MD-xx.x
- 32WSS and 32WSS-L
- 32DMX, 32DMX-L, 40-DMX-C, 40-DMX-CE, and 40-MUX-C
- 40-WSS-C, 40-WSS-CE, 40-WXC-C, 80-WXC-C, and 16-WXC-FS
- 40-SMR1-C, 40-SMR2-C, 17 SMR9 FS, 24 SMR9 FS, 34 SMR9 FS, and SMR20 FS
- MMU
- OPT-EDFA-17 and OPT-EDFA-24

In some cards, multiple colored LEDs indicate the status of the port.

Port-Level LEDs for AR\_MXP, AR\_XP, and AR\_XPE cards depend on the configured card mode.

The following table lists the port-level LEDs on the following cards:

- TXP\_MR\_10E, TXP\_MR\_10E\_C, and TXP\_MR\_10E\_L
- TXP\_MR\_2.5G and TXP\_MR\_10EX\_C
- 40E-TXP-C and 40ME-TXP-C
- MXP\_2.5G\_10E, MXP\_2.5G\_10E\_C, MXP\_2.5G\_10E\_L, and MXP\_2.5G\_10EX\_C

**Table 6: Port-Level Indicators**

Port-Level LED	Description
Green Client LED	The green Client LED indicates that the client port is in service and that it is receiving a recognized signal. The MXP_2.5G_10E, MXP_2.5G_10E_C, MXP_2.5G_10E_L, and MXP_2.5G_10EX_C cards have four client ports, and so have four client LEDs.
Green DWDM LED	The green DWDM LED indicates that the DWDM port is in service and that it is receiving a recognized signal.

## Port-level LEDs on the TXP\_MR\_10G and MXP\_2.5G\_10G Cards

*Table 7: Port-Level Indicators on the TXP\_MR\_10G and MXP\_2.5G\_10G cards*

Port-Level LED	Description
Green Client LED	The green Client LED indicates that the client port is in service and that it is receiving a recognized signal. The MXP_2.5G_10G card has four client ports, and so has four client LEDs.
Green DWDM LED	The green DWDM LED indicates that the DWDM port is in service and that it is receiving a recognized signal.
Green Wavelength 1 LED	Each port supports two wavelengths on the DWDM side. Each wavelength LED matches one of the wavelengths. This LED indicates that the card is configured for Wavelength 1.
Green Wavelength 2 LED	Each port supports two wavelengths on the DWDM side. Each wavelength LED matches one of the wavelengths. This LED indicates that the card is configured for Wavelength 2.

## Port-level LEDs on the TXPP\_MR\_2.5G Card

*Table 8: Port-Level Indicators on the TXPP\_MR\_2.5G card*

Port-Level LED	Description
Green Client LED	The green Client LED indicates that the client port is in service and that it is receiving a recognized signal.
Green DWDM A LED	The green DWDM A LED indicates that the DWDM A port is in service and that it is receiving a recognized signal.
Green DWDM B LED	The green DWDM B LED indicates that the DWDM B port is in service and that it is receiving a recognized signal.

## Port-level LEDs on the GE\_XP, 10DME and 40G Cards

The following table lists the port-level LEDs on the following cards:

- GE\_XP, 10GE\_XP, GE\_XPE, and 10GE\_XPE
- MXP\_MR\_10DME\_C, MXP\_MR\_10DME\_L, and MXP\_MR\_10DMEX\_C
- 40G-MXP-C, 40E-MXP-C, and 40ME-MXP-C

Table 9: Port-Level Indicators

Port-Level LED	Description
Port LEDs (eight LEDs, four for each group, one for each SFP/XFP)	Green—The client port is either in service and receiving a recognized signal (that is, no signal fail), or Out of Service and Maintenance (OOS,MT or locked, maintenance) in which case the signal fail and alarms will be ignored.
Green/Red/Amber/Off	Red—The client port is in service but is receiving a signal fail (LOS). Amber—The port is provisioned and in a standby state. Off—The SFP is either not provisioned, out of service, not properly inserted, or the SFP hardware has failed.
Green DWDM LED	The green DWDM LED indicates that the DWDM port is in service and that it is receiving a recognized signal.

## Port-level LEDs on the MXP\_MR\_2.5G and MXPP\_MR\_2.5G Cards

Table 10: Port-Level Indicators on the MXP\_MR\_2.5G and MXPP\_MR\_2.5G cards

Port-Level LED	Description
Client LEDs (eight LEDs)	Green indicates that the port is carrying traffic (active) on the interface. Amber indicates that the port is carrying protect traffic (MXPP_MR_2.5G). Red indicates that the port has detected a loss of signal.
DWDM LED (MXP_MR_2.5G) Green (Active) Red (LOS)	Green indicates that the card is carrying traffic (active) on the interface. A red LED indicates that the interface has detected an LOS or LOC.
DWDMA and DWDMB LEDs (MXPP_MR_2.5G) Green (Active) Amber (Protect Traffic) Red (LOS)	Green indicates that the card is carrying traffic (active) on the interface. When the LED is amber, it indicates that the interface is carrying protect traffic in a splitter protection card (MXPP_MR_2.5G). A red LED indicates that the interface has detected an LOS or LOC.

## Port-level LEDs on the ADM-10G and OTU2\_XP Cards



**Note** Client or trunk ports can each be in active or standby mode as defined in the related section for each specific protection type. For example, fiber-switched protection has active or standby trunk ports; 1+1 APS protection has active or standby client ports, and client 1+1 protection does not utilize active or standby ports.



Table 11: Port-Level Indicators on the ADM-10G and OTU2\_XP cards (client and trunk ports)

Port-Level Status	Tri-color LED Description
The port-level LED is active and unprotected.	<ul style="list-style-type: none"> <li>• If a port is in OOS/locked state for any reason, the LED is turned off.</li> <li>• If a port is in IS/unlocked state and the PPM is preprovisioned or is physically equipped with no alarms, the LED is green.</li> <li>• If a port is in IS state and the PPM is physically equipped but does have alarms, the LED is red.</li> </ul>
The port-level LED is in standby.	<ul style="list-style-type: none"> <li>• If a port is in OOS/locked state for any reason, the LED is turned off.</li> <li>• If a port is in the IS/unlocked state and the PPM is preprovisioned or is physically equipped with no alarms, the LED is amber.</li> <li>• If a port is in IS state and physically equipped but does have alarms, the LED is red.</li> </ul>

## Port-level LEDs on the 100G-LC-C, 10x10G-LC, CFP-LC, 100GS-CK-LC, 200G-CK-LC, 100G-CK-C, 100G-ME-C, 100ME-CKC, and 400G-XP-LC Cards

Table 12: Port-Level Indicators

Port-Level LED	Description
Port LEDs (Green/Red/Amber/Off)	<p>Green—The client port is either in service and receiving a recognized signal (that is, no signal fail), or Out of Service and Maintenance (OOS,MT or locked, maintenance) in which case the signal fail and alarms will be ignored.</p> <p>Red—The client port is in service but is receiving a signal fail (LOS).</p> <p>Amber—The port is provisioned and in a standby state.</p> <p>Off—The pluggable is either not provisioned, out of service, not properly inserted, or the pluggable hardware has failed.</p>
DWDM LED Green (Active) Amber (Protect Traffic) Red (LOS)	<p>Green indicates that the card is carrying traffic (active) on the interface.</p> <p>When the LED is amber, it indicates that the interface is carrying protect traffic in a splitter protection card.</p> <p>A red LED indicates that the interface has detected an LOS or LOF.</p>

## Power-level LEDs on the Control Cards

Table 13: Power-Level Indicators on the Control Cards

Power-Level LEDs	Definition
Green/Amber/Red PWR A LED	The PWR A LED is green when the voltage on supply input A is between the low battery voltage (LWBATVG) and high battery voltage (HIBATVG) thresholds. The LED is amber when the voltage on supply input A is between the high battery voltage and extremely high battery voltage (EHIBATVG) thresholds or between the low battery voltage and extremely low battery voltage (ELWBATVG) thresholds. The LED is red when the voltage on supply input A is above extremely high battery voltage or below extremely low battery voltage thresholds.
Green/Amber/Red PWR B LED	The PWR B LED is green when the voltage on supply input B is between the low battery voltage and high battery voltage thresholds. The LED is amber when the voltage on supply input B is between the high battery voltage and extremely high battery voltage thresholds or between the low battery voltage and extremely low battery voltage thresholds. The LED is red when the voltage on supply input B is above extremely high battery voltage or below extremely low battery voltage thresholds.



**Note** The power-level LEDs are either green or red. The LED is green when the voltage on supply inputs is between the extremely low battery voltage and extremely high battery voltage thresholds. The LED is red when the voltage on supply inputs is above extremely high battery voltage or below extremely low battery voltage thresholds.

## Network-level LEDs on the Control Cards

Table 14: Network-Level Indicators on the Control Cards

System-Level LEDs	Definition
Red CRIT LED	Indicates critical alarms in the network at the local terminal.
Red MAJ LED	Indicates major alarms in the network at the local terminal.
Yellow MIN LED	Indicates minor alarms in the network at the local terminal.
Red REM LED	Provides first-level alarm isolation. The remote (REM) LED turns red when an alarm is present in one or more of the remote terminals.
Green SYNC LED	Indicates that node timing is synchronized to an external reference.
Green ACO LED	After pressing the alarm cutoff (ACO) button, the ACO LED turns green. The ACO button opens the audible alarm closure on the backplane. ACO is stopped if a new alarm occurs. After the originating alarm is cleared, the ACO LED and audible alarm control are reset.

## Ethernet Port-level LEDs on the Control Cards

Table 15: Ethernet Port-Level Indicators on the TNC/TNCE/TSC/TSCE/TNCS Cards

Port-Level LEDs	Definition
Green LINK LED	Indicates the connectivity status.
Amber ACT LED	Indicates data reception.

## SFP LEDs on TNC, TNCE, and TNCS Cards

Table 16: TNC, TNCE, and TNCS SFP Indicators

Port Type	Link LED	Activity LED
OC3	<ul style="list-style-type: none"> <li>• RED - No link</li> <li>• GREEN - Link</li> </ul>	—
FE	<ul style="list-style-type: none"> <li>• RED - No link</li> <li>• GREEN - Link</li> </ul>	Blinks on packet flow
GE	<ul style="list-style-type: none"> <li>• RED - No link</li> <li>• GREEN - Link</li> </ul>	Blinks on packet flow

## Client Interface

The client interface in TXP\_MR\_10E, TXP\_MR\_10E\_C, TXP\_MR\_10E\_L, and TXP\_MR\_10EX\_C cards is implemented with a separately orderable XFP module. The module is a tri-rate transceiver, providing a single port that can be configured in the field to support an OC-192 SR-1 (Telcordia GR-253-CORE) or STM-64 I-64.1 (ITU-T G.691) optical interface, as well as 10GE LAN PHY (10GBASE-LR), 10GE WAN PHY (10GBASE-LW), 10G FC signals or IB\_5G signals (TXP\_MR\_10EX\_C only).

The client side XFP pluggable module supports LC connectors and is equipped with a 1310-nm laser.

The MXP\_2.5G\_10E, MXP\_2.5G\_10E\_C, MXP\_2.5G\_10E\_L, and MXP\_2.5G\_10EX\_C cards provide four intermediate- or short-range OC-48/STM-16 ports per card on the client side. Both SR-1 or IR-1 optics can be supported and the ports use SFP connectors. The client interfaces use four lasers of 1310-nm wavelength.

The client interface in AR\_MXP, AR\_XP, and AR\_XPE cards are implemented with a separately orderable XFP/SFP module. The module can be single-rate or tri-rate transceiver, providing a single port that can be configured in the field to support available payloads. For the list of supported payloads, see the section.

## DWDM Interface

The MXP\_2.5G\_10E, MXP\_2.5G\_10E\_C, MXP\_2.5G\_10E\_L, and MXP\_2.5G\_10EX\_C cards serve as an OTN multiplexer, transparently mapping four OC-48 channels asynchronously to ODU1 into one 10-Gbps trunk. The tunable wavelengths for the DWDM trunk is as follows:

- MXP\_2.5G\_10E—Tunable for transmission over four wavelengths in the 1550-nm, ITU 100-GHz spaced channel grid.
- MXP\_2.5G\_10E\_C and MXP\_2.5G\_10EX\_C—Tunable for transmission over the entire C-band and the channels are spaced at 50-GHz on the ITU grid.
- MXP\_2.5G\_10E\_L—Tunable for transmission over the entire L-band and the channels are spaced at 50-GHz on the ITU grid.
- AR\_MXP, AR\_XP, and AR\_XPE—The wavelengths for the DWDM trunk is based on the pluggable.
  - 100G-LC-C, 10X10G-LC, CFP-LC, 100G-ME-C, 100GS-CK-LC, 200G-CK-LC, 100G-CK-C, and 100ME-CKC—Tunable on 96 wavelength channels spaced at 50-GHz on the ITU grid over the entire C band.



### Caution

You must use a 20-dB fiber attenuator (15 to 25 dB) when working with the card in a loopback on the trunk port. Do not use direct fiber loopbacks as it can cause irreparable damage to the card.



### Note

On the MXP\_2.5G\_10EX\_C card, you cannot disable ITU-T G.709 on the trunk side. If ITU-T G.709 is enabled, then FEC cannot be disabled.

## DWDM Trunk Interface

On the trunk side, the TXP\_MR\_10E, TXP\_MR\_10E\_C, TXP\_MR\_10E\_L, and TXP\_MR\_10EX\_C cards provide a 10-Gbps STM-64/OC-192 interface. There are four tunable channels available in the 1550-nm band or eight tunable channels available in the 1580-nm band on the 50-GHz ITU grid for the DWDM interface. The card provides 3R (retime, reshape, and regenerate) transponder functionality for this 10-Gbps trunk interface. Therefore, the card is suited for use in long-range amplified systems. The DWDM interface is compliant with ITU-T G.707, ITU-T G.709, and Telcordia GR-253-CORE standards.

The DWDM trunk port operates at a rate that is dependent on the input signal and the presence or absence of the ITU-T G.709 Digital Wrapper/FEC. The possible trunk rates are:

- OC192 (9.95328 Gbps)
- OTU2 (10.70923 Gbps)
- 10GE (10.3125 Gbps) or 10GE into OTU2 (ITU G.sup43 11.0957 Gbps)
- 10G FC (10.51875 Gbps) or 10G FC into OTU2 (nonstandard 11.31764 Gbps)

- (TXP\_MR\_10EX\_C only) Proprietary rate at the trunk when the client is provisioned as IB\_5G.

The maximum system reach in filterless applications without the use of optical amplification or regenerators is nominally rated at 23 dB over C-SMF fiber. This rating is not a product specification, but is given for informational purposes. It is subject to change.

On the trunk side, the AR\_MXP, AR\_XP, and AR\_XPE cards provide a 10-Gbps OTU2 or 2.5-Gbps OTU1 or 4-Gbps FC interfaces. The trunk wavelength can be tuned to any C-band wavelength, based on the pluggable inserted. The card provides 3R (retime, reshape, and regenerate) transponder functionality for this 10-Gbps trunk interface. Therefore, the card is suited for use in the long-range amplified systems. The DWDM interface is compliant with ITU-T G.707, ITU-T G.709, and Telcordia GR-253-CORE standards. The DWDM trunk port operates at a rate that is dependent on the input signal and the presence or absence of the ITU-T G.709 Digital Wrapper/FEC.

The maximum system reach in filterless applications without the use of optical amplification or regenerators is nominally rated at 23 dB over C-SMF fiber. This rating is not a product specification, but is given for informational purposes. It is subject to change.

## FEC

Forward error correction (FEC) is a feature used for controlling errors during data transmission. This feature works by adding data redundancy to the transmitted message using an algorithm. This redundancy allows the receiver to detect and correct a limited number of errors occurring anywhere in the message, instead of having to ask the transmitter to resend the message.

### FEC Modes for the TXP\_MR\_10E and MXP\_2.5G\_10E Cards

For the TXP\_MR\_10E, TXP\_MR\_10E\_C, TXP\_MR\_10E\_L, MXP\_2.5G\_10E, MXP\_2.5G\_10E\_C, MXP\_2.5G\_10E\_L, TXP\_MR\_10EX\_C, or MXP\_2.5G\_10EX\_C card, you can configure the forward error correction in three modes: NO FEC, FEC, and E-FEC modes.

The E-FEC mode has a higher level of error detection and correction than the FEC mode. As a result, using the E-FEC mode allows higher sensitivity (that is, a lower optical signal-to-noise ratio [OSNR]) with a lower bit error rate than what the FEC mode allows. The E-FEC mode also enables longer distance trunk-side transmission than what the FEC enables.

The output bit rate is always 10.7092 Gbps as defined in the ITU-T G.709 standard, but the error coding performance can be provisioned in this way:

- NO FEC—No forward error correction
- FEC—Standard ITU-T G.975 Reed-Solomon algorithm
- E-FEC—Standard ITU-T G.975.1 I.7, two orthogonally concatenated BCH super FEC code. This FEC scheme contains three parameterizations of a single scheme of two orthogonally interleaved BCH. The constructed code is decoded iteratively to achieve the expected performance.

### FEC Modes for the AR\_MXP, AR\_XP and AR\_XPE Cards

For the AR\_MXP, AR\_XP, and AR\_XPE cards you can configure forward error correction on 10 Gbps trunk XFP ports in four modes: NO FEC, FEC, I.4 E-FEC, and I.7 E-FEC. The 2.5Gbps SFP OTN ports have only

two modes of operation: NO FEC and FEC. The output bit rate varies depending on the provisioned payload and the configured FEC. The details of the error-coding performance that can be provisioned are:

- NO FEC—No forward error correction
- FEC—Standard ITU-T G.975 Reed-Solomon algorithm
- I.4 E-FEC—Standard G.975.1 I.4 two interleaved codes (RS and BCH) super FEC codes
- I.7 E-FEC—Standard G.975.1 I.7 two orthogonally concatenated block (BCH) super FEC codes; this FEC scheme contains three parameterizations of a single scheme of two BCH codes, with the constructed code decoded iteratively to achieve expected performance.



---

**Note** G.709 OTN is enabled by default for all trunk ports, except for a 4GFC transponder.

---

## FEC Modes for 100G-LC-C, CFP-LC, 100G-CK-C, 100GS-CK-LC, 200G-CK-LC, and 400G-XP-LC Cards

The cards support multiple FEC modes on its trunk and client interfaces.

- FEC—Standard ITU-T G.975 Reed-Solomon algorithm with 7% overhead.
- I.7 FEC—Standard G.975.1 I.7 two orthogonally concatenated block (BCH) super FEC codes; this FEC scheme contains three parameterizations of a single scheme of two BCH codes, with the constructed code decoded iteratively to achieve expected performance.
- Soft Decision FEC—Employs an advanced differential encoding and cycle slip-aware algorithm offering excellent performance and robustness against high cycle slip rates. The SD-FEC is suitable for applications where maintaining sufficient signal to noise ratio is important. Examples include long haul and ultra-long haul 100G transmission, and wavelengths employing high order modulation schemes such as 16QAM.
- High Gain FEC—High Gain FEC with 7% or 20% overhead provides better performance than the standard G.975.1. The HG-FEC is suitable for all applications where 100G wavelengths are passing through a high number of ROADMs, with limited pass-band performance.



---

**Note** G.709 OTN is enabled by default for OTU payloads.

---

- Hard Decision FEC—The HD-FEC with 7% overhead can be provisioned on the 100GS-CK-LC and 200G-CK-LC cards to allow trunk interoperability with the 100G-LC-C and 100G-CK-LC (older Line Cards). The 100GS-CK-LC and 200G-CK-LC cards provisioned with 7% HD-FEC has 0.5dB better B2B OSNR sensitivity than the 100G-LC-C and 100G-CK-LC cards. This FEC mode is available for all 100G operating modes.

Table 17: Supported FEC Modes for 100G-LC-C, 10x10G-LC, CFP-LC, 100G-CK-C, 100GS-CK-LC, 200G-CK-LC, and 400G-XP-LC Cards

Card	Supported FEC Modes
100G-LC-C	<ul style="list-style-type: none"> <li>• Standard</li> <li>• 7% High Gain</li> <li>• 20% High Gain</li> </ul>
CFP-LC	<ul style="list-style-type: none"> <li>• GFEC</li> </ul>
100G-CK-C	<ul style="list-style-type: none"> <li>• Standard</li> <li>• 7% High Gain</li> <li>• 20% High Gain</li> </ul>
100GS-CK-LC	<ul style="list-style-type: none"> <li>• Standard</li> <li>• 7% Hard Decision</li> <li>• 20% Soft Decision</li> </ul>
200G-CK-LC	<ul style="list-style-type: none"> <li>• Standard</li> <li>• 7% Hard Decision</li> <li>• 20% Soft Decision</li> </ul>
400G-XP-LC	<ul style="list-style-type: none"> <li>• 15% Soft Decision Differential Encoding (DE) OFF</li> <li>• 25% Soft Decision Differential Encoding (DE) OFF</li> <li>• 15% Soft Decision Differential Encoding (DE) ON</li> <li>• 25% Soft Decision Differential Encoding (DE) ON</li> </ul>

## FEC Threshold Bit Error Correction Values

The maximum bit error correction value in R9.6.0.3 is lesser than the maximum bit error correction value in earlier releases. During an upgrade to R9.6.0.3, the value of the Bit Errors Corrected does not change. In CTC, the maximum bit error correction value can be manually reconfigured in the card view > Provisioning > OTN > FEC Threshold tab using the values provided in the following table.

Table 18: FEC Threshold Bit Error Correction Values

Data Rate	Bit Error Correction	Frames per Second	Bit Error Correction per Second	Maximum Bit Error Correction per 15 Seconds
Releases earlier than R9.6.0.3				
Any data rate	122368	82026	10037357568	9033621811200
R9.6.0.3				
OTU1	4096	20421	83644416	75279974400
OTU2	4096	82026	335978496	302380646400
OTU3	4096	329492	1349599232	1214639308800
OTU4	4096	856164	3506847744	3156162969600

## Client-to-Trunk Mapping

The TXP\_MR\_10E, TXP\_MR\_10E\_C, TXP\_MR\_10E\_L, TXP\_MR\_10EX\_C, AR\_MXP, AR\_XP, and AR\_XPE cards can perform ODU2-to-OCh mapping, which allows operators to provision data payloads in a standard way across 10-Gbps optical links. Additionally, the AR\_MXP, AR\_XP, and AR\_XPE cards can perform ODU1-to-OCh mapping across 2.5 Gbps optical links.

Digital wrappers that define client side interfaces are called Optical Data Channel Unit 2 (ODU2) entities in ITU-T G.709. Digital wrappers that define trunk side interfaces are called Optical Channels (OCh) in ITU-T G.709. ODU2 digital wrappers can include Generalized Multiprotocol Label Switching (G-MPLS) signaling extensions to ITU-T G.709 (such as Least Significant Part [LSP] and Generalized Payload Identifier [G-PID] values) to define client interfaces and payload protocols.

## Timing Synchronization

The TCC2/TCC2P/TCC3 card performs all system-timing functions for each ONS 15454. The TNC/TNCE/TSC/TSCE/TNCS card performs all the system-timing functions for the ONS 15454 M2, ONS 15454 M6, and ONS 15454 M15 shelves.



**Note** Due to memory limitations, TCC2/TCC2P cards are not supported from Release 10.5.2 onwards. As a result, in a multishelf configuration, the TCC2/TCC2P card cannot be a node controller or a shelf controller. Upgrade the TCC2/TCC2P card to a TCC3 card.

The control card monitors the recovered clocks from each traffic card and two BITS ports for frequency accuracy. The control card selects a recovered clock, a BITS, or an internal Stratum 3 reference as the system-timing reference. You can provision any of the clock inputs as primary or secondary timing sources. A slow-reference tracking loop allows the control card to synchronize with the recovered clock, which provides holdover if the reference is lost. The control card supports 64/8K composite clock and 6.312 MHz timing output.





---

**Note** The TNC/TNCE/TSC/TSCE/TNCS card supports the BITS-1 and BITS-2 external timing interfaces on the ONS 15454 M6 and NCS 2015 shelves. The card supports the BITS-1 interface on the ONS 15454 M2 shelf.

---

The TNC/TNCE/TSC/TSCE/TNCS card supports SNTP operation that allows the nodes to synchronize the system clock automatically with a reference SNTP server following system reboots, card resets, and software upgrades.

For more information on the timing function, see [Timing Reference](#) document.

The MXP\_2.5G\_10G card is synchronized to the the control card clock during normal conditions and transmits the ITU-T G.709 frame using this clock. The control card can operate from an external building integrated timing supply (BITS) clock, an internal Stratum 3 clock, or from clock recovered from one of the four valid client clocks. If clocks from both the control cards are not available, the MXP\_2.5G\_10G card switches automatically (with errors, not hitless) to an internal 19.44 MHz clock that does not meet SONET clock requirements. This will result in a clock alarm.

The MXP\_2.5G\_10E and MXP\_2.5G\_10EX\_C cards are synchronized to the control clock and the MXP\_2.5G\_10E\_C and MXP\_2.5G\_10E\_L cards are synchronized to the control card clock during normal conditions and transmits the ITU-T G.709 frame using this clock. No holdover function is implemented. If neither control clock is available, the cards switch automatically (hitless) to the first of the four valid client clocks with no time restriction as to how long it can run on this clock. The cards continue to monitor the control card. If a control card is restored to working order, the cards revert to the normal working mode of running from the control-card clock. If no valid control-card clock is available and all of the client channels become invalid, the cards wait (no valid frames processed) until the control card supplies a valid clock. In addition, the cards can select the recovered clock from one active and valid client channel and supply that clock to the control card card.

The AR\_MXP, AR\_XP, and AR\_XPE cards are able to transparently transport synchronization and timing information for payload enveloped within ODU-1 and ODU-2. The AR\_MXP and AR\_XP cards are synchronized to the control card clock during normal conditions and transmit the ITU-T G.709 frame using this clock. The AR\_XPE card is synchronized to the control card clock during normal conditions and transmit the ITU-T G.709 frame using this clock. The AR\_MXP, AR\_XP, and AR\_XPE cards select its synchronization source between an optical line, an external synchronization input, and the internal source. The optical line can be either OCN, OTN or Ethernet based. The AR\_MXP and AR\_XP cards transmit the SyncE information from an incoming SyncEthernet (ITU-T G.8262 and G.8264 ESMC) signal to the node controller (TNC).

The 100G-LC-C, 10x10G-LC, CFP-LC, 100G-ME-C, 100G-CK-C, and 100ME-CKC cards are synchronized to TNC/TSC/TNCE/TSCE/TNCS clock during normal conditions and transmits the ITU-T G.709 frame using this clock.

The 100GS-CK-LC and 200G-CK-LC cards cannot be used as a timing reference source.



---

**Note** Only one port per card can be selected as a timing reference. The OTN ports configured as clients shall not be provisionable as timing source.

---

## Multiplexing Function

The muxponder is an integral part of the reconfigurable optical add/drop multiplexer (ROADM) network. The key function of the MXP\_2.5G\_10E, MXP\_2.5G\_10E\_C, MXP\_2.5G\_10E\_L, MXP\_2.5G\_10EX\_C, AR\_MXP, AR\_XP, and AR\_XPE cards is to multiplex 4 OC-48/STM16 signals onto one ITU-T G.709 OTU2 optical signal (DWDM transmission). The multiplexing mechanism allows the signal to be terminated at a far-end node by another similar card.

Termination mode transparency on the muxponder is configured using OTUx and ODUx OH bytes. The ITU-T G.709 specification defines OH byte formats that are used to configure, set, and monitor frame alignment, FEC mode, section monitoring, tandem connection monitoring, and termination mode transparency.

The card performs ODU to OTU multiplexing as defined in ITU-T G.709. The ODU is the framing structure and byte definition (ITU-T G.709 digital wrapper) used to define the data payload coming into one of the SONET/SDH client interfaces on the card. The term ODU1 refers to an ODU that operates at 2.5-Gbps line rate. On the card, four client interfaces can be defined using ODU1 framing structure and format by asserting an ITU-T G.709 digital wrapper.

The output of the muxponder is a single 10-Gbps DWDM trunk interface defined using OTU2. It is within the OTU2 framing structure that FEC or E-FEC information is appended to enable error checking and correction.

## SONET/SDH Overhead Byte Processing

The MXP\_2.5G\_10E, MXP\_2.5G\_10E\_C, MXP\_2.5G\_10E\_L, MXP\_2.5G\_10EX\_C, AR\_MXP, AR\_XP, AR\_XPE, 100G-LC-C, 10x10G-LC, CFP-LC, 100G-CK-C, 100GS-CK-LC, 200G-CK-LC, 100G-ME-C, and 100ME-CKC cards pass the incoming SONET/SDH data stream and its overhead bytes for the client signal transparently. The card can be provisioned to terminate regenerator section overhead. This is used to eliminate forwarding of unneeded layer overhead. It can help reduce the number of alarms and help isolate faults in the network.

## Client Interface Monitoring

The following parameters are monitored on the MXP\_2.5G\_10E, MXP\_2.5G\_10E\_C, MXP\_2.5G\_10E\_L, MXP\_2.5G\_10EX\_C, AR\_MXP, AR\_XP, AR\_XPE, 100G-LC-C, 10x10G-LC, CFP-LC, 100G-CK-C, 100GS-CK-LC, , 200G-CK-LC, 100G-ME-C, and 100ME-CKC cards:

- Laser bias current is measured as a PM parameter
- LOS is detected and signaled
- Transmit (TX) and receive (RX) power are monitored

The following parameters are monitored in real time mode (one second):

- Optical power transmitted (client)
- Optical power received (client)

In case of loss of communication (LOC) at the DWDM receiver or far-end LOS, the client interface behavior is configurable. AIS can be invoked or the client signal can be squelched.

## Jitter

For SONET and SDH signals, the MXP\_2.5G\_10E, MXP\_2.5G\_10E\_C, MXP\_2.5G\_10E\_L, MXP\_2.5G\_10EX\_C, AR\_MXP, AR\_XP, AR\_XPE cards comply with Telcordia GR-253-CORE, ITU-T G.825, and ITU-T G.873 for jitter generation, jitter tolerance, and jitter transfer. For more information, see the [Jitter Considerations, on page 28](#).

## Lamp Test

The MXP\_2.5G\_10E, MXP\_2.5G\_10E\_C and MXP\_2.5G\_10E\_L, MXP\_2.5G\_10EX\_C, AR\_MXP, AR\_XP, AR\_XPE, TDC-CC, TDC-FC, TNC, TNCE, TSC, TSCE, TNCS, RAMAN-CTP, and RAMAN-COP cards support lamp test function activated from the shelf front panel or through CTC to ensure that all LEDs are functional.

The Lamp Test is run during the initial node turn-up, periodic maintenance routine, identification of specific cards, or LED testing.

## NTP-G335 Performing Lamp Test

<b>Purpose</b>	This procedure performs lamp test at the shelf and card levels.
<b>Tools/Equipment</b>	None
<b>Prerequisite Procedures</b>	<a href="#">DLP-G46 Log into CTC</a>
<b>Required/As Needed</b>	As needed
<b>Onsite/Remote</b>	Onsite or remote
<b>Security Level</b>	Superuser only

### Procedure

- 
- Step 1** In node view (single-shelf mode) or multishelf view (multishelf mode), click the **Maintenance**> **Diagnostic** tab.
- Step 2** Click the **Lamp Test** button. The **Lamp Test** dialog box appears.
- Step 3** Perform lamp test at the shelf level.
- Select the **All** option.
  - Click **Lamp Test**.
- Step 4** Perform lamp test at the card level.
- Select the **Lamp Test For Slot** option
  - Choose the required Slot ID or card from the drop-down list.

- Click **Slot Lamp Test**.

**Note** Cards in pre-provisioned or improper removal state are not listed in the drop-down list.

**Stop. You have completed this procedure.**

---

## Onboard Traffic Generation

The MXP\_2.5G\_10E, MXP\_2.5G\_10E\_C, MXP\_2.5G\_10E\_L, and MXP\_2.5G\_10EX\_C cards provide internal traffic generation for testing purposes according to pseudo-random bit sequence (PRBS), SONET/SDH, or ITU-T G.709.

## Performance Monitoring

GFP-T performance monitoring (GFP-T PM) in MXP\_MR\_2.5G, MXPP\_MR\_2.5G, AR\_MXP, AR\_XP, AR\_XPE, 100G-LC-C, 10x10G-LC, 100G-CK-C, 100GS-CK-LC, 200G-CK-LC, 100G-ME-C, and 100ME-CKC cards are available via remote monitoring (RMON), and trunk PM is managed according to Telcordia GR-253-CORE and ITU G.783/826. Client PM is achieved through RMON for FC and GE.

## Distance Extension

In MXP\_MR\_2.5G and MXPP\_MR\_2.5G cards, buffer-to-buffer credit management scheme provides FC flow control. When this feature is enabled, a port indicates the number of frames that can be sent to it (its buffer credit), before the sender is required to stop transmitting and wait for the receipt of a “ready” indication. The MXP\_MR\_2.5G and MXPP\_MR\_2.5 cards support FC credit-based flow control with a buffer-to-buffer credit extension of up to 1600 km (994.2 miles) for 1G FC and up to 800 km (497.1 miles) for 2G FC. The feature can be enabled or disabled, as necessary.

## Interoperability with Cisco MDS Switches

You can provision a string (port name) for each fiber channel/FICON interface on the MXP\_MR\_2.5G and MXPP\_MR\_2.5G cards, which allows the MDS Fabric Manager to create a link association between that SAN port and a SAN port on a Cisco MDS 9000 switch.

## Client and Trunk Ports

The MXP\_MR\_2.5G card features a 1550-nm laser for the trunk/line port and a 1310-nm or 850-nm laser (depending on the SFP) for the client ports. The card contains eight 12.5 degree downward tilt SFP modules for the client interfaces. For optical termination, each SFP uses two LC connectors, which are labeled TX and RX on the faceplate. In a MXP\_MR\_2.5G card, the trunk port is a dual-LC connector with a 45 degree downward angle. In a MXPP\_MR\_2.5G card, there are two trunk port connectors (one for working and one for protect), each a dual-LC connector with a 45-degree downward angle.

## Automatic Power Control

A transient gain range of 20 to 23 dB is available to APC in order to permit other amplifiers to reach their expected set points. However, operation in this range is not continuous. At startup, the OPT-AMP-17-C card caps the gain at a maximum of 20 dB.



**Note** When the OPT-AMP-17-C operates as a booster amplifier, APC does not control its gain.

## Alarms and Thresholds

The following table lists the alarms and its related thresholds for the OSC-CSM card.

**Table 19: Alarms and Thresholds**

Port	Alarms	Thresholds
LINE RX	LOS	None
	LOS-P	LOS-P Fail Low
	LOS-O	LOS-O Fail Low
LINE TX	None	None
OSC TX	OPWR-DEG-HIGH	OPWR-DEG-HIGH Th
	OPWR-DEG-LOW	OPWR-DEG-LOW Th
	OPWR-FAIL-LOW	OPWR-FAIL-LOW Th
OSC RX	None	None
COM TX	None	None
COM RX	LOS-P	LOS-P Fail Low

## Card Protection

### Y-Cable and Splitter Protection

Y-cable and splitter protection are two main forms of card protection that are available for TXP, MXP, AR\_MXP, AR\_XP, AR\_XPE, and Xponder (GE\_XP, 10GE\_XP, GE\_XPE, 10GE\_XPE, and OTU2\_XP) cards when they are provisioned in TXP or MXP mode. Y-cable protection is provided at the client port level. Splitter protection is provided at the trunk port level.



**Note** GE\_XP, 10GE\_XP, GE\_XPE, and 10GE\_XPE cards use VLAN protection when they are provisioned in L2-over-DWDM mode. For more information, see the [Layer 2 Over DWDM Protection, on page 27](#). The ADM-10G card uses path protection and 1+1 protection. For more information, see the [Protection](#) section.

## Y-Cable Protection Availability on TXP, MXP, and Xponder Cards

Y-cable protection is available for the following ONS 15454 TXP, MXP, and Xponder cards:

- TXP\_MR\_10G
- TXP\_MR\_10E
- TXP\_MR\_2.5G
- 40E-TXP-C
- 40ME-TXP-C
- MXP\_2.5G\_10G
- MXP\_2.5G\_10E
- MXP\_2.5G\_10E\_C
- MXP\_2.5G\_10E\_L
- MXP\_MR\_2.5G
- MXP\_MR\_10DME\_C
- MXP\_MR\_10DME\_L
- 40G-MXP-C
- 40E-MXP-C
- 40ME-MXP-C
- GE\_XP and GE\_XPE (when in 10GE or 20GE MXP card mode)
- 10GE\_XP and 10GE\_XPE (when in 10GE TXP card mode)
- OTU2\_XP (when in Transponder card configuration)
- AR\_MXP
- AR\_XP
- AR\_XPE
- 10x10G-LC (when in TXP-10G or MXP-10G mode)—The client ports of the 10x10G-LC cards are provisioned with OC192/STM-64, 10GE-LAN, OTU2, OTU2e, 8G FC, and 10G FC payloads.

Y-cable protection is supported when the 10x10G-LC card is configured in MXP-10x10G operating mode with 200G-CK-LC card and the 10x10G-LC card is provisioned with 10GE, OC-192/STM-64 payloads. This configuration uses the ONS-SC+-10G-LR and ONS-SC+-10G-SR pluggables.



---

**Note** A hardware reset or a hardware failure of the active 10x10G-LC card configured in the TXP-10G or MXP-10G mode in a Y-cable configuration causes a protection switchover that may result in a traffic hit of more than 50 msec.

---

- CFP-LC (when in CFP-TXP mode)—The client ports of the CFP-LC cards are provisioned with 100GE payloads. This configuration uses only the CFP LR4 pluggable.
- CFP-LC (when in CFP-MXP mode)—The client ports of the CFP-LC cards are provisioned with 40GE payloads. This configuration uses only the CFP LR4 pluggable.
- 200G-CK-LC (when in TXP-100G mode)—Y-cable protection is supported when the 200G-CK-LC card is configured in TXP-100G operating mode and the 100G client CPAK ports are provisioned with 100GE payload. This configuration uses the CPAK-100G-LR4 pluggable.
- 100G-CK-C—The client ports of the 100G-CK-C cards are provisioned with 100GE/OTU4 payloads. This configuration uses only the CPAK-100G-LR4 pluggable.
- 100GS-CK-LC and 200G-CK-LC—Y-cable protection is supported in MXP-10x10G operating mode.

## Setting-up Y-Cable Protection

To set up Y-cable protection, create a Y-cable protection group for two TXP, MXP, or Xponder cards using Cisco Transport Controller (CTC). Next, connect the client ports of the two cards physically with a Y-cable. The single client signal is sent into the RX Y-cable and is split between the two TXP, MXP, or Xponder cards. The two TX signals from the client side of the TXP, MXP, or Xponder cards are combined in the TX Y-cable into a single client signal. Only the active card signal passes through as the single TX client signal. CTC automatically turns off the laser on the protect card to avoid signal interference where the Y-cable joins.

On the GE\_XP, 10GE\_XP, GE\_XPE, 10GE\_XPE, and OTU2\_XP cards, the Y-cable protection mechanism is provisionable and can be set ON or OFF (OFF is the default mode).

When a signal fault is detected, the protection mechanism software automatically switches between paths. Y-cable protection also supports revertive and nonrevertive mode.

When an MXP\_MR\_2.5G, MXP\_MR\_10DME\_C, MXP\_MR\_10DME\_L, AR\_MXP, AR\_XP, or AR\_XPE card that is provisioned with Y-cable protection is used on a storage ISL link (ESCON, FC1G, FC2G, FC4G, FICON1G, FICON2G, FICON4G, or ISC-3 1/2G), a protection switchover resets the standby port to active. This reset reinitialises the end-to-end link to avoid any link degradation caused due to loss of buffer credits during switchover and results in an end-to-end traffic hit of 15 to 20 seconds.

When using the MXP\_MR\_10DME\_C or MXP\_MR\_10DME\_L card, enable the fast switch feature and use it with a Cisco MDS storage switch to avoid this 15 to 20 second traffic hit. When enabling fast switch on the MXP\_MR\_10DME\_C or MXP\_MR\_10DME\_L card, ensure that the attached MDS switches have the buffer-to-buffer credit recovery feature enabled.

You can also use the TXP\_MR\_2.5G card to avoid this 15 to 20 second traffic hit. When a Y-cable protection switchover occurs, the storage ISL link does not reinitialize and results in an end-to-end traffic hit of less than 50 ms.

AR\_MXP, AR\_XP, and AR\_XPE cards support Y-cable protection on the client ports, which are part of an unprotected card mode. The Y-cable protection is not supported for video and auto payloads.

When using the AR\_MXP, AR\_XP, or AR\_XPE card on storage ISL link, use it with a Cisco MDS storage switch to avoid this 15 to 20 second traffic hit.

When the active AR\_MXP, AR\_XP, AR\_XPE card is removed from the shelf, there is a traffic hit of 60 to 100 ms.



---

**Note** Y-cable connectors will not work with electrical SFPs because Y-cables are made up of optical connectors and it is not possible to physically connect them to an electrical SFP. Y-cable protection is not supported on IB\_5G.

---



---

**Note** There is a traffic hit of up to a couple hundred milliseconds on the MXP\_MR\_2.5G and MXP\_MR\_10DME cards in Y-cable configuration when a fiber cut or SFP failure occurs on one of the client ports.

---



---

**Note** If you create a GCC on either card of the protect group, the trunk port stays permanently active, regardless of the switch state. When you provision a GCC, you are provisioning unprotected overhead bytes. The GCC is not protected by the protect group.

---



---

**Note** Loss of Signal–Payload (LOS-P) alarms, also called Incoming Payload Signal Absent alarms, can occur on a split signal if the ports are not in a Y-cable protection group.

---



---

**Note** Removing an SFP from the client ports of a card in a Y-cable protection group card causes an IMPROPRMVL (PPM) alarm. The working and protected port raises the IMPROPRMVL alarm. The severity on the client ports is changed according to the protection switch state.

---



---

**Note** On the OTU2\_XP card, when the 10G Ethernet LAN Phy to WAN Phy conversion feature is enabled, Y-cable protection is not supported on the LAN to WAN interface (ports 1 and 3).

---





**Note** When using fixed DWDM or tunable XFPs for Y-cable protection, the protection switch time may exceed 50 ms.

The following figure shows the Y-cable signal flow.

**Figure 1: Y-Cable Protection**

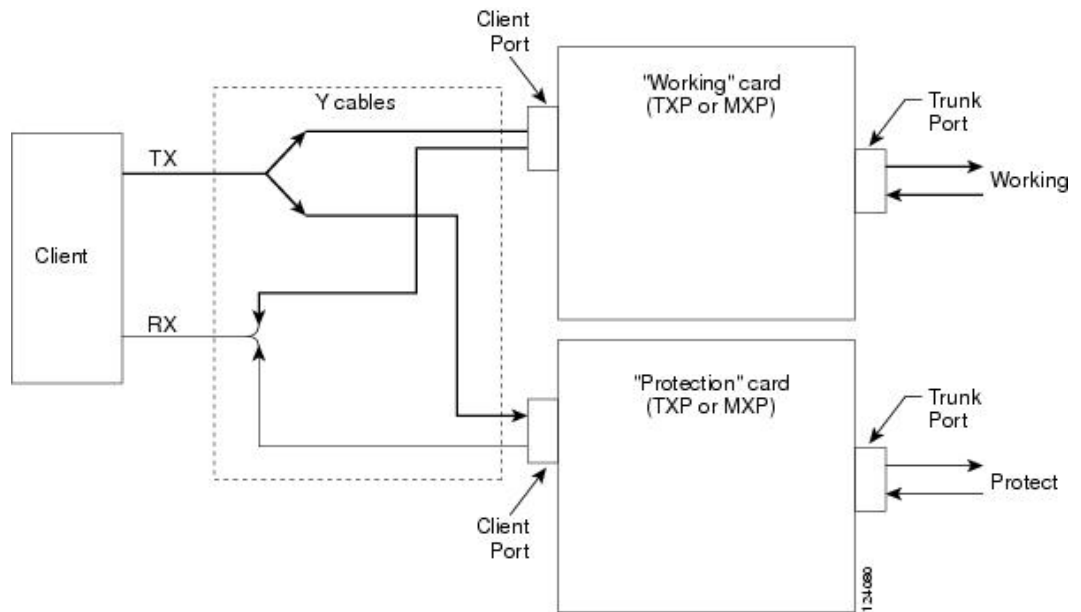

## Splitter Protection

Splitter protection, shown in the following figure, is provided with TXPP cards, MXPP cards, and OTU2\_XP cards (on trunk ports that are not part of a regenerator group). You can create and delete splitter protection groups in OTU2\_XP card.

To implement splitter protection, a client injects a single signal into the client RX port. An optical splitter internal to the card then splits the signal into two separate signals and routes them to the two trunk TX ports. The two signals are transmitted over diverse optical paths. The far-end MXPP or TXPP card uses an optical switch to choose one of the two trunk RX port signals and injects it into the TX client port. When using splitter protection with two MXPP or TXPP cards, there are two different optical signals that flow over diverse paths in each direction. In case of failure, the far-end switch must choose the appropriate signal using its built-in optical switch. The triggers for a protection switch are LOS, LOF, SF, or SD.

In the splitter protected 10G Ethernet LAN Phy to WAN Phy mode, AIS-P and LOP-P acts as trigger (when G.709 is enabled) for the Protection Switch, in addition to the existing switching criteria.

In the OTU2\_XP card, the STS parameters such as, SF /SD thresholds, Path PM thresholds, and Path Trace is set for the working path (Port 3). The same parameters are also applicable for the protected path (Port 4).

Figure 2: Splitter Protection

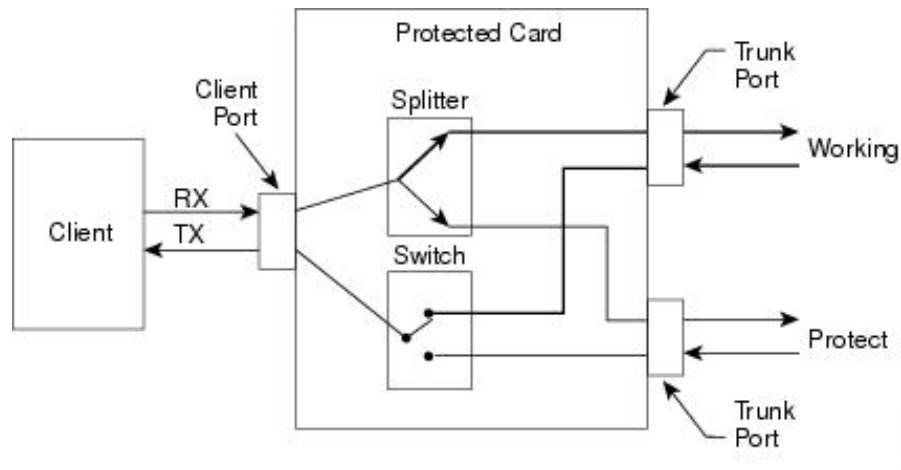

## 1+1 Protection

The 1+1 protection is available for the GE\_XP, GE\_XPE, 10GE\_XP, and 10GE\_XPE cards:

The 1+1 protection is provided in the Layer 2 (L2) card mode to protect against client port and card failure. 1+1 protection is supported in both single shelf and multishelf setup. This means that the working card can be in one shelf and the protect card can be in another shelf of a multishelf setup. Communication between the two cards is across 10 Gigabit Ethernet interconnection interface using Ethernet packets. The Inter link (ILK) trunk or internal pathcord must be provisioned on both the cards. This link is used to transmit protection switching messages and data.



**Note** With 1+1 protection mechanisms, the switch time of a copper SFP is 1 second.

With 1+1 protection, ports on the protect card can be assigned to protect the corresponding ports on the working card. A working card must be paired with a protect card of the same type and number of ports. The protection takes place on the port level, and any number of ports on the protect card can be assigned to protect the corresponding ports on the working card.

To make the 1+1 protection scheme fully redundant, enable L2 protection for the entire VLAN ring. This enables Fast Automatic Protection Switch (FAPS). The VLAN configured on the 1+1 port must be configured as protected SVLAN.

1+1 protection can be either revertive or nonrevertive. With nonrevertive 1+1 protection, when a failure occurs and the signal switches from the working card to the protect card, the signal remains on the protect card until it is manually changed. Revertive 1+1 protection automatically switches the signal back to the working card when the working card comes back online. 1+1 protection uses trunk ports to send control traffic between working and protect cards. This trunk port connection is known as ILK trunk ports and can be provisioned via CTC.

The standby port can be configured to turn ON or OFF but the traffic coming to and from the standby port will be down. If the laser is ON at the standby port, the other end port (where traffic originates) will not be down in a parallel connection. Traffic is blocked on the standby port.

1+1 protection is bidirectional and nonrevertive by default; revertive switching can be provisioned using CTC.

## Layer 2 Over DWDM Protection

The Layer 2 Over DWDM protection is available for the following cards:

- GE\_XP and GE\_XPE
- 10GE\_XP and 10GE\_XPE

When the card is in L2-over-DWDM card mode, protection is handled by the hardware at the Layer 1 and Layer 2 levels. Fault detection and failure propagation is communicated through the ITU-T G.709 frame overhead bytes. For protected VLANs, traffic is flooded around the 10 Gigabit Ethernet DWDM ring. To set up the Layer 2 protection, you identify a node and the card port that is to serve as the primary node and port for the VLAN ring on the card view Provisioning > Protection tab. If a failure occurs, the node and port are responsible for opening and closing VLAN loops.



---

**Note** The Forced option in the Protection drop-down list converts all the SVLANs to protected SVLANs irrespective of the SVLAN protection configuration in the SVLAN database. This is applicable to a point-to-point linear topology. The SVLAN protection must be forced to move all SVLANs, including protected and unprotected SVLANs, to the protect path irrespective of provisioned SVLAN attributes.

---

A FAPS switchover happens in the following failure scenarios:

- DWDM line failures caused by a fiber cut
- Unidirectional failure in the DWDM network caused by a fiber cut
- Fiber pull on the primary card trunk port followed by a hard reset on the primary card
- Hard reset on the primary card
- Hard reset on the secondary card
- An OTN failure is detected (LOS, OTUK-LOF, OTUK-LOM, OTUK-SF, or OTUK-BDI on the DWDM receiver port in the case of ITU-T G.709 mode)
- Trunk ports are moved to OOS,DSBLD (Locked,disabled) state
- Improper removal of XFPs

A FAPS switchover does not happen in the following scenarios:

- Secondary card trunk port in OOS,DSBLD (Locked,disabled) state followed by a hard reset of the secondary card
- OTN alarms raised on the secondary card trunk port followed by a hard reset of the secondary card

## Far-End Laser Control

The cards provide a transparent mode that accurately conveys the client input signal to the far-end client output signal. The client signal is normally carried as payload over the DWDM signals. Certain client signals, however, cannot be conveyed as payload. In particular, client LOS or LOF cannot be carried. Far-end laser control (FELC) is the ability to convey an LOS or LOF from the near-end client input to the far-end client output.

If an LOS is detected on the near-end client input, the near-end trunk sets the appropriate bytes in the OTN overhead of the DWDM line. These bytes are received by the far-end trunk, and cause the far-end client laser to be turned off. When the laser is turned off, it is said to be squelched. If the near-end LOS clears, the near-end trunk clears the appropriate bytes in the OTN overhead, the far-end detects the changed bytes, and the far-end client squelch is removed.

FELC also covers the situation in which the trunk port detects that it has an invalid signal; the client is squelched so as not to propagate the invalid signal.

Payload types with the 2R mode preclude the use of OTN overhead bytes. In 2R mode, an LOS on the client port causes the trunk laser to turn off. The far end detects the LOS on its trunk receiver and squelches the client.

FELC is not provisionable. It is always enabled when the DWDM card is in transparent termination mode. However, FELC signaling to the far-end is only possible when ITU-T G.709 is enabled on both ends of the trunk span.

## Jitter Considerations

Jitter introduced by the SFPs used in the transponders and muxponders must be considered when cascading several cards. With TXP\_MR\_2.5G, TXPP\_MR\_2.5G, MXP\_MR\_2.5G, MXPP\_MR\_2.5G, TXP\_MR\_10E, 100G-LC-C, 10x10G-LC, CFP-LC, 100G-CK-C, 200G-CK-LC, 100GS-CK-LC, 100G-ME-C, 100ME-CKC, AR\_MXP, AR\_XP, AR\_XPE cards several transponders can be cascaded before the cumulative jitter violates the jitter specification. The recommended limit is 20 cards. With TXP\_MR\_10G cards, you can also cascade several cards, although the recommended limit is 12 cards. With MXP\_2.5G\_10G and MXP\_2.5G\_10E cards, any number of cards can be cascaded as long as the maximum reach between any two is not exceeded. This is because any time the signal is demultiplexed, the jitter is eliminated as a limiting factor.

The maximum reach between one transponder and the other must be halved if a Y cable is used. For more information on Y-cable operation, see the [Y-Cable and Splitter Protection](#).

## Termination Modes

Transponder and Muxponder cards have various SONET and SDH termination modes that can be configured using CTC. The termination modes are summarized in the following table.

**Table 20: Termination Modes**

Cards	Termination Mode	Description
All TXP, MXP, and OTU2_XP cards, with the exception of the MXP_2.5G_10G card (see next row)	Transparent Termination	All the bytes of the payload pass transparently through the card.
	Section Termination	In line termination mode, the section and line overhead bytes for the SDH multiplex and regenerator are terminated. None of the overhead bytes are passed through the card. All regenerated, including the SONET SDCC and line DCC (LD) and the SDH RS-DCC and multiplexer section DCC (MS-DCC).

Cards	Termination Mode	Description
MXP_2.5G_10G (Clients operating at the OC48/STM16 rate are multiplexed into an OC192/STM64 frame before going to OTN or DWDM.)	Transparent Termination	All client bytes pass transparently except the following: B1 is rewritten, A1 to A2 are regenerated, and H1 to H3 are re
	Section Termination	The SONET TOH section bytes and the SDH regenerator section bytes are terminated. None of these section overhead bytes pass through. They are all regenerated, including the SONET TOH DCC bytes and the SDH RS-DCC bytes. In the section termination mode, the SONET TOH line and SDH multiplex section overhead bytes are passed transparently.
	Line Termination	In the line termination mode, the section and line overhead bytes for SONET and the overhead bytes for the SDH multiplex and line sections are terminated. None of the overhead bytes are passed. They are all regenerated, including the SONET SDCC and MS-DCC and the SDH RS-DCC and MS-DCC bytes.

For TXP and MXP cards, adhere to the following conditions while DCC termination provisioning:

- For SDCC/RS-DCC provisioning, the card should be in the Section/RS-DCC or Line/MS-DCC termination mode.
- For LDCC/MS-DCC provisioning, the card should be in the Line/MS-DCC termination mode.

