



Alarm Propagation Scenarios

In an optical network, alarm propagation defines how different alarms propagate in a larger link during any failure in the network. The alarm correlation algorithm suppresses the lower-priority alarms on each device in the network. Hence, the network administrator can assess the health of the optical network and detect the root cause of the problem by focusing only on the significant alarms on the node.

This chapter covers the alarms that are active and suppressed during the common alarm propagation scenarios when operating the NCS 1020 chassis.

- [Unidirectional Fiber Cut on Line, on page 1](#)
- [Bidirectional Fiber Cut on Line, on page 3](#)
- [Fiber Cut Between CCMD and OLT, on page 5](#)
- [High Back Reflection Condition on Line Tx Port, on page 6](#)
- [High Back Reflection Condition on Line Rx RAMAN Port , on page 7](#)
- [High Span Loss on Line Tx Port, on page 8](#)
- [High Span Loss on Line Rx Port, on page 9](#)
- [Single Channel Failure due to Bidirectional Fiber Cut on Line, on page 10](#)
- [Single Channel Failure due to Unidirectional Fiber Cut at TXP-Tx, on page 11](#)
- [Single Channel Failure due to Unidirectional Fiber Cut at TXP-Rx, on page 12](#)

Unidirectional Fiber Cut on Line

When there is a line unidirectional fiber cut on a NCS 1020 network, alarms are raised and suppressed at the respective ports of each node.

The following figure displays line unidirectional fiber cut on a NCS 1020:

Figure 1: Unidirectional Fiber Cut on Line

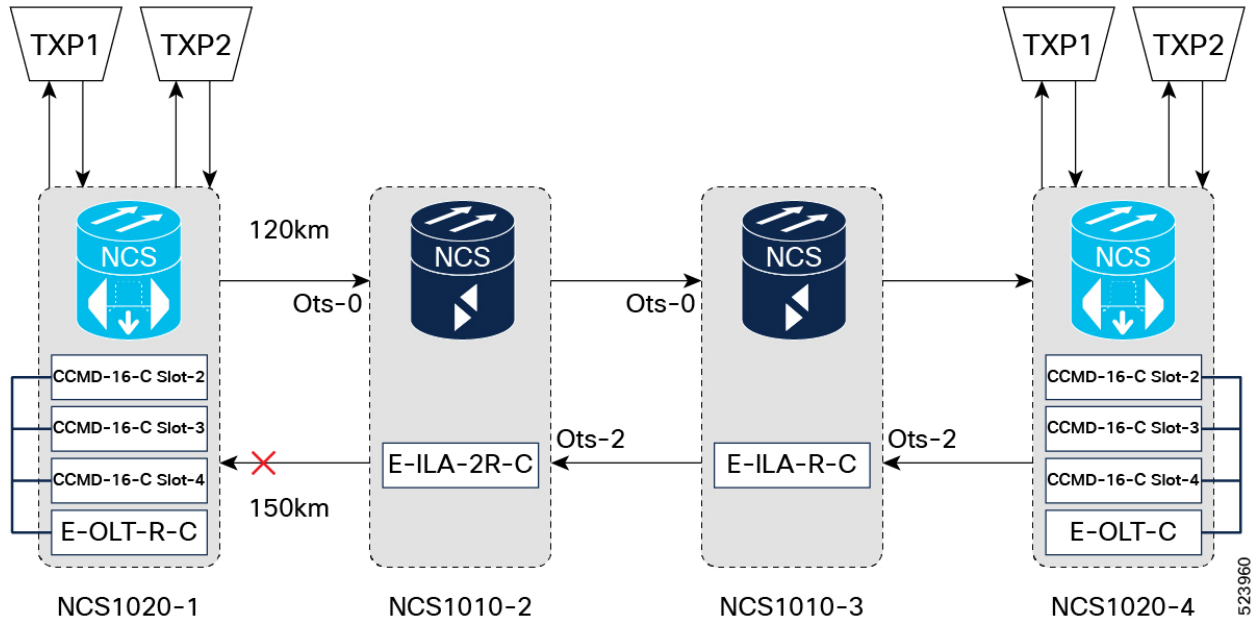

The following table lists the alarms that are raised and suppressed at the respective ports of each node:

Table 1: Active and Suppressed Alarms

NODE	Active Alarms	Ports where alarms are raised	Suppressed Alarms	Ports where alarms are suppressed
NCS 1020 - 1	<ul style="list-style-type: none"> Rx-LOC INGRESS-AUTO-LASER-SHUT EGRESS-AUTO-LASER-SHUT Raman-AUTO-LASER-SHUT APC-BLOCKED-TX APC-BLOCKED-RX RAMAN-TUNE-FAILED 	Line OTS 0/0/0/0	Rx-LOS-P	<ul style="list-style-type: none"> Line OTS 0/0/0/0 DFB 0/0/0/0 OSC 0/0/0/0 OTSOCH 0/0/0/0/x x is channel id
	TX-POWER-FAIL-LOW	OTS-OCH 0/0/0/com-port/channel	TX-POWER-FAIL-LOW	OTS-OCH 0/0/0/channel

NODE	Active Alarms	Ports where alarms are raised	Suppressed Alarms	Ports where alarms are suppressed
NCS1020 – 2 (ots - 0)	<ul style="list-style-type: none"> • Rx-LOS-P • EGRESS-AUTO-LASER-SHUT • Raman-AUTO-LASER-SHUT • APC-BLOCKED-TX • RAMAN-TUNE-FAILED 	Line OTS 0/0/0/0	Rx-LOS-P	OTS-OCH 0/0/0/0/x x is channel id
			TX-POWER-FAIL-LOW	OTS-OCH 0/0/0/0/channel
NCS1020 – 2 (ots - 2)	<ul style="list-style-type: none"> • EGRESS-AUTO-LASER-SHUT • APC-BLOCKED-TX 	Line OTS 0/0/0/2	TX-POWER-FAIL-LOW	OTS-OCH 0/0/0/2/channel
NCS1020 – 3 (ots - 0)	Rx-LOS-P	Line OTS 0/0/0/0	Rx-LOS-P	OTS-OCH 0/0/0/0/x x is channel id
NCS1020 – 3 (ots - 2)	<ul style="list-style-type: none"> • EGRESS-AUTO-LASER-SHUT • APC-BLOCKED-TX 	Line OTS 0/0/0/2	TX-POWER-FAIL-LOW	OTS-OCH 0/0/0/0/2
NCS1020 – 4	<ul style="list-style-type: none"> • INGRESS-AUTO-LASER-SHUT • APC-BLOCKED-RX • Rx-LOS-P 	Line OTS 0/0/0/0	Rx-LOS-P	OTS-OCH 0/0/0/0/x x is channel id
		TX-POWER-FAIL-LOW	OTS-OCH 0/0/0/com-port/channel	
NCS1020	Rx-LOS-P	OMS 0/0/slot/0		

Bidirectional Fiber Cut on Line

When there is a line bidirectional fiber cut on a NCS 1020 network, alarms are raised and suppressed at the respective ports of each node.

The following figure displays line bidirectional fiber cut on a NCS 1020 network:

Figure 2: Bidirectional Fiber Cut on Line

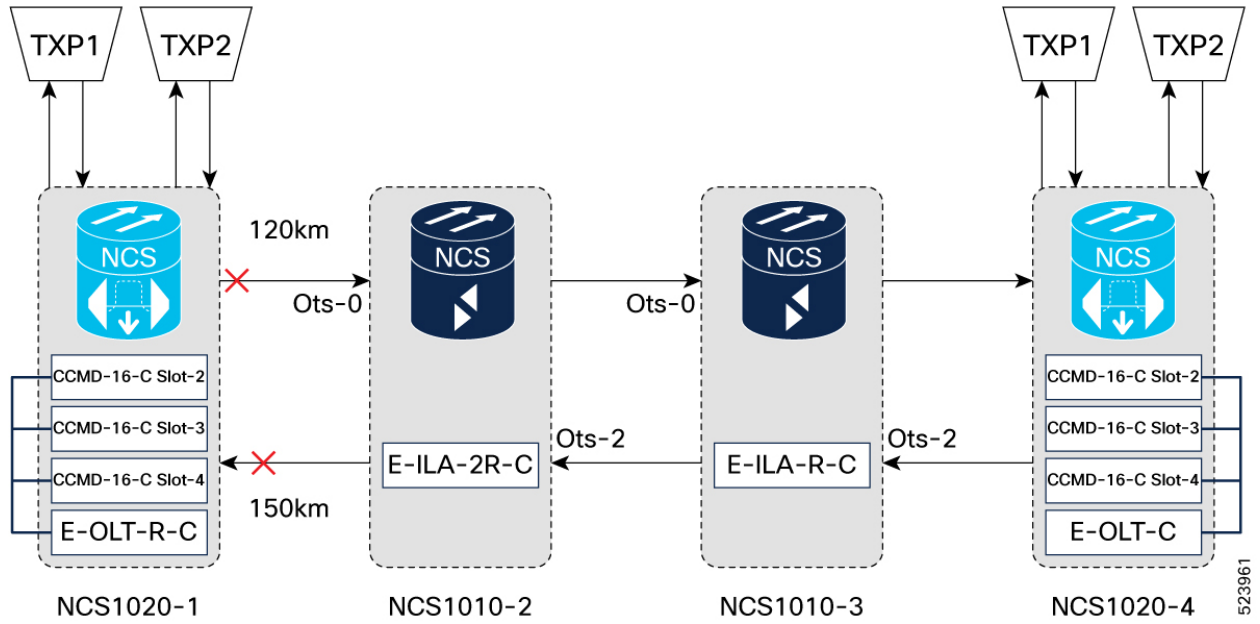

The following table lists the alarms that are raised and suppressed at the respective ports of each node:

Table 2: Active and Suppressed Alarms

NODE	Active Alarms	Ports where alarms are raised	Suppressed Alarms	Ports where alarms are suppressed
NCS1020-1	<ul style="list-style-type: none"> Rx-LOC INGRESS-AUTO-LASER-SHUT EGRESS-AUTO-LASER-SHUT Raman-AUTO-LASER-SHUT APC-BLOCKED-TX APC-BLOCKED-RX RAMAN-TUNE-FAILED 	Line OTS 0/0/0/0	Rx-LOS-P	<ul style="list-style-type: none"> Line OTS 0/0/0/0 DFB0/0/0/0 OSC0/0/0/0 OTS-OCH0000x x is channel id
	TX-POWER-FAIL-LOW	OTS-OCH 0/0/0/com-port	TX-POWER-FAIL-LOW	OTS-OCH 0/0/0/0/channel

NODE	Active Alarms	Ports where alarms are raised	Suppressed Alarms	Ports where alarms are suppressed
NCSI020 – 2 (ots - 0)	<ul style="list-style-type: none"> • Rx-LOC • EGRESS-AUTO-LASER-SHUT • Raman-AUTO-LASER-SHUT • APC-BLOCKED-TX • RAMAN-TUNE-FAILED 	Line OTS 0/0/0/0	Rx-LOS-P	<ul style="list-style-type: none"> • Line OTS 0/0/0/0 • DFB 0/0/0/0 • OSC 0/0/0/0 • OTS-OCH 0/0/0/x <p style="margin-left: 20px;">x is channel id</p>
			TX-POWER-FAIL-LOW	OTS-OCH 0/0/0/0/channel
NCSI020 – 2 (ots - 2)	<ul style="list-style-type: none"> • EGRESS-AUTO-LASER-SHUT • APC-BLOCKED-TX 	Line OTS 0/0/0/2	TX-POWER-FAIL-LOW	OTS-OCH 0/0/0/2/channel
NCSI020 – 3 (ots - 0)	Rx-LOS-P	Line OTS 0/0/0/0	Rx-LOS-P	OTS-OCH 0/0/0/0/x x is channel id
NCSI020 – 3 (ots - 2)	<ul style="list-style-type: none"> • EGRESS-AUTO-LASER-SHUT • APC-BLOCKED-TX 	Line OTS 0/0/0/2	TX-POWER-FAIL-LOW	OTS-OCH 0/0/0/2/channel
NCSI020 – 4	<ul style="list-style-type: none"> • INGRESS-AUTO-LASER-SHUT • APC-BLOCKED-RX • Rx-LOS-P 	Line OTS 0/0/0/0	Rx-LOS-P	OTS-OCH 0/0/0/0/x x is channel id
			TX-POWER-FAIL-LOW	
NCSI020	Rx-LOS-P	OMS 0/0/slot/0		

Fiber Cut Between CCMD and OLT

When a fiber cut occurs between CCMD and OLT, alarms are raised and suppressed at the respective ports of each node.

The following figure displays fiber cut between CCMD and OLT:

Figure 3: Fiber Cut Between CCMD and OLT

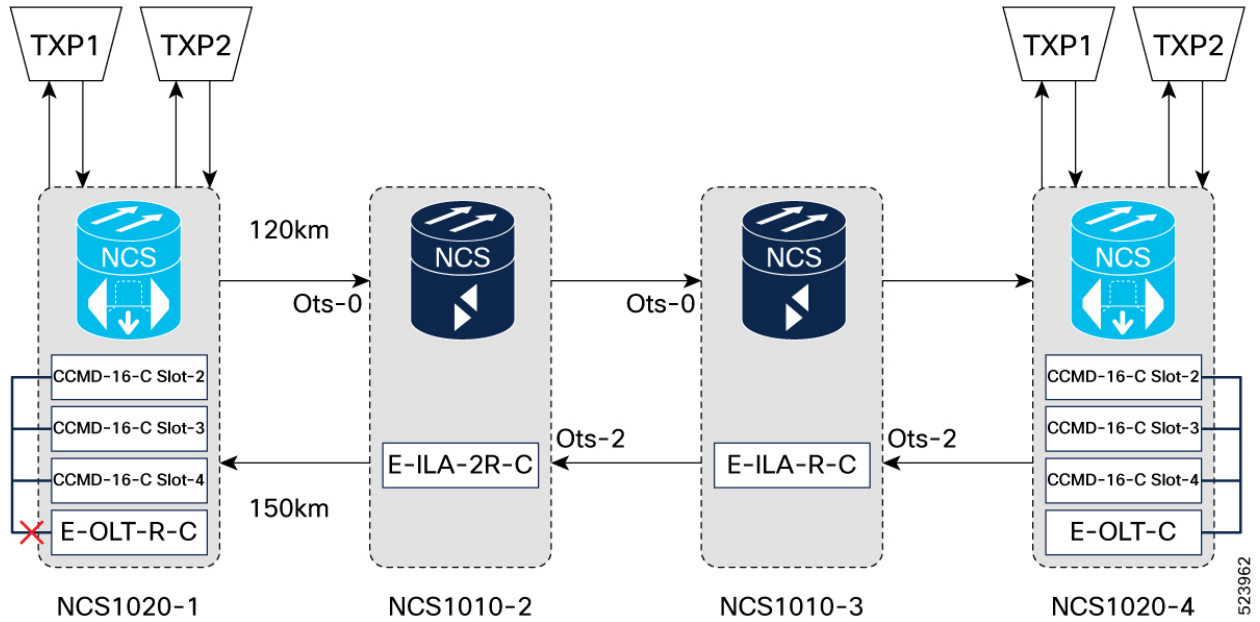

The following table lists the alarms that are raised and suppressed at the respective ports of each node:

Table 3: Active and Suppressed Alarms

Condition	NODE	Active Alarms	Ports where alarms are raised	Suppressed Alarms	Ports where alarms are suppressed
CCMD Rx Fiber Cut	NCS1020	Rx-LOS-P	OMS 0/0/slot/0		
CCMD Tx Fiber Cut	NCS1020 - 1	Rx-LOS-P	Line OTS 0/0/0/x x is a com port	Rx-LOS-P	OTS-OCH 0/0/0/x/y x is com port y is channel id
		CHANNEL-NOISE-LOADED	OTS-OCH 0/0/0/0/y y is channel id		

High Back Reflection Condition on Line Tx Port

When there is a high back reflection condition on the line Tx port, Egress EDFA goes into Automatic Power Reduction (APR) mode, and alarms are raised at the respective ports of each node.

The following figure displays high back reflection condition on the line Tx port:

Figure 4: High Back Reflection Condition on the Line Tx port

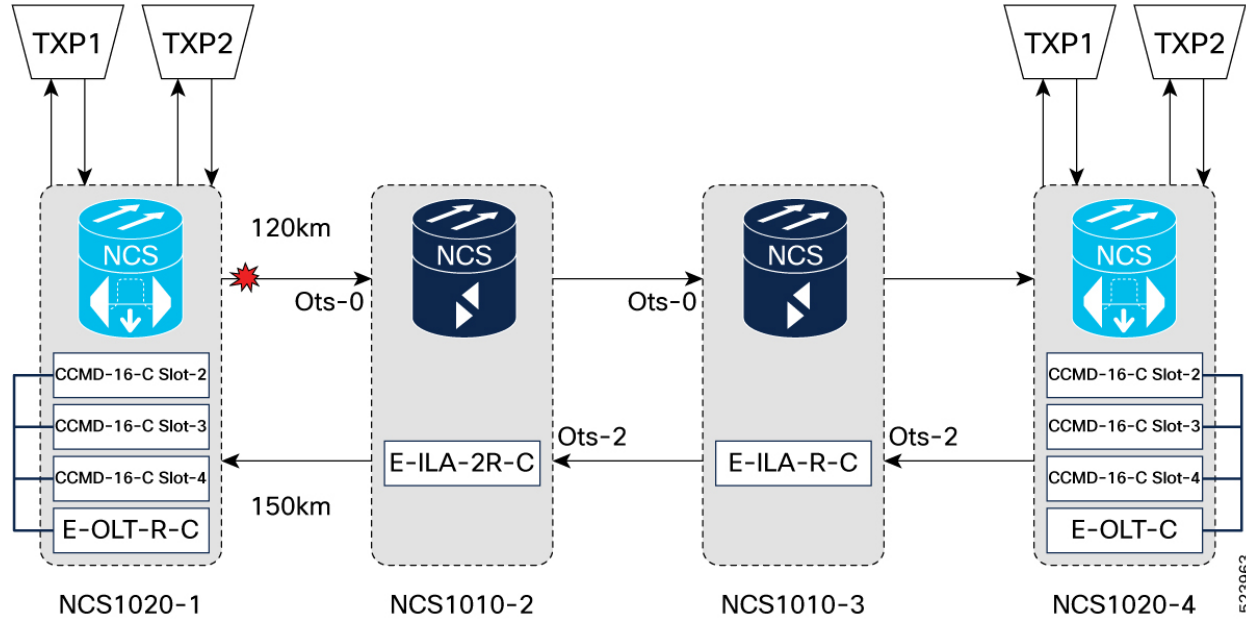

The following table lists the alarms that are raised at the respective ports of each node:

Table 4: Active Alarms

NODE	Active Alarms	Ports where alarms are raised
NCS1020 - 1	<ul style="list-style-type: none"> • TX-POWER-FAIL-LOW • High-TX-BR-PWR • APC-BLOCKED-TX 	Line OTS 0/0/0/0
NCS1020 – 2 (ots - 2)	APC-TARGET-PSD-NOT-MET-TX	Line OTS 0/0/0/2
NCS1020 – 3 (ots - 2)	APC-TARGET-PSD-NOT-MET-TX	Line OTS 0/0/0/2
NCS1020 – 4	APC-TARGET-PSD-NOT-MET-RX	Line OTS 0/0/0/0

High Back Reflection Condition on Line Rx RAMAN Port

When there is a high back reflection on the Line Rx Raman port, RAMAN pumps goes into Automatic Power Reduction (APR) mode, and alarms are raised at the respective ports of each node.

The following figure displays high back reflection condition on the line Rx RAMAN port:

Figure 5: High Back Reflection Condition on the Line Rx RAMAN Port

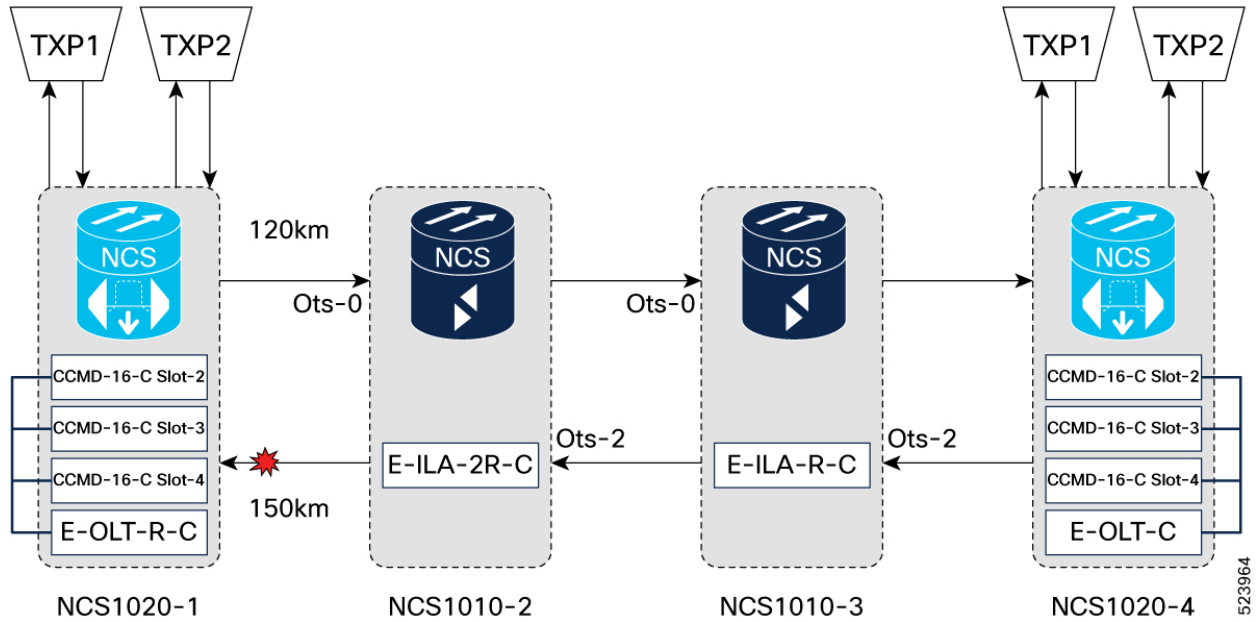

The following table lists the alarms that are raised at the respective ports of each node:

Table 5: Active Alarms

NODE	Active Alarms	Ports where alarms are raised
NCS1020	Rx-LOS-P	OMS 0/0/x/0 x is slot id
NCS1020 - 1	<ul style="list-style-type: none"> • High-RX-BR-PWR • APC-OUT-OF-RANGE-RX • RT- BLOCKED 	Line OTS 0/0/0/0

High Span Loss on Line Tx Port

When high span loss occurs on the line Tx port, alarms are raised at the respective ports of each node.

The following figure displays high span loss on line Tx port:

Figure 6: High span loss on Line Tx Port

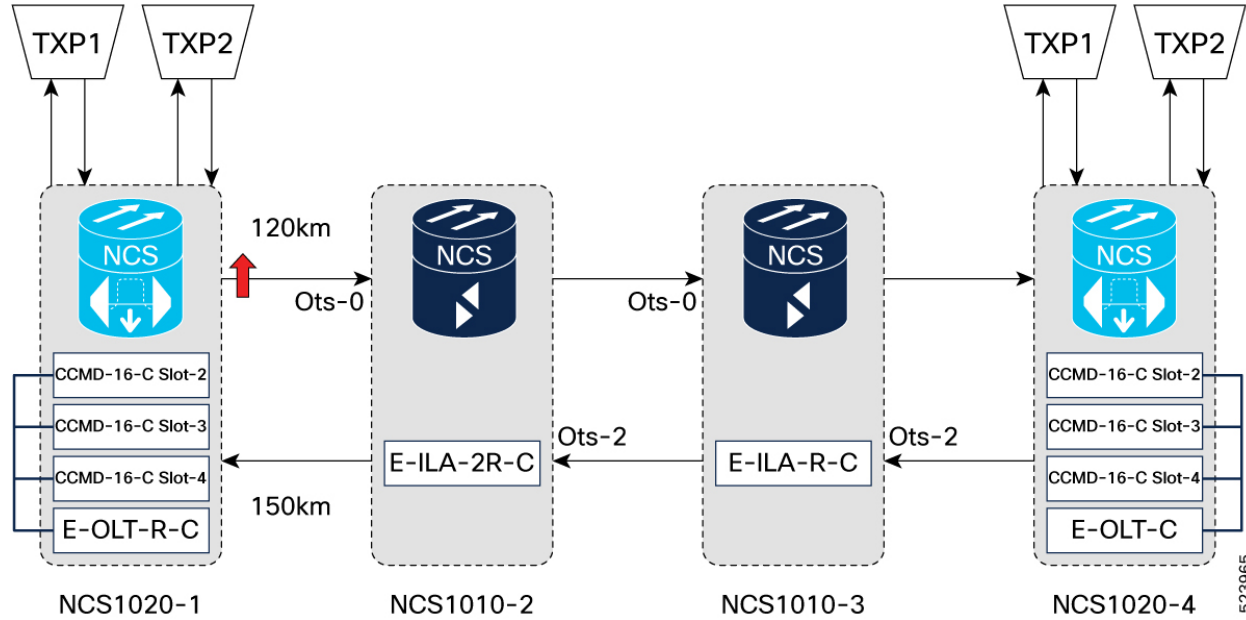

The following table lists the alarms that are raised at the line Tx port:

Table 6: Active Alarms

NODE	Active Alarms	Ports where alarms are raised
NCS1020 – 2 (ots - 0)	Span Loss Value Out Of Range	Line OTS 0/0/0/0
NCS1020 – 2 (ots - 2)	APC-OUT-OF-RANGE-TX	Line OTS 0/0/0/2

High Span Loss on Line Rx Port

When high span loss occurs on the line Rx, alarms are raised at the respective ports of each node.

The following figure displays high span loss on the line Rx port:

Figure 7: High span loss on Line Rx port

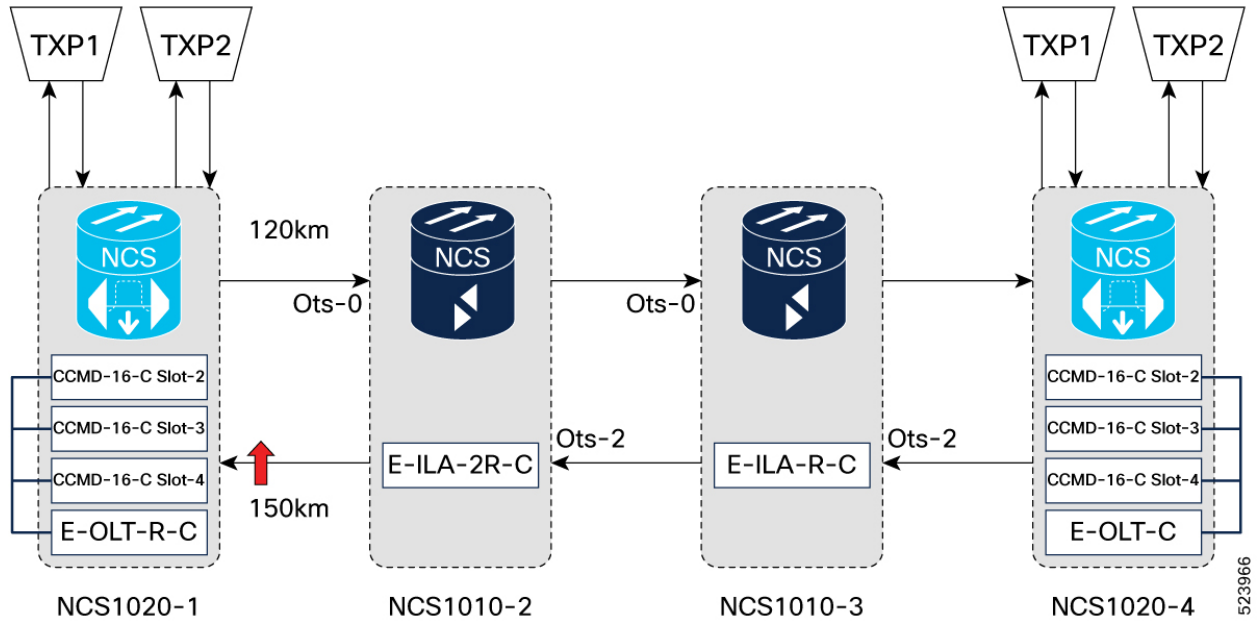

The following table lists the alarms that are raised at the line Rx port:

Table 7: Active Alarms

NODE	Active Alarms	Ports where alarms are raised
NCS1020 - 1	<ul style="list-style-type: none"> Span Loss Value Out Of Range APC-BLOCKED-RX 	Line OTS 0/0/0/0

Single Channel Failure due to Bidirectional Fiber Cut on Line

When there is a bidirectional fiber cut on the line, single channel failure occurs, and alarms are raised at each node's port.

The following figure displays single channel failure due to bidirectional fiber cut on line:

Figure 8: Single Channel Failure due to Bidirectional Fiber Cut on Line

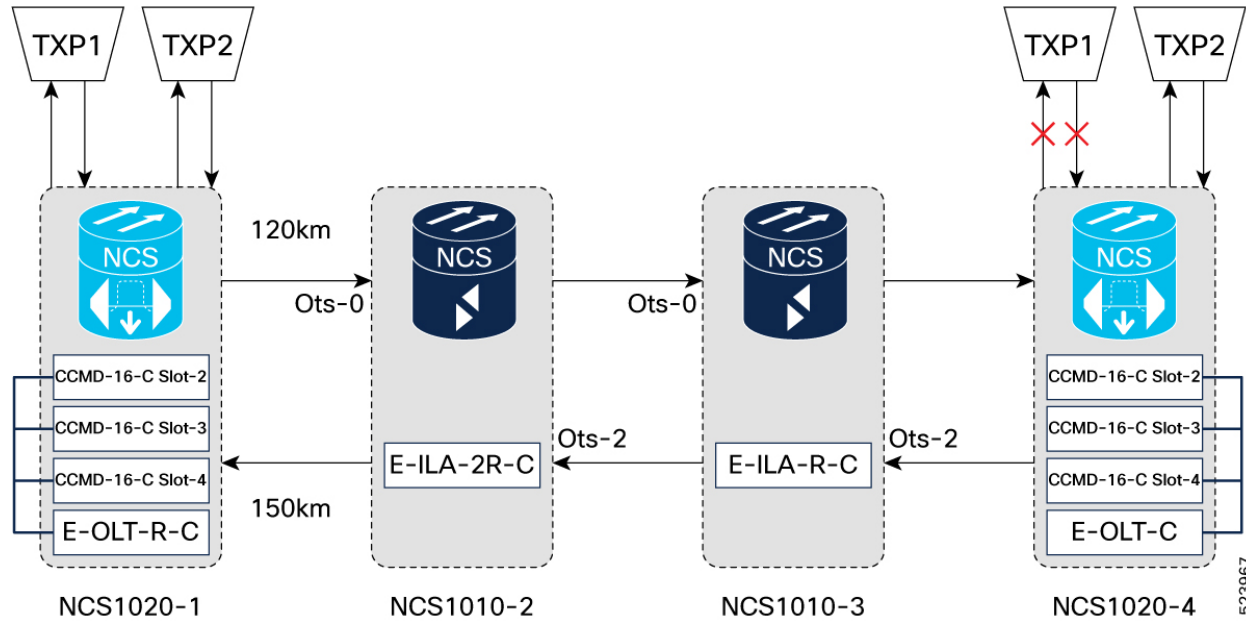

The following table lists the alarms that are raised at the respective ports of each node:

Table 8: Active Alarms

NODE	Active Alarms	Ports where alarms are raised
NCS1020 - 4	Rx-LOS-P	OTS-OCH 0/0/0/x/y x is com port y is channel number
	CHANNEL-NOISE-LOADED	OTS-OCH 0/0/0/0/y y is channel id
NCS1020 - 1	Rx-LOS-P	OCH 0/0/0/x/y x is slot id y is port number

Single Channel Failure due to Unidirectional Fiber Cut at TXP-Tx

When there is a unidirectional fiber cut at TXP-Tx, single channel failure occurs, and alarms are raised at each node's port.

The following figure displays single channel failure due to unidirectional fiber cut at TXP-Tx:

Figure 9: Single Channel Failure due to Unidirectional Fiber Cut at TXP-Tx

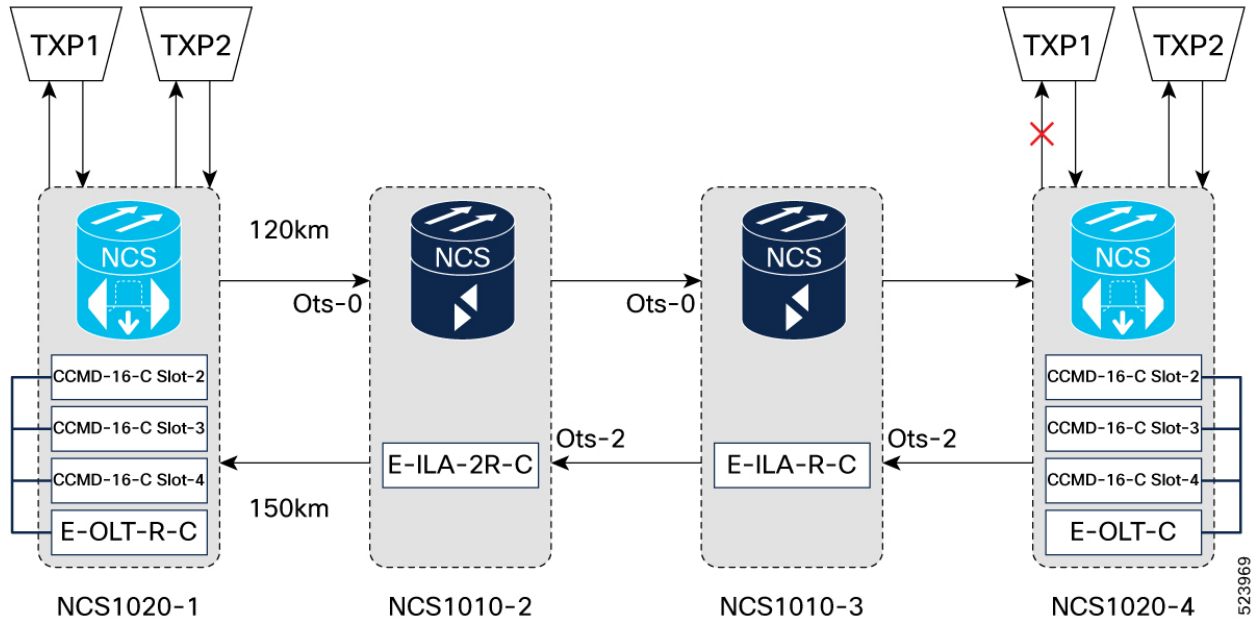

The following table lists the alarms that are raised at the respective ports of each node:

Table 9: Active Alarms

NODE	Active Alarms	Ports where alarms are raised
NCS1020 - 4	Rx-LOS-P	OTS-OCH 0/0/0/x/y x is com port y is channel number
	CHANNEL-NOISE-LOADED	OTS-OCH 0/0/0/0/y y is channel id
NCS1020	Rx-LOS-P	OCH 0/0/x/y x is slot id y is port number

Single Channel Failure due to Unidirectional Fiber Cut at TXP-Rx

When there is a unidirectional fiber cut at TXP-Rx, a single channel failure occurs, and no alarms are raised at each node's port.

The following figure displays single channel failure due to unidirectional fiber cut at TXP-Rx:

Figure 10: Single Channel Failure due to Unidirectional Fiber Cut at TXP-Tx

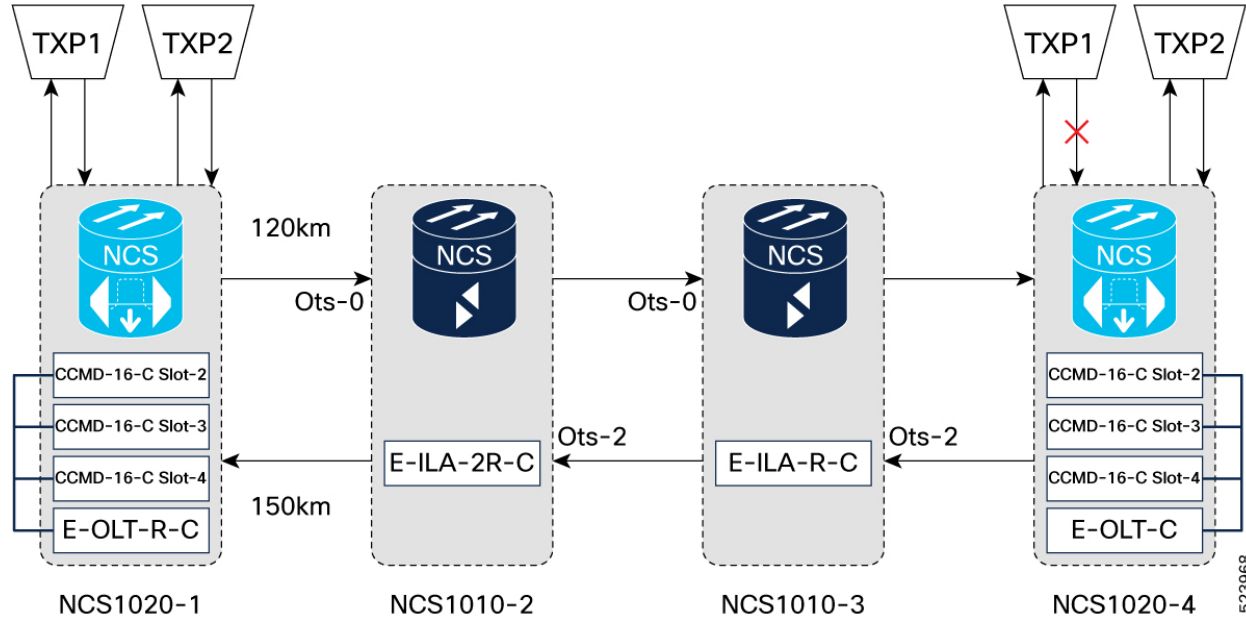

Table 10: Alarms

NODE	Active Alarms
NCS1020 - 4	No Alarm
NCS1020	No Alarm

