



Cisco NCS 1014 Advanced Multihaul Optical Platform - An Overview

This chapter provides an overview for Cisco NCS 1014 Advanced Multihaul Optical Platform.

- [Cisco NCS 1014 Chassis and Line Cards, on page 1](#)
- [Document Objective, on page 5](#)
- [Document Organization, on page 5](#)

Cisco NCS 1014 Chassis and Line Cards

The Cisco NCS 1014 chassis is an advanced multihaul optical platform supporting transponders and line system cards. It is a 2RU chassis that delivers a universal transponder solution which provides excellent performance for metro, long-haul and submarine applications.

Cisco NCS 1014 chassis has the following modules:

- Removable controller
- Removable backup solid state drive (SSD)
- Two replaceable power supply units (PSU)
- Three replaceable fan modules
- Four line cards

In Release 7.11.1, the Cisco NCS 1014 chassis supports the line cards:

- [2.4T Line Card](#)—2.4T DWDM Transponder Card
- [CCMD-16 Line Card](#)—16-port Colorless Mux/Demux Optical Line Card
- [1.2T Card](#)—1.2T DWDM Transponder Card

From Release 24.1.1, the Cisco NCS 1014 chassis supports the line cards:

- [NCS1K14-2.4T-X-K9](#)—2.4T-X DWDM Transponder/Muxponder Card
- [QXP-K9 Line Card](#)—3.2T QXP Transponder Card

1.2T Card

The 1.2T DWDM line card is a transponder that has 12 client ports to deliver 100GE and OTU4 client traffic. This line card has two trunks that operate at any rate between 100G and 600G in 50G increments. It uses Advanced Encryption Standard with a 256-bit key length (AES256)-based Layer-1 encryption to encrypt client-side data for 100GE and OTU4. The NCS1K4-1.2T-K9 line card is a single-slot unit that supports C-band traffic.

2.4T Line Card

The 2.4T line card is a coherent optics Transponder and Muxponder for the Cisco NCS 1014 chassis. It is a single-slot card that supports C-band traffic at trunk ports. This line card delivers 400GE, 100GE, and OTU4 client traffic over two trunk ports operating at speeds ranging from 400G to 1.2T each.

CCMD-16 Line Card

The CCMD-16 optical line card has:

- Two line ports to transmit and receive using the same LC connectors.
- 16 ports for add/drop with LC connector-based interfaces

There are two variants of the optical line card:

- **NCS1K14-CCMD-16-C**

The NCS1K14-CCMD-16-C line card is a C-band, 16-port Colorless Direct attach optical line card with EDFA. It can host up to 16 channels. It supports any signal distribution between 191250 and 196200 GHz, for example, the 64 channels grid with 75-GHz spacing.

- **NCS1K14-CCMD-16-L**

The NCS1K14-CCMD-16-L line card is an L-band, 16-port Colorless Direct attach optical line card with EDFA. It can host up to 16 channels. It supports any signal distribution between 186025 and 191000 GHz, for example, the 64 channels grid with 75-GHz spacing.

2.4TX Line Card

Table 1: Feature History

Feature Name	Release Information	Feature Description
NCS1K14-2.4T-X-K9 Line Card	Cisco IOS XR Release 24.1.1	<p>The new NCS1K14-2.4T-X-K9 line card is a single-slot Transponder and Muxponder card that delivers up to 1.2T C-band traffic at each trunk port. It has six QDD client ports that support 400GE and 4x100GE traffic on each port. This card provides two trunk ports that support 1.2T traffic on each port. The mxponder-slice and mxponder keywords in the hw-module command enable this card to operate in the following modes.</p> <ul style="list-style-type: none"> • Muxponder Slice Mode—The card virtually splits into two slices in this mode. It is possible to configure both trunks to carry different data rates. The supported trunk rates are 400G, 500G, 600G, 800G, 1000G, and 1200G. • Muxponder Mode—The card acts as one unit in this mode, configuring both trunks to the same data rate. The supported trunk rates are 600G and 1000G. Additionally, the capacity of a specific shared client port is consumed by two trunk ports.

The 2.4TX line card is a coherent optics Transponder and Muxponder for the Cisco NCS 1014 chassis. It is a single-slot card that supports C-band traffic at trunk ports. This card delivers 400GE and 100GE client traffic over two trunk ports operating at speeds ranging from 400G to 1.2T each. This card operates in two card modes, namely, the muxponder mode and the muxponder slice mode. In muxponder mode, the client traffic splits between the two trunk ports for 600G and 1000G payloads on port 2 and 3 respectively. In this mode, both trunk ports always carry the same data rate. In muxponder slice mode, both trunk ports act independently, carrying different data rates in each trunk.



Note In Release 24.1.1, the 2.4TX line card supports only 400, 500, 600, 800, 1000, and 1200G trunk payloads.

For more information about the 2.4TX card, see [datasheet](#).

In the 2.4TX card, the client and trunk ports support the pluggable form factor and data rates as shown in the following table.

Table 2: NCS1K14-2.4T-X-K9 Interfaces and Data Rates

Interfaces	Form Factor	Ports	Data Rates
Client	QSFP-DD56	1, 2, 3, 4, 5, 6	400G
	QSFP-DD112	2, 5	400, 800G
Trunk	Coherent Interface Module 8 (CIM8)	0, 7	up to 1.2T in each port



Note In Release 24.1.1, the ports 2 and 5 support only up to 400G data rates.

The 2.4TX card has two trunk ports and six client ports as shown in the following figure.

Figure 1: 2.4TX Line Card Front View

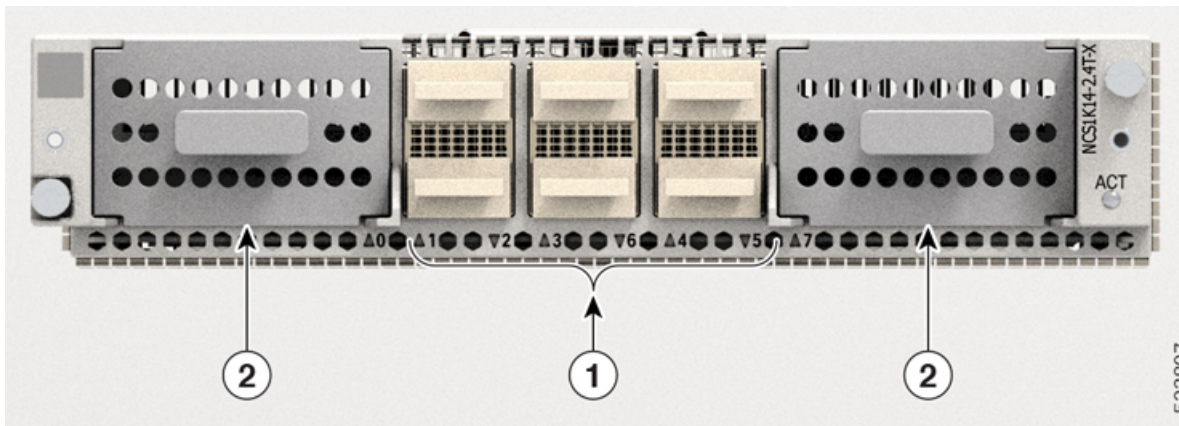

Table 3: 2.4TX Line Card Interfaces

Callout	Interface
1	Client port
2	Trunk port

The following figure shows the mapping between the client and trunk ports.

Figure 2: 2.4TX Card Client and Trunk Mapping

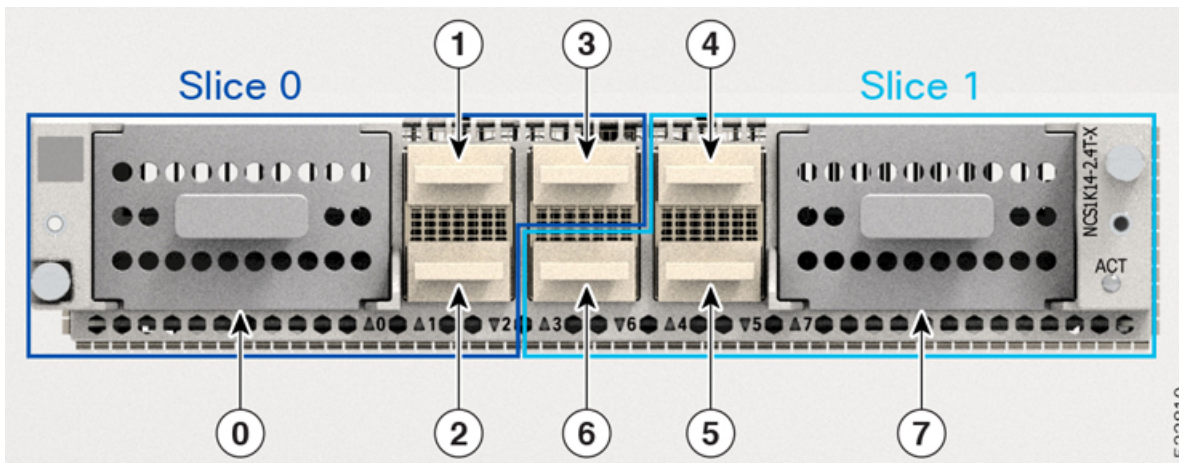

Table 4: Client-to-Trunk Port Mapping

Trunk Port	Client Ports
0	1, 2, 3
7	4, 5, 6



Note This client-to-trunk port mapping is only applicable for the mxponder-slice mode.

QXP-K9 Line Card

The QXP-K9 line card is a high-density QSFP-DD transponder that has eight client ports (QSFP-DD) and eight trunk ports (QSFP-DD ZR+). It is a single-slot card that supports 3.2T traffic through its eight QSFP-DD trunk ports. Each trunk port operates at speed up to 400G in a 50G increment. Each client port supports 400GE, 4x100GE, and 100GE without FEC client rates.

Document Objective

The Cisco NCS 1014 Configuration Guide describes how to configure various card modes for the line cards that are supported in the Cisco NCS 1014 chassis.

Document Organization

This document is organized into the following chapters:

Chapter	Description
Configuring the Card Mode	Describes different card mode configurations and supported data rates for the 1.2T, 2.4T and 2.4T-X line cards.
Performance Monitoring	Describes the configuration and retrieval of PM counters for the optics, Ethernet, coherent DSP, OCH, and OMS controller types in flex-bin, 30-second, 15-minute, or 24-hour intervals.

