



General Troubleshooting

This chapter provides procedures for troubleshooting the most common problems encountered when operating the NCS 1010 chassis.

- [Troubleshooting L Band Failure on a C+L Band Network, on page 1](#)
- [Troubleshooting C Band Failure on a C+L Band Network, on page 4](#)
- [Troubleshooting Span Failure on a C+L Band Network, on page 7](#)
- [Troubleshooting RP or LC Warm Reload on a C+L Band Network, on page 10](#)
- [Troubleshooting Client-Side Failure, on page 13](#)
- [Troubleshooting Line Port SPAN Failure, on page 15](#)
- [Troubleshooting Express Connection Failure Between Two Passive Devices, on page 18](#)
- [Troubleshooting Power Oscillation in the Network, on page 20](#)
- [Troubleshooting Connection Verification Failures, on page 21](#)

Troubleshooting L Band Failure on a C+L Band Network

In this section, we will troubleshoot L band failure due to connectivity failure between OLT-C and OLT-L nodes. To troubleshoot L-band failure on a C+L band network, start by running the following commands on the manager nodes:

Figure 1: Example of L-band Failure

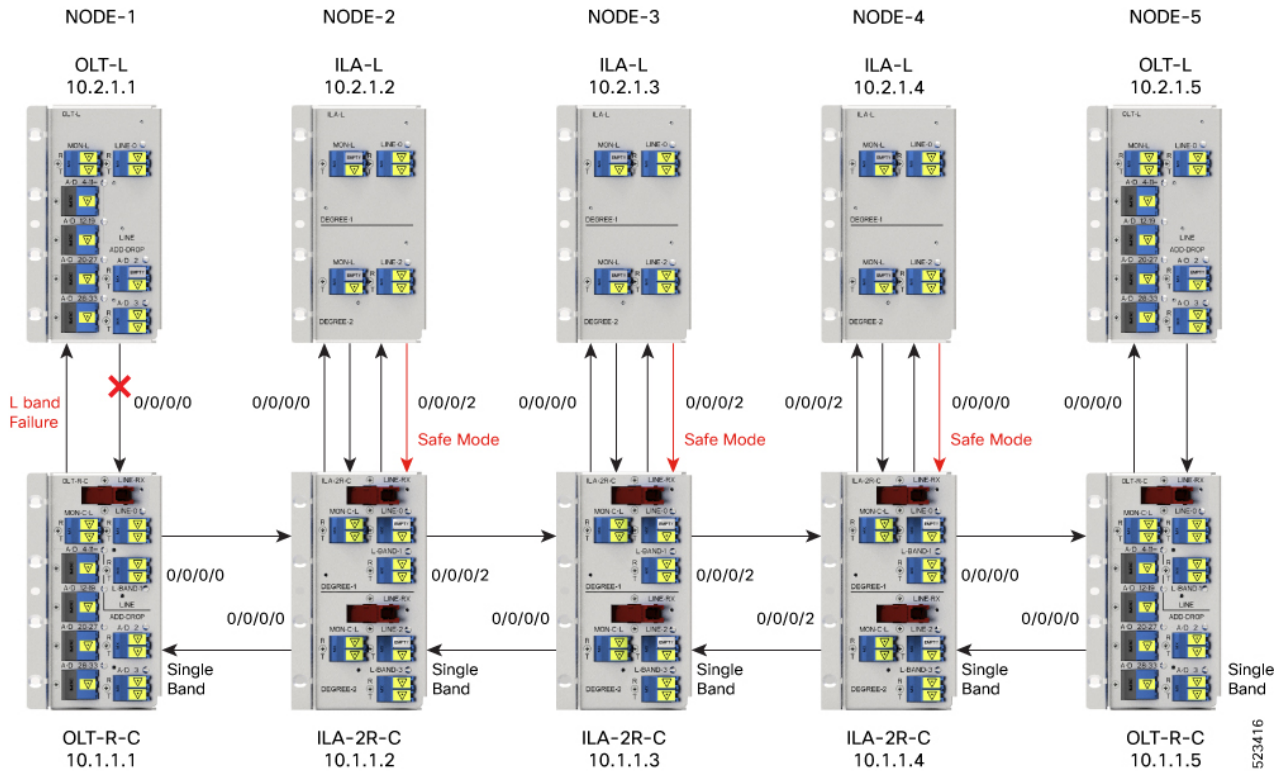

Step 1 Run the `show olc band-status` command on node 10.2.1.1.

Example:

The following command example shows the status of all the L-band nodes as FAILED which indicates that the issue is between the L-band devices of nodes 10.2.1.1 and 10.2.1.2.

```
RP/0/RP0/CPU0#show olc band-status
Fri Dec 16 03:02:07.304 UTC

Controller          : Ots0/0/0/0
Self-Band           : C-Band
BFR status          : Running

Node RID            : 10.2.1.1
Self IP Address     : 192.0.2.1
Self Controller     : Ots0/0/0/0
Partner IP address  : 192.0.2.2
Partner Controller  : Ots0/0/0/0
Partner link status : UP
C-Band status       : ACTIVE
C-Band PSD          : Single Band
L-Band status      : FAILED
L-Band PSD          : NA

Node RID            : 10.2.1.2
Self IP Address     : 198.51.100.1
Self Controller     : Ots0/0/0/0
Partner IP address  : 198.51.100.2
Partner Controller  : Ots0/0/0/2
```

```

Partner link status      : UP
C-Band status           : ACTIVE
C-Band PSD              : Single Band
L-Band status         : FAILED
L-Band PSD              : NA

Node RID                : 10.2.1.3
Self IP Address         : 203.0.113.1
Self Controller         : Ots0/0/0/0
Partner IP address      : 203.0.113.2
Partner Controller      : Ots0/0/0/2
Partner link status     : UP
C-Band status           : ACTIVE
C-Band PSD              : Single Band
L-Band status         : FAILED
L-Band PSD              : NA

Node RID                : 10.2.1.4
Self IP Address         : 209.165.200.225
Self Controller         : Ots0/0/0/0
Partner IP address      : 209.165.200.226
Partner Controller      : Ots0/0/0/0
Partner link status     : UP
C-Band status           : ACTIVE
C-Band PSD              : Single Band
L-Band status         : FAILED
L-Band PSD              : NA

```

```

Node RID                : 10.2.1.5
Self IP Address         : 209.165.201.1
Self Controller         : Ots0/0/0/0
Partner IP address      : 209.165.201.2
Partner Controller      : Ots0/0/0/0
Partner link status     : UP
C-Band status           : ACTIVE
C-Band PSD              : Single Band
L-Band status         : FAILED
L-Band PSD              : NA

```

All the network failure conditions might not reflect in the **show olc band-status** command output. Proceed to the next step to troubleshoot further.

Based on the above output, it appears that all of the C band nodes are currently active, indicating that the span has not been impacted.

Step 2 Run the **show olc apc** command on node 10.2.1.1.

Example:

The following example shows the APC status as **BLOCKED** with the *Blocked Reason* as **PARTIAL-TOPOLOGY**. As the APC manager discovers only node 10.2.1.1 and the rest nodes are not discovered. This clearly indicates that the neighbour node of 10.2.1.1 is not reachable. This indicates hence connectivity failure is between the OLT-C node 10.1.1.1 and OLT-L node 10.1.1.2.

```

RP/0/RP0/CPU0:P1BL_DT_07#show olc apc
Mon Dec 26 09:32:23.624 UTC

Controller              : Ots0/0/0/0
APC Status              : BLOCKED
Blocked Reason       : [ PARTIAL-TOPOLOGY NODE-BLOCKED ]

Node RID                : 10.2.1.1

```

```
Internal State : BLOCKED
Blocked Reason : [ AMPLI-SHUT ]
```

Step 3 Run the **show alarms brief system active** command.

Example:

The following example shows the *Loss Of Continuity* alarm which confirms the fiber failure between the the OLT-L node 10.2.1.1 and ILA-L node 10.2.1.2.

```
RP/0/RP0/CPU0:P1BL_DT_07#show alarms brief system active
```

```
0/0/NXR0      Minor      Software      12/26/2022 09:27:47 UTC    Ots0/0/0/0 - APC Partial
topology

0/0           Major      Ethernet      12/26/2022 09:27:47 UTC    GigabitEthernet0/0/0/0 -
Loss of Synchronization The Data Interface

0/0/NXR0      Minor      Software      12/26/2022 09:32:15 UTC    Ots0/0/0/0 - APC blocked

0/0           Critical   Controller    12/26/2022 09:32:16 UTC    Ots0/0/0/0 - Loss Of Continuity

0/0           Not Alarmed Controller    12/26/2022 09:32:16 UTC    Ots0/0/0/0 - Egress Amplifier
OFF for Safety Reasons
```

Hence, from steps 2 and 3 outputs, we can conclude that the connectivity failure is between the OLT-L node 10.2.1.1 and ILA-L node 10.2.1.2, and the *Loss Of Continuity* alarm confirms the fiber failure between the nodes 10.2.1.1 and 10.2.1.2.

Troubleshooting C Band Failure on a C+L Band Network

In this section, we will troubleshoot C band failure due to amplifier shutdown or failure. To troubleshoot C-band failure on a C+L band network, start by running the following commands on the manager nodes in the same order:

Figure 2: Example of C-band Failure on a C+L Band Network

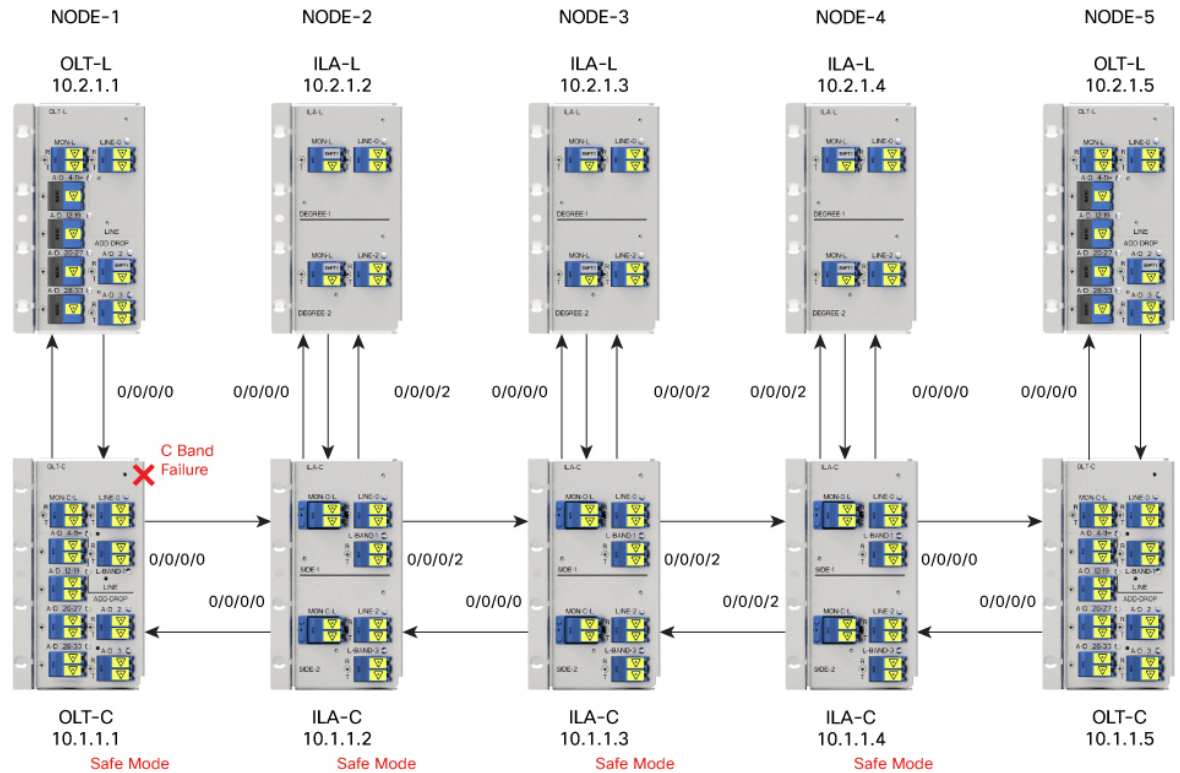

523164

Step 1 Run the `show olc band-status` command on node 10.1.1.1.

Example:

The following command example shows the status of all the C-band nodes as FAILED which indicates that the issue is between the C-band devices of nodes 10.1.1.1 and 10.1.1.2.

```
RP/0/RP0/CPU0:#sh olc band-status
Tue Feb  7 13:37:38.618 UTC

Controller          : Ots0/0/0/0
Self-Band           : C-Band
BFR status          : Running

Node RID            : 10.1.1.1
Self IP address     : 10.9.1.1
Self Controller     : Ots0/0/0/0
Partner IP address  : 192.0.2.1
Partner Controller  : Ots0/0/0/0
Partner link status : UP
C-Band status      : FAILED
C-Band PSD          : NA
L-Band status       : ACTIVE
L-Band PSD          : Single Band

Node RID            : 10.1.1.2
Self IP address     : 192.0.2.8
Self Controller     : Ots0/0/0/2
Partner IP address  : 192.0.2.2
Partner Controller  : Ots0/0/0/2
```

```

Partner link status      : UP
C-Band status         : FAILED
C-Band PSD              : NA
L-Band status           : ACTIVE
L-Band PSD              : Single Band

Node RID                 : 10.1.1.3
Self IP address         : 198.51.100.1
Self Controller         : Ots0/0/0/2
Partner IP address      : 192.0.2.3
Partner Controller      : Ots0/0/0/2
Partner link status     : UP
C-Band status         : FAILED
C-Band PSD              : NA
L-Band status           : ACTIVE
L-Band PSD              : Single Band

Node RID                 : 10.1.1.4
Self IP address         : 203.0.113.1
Self Controller         : Ots0/0/0/0
Partner IP address      : 192.0.2.4
Partner Controller      : Ots0/0/0/0
Partner link status     : UP
C-Band status         : FAILED
C-Band PSD              : NA
L-Band status           : ACTIVE
L-Band PSD              : Single Band

Node RID                 : 10.1.1.5
Self IP address         : 209.165.200.225
Self Controller         : Ots0/0/0/0
Partner IP address      : 192.0.2.5
Partner Controller      : Ots0/0/0/0
Partner link status     : UP
C-Band status         : FAILED
C-Band PSD              : NA
L-Band status           : ACTIVE
L-Band PSD              : Single Band

```

All the network failure conditions might not reflect in the **show olc band-status** command output. Proceed to the next step to troubleshoot further.

Step 2 Run the **show olc apc** command on node 10.1.1.1.

Example:

The following command output shows APC status of Manager node as NODE-BLOCKED. As the APC manager shows the *Blocked Reason* of the agent node 10.1.1.1 as AMPLI-SHUT, it clearly indicates that amplifier is set to OFF state between the manager node 10.1.1.1 and the agent node 10.1.1.2.

```

RP/0/RP0/CPU0:# show olc apc
Tue Feb  7 13:37:40.146 UTC

Controller      : Ots0/0/0/0
APC Status      : BLOCKED
Blocked Reason  : [ NODE-BLOCKED ]

Node RID        : 10.1.1.1
Internal State  : BLOCKED
Blocked Reason  : [ AMPLI-SHUT ]

Node RID        : 10.1.1.2
Internal State  : BLOCKED
Blocked Reason  : [ BAND-FAILURE ]

```

```
Node RID      : 10.1.1.3
Internal State : BLOCKED
Blocked Reason : [ BAND-FAILURE ]

Node RID      : 10.1.1.4
Internal State : BLOCKED
Blocked Reason : [ BAND-FAILURE ]

Node RID      : 10.1.1.5
Internal State : BLOCKED
Blocked Reason : [ AMPLI-SHUT ]
```

Step 3 Run the **show alarms brief system active** command.

Example:

The following example shows APC output as BLOCKED but without any partial topology alarm which indicates that the span is intact.

```
RP/0/RP0/CPU0:#show alarms b s a
```

```
0/0/NXR0      Minor      Software      02/07/2023 13:37:16 UTC      Ots0/0/0/0 - APC blocked
```

Based on the analysis of steps 2 and 3 we can conclude that the amplifier between the manager node 10.1.1.1 and the agent node 10.1.1.2 is shut down which has caused the C-band 10.1.1.1 to fail.

Troubleshooting Span Failure on a C+L Band Network

To troubleshoot span failure on a C+L band network, start by running the following commands on the manager nodes in the same order:

Figure 3: Example of Span Failure

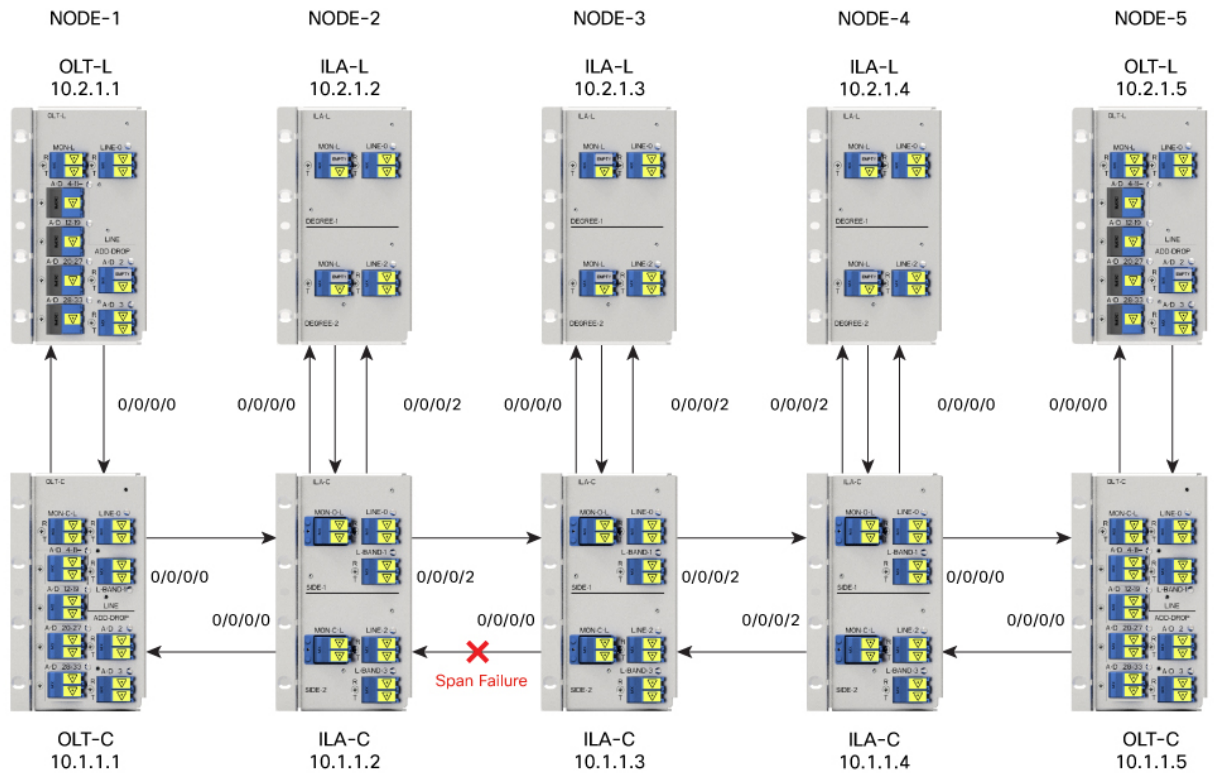

523166

Step 1 Run the `show olc band-status` command on node 10.1.1.1.

Example:

The following command output shows that the C and L-band devices from the nodes 10.1.1.2 to 10.1.1.5 are FAILED, there is a possibility of span failure.

```
RP/0/RP0/CPU0:#sh olc band-status
Tue Feb  7 13:55:21.265 UTC

Controller          : Ots0/0/0/0
Self-Band           : C-Band
BFR status          : Running

Node RID            : 10.1.1.1
Self IP Address     : 192.0.2.1
Self Controller     : Ots0/0/0/0
Partner IP address  : 192.0.2.2
Partner Controller  : Ots0/0/0/0
Partner link status : UP
C-Band status       : ACTIVE
C-Band PSD          : Dual Band
L-Band status       : ACTIVE
L-Band PSD          : Dual Band

Node RID            : 10.1.1.2
Self IP address     : 198.51.100.1
Self Controller     : Ots0/0/0/2
Partner IP address  : 198.51.100.2
Partner Controller  : Ots0/0/0/2
```



```

Partner link status      : UP
C-Band status         : FAILED
C-Band PSD              : NA
L-Band status         : FAILED
L-Band PSD              : NA

Node RID                : 10.1.1.3
Self IP address         : 203.0.113.1
Self Controller         : Ots0/0/0/2
Partner IP address      : 203.0.113.2
Partner Controller      : Ots0/0/0/2
Partner link status     : NA
C-Band status         : FAILED
C-Band PSD              : NA
L-Band status         : FAILED
L-Band PSD              : NA

Node RID                : 10.1.1.4
Self IP address         : 209.165.200.225
Self Controller         : Ots0/0/0/0
Partner IP address      : 209.165.200.226
Partner Controller      : Ots0/0/0/0
Partner link status     : NA
C-Band status         : FAILED
C-Band PSD              : NA
L-Band status         : FAILED
L-Band PSD              : NA

Node RID                : 10.1.1.5
Self IP address         : 209.165.201.1
Self Controller         : Ots0/0/0/0
Partner IP address      : 209.165.201.2
Partner Controller      : Ots0/0/0/0
Partner link status     : NA
C-Band status         : FAILED
L-Band status         : FAILED

```

All the network failure conditions might not reflect in the **show olc band-status** command output. Proceed to the next step to troubleshoot further.

Step 2 Run the **show olc apc** command on node 10.1.1.1.

Example:

The following command output shows the APC status as BLOCKED with the reason as PARTIAL-TOPOLOGY on both C and L-band OLT devices. This indicates that there is a span failure.

```

RP/0/RP0/CPU0:# show olc apc

Controller      : Ots0/0/0/0
APC Status      : BLOCKED
Blocked Reason  : [ PARTIAL-TOPOLOGY  NODE-BLOCKED ]

Node RID        : 10.1.1.1
Internal State  : IDLE

Node RID        : 10.1.1.2
Internal State  : BLOCKED
Blocked Reason  : [ AMPLI-SHUT ]

```

Step 3 Run the **show alarms brief system active** command.

Example:

The following example shows the *Loss Of Signal* alarm which confirms the span failure.

```
RRP/0/RP0/CPU0:3#sh alarms breif system active
```

0/0/NXR0 topology	Minor	Software	02/07/2023 13:52:44 UTC	Ots0/0/0/0 - APC Partial
0/0/NXR0	Minor	Software	02/07/2023 14:01:39 UTC	Ots0/0/0/0 - APC blocked
0/0 - Payload	Critical	Controller	02/07/2023 13:55:00 UTC	Ots0/0/0/0 - Loss of Signal

Hence, from steps 2 and 3 outputs, we can conclude that the PARTIAL-TOPOLOGY status on the OLT devices and the *Loss Of Signal* alarm confirmed the span failure.

Troubleshooting RP or LC Warm Reload on a C+L Band Network

On a C+L band network, RP or LC warm reload on a C or L band device might affect the partner band connectivity. In this case, traffic is not impacted. To troubleshoot a RP or LC warm reload on a C+L band network, following these steps:

Figure 4: Example RP or LC Warm Reload Troubleshooting on C+L Band Network

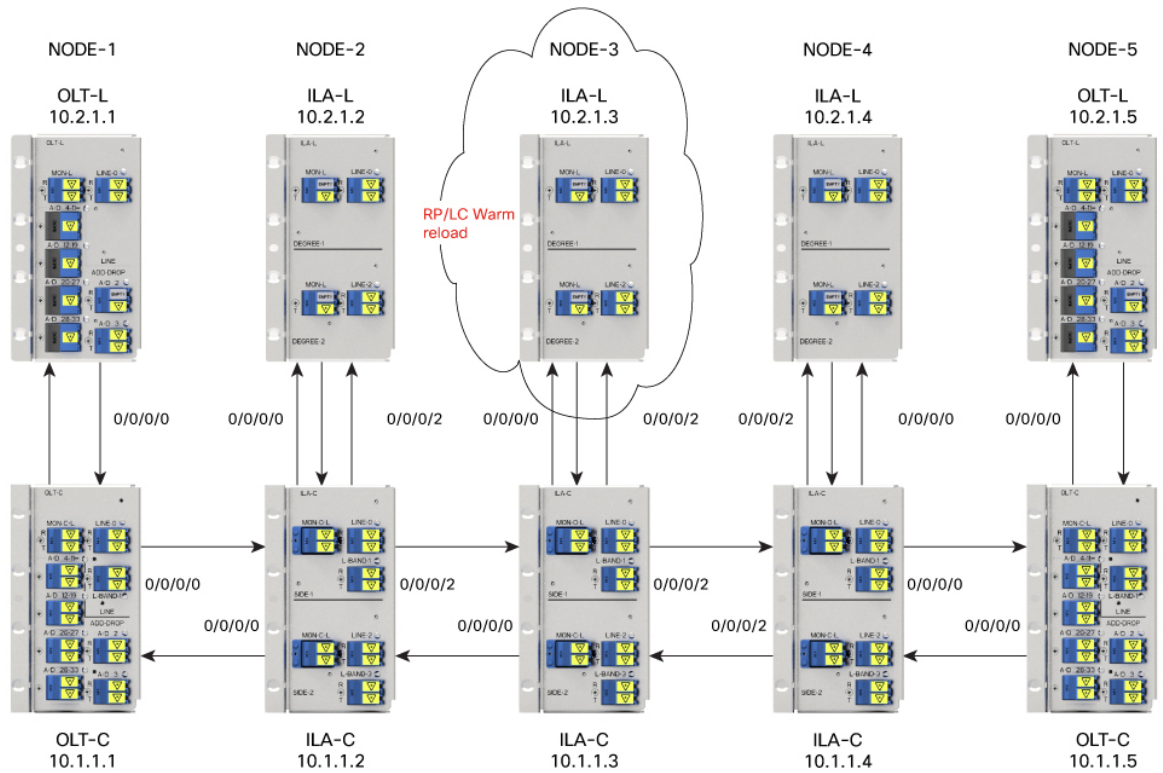

523165

Step 1 Run the **show olc band-status** command on node 10.1.1.1.

Example:

The following example shows the *Partner link status* at node 10.1.1.3 is DOWN. *Partner link status* can be down due to communication failure between C and L-band devices at the node which can be due to RP reload, power cycle event or LC cold reload.

```
RP/0/RP0/CPU0:#sh olc band-status
Tue Feb  7 14:14:40.933 UTC

Controller           : Ots0/0/0/0
Self-Band            : C-Band
BFR status           : Running

Node RID             : 10.1.1.1
Self IP address      : 192.0.2.1
Self Controller      : Ots0/0/0/0
Partner IP address   : 198.51.100.2
Partner Controller   : Ots0/0/0/0
Partner link status  : UP
C-Band status        : ACTIVE
C-Band PSD           : Dual Band
L-Band status        : ACTIVE
L-Band PSD           : Dual Band

Node RID             : 10.1.1.2
Self IP address      : 192.0.2.2
Self Controller      : Ots0/0/0/2
Partner IP address   : 198.51.100.1
Partner Controller   : Ots0/0/0/2
Partner link status  : UP
C-Band status        : ACTIVE
C-Band PSD           : Dual Band
L-Band status        : ACTIVE
L-Band PSD           : Dual Band

Node RID             : 10.1.1.3
Self IP address      : 192.0.2.3
Self Controller      : Ots0/0/0/2
Partner IP address   : 203.0.113.1
Partner Controller   : Ots0/0/0/2
Partner link status : DOWN
C-Band status        : ACTIVE
C-Band PSD           : Dual Band
L-Band status        : ACTIVE
L-Band PSD           : Dual Band

Node RID             : 10.1.1.4
Self IP address      : 192.0.2.4
Self Controller      : Ots0/0/0/0
Partner IP address   : 209.165.200.225
Partner Controller   : Ots0/0/0/0
Partner link status  : UP
C-Band status        : ACTIVE
C-Band PSD           : Dual Band
L-Band status        : ACTIVE
L-Band PSD           : Dual Band

Node RID             : 10.1.1.5
Self IP address      : 192.0.2.5
Self Controller      : Ots0/0/0/0
```

```

Partner IP address      : 209.165.201.1
Partner Controller     : Ots0/0/0/0
Partner link status    : UP
C-Band status          : ACTIVE
L-Band status          : ACTIVE

```

All the network failure conditions might not reflect in the **show olc band-status** command output. Proceed to the next step to troubleshoot further.

To investigate further, run the command in step 2.

Step 2 Run the **show olc apc** command on node 10.1.1.1 and 10.2.1.1.

Example:

The following command example on node 10.1.1.1 shows APC status on OLT-C device as IDLE as the APC manager discovers all the C-band nodes. This clearly indicates all the C-Band nodes are active.

```

RP/0/RP0/CPU0:#show olc apc

Controller      : Ots0/0/0/0
APC Status      : IDLE

Node RID        : 10.1.1.1
Internal State  : IDLE

Node RID        : 10.1.1.2
Internal State  : IDLE

Node RID        : 10.1.1.3
Internal State  : IDLE

Node RID        : 10.1.1.4
Internal State  : IDLE

Node RID        : 10.1.1.5
Internal State  : IDLE

```

Example:

The following command example on 10.2.1.1 shows APC manager discovers only nodes 10.2.1.1 and 10.2.1.2. This indicates that the L-Band device 10.2.1.3 is not reachable to the manager node 10.2.1.1.

```

RP/0/RP0/CPU0:#show olc apc
Tue Feb  7 14:16:46.264 UTC

Controller      : Ots0/0/0/0
APC Status      : BLOCKED
Blocked Reason  : [ PARTIAL-TOPOLOGY ]

Node RID        : 10.2.1.1
Internal State  : IDLE

Node RID        : 10.2.1.2
Internal State  : IDLE

```

Step 3 Run the **show alarms brief system active** command on 10.2.1.1.

Example:

The following command example shows the *Node is unpaired from band partner node* alarm which confirms connection between node 10.2.1.3 is not paired with 10.1.1.3.

```

RP/0/RP0/CPU0:P1BL_DT_07#show alarms brief system active

```

```
RP/0/RP0/CPU0:P1BL_DT_07#show alarms brief system active      0/0/NXR0      NotAlarmed   Software
02/07/2023 14:13:01 UTC      Node is unpaired from band partner node
```

The analysis of steps 2 and 3 confirm that node 10.2.1.3 is not available due to RP or LC warm reload.

Troubleshooting Client-Side Failure

Problem

This problem occurs when there is a signal payload loss in the following conditions:

- If the fiber cut occurs at the client-side in the direction from the client to the NCS 1010, the LOS-P alarm is raised at the AD port controller OTS.
- If the fiber cut occurs at the client-side in the direction from the NCS 1010 to the client, the LOS-P alarm is raised at the Passive device controller OMS.

Topology and Components

To build this topology, you need the following hardware:

- Cisco NCS 1010 devices
- NCS1K-MD32E-C modules
- NCS1K-MD32O-C modules
- NCS1K-BRK-24 modules
- QDD-400G-ZR-S transceiver

The following figure displays client-side failure due to fiber cut:

Figure 5: Fiber Cut at the AD Port OTS Controller and OMS Controller

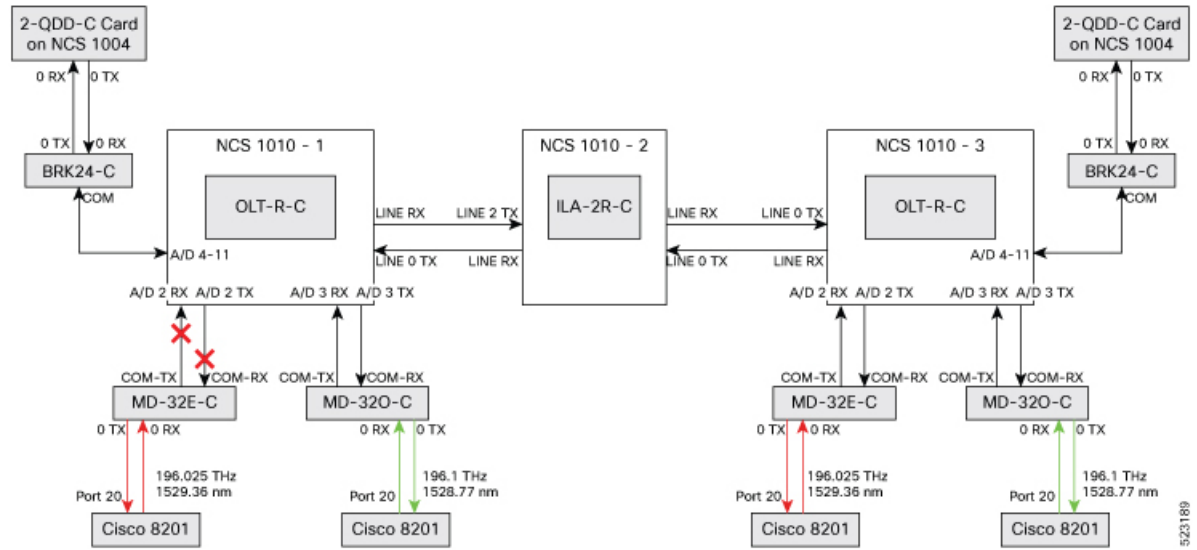

Example 1

The following example shows how to determine LOS-P failure at the AD port controller OTS:

```
RP/0/RP0/CPU0:ios#show controllers ots0/0/0/3
Tue Mar 28 15:58:12.210 UTC

Controller State: Down

Transport Admin State: Automatic In Service

LED State: Red
```

```
Alarm Status:
-----
Detected Alarms:
    RX-LOS-P

Alarm Statistics:
-----
RX-LOS-P = 2
RX-LOC = 0
TX-POWER-FAIL-LOW = 0
INGRESS-AUTO-LASER-SHUT = 0
INGRESS-AUTO-POW-RED = 0
INGRESS-AMPLI-GAIN-LOW = 0
INGRESS-AMPLI-GAIN-HIGH = 0
EGRESS-AUTO-LASER-SHUT = 0
EGRESS-AUTO-POW-RED = 0
EGRESS-AMPLI-GAIN-LOW = 0
EGRESS-AMPLI-GAIN-HIGH = 0
HIGH-TX-BR-PWR = 0
HIGH-RX-BR-PWR = 0
SPAN-TOO-SHORT-TX = 0
SPAN-TOO-SHORT-RX = 0

Parameter Statistics:
-----
```

```
Total Rx Power = -50.00 dBm
Total Tx Power = -50.00 dBm
Ingress Ampli Mode = Gain
Ingress Ampli Gain = 0.0 dB
Ingress Ampli Tilt = 0.0 dB
```

```
Configured Parameters:
```

```
-----
Ingress Ampli Mode = Gain
Ingress Ampli Gain = 16.0 dB
Ingress Ampli Power = -3.0 dBm
Ingress Ampli Tilt = 0.0 dB
Rx Low Threshold = -3276.8 dBm
Tx Low Threshold = -3276.8 dBm
```

Example 2

The following example shows how to determine LOS-P failure at the passive device controller OMS:

```
RP/0/RP0/CPU0:P2A_DT_07#sh controllers oms 0/1/0/8
Tue Mar 28 16:00:33.685 UTC
```

```
Controller State: Down
```

```
Transport Admin State: Automatic In Service
```

```
LED State: Red
```

```
Alarm Status:
```

```
-----
Detected Alarms:
```

```
    RX-LOS-P
```

```
Alarm Statistics:
```

```
-----
RX-LOS-P = 1
TX-POWER-FAIL-LOW = 0
```

```
Parameter Statistics:
```

```
-----
Tx Power = -50.00 dBm
Rx Power = -50.00 dBm
```

Solution

See [RX-LOS-P](#) to resolve this alarm.

Troubleshooting Line Port SPAN Failure

Problem

This problem occurs when there is a loss of fiber connection at the Line port due to fiber cut. As a result, the LOC alarm is raised at the Line OTS controller.

Topology and Components

To build this point-to-point topology, you need the following hardware:

- Cisco NCS 1010 devices
- NCS1K-MD32E-C modules
- NCS1K-MD32O-C modules
- QDD-400G-ZR-S transceiver

The following figure shows loss of fiber connection continuity at the Line port:

Figure 6: Fiber Cut at the Line OTS Controller

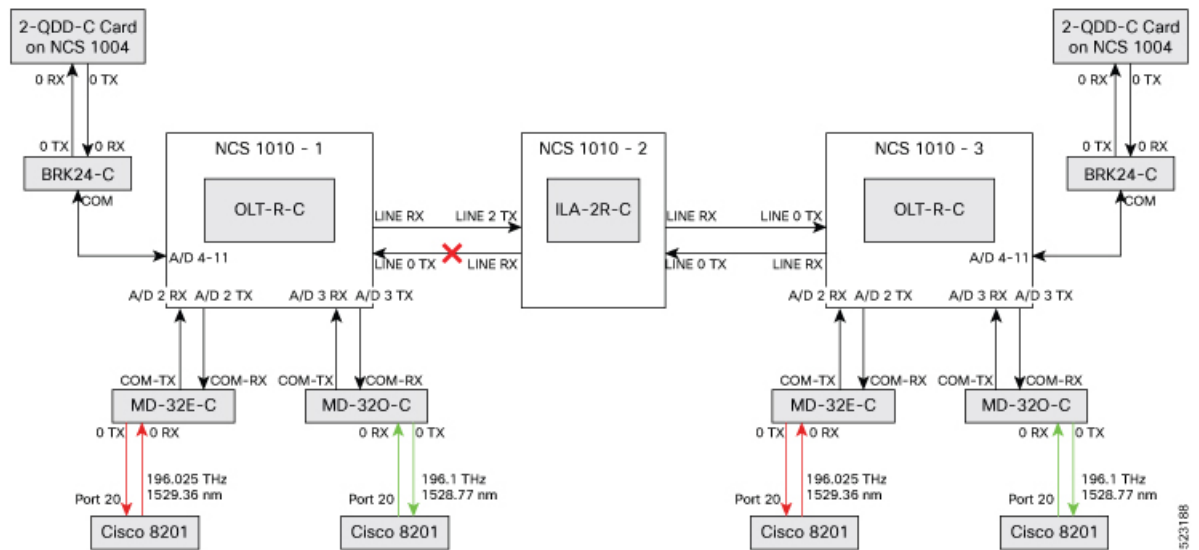

Example 1

The following example shows how to determine a span failure.

```
RP/0/RP0/CPU0:ios#show controllers ots0/0/0/0
Tue Mar 28 15:48:31.486 UTC
```

```
Controller State: Down
```

```
Transport Admin State: In Service
```

```
LED State: Red
```

Alarm Status:

Detected Alarms:

```
RX-LOS-P
RX-LOC
EGRESS-AUTO-LASER-SHUT
```

Alarm Statistics:

```
RX-LOS-P = 2
RX-LOC = 2
```



```
TX-POWER-FAIL-LOW = 3
INGRESS-AUTO-LASER-SHUT = 0
INGRESS-AUTO-POW-RED = 0
INGRESS-AMPLI-GAIN-LOW = 0
INGRESS-AMPLI-GAIN-HIGH = 0
EGRESS-AUTO-LASER-SHUT = 2
EGRESS-AUTO-POW-RED = 0
EGRESS-AMPLI-GAIN-LOW = 0
EGRESS-AMPLI-GAIN-HIGH = 0
HIGH-TX-BR-PWR = 0
HIGH-RX-BR-PWR = 0
SPAN-TOO-SHORT-TX = 0
SPAN-TOO-SHORT-RX = 0
```

Parameter Statistics:

```
-----
Total Rx Power(C+L) = 10.69 dBm
Total Tx Power(C+L) = 19.50 dBm
Total Rx Power = -50.00 dBm
Total Tx Power = -50.00 dBm
Rx Signal Power = -50.00 dBm
Tx Signal Power = -50.00 dBm
BR Power = -90.00 dBm
Tx Voa Attenuation = 15.0 dB
Ingress Ampli Mode = Gain
Ingress Ampli Gain = 0.0 dB
Ingress Ampli Tilt = 0.0 dB
Ingress Ampli Gain Range = Normal
Ingress Ampli Safety Control mode = auto
Ingress Ampli OSRI = OFF
Ingress Ampli Force Apr = OFF
Egress Ampli Mode = Gain
Egress Ampli Gain = 0.0 dB
Egress Ampli Tilt = 0.0 dB
Egress Ampli Safety Control mode = auto
Egress Ampli OSRI = OFF
Egress Ampli Force APR = OFF
Egress Ampli BR = ENABLE
```

Configured Parameters:

```
-----
Tx Voa Attenuation = 15.0 dB
Ingress Ampli Mode = Gain
Ingress Ampli Gain = 12.0 dB
Ingress Ampli Power = -1.0 dBm
Ingress Ampli Tilt = 0.0 dB
Ingress Ampli Gain Range = Normal
Ingress Ampli Safety Control mode = auto
Ingress Ampli OSRI = OFF
Ingress Ampli Force Apr = OFF
Egress Ampli Mode = Gain
Egress Ampli Gain = 16.0 dB
Egress Ampli Power = 5.0 dBm
Egress Ampli Tilt = 0.0 dB
Egress Ampli Safety Control mode = auto
Egress Ampli OSRI = OFF
Egress Ampli Force APR = OFF
Egress Ampli BR = ENABLE
BR High Threshold = -17.0 dBm
Rx Low Threshold = -3276.8 dBm
Tx Low Threshold = -3276.8 dBm
```

Solution

See [RX-LOC Alarm](#) to resolve this problem.

Troubleshooting Express Connection Failure Between Two Passive Devices

Problem

This problem occurs when there is a signal payload loss in the express connections between two passive devices due to a fiber cut. As a result, the LOS-P alarm is raised at the passive device controller OCH.

Topology and Component

To build this topology, you need the following hardware.

- Cisco NCS 1010 devices
- NCS1K-MD32E-C modules
- NCS1K-MD32O-C modules
- NCS1K-BRK-8 modules
- NCS1K-BRK-24 modules
- Cisco 8201 routers
- QDD-400G-ZR-S transceivers
- CFP2-400G-DCO transceivers
- Cisco NCS 1004 devices
- NCS1K4-2-QDD-C-K9 line card
- LC/LC cables
- MPO cables

The following figure displays the fiber cut between two passive devices:

Figure 7: Fiber Cut Between Two Passive Devices

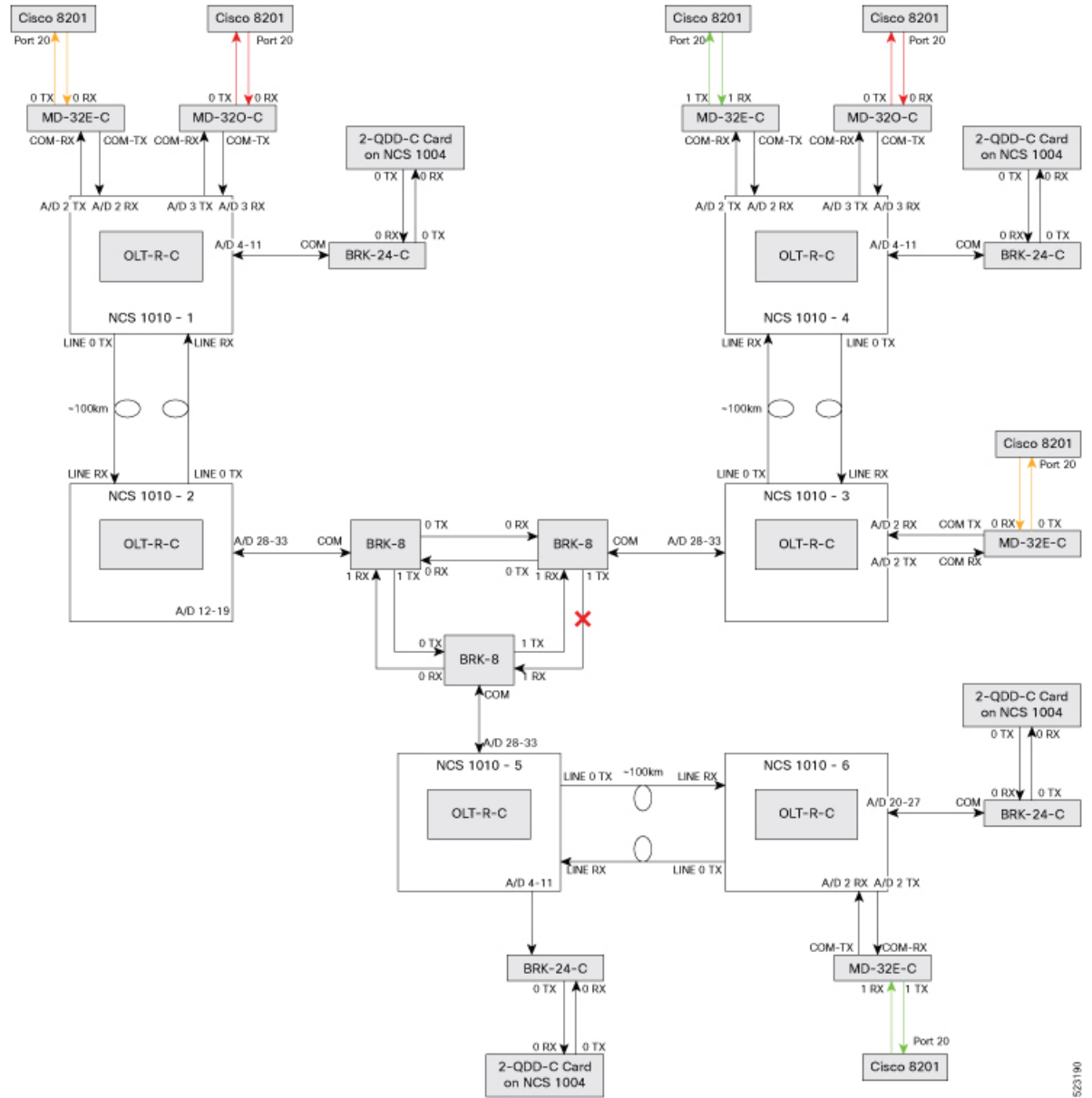

Example 1

The following example shows how to determine the fiber cut between two passive devices:

```
RP/0/RP0/CPU0:OLT-C-SITE-2#sh controllers och 0/3/0/0
Wed Apr 12 10:25:27.139 IST
```

Controller State: Down

Transport Admin State: In Service

LED State: Red

```

Alarm Status:
-----
Detected Alarms:
    RX-LOS-P

Alarm Statistics:
-----
RX-LOS-P = 1
TX-POWER-FAIL-LOW = 0

Parameter Statistics:
-----
Tx Power = 13.09 dBm
Rx Power = -50.00 dBm

```



Note The slot number 3 in the preceding show controller command is the USB cable port number to which BRK8 is connected (This USB number is derived from the show platform output).

Solution

See [RX-LOS-P](#) to resolve this alarm.

Troubleshooting Power Oscillation in the Network

Problem

This problem occurs when there is a power oscillation in the network.

Example 1

The following example shows the power fluctuation in the network:

```

RP/0/RP0/CPU0:ios#show controllers ots0/0/0/0 pm current 30-sec optics 1
Tue Mar 28 16:02:22.332 UTC

```

```

Optics in the current interval [16:02:00 - 16:02:22 Tue Mar 28 2023]

```

```

Optics current bucket type : Valid

```

	Configured	MIN	AVG	MAX	Operational	Configured	TCA	Operational
	Threshold(max)	Threshold(max)			Threshold(min)	Threshold(min)	(min)	Threshold(max)
OPT [dBm]	NA	-50.00	-7.32	6.10	-20.00	NA	NO	40.00
OPR [dBm]	NA	-50.00	-50.00	-50.00	-30.00	NA	NO	18.00
OPT (C+L) [dBm]	NA	19.50	19.51	19.70	-20.00	NA	NO	60.85
OPR (C+L) [dBm]	NA	10.60	10.64	10.70	-30.00	NA	NO	36.00
OPT (S) [dBm]	NA	-50.00	-50.00	-50.00	-5.00	NA	NO	28.00
OPR (S) [dBm]	NA	-50.00	-50.00	-50.00	-30.00	NA	NO	18.00

	NA		NO					
OPBR [dBm]	:	-50.00	-50.00	-50.00	-30.00	NA	NO	-14.09
	NA		NO					
EAGN [dB]	:	0.00	0.00	0.00	16.00	NA	NO	31.00
	NA		NO					
EATL [dB]	:	0.00	0.00	0.00	-5.00	NA	NO	5.00
	NA		NO					
IAGN [dB]	:	0.00	0.00	0.00	12.00	NA	NO	25.00
	NA		NO					
IATL [dB]	:	0.00	0.00	0.00	-5.00	NA	NO	5.00
	NA		NO					

Last clearing of "show controllers OPTICS" counters never

Solution

You need to monitor the performance monitor statistics of the corresponding OTS and OTS-OCH controllers to determine where the power oscillation occurs in the network. Check for the transient alarms on the node, such as RX-LOC and RX-LOS-P. See [RX-LOS-P](#) and [RX-LOC Alarm](#) to resolve this problem.

Troubleshooting Connection Verification Failures

sysdb_item_set_failed

The *sysdb_item_set_failed* error message is a warning condition that the system reports when incorrect configurations are made during connection verification. This message appears for the following conditions:

1. [Tone Generation Already In Progress](#)
2. [Tone Generation Has Invalid Pattern](#)
3. [Tone Generation Has Invalid Frequency](#)
4. [Tone Generation Start Failed](#)
5. [Tone Detection Has Invalid Pattern-Expected](#)

Error Message 1:

sysdb_item_set_failed('optics' detected the 'warning' condition 'Tone Generation Already In Progress')

Tone Generation Already In Progress appears when an attempt was made to start tone generation on one controller without stopping the tone generation operation on another controller.

The following example shows that the tone generation is initiated on port 5 OTS controller (*ots0/0/0/5*) while tone generation on port 4 OTS controller (*ots0/0/0/4*) is still in progress.

Example

```
RP/0/RP0/CPU0:ios#tone-pattern controller ots 0/0/0/4 start
Fri Sep 15 14:26:18.670 UTC
Tone pattern started
RP/0/RP0/CPU0:ios#tone-pattern controller ots 0/0/0/5 start
Fri Sep 15 14:27:20.418 UTC
sysdb_item_set_failed('optics' detected the 'warning' condition 'Tone Generation Already In Progress')
```

Solution

If you want to continue tone generation in the new OTS controller, then follow the following procedure to stop the tone generation that is already in progress.

1. Find the OTS controller that currently has tone generation in progress. To find, run the `show alarms brief system active` or `show alarms brief system conditions` command.

The following example shows that tone generation is active on the port 4 OTS controller.

Example

```
RP/0/RP0/CPU0:ios#show alarms brief system active
Thu Nov 23 06:42:20.077 UTC
```

Active Alarms

Location	Severity	Group	Set Time	Description
0/PM1	Major	Environ	11/17/2023 04:11:37 UTC	Power Module Error (PM_VIN_VOLT_OOR)
0/PM1	Major	Environ	11/17/2023 04:11:37 UTC	Power Module Output Disabled (PM_OUTPUT_DISABLED)
0	Major	Environ	11/17/2023 04:11:37 UTC	Power Group redundancy lost
0/RP0/CPU0	Minor	Software	11/17/2023 04:12:39 UTC	SW Upgrade is still allowed as SIA Grace Period is remaining
0/0	Minor	Controller	11/23/2023 02:34:38 UTC	Ots0/0/0/4 - Tone Generation In Progress
0/0	Critical	Controller	11/23/2023 06:41:07 UTC	Ots0/0/0/14 - Loss of Signal - Payload

2. Stop the tone generation in that OTS controller. To stop, run the `tone-pattern controller ots 0/0/0/4 stop` command.

The following example shows that tone pattern generation is stopped on the port 4 OTS controller.

Example

```
RP/0/RP0/CPU0:ios#tone-pattern controller ots 0/0/0/4 stop
Tue May 10 11:50:45.837 UTC
Tone pattern stopped
```

Error Message 2:

sysdb_item_set_failed('optics' detected the 'warning' condition 'Tone Generation Has Invalid Pattern')

The *Tone Generation Has Invalid Pattern* error message appears when an attempt was made to start the tone generation on the OTS controller without configuring the `tone-pattern` value for the controller.

The following example does not display `tone-pattern` for the `show run controller ots 0/0/0/4` command. Due to the absence of `tone-pattern`, the system reports the *Tone Generation Has Invalid Pattern* message.

Example

```
RP/0/RP0/CPU0:ios#show run controller ots 0/0/0/33
Fri Nov 3 10:17:01.999 UTC
controller Ots0/0/0/33
  tone-rate 25
  tone-frequency 196
!
```

```
RP/0/RP0/CPU0:Enceladus_1#tone-pattern controller ots 0/0/0/33 start
Fri Nov 3 10:17:46.389 UTC
sysdb_item_set_failed('optics' detected the 'warning' condition 'Tone Generation Has Invalid
Pattern')
RP/0/RP0/CPU0:ios
```

Solution

Set the `tone-pattern` value for the OTS controller. To set, run the following command:

Command Example

```
RP/0/RP0/CPU0:(config-Ots)#tone-pattern abcd1234
RP/0/RP0/CPU0:(config-Ots)#commit
```

Error Message 3:

```
sysdb_item_set_failed('optics' detected the 'warning' condition 'Tone Generation Has Invalid Frequency')
```

The *Tone Generation Has Invalid Frequency* error message appears when an attempt was made to start tone generation without configuring the `tone-frequency` value in the OTS controller.

The following example does not display `tone-frequency` for the `show run controller ots 0/0/0/4` command. Due to the absence of `tone-frequency`, the system reports the *Tone Generation Has Invalid Frequency* message.

Example

```
RP/0/RP0/CPU0:ios#show run controller ots 0/0/0/4
Fri Sep 15 14:37:03.381 UTC
controller Ots0/0/0/4
  tone-rate 2
  tone-pattern abcd1234
  tone-detect-oob
  tone-pattern-expected abcd1234
!

RP/0/RP0/CPU0:ios#tone-pattern controller ots 0/0/0/4 start
Fri Sep 15 14:37:41.777 UTC
sysdb_item_set_failed('optics' detected the 'warning' condition 'Tone Generation Has Invalid
Frequency')
RP/0/RP0/CPU0:ios#
```

Solution

Set the `tone-frequency` value in out-of-band (OOB) frequency for the OTS controller. To set, run the following command:

Command Example

```
RP/0/RP0/CPU0:(config-Ots)#tone-frequency 191.175
RP/0/RP0/CPU0:(config-Ots)#commit
```

Error Message 4:

```
sysdb_item_set_failed('optics' detected the 'warning' condition 'Tone Generation Start Failed')
```

The *Tone Generation Start Failed* error message appears when an attempt was made to start tone generation using an in-band frequency of a provisioned channel.

The following example shows that `tone-frequency` is configured for the `show run controller ots 0/0/0/33` command. However, the `tone-frequency` value that is configured is the central frequency (191.375) of the provisioned channel 1. Hence, the system reports the *Tone Generation Start Failed* message.

Example

```
RP/0/RP0/CPU0:ios#show hw-module location 0/0/NXR0 terminal-ampli
Fri Nov 3 10:31:25.329 UTC
```

Legend:

```
NXC      - Channel not cross-connected
ACTIVE - Channel cross-connected to data port
ASE      - Channel filled with ASE
FAILED - Data channel failed, pending transition to ASE
```

```
Location:          0/0/NXR0
```

```
Status:           Provisioned
```

Flex Grid Info

Channel Number	Centre Frequency (THz)	Channel Width (GHz)	Channel Status
Overlapping Channels			
1	191.375000	75.000	ACTIVE
- , 2			
2	191.435000	75.000	ASE
1 , -			

```
RP/0/RP0/CPU0:ios#show run controller ots 0/0/0/33
```

```
Fri Nov 3 10:38:44.414 UTC
```

```
controller Ots0/0/0/33
```

```
tone-rate 25
```

```
tone-pattern abcd1234
```

```
tone-frequency 191.375
```

```
!
```

```
RP/0/RP0/CPU0:ios#tone-pattern controller ots 0/0/0/33 start
```

```
Fri Nov 3 10:39:03.532 UTC
```

```
sysdb_item_set_failed('optics' detected the 'warning' condition 'Tone Generation Start Failed')
```

```
RP/0/RP0/CPU0:ios#
```

Solution

Set the `tone-frequency` value in the out-of-band (OOB) frequency for the OTS controller. To set, run the following command:

Command Example

```
RP/0/RP0/CPU0:(config-Ots)#tone-frequency 191.175
```

```
RP/0/RP0/CPU0:(config-Ots)#commit
```

Error Message 5:

sysdb_item_set_failed('optics' detected the 'warning' condition 'Tone Detection Has Invalid Pattern-Expected')

The *Tone Detection Has Invalid Pattern-Expected* error message appears when an attempt was made to start tone generation without configuring the expected tone pattern in the OTS, OMS, or OCH controller.

The following example shows the `show run controller ots 0/0/0/33` output without the `tone-pattern-expected` value. Due to the absence of `tone-pattern-expected`, the system reports the *Tone Detection Has Invalid Pattern-Expected* message.

Example

```
RP/0/RP0/CPU0:ios#show run controller ots 0/0/0/33
Fri Nov 3 10:45:29.171 UTC
controller Ots0/0/0/33
  tone-rate 25
  tone-pattern abcd1234
  tone-frequency 191.375
!

RP/0/RP0/CPU0:ios#tone-pattern-detect controller ots 0/0/0/33 start
Fri Nov 3 10:46:01.585 UTC
sysdb_item_set_failed('optics' detected the 'warning' condition 'Tone Detection Has Invalid
  Pattern-Expected')
RP/0/RP0/CPU0:ios#
```

Solution

Set the `tone-pattern-expected` value on the controller that is expecting the tone pattern. In this example, the tone pattern is expected on the OTS controller. To set, run the following command:

Command Example

```
RP/0/RP0/CPU0:(config-Ots)#tone-pattern-expected abcd1234
RP/0/RP0/CPU0:(config-Ots)#commit
```

Failed to Commit One or More Configuration Items During a Pseudo-Atomic Operation.

The NCS 1010 CLI fails to commit connection verification configuration when an attempt was made to set an incorrect value or parameter on an OTS controller.

In the following examples, the *Failed to commit one or more configuration...* error message appears to indicate that controller configuration has failed.

Example 1:

Example

```
RP/0/RP0/CPU0:ios#configure
Fri Sep 15 14:38:18.254 UTC
RP/0/RP0/CPU0:ios(config)#controller ots 0/0/0/4
RP/0/RP0/CPU0:ios(config-Ots)#tone-frequency 30
RP/0/RP0/CPU0:ios(config-Ots)#commit
Fri Sep 15 14:38:50.918 UTC
```

```
% Failed to commit one or more configuration items during a pseudo-atomic operation. All
changes made have been reverted. Please issue 'show configuration failed [inheritance]'
from this session to view the errors
```

Solution 1:

Run the `show configuration failed` command to find the cause for the system to fail the OTS controller configuration.

Command

```
RP/0/RP0/CPU0:ios(config-Ots)#show configuration failed
Fri Sep 15 14:38:57.773 UTC
!! SEMANTIC ERRORS: This configuration was rejected by
!! the system due to semantic errors. The individual
!! errors with each failed configuration command can be
!! found below.
```

```

controller Ots0/0/0/4
  tone-frequency 30
  !!! Invalid argument: Entered value not supported. Range supported by the platform is from
  191.175000 to 196.100000
  !
end

```

The preceding output shows that an unsupported value is entered for `tone-frequency`. The output also suggests the frequency range (`191.175000...196.100000`) that the platform supports for connection verification.

Example 2:

Example

```

RP/0/RP0/CPU0:ios#configure
Fri Sep 15 14:45:44.275 UTC
RP/0/RP0/CPU0:ios(config)#controller ots 0/0/0/4
RP/0/RP0/CPU0:ios(config-Ots)#tone-pattern ?
  LINE Enter Hex Values(Max Length 64 Bytes)
RP/0/RP0/CPU0:ios(config-Ots)#tone-pattern xxxyyyyzzz
RP/0/RP0/CPU0:ios(config-Ots)#commit
Fri Sep 15 14:46:20.073 UTC

```

```

% Failed to commit one or more configuration items during a pseudo-atomic operation. All
changes made have been reverted. Please issue 'show configuration failed [inheritance]'
from this session to view the errors

```

Solution 2:

Command

```

RP/0/RP0/CPU0:iosconfig-Ots)#show configuration failed
Fri Sep 15 14:46:39.396 UTC
!! SEMANTIC ERRORS: This configuration was rejected by
!! the system due to semantic errors. The individual
!! errors with each failed configuration command can be
!! found below.

```

```

controller Ots0/0/0/4
  tone-pattern xxxyyyyzzz
  !!! Invalid argument: invalid hex value,valid value is 0-9 a-f A-F
  !
end

```

The preceding output shows that an unsupported value is entered for `tone-pattern`. The output also suggests the supported values for tone pattern.

Example 3:

Example

```

RP/0/RP0/CPU0:ios#configure
Fri Sep 15 15:14:36.131 UTC
RP/0/RP0/CPU0:ios(config)#controller och 0/3/0/1
RP/0/RP0/CPU0:ios(config-Och)#tone-detect-oob
RP/0/RP0/CPU0:ios(config-Och)#commit
Fri Sep 15 15:14:57.286 UTC

```

```

% Failed to commit one or more configuration items during a pseudo-atomic operation. All
changes made have been reverted. Please issue 'show configuration failed [inheritance]'
from this session to view the errors

```

Solution 3:

Command

```
RP/0/RP0/CPU0:ios(config-Och)#show configuration failed
Fri Sep 15 15:15:06.219 UTC
!! SEMANTIC ERRORS: This configuration was rejected by
!! the system due to semantic errors. The individual
!! errors with each failed configuration command can be
!! found below.

controller Och0/3/0/1
  tone-detect-oob
  !% Invalid argument: Tone Detect OOB is not configurable for this controller
  !
end
```

The preceding output informs that Tone Detect OOB is not configurable on OCH controllers. Configure OOB only on OMS controllers.

Invalid Input Detected at '^' Marker

The *Invalid input detected at '^' marker* error message appears when an attempt was made to start tone generation on the OMS and OCH controllers. Tone generation must be initiated on the OTS controller. The OMS and OCH controllers should be used only to detect the tone that is generated from the OTS controller.

The following example shows the system reporting the *Invalid input detected at '^' marker* error message on the port 0 OMS controller (*oms 0/3/0/0*).

Example

```
RP/0/RP0/CPU0:ios#tone-pattern controller oms 0/3/0/0 start
                                     ^
% Invalid input detected at '^' marker.
RP/0/RP0/CPU0:ios#
```

The following example shows the system reporting the *Invalid input detected at '^' marker* error message on the port 1 OCH controller (*och 0/3/0/1*).

Example

```
RP/0/RP0/CPU0:ios#tone-pattern controller och 0/3/0/1 start
                                     ^
% Invalid input detected at '^' marker.
```

Solution

Use the OMS and OCH controllers for detecting the tone generation only. See for OCH and OMS controller syntax and parameters.

