



Prepare to Install Cisco NCS 1004

This chapter explains how to prepare for the Cisco NCS 1004 installation.

- [Shipping and Receiving, on page 1](#)
- [Unpack and Verify Cisco NCS 1004, on page 7](#)

Shipping and Receiving

The chassis is shipped in one of the following ways:

- Chassis with filler cards and line cards— you receive the chassis with preinstalled line cards (based on the number of line cards you have ordered) and the rest of the line card slots have filler cards. If you have preordered four line cards, then, the chassis does not contain any filler cards. There are four fiber management brackets in the package, for each of the line card or filler cards preinstalled in the chassis. The controller and the three fan units are also preinstalled. The other items available in the same package (with the chassis) are:
 - Accessory kit, that has all the installation hardware.
 - Spare Serial Number label.
 - Two PSUs - AC or DC. Installation of PSUs is discussed in the [Installation of Modules](#) chapter.

AC chassis - while ordering for an AC chassis, select the power cable. Based on your choice (NEMA or CEE), you get a pair of 90 degree and straight cables for each PSU. All the AC cables are 4.25 m long.

Table 1: Power cables for the chassis

Type of Cable	P1 Connector	P2 Connector	CPN
Straight cable	NEMA L6-20P	IEC 60320 – C21	72-101432-01
	CEE 7/7 (Europe)	IEC 60320 – C21	72-101434-01
90-degree cable	CEE 7/7 (Europe)	IEC 60320 – C21	72-101425-01
	NEMA L6-20P	IEC 60320 – C21	37-1138-01

Figure 1: 90-degree Cable (CEE 7/7)

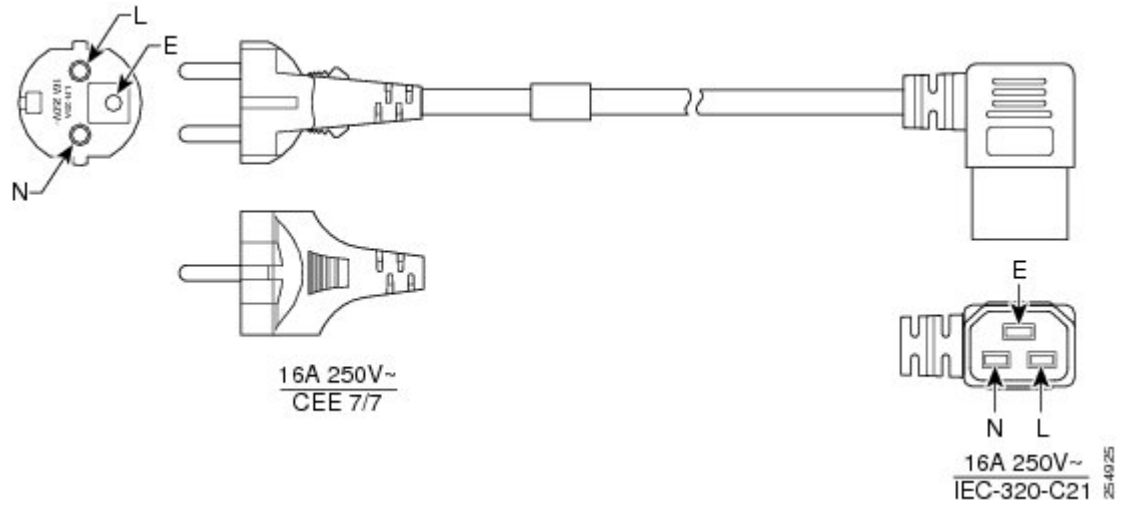

Figure 2: 90-degree Cable (NEMA L6-20P)

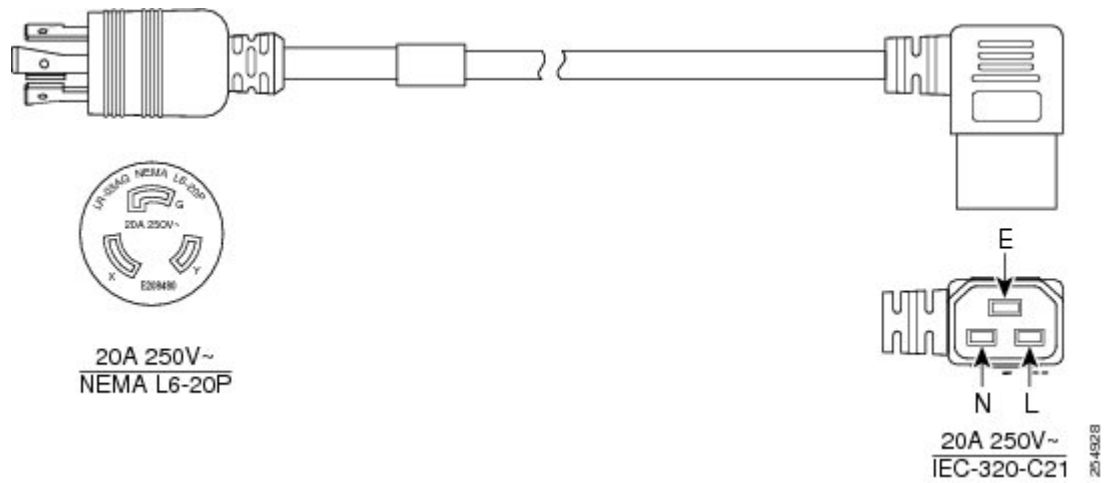

Figure 3: Straight Cable (NEMA L6-20P)

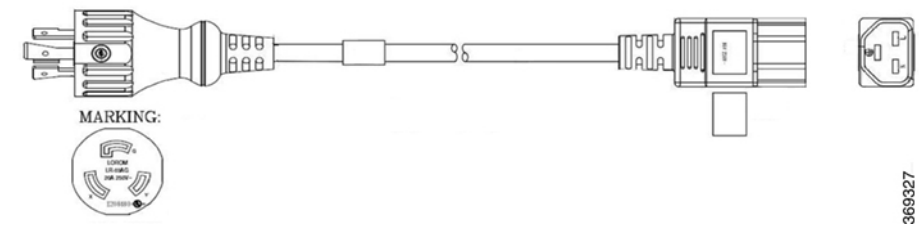
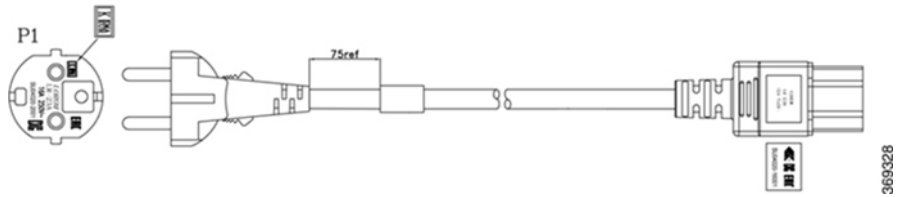

Figure 4: Straight Cable (CEE 7/7)



Note The 90deg cable is used only for ETSI racks to maintain a footprint of 600 mm.

DC chassis - when you order for a DC chassis, you get four power lugs for each PSU (a pair of 90-degree and a pair of 180-degree lugs). 180-degree lugs are used for ETSI racks to maintain a footprint of 600 mm.

Figure 5: DC Power Cable Lug (180-degree)

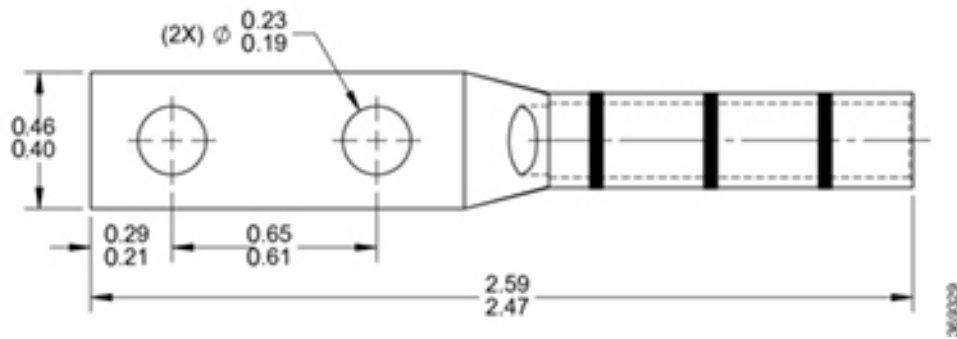
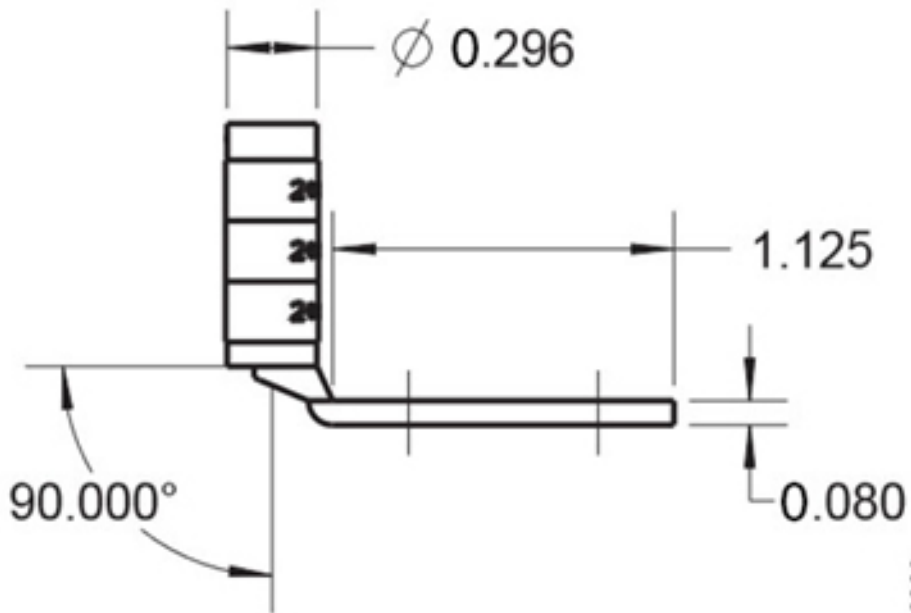
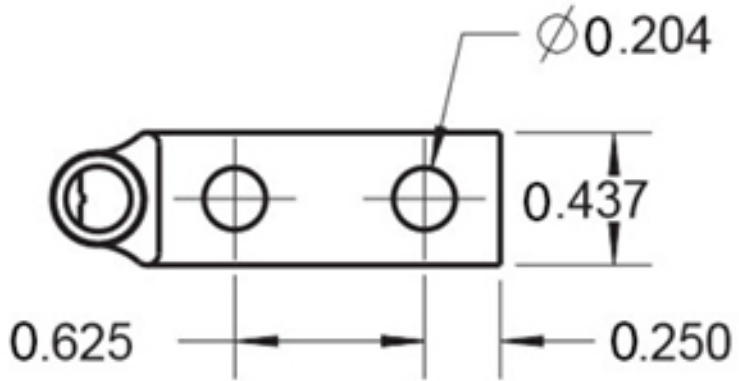
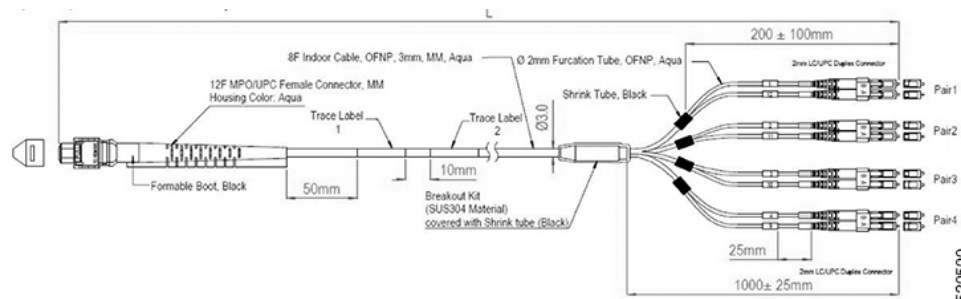

Figure 6: DC Power Cable Lug (90-degree)



369330

Figure 7: Breakout Cable



520500



Note The breakout cable is used only for ETSI racks to maintain a footprint of 600 mm.

Table 2: Specifications of Breakout Cables

PID	CPN	MPN	Overall Length (in m)
ONS-4X10-MMCBL-5=	72-101758-01	BCJ7F3FM005CSO008	05 plus or minus 0.30
ONS-4X10-MMCBL-10=	72-101759-01	BCJ7F3FM010CSO008	10 plus or minus 0.30
ONS-4X10-MMCBL-20=	72-101760-01	BCJ7F3FM020CSO008	20 plus or minus 0.60

Figure 8: Cable with Formable Boot and Standard Boot



The formable boot must be used on the side of the line card.

Table 3: PIDs of Cable with Formable Boot and Standard Boot

PID#	CPN#	MPN#	Overall Length (M)
-ONS-FMPO-SM-5=	72-101717-01	MDD3F 3GM005CSO001	05±0.30 m
-ONS-FMPO-SM-10=	72-101718-01	MDD3F 3GM010CSO001	10±0.30 m
-ONS-FMPO-SM-20=	72-101719-01	MDD3F 3GM020CSO001	20±0.60 m
-ONS-FMPO-SM-30=	72-101720-01	MDD3F 3GM030CSO001	30±0.90 m
-ONS-FMPO-SM-40=	72-101721-01	MDD3F 3GM040CSO001	40±1.20 m
-ONS-FMPO-SM-50=	72-101722-01	MDD3F 3GM050CSO001	50±1.50 m
-ONS-FMPO-SM-60=	72-101723-01	MDD3F 3GM060CSO001	60±1.50 m

520624

PID#	CPN#	MPN#	Overall Length (M)
-ONS-FMPO-SM-70=	72-101724-01	MDD3F 3GM070CSO001	70±1.50 m
-ONS-FMPO-SM-80=	72-101725-01	MDD3F 3GM080CSO001	80±1.50 m
-ONS-FMPO-SM-90=	72-101726-01	MDD3F 3GM090CSO001	90±1.50 m
-ONS-FMPO-SM-100=	72-101727-01	MDD3F 3GM100CSO001	100±1.50 m

Figure 9: Chassis shipped with Line Cards

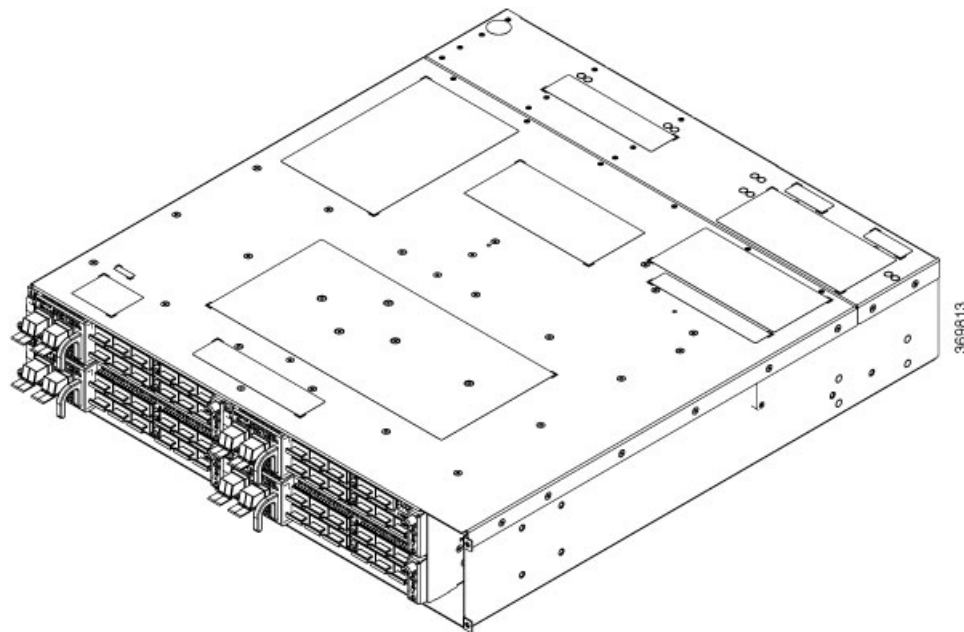

- Chassis with only filler cards— you receive the chassis with four filler cards in the line card slots. There are four fiber management brackets in the package, for each of the filler cards. Each line card ordered as a spare item is shipped separately and the extra fiber management bracket (for the line card) is available in the line card package. Only the accessory kit is available with the chassis (in the same package). You must order all the other modules (fan units, controller, PSUs) separately.

For installation procedures of the modules, see [Installation of Modules](#) chapter.

Figure 10: Chassis shipped with Filler Cards

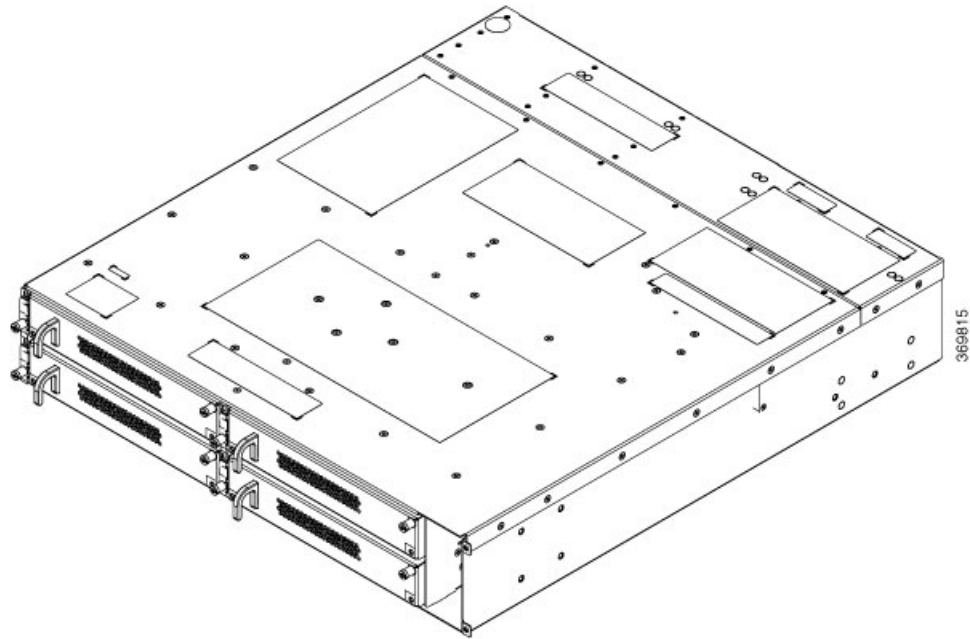

Unpack and Verify Cisco NCS 1004

This procedure enables the you to unpack and check if all the chassis modules that are required for installation have been shipped.

-
- Step 1** When you receive Cisco NCS 1004 equipment at the installation site, open the top of the box.
- Step 2** Remove accessories and foam inserts from the box. The box contains Cisco NCS 1004 and other items needed for installation.
- Step 3** To remove the chassis from the packaging, grasp the side of the chassis and lift it out of the box. Use these lifting guidelines to avoid injury to yourself or damage to the equipment:
- Do not lift equipment alone; have another person help you to lift the equipment.

Figure 11: Lifting the NCS 1004

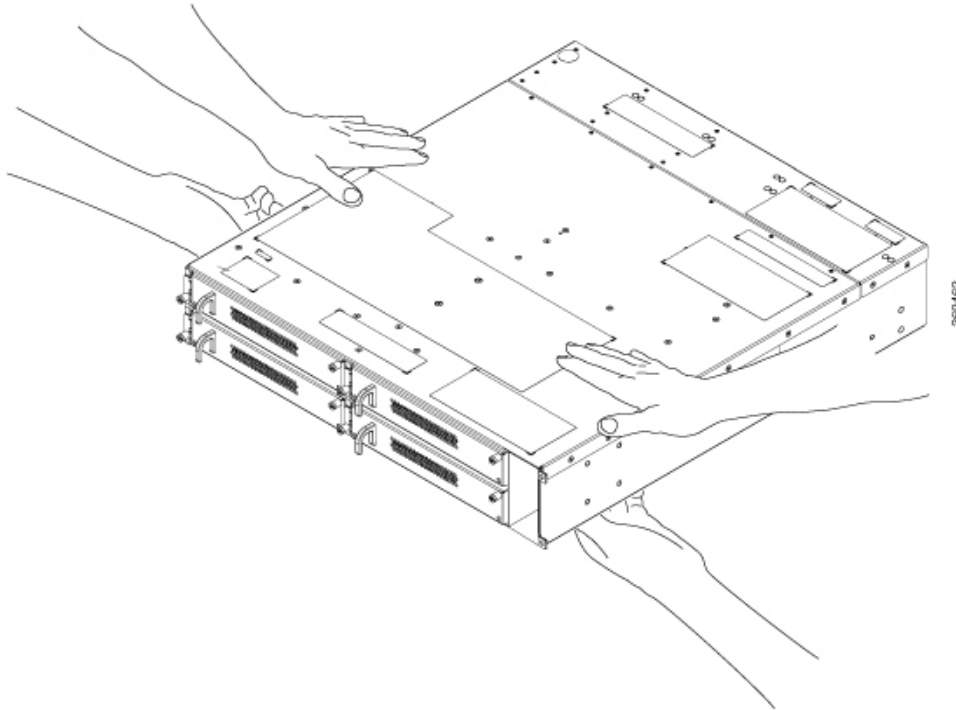

A fully loaded chassis can weigh as much as 28.7 kgs (63.3 lbs).

- Ensure that your footing is solid; balance the weight of the object between your feet.
- Lift the equipment slowly; never move suddenly or twist your body as you lift.
- Keep your back straight and lift with your legs, not your back. When bending down to lift equipment, bend at the knees (not at the waist), to reduce the strain on your lower back muscles.

Step 4 Verify the following:

- The Cisco NCS 1004 is not damaged. Check for a scratch, bend, discoloration or deformation on the Cisco NCS 1004 chassis.
- The modules that are shipped with the chassis or separately are not damaged.

Step 5 If there is any damage to the chassis or the modules, call your Cisco sales engineer for a replacement.
