



Install Cisco NCS 1004 Modules

This chapter contains procedures to install the modules of Cisco NCS 1004.



Caution

All the modular slots in the NCS 1004 chassis should always be populated with respective modules (line-cards, controller, PSU & fan units). Empty line card slots to be populated with filler modules, which are shipped with the chassis. The replacement or upgrade of the modules (Online Insertion or Removal, OIR) to be performed only when the ambient temperature is below 30-degree C. The OIR of modules should be completed within five minutes to prevent overheating of the components.



WARNING: DO NOT INTRODUCE BODY OR OBJECT IN THE CHASSIS / PSU / FAN TRAY / LC SLOTS WHEN INSTALLING OR REMOVING A MODULE. EXPOSED CIRCUITRY IS AN ENERGY HAZARD.



ATTENTION: ÉVITEZ TOUT CONTACT ENTRE VOTRE CORPS OU UN OBJET EXTERNE ET L'INTÉRIEUR DU CHÂSSIS, DU BLOC D'ALIMENTATION, LA FENTE DE VENTILATION DU PLATEAU, OU DE LA FENTE PDS LORSQUE VOUS INSTALLEZ OU RETIREZ UN MODULE. LES CIRCUITS EXPOSÉS CONSTITUENT UN RISQUE D'ÉLECTROCUTION.

- [Supported Controller Cards, on page 2](#)
- [About Line Cards, on page 3](#)
- [Install Power Supply, on page 9](#)
- [Install Fan Unit, on page 14](#)
- [Attach Fiber Management Bracket, on page 15](#)
- [Adjust Fiber Management Bracket of the 1.2T, 1.2TL, 2-QDD-C, and QXP-K9 Line Cards, on page 16](#)
- [Adjust Fiber Management Bracket of the OTN-XP Line Card, on page 17](#)
- [Install Pluggables, on page 18](#)
- [Air Filter, on page 23](#)

Supported Controller Cards

Table 1: Feature History

Feature Name	Release Information	Description
NCS1K4-CNTRLR-B-K9 Controller Card	Cisco IOS XR Release 7.5.1	NCS 1004 supports the NCS1K4-CNTRLR-B-K9 controller card. The card supports a default of 9600 baud rate on the RS232 console port and runs on BIOS version 5.10.

The Cisco NCS 1004 supports the following controller cards:

- **NCS1K4-CNTRLR-K9**

The NCS1K4-CNTRLR-K9 controller card supports a default of 115200 baud rate on the RS232 console port and runs on BIOS version 4.20. The controller card has two USB 3.0, two 10/100/1000 Ethernet, one RS232 console and one SFP ports. The SFP port of the controller card supports 1GE payload.

- **NCS1K4-CNTRLR-B-K9**

The NCS1K4-CNTRLR-B-K9 controller card supports a default of 9600 baud rate on the RS232 console port and runs on BIOS version 5.10. The controller card has two USB 3.0, two 10/100/1000 Ethernet, one RS232 console and one SFP ports. The SFP port of the controller card supports 1GE payload.

Install Controller

This task has information about installing the controller into the chassis.

Step 1 Orient the controller correctly before inserting. Check for the *This Side Up* label.

Step 2 Supporting the controller at the bottom with one of your hands, slide the controller into the slot, using the handle.

Figure 1: Installing the Controller Unit

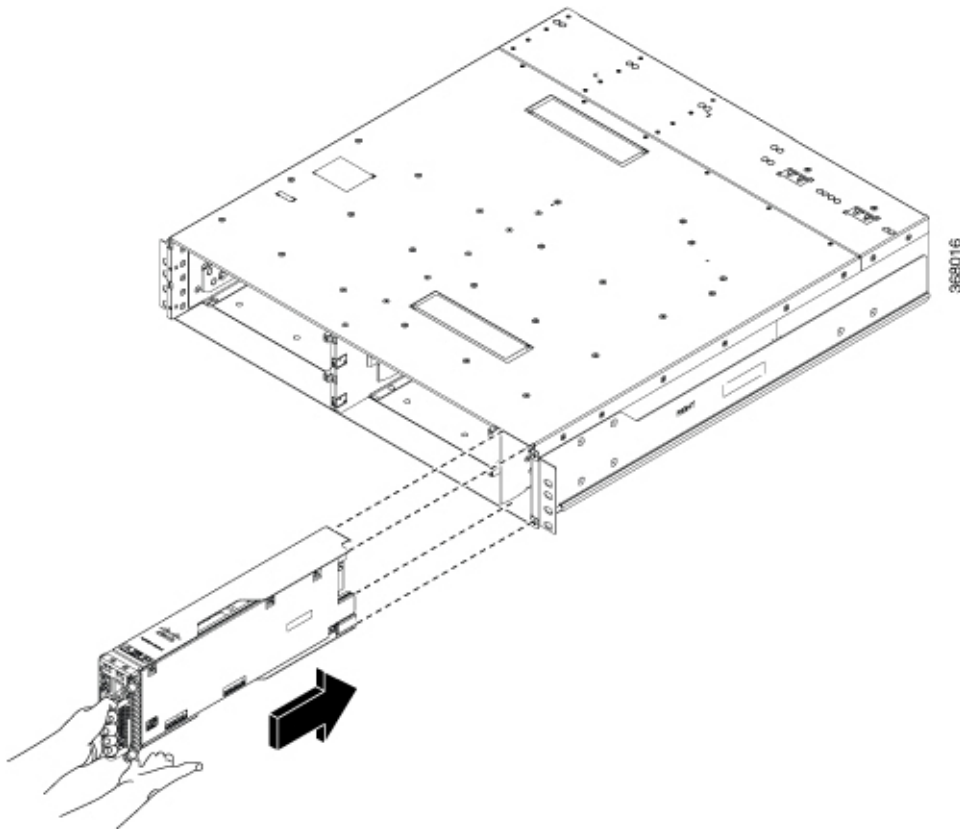

Step 3 Using a T15 Torx screwdriver, tighten the two M3 T15 torx screws to a torque value of 0.65 N-m.

About Line Cards

The Cisco NCS 1004 supports the following line cards:

- 1.2T DWDM Line Card
- 1.2TL DWDM Line Card
- 2-QDD-C DWDM Line Card
- OTN-XP DWDM Line Card
- NCS1K4-QXP-K9 Line Card

1.2T Line Card

1.2Tbps DWDM line card can provide up to 12 OTU4 or three 400G client ports. For more details of the 1.2T line card, see the [data sheet](#).

The physical characteristics of the 1.2T line card are:

- Height—40.4 mm
- Breadth—191.9 mm
- Depth—277 mm without the fiber management bracket; 297.97 mm with the fiber management bracket
- Weight—3.2 kg

For the LED details of the line card, see the [Line Card LEDs](#) section.

1.2TL Line Card

1.2TL DWDM line card can provide up to 8 QSFP-28 based client ports and 2 trunk ports. For more details of the 1.2TL line card, see the [data sheet](#).

The physical characteristics of the 1.2TL line card are same as that of the 1.2T line card. For the LED details of the line card, see the [Line Card LEDs](#) section.

2-QDD-C Line Card

Table 2: Feature History

Feature Name	Release Information	Description
NCS1K4-2-QDD-C-K9 C-Band Line Card	Cisco IOS XR Release 7.3.1	NCS 1004 supports the NCS1K4-2-QDD-C-K9 C-Band line card. The card has eight client ports (QSFP28 and QSFP-DD) and two DWDM dual sub-channel module trunk ports. Each trunk port is capable of 200, 300, and 400 Gbps line rate.

2-QDD-C DWDM line card can provide up to eight QSFP client ports, six of which can support QSFP-28 based client ports and remaining two can support QSFP-28, QSFP-DD, QSFP-ZR, and QSFP-ZR+ client ports. For more details of the 2-QDD-C line card, see the [data sheet](#).

The eight client ports are divided into two sets of four slots each. The following two configurations are supported:

- A maximum of eight QSFP-28, four for each set, configured either as 100GE or 100G OTL4.4.
- A maximum of two QSFP-DD/ZR/ZR+, configured as 400GE.

The physical characteristics of the 2-QDD-C line card are:

- Height—40.4 mm
- Breadth—191.9 mm
- Depth—277 mm without the fiber management bracket; 297.97 mm with the fiber management bracket
- Weight—3.2 kg

For the LED details of the line card, see the [Line Card LEDs](#) section.

OTN-XP Line Card

The OTN-XP line card supports up to 1.6Tbps of OTN aggregation switching functionality to optimize the available bandwidth. A single line card supports 8x100GE muxponder or 2x400 GE transponder applications.

The OTN-XP line card contains:

- Eight QSFP 28 ports
- Four QSFP-DD ports
- Two CFP2 ports

For LED details of the card, see [LEDs of OTN-XP Line Card](#).

The OTN-XP line card supports 400GE/OTUC4, 100GE/OTU4, 10GE/OTU2/OTU2e, 16G FC, 32G FC client rates.

The supported operating modes are:

- 2x Muxponder
- 2x Transponder
- Single-card 1.2T OTN XPonder
- Dual-card 1.6T OTN XPonder

The physical dimensions of the OTN-XP line card are:

- Height—40.4 mm
- Breadth—191.9 mm
- Depth—282 mm without fiber management bracket; 366.7 mm with fiber management bracket
- Weight—2.6 kg



Note When the data path device temperature of the OTN-XP card exceeds the critical threshold level of 108° Celsius, a sensor alarm is raised and the data path is shut down. This impacts traffic. However, the card is still operational.

For more details about the OTN-XP line card, see the [data sheet](#).

QXP-K9 Line Card

Table 3: Feature History

Feature Name	Release Information	Description
NCS1K4-QXP-K9 Line Card	Cisco IOS XR Release 7.7.1	<p>NCS1K4-QXP-K9 line card delivers low cost 100G and 400G DWDM transmission with ZR+ optics on a router. This line card can be used in both traditional Optical Networking solution and in Routed Optical Networking solution. This line card has 16 pluggable ports with eight QSFP-DD client ports and eight QSFP-DD trunk ports.</p> <p>For more information about the NCS1K4-QXP-K9 card, see the datasheet.</p> <p>NCS1K4-QXP-K9 card supports the following key features:</p> <ul style="list-style-type: none"> • Client rates: 400GE, 4x100GE, and 100GE Ethernet • Modulation formats: 16 QAM for 400GE Txp/4x100GE Mxp and QPSK for 100GE Txp • Smart licensing: The license calculation is based on the number of trunk slices provisioned. <p>For more information about the key features, see QXP Card and smart licensing.</p>

The QXP-K9 line card provides up to 16 QSFP-DD ports (eight QSFP-DD client ports and eight QSFP-DD trunk ports). The card supports 400G ETH, 4x100GE ETH, and 100G ETH without FEC client rates.

The supported operating modes are:

- 400G-TXP
- 4*100G MXP
- 100G TXP [without FEC]

The physical dimensions of the QXP-K9 line card are:

- Height—40.4 mm

- Breadth—191.9 mm
- Depth—277 mm without the fiber management bracket; 394.7 mm with the fiber management bracket
- Weight—2.5 kg

For LED details of the line card, see [LEDs of QXP-K9 Line Card](#). For more details of the QXP-K9 line card, see the [data sheet](#).

Install Line Card



Important Release 7.0.1 requires one of these options if the line card does not restart or crashes:

- Install the Mandatory Software Maintenance Upgrades

Cisco IOS XR Software Release	SMU File Names
7.0.1	ncs1004-7.0.1.CSCvr50760.tar
	ncs1004-sysadmin-7.0.1.CSCvr50760.tar

- Upgrade

Migrate the software to Cisco IOS XR Software Release 7.1.1 or later. These releases do not require any of the SMUs.

See the [NCS 1001 Software Download page](#) for the latest software releases.

This task has details about installing a line card in to the NCS 1004 chassis. The chassis is shipped with filler cards and/or line cards. The Cisco NCS 1004 chassis supports a maximum of four line cards.

Before you begin

It is mandatory to attach the fiber management brackets to the filler cards and line cards before installing the chassis onto a rack. For a detailed procedure, see the [Attach Fiber Management Bracket](#) section.



Note The following procedure is not required if the chassis is shipped with preinstalled line cards.

-
- Step 1** Unscrew the Torx screws of the filler card using a T15 Torx screwdriver.
- Step 2** Holding the fiber management bracket of the filler card with one hand and supporting it with the other, remove the filler card from the chassis.
- Step 3** Attach the fiber management bracket to the line card that needs to be installed. Follow the procedure as mentioned at the beginning of the section.
- Step 4** Orient the line card. Check for the *This Side Up* label.
- Step 5** Use both the hands while inserting a line card. Use one hand to hold the line card using the fiber management bracket and the other hand along the base of the card to guide it into the slot.

Figure 2: Installing the OTN-XP Line Card

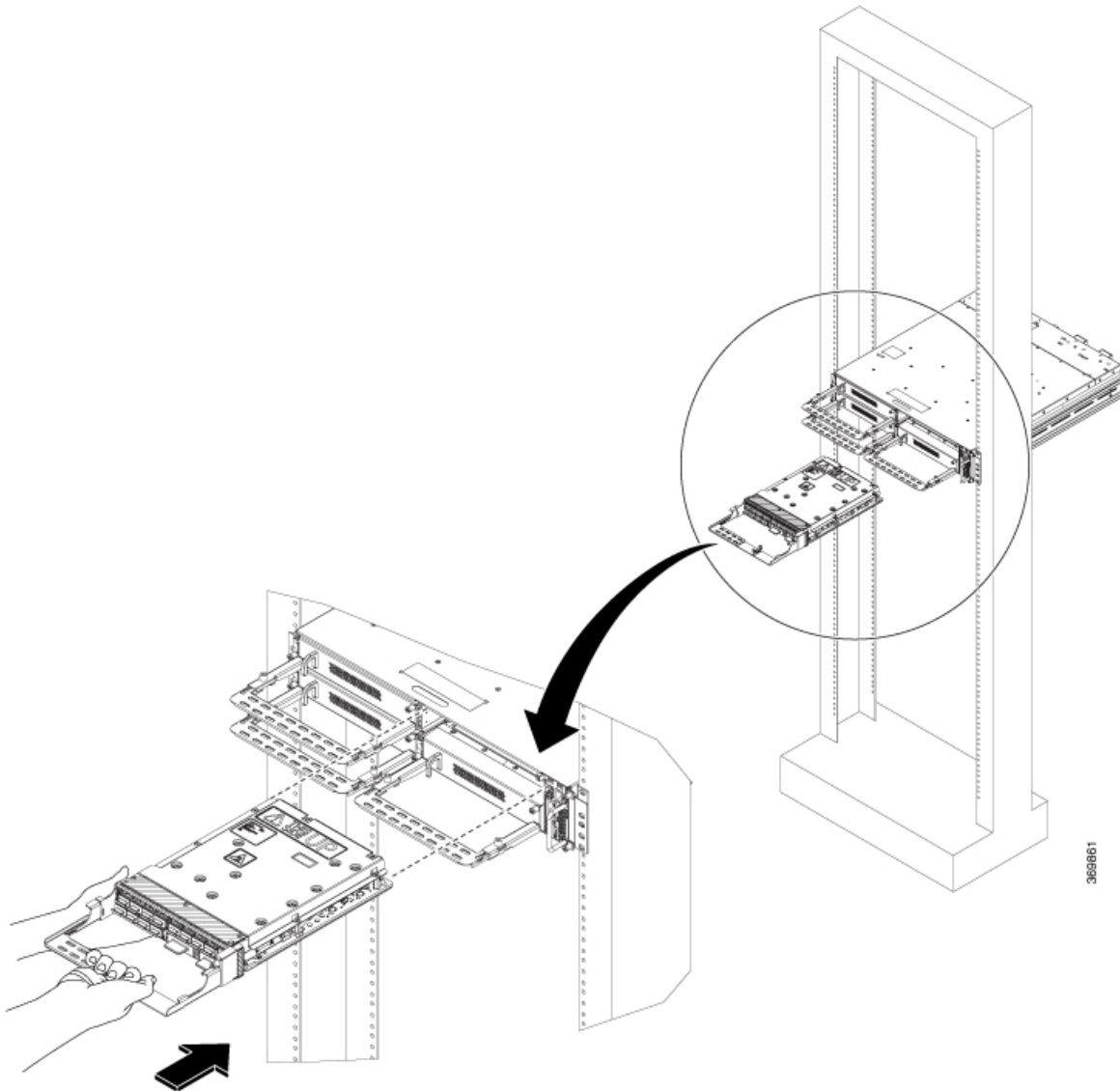
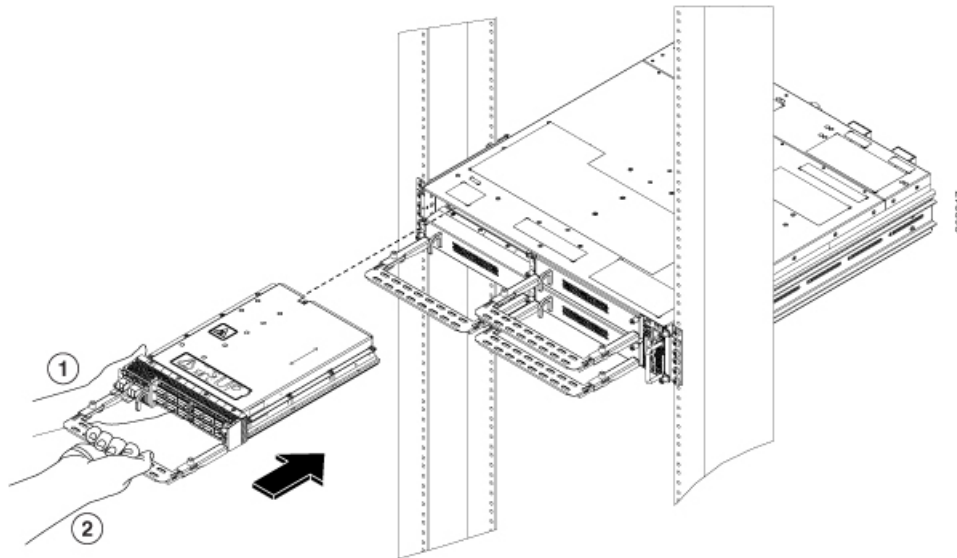

Figure 3: Installing the 1.2T, 1.2TL, 2-QDD-C, and QXP-K9 Line Cards



1	Support the line card with your hand at the bottom, while installing (or removing) a line card.
2	Use the fiber management bracket for holding the line card.

Caution Use the fiber management brackets only for pulling out while removing or pushing in the card while installing line cards or filler cards. Do not use the fiber management brackets to carry the cards. Always support the line card (or filler card) at the bottom with your hand.

Step 6 Slide the line card completely inside, into the card guide.

Step 7 Using the Torx screwdriver, tighten the two M3, T15 Torx screws of the line card, to a torque value of 0.65 N-m.

Install Power Supply

This task has information about installing the PSUs into the NCS 1004 chassis.

Step 1 Orient the PSU correctly before inserting. Check for the *This Side Up* label.

Step 2 Using the handle, slide the PSU into the slot (support the PSU at the bottom with your hand) and push it in until you hear a *click* sound; direction of insertion is shown in the following figure. The click sound indicates that the unit has been latched (the locking latch needs to be pressed and released only for removing the PSU).

Figure 4: Installing a PSU

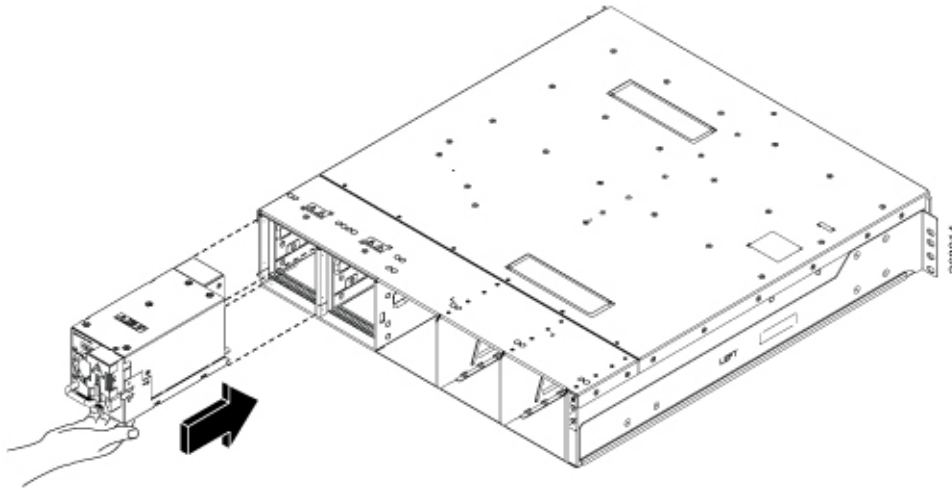

Connect DC Power to NCS 1004



Caution NCS 1004 relies on the protective devices in the building installation to protect against short circuit, overcurrent, and ground faults. Ensure that the protective devices comply with local and national electrical codes.

Figure 5: Rating Label for DC Power

RATINGS AND STATEMENTS FOR DC MAINS POWERED SYSTEM	
PRODUCT RATING (輸入): -48V/-60V; 44A MAX (2X)	PARAMÈTRES ÉLECTRIQUES (輸入): -48V/-60V; 44A MAX (2X)
FOR SUPPLY CONNECTIONS USE WIRES SUITABLE FOR AT LEAST 75°C	POUR DES RACCORDS D'ALIMENTATION, UTILISEZ DES CÂBLES COMPATIBLES À UNE TEMPÉRATURE POUR AU MOINS 75°C
USE ONLY WITH 6 AWG COPPER WIRE	UTILISER UNIQUEMENT AVEC UN CÂBLE DE CUIVRE DE CALIBRE 6 AWG
READ USER MANUAL	LIRE MANUEL D'UTILISATION
SHOCK HAZARD	RISQUE D'ÉLECTROCUTION
CAUTION - THIS UNIT HAS MORE THAN ONE POWER CONNECTION. TURN OFF POWER SOURCE CIRCUIT BREAKERS AND REMOVE ALL CONNECTIONS TO DE-ENERGIZE SYSTEM	AVERTISSEMENT - CETTE UNITÉ COMPORTE PLUSIEURS RACCORDS D'ALIMENTATION. DÉACTIVEZ L'INTERRUPTEUR D'ALIMENTATION ET DÉBRANCHEZ LE SYSTÈME DE TOUTES LES PRISES POUR LE METTRE HORS TENSION

355972

- Step 1** Verify that the correct fuse panel is installed in the top mounting space.
- Step 2** Measure and cut the cables as needed to reach NCS 1004 from the fuse panel.

- Step 3** Dress the power according to local practice.
- Step 4** Connect the office battery and return cables according to the fuse panel engineering specifications.
- Step 5** Affix the power lug on the unit with two screws. Tighten the screws using a torque of 2.7 Nm +/- 0.3 Nm.

Caution A torque level greater than 3.0 Nm may damage the unit.

Use #6AWG cables. Ensure a minimum gap of 50 mm below the chassis, for routing the cables. For ETSI racks, 180-degree power lugs are used to maintain 600 mm footprint.

Figure 6: Connecting DC Power

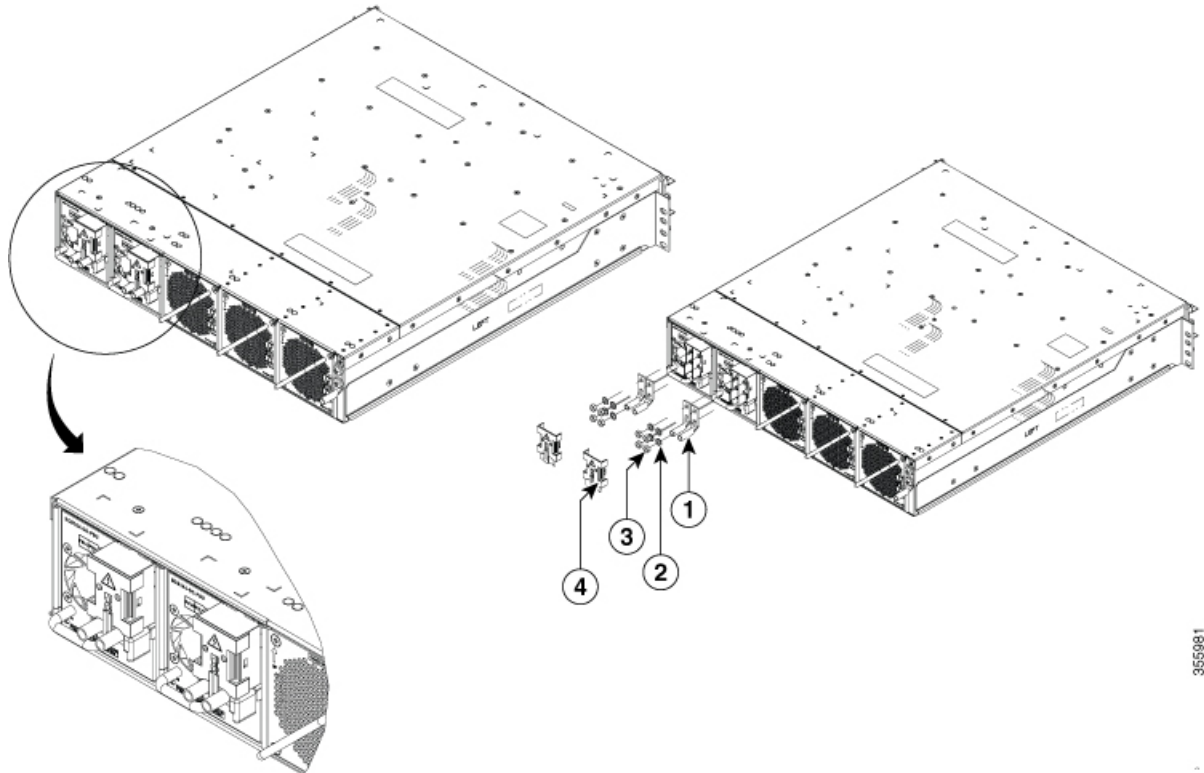

1	Lugs crimped with DC power cords
2,3	Fasteners for DC lugs
4	Protection Cover







- Step 6** Use protection covers to keep the lugs in place.
Snap fit the protection cover towards the top for 90-degree lugs and push it down for straight lugs.

Connect AC Power to NCS 1004



Caution NCS 1004 relies on the protective devices in the building installation to protect against short circuit, overcurrent, and ground faults. Ensure that the protective devices comply with local and national electrical codes.

Figure 7: Rating Label for AC Power

RATINGS AND STATEMENTS FOR AC MAINS POWERED SYSTEM	
PRODUCT RATING (输入): 100-127V~; 15A MAX (2X); 50/60 Hz 200-240V~; 12A MAX (2X); 50/60 Hz	CHARACTÉRISTIQUES DU PRODUIT (输入): 100-127V~; 15A MAX (2X); 50/60 Hz 200-240V~; 12A MAX (2X); 50/60 Hz
 READ USER MANUAL	 LIRE MANUEL D'UTILISATION
 SHOCK HAZARD	 RISQUE D'ÉLECTROCUTION
 CAUTION - THIS UNIT HAS MORE THAN ONE POWER CONNECTION. TURN OFF POWER SOURCE CIRCUIT BREAKERS AND REMOVE ALL CONNECTIONS TO DE-ENERGIZE SYSTEM	 AVERTISSEMENT - CETTE UNITÉ COMPORTE PLUSIEUR RACCORDS D'ALIMENTATION. DÉACTIVEZ L'INTERRUPTEUR D'ALIMENTATION ET DÉBRANCHEZ LE SYSTÈME DE TOUTES LES PRISES POUR LE METTRE HORS TENSION
WARNING - HIGH LEAKAGE CURRENT. EARTH CONNECTION ESSENTIAL BEFORE CONNECTING SUPPLY	AVERTISSEMENT - COURANT DE FUITE ÉLEVÉ. MISE À LA TERRE ESSENTIELLE AVANT DE BRANCHER L'APPAREIL

355972

The voltage rating value for AC power ranges either between 200 V to 240 V or between 100 V to 127 V depending on the standards in various countries.



Note A dual pole breaker is needed for the installation. The rating of the dual pole breaker for each feed is 16A for input voltage 200 Vac to 240 Vac, and 20A for input voltage 100 Vac to 127 Vac.

- Step 1** Verify that the AC cable is installed in the correct AC source panel. Ensure that either the fuse is removed or the circuit breaker is in the off position and locked out.
- Step 2** Attach the AC power cable to the cable connector in the AC power module.
- Note** Ensure that there is a minimum gap of 50 mm for routing the cables. Use a 90-degree exit cable to maintain a footprint of 600 mm for ETSI racks.
- Step 3** Close the cable retention clips to secure the power cables and to prevent their accidental removal.

Figure 8: Connecting 90-degree Power Cable

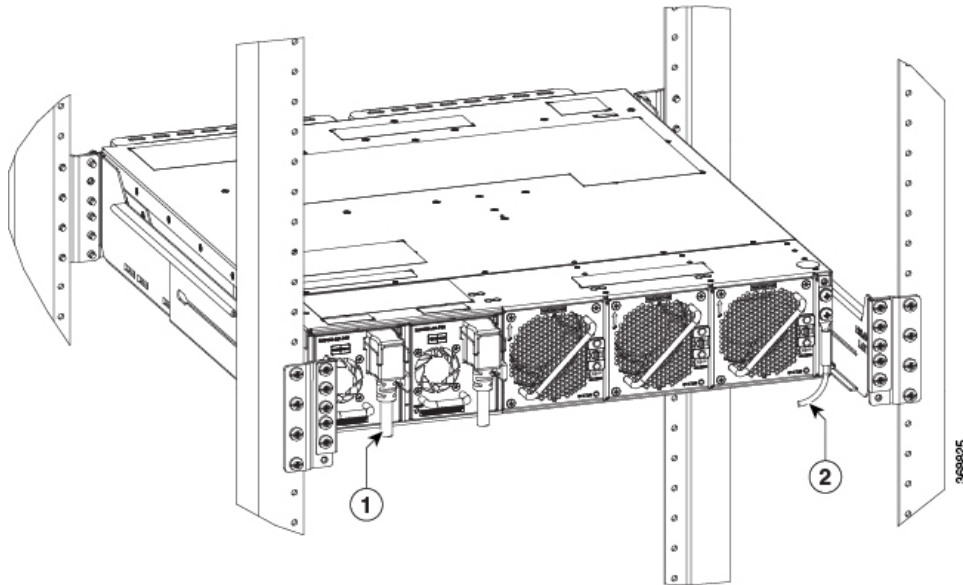

1	90-degree exit cables
2	180-degree ground lug

Figure 9: Connecting Straight Power Cable

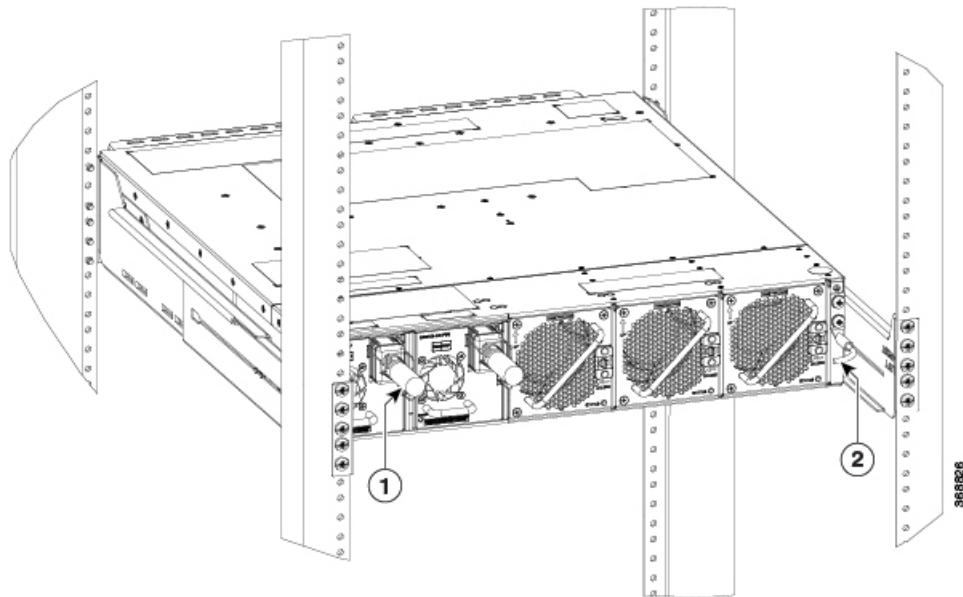

1	Straight exit cables
2	90-degree ground lug

Install Fan Unit

This task has information about installing the fan units into the chassis.



WARNING: DO NOT INTRODUCE BODY OR OBJECT IN THE CHASSIS / PSU / FAN TRAY / LC SLOTS WHEN INSTALLING OR REMOVING A MODULE. EXPOSED CIRCUITRY IS AN ENERGY HAZARD.



ATTENTION: ÉVITEZ TOUT CONTACT ENTRE VOTRE CORPS OU UN OBJET EXTERNE ET L'INTÉRIEUR DU CHÂSSIS, DU BLOC D'ALIMENTATION, LA FENTE DE VENTILATION DU PLATEAU, OU DE LA FENTE PDS LORSQUE VOUS INSTALLEZ OU RETIREZ UN MODULE. LES CIRCUITS EXPOSÉS CONSTITUENT UN RISQUE D'ÉLECTROCUTION.

520496

- Step 1** Orient the fan unit correctly before inserting. Check for the *This Side Up* label.
- Step 2** Holding the handle with one hand and supporting the fan unit with the other hand, insert the fan unit in to the slot on the rear side of the chassis.
- Push the spring loaded lever to the left and hold it in the unlock position (holding position) using your thumb while inserting the fan unit.

Figure 10: Inserting a Fan unit

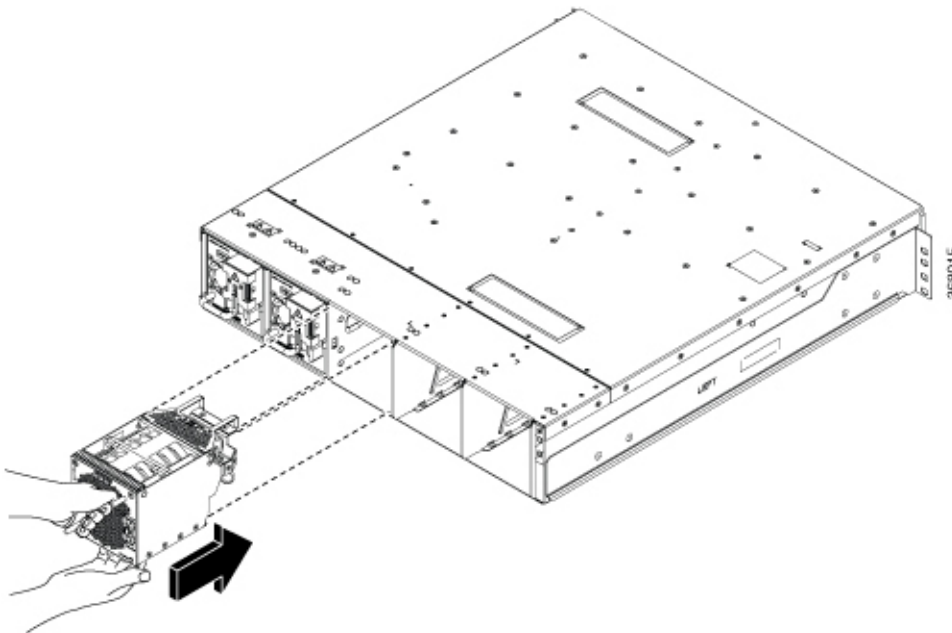

- Step 3** Release the spring-loaded lever to lock the fan unit in its position.

Figure 11: Spring-loaded Lever in Released Condition

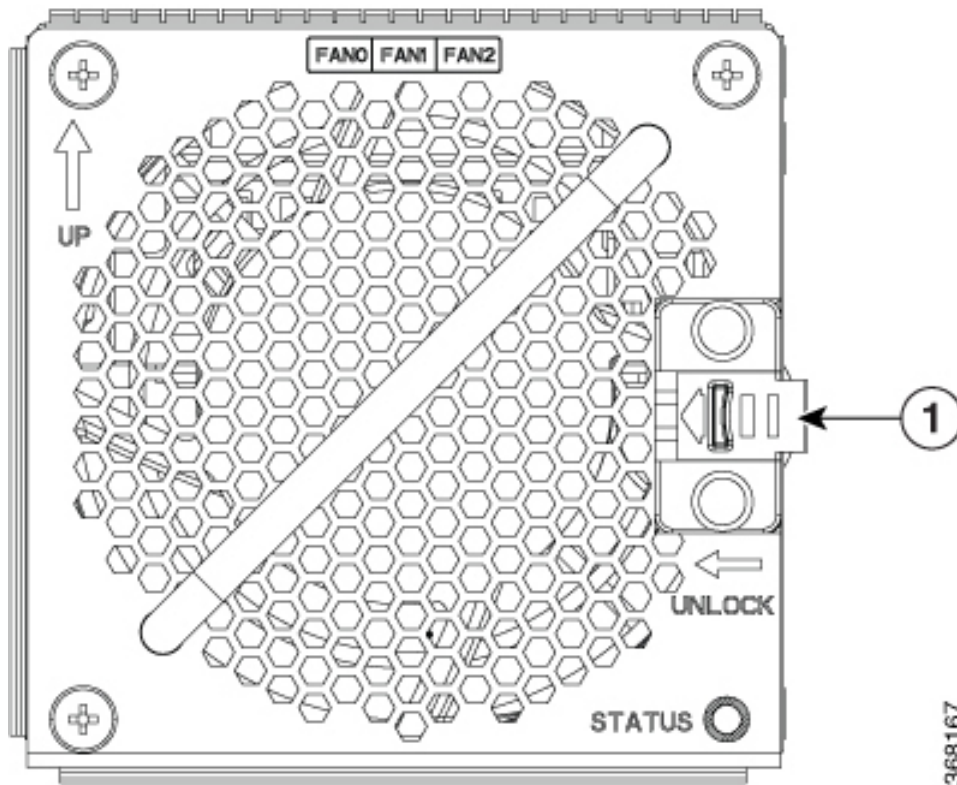

1	Spring-loaded lever
---	---------------------

Attach Fiber Management Bracket

This task has details about attaching a fiber management bracket to a line card or filler card.

- Step 1** Fix the fiber management bracket to the card (line card or filler card, as the case may be).
- Step 2** Using a Torx screwdriver, tighten the two M3 T15 Torx screws of the fiber management bracket to a torque value of 0.65 N-m.
- The procedure to adjust the length of the fiber management bracket is discussed in the subsequent section.

Adjust Fiber Management Bracket of the 1.2T, 1.2TL, 2-QDD-C, and QXP-K9 Line Cards

This task has details about how to adjust the length of the fiber management bracket.



Note We recommend that you maintain the fiber management bracket in the shorter position for ETSI racks, to maintain 600 mm footprint. We also recommend that you adjust the bracket length before the installation.

Step 1 Push the plunger pins downwards on both the sides of the bracket, to disengage the horizontal bar.

Figure 12: Adjusting the Fiber Management Bracket

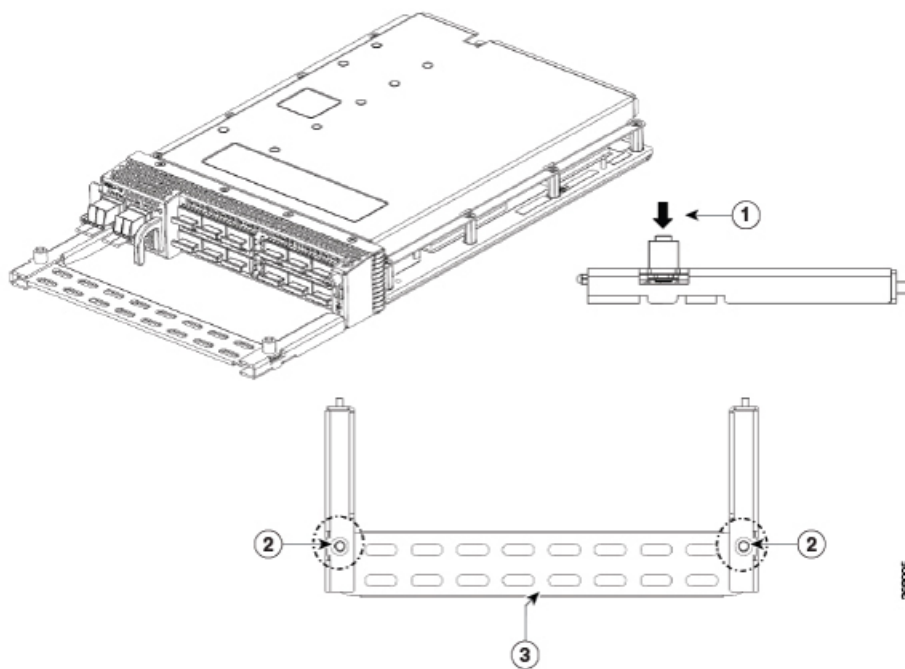

1	Press the plunger pins in the direction, as shown.
2	Plunger pins
3	Horizontal bar

Step 2 Pull the horizontal bar of the fiber management bracket outwards to increase the length of the bracket.

The plunger pins lock the bracket when the horizontal bar is fully extended.

You can verify whether the plunger pins are locked based on the visibility of their grooves.

- If both grooves are visible, the pins are disengaged.

- If no one groove is visible, the bar is in transient stage.
- If one groove is visible, the bar is correctly installed and locked.

Figure 13: Fiber Management Bracket in the Extended Position

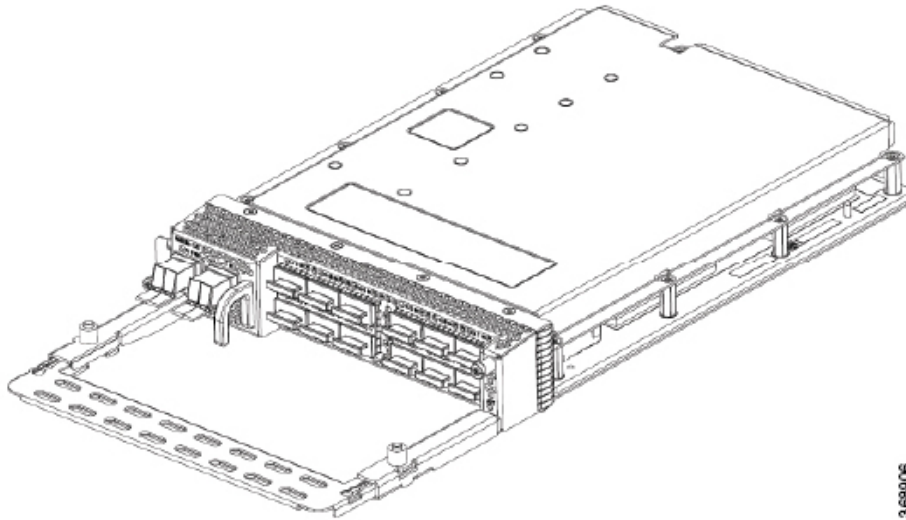

Adjust Fiber Management Bracket of the OTN-XP Line Card

This task has details about how to adjust the length of the fiber management bracket for racks.

Before you begin

It is mandatory to attach the fiber management brackets to the filler cards and line cards before installing the chassis onto a rack. For a detailed procedure, see the [Attach Fiber Management Bracket](#) section.

Using a T15 Torx screwdriver, unscrew and remove the two sets of screws on either side.

Figure 14: Fiber Management Bracket Set

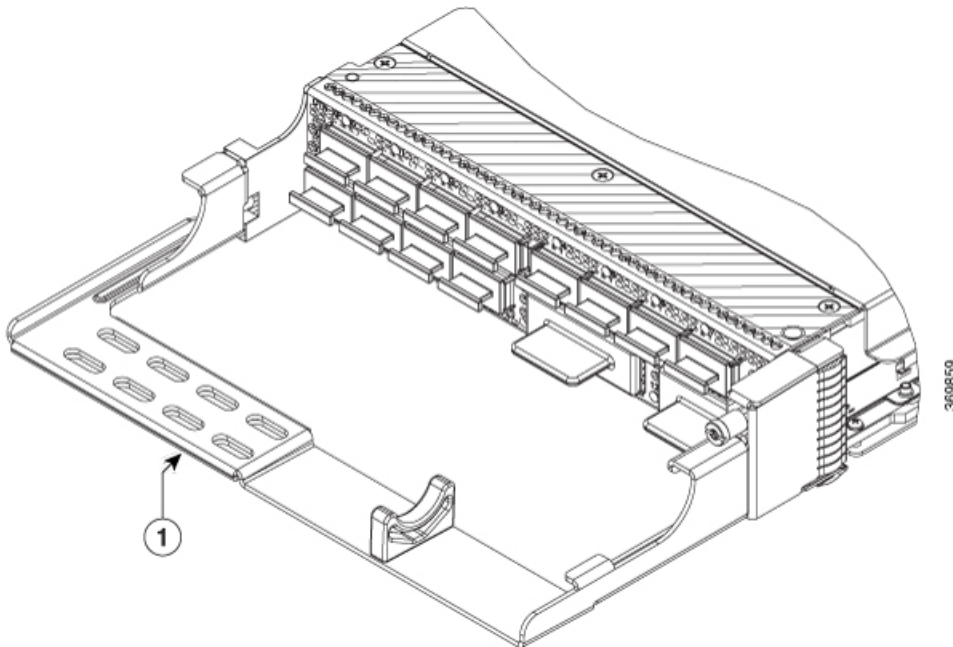

1	Fiber management bracket
---	--------------------------

Install Pluggables

This task has information about installing the pluggables on a line card. The line card is shipped with dust caps.



Caution Protect the line card by inserting dust caps into the pluggable slots when no pluggable is inserted.

Transceivers, fiber-optic cables and optical ports on the line cards must be kept clean and free of dust to maintain high signal accuracy and to prevent damage to the connectors. They must be covered with protection or dust cap when not in use.

- Step 1** Remove the dust plugs.
You can retain and reuse the dust plugs.
- Step 2** Orient the pluggable as shown in the following figure and slide it into the slot.

Figure 15: Inserting QSFP Pluggable (1.2T Line Card)

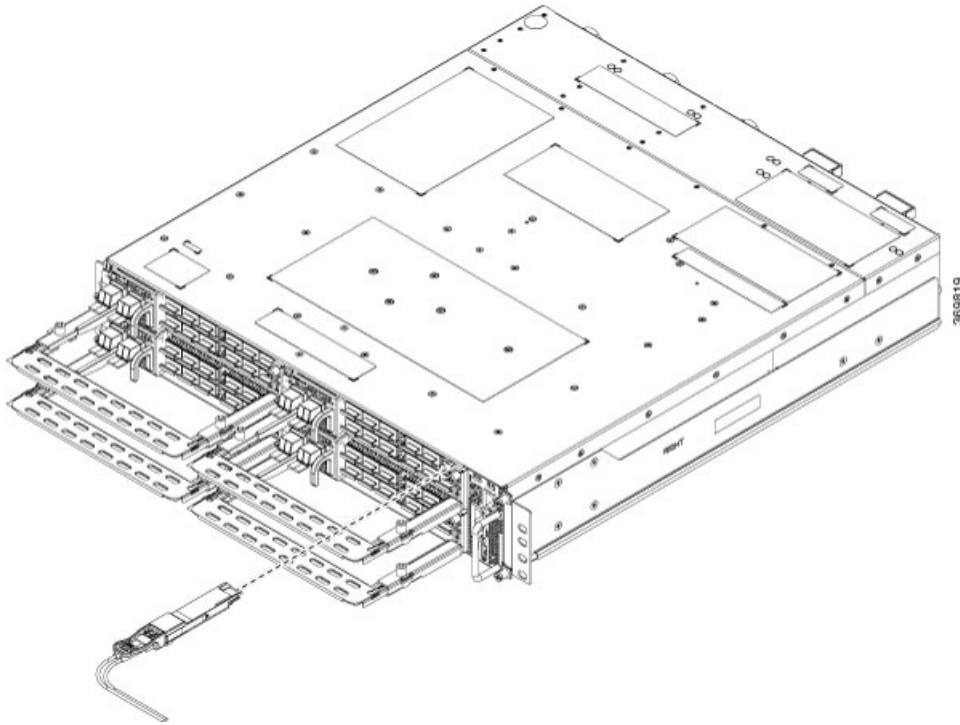
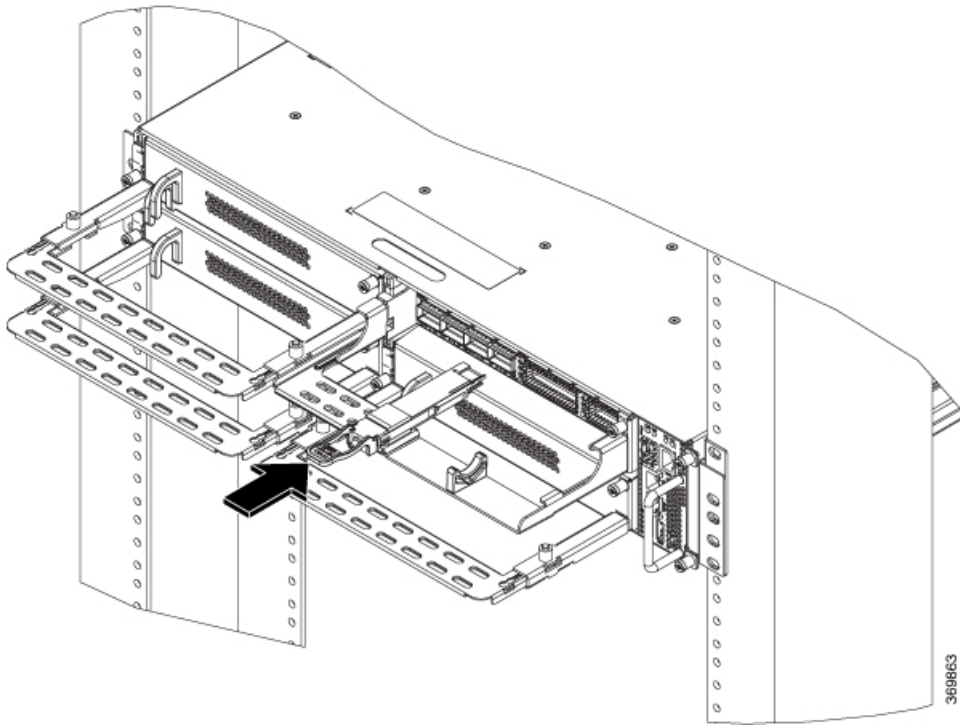
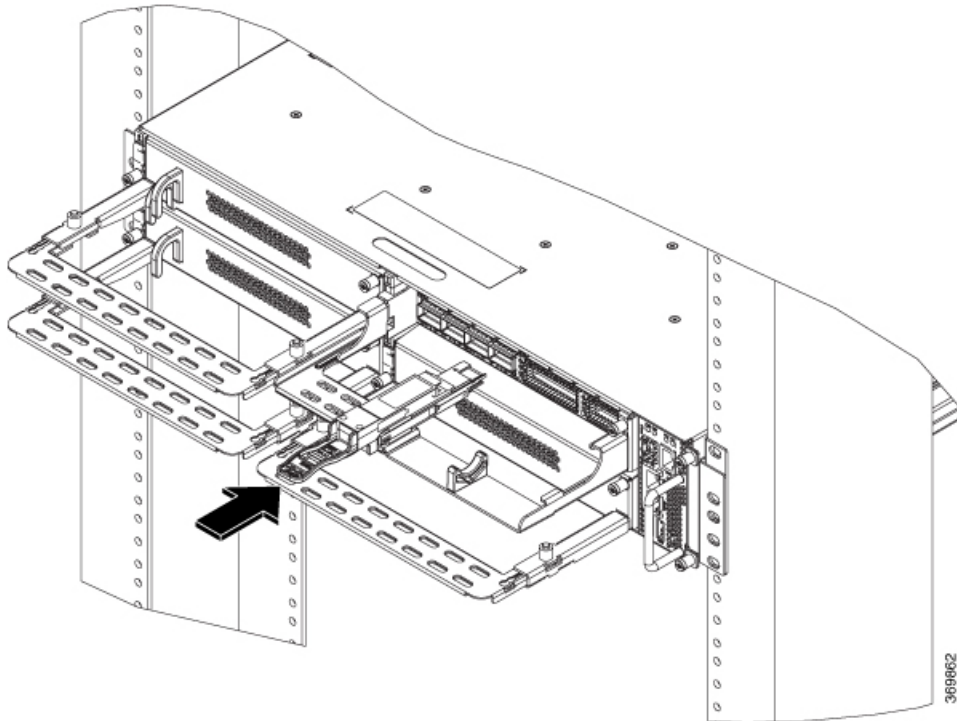

Figure 16: Inserting QSFP-DD Pluggable (OTN-XP Line Card)



Caution The pull tabs of the pluggables must always face down for top rows; the pull tabs of the pluggables must always face up for bottom rows.

Figure 17: Inserting QSFP-28 Pluggable (OTN-XP Line Card)



Do not forcibly push the pluggable into the slot, this might damage the pluggable and/or the slot.

Figure 18: Inserting QSFP-DD Pluggable (QXP-K9 Line Card)

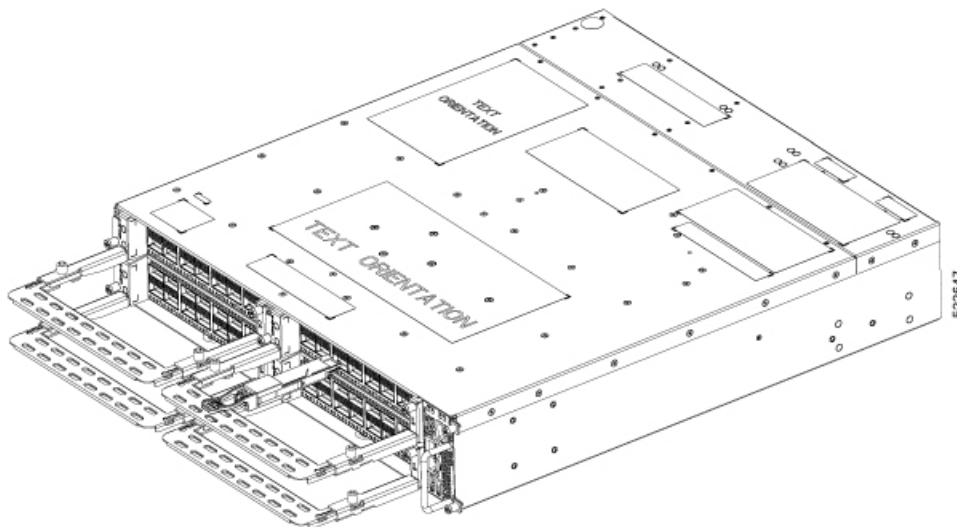

Note Use the push tool to push the QSFP-DD, QSFP-28, and CFP2 pluggables into position as shown below.

Figure 19: Using the Push Tool to Push the Pluggables

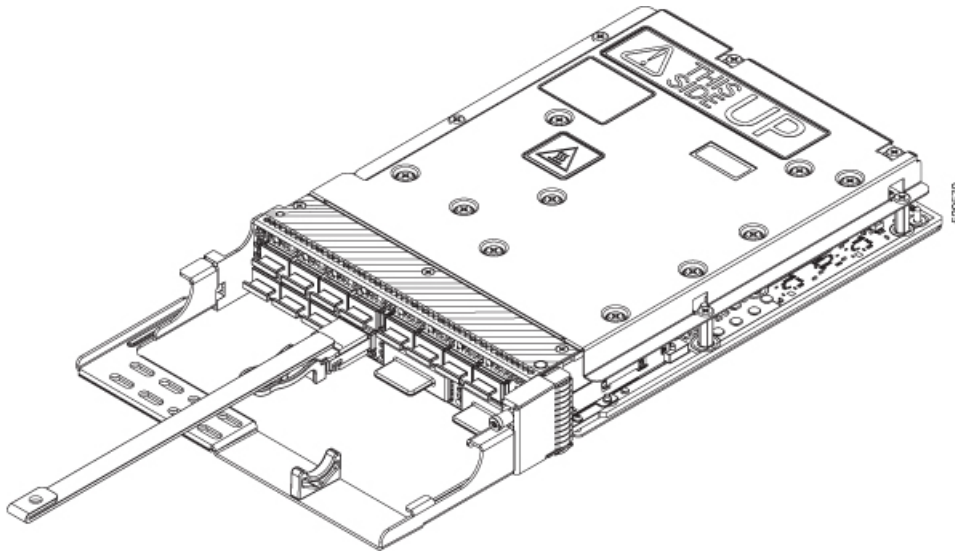

Step 3 Route the cables emerging from the pluggables using the fiber management bracket as shown in the following figure.

Figure 20: Fiber Management Bracket with fibers from Pluggables (1.2T, 1.2TL, 2-QDD-C, and QXP-K9 Line Cards)

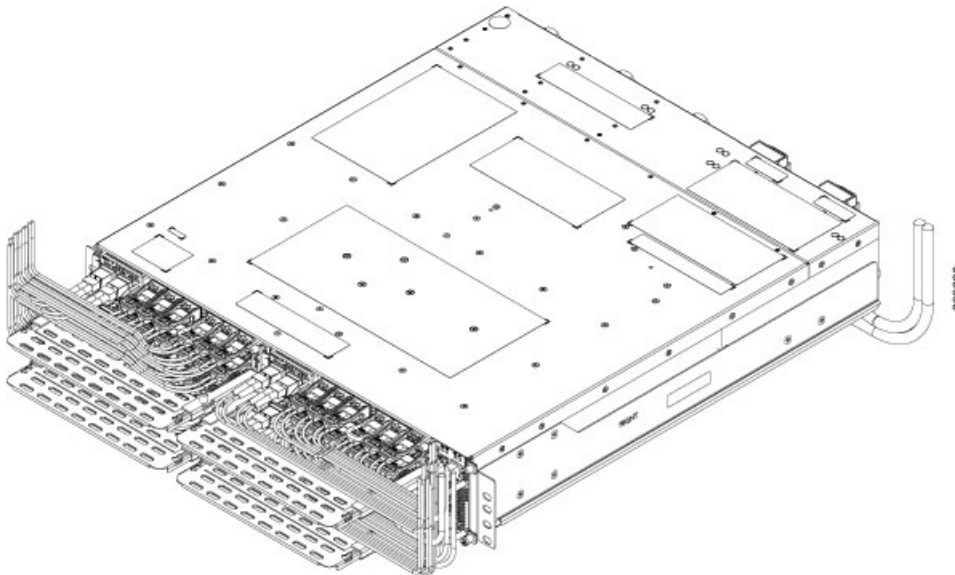
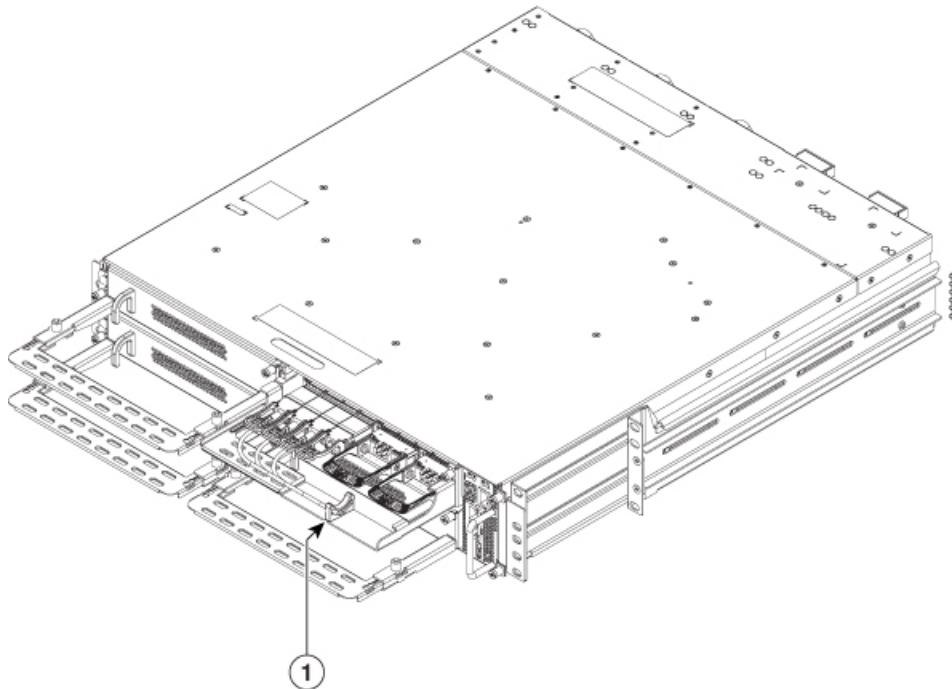

Figure 21: Fiber Management Bracket for the OTN-XP Line Card



1	Fibers from pluggables resting on the cable support bracket
---	---

Guidelines for managing the fibers and cables:

- Use velcro tapes to tie the fibers to the fiber management bracket.
- Fibers from the left line cards should exit from the left and fibers from the right line cards should exit from the right.
- Fibers and cables from the controller should exit from the right. Maintain sufficient slack to extract the controller during OIR.
- Cables from the PSU should exit from the left (when viewed from the rear side).
- Ground cable should exit from the right (when viewed from the rear side).
- For ETSI racks, route the power and the ground cables in the 50 mm space below the chassis, to maintain a chassis footprint of 600 mm.
- Rest the fibers exiting from the pluggables on the cable support bracket. Pass a velcro tape in the gap provided in the cable support bracket to tie the fibers. Ensure that there are no velcro tapes near the CFP2 ports, as this may hinder the insertion and removal of the CFP2 pluggables.

Note The OTN-XP line card supports only the latest optics of QSFP-100G-SR4-S (CPN 10-3142-03 or higher). Older version of optics is not supported.

Air Filter

The air filter removes dust from the air drawn into the chassis by the fan units. If the air filters are damaged, dirty, or clogged with dust, they must be replaced with a new air filter. Failure to replace a compromised air filter can result in insufficient air circulation through the chassis and temperature-related environmental alarms.

The Cisco NCS 1004 air filter has the following components:

- Two air filter side brackets
- One air filter frame
- One air filter

All the three components need to be ordered for first-time installation. The combined PID for all these three components is NCS1K4-FLTR-ASL. The PID for the air filter unit is NCS1K4-FLTR. After first installation of the air filter unit, only the air filter needs to be replaced. The air filter side brackets and the frame can be reused.

First inspection of the air filter must be performed six months after the first installation of the air filter. Air filters must be inspected every three months after the initial six month inspection and replaced if found to be dirty. Cleaned air filters cannot be reused. Replace with a new air filter. It is recommended to have spare air filters in stock.



Note Air filter does not meet the ETSI 600 mm footprint.

Install Air Filter

This task has details about installing the air filter. It is recommended to include the air filter installation as part of the chassis installation.

Precautions while installing air filters

- Ensure that the pull tabs of the pluggables do not get damaged during installation.
- Ensure that the velcro of the fiber management bracket does not interfere with the air filter.
- To remove a chassis, placed in the middle, in a stacked configuration, the air filters of the chassis above and below also need to be removed to avoid accidental scratches on the surface of the chassis.
- Ensure that the cables from the controller exit from the right; maintain sufficient slack to enable easy removal and insertion of the controller during OIR.

Step 1

After the chassis is inserted in the rack, fix the air filter side brackets on either side of the chassis. Check for the arrow indications on the side of the brackets. Using the Philips screws on either side, bind the chassis and the air filter side brackets to the rack. Tighten the Phillips screws (48-101524-01) using a number-2 Phillips screwdriver, to a torque value of 4.65 N-m.

Note In case the air filter is being installed after the chassis installation is completed, then unscrew and remove the four screws (on either side) that bind the chassis to the rack. After fixing the air filter side brackets, only three screws are used on either side, to bind the chassis and air filter side brackets to the rack.

Figure 22: Installing the Air Filter Frame and Side Brackets

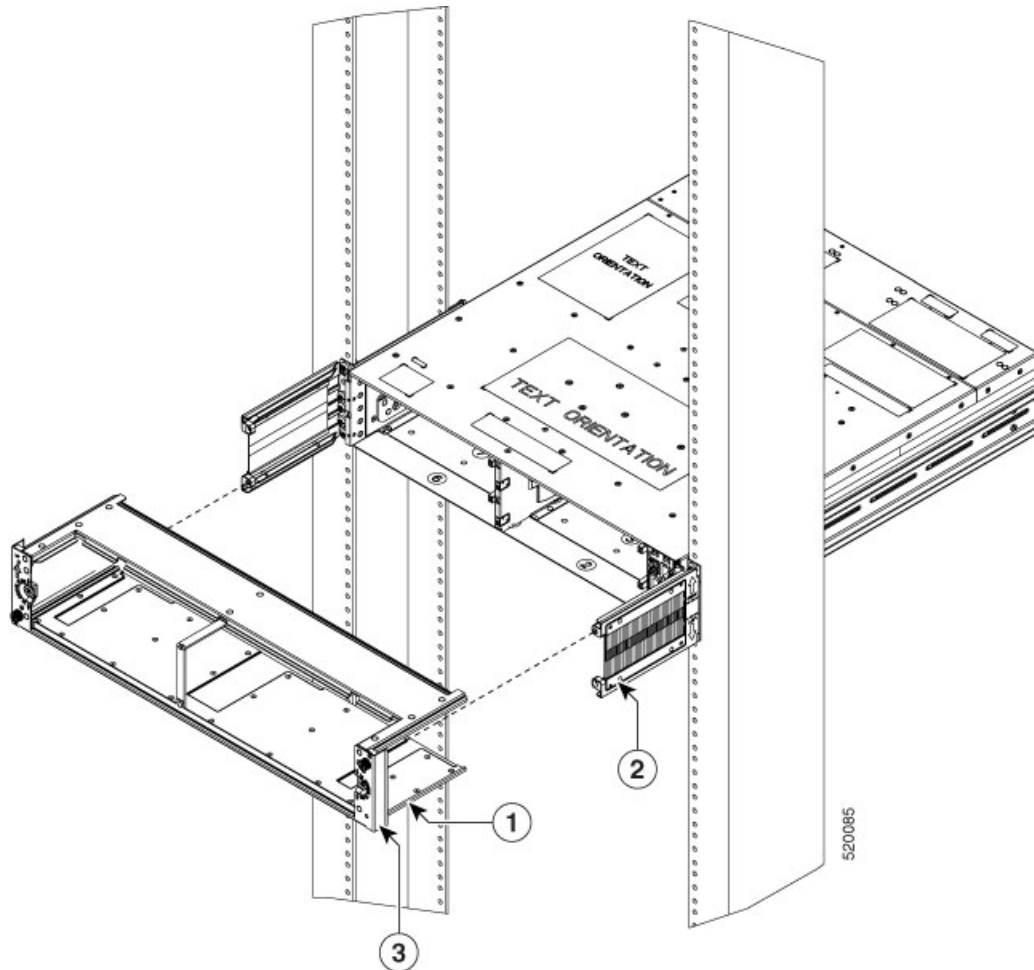

1	Air Filter Frame
2	Air Filter Side Brackets
3	Spare Serial Number label. We recommend that you place the spare label in this location.

Caution Ensure that the air filter frame is tagged to a specific chassis and not mixed with other chassis.

Caution Before placing the spare label on the air filter frame, verify that the serial number on the spare label matches with the serial number on top of the chassis. If the serial numbers do not match, there might be inconsistencies in inventory management.

Figure 23: Installing the Air Filter

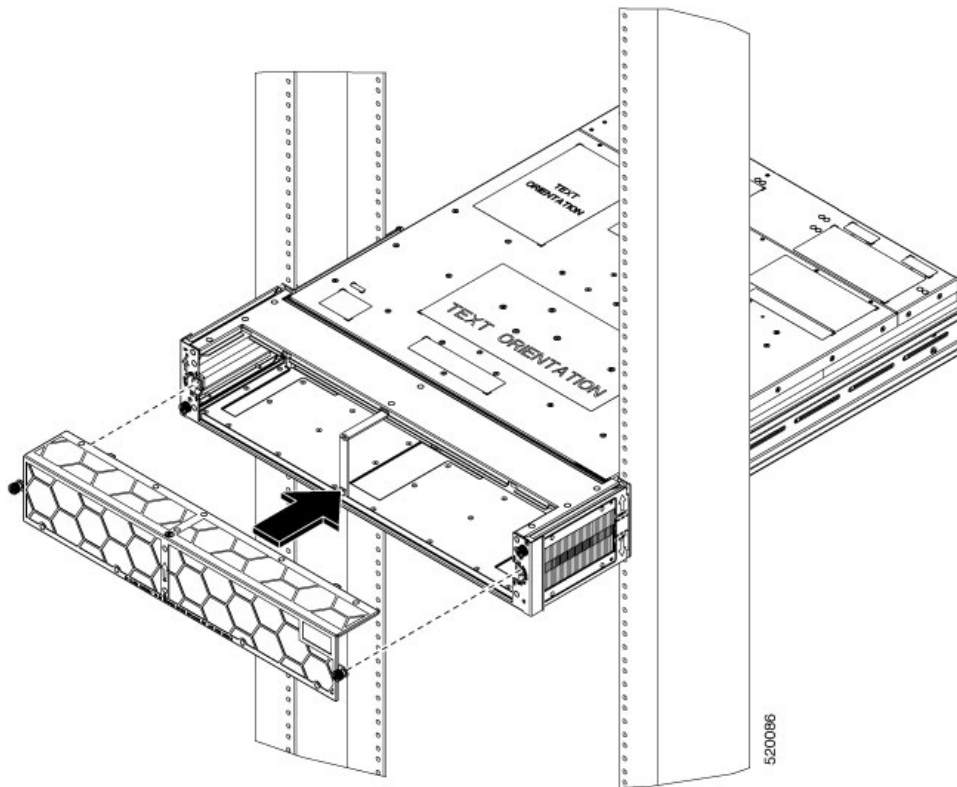

- Step 2** Slide the air filter frame in to the air filter side brackets.
- Step 3** Using a T15 Torx screwdriver, tighten the screw on either side (placed diagonally) to a torque value of 0.65 N-m.
- Step 4** Orient the air filter correctly. The arrow must point upwards.
- Step 5** Push the air filter onto the frame and adjust so that it engages with the edges of the frame.
- Step 6** Using a T15 Torx screwdriver, tighten the screw on either side of the air filter, to a torque value of 0.65 N-m.
-

