



Connecting and Routing the Cables and Wires

This chapter explains how to install the NCS 2002 shelf.

The sections are:

- [NTP-L36 Attaching Wires to Timing, LAN, and Craft Pin Connections in NCS 2002, on page 1](#)

NTP-L36 Attaching Wires to Timing, LAN, and Craft Pin Connections in NCS 2002

Purpose	This procedure attaches wires to the Timing, LAN, and Craft Pin connections in the NCS 2002 shelf.
Tools/Equipment	Twisted #22 or #24 AWG (0.51 mm ² or 0.64 mm ²) shielded wires for LAN or craft 75-ohm coaxial cable with DIN 1.0/2.3 miniature coax connector.
Prerequisite Procedures	NTP-L35 Installing the Power and Ground to the NCS 2002 Shelf
Required/As Needed	As needed
Onsite/Remote	Onsite
Security Level	None



Caution Always use the supplied Electrostatic Discharge (ESD) wristband when working with a powered NCS 2002. For detailed instructions on how to wear the ESD wristband, refer to the [Electrostatic Discharge and Grounding Guide for Cisco NCS 2000 Series](#)



Note To route the copper cables from the SFPs or RJ-45 ports in a NCS 2002 shelf, removal of the shelf door is mandatory.



Note The minimum distance between the fiber LC connector and the bulk attenuator must be at least 50 cm. This is the minimum distance required to place the bulk attenuator outside the shelf from any port of a card.

Procedure

- Step 1** Complete either [DLP-L54 Installing Timing Wires in Cisco NCS 2002 - ANSI, on page 2](#) or [DLP-L55 Installing Timing Wires in Cisco NCS 2002- ETSI, on page 4](#) if you are provisioning external timing.
- Step 2** Complete [DLP-L56 Installing LAN Wires in Cisco NCS 2002, on page 9](#) to create an external LAN connection. You must connect a CAT-5 Ethernet cable to the LAN port on the TNC/TNCE/TSC/TSCE card to create an external LAN connection.

Stop. You have completed this procedure.

DLP-L54 Installing Timing Wires in Cisco NCS 2002 - ANSI

Purpose	This task installs the timing wires in the DC-2 or AC-2 Power Module of NCS 2002 (ANSI).
Tools/Equipment	100-ohm wire wrap cable, wire wrap tool
Prerequisite Procedures	None
Required/As Needed	As needed
Onsite/Remote	Onsite
Security Level	None

Procedure

- Step 1** Locate the timing BITS connectors in the DC-2 or AC-2 Power Module, as shown in the figures below .

Figure 1: DC-2 Power Module ANSI BITS connectors

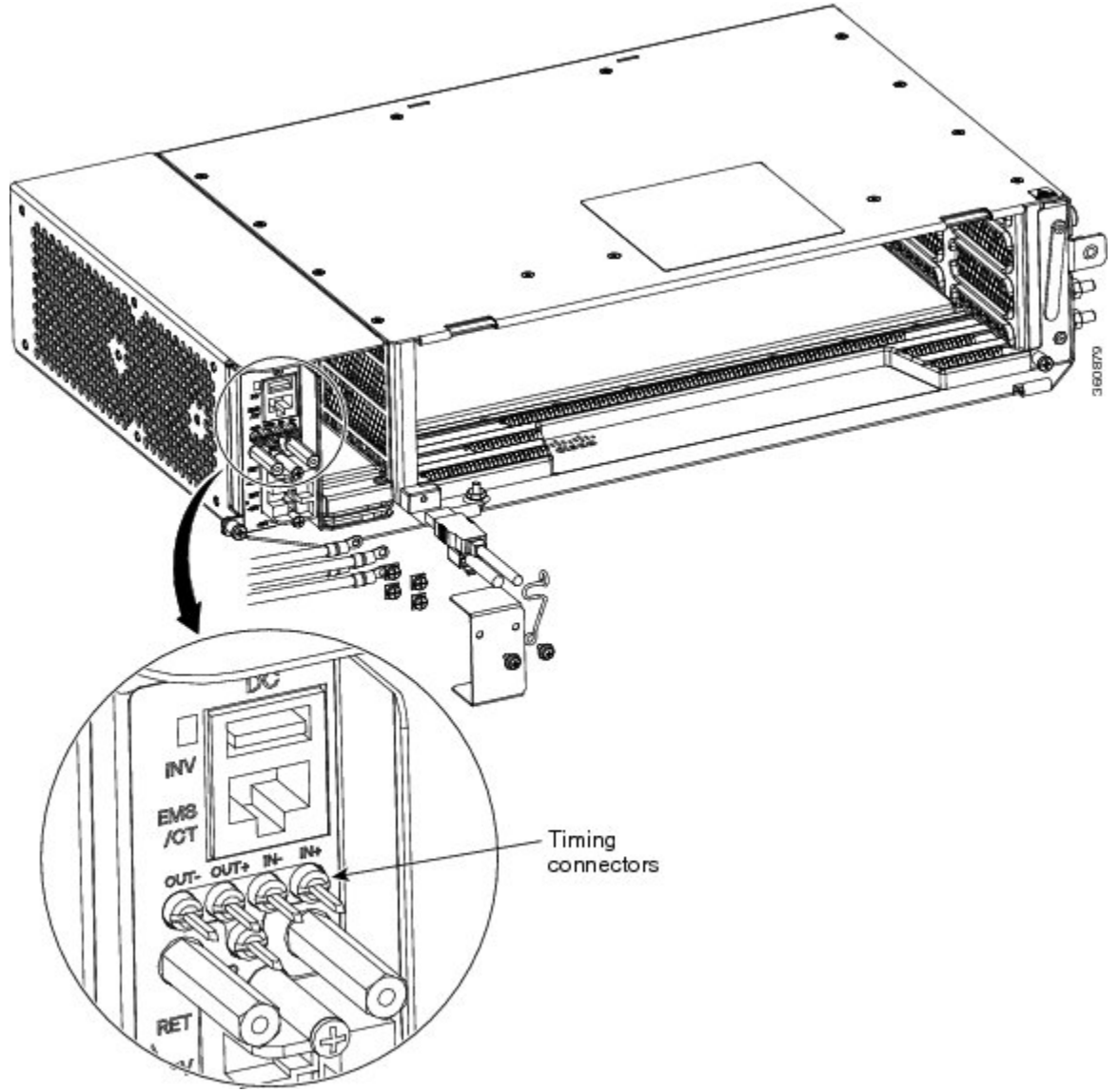
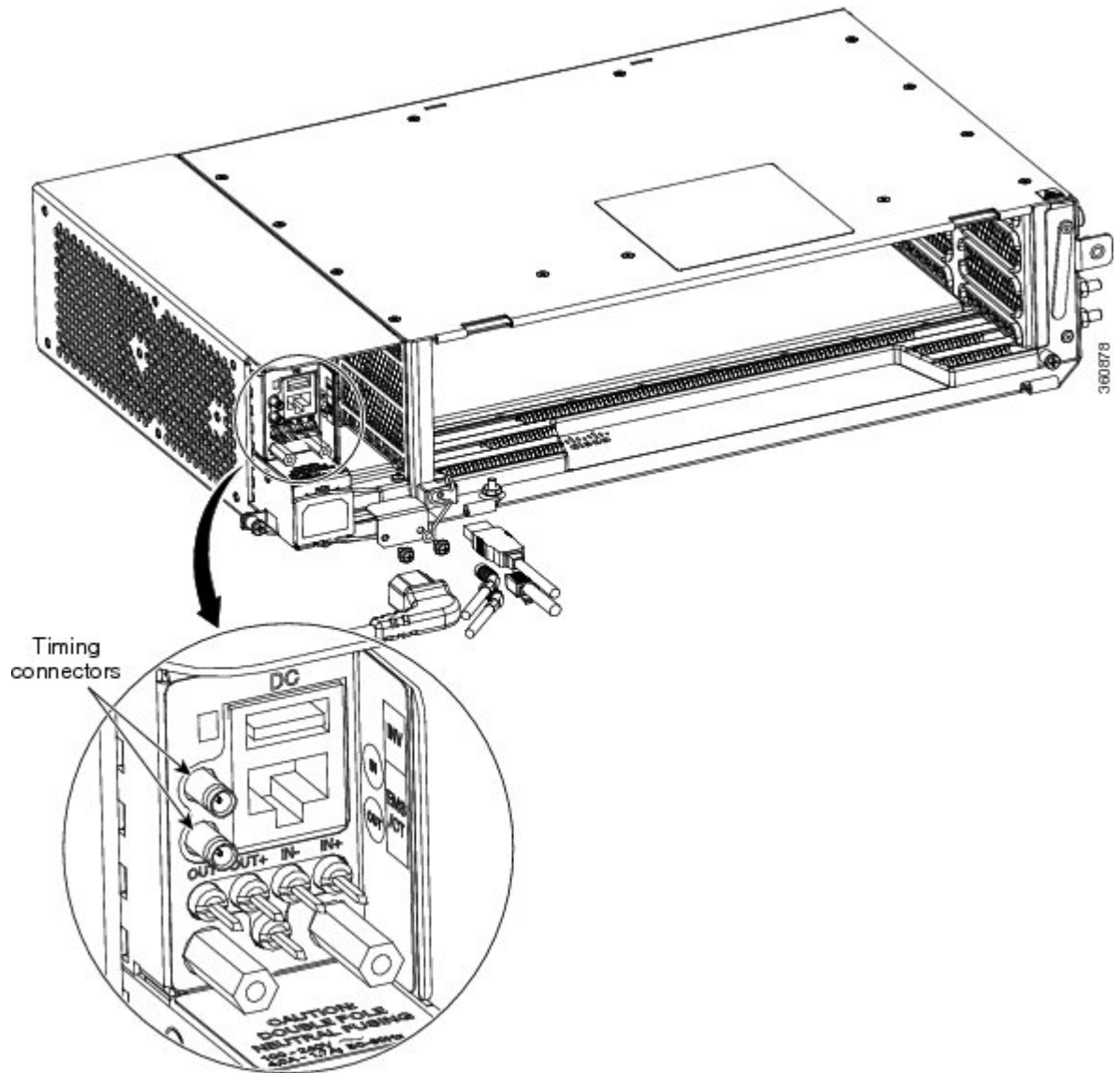

Figure 2: AC-2 Power Module ANSI BITS Connectors



Step 2 Connect the wire wrap cable to the appropriate timing connector in the Power Module.

Step 3 Connect the other end of the cable to the external source of the timing.

Repeat this step for each cable that is needed.

Step 4 Return to your originating procedure (NTP).

DLP-L55 Installing Timing Wires in Cisco NCS 2002- ETSI

Purpose	This task installs the timing wires in the AC-2 or DC-2E Power Module of NCS 2002 (ETSI).
----------------	---

Tools/Equipment	75-ohm coaxial cable with a DIN 1.0/2.3 miniature coax connector. The PID for the BITS IN/OUT cable is 15454-M-TMGCBL=.
Prerequisite Procedures	None
Required/As Needed	As needed
Onsite/Remote	Onsite
Security Level	None

Procedure

- Step 1** Locate the timing BITS connectors in the DC-2E or AC-2 Power Module, as shown in the figures below.

Figure 3: DC-2E Power Module ETSI BITS Connectors

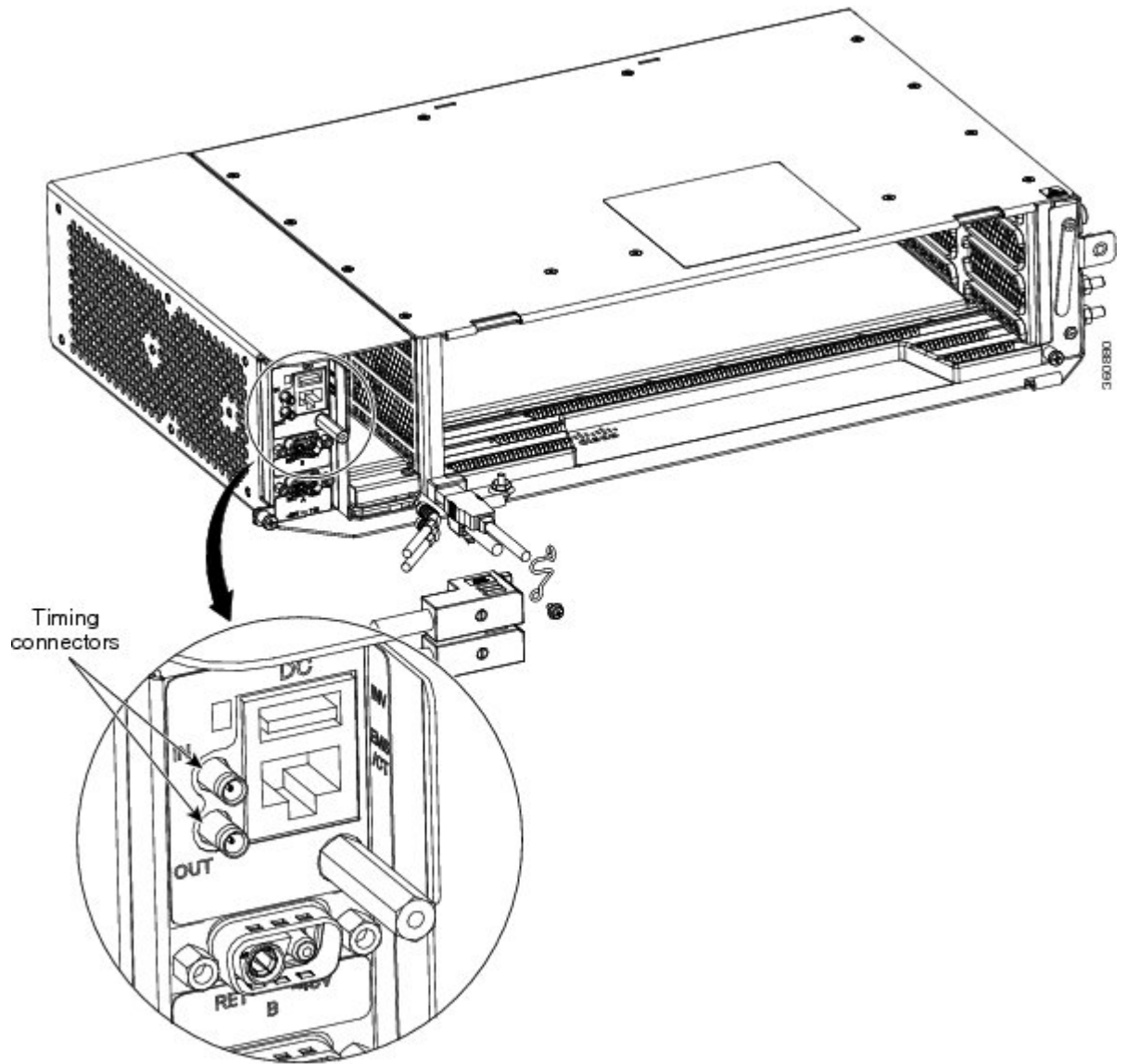
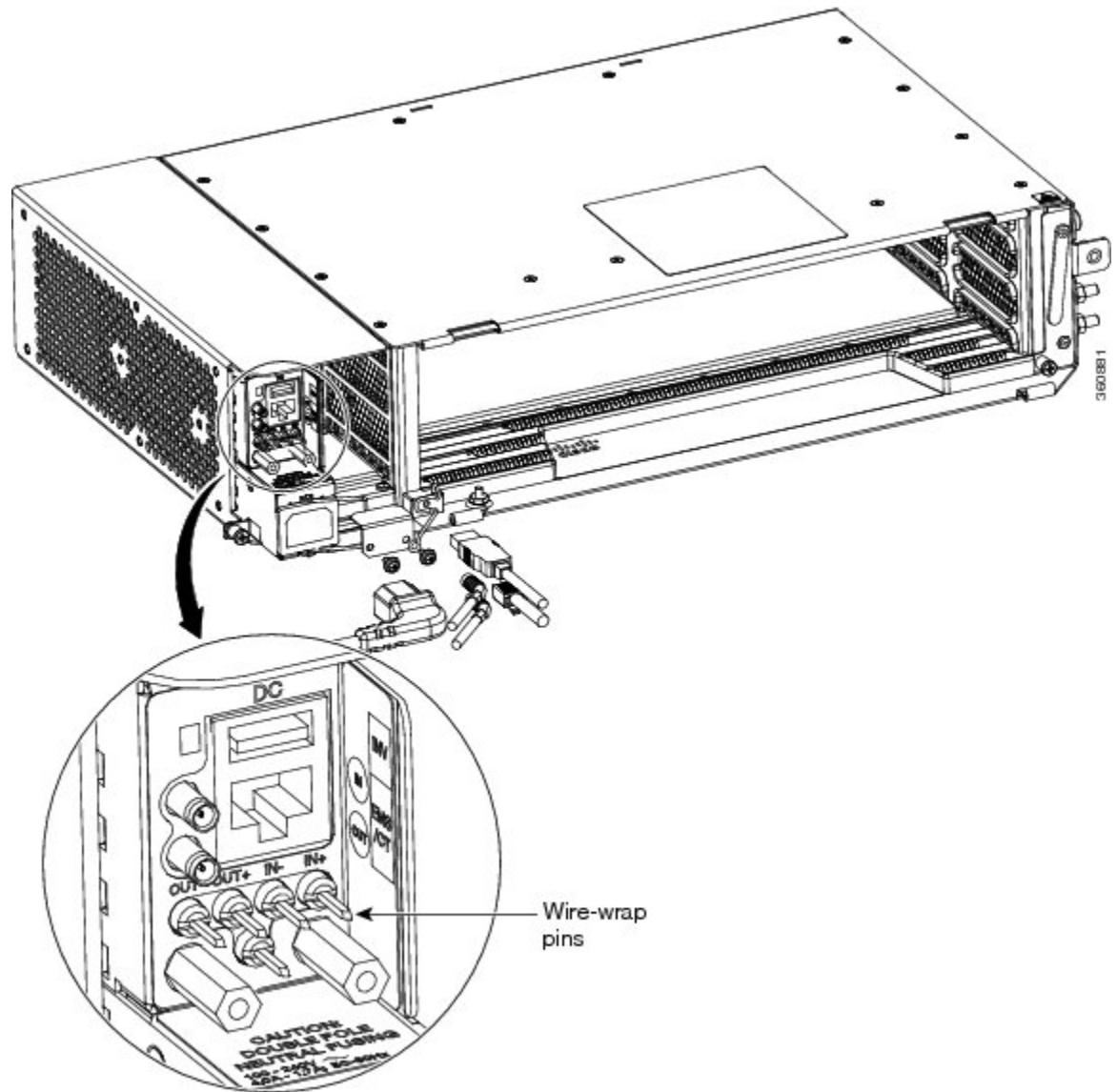

Figure 4: AC-2 Power Module ETSI BITS Connectors



- Step 2** Using a coaxial cable with DIN 1.0/2.3 miniature coax connectors, connect the clock cable to the appropriate connector in the Power Module.
- Step 3** Gently push the cable with the DIN 1.0/2.3 miniature coax connector down until the cable connector slides into the DIN 1.0/2.3 miniature coax connector on the Power Module with a click. The Power Module provides DIN 1.0/2.3 miniature coax connectors that are used for timing input and output. The input connectors for timing provide a 75-ohm termination. System cables that can convert timing clocks from 75 ohms to 100/120 ohms are available.
- Note** See ITU-T G.813 for rules about provisioning timing references.
- Step 4** Connect the other end of the cable to the external source of the timing.
Repeat this step for each cable that is needed.

Step 5 Return to your originating procedure (NTP).

Installing Timing Wires in the Modular DC Power Module

Use this task to install the timing wires in the DC frame of the new DC power module.

Purpose	This task installs the timing wires in the modular DC Power Module of NCS 2002.
Tools/Equipment	75-ohm coaxial cable with a DIN 1.0/2.3 miniature coaxial connector. The PID for the BITS IN/OUT cable is 15454-M-TMGCBL=.
Prerequisite Procedures	None
Required/As Needed	As needed
Onsite/Remote	Onsite
Security Level	None

Procedure

Step 1 Locate the timing BITS connectors in the modular DC power module, as shown in the figure below.

Figure 5: Modular DC-2 Power Module BITS Connectors

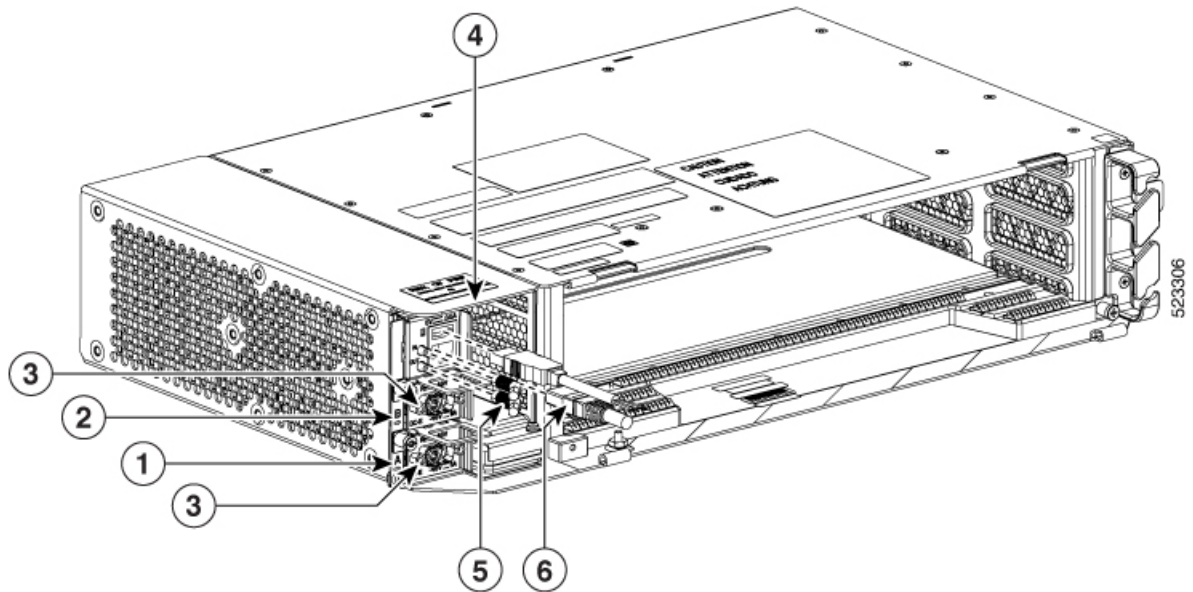

1	PSU A
2	PSU B
3	ETSI PSUs

4	Captive screws
5	Coaxial cables
6	Ethernet cable

- Step 2** Using a coaxial cable with DIN 1.0/2.3 miniature coaxial connectors, connect the clock cable to the appropriate connector in the Power Module.
- Step 3** Gently push the cable with the DIN 1.0/2.3 miniature coaxial connector down until the cable connector slides into the DIN 1.0/2.3 miniature coaxial connector on the Power Module with a click. The Power Module provides DIN 1.0/2.3 miniature coaxial connectors that are used for timing input and output. The input connectors for timing provide a 75-ohm termination. System cables that can convert timing clocks from 75 ohms to 100/120 ohms are available.
- See ITU-T G.813 for rules about provisioning timing references.
- Step 4** Connect the other end of the cable to the external source of the timing.
- Repeat this step for each cable that is needed.
- Step 5** Return to your originating procedure (NTP).

DLP-L56 Installing LAN Wires in Cisco NCS 2002

Purpose	This task installs the LAN wires in NCS 2002.
Tools/Equipment	Standard CAT-5 Ethernet cable straight-through for data terminal equipment (DTE) or crossover for data circuit-terminating equipment (DCE) or RJ-45 connector Crimping tool for RJ-45 connector 0.51 mm ² or 0.64 mm ² (#22 or #24 AWG) wire, preferably standard CAT-5
Prerequisite Procedures	NTP-L35 Installing the Power and Ground to the NCS 2002 Shelf
Required/As Needed	As needed
Onsite/Remote	Onsite
Security Level	None

Procedure

- Step 1** Using a 0.51 mm² or 0.64 mm² (#22 or #24 AWG) wire or a standard CAT-5 Ethernet cable, connect the wires to the RJ-45 connector.
- Step 2** Return to your originating procedure (NTP).

