



Cisco Optical Network Planner Configuration Guide, Release 4.1

First Published: 2021-02-16

Last Modified: 2023-06-22

Americas Headquarters

Cisco Systems, Inc.
170 West Tasman Drive
San Jose, CA 95134-1706
USA
<http://www.cisco.com>
Tel: 408 526-4000
800 553-NETS (6387)
Fax: 408 527-0883

THE SPECIFICATIONS AND INFORMATION REGARDING THE PRODUCTS IN THIS MANUAL ARE SUBJECT TO CHANGE WITHOUT NOTICE. ALL STATEMENTS, INFORMATION, AND RECOMMENDATIONS IN THIS MANUAL ARE BELIEVED TO BE ACCURATE BUT ARE PRESENTED WITHOUT WARRANTY OF ANY KIND, EXPRESS OR IMPLIED. USERS MUST TAKE FULL RESPONSIBILITY FOR THEIR APPLICATION OF ANY PRODUCTS.

THE SOFTWARE LICENSE AND LIMITED WARRANTY FOR THE ACCOMPANYING PRODUCT ARE SET FORTH IN THE INFORMATION PACKET THAT SHIPPED WITH THE PRODUCT AND ARE INCORPORATED HEREIN BY THIS REFERENCE. IF YOU ARE UNABLE TO LOCATE THE SOFTWARE LICENSE OR LIMITED WARRANTY, CONTACT YOUR CISCO REPRESENTATIVE FOR A COPY.

The Cisco implementation of TCP header compression is an adaptation of a program developed by the University of California, Berkeley (UCB) as part of UCB's public domain version of the UNIX operating system. All rights reserved. Copyright © 1981, Regents of the University of California.

NOTWITHSTANDING ANY OTHER WARRANTY HEREIN, ALL DOCUMENT FILES AND SOFTWARE OF THESE SUPPLIERS ARE PROVIDED "AS IS" WITH ALL FAULTS. CISCO AND THE ABOVE-NAMED SUPPLIERS DISCLAIM ALL WARRANTIES, EXPRESSED OR IMPLIED, INCLUDING, WITHOUT LIMITATION, THOSE OF MERCHANTABILITY, FITNESS FOR A PARTICULAR PURPOSE AND NON-INFRINGEMENT OR ARISING FROM A COURSE OF DEALING, USAGE, OR TRADE PRACTICE.

IN NO EVENT SHALL CISCO OR ITS SUPPLIERS BE LIABLE FOR ANY INDIRECT, SPECIAL, CONSEQUENTIAL, OR INCIDENTAL DAMAGES, INCLUDING, WITHOUT LIMITATION, LOST PROFITS OR LOSS OR DAMAGE TO DATA ARISING OUT OF THE USE OR INABILITY TO USE THIS MANUAL, EVEN IF CISCO OR ITS SUPPLIERS HAVE BEEN ADVISED OF THE POSSIBILITY OF SUCH DAMAGES.

Any Internet Protocol (IP) addresses and phone numbers used in this document are not intended to be actual addresses and phone numbers. Any examples, command display output, network topology diagrams, and other figures included in the document are shown for illustrative purposes only. Any use of actual IP addresses or phone numbers in illustrative content is unintentional and coincidental.

All printed copies and duplicate soft copies of this document are considered uncontrolled. See the current online version for the latest version.

Cisco has more than 200 offices worldwide. Addresses and phone numbers are listed on the Cisco website at www.cisco.com/go/offices.

Cisco and the Cisco logo are trademarks or registered trademarks of Cisco and/or its affiliates in the U.S. and other countries. To view a list of Cisco trademarks, go to this URL: <https://www.cisco.com/c/en/us/about/legal/trademarks.html>. Third-party trademarks mentioned are the property of their respective owners. The use of the word partner does not imply a partnership relationship between Cisco and any other company. (1721R)

© 2020 Cisco Systems, Inc. All rights reserved.



CONTENTS

CHAPTER 1

Get Started with Cisco Optical Network Planner 1

- Cisco Optical Network Planner Overview 1
- Supported Platforms 2
- Supported Topologies 2
- Supported Protection Schemes 3
- Supported Services 4
- Supported DWDM Channel Interfaces 5
- Supported Fiber Types 5
- Register New User 5
- Log in to Cisco ONP Web Interface 6
- Cisco ONP Home Page 6
- Change Password 6
- Reset Your Password 7
- Sign Out from Cisco ONP 7
- Cisco Secure Development Lifecycle Compliance 8

CHAPTER 2

Manage Users and Roles 9

- User Roles in Cisco ONP 9
- Grant Access to a New User 10
- Remove Access to a User 11
- Delete a User 11
- Create a New User Group 12
- Assign a User to a User Group 12
- Set Password Expiration for Individual User 13
- Set Password Expiration for All Users 14
- Lock and Unlock an Individual User Account 14

Expire the Password Set by an Individual User	15
Create a New Role	15
Assign a Role to a User Group	16
Manage Password Through Dictionary	16
Retrieve System Logs	17

CHAPTER 3
Design and Analyze Networks 19

Design a Network Using Cisco ONP	19
Manually Design a Network Using Cisco ONP	20
Create Shared Risk Link Group	21
Import Network Using Excel Sheet	22
Cisco Transport Planner Network Import Support	23
Import MPZ Design File	23
Export the CPZ File	24
Import CPZ File	25
Live Network Import	26
Perform Live Network Import	26
Ports Used in LNI	30
Supported Hardware and Software for LNI	31
Limitations of LNI	33
Create Optical Subnet for Non-SSON Networks	34
Create Optical Subnet for SSON Networks	35
Convert Non-SSON Network to SSON Network	36
Share a Network	37
Access a Shared Network	38
Unshare a Network	38
Analyze the Network	39
Bottom-Up Flow	40
Idle Timeout in the Analyze Mode	40
Upgrade the Analyzed Network	40
Upgrade LNI Network	42
Media Channel Unlocking Scenarios	44
Possible Error Scenarios and the Workarounds	44
Upgrade the Software Release of a Network	46

Plan Mode	48
Enter the Plan Mode	48
Exit the Plan Mode	48
Fail a Fiber	49
Undo Fiber Failure	49
Create a Failure Set	50
Fail a Site	50
Undo Site Failure	51
Failure Report	51
Export Failure Report	52
Export Failure Report from Map	52
Restore Failed Channels	53
Import Alien	53
Download Alien	54
Delete Alien	54
Layout Template	55
Export Layout Template	55
Import Layout Template for NCS 2000 Network in to Cisco ONP Database	56
Download Layout Template for NCS 2000 Network	57
Delete Layout Template for NCS 2000 Network	57
Apply NCS 2000 Layout Template into a Site	57
Import NCS 1000 and NCS 4000 Layout Template into NCS1K-2K and NCS4K-1K-2K Sites	58
Layout Visualization	59
View Network Layout	59
Edit the Layout Manually	60
View the Layout Details Using Tooltip	60
Copy the Configurations of a Particular Node to Another Node	61
Export Port Usage of LNI Network	62
Regenerate BoM Automatically	63
Add new Pluggables, Alarm Cables and 100G Client Bandwidth Licenses to BoM	63
Export IPC Report	64
Design Networks with SVO Card	64
Associate OLA or DGE Sites with SVO Cards	65
Upload NETCONF XML Files on SVO Web Interface	66

Export NETCONF XML Files for Individual Sites 66

CHAPTER 4

Modify Network Properties 69

Modify Network Properties 69

Modify Site Properties 72

Add Contentionless Side to a Site 80

Modify Number of Contentionless Side Ports for a Site 81

Modify Fiber Properties 82

Modify Fiber Couple Properties 86

Modify Service Properties 87

Services Aggregation 90

Create a New Service Group 90

Modify Service Group Properties 91

Aggregation Rules 92

Associate a Service to the Newly Created Group 93

Export Aggregation Reports 94

Modify Wave Properties 94

Modify Media Channel Properties 94

Modify Trail Properties 96

Modify Section Properties 98

Modify Side Properties 99

Modify C-Band Amplifier Properties 100

Sort the Network Elements 105

Regeneration Support 105

Create a Regeneration Site 105

Multidegree ROADM 106

CHAPTER 5

View Network Reports 109

Network Reports 109

View Reports in the Dashboard Tab 109

View Reports in the Elements Tab 110

View Details of the BOM Report 111

View Details of Layout and Internal Connections 111

Export Internal Connections 112

Compare the Installation Parameters of Two Networks 112

Compare the Optical Report of Two Networks 113

View Optical Results 113

Confidential Banner 119

CHAPTER 6

Backup and Restore Cisco ONP Database 121

Backup Database 121

Setup Backup 121

Perform Manual Backup 122

Schedule a Backup 122

Schedule a Backup Using Script 122

Schedule a Backup 122

Syntax to Schedule the Backup Using Crontab 123

Restore Database Manually 123

Restore Database Using Script 125

APPENDIX A

Cisco ONP UI Reference 127

Menu Bar 127

File 128

Network 128

Export 129

Import 129

Manage 130

Logs 130

Job Monitor 131

Control Panel 132

Help 132

Network Tree 133

Design Palette 134

Entity Editor 136

APPENDIX B

Supported Cards and Pluggables 139

Supported Transponder Cards and Pluggables 139

APPENDIX C	Supported Aliens	151
	Supported Aliens	151

APPENDIX D	Supported Amplifiers	153
	Supported Amplifiers	153



CHAPTER 1

Get Started with Cisco Optical Network Planner

- [Cisco Optical Network Planner Overview, on page 1](#)
- [Supported Platforms, on page 2](#)
- [Supported Topologies , on page 2](#)
- [Supported Protection Schemes , on page 3](#)
- [Supported Services, on page 4](#)
- [Supported DWDM Channel Interfaces, on page 5](#)
- [Supported Fiber Types, on page 5](#)
- [Register New User, on page 5](#)
- [Log in to Cisco ONP Web Interface, on page 6](#)
- [Cisco ONP Home Page, on page 6](#)
- [Change Password , on page 6](#)
- [Reset Your Password, on page 7](#)
- [Sign Out from Cisco ONP, on page 7](#)
- [Cisco Secure Development Lifecycle Compliance, on page 8](#)

Cisco Optical Network Planner Overview

Cisco Optical Network Planner (Cisco ONP) is a tool to model and test Optical Transport Networks (OTN) and Dense Wavelength Division Multiplexing (DWDM) optical networks by using a graphical environment. The primary purpose of Cisco ONP is to design and validate networks of NCS 1004, NCS 2000, and NCS 4000 series. Using the Cisco ONP tool, you create multiple instances of a network, modify different parameters at each instance, and compare. Cisco ONP generates a rack view of all the sites that are deployed in the network, shows the differences between the instances, and provides a complete Bill of Materials (BoM) for the network.

Cisco ONP models the network, generates the BoM, and provides detailed information about the network, such as Connection report, Optical report, and Traffic matrix.

This chapter describes the features of Cisco ONP, protection scenarios, topology and service support, CSDL (Cisco Secure Development Lifecycle) compliance, and the setting up of the graphical display.

For more information about Cisco ONP, see the [data sheet](#).

Supported Platforms

Cisco ONP supports the following platforms:

Table 1: Supported Platforms and Releases

Platforms	Recommended and Supported Releases
NCS 1004	7.0.1
NCS 2000	11.0.0, 11.1.0, 12.0.1, 12.1.0
NCS 4000	6.5.28

Supported Topologies

Cisco ONP supports the following network topologies:

- **Linear**—In a linear topology, the nodes are arranged in a line and are connected to two other adjacent nodes. However, the first and last nodes are not connected.
- **Mesh**—In a mesh topology, each node is connected to one or more nodes. This configuration provides maximum redundancy to the network.
- **Ring**—In a ring topology, each node is connected to exactly two other nodes, forming a circular configuration. It requires at least three nodes to form a ring.

Supported Protection Schemes

Table 2: Feature History

Feature Name	Release Information	Feature Description
Protection Types Supported	Cisco ONP Release 4.1	<p>The following protection schemes are supported:</p> <ul style="list-style-type: none"> • 1+R: For each service, Cisco ONP automatically finds one working path. You can define the restoration path. • 1+1+R: For each service, Cisco ONP finds one working path, and one protected path. You can define the restoration path. • 1+1+R+R: For each service, Cisco ONP finds one working path and one protected path. You can define the restoration paths.

Cisco ONP supports the following protection schemes:

Figure 1: Protection Schemes

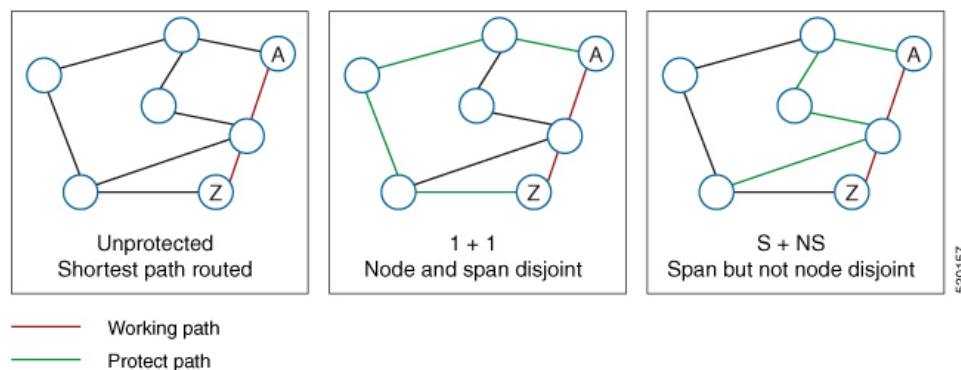

- **Unprotected**—In unprotected mode, the tool routes the service on the shortest path.
- **1+1**—Two client signals are transmitted to separate line cards or transponder cards instead of using Y-cable to split one client signal into two line cards or transponder cards. In client 1+1 protection, the failure and switchover are controlled by the client system. The following figure shows 1+1 protection.

Figure 2: 1+1 Protection

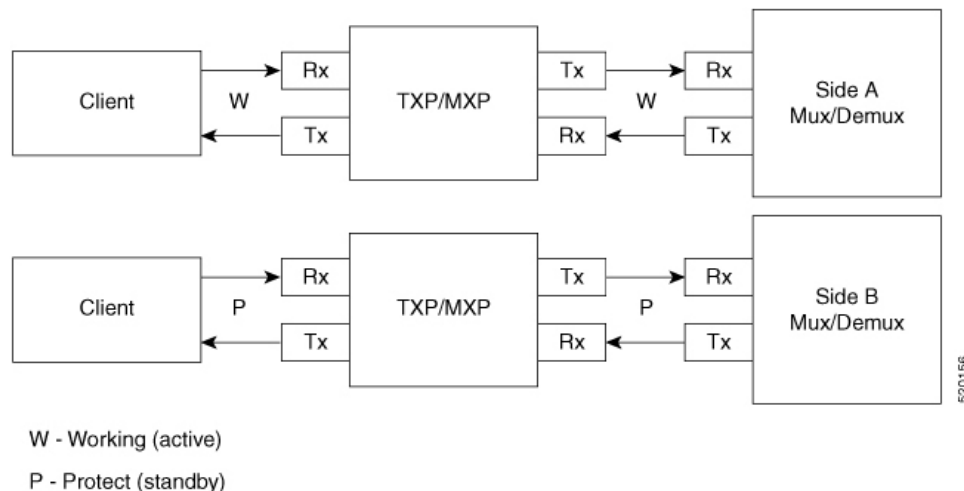

- **1+R**—Supported on SSON network. For each service, Cisco ONP automatically finds one working path. You can define the restoration path.
- **1+1+R**—Supported on SSON network. For each service, Cisco ONP finds one working path, and one protected path. You can define the restoration path.
- **1+1+R+R**—Supported on SSON network. For each service, Cisco ONP finds one working path and one protected path. You can define the restoration paths.
- **S+NS**—Supported on non-SSON network. Cisco ONP uses the shortest path for the working service, and the next shortest path for protection. The paths are span-disjointed but not node disjointed.
- **Unprotected Disjoint**—Supported on non-SSON network. Cisco ONP provides two cards following two completely disjoint paths in the network to reach their destination.

Supported Services

Cisco ONP supports the following OTN demands:

- ODU-1,ODU-2,ODU-3,ODU-4
- GE – Gigabit Ethernet
- 10GE – 10-Gigabit Ethernet
- 100GE –100-Gigabit Ethernet
- STS-3
- STS-12
- STS-48
- STS-192
- VC-4-4

- VC-4-16
- VC-4-64
- STM-64

Supported DWDM Channel Interfaces

See [Supported Cards and Pluggables, on page 139](#) and [Supported Aliens, on page 151](#) for the DWDM channel interfaces supported by Cisco ONP.

Supported Fiber Types

Cisco ONP supports the following fiber types:

- G652-SMF
- G652-SMF-28E
- TWR
- MC
- TWPlus
- TWMinus
- TWClassic
- FL
- LS
- TL
- G652-SMF
- ELEAF
- True Wave

Register New User

Use this task to register yourself as a user.

Procedure

- Step 1** In the browser URL field, enter the IP address or hostname of the Cisco ONP instance.
- Step 2** Click **Sign Up** in the Login page.
- Step 3** Enter the **Username**, **Email**, and **Password**, and click **Submit**.

Click **Generate** if you want a system-generated password. Copy and paste the system-generated password in the **Password** field.

Step 4 Click **Ok** in the **Success** dialog box.

Log in to Cisco ONP Web Interface

Use this task to log into the Cisco ONP web interface.

Procedure

Step 1 In the browser URL field, enter the IP address or hostname of the Cisco ONP instance.

If you are a new user, sign up. See [Register New User, on page 5](#), for more information.

Note If Google Chrome browser blocks your access to Cisco ONP due to self-signed certificate security, type **thisisunsafe** to proceed to the login page.

Step 2 Enter the username and password in the **Username** and **Password** text boxes.

Step 3 Click **Login**.

Cisco ONP Home Page

After your login, Cisco ONP displays its home page. The home page comprises the following elements:

- Menu bar—Includes various menus such as File, Network, Export, Import, Manage, Logs, Job Monitor, Control Panel, and Help. See [Menu Bar, on page 127](#).
- Last Login—Shows the last date and time when the user logged in to the Cisco ONP tool.
- Last Login IP—Shows the IP address of the client through which the user logged into the Cisco ONP tool previously.
- User name—Shows the name of the user, who has currently logged in to the Cisco ONP tool, for example: ADMIN.
- Reports tabs—Shows various reports under each tab. Report availability depends on whether a network is analyzed or not. Reports are also available in site properties after analyzing the network.
- Network tree—Displays the network name, and network elements, such as Sites, Fibers, Waves or Media Channels, SRLGs, and Subnet. See [Network Tree, on page 133](#).

Change Password

The procedure to change your existing password is:

Before you begin

[Log in to Cisco ONP Web Interface](#), on page 6.

Procedure

- Step 1** Click the login icon in the top-right corner of the home page.
 - Step 2** Click **Change Password** to change the existing password.
 - Step 3** In the **Change Password** dialog box, enter the **Old Password**, **New Password**, **Repeat New Password**.
 - Step 4** Click **Update**.
-

Reset Your Password

The following procedure shows how to reset the password.

Procedure

- Step 1** In the browser URL field, enter the IP address or hostname of the Cisco ONP instance.
 - Step 2** Click **Forgot Password ?** in the Cisco ONP login page. The **Forgot Password** page appears.
 - Step 3** Enter the registered email ID in the **Forgot Password** page.
 - Step 4** Click **Continue**.
A verification code is generated and sent to the registered email ID.
 - Step 5** Enter the verification code, new password and confirm password.
 - Step 6** Click **Continue**.
-

Sign Out from Cisco ONP

The procedure to sign out of Cisco ONP is:

Procedure

- Step 1** Click the login icon in the top-right corner of the home page.
 - Step 2** Click **Sign Out** to log out of the Cisco ONP tool.
-

Cisco Secure Development Lifecycle Compliance

Table 3: Feature History

Feature Name	Release Information	Feature Description
CSDL Compliance Enhancements	Cisco ONP Release 4.1	<p>The following CSDL compliance enhancements are supported:</p> <ul style="list-style-type: none"> • Displays the last login IP address of the client. • Allows you to set a passphrase for encryption of credentials during the installation of LNI application and database.

The following Cisco Secure Development Lifecycle (CSDL) compliances are implemented:

- Check for the existence of new passphrases against a dictionary.
- Display of the last login date and time of the user in the user interface of the Cisco ONP tool.
- Display of the last login IP: The IP address of the client through which the user logged into the server, previously.
- Warning the users through pop-up messages about the impending passphrase expiration.
- Option to allow an admin user or any user with CONFIGURATION_MANAGEMENT permission to set the lifetime of a passphrase and the grace period to change the passphrase through the system configuration tab.
- Prompt for user to change the passphrase through the passphrase change dialog box, when the admin user logs in for the first time.
- Option to allow the user to set a passphrase with a minimum of eight characters and a maximum of 127 characters as the length.
- The passphrase must include at least one lowercase alphabet, one uppercase alphabet, one number, and one special character.
- Option to allow the user to set a passphrase or key for encryption of credentials during the installation of Live Network Import (LNI) application. If not specified Cisco ONP uses the default key.
- Option to allow the user to set a passphrase with a minimum of eight characters and a maximum of 64 characters as the length, during the installation of Cisco ONP and LNI database.
- LNI application provides the details of all the ports used. See [Ports Used in LNI, on page 30](#).
- Option to allow the user to generate a password using **Generate Password** option.
- Display of the strength of the password set by the user.



CHAPTER 2

Manage Users and Roles

- [User Roles in Cisco ONP, on page 9](#)
- [Grant Access to a New User, on page 10](#)
- [Remove Access to a User, on page 11](#)
- [Delete a User, on page 11](#)
- [Create a New User Group, on page 12](#)
- [Assign a User to a User Group, on page 12](#)
- [Set Password Expiration for Individual User, on page 13](#)
- [Set Password Expiration for All Users, on page 14](#)
- [Lock and Unlock an Individual User Account, on page 14](#)
- [Expire the Password Set by an Individual User, on page 15](#)
- [Create a New Role, on page 15](#)
- [Assign a Role to a User Group, on page 16](#)
- [Manage Password Through Dictionary, on page 16](#)
- [Retrieve System Logs , on page 17](#)

User Roles in Cisco ONP

Initially, the administrator performs access control management tasks, like activating users after user sign-up, creating user groups, roles, and assigning roles and users to user groups. The admin or user with admin access grants access to the newly created user by activating the user. After the admin grants access, the new user will be notified by email (sent to the email address registered while signing up). It is only then that the new user is able to log in. By default, the following user roles are available in Cisco ONP.

1. **Admin:** The Admin user can create new user groups and assign user to user groups. Users are categorized into groups. There are certain predefined user groups in Cisco ONP. You cannot edit or delete these user groups. Admin can assign a group with a particular role. The role describes the actions that a particular user group can perform.
2. **Designer:** The Designer user can design a network. There are two ways to design a network.
 - Manual Design
 - Import Design

The designer user can create a network topology of any type (linear, ring, mesh) with Traffic, OLA, ROADM, and Passthrough sites, and assign the fibers with suitable spans between those sites. The designer

can only design the network and cannot analyze the network. The designer can view the reports, when any user shares the analyzed network.

3. **Planner:** The Planner user can design and analyze a network. After the Sites, Fiber spans, and Service demands are created, analyze the network to determine the network performance. Cisco ONP automatically optimizes the design and summarizes the optical transmission performance. In the analyzed state, all reports are available and updated. In the analyzed state, no aspect of the network design can be changed.
4. **Reader:** The Reader user can view users, user groups, roles, and permission. The Reader can also view the network topology, layout, connections, and BOM. By default, a user is assigned in the READ_ONLY_GROUP with a READER_ROLE.

You can also create new roles. See [Create a New Role, on page 15](#).

Under **Control Panel > Roles** and **Control Panel > Permissions**, you can view the permissions applicable for each role and the actions that can be performed for each permission.

Grant Access to a New User

All users with Admin role receive an email notification about new user registration.

Before you begin

[Log in to Cisco ONP Web Interface, on page 6](#) as a user with Admin role.

Procedure

Step 1 Click **Control Panel**.

The **Access Control Management** page appears.

Step 2 You can change the state of a user from INACTIVE to ACTIVE by using either of two ways:

- a. From the **State** field, click **INACTIVE** in the respective user row.
- b. Select the user row and click **Update**.
 - In the **Update User** dialog box, select the **Group** and **State** from the respective drop-down lists.
 - Click **Save**.

Step 3 Click **OK** in the **Success** dialog box.

- Note**
- After the Admin grants access, the new user gets notified by email (sent to the email address registered while signing up). It is only then that the new user will be able to log in.
 - The admin assigns a newly created user with a Role and Group that determines what actions the user can perform.
-

Remove Access to a User

Use this task to remove Cisco ONP access to a user.

Before you begin

[Log in to Cisco ONP Web Interface, on page 6](#) as a user with Admin role.

Procedure

- Step 1** Click **Control panel**.
The **Access Control Management** page appears.
- Step 2** You can change the state of a user from **ACTIVE** to **INACTIVE** by using either of two ways:
- a. From the **State** field, click **ACTIVE** in the respective user row.
 - b. Select the user row and click **Update**.
 - In the **Update User** dialog box, select the **Group** and **State** from the respective drop-down lists.
 - Click **Save**.
- Step 3** Click **OK** in the **Success** dialog box.
-

Delete a User

Use this task to delete a user.

Before you begin

[Log in to Cisco ONP Web Interface, on page 6](#) as a user with Admin role.

Procedure

- Step 1** Click **Control panel**.
The **Access Control Management** page appears.
- Step 2** Select the user to be deleted under the **USERS** tab and click **Delete**.
- Step 3** Click **Yes** in the **Warning** dialog box.
The message *User deleted successfully* appears. You can delete another user only after this message appears.
-

Create a New User Group

Use this task to create a new user group.

Before you begin

[Log in to Cisco ONP Web Interface, on page 6](#) as a user with Admin role.

Procedure

- Step 1** Click **Control Panel**.
The **Access Control Management** page appears.
- Step 2** Click the **USER GROUPS** tab.
- Step 3** Click **Create**.
- Step 4** In the **Create Group** dialog box, enter the **Group Name**.
- Step 5** Choose the appropriate role from the **Role** drop-down list. The available default roles are:
- ADMIN
 - PLANNER
 - DESIGNER
 - READER
- The **Role** drop-down list may also have user-defined roles that are listed under it.
- Step 6** Click **Save** to save the created user group.
- Step 7** Click **OK** in the **Success** dialog box.
-

Assign a User to a User Group

Use this task to assign a user to a user group.

Before you begin

[Log in to Cisco ONP Web Interface, on page 6](#) as a user with Admin role.

Procedure

- Step 1** Click **Control panel**.
The **Access Control Management** page appears.
- Step 2** Under the **USERS** tab, select the user who is to be assigned to the new group.

Step 3 Click **Update**.

Step 4 In the **Update User** dialog box, perform the following:

- Select the appropriate group from the **Group** drop-down list.
- Select **Active** or **Inactive** from the **State** drop-down list, to activate or inactivate the user in the group, respectively.
- Click **Save**.

Step 5 Click **OK** in the **Success** dialog box.

- Note**
- a. A user can belong to only one group.
 - b. Only one role can be assigned to any group.
 - c. All the users of a group have the same role as that of the group.
 - d. By default, a new user is assigned to the Read_Only_Group.

Set Password Expiration for Individual User

Use this task to set the expiration of the password set by the user.

Before you begin

[Log in to Cisco ONP Web Interface, on page 6](#) with Admin or Configuration_Management permission.

Procedure

Step 1 Click **Control Panel**.

The **Access Control Management** page appears.

Step 2 Select the user under the **USERS** tab.

Step 3 Click **Update**.

Step 4 In the **Update User** dialog box, click the **PASSWORD EXPIRY** tab.

Step 5 Enter values for the **Lifetime**, **Warning** and **Grace** fields.

Step 6 Click **Save**.

Note The password expiry settings like lifetime, warning and grace time, take effect after the existing password is changed by the user.

Step 7 Click **OK** in the **Success** dialog box.

Set Password Expiration for All Users

Use this task to set the expiration of the password for all users.

Before you begin

[Log in to Cisco ONP Web Interface, on page 6](#) with Admin or Configuration_Management permission.

Procedure

Step 1 Click **Control Panel**.

The **Access Control Management** page appears.

Step 2 Click the **System Configuration** tab.

Step 3 Enter values for the **Lifetime**, **Warning** and **Grace** fields.

Step 4 Click **Update**.

Note The password expiry settings like lifetime, warning and grace time, take effect after the existing password is changed by the user.

Lock and Unlock an Individual User Account

Use this task to lock or unlock an individual user account.

Before you begin

[Log in to Cisco ONP Web Interface, on page 6](#) as a user with Admin role.

Procedure

Step 1 Click **Control Panel**.

The **Access Control Management** page appears.

Step 2 Click the **USERS** tab.

Step 3 Select the user whose account you want to lock or unlock.

Step 4 Click **Lock** to lock the user account, or click **Unlock** to unlock the locked user account.

Note The user of a locked account must contact the admin to unlock the user account.

Expire the Password Set by an Individual User

Use the following task to expire the password set by an individual user.

Before you begin

[Log in to Cisco ONP Web Interface, on page 6](#) as a user with Admin role.

Procedure

- Step 1** Click **Control Panel**.
The **Access Control Management** page appears.
 - Step 2** Click the **USERS** tab.
 - Step 3** Select the user whose password you want to expire.
 - Step 4** Click **Expire**.
-

Create a New Role

Use the following task to create a new role.

Before you begin

[Log in to Cisco ONP Web Interface, on page 6](#) as a user with Admin role.

Procedure

- Step 1** Click **Control Panel**.
The **Access Control Management** page appears.
 - Step 2** Click the **ROLES** tab.
 - Step 3** Click **Create**.
 - Step 4** In the **Create Role** dialog box, enter the **Role Name** and select the **Permissions** for the role.
Note You can select more than one permission.
 - Step 5** Click **Save**.
 - Step 6** Click **OK** in the **Success** dialog box.
-

Assign a Role to a User Group

Use the following task to assign a new role to a user group.

Before you begin

[Log in to Cisco ONP Web Interface, on page 6](#) as a user with Admin role.

Procedure

- Step 1** Click **Control Panel**.
The **Access Control Management** page appears.
- Step 2** Click the **USER GROUPS** tab.
- Step 3** Select the user group whose role is to be updated.
- Step 4** Click **Update**.
- Step 5** In the **Update Group** dialog box, select the desired role from the **Role** drop-down list, and click **Save**.
- Step 6** Click **OK** in the **Success** dialog box.
-

Manage Password Through Dictionary

If a password exists in the predefined list of passwords under the **Content** column, the dictionary rejects the new password set by the user. You must have Admin or Configuration_Management permission to view and modify the dictionary.

By default, the **Rejection Mode** toggle button is disabled. Enable the **Rejection Mode** toggle button to verify the password against dictionary. This password verification check against the dictionary happens during any one of the following events:

- New user sign-up
- Password change
- Password reset using forgot password option

The following is the procedure to verify, whether the new password set by the user exists in the list of predefined passwords:

Before you begin

[Log in to Cisco ONP Web Interface, on page 6](#) as a user with Admin role.

Procedure

- Step 1** Click **Control Panel**.

The **Access Control Management** page appears.

- Step 2** Click the **DICTIONARY** tab.
- Step 3** Enter the password in the **Enter Passphrase** text box.
- Step 4** (Optional) Enter the limit (maximum number of matching passphrases) in the **Enter Limit** text box.
- Step 5** Click **Search**.

The matching passphrases get displayed.

Note If you have entered the limit, a number of search results matching the limit gets displayed. Otherwise, all matching passphrases get displayed.

Retrieve System Logs

The System Logs page shows at logs the events that are initiated during a specific time interval. See [Logs](#), on page 130.

Before you begin

[Log in to Cisco ONP Web Interface, on page 6](#) as an admin or a user with User Management and Network Management permission.

Procedure

- Step 1** Click **Logs**.
- Step 2** Click **Select Start Date**, and choose the start date. Similarly, click **Select End Date**, and choose the end date.
- Step 3** Click **FILTER** to retrieve the logs.

The following icons are available in the **System Logs** page:

Icons	Description
Export as CSV	Exports the system logs to an Excel sheet
Export Archive	Exports the system logs as a zip file
Import Archive	Imports the zip file
Refresh	Refreshes the system logs page
Clear Logs	Deletes the existing logs



CHAPTER 3

Design and Analyze Networks

- [Design a Network Using Cisco ONP, on page 19](#)
- [Create Optical Subnet for Non-SSON Networks, on page 34](#)
- [Create Optical Subnet for SSON Networks, on page 35](#)
- [Convert Non-SSON Network to SSON Network, on page 36](#)
- [Share a Network, on page 37](#)
- [Analyze the Network, on page 39](#)
- [Upgrade the Analyzed Network, on page 40](#)
- [Upgrade LNI Network, on page 42](#)
- [Upgrade the Software Release of a Network , on page 46](#)
- [Plan Mode, on page 48](#)
- [Import Alien, on page 53](#)
- [Download Alien, on page 54](#)
- [Delete Alien, on page 54](#)
- [Layout Template , on page 55](#)
- [Layout Visualization, on page 59](#)
- [Regenerate BoM Automatically, on page 63](#)
- [Add new Pluggables, Alarm Cables and 100G Client Bandwidth Licenses to BoM, on page 63](#)
- [Export IPC Report, on page 64](#)
- [Design Networks with SVO Card, on page 64](#)
- [Associate OLA or DGE Sites with SVO Cards, on page 65](#)
- [Upload NETCONF XML Files on SVO Web Interface, on page 66](#)
- [Export NETCONF XML Files for Individual Sites, on page 66](#)

Design a Network Using Cisco ONP

You can design a network in one of the following ways:

- **Manual Design**—Create a network design using a design palette.
- **Import Design**—Import a network design from an Excel sheet, Live Network Import or from an existing network from CTP, or another instance of Cisco ONP.

Manually Design a Network Using Cisco ONP

Table 4: Feature History

Feature Name	Release Information	Feature Description
Multi-Layer Platform (MLP) Greenfield Design with NCS 4k-1k-2k	Cisco ONP Release 4.1	<p>This feature allows you to perform the following:</p> <ul style="list-style-type: none"> • Supports NCS 4K-1K-2K multi-platforms • Visualizes new layout for Txp and SVO for NCS 2000 node • Supports different OTN service types with protection • Edits layout for NCS 4000 and NCS 1004 nodes

You can create any of the following network designs:

- Spectrum Switched Optical Network (SSON) that uses flexible spectrum allocation, where the required minimum spectral resources are allocated adaptively based on traffic demand and network conditions
- Non-SSON network that allocates single spectrum (fixed spectrum) irrespective of the traffic demand and network conditions

Perform the following steps to create a network in the Cisco ONP:

Before you begin

[Log in to Cisco ONP Web Interface, on page 6.](#)

Procedure

-
- Step 1** Choose **File > New**.
- The **Create New Network** dialog box appears.
- Step 2** If you want to create an SSON network, check the **SSON Network** check box, else leave the **SSON Network** check box unchecked.
- Step 3** Choose the **System Release** for NCS 2K from the drop-down list.
- You cannot change the system releases that are available for NCS 4K and NCS 1K.
- Step 4** Click **Create**.
- You can view a map and the design palette. For more information, see [Design Palette, on page 134](#).
- Step 5** Click the **Drawing Tool** icon (pencil and ruler crossed).
- Step 6** Add sites to the map using the drawing tool.

- a) Zoom into the map to the desired level. Click any of the site icons (**ROADM**, **OLA** or **Traffic(4K-1K-2K)**), and drag it to the sites on the map. Drag or click the map where a site has to be placed, when the cursor changes to the site icon.

SRLG is not supported in the SSON networks

Note Cisco ONP automatically calculates the distance based on the x and y coordinates on the map. Before you create the design, zoom in the map to the maximum for an accurate distance, because the distance is used to calculate signal degradation.

- b) Click the **Fiber** icon and drag it to connect from one site to another site. Continue this for all sites.

Step 7 Create services between the sites.

Cisco ONP provides only OTN service.

- a) Click the **Drawing Tool** icon and select **OTN Service** (Green in color).
- b) Add the service between the existing Traffic sites on the map.

Step 8 Create media channels (for SSON), or waves (for non-SSON) between the sites.

- a) Click the **Drawing Tool** icon, and select **Media channel** (purple in color), or **Waves** (red in color).
- b) Add the media channel, or waves between the existing sites on the map.

In the left pane, you can view a network tree panel with a default network name. The network elements added are displayed in the tree panel.

Step 9 Choose **File > Save As**.

Step 10 Enter a network name in the **Give a Network Name** dialog box.

Step 11 Click **Save**.

Create Shared Risk Link Group

You can use the Shared Risk Link Group (SRLG) feature for routing protected services. You can create SRLGs through the Excel import file SRLG tab or through the Cisco ONP GUI using the following procedure:



Note SRLG is supported only for the non-SSON network including the traffic nodes.

Before you begin

[Log in to Cisco ONP Web Interface, on page 6.](#)

Procedure

- Step 1** Click the network tree panel in the left.
- Step 2** Expand **Fibers**.
- Step 3** Check the check box next to each fiber in the same SRLG.
- Step 4** After all fibers are checked, right-click, and select **Create SRLG**.

SRLG is created with a unique name. You can rename the SRLG.

Import Network Using Excel Sheet

Use this task to import a network into Cisco ONP, using an Excel sheet.



Note By default, the system release of the Excel imported network is 11.0.

Before you begin

[Log in to Cisco ONP Web Interface, on page 6.](#)

Procedure

Step 1 Choose **File > Download Import Template** to download the Excel sheet template.

The template has the following mandatory tabs, and the respective fields to be filled in the Excel sheet.

Tabs	Description
Network	Label (name of the network), Platform (NCS2000)
Sites	Site Label, Type, X coordinates, Y coordinates, Pre Equip Degree, Grooming Site, CLLI code, and Site Address
Spans	Span label, A (Source site name), Z (Destination site name), Kms (Distance), Loss, A_Edge, Z_Edge, AZ_Loss, ZA_Loss, AZ_Kms, and ZA_Kms.
Demands	Demand Label, A (Source), Z (Destination), Y (Tertiary Source), B (Tertiary Destination), Type of Demand, Quantity, and Protection. Note: Y and B can be used with Unprotected Disjoint Service.
Channels	Channel label, A, Z, Wavelength, Protection, and Type
SRLG	SRLG Label and Spans.

Step 2 Fill the network details in the template file or edit the current network file, and save the file.

Step 3 Choose **Import > Excel**.

Step 4 Browse, select the saved file, and click **Import**.

Cisco Transport Planner Network Import Support

You can import the networks that are created and analyzed from Cisco Transport Planner (CTP) to Cisco ONP, to avoid recreating the networks that are already created in CTP. The CTP network files are in .mpz format. You can, release upgrade, the imported networks.



-
- Note**
- Network must be in design-analyzed or upgrade-analyzed mode.
 - You cannot import networks which are earlier than Release 11.0.
-

Supported Hardware

- Aliens and transponders
See [Supported Aliens, on page 151](#), and [Supported Cards and Pluggables, on page 139](#).
- Contentionless point-to-point demands
- Flex network
- Gain Equalizer



-
- Note** The Gain Equalizer node changes as a ROADM node when you unlock the site after the release upgrade.
-
- ROADM-SMR-9 and SMR-20
 - All flex supported amplifiers, controller cards, and chassis types
-

Import MPZ Design File

Use this task to import .mpz file from CTP to Cisco ONP.



-
- Note** Importing of mpz networks with P-Ring and A2A demands is not supported. Hence, we recommend you to delete these demands in CTP, reanalyze the networks in CTP and import the mpz into Cisco ONP.
-

Before you begin

[Log in to Cisco ONP Web Interface, on page 6](#) as a user with network creation permission.

Import the required aliens and layout template using **Manage > Alien** and **Manage > Layout Template** options. For more information, refer [Manage Alien](#) and [Import Layout Template for NCS 2000 Network in to Cisco ONP Database](#).

Delete the parameters that are not supported by Cisco ONP from the .mpz file and then import the .mpz file to Cisco ONP.

Procedure

- Step 1** Choose **Import > MPZ**.
The **Import File (.mpz)** dialog box appears.
- Step 2** Browse to the .mpz file stored in your local system.
- Step 3** Click **Import**.
The .mpz file gets imported to Cisco ONP.
- Note** If you view a blank screen when you click waves in the network tree, refresh the browser.
- Step 4** Choose **Network > Upgrade** or **Network > Release Upgrade** to make any changes on the imported network.
- Note**
- You cannot go back to design mode on the imported mpz network.
 - The wave label of imported mpz network in Cisco ONP is the service name present in the CTP properties window.
-

Export the CPZ File

Cisco ONP stores the network design file as .cpz file in its database. You can export the design file into your local system.

- The .cpz file of a network in the design mode includes design file, layout template, and alien details.
- The .cpz file of a network in the analyze mode includes a design file, analyze file, ANS file, per side ANS file, BOM, error messages, trace files, layout template, mpz, and report.
- For the network in upgraded mode, you can export only the last child in the parent child hierarchy.
- You can export only one network at a time.

Before you begin

[Log in to Cisco ONP Web Interface, on page 6](#)

Procedure

- Step 1** Choose **File > Open**.
The **Select Network To Open** dialog box appears.
- Step 2** Click the network that you want to export, from the list of networks.
The network opens.
- Note** If you view a blank screen when you open a network, refresh the browser, or log in to Cisco ONP again.

- Step 3** Choose **Export > CPZ**.
The **Export .cpz file** dialog box appears.
- Step 4** Rename the file if required.
- Step 5** Click **Export**.
- Step 6** Save the file in your local system.
-

Import CPZ File

You can import the cpz network design files that are exported from another Cisco ONP instance.



Note You can import only the networks that are exported from the current release.

Before you begin

[Log in to Cisco ONP Web Interface, on page 6.](#)

Procedure

- Step 1** Choose **Import > CPZ**.
The **Import .cpz file** dialog box appears.
- Step 2** Click **Choose file**, and select a cpz network design file that you want to import into Cisco ONP, from your local system.
- Step 3** Click **Import**.
If the names of the alien and layout template files available in the Cisco ONP database and the imported network file are the same, you are prompted to confirm whether you want to overwrite the existing file.
- Note** The error message "**Network already exists in the system with another user. New network will be created**" is just an information. You do not need to perform any action. Cisco ONP automatically imports as a new network specific to the user. There is no impact on the already existing network.
- Step 4** Check the **Overwrite Network** check box, if you want to overwrite the existing file.
If you leave the check box unchecked, Cisco ONP saves the imported network as a new network.
- Step 5** Choose the alien files and layout template that you want to replace.
If you do not choose the alien or the layout template file, the files will not be imported.
- Step 6** Click **Confirm**.
The imported network is saved in the Cisco ONP database.
-

Live Network Import

Table 5: Feature History

Feature Name	Release Information	Feature Description
Live Network Import	Cisco ONP Release 4.1	This feature allows you to import a live deployed network having NCS 1004, NCS 2000, and NCS 4000 nodes into Cisco ONP, using the LNI (Live Network Import) import template. This feature also allows you to view network topology, BOM, and layout report.

The Live Network Import (LNI) feature allows you to perform a live import of network having NCS 1004, NCS 2000, and NCS 4000 nodes into Cisco ONP. You must have Network Management role to perform the LNI operation. After importing you can visualize the complete deployed network details in Cisco ONP. Map shows the network topology, and you can view the node, fiber, OTN service, and media channel properties in the Network Tree, and the Entity Editor.

Perform Live Network Import

Use this task to perform live import of a network:

Before you begin

- Perform LNI only when the network is in a stable or running state. Do not perform LNI during the maintenance period for software upgrade.
- Configure all the mandatory parameters on the circuit.
- Make sure that the following Cisco IOS XR Software Maintenance Updates (SMUs) are loaded on the NCS 4000 devices on top of Cisco IOS XR Release 6.5.28:
 - ncs4k-6.5.28.CSCvu93045.tar
 - ncs4k-sysadmin-6.5.28.CSCvt67465.tar
 - ncs4k-6.5.28.CSCvv79518.tar
- Make sure that there is a provision for opening three TL1 sessions per NCS 2000 device for Live data collection. NCS 2000 devices should not be overloaded with too many TL1 sessions.
- Make sure that the fibers are configured with the same channel numbers (Spectral Density, ex: 91.0/82.0) on both source and destination ends.
- Check the card label set for the following NCS 2000 cards and update it if they are not aligned.

PID	Card Label
NCS2K-16-AD-CCOFS	AD-16-FS
NCS2K-20-SMRFS	SMR20-FS-CV

PID	Card Label
NCS2K-20-SMRFS-L	SMR20-FS
NCS2K-9-SMR17FS	SMR9-17-FS
NCS2K-9-SMR24FS	SMR9-24-FS
NCS2K-9-SMR34FS	SMR9-34-FS
NCS2K-9-SMR34FS-L	SMR9-34-FS
15454-M-RAMAN-COP=	OPT-RAMP-COP
15454-M-RAMAN-CTP=	OPT-RAMP-CTP
NCS2K-OPT-EDFA-35	OPT-EDFA-35

- You must install Microsoft Excel in the Client Machine from where the browser is launched to open Cisco ONP application.
- [Log in to Cisco ONP Web Interface, on page 6](#)

Procedure

Step 1 Choose **Export > Download LNI Import Template**, and download the template which is in the form of an Excel sheet.

Step 2 Fill the template with the details of all the nodes belonging to the network to be imported and save the file.

The following fields are mandatory:

- Node IP
- User Name
- Password
- Connectivity Type—TL1 for NCS 2000 nodes and NETCONF for NCS 1004 and NCS 4000 nodes
- Connectivity port—830 for NCS 4000 and NCS 2000 nodes

Note Enter a value in the range of 60–180 in the Connectivity Timeout field or leave the field empty.

Step 3 Choose **Import > Live Import**.

Step 4 Browse and choose the saved file.

Step 5 If you want to clean the existing LNI database of the nodes and perform a fresh import, check the **Fresh Import (Cleanup LNI Database)** check box.

Note We recommend fresh import of the live network.

Leave this check box unchecked, if you want to import the details of only few of the nodes which had issues during the previous import.

Note LNI import is not user-specific. When you perform a fresh import, Cisco ONP overwrites all the LNI data that are imported by the other users.

Step 6 Click **Import**.

Step 7 In the **Device Onboarding** dialog box, click **OK**.

Note If you try to import a network of unsupported version, the device collection does not happen, and an error message "device collection failed" appears. See [Supported Hardware and Software for LNI, on page 31](#).

Step 8 Click **Job Monitor**, and click **Check Progress** for the IMPORT_LIVE_NETWORK task, to view the status of the LNI operation in the **LNI Progress** dialog box. Click **Refresh** to see the updated status.

After LNI is completed, the job is removed from the **Job Monitor** page.

Step 9 Click **Logs** to view the list of events that are related to the LNI operation, as logs.

Step 10 After the completion of the LNI operation, choose **File > Open**.

The format of the LNI imported network filename is LNI_<Date>_<Time>.

Step 11 Click the imported network name to view the network under the **Map** tab and its corresponding network tree in the left panel.

The aggregated node including NCS 1004, NCS 2000, and NCS 4000 is indicated in purple color, and the aggregated node including NCS1004 and NCS 2000 is indicated in orange color in the network tree. You can view the tag **Imported from Network** in the top-right corner.

- Note**
- Even If some errors occur during the LNI operation, the LNI operation is not canceled. In such case, when you open the imported network, a warning message is displayed.
 - You can view the errors under the **Elements > Messages** tab.
 - Device collection failure is listed under critical messages.
 - The reason for failure is listed under noncritical messages.
 - If both NCS and Non-NCS PIDS are present in the inventory, Cisco ONP enables the **Enable NCS** option. You can edit this option during upgrade after unlocking the site, if necessary.
 - Service path for the restored circuits is displayed as follows in the Cisco ONP UI:
 - Primary Path: Working path before restoration
 - Secondary path: Protected path
 - Restoration path: Current work path after restoration

Note If the circuit is not in the restored state, the restoration path is not shown.

- SSON circuits carrying protected OTN services are merged as Client 1+1 protected Media Channel. Due to this, you may see difference in total number of SSON circuits between the imported network in Cisco ONP and the actual network.
- If LNI is not installed properly, you may encounter the errors such as LNI failure or LNI not able to purge the data. In such cases, we recommend starting and stopping the LNI services in the server where Cisco ONP and LNI are installed using the following commands:
 - Stop the LNI services.

```
root:~/$ONP_HOME# cd LNI
root:~/$ONP_HOME/LNI# bash ciscolniinstaller.sh -o stop -t update -m
offlinemode
```
 - Start the LNI services.

```
root:~/$ONP_HOME/LNI# bash ciscolniinstaller.sh -o start -t update -m
offlinemode
```

Note Wait for a minimum of five minutes after starting the services, for the LNI services to resume before triggering a new live network import. You can

Step 12 Click the **BOM** tab to view the BOM details of the network.

Note The PIDs of prototype cards are shown as "NA" in the BOM details of the LNI network.

You can export the CPZ, import the CPZ, and share the imported network. You can check the properties of the network using the **Entity Editor**.

Ports Used in LNI

LNI application uses the following ports. If any port is shut down due to any failure, then the service is restarted by the Docker system.

Port	Service	Usage
8761	Eureka Service	Registration and discovery service, which holds the information about all microservice applications
8088	API Gateway	Receives all the incoming requests, and then delegates the requests to internal microservices like LNI Broker
8086	Collector Service	Collects metrics and operation data from the devices
8082	Device Manager	Responsible for device onboarding process
8083	Inventory Service	Provides inventory data
9975	TL1 plug-in Service	South bound interface plug-ins for TL1 protocol-based NCS 2000 devices
8898	NCS 2K Inventory Adapter Service	Adapter module to transform NCS 2000 device response from collector to Cisco ONP NCMS schema-based POJO
8899	NCS 4K Inventory Adapter Service	Adapter module to transform NCS 4000 device response from collector to Cisco ONP NCMS schema-based POJO
8900	NCS 1K Inventory Adapter Service	Adapter module to transform NCS 1004 device response from collector to Cisco ONP NCMS schema-based POJO
9976	NETCONF plug-in Service	South bound interface plug-ins for NETCONF based 1K/4K devices
8102	LNI Broker Service	Provides interfaces for Cisco ONP BE service to trigger live network import
8085	Topology Service	Provides network topology data
8090	Circuit Service	Provides network circuit data
8024	NETCONF Adapter Service	Common adapter for Topology and Circuit services
8091	Model Aggregator Service	Aggregates inventory, topology, and circuit details under NCMS schema-based networks
8092	TL1 Adapter Service	Common adapter for Topology and Circuit Service
5601	Kibana	Data visualization and exploration tool that is used for log and time-series analytics, application monitoring, and operational intelligence use cases Note The default Edge browser on Windows OS is not supported for viewing the Kibana logs. Cisco recommends using Firefox or Chrome browser for viewing the Kibana logs.

Port	Service	Usage
2181	Zookeeper	Keeps track of status of the Kafka cluster nodes, and also keeps track of Kafka topics, partitions publish-subscribe messaging system that enables inter service communication
9092	Kafka	Publish-subscribe messaging system that enables inter-service communication
27017	Mongo	Database to persist services data

Supported Hardware and Software for LNI

The following table describes the software versions and hardware requirements of the network imported through LNI.

Table 6:

Property	Values
Network	
Network Type	SSON
Platform	ETSI
System Release	NCS 2000: R11.1, and R11.1.1.2 NCS 1004: XR 7.0.1 NCS 4000: XR 6.5.2.8
Site/Node	
Site Type	4K-1K-2K: ADD/DROP, 1K-2K;Regen, 2K:ROADM/OLA
ROADM	SMR-20, SMR-9-17FS, SMR-9-34FS, SMR-9-24FS
Amplifier	RAMAN-CTP, RAMAN-COP, EDFA35-24, EDFA35-35
Degree Mesh Type	DEG-5/UPG-4
Chassis Type	4K: NCS4016, 2K:NCS2006, 1K:NCS1004
Power Supply	4K-DC, 1K-DC, 2K-DC40
ECU	ECU-S
Controller Card	TNCS-2, TNCS-20
Channel Rule	82
Line Cards	NCS1K4-1.2T-K9=, NCS4K-4H-OPW-QC2

Property	Values
Evolved Mesh	ON and OFF
Node Protection	2K: Separated shelves, 4K: Single shelf
Mpo16Lc	MPO-16LC Unit
Mpo16ToMpo08	MPO16TO2MPO8Cable
Cascaded SMR	Yes
Enable NCS	Yes
Use Payg	No
Connection Verification	Yes, No
MF Unit	MF-6RU, MF6-10RU, or MF-1RU
Structure	Line, Multidegree
Scalable upto degree	4, 8, 12
Power redundancy	Yes
IP Address	IPv4
Fiber	
OSC Frame Type	Auto
DCN Extension	Yes
ENE/GNE	Yes
Length	Yes
Loss	Yes
Measurement Unit	KM
Length based Loss	No
Raman Amplified	Yes
Fiber Type	G652-SMF-28E
Connector Loss A	Yes
Connector Loss B	Yes
Cross OSC and Parallel OSC	Yes
Media Channel	
Traffic Type	NCS1004_SP_16QAM_16QAM_300G_27%SDFEC_60GBd

Property	Values
Protection	Unprotected, and 1+R
Path	Actual Path
Regen	Regen site
Multicarrier	No
Contentionless	Yes
Circuit State	Restored, Unrestored
Service	
Service Type	100GE, 10GE, STM-64
Protection	1+1, Unprotected, 1+R, 1+1+R, 1+1+R+R
Path	Actual Path
Client Type (1K)	OTU4
Interface Type (1K)	BH
Trunk Mode (1K)	200G, 300G
Baud Rate (1K)	60 and 69 GBd
Client Pluggable	ONS-QSFP28-LR4=, QSFP-100G-SR4-S=,ONS-QSFP-4X10-MLR=

Limitations of LNI

The LNI feature has the following limitations:

- You cannot perform multiple LNI at the same time.
- Scheduled LNI is not supported.
- LNI does not support the following:
 - Non-SSON Network import
 - Non-Contentionless configuration import
 - Circuit import with NCS 2000 Transponder or Muxponder cards
- Chassis position in layout may not be accurate in the live imported network.

Workaround: NCS 2000, NCS 1004, and NCS 4000 chassis are placed in separate racks for a better view of the layout. You can edit the same after network upgrade and analysis.
- If X, Y coordinates are not configured in the devices, nodes are overlapped in the Cisco ONP map.

Workaround: Configure X, Y coordinates before importing the network for a better view of the topology in Cisco ONP map; otherwise, you can drag and drop the nodes in the Cisco ONP map and adjust the node position after importing.

- Scalable up to degree parameter is not imported from the real device. Cisco ONP chooses the maximum scalable up to degree based on the number of line sides and contentionless sides present on the node.

Workaround: You can unlock node after upgrading and change the scalable up to degree. After unlocking the site, use layout template to rearrange the layout.

- Cisco ONP imports the proto-PID, if any, present in inventory, and show as N/A PID in the Cisco ONP BOM.
- Duplicate media channel label is not supported. If there are multiple media channels with same label present in the network, only one media channel is imported and the rest of them are discarded.
- Fiber name, source, and destination names may not match between the first and the second import. Source and destination site names may interchange for bidirectional fibers.
- If the regenerated demand is in restored state, the restored path is shown as working or protected path, and the service protection is shown as 1+R in Cisco ONP. The restoration details will not be available.
- Service protection type is shown as 1+1+R or 1+1+R+R only if restoration path is available. Otherwise, service protection type will be shown as 1+1.
- Preprovisioned cards are not listed in the Cisco ONP BOM, and they are populated after successful upgrade and analysis of the LNI network. Make sure that the cards are equipped to retrieve the PID details.
- Fibers may not be associated with correct optical subnet if the fibers are not configured with the same channel number at both source and destination ends. Due to this amplifier output power may not be within valid range. Hence, you either correct channel number at both source and destination nodes and re-import the network, or associate the fiber with correct optical subnet after network upgrade in Cisco ONP.

Create Optical Subnet for Non-SSON Networks

An optical subnet is a collection of spans with certain associated properties. When you create a new network, Cisco ONP automatically creates an optical subnet that is associated to the network. At least one optical subnet must exist for each network.



Note Check the **Current Subnet** check box in the properties window, to make the subnet you created as the current subnet. You cannot uncheck the **Current Subnet** check box.

The following procedure creates an optical subnet for Non-SSON networks:

Before you begin

[Log in to Cisco ONP Web Interface, on page 6.](#)

Procedure

- Step 1** Click **Subnet** in the network tree panel.
- Step 2** Right-click **Optical Subnet**.
- Step 3** Click **Create Optical Subnet**.
- The **Create Optical Subnet** dialog box appears.
- Step 4** From the **Cband Rules** drop-down list, choose the C-band design rules for the new optical subnet that you want to create.
- Step 5** Click **Save**.
- A new optical subnet with the design properties you selected is created and placed in the network tree panel under **OpticalSubnet**.

Note You can select new Cband rules from the **Cband Rules** drop-down list in the properties window.

Note You can add a fiber to a subnet from the **Fiber links** drop-down list in the properties window. You can also add a fiber to a subnet from the network tree panel. To add a fiber to a particular subnet in the network tree panel, perform the following steps:

- Right-click the required optical subnet and select **Edit Fibers**.
An **Info** dialog box appears displaying "*Do you want to continue?*".
- Click **OK**.
The UI freezes. You can only select a fiber from the map.
- Select the required fiber and click the **Done** button appearing near the zoom icon.
The fiber now appears in the **Fiber links** field. When you select the optical subnet, its corresponding fiber is highlighted in the map.

When a fiber is added to one of the subnets, it will be automatically removed from the other subnets. Only one subnet rule will be associated with one fiber.

Create Optical Subnet for SSON Networks

The following procedure creates an optical subnet for SSON networks:

Before you begin

[Log in to Cisco ONP Web Interface, on page 6.](#)

Procedure

- Step 1** Click **Subnet** in the network tree panel.

Step 2 Right-click **Optical Subnet**.

Step 3 Click **Create Optical Subnet**.

The **Create Optical Subnet** dialog box appears.

Step 4 From the **Spectral Density** drop-down list, choose the spectral density for the new optical subnet that you want to create.

The **Maximum Number of Channels** the you seen in the **Create Optical Subnet** dialog box, are set based on the spectral density that you have selected.

Step 5 Click **Save**.

A new optical subnet with the design properties you selected is created and placed in the network tree panel under **OpticalSubnet**.

Note You can select a new spectral density from the **Spectral Density** drop-down list in the properties window.

Note You can add a fiber to a subnet from the **Fiber links** drop-down list in the properties window.

You can also add a fiber to a subnet from the network tree panel. To add a fiber to a particular subnet in the network tree panel, perform the following steps:

- Right-click the required optical subnet and select **Edit Fibers**.

An **Info** dialog box appears displaying "*Do you want to continue?*".

- Click **OK**.

The UI freezes. You can only select a fiber from the map.

- Select the required fiber and click the **Done** button appearing near the zoom icon.

The fiber now appears in the **Fiber links** field. When you select the optical subnet, its corresponding fiber is highlighted in the map.

When a fiber is added to one of the subnets, it will be automatically removed from the other subnets. Only one subnet rule will be associated with one fiber.

Convert Non-SSON Network to SSON Network

The following procedure converts non-SSON networks to SSON networks:

Before you begin

[Log in to Cisco ONP Web Interface, on page 6.](#)

Procedure

Step 1 Choose **File > Open**.

The **Select Network To Open** dialog box appears.

- Step 2** Click a non-SSON network that you want to convert to SSON.
The network opens. Ensure that the network is in **Design Mode**.
- Step 3** Choose **Network > SSON Convert**.
- Step 4** Click **Ok**.
The error message, "Network cannot be converted to SSON due to following errors : [Network contains waves with invalid traffic types: [100G-SD-FEC, 200G-SD-FEC]]" appears.
- Step 5** Choose **Network > Entity Editor > Services**.
- Step 6** Expand **Waves** and navigate to trail, and click a trail.
- Step 7** Choose any NCS 1004alien from the **Src Card Type** drop-down list.
- Step 8** Click **Update**.
- Step 9** Choose **File > Save**.
- Step 10** Choose **Network > SSON Convert**.
- Select SSON alien from the **Traffic Type** drop-down list in the properties window.
 - You cannot convert a non-SSON network with Traffic Sites to SSON.
 - To convert a non-SSON network to SSON network in **Analyze** mode, upgrade or release upgrade the analyzed network. In the **Upgrade** mode, or **Release Upgrade** mode network, unlock all the channels, and force NCS 1004 alien.
-

Share a Network

Use these steps to share a network with one or more users or user groups:

Before you begin

[Log in to Cisco ONP Web Interface, on page 6.](#)

Procedure

- Step 1** Choose **File > Open**.
The **Select Network To Open** dialog box appears.
- Step 2** Select a network from the list of networks.
The map of the selected network opens.
- Step 3** Choose **File > Share**.
- Step 4** Select one or more users or user groups from the **Share Network** dialog box.
- Step 5** Click **Share**.

You can share the network with selected users or user groups in read-only mode.

Access a Shared Network

Use these steps to access a network shared by another user:

Before you begin

[Log in to Cisco ONP Web Interface, on page 6.](#)

Procedure

Step 1 Choose **File > Open Shared Network**.

The **Select Network To Open** dialog box appears with a list of networks that are shared by other users.

Step 2 Click a network name from the list.

The shared network opens in read-only mode.

Step 3 Choose **File > Save As**.

Step 4 Enter the name in the **Give a network name** dialog box, and click **Save**.

A copy of the shared network is saved.

Note You can work on this copy of network, depending on the privileges of your user role. For example, if your user role is Designer, you can change the design of the saved copy of the shared network, but you cannot analyze the shared network.

Step 5 (Optional) Share the updated network with other users.

Unshare a Network

Use these steps to unshare a network with one or more users or user groups:

Before you begin

[Log in to Cisco ONP Web Interface, on page 6.](#)

Procedure

Step 1 Choose **File > Open**.

The **Select Network To Open** dialog box appears.

Step 2 Click a network from the list of networks.

The network opens.

- Step 3** Choose **File > Share**.
- Step 4** In the **Share Network** dialog box, remove the name of one or more users or user groups from the list.
- Step 5** Click **Share**.
- The shared network is no longer available to the users or user groups that are removed.
-

Analyze the Network

The Analyze tool allows you to analyze the network after design completion.

Before you begin

[Log in to Cisco ONP Web Interface, on page 6.](#)

Procedure

- Step 1** Choose **File > Open**.
- The **Select Network To Open** dialog box appears.
- Step 2** Click a network that you want to analyze, from the list of networks.
- The network opens.
- Step 3** Choose **Network > Analyze**.
- The Cisco ONP analysis progress indicator indicates the analysis status.
- If there is any failure in the analysis stage, a dialog box appears with the message, "Analysis Failed."
- Step 4** Choose the **Elements > Messages** tab to see the list of error details in the analyzed network..
- By default, it shows only the key messages when the **Critical Only** toggle button is enabled. If you want to view the entire network message, disable the **Critical Only** toggle button.
- Note**
- Step 5** If you find an error message under the **Messages** tab, resolve the error and analyze the network again. Repeat this step until all errors are resolved.
- Note** The error message "Unexpected Situation 999" may occur when the optical simulation becomes inconsistent due to incorrect values of properties entered or modified while designing the network. Call Cisco TAC to know the exact cause of the error and modify the suggested property value for the successful analysis of the network.
-

Bottom-Up Flow

Bottom-up support enables step-by-step creation of a network. Adding all the services and waves on day 0 itself is not mandatory to analyze the network and view reports. Bottom-up flow enables you to build a network over a period.

Day 0: Create a network with only the topology added. Add all sites and add fibers between them. Analyze the network and view the reports without adding any services or waves.

Day 1: Add waves between the sites that are added on Day 0 and newly added sites and fibers. Analyze the network and view the reports.

Day 2: Add services and tag waves that are created on Day 1 and newly added sites and fibers. Analyze the network and view the reports.



Note After you have created the topology with sites and fibers added, you can add either a service or a wave. You need not follow any specific order.

Bottom-up flow is applicable only for Non-SSON networks. In order to achieve this, you must set A2A mode as A2A_fast in network properties.

Idle Timeout in the Analyze Mode

If you keep the browser idle for more than 15 minutes, you are logged out of Cisco ONP. The default timeout is set to 15 minutes. The System Admin can disable this feature by changing the enabled option in the configuration file on the server to false. You can change the default time of 15 minutes by editing the duration option in the configuration file.

During a long network analyze cycle, you get logged out due to idle timeout, and the network analysis runs in the background. When you log back, the same network opens in one of the following states:

- If the analysis is still on, the analysis progress bar is shown, and you cannot perform any other action.
- If the analysis is complete, the network opens in the Analyze mode.
- If the analysis has failed, the network opens in the design mode, and you can view the reason for failure on the **Elements > Messages** page.

The session time out does not redirect you to the login page always; so, reload or enter the URL again.

Upgrade the Analyzed Network

Cisco ONP allows you to upgrade an existing network that is in analyzed mode. You can modify certain properties of a network element in the network while retaining the existing network layout and design in the locked state. Upgrade is supported for both SSON and non-SSON networks.

Use these steps to upgrade your network:

Before you begin

[Log in to Cisco ONP Web Interface, on page 6.](#)

Procedure

- Step 1** Choose **File > Open**.
- The **Select Network To Open** dialog box appears.
- Step 2** Click the analyzed network that you want to upgrade.
- The network opens.
- Step 3** Choose **Network > Upgrade**.
- Step 4** Click **Yes** in the **Warning** dialog box.
- The message “Network Upgraded Successfully” appears. The network goes into upgrade mode and network elements such as sites, fiber, waves (for non-SSON), and media channel (for SSON) are locked.
- Step 5** Right-click the network element that you plan to modify from the network tree panel, and click **Unlock**. You can unlock individual element and one at a time for multiple elements until the lower level in the network tree hierarchy.
- For example, you can hierarchically unlock at the node level, side level, side add/drop card level, and side amplifiers level.
- Step 6** You can make the following modifications according to your requirement:
- Edit the properties of network elements.
 - Delete the network elements from the network.
 - Add a new site, wave, services, demands, optical subnet, or fiber into the network map.
- The newly added elements are automatically displayed in the network tree panel, and by default, remain unlocked.
- Note** You can insert a node in the upgrade mode only for the unlocked fiber. Therefore unlock the fibers that are connected to the node and add nodes to the network.
- Step 7** Choose **File > Save**.
- Step 8** Choose **Network > Analyze**.
- After the analysis is completed, the newly added elements are locked, and the optical reports and installation parameters of the upgraded network are updated.
- When you add services or fibers while upgrading a network that has where layout template is applied, the template gets updated with the newly added service or fiber. You can export this template, make changes and reapply it to another network.
- Step 9** Choose **Network > Design** to further upgrade the newly upgraded network design.
- When you upgrade a network every time, Cisco ONP saves the new version of the network as a child network, and maintains the parent and child relationship.
-

Upgrade LNI Network

Table 7: Feature History

Feature Name	Release Information	Feature Description
Upgrade LNI Network	Cisco ONP Release 4.1	This feature allows you to upgrade and modify the imported LNI (Live Network Import) network as required. You can also correct LNI errors, reanalyze the network, and view the updated parameters such as BOM, layout, connections, and optical results.

The Upgrade feature can be used to correct LNI errors, modify the network, reanalyze the network and view updated BOM, Layout, Connections, and Optical Results.

Use these steps to upgrade the LNI network:

Before you begin

[Log in to Cisco ONP Web Interface, on page 6.](#)

Procedure

Step 1 Choose **File > Open**.

The **Select Network To Open** dialog box appears.

Step 2 Click a network imported through LNI that you want to upgrade.

The network opens.

Step 3 Choose **Network > Upgrade**.

Step 4 Click **Yes**.

The message “Network Upgraded Successfully” appears. After upgrading the network, the network goes into upgrade mode, and network elements such as Sites, Fiber, OTN Services and Media Channels are locked.

You can modify certain properties of the network element, while retaining the existing network layout and design locked.

Step 5 Right-click the network element that you plan to modify from the network tree panel, and click **Unlock**. You can unlock individual element and multiple elements until the lower level in the network tree hierarchy.

For example, you can unlock node level, side level, side add/drop card level, and side amplifiers level.

Step 6 You can make the following modifications according to your requirement:

- Edit the properties of network elements.
- Delete the network elements from the network.
- Add a new site, wave, services, demands, optical subnet, or fiber into the network map.

The newly added elements are automatically displayed in the network tree panel, and by default, remain unlocked.

- Note**
- Unlocking media channel has few constraints. See [Media Channel Unlocking Scenarios, on page 44](#).
 - Cisco ONP automatically sets the scalable up to degree value based on certain design rules, as this value is not present in the network that is imported through LNI. Hence, we recommend you to check and update the actual scalable up to degree value, if necessary.

Step 7 Choose **File > Save**.

When you upgrade a network every time, Cisco ONP saves the new version of the network as a child network, and maintains the parent and child relationship.

Step 8 Choose **Network > Analyze**.

Note Analysis is successful only if a consistent and valid network is imported from LNI.

Step 9 If the analysis fails, go to **Elements > Messages** tab and check for the failure reason.

Step 10 If any validation error is thrown from any component, resolve the issue by manually changing the network or by reimporting the LNI networks after correcting some configuration on the live network. See [Possible Error Scenarios and the Workarounds, on page 44](#).

Step 11 Re-Analyze the network.

Step 12 Click **Layout** tab and edit the layout manually to adjust chassis or card position for NCS 4000 and NCS 1004 platforms. See

Step 13 Click the **BOM** tab, and the **Results** tab to view the BOM and optical results.

- Note**
- a. If the LNI inventory has any unconnected cards, that will be removed from the CONP reports after upgrading and analyzing the LNI network.
 - b. The following PIDs are added in the Cisco ONP BOM after upgrading and analyzing the LNI network. These PIDs are not part of the LNI network BOM.
 - Pre-provisioned PIDs
 - Release software PIDs
 - Optical cables—Cables used for Internal Patch-cord Connection (IPC) is not imported in LNI as this data cannot be retrieved from device
 - Attenuators
 - SMR port license PIDs—Only SMR card PID is imported as part of LNI. If licensed PID is retrieved, corresponding port licenses are added after upgrading and analyzing the LNI network, based on the number of ports used
 - USB cables—Added if pre-provisioned passive cards present
 - Blank cards—Blank cards are not imported. They are added in Cisco ONP after upgrading and analyzing the LNI network

Media Channel Unlocking Scenarios

The following table explains the various media channel conditions and the unlocking possibilities.

Table 8:

Conditions	Unlocking Possibilities
Channel has OTN services going over it. For 4K-2K, the service is directly mapped to the channel, and for 4K-1K-2K, the service is mapped via OTU4 trail.	Cisco ONP throws an error indicating that there are OTN services associated with the media channel. You can neither update nor delete the channel. To unlock and delete the media channel, unlock associated OTN services first and then unlock the media channel.
Channel does not have OTN services going over it. For example, in case of 4K-1K-2K, the media channel carries empty OTU4s.	Cisco ONP allows you to unlock the channel but does not automatically clear the properties of the channel or its child entities such as Trail and Section, irrespective of whether the properties are user-defined or auto-assigned. Also, the channel is not unlocked automatically, if it has any associated OTU4. After unlocking the channel, you can delete the channel, but cannot update the properties of the channel or its child entities. (When the properties of the media channel or its child entities are auto-assigned, only wavelength is cleared and set to Auto, and all other properties are not cleared.)
Channel has neither OTN services nor OTU4(s) going over it. In case of 4K-1K-2K networks, Media Channel does not carry even empty OTUs.	Cisco ONP allows you to unlock the channel and automatically clears auto-assigned properties. After unlocking you can perform the following: <ul style="list-style-type: none"> • Update various properties of the channel and its child entities. • Delete the channel.

Possible Error Scenarios and the Workarounds

Following table describes the workarounds for the errors that are shown under the **Elements > Messages** tab.

Table 9: Error Scenarios and the Workarounds

Error Message	Workarounds
Device Authentication failure	Check the username and password of the device, which is given in LNI input Excel and retry LNI import with valid device credentials.
Device collection failed or Device not reachable.	Check for any connectivity issue in the setup, fix it and retry LNI import.

Error Message	Workarounds
In Site4.A, output power setting is not supported by the amplifier.	Unlock C-Band amplifiers for side A inside Site4 in the Network tree and force the valid output power. If not sure, set it to Auto and analyze. Cisco ONP chooses the best value based on the configuration.
Cannot Route demand! Did not find any valid Omnidirectional Side.	For protected OTN service or SSON service, a minimum of two contentionless sides must be present on the source and destination sites. Check and add contentionless sides on the target service source and destination site and analyze.
<ul style="list-style-type: none"> • Demand OTU3 has unrecognized type [OTU3] • ServiceGroup does not support the demandType OTU3 for OTU3 	Only 100GE, 10GE, and STM-64 service rates are supported. If any other service rate is present in the network, unlock the specific service, change it to one of the supported service types and update the ODU time slot accordingly and analyze.
Primary OTN Demand [100GE_Flex] has invalid Timeslot ranges. Allowed ranges are [1-80]	100GE service type must have ODU time slot in the range of 1–80. If any other value is set, update the correct value or leave it blank so that Cisco ONP can set it to the correct value.
Cannot complete mesh connections at Site3.	Unlock the site and reanalyze.
No OTN demand found for NCS4K trunk port - NCS4016-B - OTU40/8/0/1.	No action required. This is an information message to the user.
Fiber between Node1.A and Node2.B has an invalid value in connector loss value	Unlock the corresponding fiber couple and update the correct connector loss value to be greater than zero. The typical value is 0.2.
Fiber between Nod1.C and Node2.C has an invalid value in Tot SOL Loss w/o Connectors.	Unlock the corresponding fiber couple and update the correct Tot SOL Loss w/o Connectors. The value should be greater than zero.
Span Fiber-2 is forced as Raman but no traffic is present.	Remove Raman forcing on the fiber, or check and force the path for any service so that it goes through Raman enabled span.
Couple Fiber-2 has Raman enabled on the duct but corresponding Raman Forcing is missing.	Force RAMAN-CTP or COP on the Fiber-2 connecting node interface or remove RAMAN forcing on the Fiber-2



Note No specific action is required for noncritical messages. These are just information messages to the user.

Upgrade the Software Release of a Network

Table 10: Feature History

Feature Name	Release Information	Feature Description
Release Upgrade	Cisco ONP Release 4.1	This feature allows you to choose the NCS 2000 system release to the desired release (11.1.0, 12.0.1, or 12.1.0), while performing the release upgrade of CTP network, Cisco ONP network, network imported through Excel, and LNI network.

You can upgrade the software version of a network that is imported from CTP, the network created in Cisco ONP, LNI Network, and Excel imported network to any desired release. Release upgrade is supported for both SSON and non-SSON networks having NCS 2000 nodes with ROADM, OLA, Traffic, or the Passthrough functionality.

Release upgrade is supported starting with NCS 2000 Release 11.1.0.



Note NCS 2000 supports SVO from the Release 12.1.0.

The following table lists the releases to which the existing system release can be upgraded, for each type of network..

Network	Upgrade Release
CTP network (.mpz)	<ul style="list-style-type: none"> • From 11.0.0 to 11.1.0, 12.0.1, and 12.1.0 • From 11.1.0 to 12.0.1, and 12.1.0
Cisco ONP network	<ul style="list-style-type: none"> • From 11.0.0 to 11.1.0, 12.0.1, and 12.1.0 • From 11.1.0 to 12.0.1, and 12.1.0 • From 12.0.1 to 12.1.0
Excel imported network	From 11.0.0 to 11.1.0, 12.0.1, and 12.1.0 From 11.0.0 to 11.1.0, 12.1.0, and 12.2.0

Network	Upgrade Release
LNI network	11.1.0 to 12.0.1 and 12.1.0 11.1.0 to 12.1.0 and 12.2.0 Note You cannot directly release upgrade an LNI network. Perform the following: <ul style="list-style-type: none"> • Upgrade the LNI network. see Upgrade LNI Network, on page 42) • Analyze the network. (see Analyze the Network, on page 39) • Release upgrade the analyzed LNI network.

Before you begin

[Log in to Cisco ONP Web Interface, on page 6.](#)

Procedure

-
- Step 1** Choose **File > Open**.
The **Select Network To Open** dialog box appears.
- Step 2** Click the network in which you want to perform system release upgrade.
The network opens.
- Step 3** Choose **Network > Release Upgrade**.
- Step 4** Choose the **System Release** of NCS 2000, to which you want to upgrade, from the drop-down list.
- Step 5** Click **Submit**.
The upgraded network is saved as a child network.
The network elements are locked in the network tree after the release upgrade. You can unlock and modify the elements.
- Note** If the PMD coefficient does not get updated with the expected value, update the fiber type first, followed by the PMD value when you edit the fiber properties.
-

Plan Mode

Table 11: Feature History

Feature Name	Release Information	Feature Description
What-if Analysis for OTN Services	Cisco ONP Release 4.1	This feature extends the current implementation of What-if analysis for the OTN Services that are connecting the aggregated nodes. The failure report includes the number of failed services, restored services, and unrestored services. This feature is supported for SSON (4K-1K-2K and 1K-2K) and non-SSON (4K-2K) networks.

Plan mode enables you to perform what-if analysis on the existing network resources, such as failing and restoring the fiber, OTN services, and site. This mode is applicable only for PLANNER and ADMIN roles. This mode simulates the actual network behavior during failure and determines whether a service can be rerouted; however, this mode does not suggest how to turn-up new wave lengths, insert new nodes, cards, or ports, and so on.

The network can enter the **Plan** mode only from the **Analyze** mode. The what-if analysis can be done on the NCS 2000 aggregated node (ROADM, OLA, Passthrough), Traffic node (1K-2K, 4K-2K and 4K-1K-2K), the node created in Cisco ONP, CTP imported (mpz), and LNI imported networks.

Enter the Plan Mode

The following procedure shows how to enter the Plan mode:

Before you begin

[Log in to Cisco ONP Web Interface, on page 6](#) as a user with admin or planner role.

Procedure

-
- Step 1** Open the network in Analyze mode.
 - Step 2** Choose **Network** > **Enter Plan Mode**.

Switching to Plan Mode progress bar appears. The message, *Entered Plan Mode successfully* appears in the **Success** dialog box.

Exit the Plan Mode

The following procedure shows how to exit the Plan mode:

Before you begin

Log in to [Cisco ONP Web Interface, on page 6](#) as a user with admin or planner role.

Procedure

-
- Step 1** Open the network in the Analyze mode.
Step 2 Choose **Network > Exit Plan Mode**.
-

Fail a Fiber

The following procedure shows how to fail a fiber or a list of fibers in the Plan mode:

Before you begin

Log in to [Cisco ONP Web Interface, on page 6](#).

Procedure

-
- Step 1** Expand the **Fibers** option in the network tree panel.
Step 2 Right-click the fiber, and click **Fail**. You can choose multiple fibers to fail by checking the check boxes next to the fibers.

All media channels or waves, OTN services, and demands that pass through the failed fiber fail. You can see the failed media channels from the Map option or from the network tree.

- Note**
- You can also fail a fiber or undo a fiber failure from Map.
 - You can view the unrestored channel details in the failure report and the reason for restoration failure under **Elements > Messages** tab.
 - Failed channels are indicated with a red cross symbol, impacted fibers are marked with yellow cross symbol, and the restored channels with a green tick symbol.
-

Undo Fiber Failure

The following procedure shows how to undo fiber failure in the Plan mode:

Before you begin

Log in to [Cisco ONP Web Interface, on page 6](#).

Procedure

- Step 1** In the network tree panel, click **Fiber**.
- Step 2** Right-click the failed fiber, and click **Undo Fail**.
-

Create a Failure Set

You can click any set of fibers or sites, right-click , and fail them. The failed fibers or sites are marked with a red cross mark beside them. You can also choose multiple fibers or sites.

- Cisco ONP saves the user created failure sets.
- You can save multiple failure sets under a given failure group.

The following procedure shows how to create a failure set:

Before you begin

[Log in to Cisco ONP Web Interface, on page 6.](#)

Procedure

- Step 1** Right-click the **Failure Groups** option in the network tree panel.
- Step 2** Click **Add Failure Group**.
- A Failure group gets created.
- Step 3** Choose the **Fibers or Sites** to fail by checking the check boxes next to the them.
- Step 4** Right-click the chosen **Fibers or Sites** and click **Fail**.
- Step 5** Select the network name, and right-click.
- Step 6** Click **Add Failure Set**.
- Step 7** Select the Failure Group to which the failed fibers or sites must be added.

The Failure Set gets created under the Failure Group. The failed fibers or sites are added to the created **Failure Set**.

Note If networks have dark fibers (which does not carry any traffic), that path is not considered for restoration.

Fail a Site

The following procedure shows how to fail a site or a list of sites in the Plan mode.

Before you begin

[Log in to Cisco ONP Web Interface, on page 6.](#)

Procedure

-
- Step 1** Expand the **Sites** option in the network tree panel.
- Step 2** Right-click the site, and click **Fail**. You can choose multiple sites to fail by checking the check boxes next to the sites.
- You can also fail a site from the network map view.
-

Undo Site Failure

The following procedure shows how to undo the site failure in the Plan mode:

Before you begin

[Log in to Cisco ONP Web Interface, on page 6.](#)

Procedure

-
- Step 1** In the network tree panel, click **Site**.
- Step 2** Right-click the failed site, and click **Undo Fail**.
- You can also undo the site failure from the network map view.
-

Failure Report

The failure report shows the following parameters:

Report	Description
Failed Fibers	Shows the failed fibers in the network.
Failed Sites	Shows the failed sites in the network.
Impacted Fibers	Shows the fibers that are impacted due to the site failure.
Total Channels	Shows the total number of media channels in the network.
Failed Channels	Shows the total number of media channels that are passing through the failed ducts or sites in the network.
Restored Channels	Shows the total number of media channels that are restored from the failure state.

Report	Description
Unrestored Channels	Shows the total number of media channels that are not restored from the failure state due to the unavailability of alternate paths.
Fiber HotZones	Shows the fibers that have utilized greater than or equal to 80% of the bandwidth. You can modify the threshold by updating the value in the Feature.Properties file. <ul style="list-style-type: none"> • Fiber: Shows the fibers that are listed under fiber hot zones. • Utilization Before (%): Shows the percentage of bandwidth that is utilized before the channel restoration. • Utilization After (%): Shows the percentage of bandwidth that is utilized after the channel restoration.
Total Services	Shows the total number of services going through the fiber that was failed.
Failed Services	Shows the number of failed services going through the fiber that was failed.
Restored Services	Shows the number of restored services going through the fiber that was restored.
Unrestored Services	Shows the number of unrestored services going through the fiber that was restored.

:

Export Failure Report

The following procedure shows how to export the failure report.

Before you begin

[Log in to Cisco ONP Web Interface, on page 6.](#)

Procedure

Choose **Export > Failure Report** to export the failure report as an Excel sheet.

You can save the Excel sheet.

Export Failure Report from Map

The following procedure shows how to export the failure report from the map:

Before you begin

[Log in to Cisco ONP Web Interface, on page 6.](#)

Procedure

- Step 1** Click **Failure Report** under **Map**.
- Step 2** Click **Export** to export the failure report as an Excel sheet. You can save the Excel sheet.
-

Restore Failed Channels

The following procedure shows how to restore the failed fibers:

Before you begin

[Log in to Cisco ONP Web Interface, on page 6.](#)

Procedure

- Step 1** Choose **Network > Enter Plan Mode**.
- Step 2** Click **Restore**.
- The message, "Restoration is in progress" appears.
- Step 3** Click **Failure Report** to view the number of media channels that are restored or unrestored.

Note Restored channels are indicated with a green color tick mark in the network tree and map.

All media channels or waves, and demands that pass through the restored fiber also get restored. The Path Computation Element (PCE) supports the restoration of the OTN services based on the optical feasibility and OTN constraints.

Import Alien

Alien Wavelength is a way to connect a DWDM interface from any external element to a third-party optical network.

Use this procedure to import an alien or aliens:

Before you begin

[Log in to Cisco ONP Web Interface, on page 6.](#)

Procedure

- Step 1** Choose **Manage > Aliens**.
- The **Manage Alien** dialog box appears. The default aliens available in the server are:

- Aliens_titano5_Sauron
- NCS1004_Aliens_V3

Interfaces under Aliens_titano5_Sauron are:

- T5_100G_25%_DE
- T5_200G_15%_DE
- T5_100G_25%
- T5_100G_15%_DE
- T5_200G_25%
- T5_100G_15%
- T5_200G_15%
- T5_200G_25%_DE

Step 2 Click **Add**.

The **Import Alien (.mxd)** dialog box appears.

Step 3 Click **Choose File** and browse to the .mxd file stored in your local system, and click **Import**.

After the alien is imported, a list of related interfaces appears.

Step 4 Choose the interfaces to import by checking the check box next to them. The selected interfaces get added to **Type** drop-down list in the properties window of the network tree.

When you create waves, you can use the interfaces in the **Type** drop-down list.

Download Alien

Use this procedure to download an alien or aliens:

Procedure

Step 1 Choose **Manage > Aliens**.

The **Manage Alien** dialog box appears.

Step 2 Choose an alien or multiple aliens to download.

Delete Alien

Use this procedure to delete an alien or aliens:

Before you begin

[Log in to Cisco ONP Web Interface, on page 6.](#)

Procedure

-
- Step 1** Choose **Manage > Aliens**.
The **Manage Alien** dialog box appears.
- Step 2** Choose an alien or multiple aliens to delete.
- Step 3** Click **Delete** to delete the selected aliens.
-

Layout Template

Layout templates are reusable templates that are used to design layout configurations for a network. When you have a network with fixed layout rules applicable for multiple nodes, you can use these templates to accurately set up the layout for those nodes. These templates save you time, effort, and they minimize errors.

Export Layout Template

Table 12: Feature History

Feature Name	Release Information	Feature Description
Layout Template Enhancement	Cisco ONP Release 4.1	This feature allows you to export the layout template for an individual site or for all the sites. The layout template export is possible only if the network is analyzed in Cisco ONP Release 4.1. The export of layout template is supported on 4K, 4K-1K-2K, and 2K nodes.

Use the following procedure to export the layout template of a specific site or all sites:

Before you begin

[Log in to Cisco ONP Web Interface, on page 6.](#)

Procedure

-
- Step 1** Choose **File > Open**.
The **Select Network To Open** dialog box appears.

- Step 2** Click the network whose network layout template you want to export.
The network opens.
- Step 3** Choose **Network > Analyze**.
- Note** Network must be successfully analyzed to proceed further.
- Step 4** Click the **Layout** tab.
- Step 5** Click the **Hierarchy** tab.
- Step 6** Click the name of a site for which you want to download the layout template.
- Step 7** Hover the mouse pointer over the **Export** icon and click **Layout Template** for **Current site** or **All Sites**.
The **Export Layout Template** dialog box appears.
- Step 8** Click **Export**.
- Note**
- You can export the layout template for node of the type 4000 and 1000, but the exported layout template will contain only the layout of NCS 2000 nodes. To export the layout template for the node type NCS4K-1K-2K and NCS1K-2K, perform the following:
 - Right click the site name under the **Hierarchy** tab, and click **Export**.
 - Click **OK** to export the layout template in text format.
 - The NCS 2000 layout template is in XML format.

Import Layout Template for NCS 2000 Network in to Cisco ONP Database

Use the following procedure to import a template into the Cisco ONP database:

Before you begin

[Log in to Cisco ONP Web Interface, on page 6.](#)

Procedure

- Step 1** Choose **Manage > Layout Templates**.
- Step 2** Click **Add** in the **Manage Layout Template** dialog box.
- Step 3** Click **Choose Files** and select a template from your local system.
- Step 4** Click **Import**.
The template is imported to the Cisco ONP database.

Download Layout Template for NCS 2000 Network

Use the following procedure to download a template from the Cisco ONP database:

Before you begin

[Log in to Cisco ONP Web Interface, on page 6.](#)

Procedure

- Step 1** Choose **Manage > Layout Templates**.
 - Step 2** In the **Manage Layout Template** dialog box, choose the template that you want to download.
You can also choose multiple templates.
 - Step 3** Click **Download**.
Save the template into your local system.
-

Delete Layout Template for NCS 2000 Network

Use the following procedure to delete a NCS 2000 Network template from the Cisco ONP database:

Before you begin

[Log in to Cisco ONP Web Interface, on page 6.](#)

Procedure

- Step 1** Choose **Manage > Layout Templates**.
 - Step 2** In the **Manage Layout Template** dialog box, choose the template that you want to download.
You can also choose multiple templates.
 - Step 3** Click **Delete** to delete the template from the Cisco ONP database.
-

Apply NCS 2000 Layout Template into a Site

Use this task to apply the NCS 2000 Layout template into a site. The site can be NCS4K-2K, NCS1K-2K-4K, or NCS1K-2K, but the template will be applied only to the NCS 2000 section of that site.

Before you begin

[Log in to Cisco ONP Web Interface, on page 6.](#)

Procedure

- Step 1** Choose **File > Open**.
The **Select Network To Open** dialog box appears.
- Step 2** Click the network where you want to apply the layout template into an NCS 2000 site.
The network opens.
- Step 3** Choose **Network > Entity Editor**.
- Step 4** In the **Entity Editor** window, expand **Sites** and choose the site.
- Step 5** In the right pane, choose the required template from the **Layout Template** drop-down list.
- Note** Make sure that the other properties under **Layout** section such as **Chassis Type**, **Power Supply**, **Controller Card**, **Node Protection**, **Redundant Controller Card**, and **MF-Unit** are set to *Auto*. Otherwise the **Layout Template** drop-down list remains disabled.
-

Import NCS 1000 and NCS 4000 Layout Template into NCS1K-2K and NCS4K-1K-2K Sites

Use this task to import NCS 1000 and NCS 4000 layout templates that were exported, into 4K-2K and NCS4K-1K-2K Sites.

Before you begin

[Log in to Cisco ONP Web Interface, on page 6.](#)

Procedure

- Step 1** Choose **File > Open**.
The **Select Network To Open** dialog box appears.
- Step 2** Click the network that has the site to which you want to apply the layout template.
The network opens.
- Step 3** Click the **Layout** tab.
- Step 4** Add the required NCS 4000 and/or NCS 1000 chassis, cards, and pluggables to the required slot of the added chassis. See [Edit the Layout Manually, on page 60](#)
- Step 5** Click the **Hierarchy** tab.
- Step 6** Click **Edit** to enter the edit mode.
- Step 7** Right click the name of a site on which you want to import the layout template, and click **Import**.
- Step 8** Choose the layout template that you want to import into the site and click **OK**

The layout template gets applied to the site.

Layout Visualization

Table 13: Feature History

Feature Name	Release Information	Feature Description
Layout Visualization and Edit	Cisco ONP Release 4.1	This feature allows you to view and adjust the position of NCS 4016 and NCS 1004 chassis and cards in the layout. This feature is supported only on 4K-1K-2K and 1K-2K aggregated nodes and not supported on stand-alone NCS 2000 node.

This feature allows you to visualize the layout of a network, designed using Cisco ONP. You can view the arrangement of racks, chassis inside the racks and cards inserted in the chassis. When you click a particular Rack or Chassis or Card in the **Hierarchy** panel, the corresponding Rack or Chassis or Card gets highlighted in the Layout image. You can zoom in and zoom out the Layout image.

View Network Layout

The procedure to view the network layout is as follows:

Before you begin

[Log in to Cisco ONP Web Interface, on page 6.](#)

Procedure

-
- Step 1** From the **File** menu, click **Open**.
The **Select Network To Open** dialog box appears.
- Step 2** Click the network to open from the list of available networks.
- Step 3** Choose **Network > Analyze**.
- Note** Network must be successfully analyzed to proceed further.
- Step 4** Click the **Layout** tab.
- Step 5** In the **Hierarchy** panel on the left side, click the site.
- Note** The OLA sites are highlighted in green color, ROADM sites in blue color and Aggregated nodes in purple color.
Passthrough sites are not listed under layout.

Step 6 Click any rack under a site to visualize the rack view of the network under **Layout** tab.

Step 7 Click any chassis under a rack to visualize the chassis view of the network.

Note When you click the Aggregated node under **Hierarchy** panel, NCS 1004, NCS 2000 and NCS 4000 series chassis are placed in separate racks.

You can click the screenshot icon to take screenshot of all racks layout of the selected site.

Edit the Layout Manually

The Manual layout edit feature is used to adjust the position of NCS 4016 and NCS 1004 chassis and cards in the layout.

The procedure to edit the layout manually is as follows:

Before you begin

[Log in to Cisco ONP Web Interface, on page 6.](#)

Procedure

Step 1 Choose **File > Open**.

The **Select Network To Open** dialog box appears.

Step 2 Click the network to open from the list of available networks.

Choose the network where 4K-1K-2K and 1K-2K aggregated nodes are added. This feature is not supported on NCS 2000 node.

Step 3 Choose **Network > Analyze**.

Note Network must be successfully analyzed to proceed further.

Step 4 Click the **Layout** tab.

Step 5 Click **Edit** to enter the Edit mode.

Step 6 Select the Chassis (4K-1K-2K and 1K-2K) or Card from a particular rack.

Step 7 Drag and drop the selected Chassis or Card from a particular rack to the empty slot in the same or different Chassis or Rack.

Step 8 Click **Done** to save the changes in the Layout.

View the Layout Details Using Tooltip

You can hover over the Racks or Chassis or cards in the Rack and view the details using Tooltip.

Copy the Configurations of a Particular Node to Another Node

The configuration can be copied from one node to another node only for the manual 4K-1K layout movement.

The procedure to copy the configurations of a particular node to another node of a different site is as follows:

Before you begin

[Log in to Cisco ONP Web Interface, on page 6.](#)

Procedure

Step 1 Choose **File > Open**.

The **Select Network To Open** dialog box appears.

Step 2 Click the network to open from the list of available networks.

Step 3 Choose **Network > Analyze**.

Note Network must be successfully analyzed to proceed further.

Step 4 Click the **Layout** tab.

Step 5 Select the Rack, Chassis, or Card of a particular site.

Step 6 Select the site to where you want to copy the configurations to, from the **Copy To** drop-down list.

Step 7 Click **New Rack** to add a new rack. The configuration gets copied to the new rack.

Step 8 Click **Done** to save the changes in the Layout.

Note You can also cut, copy, and delete Racks, Chassis, and Cards in the Chassis from the Layout.

Export Port Usage of LNI Network

Table 14: Feature History

Feature Name	Release Information	Feature Description
Multi-Layer Connections Phase 1	Cisco ONP Release 4.1	<p>This feature provides the connection trace of a service across various interfaces in a network. This feature allows you to export the following:</p> <ul style="list-style-type: none"> • Consolidated port usage report based on network in addition to the internal port details which you can view by hovering the mouse pointer over the tooltip • Port usage report based on sites • Port usage report only for LNI imported networks

Use the following procedure to export the port usage details of an LNI network:

Before you begin

[Log in to Cisco ONP Web Interface, on page 6.](#)

Procedure

-
- Step 1** Choose **File > Open**.
The **Select Network To Open** dialog box appears.
- Step 2** Click the LNI network whose port usage you want to export.
The network opens.
- Step 3** Choose **Network > Analyze**.
Note Network must be successfully analyzed to proceed further.
- Step 4** Click the **Layout** tab.
- Step 5** Click the **Hierarchy** tab.
- Step 6** Click the name of a site for which you want to download the port usage.
- Step 7** Mouse hover the **Export** icon and click **Port Usage** for **Current site** or **All Sites**.
The **Export Port** dialog box appears.

Step 8 Click **Continue**.

The port usage details are exported in the Excel sheet format.

Note

- If you modify any services in the NCS 4000 node after upgrading the LNI network , the changes will not get updated in the port usage details.
- The demand labels seen against the trunk ports of NCS4K-DWDM line card in the port mapping report are not logically related to the NCS 4000 trunk ports, but are related to NCS 1004 client ports.

Regenerate BoM Automatically

You can view the new Chassis or Card added to the existing layout under the **BOM** tab. You can also view the regenerated BoM after manual editing of the layout.

Add new Pluggables, Alarm Cables and 100G Client Bandwidth Licenses to BoM

You can add new pluggables, alarm cables and 100G bandwidth licenses of NCS 1004 and NCS 4000 platforms to the existing BoM.

The procedure to add new pluggables, alarm cables and 100G client bandwidth licenses to the existing BoM is as follows.

Before you begin

[Log in to Cisco ONP Web Interface, on page 6.](#)

Procedure

Step 1 Choose **File > Open**.

The **Select Network To Open** dialog box appears.

Step 2 Click the network to open from the list of available networks.**Step 3** Choose **Network > Analyze**.

Note Network must be successfully analyzed to proceed further.

Step 4 Click the **BOM** tab.**Step 5** Click **Add**.

The **New** window opens.

Step 6 Enter the Cisco part number of the pluggable or alarm cable or 100G bandwidth license in the **Cisco Part Number** field.

Step 7 Choose the **Quantity** of pluggables or alarm cables or 100G bandwidth licenses to be added.

Step 8 Click **Add**.

The new pluggables or alarm cables or 100G bandwidth licenses are added to the BoM list.

Export IPC Report

You can export the connections of a current site or all sites to an Excel sheet using the following procedure:

Before you begin

[Log in to Cisco ONP Web Interface, on page 6](#)

Procedure

Step 1 From the **File** menu, click **Open**.

The **Select Network To Open** dialog box appears.

Step 2 Click the network to open from the list of available networks.

Step 3 Choose **Network > Analyze**.

Note Network must be successfully analyzed to proceed further.

Step 4 Click the **Layout** tab.

Step 5 z

Step 6 Click the **IPC** tab.

You can view the patches that are listed in the left pane. Click each patch to view the details such as position, card, and port of the source and destination sites.

Step 7 Hover over the **Export** icon, and click **Current site** or **All Sites** option.

The **Export IPC** dialog box appears.

Step 8 Click **Continue** to export the connections of the current site or all sites.

Design Networks with SVO Card

An SVO card along with the application software provides functionality-based licenses for alarm correlation, performance monitoring, connection verification, and Optical Time Domain Reflectometry (OTDR). You can design a network with ROADM and TRAFFIC nodes that are equipped with SVO cards.

Features

- The SVO card is a two-slot card.

- The SVO card acts as the primary card for all the networks after Release 12.1.0.
- To achieve high availability, you can have two SVO cards equipped in one node.
- You can use two 10G SFP+ pluggables to connect two SVO cards present in a node.
- You cannot have two SVO cards in the same chassis, to achieve high availability in the network.
- When designing the network, you can connect a Cisco ASR 920 Switch to the SVO cards.
- The SVO can be used as a card or as a UCS-based solution.

SVO Licenses

SVO cards require either Base License or SVO Full License (High Availability, Connection Verification, Flex Spectrum). If you do not select SVO Full License, by default, SVO Base License and High Availability are enabled.

The different types of SVO licenses are

- Cisco NMS: This includes features such as High Availability, Connection Verification, Flex spectrum, and OTDR.
- Third-Party NMS: This includes features such as NBI (North Bound Interface), Alarm Correlation, Performance Monitoring, and Circuit Provisioning.

Chassis Licensing

- Every chassis added to the network must have license after Release 12.1.0. For the release upgraded network, a new chassis license is added after it is analyzed in Cisco ONP Release 4.0 or higher.
- There are many variants of the chassis license, such as 1-chassis, 5-chassis, 10-chassis, 20-chassis, 50-chassis, and so on. The variants of chassis license are added based on cost optimization.
- A license is required for every chassis that is added to the network after the first chassis.
- Chassis License Flush Out: You can flush out the existing chassis license and purchase a new chassis license. If you hold the existing chassis license, the license remains active even if the site is unlocked.
- Chassis License Flush Out is supported only in the network upgrade mode.
- You can use the existing license with new changes in chassis, if you do not use the Chassis License Flush Out option.

Associate OLA or DGE Sites with SVO Cards

The following procedure shows how to associate OLA sites with the SVO cards:

Before you begin

[Log in to Cisco ONP Web Interface, on page 6.](#)

Procedure

- Step 1** In the network tree panel, right-click any ROADM site.
- Step 2** Click **Edit SVO Associations**.
- Step 3** Select the OLA sites on the map to toggle the SVO connections. Click **Done** at the top-right corner to confirm the selection.

You can open widgets in the map and select top section to view the association.

Note You can also right-click any ROADM site from the Map and click **Edit SVO Associations**. For the sites that are of DGE type, the **Edit SVO Associations** option is not displayed.

The tool associates the OLA and DGE sites that are not associated by you, with the SVO card during the network analysis.

Upload NETCONF XML Files on SVO Web Interface

The following procedure shows how to upload the NETCONF XML files on the SVO web interface:

Procedure

- Step 1** In the browser URL field, enter the IP address of the SVO line card.
The login page appears.
- Step 2** Enter the username and password.
- Step 3** Click **Login**.
- Step 4** Click the hamburger icon at the top-left of the page, and select **Node Configuration**.
- Step 5** Click the **Node Setup** tab.
- Step 6** Click **Select files**.
- Step 7** Browse to the NETCONF XML files exported from the Cisco ONP GUI and upload them.

If the passive unit ID in the NETCONF file exceeds the range 1–126, SVO displays an error message. Validate the XML file and reimport.

Note If the value of FEC mode already provisioned in the 200G-CK-C line card does not match with the value available in the NETCONF XML file, SVO displays an error message. We recommend that you remove the provisioned FEC settings for this card and reimport the XML file.

Export NETCONF XML Files for Individual Sites

The following procedure shows how to export NETCONF XML files for individual sites from the Cisco ONP GUI.

Before you begin

[Log in to Cisco ONP Web Interface, on page 6.](#)

The network must be in Analyze mode.

Procedure

Step 1 In the network tree panel, enable the **Stage** button.

Step 2 Check the individual site check box.

You can select only one site at a time and download the NETCONF XML file for that site by enabling the **Stage** button.

Step 3 Right-click the site.

Step 4 Click **Generate NetConf XML**.

The message, "Success. Netconf exported successfully" appears.



CHAPTER 4

Modify Network Properties

- [Modify Network Properties](#), on page 69
- [Modify Site Properties](#), on page 72
- [Modify Fiber Properties](#), on page 82
- [Modify Fiber Couple Properties](#), on page 86
- [Modify Service Properties](#), on page 87
- [Services Aggregation](#), on page 90
- [Modify Wave Properties](#), on page 94
- [Modify Media Channel Properties](#), on page 94
- [Modify Trail Properties](#), on page 96
- [Modify Section Properties](#), on page 98
- [Modify Side Properties](#), on page 99
- [Modify C-Band Amplifier Properties](#), on page 100
- [Sort the Network Elements](#), on page 105
- [Regeneration Support](#), on page 105
- [Multidegree ROADM](#), on page 106

Modify Network Properties

Use this task to modify the properties of the network.

Before you begin

[Log in to Cisco ONP Web Interface](#), on page 6.

Procedure

- Step 1** In the network tree, click the network name.
You can view the basic properties of the network at the bottom of the network tree.
- Step 2** Modify the following network properties as required.

Property	Description
Name	Modify the network name as required.

Property	Description
Quick Analysis	<p>Check the Quick Analysis check box to quickly analyze the network by using a less accurate algorithm.</p> <p>The quick analysis option does not optimize the DCU and amplifier placement algorithm, hence resulting in an approximate BoM.</p> <p>To receive an accurate BoM, uncheck the Quick Analysis check box.</p>
DWDM Interfaces	<p>Cisco ONP supports 100G and 200G transceivers as DWDM interfaces.</p> <p>This option is applicable only for automatically created waves, when OTN services are present.</p> <ul style="list-style-type: none"> • 100G—The entire network chooses the 100G wavelength for transmission. • 200G—The entire network chooses the 200G wavelength for transmission. <p>If you enable both 100G and 200G options, by default, the entire network chooses the 200G wavelength for transmission. If 200G wavelength is not optically feasible, then it selects 100G automatically for transmission.</p>
Customer Name	Enter the customer name.
Platform	Choose ANSI (North American standard) or ETSI (European Telecommunications Standards Institute) from the drop-down list. ANSI networks do not allow you to define SDH (ETSI) service demands. ETSI networks do not allow you to define SONET (ANSI) service demands.
Measurement Unit	Displays the unit of measurement of span length. By default, it is kilometer (km), and you cannot edit it.
A2A Mode	<p>Choose the A2A (Any to Any) mode. The available options are:</p> <ul style="list-style-type: none"> • A2A_None • A2A_FAST
A2A Power Output	The power output value is based on the chosen A2A mode.
A2A Demand Type	The demand type is based on the chosen A2A mode.
A2A Channel TypeContentionless	<p>Choose the type of channel. You can choose multiple types. The available options are:</p> <ul style="list-style-type: none"> • Contentionless—This property enables an N-degree ROADM node to accommodate N wavelengths of the same frequency from a single add or drop device. • Colorless—The colorless property enables tuning of channel wavelengths without changing the optical interface of the port. • Colored—The Colored property dedicates a separate port for each wavelength.
SSON	Indicates whether the network is an SSON network.

Property	Description
Use client Payg	Check this check box to enable the Pay As You Grow feature on the client cards. The PAYG feature enables you to implement a cost-effective solution when the wavelength requirements are comparatively less than the maximum capacity of the network. A standard card is configured to work on maximum supported wavelengths, whereas a PAYG license comprises license restricted cards and a base license. So, instead of purchasing a standard card, you can purchase a PAYG license.
System Release	
NCS 4K	Displays the system release of the NCS 4000 node in the network.
NCS 2K	Displays the system release of the NCS 2000 node in the network.
NCS 1K (Available only on the SSON network)	Displays the system release of the NCS 1004 node in the network.
Previous NCS 2K (Available only on the Release upgraded network)	Displays the system release of the NCS 2000 node in the network, before the Release upgrade.
Naming Convention Enabled	(Display only.) By default, the Naming Convention Enabled option is enabled by default for the networks that are created in Cisco ONP, and you cannot edit it. By default, the sides are named from T, S, R, Q, P, O, N, M, L, K, J, I, H, G, F, E, and index, depending upon the used Scalable Upto parameter. <ul style="list-style-type: none"> • You can import a mpz network without naming convention enabled, but the Cascaded SMR option remains disabled. • You cannot edit the label name of the side.
SVO	Choose the type of network management solution. The available options are: <ul style="list-style-type: none"> • SVO—Chooses SVO card • UCS—Chooses SVO application that is hosted on a server. • Auto—Chooses SVO card as default, for SVO solution.

- Step 3** Click **Update**.
- Step 4** To modify the advanced properties of the service, click **Show Advanced Properties** or choose **Network > Entity Editor**.
- Step 5** In the **Entity Editor** window, click the **Site** tab.
- Step 6** Click the network, and modify the properties in the right pane.
- Step 7** Click **Update**.

Modify Site Properties

Use this task to modify the properties of the site.

Before you begin

[Log in to Cisco ONP Web Interface, on page 6.](#)

Procedure

- Step 1** In the network tree, expand **Sites**, and click a site.
You can view the basic properties of the site at the bottom of the network tree.
- Step 2** Modify the following site properties as required.

Property	Description
General	
Name	Enter the site name, either alphanumeric or numeric.
Type	Choose the type of site. For example, ROADM, OLA, Pass-through, or a Traffic site. <ul style="list-style-type: none"> You can add a passthrough site as a place holder. You cannot add services or waves to this site and therefore cannot generate the report. Later, you can convert the passthrough site to a ROADM, OLA, or the Traffic site in the design mode. OLA is an optical line amplifier site that is used only for amplification. You cannot add service or waves on this site. You cannot add a Traffic site of the type 4K-2K into an SSON network. If you add a Traffic site into a network, you cannot upgrade the network.
Node Type	The default value is FLEX NG-DWDM for all nodes. This field is non-editable.
Equipment Configuration	Choose the configuration from the drop-down list. This option is available only for the Traffic site. The available options are: <ul style="list-style-type: none"> Large CO - NCS 4016 Small Site - NCS 4016 Small Site - NCS 4009

Property	Description
Traffic Type (only for Traffic site)	<p>Choose the traffic type. The available options are:</p> <ul style="list-style-type: none"> • 4K_1K_2K (for SSON) • 1K_2K (for SSON) • 4K_2K (non- SSON)
SSON	Indicates whether the network is an SSON network.
Layout	
Chassis Type	<p>Choose the type of chassis. Chassis type is supported for all the sites except passthrough.</p> <p>The available options are:</p> <ul style="list-style-type: none"> • M2 Chassis • M6 Chassis • M15 Chassis • Auto <p>M15 is the default option when you choose Auto.</p> <p>Note M2 Chassis is not supported for networks that are designed in release 12.0.1.</p>
Power Supply	<p>Choose the type of Power Supply. The available options are Auto, AC Power, and DC Power.</p> <p>The default option is DC Power.</p>
C Band	
Structure	Displays the structure of the site: Multi degree for ROADM and Traffic sites, and Line for OLA and Passthrough sites. This field is non-editable.
Functionality	<p>Displays the site functionality. This field is non-editable. Following is the functionality available for each type of sites:</p> <ul style="list-style-type: none"> • Optical Cross Connect (OXC) for ROADM and traffic site • Auto for OLA site, Cisco ONP downgrades OLA site to passthrough if OLA is not required. • Passthrough for passthrough site
Scalable up to Degree	<p>This parameter determines the maximum number of degrees, ducts, or line sides that can be supported by the site. The available options are 2, 4, 8, 12, and 16. The default option is 4. The network is scalable up to 16 degrees for ROADM and Traffic sites. Choose 2 to have a LINE ROADM site.</p> <p>For OLA and passthrough, the value is 2 and is noneditable.</p>

Property	Description
Site Type	<p>Choose the type of site.</p> <p>The available options are:</p> <ul style="list-style-type: none"> • Auto • SMR-20 • SMR-9 <p>The Site type is Line for the OLA site.</p>

Step 3 Click **Update**.

Step 4 To modify advanced properties of the site, click **Show Advanced Properties**, or choose **Network > Entity Editor**.

Step 5 In the **Entity Editor** window, expand **Sites** under the network tree, choose the site, and modify the following properties that are displayed in the right pane. For more information on entity editor, see [Entity Editor, on page 136](#).

Properties	Description
General	
CLLI Code	Enter a string holding the CLLI code.
Site Address	Enter the site address.
Evolved Mesh	By default, this option is unchecked. When you enable this feature on the network, it is automatically enabled on the associated sites of the network.
Status	Displays the status of the network. It shows whether the network is Up or Down .
Weight Lbs	Displays the weight of all the units of the site, in pounds.
Node Protection	<p>Choose the Node Protection. The available options are:</p> <ul style="list-style-type: none"> • Same shelf • Separated shelves
Mpo16Lc	<p>Displays the fan-out module. The default option is MF-MPO-16LC.</p> <p>The MPO-16 to 16-LC fan-out module is a double slot module with one MPO-16 connector (COM) and eight LC duplex connectors. The MPO-16 connector is compatible with the SMR20 FS EXP and 16-AD-CCO FS units.</p>

Properties	Description
Mpo16ToMpo8	Choose the required Mpo16 to Mpo8 converter. The available options are: <ul style="list-style-type: none"> • MPO16ToMPO8Cable • MF-2MPO_ADP
Cascaded SMR	Enable this option to add Layer-2 contentionless sides.
Flex Spectrum	By default, this check-box remains checked for newly created network. You cannot edit it.
Grooming Site	When you enable this option, it indicates that OTN traffic can be groomed at this site.
MR-MXP BreakOut Cable	Check this check box to use the ONS-MPO-MPOLC-10 breakout cable to interconnect the client ports of the MR-MXP card with the NCS2K-MF-MPO-20LC passive module.
8X10G-FO	Check this check box to use the NCS2K-MF-8X10G-FO passive module only for 10G on the client-side of the NCS2K-400G-XP card. By default, this passive module is enabled.
Bill of Material	
Enable NCS	This feature enables NCS features on all sites in the network.
Use PAYG	The Pay As You Grow (PAYG) functionality significantly reduces the initial setup cost and enables the purchase of another wavelength capacity on a need basis. PAYG enables port-based cost or licensing for SMR-9 and SMR-20 cards.
Connection Verification	Enable this check box to: <ul style="list-style-type: none"> • Validate the correct optical interconnection between the optical cards inside a Flex ROADM. • Measure the insertion loss of the external passive path. • Validate the quality of the connections to the patch panel. • Check if the insertion loss is within expected value. The following cards support connection verification: <ul style="list-style-type: none"> • SMR20 FS CV • MF-DEG-5-CV • MF-MPO-16LC-CV • MF-UPG-4-CV

Properties	Description
Layout	
Chassis Type	<p>Choose the type of chassis. The available options are:</p> <ul style="list-style-type: none"> • M2, M6, and M15 Chassis for OLA • M6 Chassis for ROADM and Traffic • M15 Chassis for ROADM and Traffic • Auto for all nodes <p>Note Chassis type is not supported for the passthrough site.</p>
Power Supply	<p>Choose the type of Power Supply. The available options are based on the chassis type:</p> <ul style="list-style-type: none"> • Auto for all type of chassis • AC Power, DC power for M15 and M2 chassis • AC Power, DC Power, AC2 Power, DC40 Power, and DC20 Power for M6 chassis
Controller Card	<p>Choose the type of the controller card.</p> <p>For NCS 2000 site, the default controller card is TNCS-2. The available options are based on the chassis type chosen. By default, controller cards that are supported by M15 chassis are listed. The available options are:</p> <ul style="list-style-type: none"> • Auto • TNC/TSC, TNC-E/TSC-E, TNCS, TNCS-0, TNCS-2, and TNCS-20 for M2 chassis • TNC/TSC, TNC-E/TSC-E, TNCS, TNCS-0, TNCS-2, and TNCS-20 for M6 chassis • TNCS, TNCS-0 TNCS-2, TNCS-20 for M15 chassis
Redundant Controller Card	Choose whether to use a redundant controller card.

Properties	Description
Layout Template	<p>Choose the required layout template.</p> <p>Note After the chosen layout template is applied, all layout properties will be reset and disabled.</p> <p>Note After design analysis, if the applied layout template is not considered for card placement in the layout, check for the error message (noncritical) under the Elements > Messages tab. If you see a template-related error which indicates that there is a mismatch between the cards that are defined in template and the cards that are created on the site, perform the following:</p> <ul style="list-style-type: none"> • Export the template from the Layout page, and modify it as required. • Import the modified template using the Manage > Layout Template option. • Switch to Design mode and apply the template to the site using the Entity Editor. • Reanalyze the network to get the correct layout populated.
UTS AC Power Cables	<p>Choose the type of cables to be used for the AC power supply. Cables are listed based on the country type and the Chassis type selected.</p>
Redundant Power Scheme	<p>Choose the redundant power scheme from the drop-down list to configure the number of working and protected power units for the chassis.</p> <p>For NCS 2000 site, the options available are based on the chassis type. For M15 chassis, the options available are 1+0, 1+1, 2+0, 2+1, 3+0, 3+1, 2+2, 3+1 is the default redundancy power scheme for M15 DC chassis and 2+2 is the default redundancy power scheme for M15 AC chassis. For example, if you choose 3+1 redundant power scheme, there are 3 working power units and 1 protected power unit.</p> <p>For M6 chassis, the options available are Auto, Yes, and No.</p>
Raman Adapter Share	<p>This option is available only for the OLA site. By default, this check box remains checked. This option indicates that MF-2LC-ADP can be shared with EDRA amplifiers and not with RAMAN amplifiers irrespective of the default selection.</p>

Properties	Description
ECU Type	<p>Choose the External Connection Unit (ECU) type from the drop-down list. The options available are based on the chassis type. By default, the ECU applicable for M15 is listed.</p> <ul style="list-style-type: none"> • ECU—Has 12 USB 2.0 ports and supports IEEE1588v2 PTP, time-of-day (ToD), and pulse-per-second (PPS) inputs. • ECU-S—Similar to ECU except that it has eight USB 2.0 ports and two USB 3.0 ports. • ECU60-S—Variant of ECU-S introduced for the NCS 2006 when the shelf is powered at -60VDC nominal input voltage. <p>ECU-S and ECU60-S are supported only for M6 chassis.</p>
MF Unit	<p>Choose the mechanical frame for the passive optical modules from the drop-down list. The options available are Auto, MF-6RU/MF-10RU, and MF-1RU.</p> <ul style="list-style-type: none"> • The NCS2K-MF-1RU has four slots for the passive optical modules. • The NCS2K-MF-6RU supports up to 14 single-slot passive optical modules such as any combination of NCS2K-MF-DEG-5, CS2K-MF-UPG-4, or Connection Verification (CV) units. • The NCS2K-MF10-6RU supports up to 10 double-slot passive optical modules such as NCS2K-MF-MPO-16LC=.
Chassis Disaggregation	<p>If you check this check-box, ROADM and transponder cards are placed in different chassis.</p>
Map	
X Coordinate	<p>It represents the longitudinal location of the site. Longitude can be positive or negative (-180 to 180). Negative is west of Greenwich, and positive is eastward.</p>
Y Coordinate	<p>It represents the latitudinal location of the site. Latitude can be positive or negative (- 90–90), north and south of the Equator.</p>
Position Lock	<p>Check this check box to lock the site position on the map.</p>
C Band	
Degree Mesh Type	<p>Choose the mesh type for Flex NG-DWDM site. The available options are:</p> <ul style="list-style-type: none"> • DEG-5/UPG-4 • PPMESH8-5AD <p>DEG-5/UPG-4 is the default value.</p>
Site Type	<p>Displays the type of the site. For example, OLT.</p>

Properties	Description
L0 Platform	Displays the platform.
Degree Type	Displays the type of degree. For example, BRK-8.
Pre Equip Degree	<p>This parameter determines the number of degrees to be considered for the site hardware placement on day 0.</p> <p>The values can be None, Auto, 4, 8, 12 or 16. The default option is None. If you choose None, only the sides that are present in the Cisco ONP GUI are shown. The values in the drop-down list are populated based on the value of scalable up to degree parameter.</p>
SVO	
Chassis License Flush Out	Allows you to flush out the existing chassis license and purchase new chassis license.
SVO Pluggables	<p>You can choose one of the following options from the drop-down list. When you choose Auto, ONS_SC+-10G_SR is the default option.</p> <ul style="list-style-type: none"> • Auto • ONS-SC +- 10G-SR • ONS-SC +-10G-LR <p>Note The SVO pluggables are not applicable for UCS-based SVO network design.</p>
Cisco NMS	
SVO Full License	Enable this check box to add High Availability (Feature and License), Connection Verification license, Flex Spectrum license, and OTDR license packaged in it.
High Availability	Enable this check box to add the High Availability feature to the license package.
Connection Verification License	Enable this check box to add the Connection Verification feature to the license package.
Flex Spectrum License	Enable this check box to add the Flex Spectrum feature to the license package. For SSON networks, Flex Spectrum license is enabled by default.
OTDR License	Enable this check box to add the OTDR feature to the license package.
3rd party NMS	
3rd party Full License	Enable this check box to add NBI (North Bound Interface), Alarm Correlation, Performance Monitoring, and Circuit Provisioning features to the license package.

Properties	Description
NBI	Enable this check box to add the NBI feature to the license package.
Alarm Correlation	Enable this check box to add the Alarm Correlation feature to the license package.
Performance Monitoring	Enable this check box to add the Performance Monitoring feature to the license package.
Circuit Provisioning	Enable this check box to add the Circuit Provisioning feature to the license package.

Step 6 Click **Update**.

Add Contentionless Side to a Site

Contentionless functionality on a site refers to the contentionless add or drop ability of an N-degree ROADM node to accommodate N wavelengths of the same frequency from a single add or drop device. For a ROADM to be contentionless, the number of drop units must be equal to ROADM degrees.

Use the following procedure to add contentionless sides to a ROADM or traffic site.

Before you begin

[Log in to Cisco ONP Web Interface, on page 6.](#)

Procedure

Step 1 Choose **File > Open**.

The **Select Network To Open** dialog box appears.

Step 2 Click the network in which you want to add contentionless sides to a site.

The network opens.

Step 3 Choose **Network > Entity Editor**.

Step 4 Click the site to which you want to add contentionless sides.

Step 5 Click the **Add Contentionless Side** icon.

Step 6 Enter the appropriate value in the **Enter number of contentionless sides** field.

The number of contentionless sides that can be added to a site depends on the type of site, the **Scalable Upto Degree** property. The following table explains the same.

Table 15: Contentionless Sides for Layer-1 SMR

Site Type	Scalable Upto Degree	Number of Contentionless Sides
SMR-20	4	16

Site Type	Scalable Upto Degree	Number of Contentionless Sides
SMR-20	8	12
SMR-20	12	8
SMR-20	16	4
SMR-20	Line	8
SMR-20	Terminal	8
SMR-9	4	5
SMR-9	8	1

Step 7 To add layer-2 SMR-20 contentionless sides, perform the following steps:

- a) Check the **Evolved Mesh** check box.
- b) Choose **Site Type** as *SMR-20* or *Auto*.
- c) Check the **Cascaded SMR** check box.
- d) Choose **Degree Mesh Type** as *DEG-5/UPG-4*.
- e) Click **Update**.

You can add 20 more contentionless sides on each site for layer-2 SMR.

Step 8 Click **OK**.

Modify Number of Contentionless Side Ports for a Site

Use this task to modify the number of contentionless ports for a side in a ROADM site.

Before you begin

[Log in to Cisco ONP Web Interface, on page 6.](#)

Procedure

Step 1 Choose **File > Open**.

The **Select Network To Open** dialog box appears.

Step 2 Click the network in which you want to modify the number of contentionless ports for a side in a ROADM site.

The network opens.

Step 3 Choose **Network > Entity Editor**.

Step 4 Expand a ROADM site and select a contentionless side.

You can view the properties of the side in the right panel.

Step 5 From the **Contentionless Ports** drop-down list, choose the required number of ports.

Click **Update**.

Modify Fiber Properties

Use this task to modify the properties of fiber.

Before you begin

[Log in to Cisco ONP Web Interface, on page 6](#)

Procedure

- Step 1** In the network tree, expand **Fiber**, and click a fiber.
You can view the basic properties of the fiber at the bottom of the network tree.
- Step 2** Modify the following fiber properties as required.

Property	Description
General	
Name	By default, the name of the fiber is based on the number of fibers between the source and destination sites. You can edit the name.
Source	Displays the source site name. This field is noneditable.
Destination	Displays the destination site name. This field is noneditable.
Bidirectional	Indicates whether standard single fiber is used to transmit the data in both directions.

Property	Description
Fiber Type	<p>Select the fiber type. Cisco ONP supports the following fibers, and the default fiber type is G652-SMF.</p> <ul style="list-style-type: none"> • G652-SMF-28E • TWR • MC • TWPlus • TWMinus • TWClassic • FL • TL • G652-SMF • ELEAF • True wave
Length	<p>Displays the span length of the fiber connecting a source and destination site. If necessary, change the span length manually.</p> <ul style="list-style-type: none"> • The Cisco ONP tool automatically updates the fiber length based on the actual geographical map. If you change the fiber length, then the Cisco ONP tool updates the same in the network tree and the map accordingly for the first time. Later, the fiber length does not change, when you drag and drop the sites in the map. • In the network tree pane, expand Fiber and select the fiber couple, A-Z and Z-A. The properties pane displays the fiber couple name, source side, destination side, its span length, loss, and, Polarization Mode Dispersion (PMD) value. • You can enter the different span length and loss values for the individual fibers in a fiber couple.
Network status	<p>Displays the status of the network, whether the network is being deployed or not. If the network is not deployed, it shows the status as UNDISCOVERED.</p>
Business status	<p>Displays the status of the fiber in a business perspective view. If fiber is not deployed, it shows the status as FUTURE. This field is noneditable.</p>
Measurement Units	<p>Choose the measurement unit (Km or Miles) for the fiber span. You can set the measurement unit only for the duct, but not for the fiber pair (couple) or fiber.</p>
Aging Loss [dB]	<p>Enter the aging loss value for the fiber.</p>

Property	Description
DCN Extension	Check this check box to enable the default use of data connection network (DCN) extension on each span in the project. This setting implies that the optical service channel (OSC) channel is not used to connect the two nodes.
OSC FrameType	Choose the OSC frame type. The options available are: <ul style="list-style-type: none"> • Auto • OC3 Frame • GE Frame • FE Frame The default option is Auto. When set in Auto, Cisco ONP uses FE Frame as the preferred frame type.
Aging Factor	Enter the number to fiber aging factor.
Physical	
Length-Based Loss	The fiber loss value is automatically calculated based on length and loss coefficient, when you check this option.
Tot SOL Loss w/o connectors	Enter the start of life fiber loss value for each span, excluding the connector concentrated loss.
Factors	
Loss[dB]	Enter the value of the SOL fiber loss per kilometer used to calculate the loss of each span in the network.
Raman Amplification	
Raman Amplified	Enable Raman Amplification on the ducts.

Step 3 Click **Update**.

Step 4 To modify advanced properties of the fibers, click **Show Advanced Properties**, or choose **Network > Entity Editor**.

Step 5 Click the **FIBER** tab in the **Entity Editor** window.

Step 6 Choose the fiber and modify the following properties in the right pane.

Property	Description
General	
Aging loss	Enter the aging loss value.
DCN Extension	Enable the default use of data connection network (DCN) extension on each span in the network.

Property	Description
OSC Frame Type	Choose the OSC frame type. The options available are Auto, OC3 Frame, Gigabit Ethernet Frame, and Fast Ethernet Frame. The default option is Auto. When set in Auto, Cisco ONP uses Fast Ethernet Frame as the preferred frame type.
Aging Factor	Enter the number to factor fiber aging. This factor is multiplied by the SOL total span loss without connectors.
Physical	
Connector Loss A	Connector Loss at Source Site [dB]
Connector Loss B	Connector Loss at Destination Site [dB]
Factors	
Loss Coefficient [dB/km]	Loss is calculated based on the loss coefficient.
QD C-Band	Displays the secondary order dispersion for C-band.
CD C-Band	Displays the secondary order dispersion for L-band.
RD Factor	Displays the random dispersion value.
Extended	
Effective Mode Area	Displays the effective mode area [μm^2]
SRS tilt coefficient	Displays the Stimulated Raman Scattering tilt coefficient on the band.
DRBS coefficient	Displays the Rayleigh Scattering capture coefficient.
N2	Nonlinear index of refraction [$1\text{e-}16 \text{ cm}^2/\text{W}$]
LFBR	Length of individual fibers for sigmaDSP [Km]
Totals (The properties under Totals are noneditable)	
PMD	Displays the Polarization Mode Dispersion (PMD) value.
Loss EOL	Displays the total loss EOL calculation.
Loss SOL	Displays the total loss SOL calculation.
CD C-Band	Displays the total chromatic dispersion for the C-band.
QD C-Band	Displays the secondary order dispersion for C-band.
RD	Displays the random dispersion value.

Step 7 Click **Update**.

Modify Fiber Couple Properties

Use this task to modify properties of the fiber couple.

Before you begin

[Log in to Cisco ONP Web Interface, on page 6.](#)

Procedure

- Step 1** In the network tree, expand **Fiber**, and drill down up to a fiber couple and click the fiber couple. You can view the basic properties of the fiber couple at the bottom of the network tree.
- Step 2** Modify the following fiber couple properties as required.

Property	Description
General	
Name	By default, fiber couple is named based on the fiber name followed by COUPLE-AZ or COUPLE-ZA. The sides that are connected by the fiber couple are indicated inside brackets. The name is noneditable.
Source Side	Displays the source side name. This field is noneditable.
Destination Side	Displays the destination side name. This field is noneditable.
Length	Automatically displays the span length of the fiber connecting a source and destination side. Change the span length manually, if necessary. You can enter the different span length and loss values for the individual fibers in a fiber couple.
Physical	
Tot SOL Loss w/o connectors	Enter the start of life fiber loss value for each span, excluding the connector concentrated loss.
Factors	
Loss coefficient [dB]	Enter the value of the SOL fiber loss per kilometer used to calculate the loss of each span in the network.
Totals	
Loss SOL	Displays the total loss SOL calculation.
Loss EOL	Displays the total loss EOL calculation.

- Step 3** Click **Update**.

- Step 4** To modify advanced properties of the fiber couple, click **Show Advanced Properties**, or choose **Network > Entity Editor**.
- Step 5** Click the **FIBER** tab in the **Entity Editor** window.
- Step 6** Choose the fiber and drill down to the fiber couple, and modify the following properties in the right pane.

Property	Description
Physical	
Connector Loss A	Connector Loss at Source Site [dB]
Connector Loss B	Connector Loss at Destination Site [dB]
Factors	
PMD coefficient	Displays the PMD coefficient.
Totals (The properties under Totals are noneditable)	
PMD	Displays the PMD value.
Loss EOL	Displays the total loss EOL calculation.
Loss SOL	Displays the total loss SOL calculation.
CD C-Band	Displays the total chromatic dispersion for the C-band.
QD C-Band	Displays the secondary order dispersion for C-band.
RD	Displays the random dispersion value.

- Step 7** Click **Update**.

Modify Service Properties

Use this task to modify the properties of the service.

Before you begin

[Log in to Cisco ONP Web Interface, on page 6.](#)

Procedure

- Step 1** In the network tree, expand **Services** and click a service.
You can view the basic properties of the service at the bottom of the network tree.
- Step 2** Modify the following service properties as required.

Property	Description
General	
Name	By default, the service name is based on the source and destination sites and the number of services between them. You can edit the name. For example, if there are two services between site 1 and site 2, the names of the services are Site-1-Site-2-1 and Site-1-Site-2-2, respectively.
Type	Choose the types of service.
Protection	Choose the protection type from the drop-down list. Options available are: <ul style="list-style-type: none"> • Unprotected • 1+1 • Disjoint • S+NS • 1+R • 1+1+R • 1+1+R+R For more information on protection types, see Supported Protection Schemes , on page 3.
Source	Displays the source site name.
Destination	Displays the destination site name.

Step 3 Click **Update**.

Step 4 To modify advanced properties of the service, click **Show Advanced Properties** or choose **Network > Entity Editor**.

Step 5 In the **Entity Editor** window, click the **Service** tab.

Step 6 Choose the service under the network tree, and modify the following properties in the right pane.

Property	Description
General	
Tertiary Source	From the drop-down list, select the possible site as a tertiary source.

Property	Description
Tertiary Destination	<p>From the drop-down list, select the possible site as a tertiary destination.</p> <p>Tertiary source and tertiary destination are enabled only when you select the protection scheme as Unprotected Disjoint.</p> <p>You can select either tertiary destination or both tertiary source and tertiary destination.</p> <ul style="list-style-type: none"> • If you select only the tertiary destination, the demand is created between the source and destination and between the source and tertiary destination. These do not have common fibers in the path, which are disjoint. • If you select both tertiary source and tertiary destination, two unprotected demands are created between the source to destination, and tertiary source to tertiary destination. The demands are disjoint to each other.
Path Forcing	
Primary Path	Cisco ONP automatically selects the shortest path as working path and also allows you to force the path manually.
Secondary Path	Secondary path is the protected path when the primary path fails. This path is the second best path after the primary path.
Primary Path Fiber	Primary path fiber is forcing path for working trail.
Secondary Path Fiber	Secondary path fiber is for protected service, forcing path for the protected trail.
Primary Path Channel	Primary path channel is tagging any existing wave as working trail.
Secondary Path Channel	Secondary path channel is for protected service, forcing existing waves for the protected trail.
Regeneration Platform	Displays the platform of the regeneration site
Regen Sites	Choose the regeneration site.
Wavelength	Click Edit to choose the wavelength. The default option is Auto.
Section Wavelength(s)	Displays the selected Wavelength .
Regeneration Platform	Displays the platform of the regeneration site
Regen Sites	Choose the regeneration site.
Wavelength	Click Edit to choose the wavelength. The default option is Auto.
Section Wavelength(s)	Displays the selected Wavelength .
Restoration 1 Path Forcing (Available for 1+R, 1+1+R, 1+1+R+R)	

Property	Description
Path	Cisco ONP automatically selects the first restoration path.
Fiber	Choose the first restoration path fibers.
Restoration 2 Path Forcing (Available for 1+1+R+R)	
Path	Cisco ONP automatically selects the second restoration path.
Fiber	Choose the second restoration path fibers.

- Note**
- Ensure that you force both primary and secondary path fiber or channel for protected service. Also ensure that the wave type is same for both primary and secondary paths. While doing path forcing, make sure that you perform an end-to-end path forcing from the source to the destination. Analysis fails if the partial path is forced.
 - Force the wave path for the wave, which is tagged to the service.
 - In case of protection type: 1+1+R+R, 1+1+R, and 1+R, you can force a path in restoration path1 or restoration path2 Fiber that is forced in primary or secondary path Fiber.

Step 7 Click **Update**.

Services Aggregation

Table 16: Feature History

Feature Name	Release Information	Feature Description
Services Aggregation	Cisco ONP Release 4.1	Services aggregation feature allows two or more services to share the same trunk port or channel. By default, the services are added to the DefaultGroup. You can also export the aggregation reports.

Services aggregation indicates whether two or more services can share the same trunk port or channel. The aggregation is defined based on the properties of the Service Group. When you add services to the Traffic site (of the type 1K-2K-4K) in an SSON network, a **DefaultGroup** is created under the **Services** in the network tree. The services that you add, are associated to the **DefaultGroup**.

Create a New Service Group

Use this task to create a new service group:

Before you begin

[Log in to Cisco ONP Web Interface, on page 6](#)

Procedure

- Step 1** Choose **File > Open**.
The **Select Network To Open** dialog box appears.
- Step 2** Click a network, where you want to create a new service group.
The network opens.
- Step 3** Right-click **Services** under the network tree and choose **Create Service Group**.
A new service group gets created under the Services.

Modify Service Group Properties

Use this task to modify the properties of service group.

Before you begin

[Log in to Cisco ONP Web Interface, on page 6.](#)

Procedure

- Step 1** In the network tree, expand **Services** and click a service group.
You can view the basic properties of the service at the bottom of the network tree.
- Step 2** Modify the following service properties as required.

Property	Description
General	
Name	By default, Cisco ONP provides a servive group name. For example, Group-1. You can edit the name. For example, if there are two services between site 1 and site 2, the name of the services are Site-1-Site-2-1 and Site-1-Site-2-2, respectively.
Demand Types	Choose the demand type. For default group all demand types are available, and you cannot edit them.
Default Group	Indicates whether the service group is a default group or a user created group.
NCS 4 K	

Property	Description
Exclusive LC Usage	<p>Indicates whether the services belonging to this group must have an exclusive Line Card (LC) or not.</p> <p>For example, when you check this check box, neither the Client LC nor the Trunk LC of the services belonging to this group can be shared by services belonging to any other groups.</p>
Symmetric Aggregation	<p>Indicates whether this group allows aggregation of only symmetric services. Services are symmetric if they have same protection scheme. Following are the various protection schemes:</p> <ul style="list-style-type: none"> • Unprotected • 1+R • 1+1 • 1+1+R • 1+1+R+R <p>For Example, all “1+1” services are symmetrical.</p> <p>If you check this check box, this service group allows aggregation of only symmetrical services.</p> <p>For example, “Unprotected” can be aggregated only with “Unprotected”, “1+R” only with “1+R”, “1+1” only with “1+1”, and so on.</p> <p>If this check box is unchecked, this service group allows aggregation of symmetrical and unsymmetrical services together.</p> <p>For example, “Unprotected” can be aggregated with either “Unprotected”, “1+R”, “1+1”, “1+1+R” or “1+1+R+R”.</p> <p>See Aggregation Rules, on page 92.</p>
NCS 1 K	
Exclusive LC Usage	Same as NCS 4 K.
Symmetric Aggregation	Same as NCS 4 K.

Step 3 Click **Update**.

Aggregation Rules

Following are the rules for any two services (symmetrical or nonsymmetrical) to be aggregated:

- The services must have the same Source and Destination.
- The services must have same paths for the same path types.

For example:

- For symmetric aggregation between two “1+1” services, the working path of the first service must match with the working path of the second service and the protection path of the first service must match with the protection path of the second service.
- For non-symmetric aggregation between “1+1” and “1+1+R” services, the working path of the first service must match with the working path of the second service and the protection path of the first service must match with the protection path of the second service. The restoration path of second service can be anything.
- The services must be configured to use same wavelength for same path types.
- If the wavelength is set to “auto”, it is flexible to be aggregated with other “auto” wavelength or a fixed wavelength.
- The services must be configured to use same trunk mode for same path types.
- The services must be configured to use same regeneration sites for same path types.



Note Demand Type is not used as a constraint for aggregation (except for trunk capacity availability).

Associate a Service to the Newly Created Group

By default, the services are associated to the **DefaultGroup**. But you can change the group.

Before you begin

[Log in to Cisco ONP Web Interface, on page 6.](#)

Procedure

- Step 1** In the network tree, click the service that you want to associate to a group.
You can view the basic properties of the network at the bottom of the network tree.
- Step 2** Choose the group from the **Service Group** drop-down list.
- Step 3** Click **Update**.

Note For an LNI imported network, by default, all the services are present in the Default group. Only when you upgrade the LNI imported network for the first time, you can move the services to other newly created Service Groups without having to unlock them. On subsequent upgrades, you must unlock the services to facilitate the movement between Service Groups. Also, the Service Groups are in locked state in the upgrade mode, unless a complete Network-level unlock has been performed.

What to do next

Export Aggregation Reports

Use this task to export the service aggregation reports:

Before you begin

[Log in to Cisco ONP Web Interface, on page 6.](#)

Procedure

- Step 1** Choose **File > Open**.
The **Select Network To Open** dialog box appears.
- Step 2** Click an analyzed network.
The network opens.
- Step 3** Choose **Export > Service Aggregation**.
- Step 4** Save the aggregation report in the form of an Excel sheet to your local system.
-

Modify Wave Properties

Use the following task to modify the properties of the wave.

Before you begin

[Log in to Cisco ONP Web Interface, on page 6.](#)

Procedure

- Step 1** In the network tree, expand **Waves**, and click a wave.
You can view the basic properties of the wave at the bottom of the network tree.
- Step 2** Modify the following wave properties as required.
- Step 3** Click **Update**.
-

Modify Media Channel Properties

Use the following task to modify properties of the media channel.

Before you begin

Log in to Cisco ONP Web Interface, on page 6.

Procedure

Step 1 In the network tree, expand **Media Channels**, and click a media channel.
 You can view the basic properties of the media channel at the bottom of the network tree.
 Alternatively, you can choose **Network > Entity Editor > Services**, expand **Media Channels**, and click a media channel to view the properties.

Step 2 Modify the following properties as required.

Property	Description
General	
Label	By default, the media channel is named based on the source and destination sites and the number of media channels between them. You can edit the name. For example, if there are two media channels between site 1 and site 2, they are named as Site-1-Site-2-1 and Site-1-Site-2-2, respectively.
Source Site	Displays the source site name.
Destination Site	Displays the destination site name.
Traffic Type	Choose the traffic type from the drop-down list. The available options are: <ul style="list-style-type: none"> • Alien • 100GE • 10GE LAN PHY • 40GE LAN PHY • Fiber Channel 10G • Fiber Channel 16G • Fiber Channel 8G • OC-192/STM-64 • OTU2 • OTU2e • OTU4

Property	Description
Protection Type	<p>Choose the protection type.</p> <ul style="list-style-type: none"> • Unprotected • Client 1+1 <p>For more information on protection types, see Supported Protection Schemes , on page 3.</p> <p>For Client 1+1, ensure that the sites have contentionless sides for the analysis to be successful. By default, Cisco ONP finds both span and node disjoint path for Client1+1 protected waves, but allows you to force span and node disjoint path.</p>
Forecast	Check this check box to change a present wave to a forecast wave.
Encryption	Check this check box to enable encryption.

Step 3 Click **Update**.

Modify Trail Properties

Use this task to modify the properties of the trail.

Before you begin

[Log in to Cisco ONP Web Interface](#), on page 6.

Procedure

Step 1 In the network tree, expand **Waves**, or **Media Channels**, drill down up to trail and click a trail. The basic properties of the trail are displayed at the bottom of the network tree.

Step 2 Modify the following trail properties as required.

Property	Description
General	
Label	Displays the name of the trail. You can edit the name.
Path of Wave	Select a fiber from the drop-down list.
Regen Sites	Select the regeneration site.
Source Site	Displays the source site name.
Destination Site	Displays the destination site name.
Wavelength	Click Edit to choose the wavelength. The default option is Auto.

Property	Description
Central Wavelength	Click Edit to choose the central wavelength. The default option is Auto.
Multicarrier	Indicates whether the transmission is a multicarrier transmission.
Trunk Mode	Choose the trunk mode from the drop-down list.

Step 3 To modify the advanced properties of the trail, click **Show Advanced Properties** or choose **Network > Entity Editor**.

Step 4 In the **Entity Editor** window, click the **Service** tab.

Step 5 Expand **Waves**, or **Media Channels**, under the network tree, drill down to the trail, click the trail, and modify the following properties that are displayed in the right pane.

Property	Description
General	
OSNR Forward [dB]	Displays the forward optical signal to noise ratio.
OSNR Reverse [dB]	Displays the reverse optical signal to noise ratio.
Colorless	Indicates whether colorless functionality is enabled on the trail.
Omni-directional	Indicates whether omni-directional functionality is enabled on the trail.
Contentionless	Indicates whether contentionless functionality is enabled on the trail.
Filtering Penalty	Displays the value of the penalties that are caused by the different filter types (OADM, and ROADM).
OTN	
First ODU	Displays the first Optical Data Unit.
Last ODU	Displays the last Optical Data Unit.
SRLGs	Displays the SRLGs associated with the trail.
OTN Hops	Displays the number of OTN hops.
Quantity	Displays the number of OTN services on the trail.
Src	
Src Card Type	Choose the card used in the source site. See Supported Cards and Pluggables, on page 139 and Supported Aliens, on page 151 for more information on the list of supported cards.

Property	Description
Src Client Interface	Choose the pluggable from the drop-down list. The pluggables suitable for the chosen card type are displayed. See Supported Cards and Pluggables, on page 139 for more information on the list of supported pluggables. The pluggable FR-1(QSFP-100G-FR-S) is supported on the client ports of the 400G-XP LC starting from NCS 2000 Release 11.1.0.
Src Trunk Type	Choose the trunk type from the drop-down list.
Src Contentionless Side	Choose the contentionless side from the drop-down list.
Dst	
Dst Card Type	The destination card type is auto populated based on the source card type chosen.
Dst Client Interface	Choose the pluggable from the drop-down list. The pluggables suitable for the chosen card type are displayed.
Dst Trunk Type	Choose the trunk type from the drop-down list.
Dst Contentionless Side	Choose the contentionless side from the drop-down list.

Step 6 Click **Update**.

Modify Section Properties

Use this task to modify properties of the section.

Before you begin

[Log in to Cisco ONP Web Interface, on page 6.](#)

Procedure

Step 1 In the network tree, expand **Waves**, drill down up to section and click a section.
You can view the basic properties of the section at the bottom of the network tree.

Step 2 Modify the section properties as required.

Section and trail have the same properties. Refer [Modify Trail Properties, on page 96](#) for the descriptions of the properties.

Step 3 Click **Update**.

Modify Side Properties

Use this task to modify the properties of a side in a site.

Before you begin

[Log in to Cisco ONP Web Interface, on page 6.](#)

Procedure

Step 1 In the network tree, Choose **Sites > Site > Site domain > Side**.

Step 2 To modify the side properties, perform the following steps:

- a) Click **Show Advanced Properties**.
- b) In the right pane of **Entity Editor** window, modify the following properties of the side.

Note You cannot edit the properties of the Pass through site side.

Property	Description
General	
Label	Displays the label of the side.
Type	Displays the type of the side. The available options are: <ul style="list-style-type: none">• Line• Contentionless

- c) Click **Update**.
-

Modify C-Band Amplifier Properties

Table 17: Feature History

Feature Name	Release Information	Feature Description
Manual Editing of Raman COP values	Cisco ONP Release 4.1	This feature allows you to edit the crosstalk values of the Raman COP amplifier in the SSON network, starting from NCS 2000 Release 11.1.

Use this task to modify the properties of a c-band amplifier in a site.



Note Make sure that SMR card is forced on the site before you update the c-band amplifier properties.

Before you begin

[Log in to Cisco ONP Web Interface, on page 6](#)

Procedure

Step 1 In the network tree, choose **Sites > Site > Site domain > Side > C-Band**.

Step 2 To modify the amplifier properties, perform the following steps:

- a) Click **C-Band Amplifier**.

You can view the properties of the C-Band Amplifier at the bottom of the network tree. For more information, see [Supported Amplifiers, on page 153](#).

- b) Modify the following properties of the amplifier:

You can also modify the properties by choosing the **C-Band Amplifier** under **Network > Entity Editor**.

Options	Description
General	
Raman COP Tilt	The default value is Auto. You can enter a value.
Pre Tilt	The default value is Auto. You can enter a value.
Raman Tilt	The default value is Auto. You can enter a value.
Booster Tilt	The default value is Auto. You can enter a value.
From Fiber	

Options	Description
Pre Amp	<p>Choose a preamplifier from the drop-down list. The default value is Auto. To enable this field for ROADM and Traffic nodes, you must choose SMR-9 or SMR-20 from the Site Type drop-down list under the Site properties.</p> <p>If you choose SMR-9, the available options are:</p> <ul style="list-style-type: none"> • SMR9-FS-EDFA17-PRE • SMR9-FS-EDFA24-PRE • SMR9-FS-EDFA24-PRE <p>If you choose SMR-20, the available options are:</p> <ul style="list-style-type: none"> • SMR20-FS-EDFA17-PRE • SMR20-FS-EDFA24-PRE <p>For the OLA site, the available options are:</p> <ul style="list-style-type: none"> • EDFA35-35-PRE • EDFA35-24-PRE • OPT -EDFA-17 • OPT -EDFA-24
Output Power	The default value is Auto. You can enter a value.
Attenuator In	<p>This field is enabled only when you choose a preamplifier. Choose an attenuator from the drop-down list. The available options are:</p> <ul style="list-style-type: none"> • ATT-LC-2 • ATT-LC-3 • ATT-LC-5 • ATT-LC-7 • ATT-LC-10 • ATT-LC-12 • ATT-LC-15 • ATT-LC-18

Options	Description
Attenuator Out	<p>This field is enabled only when you choose a preamplifier. Choose an attenuator from the drop-down list. The available options are:</p> <ul style="list-style-type: none"> • ATT-LC-2 • ATT-LC-3 • ATT-LC-5 • ATT-LC-7 • ATT-LC-10 • ATT-LC-12 • ATT-LC-15 • ATT-LC-18
To Fiber	
Booster	<p>The default value is Auto. To enable this field for ROADM and Traffic nodes, you must choose SMR-9 or SMR-20 from the Site Type drop-down list under the Site properties.</p> <p>If you choose SMR-20, the default booster is 20SMR-FS-BST.</p> <p>If you choose SMR-9, default booster is SMR9-FS-EDFA-BST.</p> <p>For the OLA node, the available options are:</p> <ul style="list-style-type: none"> • EDFA35-35-BST • EDFA35-24-BST • OPT -EDFA-17 • OPT -EDFA-24
Output Power	The default value is Auto. You can enter a value.

Options	Description
Attenuator In	<p>This field is enabled only when you choose a booster. Choose an attenuator from the drop-down list. The available options are:</p> <ul style="list-style-type: none"> • ATT-LC-2 • ATT-LC-3 • ATT-LC-5 • ATT-LC-7 • ATT-LC-10 • ATT-LC-12 • ATT-LC-15 • ATT-LC-18
Attenuator Out	<p>This field is enabled only when you choose a booster. Choose an attenuator from the drop-down list. The available options are:</p> <ul style="list-style-type: none"> • ATT-LC-2 • ATT-LC-3 • ATT-LC-5 • ATT-LC-7 • ATT-LC-10 • ATT-LC-12 • ATT-LC-15 • ATT-LC-18
Raman Amplification	

Options	Description
Raman Amp	<p>Choose the Raman amplifier from the drop-down list.</p> <p>Note To force the RAMAN amplifier, you must enable RAMAN amplified on the fiber, else the Raman Amp is disabled, and network analysis fails.</p> <p>The available options for ROADM and Traffic sites are:</p> <ul style="list-style-type: none"> • RAMAN-CTP • RAMAN-COP-CTP <p>Raman Amp can be forced only between two nodes.</p> <p>The available options for the OLA site are:</p> <ul style="list-style-type: none"> • EDRA1-26 • EDRA1-35 • EDRA2-26 • EDRA2-35 • RAMAN-CTP
Raman CTP Gain	Enter a value.
Raman COP Gain	Enter a value. This field is enabled only when you choose RAMAN-COP-CTP.
Static Data	<p>By default, this option is disabled. Enable it to edit the crosstalk values of the Raman COP amplifier.</p> <p>Note Static data is supported from Release 11.1 for SSON network.</p>
Linear XT Avg	Edit the value of average linear crosstalk.
Linear XT Six	Edit the value average linear crosstalk sigma.
NonLinear XT Avg	Edit the value of average nonlinear crosstalk.
NonLinear XT Sig	Edit the value of average nonlinear crosstalk sigma.

c) Click **Update**.

Sort the Network Elements

You can sort the sites, services, fibers, waves, and SRLG in ascending or descending order. This feature is helpful for huge networks, to find out the required site, fiber, waves, or SRLG names quickly. Right-click the network element, for example **Sites** and choose **Ascending** or **Descending**. You can sort based on alphabets, numbers, or alphanumeric.

Regeneration Support

In optical networks, as the fiber length increases, a loss in the signal ratio and power could occur due to attenuation and dispersion. You require a regenerator to recreate the weak and distorted optical signals through reamplification, regeneration, and retiming processes. The regenerators remove noise and distortion, convert the optical signal to electrical signal, and then convert the signals back to optical signals (OEO conversion). Cisco ONP supports creation of regeneration sites in the network.



Note A regenerator site can only be a ROADM site.

Create a Regeneration Site

Table 18: Feature History

Feature Name	Release Information	Feature Description
Wavelength Forcing at the Section Level	Cisco ONP Release 4.1	This feature allows you to assign different wavelengths for different sections of the Regen sites.

Use the following procedure to create a regeneration site in the network.

Before you begin

[Log in to Cisco ONP Web Interface, on page 6.](#)

Procedure

- Step 1** Choose **File > Open**.
The **Select Network To Open** dialog box appears.
- Step 2** Select a network from the list of networks. This opens the selected network's map.
You can also add a regeneration site when you are designing a new network or upgrading a network.
- Step 3** In the network tree, expand **Waves**, select a wave and drill down to its trail.

Note If the network is an SSON network, you see **Media Channels** instead of waves. Expand **Media Channels**, and drill down to its trail.

Step 4 Click the trail.

You can view the properties of the trail at the bottom of the network tree.

Step 5 From the **Regen Sites** drop-down list, select a regeneration site.

Note If you select a fiber from the **Path of Wave** drop-down list, you cannot select any regeneration site to force a path. Similarly, if you select a regeneration site, you cannot force a path for the wave. However, if you want to force a fiber, select the fiber from the **Path of Wave** drop-down list available under the section properties.

Step 6 (Optional) Select the wavelength of each section in the properties for non-SSON network.

Note For the SSON network, you can select the wavelength only at the trail level.

Step 7 Click **Update**.

A new section is added along with the existing section under the trail, whenever a regeneration site is created. Regeneration can be performed using any two cards back-to-back or with a dedicated regenerator card.

Step 8 Click **Analyze** to analyze the network.

After analysis, if you click trail or section in the network tree, the map highlights the trail in orange color, and the section in green color.

Note You can assign different wavelengths for different sections. The **Central Wavelength** is denoted as a *, when different wavelengths are assigned for different sections.

Multidegree ROADM

In multidegree ROADM, sites have two or more sides and face two or more fibers spans. You can select the degree of a node from the Cisco ONP GUI. The values are 2, 4, 8, 12, and 16 for Evolved Mesh (EV) ON and OFF scenarios. The default value is 4. Degrees 5, 9, and 13 are not supported. EV flag is editable.

Prerequisites for Cascaded SMR

- The **Structure** field under **C Band** in the **Entity Editor** must be Multidegree.
- The **Site Type** field under **C Band** in the **Entity Editor** must be SMR-20.
- The **Evolved Mesh** check box under **General** in the **Entity Editor** must be checked.
- The **Degree Mesh Type** field under **C Band** in the **Entity Editor** must be Auto or DEG-5/UPG-4.
- The **Mpo16TOMpo8** field under **General** in the **Entity Editor** must be MPO16To2MPO8 cable.
- By default, the **Cascaded SMR** check box is unchecked, but you can edit in the design mode as a site property. Check the **Cascaded SMR** check box for contentionless side creation. L2 SMR is supported for both SSON and Non-SSON networks.

- You can edit the **Cascaded SMR** check box when **Evolved Mesh** is ON and the SMR-20 card is selected. You can create Layer 2 SMR sides only after you check the **Cascaded SMR** check box.
- You can create contentionless sides manually and force the contentionless ports. The default value is 16 for the contentionless ports. The range of values is 0–16.

Limitations

- Supports only contentionless add/drop demands.
- Supports Layer-2 SMR for SMR-20 card only.



CHAPTER 5

View Network Reports

- [Network Reports, on page 109](#)

Network Reports

Cisco ONP provides network reports, which are listed under the report availability tabs. Reports are available depending on whether a network is analyzed, or not. Reports are also available in site properties after analyzing the network.

Cisco ONP provides the following reports:

- Dashboard
- Elements
- Map
- BOM
- Layout
- Results

The Cisco ONP home page has multiple tabs to access the reports of the analyzed network. You can also view the reports for specific site, fiber, or wave properties by clicking the respective report in the Network Tree pane.

View Reports in the Dashboard Tab

The **Dashboard** tab provides the total count of sites, fibers, SRLGs, services, waves/media channels, and messages that exist in the network.



Note The Dashboard report shows incorrect count of 100G and 200G waves for transponder cards. You can view the details in the Optical report and Traffic report.

View Reports in the Elements Tab

The **Elements** tab provides detailed reports of the network elements and messages.

Report	Description
Sites	Shows the site information, which consists of the name of the sites, type and their X and Y coordinate values.
Fibers	Shows the information about the fiber length between the source and the destination for corresponding sites.
Services	Shows the service type, source and destination sites for particular service, quantity, protection type, and status. For each service, the report shows the primary path, secondary path, and their status.
Waves	The Waves report shows the number of waves available in the network and the wave utilization. Click each wave to view the following details: <ul style="list-style-type: none"> • Wave—Consists of a wave UID and its source and destination sites. • Wave Details—Provides details of wave OSNR, channel path, OTN services associated to wave and excluded channels. • Channels—Port details of the source and destination cards, wavelength that is used, and its utilization demands. • Optical Results—Provides details of optical parameters such as OSNR, SOL, EOL, Power margin, CD, and PMD.
SRLGs	Lists the names of created SRLGs and their fiber details. Click Export at the bottom to export the report in .xlsx format.
Messages	Shows messages that are related to errors occurred while analyzing the network. By default, only critical messages for the analyzed network are listed here. You can disable the Critical Only toggle button to view all messages.



Note Click the Pop-up icon to view the reports in a larger, resizable window.

View Details of the BOM Report

Table 19: Feature History

Feature Name	Release Information	Feature Description
MLP Brownfield with Diff BOM	Cisco ONP Release 4.1	<p>This feature allows you to perform the following:</p> <ul style="list-style-type: none"> • Compare the BOMs of two or more LNI imported networks. • Upgrade brownfield network. • Upgrade the Cisco ONP network with traffic sites.

The BOM report consists of individual site price lists and the total BOM of the network. Click each site to view BOM of OTN and DWDM separately.

You can compare the BOM of the existing network with other networks using the **Compare with: Other Networks** option.

You can export the BOM details in the form of a spreadsheet, by clicking **Export** and saving it to your local system.



Note You can also compare the BOM of LNI imported networks.



Note From Release 4.2, Cisco ONP supports the listing of new licensed PIDs for the SMR-20 card. The PIDs are chosen based on the demand. This is applicable only for the newly designed and upgraded networks.

- NCS2K-FSSMR-2-LIC=—20-port FS-SMR licensed to enable two ports
 - E-NCS2K-1P-LIC=—Software license to enable one port on licensed 20-port FS-SMR
 - E-NCS2K-5P-LIC=—Software license to enable five ports on licensed 20-port FS-SMR
 - E-NCS2K-10P-LIC=—Software license to enable ten ports on licensed 20-port FS-SMR
-

View Details of Layout and Internal Connections

To get the details of layout and internal connections, perform the following steps:

Before you begin

[Log in to Cisco ONP Web Interface, on page 6.](#)

Procedure

Step 1 Click the **Layout** tab on the Cisco ONP home page.

Step 2 Type the site name in the search box.

The site layout is displayed with its racks and cards. Hover the mouse pointer over the transponder card to view the details of slot, PID of the card, and ports. Expand the Ports to view details, such as wavelength and trunk mode. Similarly, hover the mouse pointer over chassis to know the total power consumption.

SVO supports up to 50 UIDs, beyond which, the site layout displays incorrect UID for the chassis.

Step 3 Click the ‘Orange Colored Double Arrow’ symbol on the top of search box to view Internal Connections. You can view the patch details of every site.

Step 4 Click **Export as png** to export the layout as an image file.

Export Internal Connections

Cisco ONP allows you to export internal fiber connection in two ways, either at Site-level or Network-level. To export the details, right-click the internal fiber connection or site, and click **Export**.

Compare the Installation Parameters of Two Networks

Table 20: Feature History

Feature Name	Release Information	Feature Description
UI Revamp of Optical Reports	Cisco ONP Release 4.1	This feature improves the user experience while comparing the installation parameters and optical reports of two networks.

Use this task to compare the installation parameters of two networks.

Before you begin

[Log in to Cisco ONP Web Interface, on page 6.](#)

Procedure

Step 1 Click the **Results** tab on the Cisco ONP home page.

Step 2 Click **Installation Parameters**.

Step 3 Click **Other Networks**.

Step 4 From the list of networks, choose the network to compare with.

You can find a new parameter called **diffBy**.

Note You can click **Clear** to stop the comparison of two networks.

Compare the Optical Report of Two Networks

Use this task to compare the optical report of two networks.

Before you begin

[Log in to Cisco ONP Web Interface, on page 6.](#)

Procedure

- Step 1** Click the **Results** tab on the Cisco ONP home page.
- Step 2** Click **Optical Report**.
- Step 3** Click **Other Networks**.
- Step 4** From the list of networks, choose the network to compare with.

You can find two values in the optical parameters such as Protection, SOL, EOL, SE, P/F, Source, Src Colorless, Src Contentionless, Destination, Dst Colorless, Dst Contentionless, Wavelength, Src Tx Type, Dst Tx type, Span, Suggested Regen Locations, BER Target, SOL OSNR, EOL OSNR, SOL OSNR margin, EOL OSNR margin, SOL RX, EOL RX, SOL Power Margin, EOL Power Margin, SOL Overload, EOL Overload, Residual CD, CD robustness, Single-Channel NLE Status, Multi-Channel NLE Status, Min GB, Filtering Penalty, PMD, RX Atten, TX Atten, Encryption, SNLE Components, MNLE Components, OSNR Penalties and POWER Penalties.

Note You can click **Clear** to stop the comparison of two networks.

View Optical Results

Use this task to view the details of optical reports, installation parameters, traffic reports, and connection reports.

Before you begin

[Log in to Cisco ONP Web Interface, on page 6.](#)

Procedure

- Step 1** Click the **Results** tab on the Cisco ONP home page.
By default, the **Optical Report** tab appears. Each row in the tab shows the performance of one optical path:

Optical Parameter	
Name	Displays the ID number of the wave and aggregated waves. ID is automatically generated based on the site name.
Protection	Displays the protection type of the wave.
SOL	Displays an icon indicating the results summary of the analysis that is run with Start of Life (SOL) fiber loss values: <ul style="list-style-type: none"> • Green indicates success. • Yellow indicates success with a marginal failure risk. • Orange indicates that the channel has a higher risk of failure. • Red indicates failure.
EOL	Displays an icon indicating the results summary of the analysis that is run with End of Life (EOL) fiber loss values. The indicator shows the optical performance for the path at the end of the fiber life: <ul style="list-style-type: none"> • Green indicates success. • Yellow indicates success with a marginal failure risk. • Orange indicates that the channel has a higher risk of failure. • Red indicates failure.
SE	Indicates a system-related error that may impact the analysis of the design. If the indicator is red, review the messages that are reported at the end of the analysis or determine which units or sites have a problem.
P/F	Displays the present or forecast services indication.
Source	Displays the name of the source site and side; for example, Site 1-E.
Src Colorless	Displays whether the colorless functionality is enabled on source ports.
Src Contentionless	Displays whether the contentionless functionality is enabled on source ports.
Destination	Displays the name of the destination site and side; for example, Site 1-E.
Dst Colorless	Displays whether the colorless functionality is enabled on destination ports.
Dst Contentionless	Displays whether the contentionless functionality is enabled on destination ports.
Wavelength	Displays the wavelength of the optical channel.
Src Tx Type	Displays the type of DWDM unit or pluggable port module that is used at the source of the specific Optical Channel (OCH) trail. The class of the DWDM unit is also displayed.
Dst Tx type	Displays the type of DWDM unit or pluggable port module that is used at the destination of the specific OCH Trail. The class of the DWDM unit is also displayed.
Span	Displays the total span length (source to destination) for this path in kilometers.

Optical Parameter	
Suggested Regen Locations	Displays the regeneration locations.
BER Target	Displays the bit error rate (BER) target for this channel, based on the capability of the channel's optical interface. It is 1.0E-15 for the interfaces using forward error correction (FEC) and 1.0E-12 for interfaces without FEC.
SOL OSNR	Displays the start of life average Optical Signal to Noise Ratio (OSNR) value at the receiver.
EOL OSNR	Displays the end of life average OSNR value at the receiver.
SOL OSNR margin	Displays the SOL OSNR margin calculation. It is the difference between the OSNR value at certain power of the working point of the receiver client and the working area boundary.
EOL OSNR margin	Displays the EOL OSNR margin calculation, which is the difference between the OSNR value at a certain power of the working point of the receiver client and the working area boundary.
SOL RX	Displays the SOL average power that is received at the destination site in dBm.
EOL RX	Displays the EOL average power that is received at the destination site in dBm.
SOL Power Margin	Displays the SOL power budget margin at the receiver in decibels. It is defined as the offset between the receiver working point and the BER curve with margin. A positive value indicates that there are no power problems.
EOL Power Margin	Displays the EOL power budget margin at the receiver in decibels. It is defined as the offset between the receiver working point and the BER curve with margin. A positive value indicates that there are no power problems.
SOL Overload	Displays the SOL overload margin at the receiver in decibels. A positive value indicates that there are no overload problems.
EOL Overload	Displays the EOL overload margin at the receiver in decibels. A positive value indicates that there are no overload problems.
Residual CD	Displays the chromatic dispersion (CD) margin of the demand.
CD robustness	Displays the robustness to chromatic dispersion of the receiver.
Single-Channel NLE Status	Displays the status of alarms if any nonlinear effect (NLE) is present in the demand.
Multi-Channel NLE Status	Provides the status of the nonlinear effect (NLE) on a particular channel or demand due to other channels or demands.
Min GB	Displays the minimum Guard Band (GB) requirement between channels on the 40G CP-DQPSK MXP and 40G CP-DQPSK ME MXP cards, and other transponders in a mixed any-to-any connectivity.
Filtering Penalty	Displays the value of the penalties that are caused by different filter types (OADM, ROADM, and arrayed waveguide grating (AWG)).

Optical Parameter	
PMD	Displays the calculated total Polarization Mode dispersion (PMD) for each circuit. If the overall PMD for the link overcomes the maximum that is allowed, the PMD value is displayed in a red-colored font. The maximum allowed value depends on the client interface. For these special cases, the network must be manually resolved by contacting a Cisco TAC team.
RX Atten	Displays the attenuation at the input of the receiver.
TX Atten	Displays the attenuation at the output of the receiver.
Encryption	Displays the encryption type of the channel. Possible values are N/A, Yes, No.

Step 2 Click **Export Report** to export the optical reports details in an Excel sheet.

Step 3 Click the **Installation Parameters** tab.

The Installation Parameters report shows the values to be set (provisioned) at the installation time on each site in the network.

You can view the installation parameters for **ANS** (automatic node setup), and **ANP** (automatic node provisioning), for each side of the Network Element (NE) in all the sites:

Step 4 Click the **ANS** tab to view the following parameters:

Table 21: ANS Parameters

Parameter	Description
Name	Displays the name of the site
Side	Displays the line side
Position	Displays the rack, shelf number, and slot position of the card where the patch cord originates.
Unit	Displays the name of the card.
Port	Displays the port number where the patch cord originates.
Port ID	Displays the port ID.
Port Label	Displays the name of the port.
Parameter	Displays the name of the parameter to be set, such as RX Power Low.
Value	Displays the name of the value to be set for the parameter.
Measurement Unit	Displays the measurement unit for the related installation parameter value, such as dBm.
Manual Set	Indicates with a Yes or No which parameters must be manually set using the Cisco Transport Controller (CTC) interface.

Step 5 Click the **ANP** tab to view the following parameters:

Table 22: ANP Parameters

Parameter	Description
Name	Displays the name of the site.
Unit ID	Displays the unit (slot number) of the passive units in the shelf.
Shelf ID	Displays the shelf identifier.
Rack Number	Displays the rack number.
Rack Position	Identifies the rack position in the shelf.
Slot Position	Identifies the slot position in the shelf for the card.
Equipment Type	Displays the card type.
Description	Displays the details of the card type.

Step 6 Click the **Traffic Report** tab.

You can view the aggregated demand channel data in the form of the following traffic reports:

Table 23: Traffic Reports

Traffic Report	Description
Demand	Categorizes each demand type. Each demand is further categorized into service, trails, and sections.
Section	Displays the sections under every service.
Src Site	Displays the site name for the optical channel source.
Src Position	Displays the rack, shelf ID, and slot identifiers for the source of the optical channel.
Src Card	Displays the unit name for the optical channel source.
Dst Site	Displays the site name for the optical channel destination.
Dst Position	Displays the rack, shelf ID, and slot identifiers for the destination of the optical channel.
Dst Card	Displays the unit name for the optical channel destination.
Client Service Type	Displays the client service type of the demand; for example, OC-48.
Protection Type	Displays the protection type of the demand

Traffic Report	Description
Encryption	Displays whether the demand is encrypted or not, values are NA, Yes, No.
Wavelength	Displays the wavelength value of the optical channel, and the serial number of the wavelength in the wavelength band.
Max Latency	Displays the latency time for the current circuit. This value includes all the latency components for the circuit, including fiber and DWDM units on the path.

Step 7 Click the **Connections Report** tab.

You can view the patch cord connections related to multi-shelf management. This report is available for the networks starting from NCS 2000 system Release 12.1.0.

Table 24: Connections

Connections Report	Description
Name	Displays the name of the site.
Src Unit Type	Displays the source unit.
Src Position	Displays the rack, shelf, and slot position of the card from which the patch cord originates.
Src ID	Displays the source unit ID.
Src Port Label	Displays the name of the port.
Cable Type	Displays the type of cable.
Dst Unit Type	Displays the source unit.
Dst Position	Displays the rack, shelf, and slot position of the card from which the patch cord terminated.
Dst ID	Displays the destination unit ID.
Dst Port Label	Displays the name of the port.
W/P	Displays whether the connection relates to a present or forecast circuit.

Confidential Banner

Table 25: Feature History

Feature Name	Release Information	Feature Description
Confidential Banner	Cisco ONP Release 4.1	This feature indicates the confidentiality of the reports or results generated by Cisco ONP for a network. The CONFIDENTIAL banner is placed in all the exported reports. It is placed in the first row and first cell of the Excel sheet, followed by a blank row and the contents of the exported report.

The **CONFIDENTIAL** banner is to be present in all the exported reports. It is placed in the first row, first cell of the Excel sheet (.xlsx), followed by a blank row and the contents of the exported report.

The exported reports include:

- Sites
- Fibers
- Services
- Waves
- Traffic
- Failure (Plan and Restore)
- BOM
- Media Channel
- SRLG
- Messages
- Optical Result
- Failure Group
- Connections Report
- Service Aggregation
- IPC (Individual and All sites)



Note

- The **CONFIDENTIAL** banner is present in all the sheets, if multiple sheets are present in the xlsx file.
- The **CONFIDENTIAL** banner is updated, only when you export the reports in .xlsx format.



CHAPTER 6

Backup and Restore Cisco ONP Database

- [Backup Database, on page 121](#)
- [Restore Database Manually, on page 123](#)
- [Restore Database Using Script, on page 125](#)

Backup Database

Based on the database backup configuration on the server, as set by the system admins, you can take the backup of the complete database on a daily, weekly, or monthly basis. Only system admins can access the backup folders and restore them. Backup archive is stored on highly durable NFS share. The following backup archives are available:

- Archives for the last 7 days
- Weekly archives for the last 4 weeks
- Monthly archives for the last 6 months



Note You can change the duration for monthly archives.

Setup Backup

Before you begin

- Ensure that highly durable 2 TB NFS storage is available to store database archives.
- Ensure that the storage is accessible from the Cisco ONP environment. Set up rules that are defined by the Cisco ONP network and appropriate ACL (Access Control List) to permit or deny access to the storage.

Procedure

- Step 1** Log into the Cisco ONP server, where you have installed Cisco ONP by using the tar archive.

- Step 2** Create a folder for backup. Ideally it should be mounted on a reliable object storage (like NFS).
-

Perform Manual Backup

Perform the following steps for the backup operation:

Procedure

- Step 1** Browse to the location, where the backup_mongo.sh script is stored.

- Step 2** Execute the backup_mongo.sh script using the following command:

Example:

```
user@server:~/cnp_backups$ bash backup_mongo.sh
```

The backup file gets stored in the daily backup folder (backup.daily) with the current time stamp.

Schedule a Backup

Schedule a Backup Using Script

Use this task to schedule the backup operation using script:

Procedure

- Step 1** Log in to the Cisco ONP server.

- Step 2** Execute the rotation.sh script using the following command:

```
user@server:~/cnp_backups$ bash rotation.sh
```

This command creates necessary folder structure.

- Step 3** Execute the setup_backup.sh script using the following command:

Example:

The backup file gets stored in the daily backup folder (backup.daily) with the current time stamp.

- Step 4** Enter the path in the user prompt to store the file.

Backup files are stored in your required file path as following:

```
/user-defined path/backups/backup.daily
```

Schedule a Backup

Use this task to schedule the backup operation using Crontab:

Procedure

- Step 1** Log in to the Cisco ONP server.
- Step 2** Configure the Crontab job using the following command.

```
user@server~/cnp_backups$ sudo crontab -e
```

- Step 3** Modify the Crontab.sh script to schedule the backup.

Example:

The following example shows the scheduling of the backup operation, at 3 a.m daily.

```
0 3 * * * /home/ciscocnp/cnp_backups/backup_mongo.sh
```

Syntax to Schedule the Backup Using Crontab

Use the following syntax to schedule backup in Crontab:

```
m h dom mon dow
```

Where:

- m—Minutes (0–59)
- h—Hours (1–23)
- dom—Day of the month
- mon—Month of the year
- dow—Day of the week

To define the time, you can provide concrete values for minute (m), hour (h), day of the month (dom), month (mon), and day of the week (dow), or use the wildcard, '*' in these fields (for 'any').



Note The backup jobs start based on the cron's system daemon's notion of time and time zones.

Restore Database Manually

Use this task to restore the database manually:

Procedure

- Step 1** Check the Cisco ONP Database.

```
$ mongo CnpDB
```

MongoDB shell version: 2.6.10

```

connecting to: CnpDB
Server has startup warnings:
2019-01-31T12:17:39.354+0000 I STORAGE [initandlisten]
2019-01-31T12:17:39.354+0000 I STORAGE [initandlisten] ** WARNING: Using the XFS filesystem is
strongly recommended with the WiredTiger storage engine.
2019-01-31T12:17:39.354+0000 I STORAGE [initandlisten] ** See
http://dochub.mongodb.org/core/prodnotes-filesystem
2019-01-31T12:17:40.013+0000 I CONTROL [initandlisten]
2019-01-31T12:17:40.013+0000 I CONTROL [initandlisten] ** WARNING: Access control is not enabled
for the database.
2019-01-31T12:17:40.013+0000 I CONTROL [initandlisten] ** Read and write access to data and configuration
is unrestricted.
2019-01-31T12:17:40.013+0000 I CONTROL [initandlisten]
> show collections
NetworkEntity
SystemLog
BOM
fs.files
Users
fs.chunks
ErrorInfo
NetworkObject
UserGroups
TaskInfo
ActionGroups
Roles
>
...

```

Step 2 Remove the Cisco ONP back-end and front-end Docker services,"docker service rm cnp_cnp cnp_cnp_frontend" and check again:

```

...
$ mongo CnpDB
MongoDB shell version: 2.6.10
connecting to: CnpDB
Server has startup warnings:
2019-01-31T12:17:39.354+0000 I STORAGE [initandlisten]

```

```

2019-01-31T12:17:39.354+0000 I STORAGE [initandlisten] ** WARNING: Using the XFS file system is
strongly recommended with the WiredTiger storage engine.
2019-01-31T12:17:39.354+0000 I STORAGE [initandlisten] ** See
http://dochub.mongodb.org/core/prodnotes-filesystem
2019-01-31T12:17:40.013+0000 I CONTROL [initandlisten]
2019-01-31T12:17:40.013+0000 I CONTROL [initandlisten] ** WARNING: Access control is not enabled
for the database.
2019-01-31T12:17:40.013+0000 I CONTROL [initandlisten] ** Read and write access to data and configuration
is unrestricted.
2019-01-31T12:17:40.013+0000 I CONTROL [initandlisten]
> show collections
>
...

```

Step 3 Copy the database to the folder that is mapped to MongoDB container's volume:

```

$ sudo cp backups/2019-02-01-04-29.archive /var/lib/mongodb_cnp/
...

```

Step 4 Restore the database and check.

```

$ docker exec -t cnp_mongo.1.$(docker service ps -f 'name=cnp_mongo.1' -f
'desired-state=running' cnp_mongo -q) bash -c "mongorestore -u \$(cat
\${MONGO_INITDB_ROOT_USERNAME_FILE}) -p \$(cat \${MONGO_INITDB_ROOT_PASSWORD_FILE})
--authenticationDatabase admin --port 27017 -h localhost --db CnpDB --gzip
--archive=/data/db/2019-02-01-04-29.archive"

```

Restore Database Using Script

You can restore the database using script, which is available at the following location:

```
Images/DB_backup/restore_mongo.sh
```

Execute the following command:

```
$ sudo bash restore_mongo.sh DB backup archive file path.
```

For example:

```
$ sudo bash restore_mongo.sh /backups/backup.daily/2019-05-05-23-58.archive
```

Enter `No` to not delete the database and apply only missing data(s) from backup file.



APPENDIX **A**

Cisco ONP UI Reference

- [Menu Bar, on page 127](#)
- [Network Tree, on page 133](#)
- [Design Palette, on page 134](#)
- [Entity Editor, on page 136](#)

Menu Bar

The following table describes the options available in the Cisco ONP GUI menu bar.

Options	Description
File	Includes the common file options such as New, Open, Open Shared, Save, Save As, Share, and Delete
Network	Includes Entity Editor, Analyze, and SSON Convert
Export	Includes options to export reports of CPZ, sites, fibers, SRLGs, services, waves, media channels, optical results, service aggregation, BOM, and messages. Export enables you to download excel and LNI templates
Import	Imports different types of files (CPZ, Excel, LNI, and MPZ) and designs a network in CONP
Manage	Manages Layout Templates and Aliens
Logs	Displays logs events that are initiated during a specific period, such as user login, user logout, password change, and LNI - start, failed, and completed
Job Monitor	Checks and manages tasks running in the background
Control Panel	Manages users, user groups, user roles, permissions, system configuration, and dictionary
Help	Displays the Cisco ONP version
Last Login	Shows last date and time when the user logged in to Cisco ONP, and last login with IP details
Username	Shows name of the user who has currently logged in to Cisco ONP

File

The **File** menu includes common file options such as New, Open, and Delete.

Options	Description
New	Creates a new network. You can check the SSON Network check box and select System Release for NCS 2K to create an SSON network.
Open	Opens a saved network. The network name in blue-colored font indicates that the network is in the Design mode, and the network name in green-colored font indicates that the network is in the Analyze mode. Note If you view a blank screen when you open a network, refresh the browser, or log in to Cisco ONP again.
Open Shared	Opens a shared network.
Save	Saves a network.
Save As	Saves the network with a new name.
Share	Shares a network or networks.
Delete	Deletes a network or networks.

Network

The **Network** menu includes options such as Entity Editor, Analyze, and SSON Convert in the design mode. It includes options such as Entity Editor, Design, Upgrade, and Enter Plan Mode in the Analyze mode.

Options	Description
Entity Editor	Use this option to edit various properties of an element in the network
Analyze	Analyzes the network after completing the design
SSON Convert	Converts a Non-SSON network to an SSON network
Design	Switches from Analyze mode to Design, Upgrade, or Release Upgrade mode
Upgrade	Upgrades an existing network that is in the Analyze mode
Release Upgrade	Upgrades the NCS 2K System Release of a network
Enter Plan Mode	Switches to the Plan mode
Exit Plan Mode	Exits the plan mode
Restore	Restores failed fibers and nodes

Export

The **Export** menu includes options to export reports of Sites, Fibers, Services, SRLG, Waves, Messages, and BOM.

Options	Description
CPZ	Export the .cpz design file of a network into your local system.
Sites	Exports site details such as x and y coordinates, grooming site flag, CLLI code, site address, site type, and site name.
Fibers	Exports fiber details such as length, loss to fiber, source and destination site, source and destination edge.
Services	Exports service details such as name, type, path, quantity, and protection.
SRLGs	Exports details about created SRLGs.
Waves (Available for non-SSON network)	Exports wave details such as Label, Source and Destination sites, Card Type, Wavelength, Utilization, Source port, Destination port, Demands, OTN Hops, OSNR, OSNRMarginEOL, StatusEOL, Excluded Channels, and Path of Wave.
Media Channels (Available for SSON network)	Exports media channel details such as Media Channel Label, Media Carrier Label, Source and Destination sites, Card Type, Wavelength, Utilization, Source port, Destination port, Demands, OTN Hops, OSNR, OSNRMarginEOL, StatusEOL, Excluded Channels, and Path of Media channel.
Messages	Shows the complete log of the analysis, including critical errors.
Excel Template	Download sample Excel file that can be used as a reference for creating networks using the Import Excel feature.
LNI Template	Download sample LNI file that can be used as a reference for creating networks using the Import feature.
BOMs	Exports details about pricing and quantity of the network equipment
Failure Groups	This option is available only in the plan mode. You can add failed fibers to a failure group.
Failure Report	This option is available only in the plan mode. It shows the failed fibers, total channels, failed channels, restored channels, and fiber hotzones.
Optical Result	Exports details such as protection type, SOL, EOL, source, and destination

Import

The Import menu imports an Excel file, a CPZ file, or an MPZ file.

Options	Description
CPZ	Imports the .cpz network design files that are exported from another Cisco ONP instance
Excel	Imports an Excel file containing all the design parameters
Live	Imports a live deployed network by retrieving configurations of the nodes, provided in the LNI input Excel sheet
MPZ	Imports the .mpz network design files from CTP to Cisco ONP, to avoid recreating the networks that are already created in CTP

Manage

You can manage layout templates and aliens.

Options	Description
Layout Templates	Imports reusable templates to design layout configurations for a network
Aliens	Imports an alien or aliens from your local system

Logs

The System Logs option allows an admin user, or user with USER MANAGEMENT, and NETWORK MANAGEMENT permissions to view at logs the events that are initiated during a specific time interval. Examples of events are user login, user logout, password change, Live Network Import (LNI)-start, failed, completed and analysis-start, and failed.

The **SYSTEM LOGS** page includes the following fields:

Field	Description
Time Stamp	Provides the date and time of the specific event
Event Type	Shows the type of event, which includes user login, user logout, password change, and so on
Description	Describes the event, which includes user login success, user logout success, and so on
Username	Shows the user who has initiated specific events
Event Source	Shows the IP address of the device from where the event is initiated

Events that are captured in the System Logs are:

Event	Description
SIGNUP	New user sign-up for Cisco ONP
LOGIN	User log in to Cisco ONP

Event	Description
USER STATE CHANGE	User state change from Active to Inactive and the converse
USER ROLE CHANGE	User role change, such as admin to planner, and so on
LOGOUT	User log out from Cisco ONP
USER DELETION	Deletion of a particular user
UNAUTHORIZED	User enters invalid login credentials
LNI_START	Successful initiation of Live Network Import
LNI_COMPLETE	Successful completion of live import of a network
LNI_CANCEL	Cancellation of Live Network Import
LNI_PURGE	Imported Live network data is successfully purged
ANALYZE_LNI_START	Analysis of LNI network started successfully
ANALYZE_LNI_END	Analysis of LNI network completed successfully
LNI_POPULATE_DESIGN_DATA	Populating of L0 DesignData initiated
ANALYZE START	Starting of the network analysis
ANALYZE END	Completion of the network analysis
ANALYZE CANCEL	Cancellation of the network analysis
UPGRADE NETWORK	Entering the Upgrade mode
PLAN_INIT	Entering the Plan mode
PLAN_END	Exiting the Plan mode
PLAN_REROUTE	Checking for alternate paths to restore failed media channels or waves
PLAN_PROGRESS	Restoration of failed media channels or waves in progress
RELEASE_UPGRADE_NETWORK	Upgrading the system release of the network is in progress.

Job Monitor

The **Job Monitor** menu checks and manages tasks running in the background.

You can access this menu if you have ADMIN, NETWORK_MANAGEMENT, or NETWORK_PLANNING role.

The **JOB MONITOR** page has the following options:

Options	Description
Refresh	Refreshes the display information.

Options	Description
Filter	Applies one or more of the following filter options: Task Type: Filters the display information based on the task type. Select Start Date: Filters the display information based on the start date of the task. Select End Date: Filters the display information based on the end date of the task. Username: Filters the display information based on the username.
Created Date	The date on which the task is started by the user.
Network Name	Name of the network on which the task is running.
Task Type	The type of background task: Valid values are ANALYZE and EPNM_IMPORT.
Messages	The current state of the task.
Cancel	Enables you to cancel or stop an ongoing background task: <ul style="list-style-type: none"> • The Admin can cancel any of the running background tasks. Other valid users can cancel only their own tasks. • If you want to cancel your ongoing network analysis, you can open Cisco ONP at the browser in incognito mode, or contact the Admin. • After a task is cancelled, it gets removed from the job monitor. You can check the status of a cancelled task from System logs page. Click Logs to open the System logs page.
Check Progress	Enables you to view the status of the LNI operation.

Control Panel

Apart from designing, analyzing, and creating BOM for a network, a user with admin rights can activate, manage, and delete users and their roles.

To navigate to the control panel page, click **Control Panel**.

The admin or any user with USER_MANAGEMENT role can lock, unlock an individual user account, and manually expire the individual user password. For more information, see [Manage Users and Roles](#), on page 9.

Help

This menu provides information about the Cisco ONP version.

Field	Description
About	Provides the Cisco ONP version.

Network Tree

The left pane of the Cisco ONP home page comprises a network tree. The network tree includes various network elements. When you click each element, the respective property is displayed under the network tree. You can edit the properties. For more information on editing the network properties, see [Modify Network Properties, on page 69](#).

Table 26: Network Tree Elements

Network Tree Elements	Description
Network name	Displays the name of the network.
Sites	Customer premise equipment that is located in a rack within a building.
Fiber	Optical fiber connecting two sites.
Fiber Couple	A fiber couple consists of two different fibers (clockwise and counterclockwise), one for transmission and another for reception.
Services	Service is the circuit through which traffic flows between nodes. When you add services to the Traffic site (of the type 1K-2K-4K) in an SSON network, a DefaultGroup is created under the Services in the network tree. You can also create a new service group.
Waves or Medial Channel	The wave or Media channel represents a DWDM channel. In a wave hierarchy, for each wave, there is a trail. When you expand a trail, there is a section under each trail. The trail is an optical path or a network section joining two traffic nodes. It can have more than one section depending on whether the trail has a regenerator site. For more information on regeneration, see Regeneration Support, on page 105 .
SRLG	Shared Risk Link Group (SRLG) is useful for routing the protected services. If there are Fiber 1 and Fiber 2 in the network, they are assumed to be diverse and are used as alternates for protection purposes. If Fiber 1 and Fiber 2 are in an SRLG, they are not true alternates, and they share the same risk of failure. Therefore, if Fiber1 fails, Fiber 2 also fails, and Fiber 2 cannot be used as a protected path.

Network Tree Elements	Description
Optical subnet	An optical subnet is a collection of spans with certain associated properties. When you create a new network, Cisco ONP automatically creates an optical subnet that is associated to the network. At least one optical subnet must exist for each network.
Stage button	Visible only in the Analyze mode.

Use the Search box on top of the network tree to search for any specific site, fiber, or wave in the network tree panel. Click the Refresh icon to refresh your search.

Design Palette

Table 27: Feature History

Feature Name	Release Information	Feature Description
Intuitive Map Display	Cisco ONP Release 5.2	<p>The new intuitive map display allows you to virtually rearrange networks for a clutter-free view without impacting the original design. This display simplifies adding new nodes to complex networks. Save the last modified network in the new view to retain the latest rearrangement. The new icons in the Design Palette that enable the intuitive display are:</p> <ul style="list-style-type: none"> • Switch to Intuitive Arrangement/Switch to Coordinates Arrangement—Toggles the map between the intuitive and original displays. • Rearrange nodes—Overrides node coordinates and rearranges the map in a presentable manner.

At the right of the Cisco ONP home page, there is the design palette. You can use this design palette to create a network design. It consists of the following six icons:

Icons	Description
Zoom In	Click this icon to magnify the map.
Zoom Out	Click this icon to minimize the map.
Reset Zoom	Click this icon to reset the map to its original size.

Icons	Description
Drawing Tool	<p>The Drawing Tool consists of the following icons:</p> <ul style="list-style-type: none"> • Traffic Site: Select this icon, and click the working area to create traffic sites in the network. • ROADM Site: Select this icon, and click the working area to create ROADM sites. • OLA Site: Select this icon, and click the working area to create OLA sites. • Passthrough Site: Select this icon, and click the working area to create passthrough sites. • Link: Click this icon, and drag and drop between sites to create a fiber link. • OTN Service: Click this icon to create OTN service between sites. • DWDM channel: Click this icon to add a wave or medial channel between sites. • Select: The Select icon looks similar to the cursor tool. Click this icon to select a node, link service, and so on.
Layers Window	<p>Use this icon to view or hide layers such as fiber link, service, text, and channel. The following are the four toggle icons:</p> <ul style="list-style-type: none"> • Toggle Fiber: Click this icon to view or hide fiber link details from the network. • Toggle Service: Click this icon to view or hide service details from the network. • Toggle Wave: Click this icon to view or hide the channel or wave details from the network. • Toggle Text: Click this icon to view or hide the text from the network. • Toggle SVO associations: Click this icon to remove or add SVO associations. • Expand/Collapse All Demands: Click this icon to expand the waves or media channels so that you can view them clearly. Click this icon again to collapse the waves and media channels to their original shape and position. <p>The eye symbol in the icon indicates that you are currently viewing the respective details.</p>
Zoom Tool	<p>The icon below the Drawing Tool is the Zoom Tool. You can change the display of the working area by using this function. Click the arrow to view two sliders.</p> <ul style="list-style-type: none"> • Map Fade: Move the Map Fade slider from right to left to fade the map from the background. • Zoom In/Out: To magnify the map, move the Zoom in or out slider from left to right.

Icons	Description
Zoom Elements	Click the Zoom Elements icon to view four sliders. <ul style="list-style-type: none"> • Media Channel Width: Move this slider from left to right to increase the channel width. • Path Spread: Move this slider from left to right to increase the space between the paths. • Fiber Width: Move this slider from left to right to increase the fiber width. • Service Width: Move this slider from left to right to increase the service width.
Show Failed (available only in plan mode)	This icon shows the failed media channels in the map. Failed ones are marked with a red cross mark.
Traffic Monitor (available only in plan mode)	This icon shows the total number of impacted media channels, demands, or services that are working or failed in the entire network.

Entity Editor

The **Entity Editor** allows you to edit various properties of an element in the network. Choose **Network > Entity Editor** to open the **Entity Editor** window. The following table explains the operations that you can perform in the **Entity Editor** window.

Options	Description
Left pane filter	Includes check boxes to filter the network elements displayed under each tab: <ul style="list-style-type: none"> • For the SITE tab, you can choose whether to display OTN (only traffic node), DWDM (ROADM, OLA, or pass-through) node, or both. • For the FIBER tab, you can choose the fiber connecting a particular source and destination sites. • For the SERVICE tab, you can choose to display either services, waves, or both.
Right pane properties	Displays all properties of the selected network element. You can modify the properties as required.
Search	Searches for a particular network element.
Refresh	Refreshes the network elements that are listed under each tab.

Options	Description
Expand/Collapse	Expands or collapses the network elements available in the network tree under each tab.
Select Similar	<p>Use this option to make a similar selection. For example, select a ROADM site, and click the Select Similar icon. All ROADM sites get selected.</p> <p>You can change a property in all the selected sites at one time.</p> <p>Allows you to identify and compare the property difference. For example, if a property is different among the selected sites, that property is dimmed. You can select an option that is applied to all the selections.</p>
Un-Select All	Deselects all selections that you make under the network tree.
Delete	Deletes the selected network elements.
Add Contentionless Sides (available only under the SITE tab)	<p>Contentionless functionality on a site refers to the contentionless add/drop ability of an N-degree ROADM node to accommodate N wavelengths of the same frequency from a single add/drop device. For a ROADM to be contentionless, the number of drop units have to be equal to ROADM degrees.</p> <ul style="list-style-type: none"> • Click the ROADM site to which you want to add contentionless sides. • Click the Add Contentionless Side icon. • Enter the appropriate value in the Enter number of contentionless sides field. • Click OK. <p>After adding the contentionless side, you can edit the contentionless port property of the side at the right pane. You can select any of the values ranging from 1 to 16. The default value is 16.</p>

Options	Description
Copy (available only under the SERVICE tab)	<p>Use this option to clone a service or wave that is connected between two sites.</p> <ul style="list-style-type: none">• Select a wave and click Copy.• Enter the quantity in the Clone Service/DWDM Channel dialog box, and click OK. <p>The label of the new wave has –1 appended to the label of the cloned wave. For example, Site-2-Site3-1-1 is the label of the new wave that is created by cloning the wave Site-2-Site3-1. You can rename the label.</p> <p>You can also clone a service in a similar way.</p>



APPENDIX B

Supported Cards and Pluggables

- [Supported Transponder Cards and Pluggables, on page 139](#)

Supported Transponder Cards and Pluggables

Table 28: Feature History

Feature Name	Release Information	Feature Description
Pluggable Support	Cisco ONP Release 4.1	QSFP-100G-FR-S= pluggable is supported on the QSFP ports of the 400G-XP LC transponder card with 100GE data rate.

Cisco ONP supports the following transponders and pluggable:

Transponder/ Muxponder	Traffic Type	FEC mode	Pluggables Supported	Encryption SSON	Encryption Non-SSON	Trunk Mode
200G-CK-LC + MR-MXP (200G MXP mode)	<ul style="list-style-type: none"> • 100GE • OTU4 	SD-FEC_20	<ul style="list-style-type: none"> • SR-1(CPAK-100G-SR10) • SR-1(CPAK-100G-SR4) • LR-1(CPAK-100G-LR4) • SR-1(CPAK-100G-SR10) • LR-1(CPAK-100G-LR4) 	Yes (only for 100GE)	No	Auto, TRK_200G
200G-CK-LC + MR-MXP (100G TXP mode)	100GE	SD-FEC_20	<ul style="list-style-type: none"> • SR-1(CPAK-100G-SR10) • SR-1(CPAK-100G-SR4) • LR-1(CPAK-100G-LR4) 	Yes	Yes	Auto, TRK_100G
200G-CK-LC + MR-MXP (100G TXP mode)	100GE	SD-EFEC	<ul style="list-style-type: none"> • SR-1(CPAK-100G-SR10) • SR-1(CPAK-100G-SR4) • LR-1(CPAK-100G-LR4) 	Yes	Yes	Auto, TRK_100G

Transponder/Muxponder	Traffic Type	FEC mode	Pluggables Supported	Encryption SSON	Encryption Non-SSON	Trunk Mode
200G-CK-LC + MR-MXP (100G TXP mode)	100GE	SD-FEC	<ul style="list-style-type: none"> • SR-1(CPAK-100G-SR10) • SR-1(CPAK-100G-SR4) • LR-1(CPAK-100G-LR4) 	Yes	Yes	Auto, TRK_100G
200G-CK-LC + MR-MXP (100G MXP mode)	<ul style="list-style-type: none"> • 10GE • 10GE LAN PHY • OC192 • OTU2 	SD-FEC_20	<ul style="list-style-type: none"> • LR-1(ONS-QSFP-4*10G-MLR) • LR-1(QSFP-4*10G-MLR) • SR-1(QSFP-40G-SR4) • SR-1(ONS-SC+10G-SR) • LR-1(ONS-SC+10G-LR) • DWDM(ONS-SC+-10G-C) • DWDM(ONS-SC+-10GEP:xxx) 	Yes	Yes	Auto, TRK_100G
200G-CK-LC + MR-MXP (100G MXP mode)	<ul style="list-style-type: none"> • 10GE • 10GE LAN PHY • OC192 • OTU2 	SD-EFEC	<ul style="list-style-type: none"> • LR-1(ONS-QSFP-4*10G-MLR) • LR-1(QSFP-4*10G-MLR) • SR-1(QSFP-40G-SR4) • SR-1(ONS-SC+10G-SR) • LR-1(ONS-SC+10G-LR) • DWDM(ONS-SC+-10G-C) • DWDM(ONS-SC+-10GEP:xxx) 	Yes	Yes	Auto, TRK_100G
200G-CK-LC + MR-MXP (100G MXP mode)	<ul style="list-style-type: none"> • 10GE LAN PHY • 10GE • OC192 • OTU2 	SD-FEC	<ul style="list-style-type: none"> • LR-1(ONS-QSFP-4*10G-MLR) • LR-1(QSFP-4*10G-MLR) • SR-1(QSFP-40G-SR4) • SR-1(ONS-SC+10G-SR) • LR-1(ONS-SC+10G-LR) • DWDM(ONS-SC+-10G-C) • DWDM(ONS-SC+-10GEP:xxx) 	Yes	Yes	Auto, TRK_100G

Transponder/ Muxponder	Traffic Type	FEC mode	Pluggables Supported	Encryption SSON	Encryption Non-SSON	Trunk Mode
200G-CK-LC + MR-MXP (100G MXP mode 2*10G 2*40G MODE)	<ul style="list-style-type: none"> • 10GE • 10GE LAN PHY • 40GE 	SD-FEC_20	<ul style="list-style-type: none"> • SR-1(ONS-SC+10G-SR) • LR-1(ONS-SC+10G-LR) • DWDM(ONS-SC+-10G-C) • LR-1(QSFP-40G-LR4) • DWDM(ONS-SC+-10GEPxxx) • SR-1(QSFP-40G-SR4) • SR-1(QSFP-40G-SR-BD) 	Yes	Yes	Auto, TRK_100G
200G - CK-LC + MR - MXP (100G MXP mode 2*10G 2*40G MODE)	<ul style="list-style-type: none"> • 10GE • 40GE 	SD-EFEC	<ul style="list-style-type: none"> • SR-1(ONS-SC+10G-SR) • LR-1(ONS-SC+10G-LR) • DWDM(ONS-SC+-10G-C) • DWDM(ONS-SC+-10GEPxxx) • SR-1(QSFP-40G-SR4) • LR-1(QSFP-40G-LR4) • SR-1(QSFP-40G-SR-BD) 	Yes	Yes	Auto, TRK_100G
200G - CK-LC + MR -MXP (100G MXP mode 2*10G 2*40G MODE)	<ul style="list-style-type: none"> • 10GE • 40GE 	SD-FEC	<ul style="list-style-type: none"> • SR-1(ONS-SC+10G-SR) • LR-1(ONS-SC+10G-LR) • DWDM(ONS-SC+-10G-C) • DWDM(ONS-SC+-10GEPxxx) • SR-1(QSFP-40G-SR4) • LR-1(QSFP-40G-LR4) • SR-1(QSFP-40G-SR-BD) 	Yes	Yes	Auto, TRK_100G
200G - CK-LC +10x10G -LC	<ul style="list-style-type: none"> • 10GE • OC192 • OTU2 • OTU2e 	SD- FEC_20	<ul style="list-style-type: none"> • SR-1(ONS-SC+-10G-SR) • LR-1(ONS-SC+-10G-LR) • DWDM(ONS-SC+-10G-C) • DWDM(ONS-SC+-10GEPxxx) • ER(ONS-SC+-10G-ER) • ZR (ONS-SC+-10G-ZR) • DWDM(ONS-SC+-10G-xx.x) 	Yes for OTU2e	No	Auto, TRK_100G

Transponder/ Muxponder	Traffic Type	FEC mode	Pluggables Supported	Encryption SSON	Encryption Non-SSON	Trunk Mode
200G - CK-LC +10x10G -LC	<ul style="list-style-type: none"> • 10GE • OC192 • OTU2 • OTU2e 	SD-EFEC	<ul style="list-style-type: none"> • SR-1(ONS-SC+-10G-SR) • LR-1(ONS-SC+-10G-LR) • DWDM(ONS-SC+-10G-C) • DWDM(ONS-SC+-10GEPxxx) • ER (ONS-SC+-10G-ER) • ZR (ONS-SC+-10G-ZR) • DWDM(ONS-SC+-10G-xxx) 	Yes for OTU2e	No	Auto, TRK_100G
200G-CK-LC + 10x10G -LC	<ul style="list-style-type: none"> • 10GE • OC192 • OTU2 • OTU2e 	SD-FEC	<ul style="list-style-type: none"> • SR-1(ONS-SC+-10G-SR) • LR-1(ONS-SC+-10G-LR) • DWDM(ONS-SC+-10G-C) • DWDM(ONS-SC+-10GEPxxx) • ER(ONS-SC+-10G-ER) • ZR(ONS-SC+-10G-ZR) • DWDM(ONS-SC+-10G-xxx) 	Yes for OTU2e	No	Auto, TRK_100G
200G - CK-LC + MR-MXP (200G Mxp 100G+10*10G Mode)	<ul style="list-style-type: none"> • 100GE • 10GE • OC192 • OTU2 	SD- FEC_20	<ul style="list-style-type: none"> • SR-1(CPAK-100G-SR10) • SR-1(CPAK-100G-SR4) • LR-1(CPAK-100G-LR4) • SR-1(ONS-SC+-10G-SR) • LR-1(ONS-SC+-10G-LR) • DWDM(ONS-SC+-10G-C) • DWDM(ONS-SC+-10GEPxxx) • ER(ONS-SC+-10G-ER) • ZR(ONS-SC+-10G-ZR) • DWDM(ONS-SC+-10G-xxx) 	Yes for 100GE and OTU2	No	Auto, TRK_200G

Transponder/ Muxponder	Traffic Type	FEC mode	Pluggables Supported	Encryption SSON	Encryption Non-SSON	Trunk Mode
200G-CK-LC + MR-MXP + MR-MXP (200G Mxp 4*40G + 4*10G Mode)	<ul style="list-style-type: none"> • 10GE • 10GE LAN PHY • 40GE 	SD- FEC_20	<ul style="list-style-type: none"> • SR-1(ONS-SC+-10G-SR) • LR-1(ONS-SC+-10G-LR) • DWDM(ONS-SC+-10G-C) • DWDM(ONS-SC+-10GEPxxx) • SR-1(QSFP-40G-SR4) • LR-1(QSFP-40G-LR4) • SR-1(QSFP-40G-SR-BD) 	Yes	Yes	Auto, TRK_200G
200G-CK-LC + 10x10G -LC + MR-MXP	<ul style="list-style-type: none"> • 10GE • OC192 • OTU2 	SD- FEC_20	<ul style="list-style-type: none"> • SR-1(ONS-SC+-10G-SR) • LR-1(ONS-SC+-10G-LR) • DWDM(ONS-SC+-10G-C) • DWDM(ONS-SC+-10GEPxxx) • ER(ONS-SC+-10G-ER) • ZR(ONS-SC+-10G-ZR) • DWDM(ONS-SC+-10G-xx.x) • LR-1(ONS-QSFP4*10G-MLR) • ZR(ONS-SC+-10G-ZR) 	Yes	Yes	Auto, TRK_200G
200G-CK-LC + MR-MXP + MR-MXP	<ul style="list-style-type: none"> • 10GE • OC192 • OTU2 	SD-FEC_20	<ul style="list-style-type: none"> • SR-1(ONS-SC+-10G-SR) • LR-1(ONS-SC+-10G-LR) • DWDM(ONS-SC+-10G-C) • DWDM(ONS-SC+-10GEPxxx) • ER(ONS-SC+-10G-ER) • ZR(ONS-SC+-10G-ZR) • DWDM(ONS-SC+-10G-xx.x) • LR-1(ONS-QSFP4*10G-MLR) • ZR(ONS-SC+-10G-ZR) 	Yes	Yes	Auto, TRK_200G

Transponder/ Muxponder	Traffic Type	FEC mode	Pluggables Supported	Encryption SSON	Encryption Non-SSON	Trunk Mode
100GS - CK-LC + 10x10G-LC	<ul style="list-style-type: none"> • 10GE • OC192 	EFEC, SD-FEC_20	<ul style="list-style-type: none"> • SR-1(ONS-SC+-10G-SR) • LR-1(ONS-SC+-10G-LR) • DWDM(ONS-SC+-10G-C) • DWDM(ONS-SC+-10GEPxxx) • ER(ONS-SC+-10G-ER) • ZR(ONS-SC+-10G-ZR) • DWDM(ONS-SC+-10G-xxx) 	No	No	Auto, TRK_100G
100G - LC-C + 10x10G-LC	<ul style="list-style-type: none"> • 10GE • OC192 • Fiber Channel 10G • Fiber Channel 8G • OTU2 • OTU2e 	FEC	<ul style="list-style-type: none"> • SR-1(ONS-SC+-10G-SR) • LR-1(ONS-SC+-10G-LR) • DWDM(ONS-SC+-10G-C) • DWDM(ONS-SC+-10GEPxxx) • ER(ONS-SC+-10G-ER) • ZR(ONS-SC+-10G-ZR) • DWDM(ONS-SC+-10G-xxx) 	No	No	Auto
100G - LC-C + 10x10G-LC	<ul style="list-style-type: none"> • 10GE • OC192 • Fiber Channel 10G • Fiber Channel 8G • OTU2 • OTU2e 	EFEC	<ul style="list-style-type: none"> • SR-1(ONS-SC+-10G-SR) • LR-1(ONS-SC+-10G-LR) • DWDM(ONS-SC+-10G-C) • DWDM(ONS-SC+-10GEPxxx) • ER (ONS-SC+-10G-ER) • ZR(ONS-SC+-10G-ZR) • DWDM(ONS-SC+-10G-xxx) 	No	No	Auto

Transponder/ Muxponder	Traffic Type	FEC mode	Pluggables Supported	Encryption SSON	Encryption Non-SSON	Trunk Mode
100G - LC-C + 10x10G-LC	<ul style="list-style-type: none"> • 10GE • OC192 • Fiber Channel 10G • Fiber Channel 8G • OTU2 • OTU2e 	HG-FEC	<ul style="list-style-type: none"> • SR-1(ONS-SC+-10G-SR) • LR-1(ONS-SC+-10G-LR) • DWDM(ONS-SC+-10G-C) • DWDM(ONS-SC+-10GEPxxx) • ER (ONS-SC+-10G-ER) • ZR (ONS-SC+-10G-ZR) • DWDM(ONS-SC+-10G-xx.x) 	No	No	Auto
100G - CK- LC-C + 10x10G-LC	<ul style="list-style-type: none"> • 10GE • 10GE LAN PHY • OC192 • Fiber Channel 10G • Fiber Channel 8G • OTU2 • OTU2e 	FEC	<ul style="list-style-type: none"> • SR-1(ONS-SC+-10G-SR) • LR-1(ONS-SC+-10G-LR) • DWDM(ONS-SC+-10G-C) • DWDM(ONS-SC+-10GEPxxx) • ER(ONS-SC+-10G-ER) • ZR(ONS-SC+-10G-ZR) • DWDM(ONS-SC+-10G-xx.x) 	No	No	Auto

Transponder/Muxponder	Traffic Type	FEC mode	Pluggables Supported	Encryption SSON	Encryption Non-SSON	Trunk Mode
100G -CK-LC-C + 10x10G-LC	<ul style="list-style-type: none"> • 10GE • 10GE LAN PHY • OC192 • Fiber Channel 10G • Fiber Channel 8G • OTU2 • OTU2e 	EFEC	<ul style="list-style-type: none"> • SR-1(ONS-SC+-10G-SR) • LR-1(ONS-SC+-10G-LR) • DWDM(ONS-SC+-10G-C) • DWDM(ONS-SC+-10GEPxxx) • ER(ONS-SC+-10G-ER) • ZR(ONS-SC+-10G-ZR) • DWDM(ONS-SC+-10G-xxx) 	No	No	Auto
100G - CK-LC-C + 10x10G-LC	<ul style="list-style-type: none"> • 10GE • 10GE LAN PHY • OC192 • Fiber Channel 10G • Fiber Channel 8G • OTU2 • OTU2e 	HG-FEC	<ul style="list-style-type: none"> • SR-1(ONS-SC+-10G-SR) • LR-1(ONS-SC+-10G-LR) • DWDM(ONS-SC+-10G-C) • DWDM(ONS-SC+-10GEPxxx) • ER(ONS-SC+-10G-ER) • ZR(ONS-SC+-10G-ZR) • DWDM(ONS-SC+-10G-xxx) 	No	No	Auto

Transponder/ Muxponder	Traffic Type	FEC mode	Pluggables Supported	Encryption SSON	Encryption Non-SSON	Trunk Mode
400G-XP-LC	<ul style="list-style-type: none"> • 100GE • 10GE LAN PHY • 10GE • 40GE • Fiber Channel 10G • Fiber Channel 16G • Fiber Channel 8G • OC192 /STM64 • OTU2 • OTU2e • OTU4 	SD-FEC_25- NO_DE	<ul style="list-style-type: none"> • SR-1(QSFP-100G-SR4-S) • LR-1(QSFP-100G-LR4-S) • LR-1(QSFP-28-LR4) • SR-1(QSFP-100G-SM-SR) • SR-1(QSFP-40/100G-SRBD) • LR-1(ONS-QSFP-4*10G-MLR) • LR-1(QSFP-4*10G-LR) • SR-1(QSFP-40G-SR4) • ER(ONS-QSFP-4*10G-MER) • LR-1(QSFP-40G-LR4) • SR-1(QSFP-40G-SR-BD) • LR-1(ONS-QC16GFC-LW) • LR-1(ONS-QC16GFC-SW) • LR-1(ONS-QSFP28-LR4) • FR-1 (QSFP-100G-FR-S) (only for 100GE) 	Yes	Yes	TRK_100G, TRK_200G

Transponder/ Muxponder	Traffic Type	FEC mode	Pluggables Supported	Encryption SSON	Encryption Non-SSON	Trunk Mode
400G-XP-LC	<ul style="list-style-type: none"> • 100GE • 10GE LAN PHY • 10GE • 40GE • Fiber Channel 10G • Fiber Channel 16G • Fiber Channel 8G • OC192 /STM64 • OTU2 • OTU2e • OTU4 	SD-FEC_15-NO_DE	<ul style="list-style-type: none"> • SR-1(QSFP-100G-SR4-S) • LR-1(QSFP-100G-LR4-S) • LR-1(QSFP-28-LR4) • SR-1(QSFP-100G-SM-SR) • SR-1 (QSFP-40/100G-SRBD) • LR-1(ONS-QSFP-4*10G-MLR) • LR-1(QSFP-4*10G-LR) • SR-1(QSFP-40G-SR4) • ER(ONS-QSFP-4*10G-MER) • LR-1(QSFP-40G-LR4) • SR-1(QSFP-40G-SR-BD) • LR-1(ONS-QC16GFC-LW) • LR-1(ONS-QC16GFC-SW) • LR-1(ONS-QSFP28-LR4) • FR-1 (QSFP-100G-FR-S) (only for 100GE) 	Yes	Yes	TRK_100G, TRK_200G
100G-LC-C	<ul style="list-style-type: none"> • 100GE • OTU4 	FEC	SR-1(CPAK-100G-SR10)	No	No	Auto
100G-LC-C	<ul style="list-style-type: none"> • 100GE • OTU4 	EFEC	SR-1(CPAK-100G-SR10)	No	No	Auto
100G-LC-C	<ul style="list-style-type: none"> • 100GE • OTU4 	HGFEC	SR-1(CPAK-100G-SR10)	No	No	Auto
100G - CK-LC-C	<ul style="list-style-type: none"> • 100GE • 40GE • OTU4 	FEC	<ul style="list-style-type: none"> • SR-1(CPAK-100G-SR4) • SR-1(CPAK-100G-SR10) • LR-1(CPAK-100G-LR4) 	No	No	Auto

Transponder/ Muxponder	Traffic Type	FEC mode	Pluggables Supported	Encryption SSON	Encryption Non-SSON	Trunk Mode
100G - CK-LC-C	<ul style="list-style-type: none"> • 100GE • 40GE • OTU4 	EFEC	<ul style="list-style-type: none"> • SR-1(CPAK-100G-SR4) • SR-1(CPAK-100G-SR10) • LR-1(CPAK-100G-LR4) 	No	No	Auto
100G - CK-LC-C	<ul style="list-style-type: none"> • 100GE • 40GE • OTU4 	HGFEC	<ul style="list-style-type: none"> • SR-1(CPAK-100G-SR4) • SR-1(CPAK-100G-SR10) • LR-1(CPAK-100G-LR4) 	No	No	Auto
100GS - CK-LC	100GE	FEC	SR-1(CPAK-100G-SR10)	Yes	No	Auto, TRK_100G
100GS - CK-LC	100GE	EFEC	LR-1(CPAK-100G-LR4)	Yes	No	Auto, TRK_100G
100GS - CK-LC	100GE	SD-FEC_20	SR-1(CPAK-100G-SR10)	Yes	No	Auto, TRK_100G
200G - CK-LC (100G Mode only)	<ul style="list-style-type: none"> • 100GE • OTU4 	FEC	<ul style="list-style-type: none"> • SR-1(CPAK-100G-SR4) • SR-1(CPAK-100G-SR10) • LR-1(CPAK-100G-LR4) 	Yes (for 100GE)	No	Auto, TRK_100G
200G - CK-LC (100G Mode only)	<ul style="list-style-type: none"> • 100GE • OTU4 	EFEC	<ul style="list-style-type: none"> • SR-1(CPAK-100G-SR4) • SR-1(CPAK-100G-SR10) • LR-1(CPAK-100G-LR4) 	Yes (for 100GE)	No	Auto, TRK_100G
200G-CK-LC (100G Mode only)	<ul style="list-style-type: none"> • 100GE • OTU4 	SD-FEC_20	<ul style="list-style-type: none"> • SR-1(CPAK-100G-SR4) • SR-1(CPAK-100G-SR10) • LR-1(CPAK-100G-LR4) 	Yes (for 100GE)	No	Auto, TRK_100G



APPENDIX **C**

Supported Aliens

- [Supported Aliens, on page 151](#)

Supported Aliens

Cisco ONP supports the following aliens:

- Aliens_400GXP_NCS4K DWDM Line Card
 - 400GXP_100G_25%_DE
 - 400GXP_200G_15%_DE
 - 100G-SD-FEC
 - 400GXP_100G_15%_DE
 - 200G-SD-FEC
 - 400GXP_100G_15%
 - 400GXP_200G_15%
 - 400GXP_200G_25%DE
- NCS1004_Aliens_V2
 - NCS1004_QPSK_SP_16QAM_200G_27%SDFEC_60GBd
 - NCS1004_SP_16QAM_300G_27%SDFEC_69GBd
 - NCS1004_QPSK_200G_27%SDFEC_69GBd
 - NCS1004_16QAM_32QAM_400G_27%SDFEC_62GBd
 - NCS1004_16QAM_400G_27%SDFEC_69GBd
 - NCS1004_SP_16QAM_16QAM_300G_27%SDFEC_60GBd
 - NCS1004_32QAM_500G_27%SDFEC_69GBd



Note NCS 1004 is supported as an alien.



Note The following aliens are not supported in NCS 2000 Release 11.0:

- NCS1004_16QAM_32QAM_400G_27%SDFEC_62GBd
- NCS1004_QPSK_SP_16QAM_200G_27%SDFEC_60GB

Hence, we recommend you to upgrade the system release of the network to Release 11.1, or force the aliens that are supported for the Release 11.0.



APPENDIX **D**

Supported Amplifiers

- [Supported Amplifiers, on page 153](#)

Supported Amplifiers

Cisco ONP supports the following amplifiers:

Table 29: Cisco ONP Supported NCS 2000 Amplifiers

Amplifier	Description
15454-M-RAMAN-CTP	Raman Amp C-Band
15454-M-RAMAN-COP	Raman Amp C-Band
EDFA 35 for OLA node	Erbium Doped Fiber Amplifier (EDFA) that can function in dual gain with maximum gain of 35 dB
NCS2K-EDRA2-26C	21dBm EDFA + Bst 26dB Span - C-Band
NCS2K-EDRA1-26C	21dBm EDFA 26dB Span - C-Band
NCS2K-EDRA2-35C	21dBm EDFA + Bst 35dB Span - C-Band
NCS2K-EDRA1-35C	21dBm EDFA 35dB Span - C-Band



Note

- RAMAN-CTP is supported on all nodes.
- EDRA's are supported on the OLA node.
- For ROADM and Traffic nodes, the booster amplifier and preamplifier are in-built. The booster is 20SMR-FS-BST.

