



# Performance Monitoring



**Note**

The terms "Unidirectional Path Switched Ring" and "UPSR" may appear in Cisco literature. These terms do not refer to using Cisco ONS 15xxx products in a unidirectional path switched ring configuration. Rather, these terms, as well as "Path Protected Mesh Network" and "PPMN," refer generally to Cisco's path protection feature, which may be used in any topological network configuration. Cisco does not recommend using its path protection feature in any particular topological network configuration.

This chapter defines PM parameters and concepts for Cisco ONS 15600 SDH optical cards. You can use performance monitoring (PM) parameters to gather, store, threshold, and report performance data for early detection of problems.



**Note**

For additional information regarding PM parameters, refer to ITU-T G.826, G.827, G.828, G.829, M2101, and M2102, or Telcordia documents GR-1230-CORE, GR-820-CORE, GR-499-CORE, and GR-253-CORE and the ANSI T1.231 document entitled *Digital Hierarchy - Layer 1 In-Service Digital Transmission Performance Monitoring*.

For information about enabling and viewing PM values, refer to the *Cisco ONS 15600 SDH Procedure Guide*.

Chapter topics include:

- [12.1 Threshold Performance Monitoring, page 12-1](#)
- [12.2 Intermediate-Path Performance Monitoring, page 12-2](#)
- [12.3 Pointer Justification Count, page 12-2](#)
- [12.4 Performance-Monitoring Parameter Definitions, page 12-3](#)
- [12.5 Optical Card Performance Monitoring, page 12-5](#)
- [12.6 ASAP Card Performance Monitoring, page 12-7](#)

## 12.1 Threshold Performance Monitoring

Thresholds are used to set error levels for each PM. You can program PM threshold ranges from the Provisioning > SDH Thresholds tabs on the Cisco Transport Controller (CTC) card view. To provision card thresholds, such as line, path, and SDH thresholds, refer to the *Cisco ONS 15600 SDH Procedure Guide*.

During the accumulation cycle, if the current value of a performance monitoring parameter reaches or exceeds its corresponding threshold value, a threshold crossing alert (TCA) is generated by the node and sent to CTC. TCAs provide early detection of performance degradation. When a threshold is crossed, the node continues to count the errors during a given accumulation period. If 0 is entered as the threshold value, the performance monitoring parameter is disabled.

Change the threshold if the default value does not satisfy your error monitoring needs. For example, customers with a critical VC3 installed for on-demand emergency calls must guarantee the best quality of service on the line; therefore, they lower all thresholds so that the slightest error raises a TCA.

## 12.2 Intermediate-Path Performance Monitoring

Intermediate-path performance monitoring (IPPM) allows a nonterminating node to transparently monitor a constituent channel of an incoming transmission signal. ONS 15600 SDH networks only use line terminating equipment (LTE), not path terminating equipment (PTE). The following cards are LTE equipment in the ONS 15600 SDH system:

- OC48/STM16 SR/SH 16 Port 1310
- OC48/STM16 LR/LH 16 Port 1550
- OC192/STM64 SR/SH 4 Port 1310
- OC192/STM64 LR/LH 4 Port 1550
- OC192LR/STM64 4 Port ITU C-Band

IPPM enables LTE cards to monitor near-end path PM data on individual virtual containers (VC) payloads. After enabling IPPM on provisioned VC3 or VC4 ports, service providers can monitor large amounts of VC traffic through intermediate nodes, thus making troubleshooting and maintenance activities more efficient.

IPPM occurs only on VC4 paths that have IPPM enabled, and TCAs are raised only for PM parameters on the selected IPPM paths. The monitored IPPMs are VC4 HP-EB, VC4 HP-ES, VC4 HP-SES, VC4 HP-UAS, and VC4 HP-BBE. The following ratio parameters are provided: VC4 HP-BBER, VC4 HP-ESR, and VC4 HP-SESR. To enable IPPM, refer to the *Cisco ONS 15600 SDH Procedure Guide*.

The ONS 15600 SDH performs IPPM by examining the overhead in the monitored path and reading all of the near-end path performance monitoring parameters in the incoming transmission direction. The IPPM process allows the path overhead to pass bidirectionally through the node completely unaltered.

For detailed information about specific performance monitoring parameters, see the [“12.4 Performance-Monitoring Parameter Definitions” section on page 12-3](#).

## 12.3 Pointer Justification Count

Pointers are used to compensate for frequency and phase variations. Pointer justification counts indicate timing differences on SDH networks. When a network is not synchronized, frequency and phase variations occur on the transported signal. Excessive frequency and phase variations can cause terminating equipment to slip. These variations also cause slips at the SDH and plesiosynchronous digital hierarchy (PDH) boundaries.

Slips cause different effects in service. Voice service has intermittent audible clicks. Compressed voice technology has short transmission errors or dropped calls. Fax machines lose scanned lines or experience dropped calls. Digital video transmission has distorted pictures or frozen frames. Encryption service loses the encryption key, which causes data to be transmitted again.

Pointers align the phase variations in VC4 and TU payloads. The VC4 payload pointer is located in the H1 and H2 bytes of the line overhead. Clocking differences are measured by the offset in bytes from the pointer to the first byte of the VC4 virtual container (VC) called the J1 byte. A small number of pointer justification counts per day is not cause for concern. If the pointer justification count continues to rise or becomes large, action must be taken to correct the problem.

You can enable positive pointer justification count (PPJC) and negative pointer justification count (NPJC) performance monitoring parameters for LTE cards.

PPJC is a count of path-detected (PPJC-Pdet) or path-generated (PPJC-Pgen) positive pointer justifications depending on the specific PM name. NPJC is a count of path-detected (NPJC-Pdet) or path-generated (NPJC-Pgen) negative pointer justifications depending on the specific PM name.

A consistent pointer justification count indicates clock synchronization problems between nodes. A difference between the counts means the node transmitting the original pointer justification has timing variations with the node detecting and transmitting this count. Positive pointer adjustments occur when the frame rate of the VC is too slow in relation to the rate of the VC4.

For pointer justification count definitions, see the “[12.4 Performance-Monitoring Parameter Definitions](#)” section on page 12-3. In CTC, the PM count fields for PPJC and NPJC appear white and blank unless IPPM is enabled.

## 12.4 Performance-Monitoring Parameter Definitions

Table 12-1 gives definitions for each type of performance-monitoring parameter found in this chapter.

**Table 12-1 Performance Monitoring Parameters**

Parameter	Definition
MS-EB	Multiplex Section Errored Block (MS-EB) indicates that one or more bits are in error within a block.
MS-ES	Multiplex Section Errored Second (MS-ES) is a one-second period with one or more errored blocks or at least one defect.
MS-SES	Multiplex Section Severely Errored Second (MS-SES) is a one-second period which contains 30 percent or more errored blocks or at least one defect. SES is a subset of ES. For more information, see ITU-T G.829 Section 5.1.3.
MS-BBE	Multiplex Section Background Block Error (MS-BBE) is an errored block not occurring as part of an SES.
MS-UAS	Multiplex Section Unavailable Seconds (MS-UAS) is a count of the seconds when the section was unavailable. A section becomes unavailable when ten consecutive seconds occur that qualify as MS-SESs, and it continues to be unavailable until ten consecutive seconds occur that do not qualify as MS-SESs. When the condition is entered, MS-SESs decrement and then count toward MS-UAS.
MS-FC	Count of the number of occurrences of near-end failure events, and is incremented by one each time a near-end failure event begins. Failure counts are incremented during unavailable time.

**Table 12-1 Performance Monitoring Parameters (continued)**

<b>Parameter</b>	<b>Definition</b>
MS-ESR	Multiplex Section Errored Second Ratio (MS-ESR) is the ratio of errored seconds to total seconds in available time during a fixed measurement interval.
MS-SESR	Multiplex Section Severely Errored Second ratio (MS-SESR) is the ratio of SES to total seconds in available time during a fixed measurement interval.
MS-BBER	Multiplex Section Background Block Error Ratio (MS-BBER) is the ratio of BBE to total blocks in available time during a fixed measurement interval. The count of total blocks excludes all blocks during SESs.
MS-PSC-W	For a working line in a 2-fiber MS-SPRing, Multiplex Section Protection Switching Count-Working (MS-PSC-W) is a count of the number of times traffic switches away from the working capacity in the failed line and back to the working capacity after the failure is cleared. MS-PSC-W increments on the failed working line and MS-PSC increments on the active protect line. For a working line in a 4-fiber MS-SPRing, MS-PSC-W is a count of the number of times service switches from a working line to a protection line plus the number of times it switches back to the working line. MS-PSC-W increments on the failed line and MS-PSC-R or MS-PSC-S increments on the active protect line.
MS-PSD-W	For a working line in a two-fiber MS-SPRing, Multiplex Section Protection Switching Duration-Working (MS-PSD-W) is a count of the number of seconds that service was carried on the protection line. MS-PSD-W increments on the failed working line and MS-PSD increments on the active protect line.
HP-EB	High-Order Path Errored Block (HP-EB) indicates that one or more bits are in error within a block.
HP-ES	High-Order Path Errored Second (HP-ES) is a one-second period with one or more errored blocks or at least one defect.
HP-SES	High-Order Path Severely Errored Seconds (HP-SES) is a one-second period containing 30 percent or more errored blocks or at least one defect. SES is a subset of ES.
HP-BBE	High-Order Path Background Block Error (HP-BBE) is an errored block not occurring as part of an SES.
HP-UAS	High-Order Path Unavailable Seconds (HP-UAS) is a count of the seconds when the VC path was unavailable. A high-order path becomes unavailable when ten consecutive seconds occur that qualify as HP-SESs, and it continues to be unavailable until ten consecutive seconds occur that do not qualify as HP-SESs.
HP-FC	Count of the number of occurrences of near-end failure events, and is incremented by one each time a near-end failure event begins. Failure counts are incremented during unavailable time.
RS-EB	Regenerator Section Errored Block (RS-EB) indicates that one or more bits are in error within a block.
RS-ES	Regenerator Section Errored Second (RS-ES) is a one-second period with one or more errored blocks or at least one defect.
RS-SES	Regenerator Section Severely Errored Second (RS-SES) is a one-second period which contains 30 percent or more errored blocks or at least one defect. SES is a subset of ES.

**Table 12-1** Performance Monitoring Parameters (continued)

Parameter	Definition
RS-BBE	Regenerator Section Background Block Error (RS-BBE) is an errored block not occurring as part of an SES.
RS-ESR	Regenerator Section Errored Second Ratio (RS-ESR) is the ratio of errored seconds to total seconds in available time during a fixed measurement interval.
RS-SESR	Regenerator Section Severely Errored Second Ratio (RS-SES) is the ratio of SES to total seconds in available time during a fixed measurement interval.
RS-BBER	Regenerator Section Background Block Error Ratio (RS-BBE) is the ratio of BBE to total blocks in available time during a fixed measurement interval. The count of total blocks excludes all blocks during SESs.
RS-UAS	Regenerator Section Unavailable Second (RS-UAS) is a count of the seconds when the regenerator section was unavailable. A section becomes unavailable when ten consecutive seconds occur that qualify as RS-UASs, and it continues to be unavailable until ten consecutive seconds occur that do not qualify as RS-UASs.

## 12.5 Optical Card Performance Monitoring

The following sections define performance monitoring parameters for the OC-48/STM16, and OC-192/STM64 optical cards.

### 12.5.1 OC-48/STM16, and OC-192/STM64 Card Performance Monitoring Parameters

[Figure 12-1](#) shows where overhead bytes detected on the Application-Specific Integrated Circuits (ASICs) produce performance monitoring parameters for the OC-48/STM16, and OC-192/STM64 optical cards.

Figure 12-1 PM Read Points on the OC-48/STM16, and OC-192/STM64 Cards

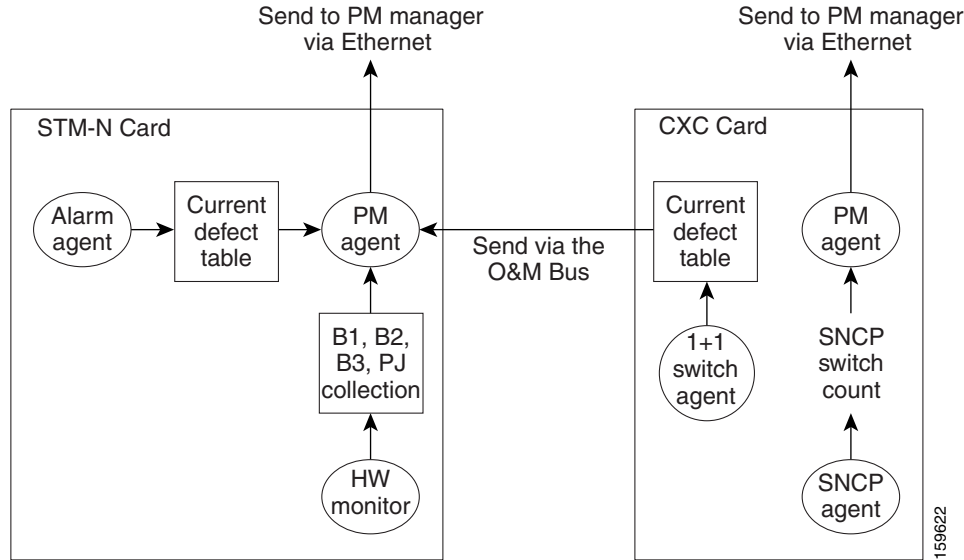
**Note**

For PM locations relating to protection switch counts, see the Telcordia GR-1230-CORE document.

Table 12-2 lists the near-end and far-end section layer PMs.

Table 12-2 OC48/STM16, and OC-192/STM64 Card PMs

RS (NE/FE)	MS (NE/FE)	PSC (NE) <sup>1, 2</sup>	PJC (NE)	VC4 and VC4-Xc HP Path (NE)
RS-EB	MS-EB	MS-PSC	HP-PPJC-Pdet	HP-BBE
RS-ES	MS-ES	MS-PSD	HP-NPJC-Pdet	HP-BBER
RS-SES	MS-SES	MS-PSC-W	HP-PPJC-Pgen	HP-EB
RS-OFS	MS-UAS	MS-PSD-W	HP-NPJC-Pgen	HP-ES
RS-BBE	MS-FC		HP-PJCDiff	HP-ESR
	MS-BBE		HP-PJCS-Pdet	HP-SES
			HP-PJCS-Pgen	HP-SESR
				HP-UAS

- SDH path performance monitoring parameters increment only if IPPM is enabled. For additional information, see the "12.2 Intermediate-Path Performance Monitoring" section on page 12-2. To monitor SDH path performance monitoring parameters, log into the far-end node directly.
- For information about troubleshooting path protection configurations (path protection) switch counts, refer to the *Cisco ONS 15600 SDH Reference Manual* for information about creating circuits with protection switching.

## 12.5.2 Physical Layer Parameters

The ONS 15600 SDH retrieves the OPR, OPT, and LBC from the line card and stores these values with the PM counts for the 15-minute and 1-day periods. You can retrieve current OPR, OPT, and LBC values for each port by displaying the card view in CTC and clicking the Maintenance > Transceiver tabs.

The physical layer performance parameters consist of normalized and non-normalized values of LBC, OPT, and OPR. Table 12-3 defines the non-normalized values.

**Table 12-3 Non-Normalized Transceiver Physical Optics for the OC-48/STM16, and OC-192/STM64 Cards**

Parameter	Definition
Non-normalized LBC (mA) <sup>1</sup>	The actual operating value of laser bias current (mA) for the specified card port.
Non-normalized OPR (dbm) <sup>2</sup>	The actual operating value of optical power received (dBm) for the specified card port.
Non-normalized OPT (dbm) <sup>1</sup>	The actual operating value of optical power transmitted (dBm) for the specified card port.

1. This value should be somewhat consistent from port to port and cannot be configured.
2. This value will vary from port to port because of received optical signal power differences. This value can be configured by calibrating the nominal value to the initial receive power level when the port is put in service.

## 12.6 ASAP Card Performance Monitoring

The following sections define performance monitoring parameters for the Any Service Any Port (ASAP) card.

### 12.6.1 ASAP Card Optical Performance Monitoring Parameters

Table 12-4 lists the near-end and far-end section layer PMs.

**Table 12-4 ASAP Card PMs**

RS (NE/FE)	MS (NE/FE)	PSC (NE) <sup>1</sup>	PJC (NE) <sup>2</sup>	VC4 and VC4-Xc HP Path (NE) <sup>3</sup>
RS-EB	MS-EB	MS-PSC	HP-PPJC-Pdet	HP-BBE
RS-ES	MS-ES	MS-PSD	HP-NPJC-Pdet	HP-BBER
RS-SES	MS-SES	MS-PSC-W	HP-PPJC-Pgen	HP-EB
RS-OFS	MS-OFS	MS-PSD-W	HP-NPJC-Pgen	HP-ES
RS-BBE	MS-BBE		HP-PJCDiff	HP-ESR
			HP-PJCS-Pdet	HP-SES
			HP-PJCS-Pgen	HP-SESR
				HP-UAS

1. SDH path performance monitoring parameters increment only if IPPM is enabled. For additional information, see the “[12.2 Intermediate-Path Performance Monitoring](#)” section on page 12-2. To monitor SDH path performance monitoring parameters, log into the far-end node directly.
2. In CTC, the count fields for HP-PPJC and HP-NPJC PM parameters appear white and blank unless they are enabled on the Provisioning > Line tab. See the “[12.3 Pointer Justification Count](#)” section on page 12-2.
3. SDH path PM parameters do not increment unless IPPM is enabled. See the “[12.2 Intermediate-Path Performance Monitoring](#)” section on page 12-2.

## 12.6.2 ASAP Card Ethernet Performance Monitoring Parameters

CTC provides Ethernet performance information, including line-level parameters, port bandwidth consumption, and historical Ethernet statistics. The ASAP card Ethernet performance information is divided into Ether Ports and POS Ports windows within the card view Performance tab window.

### 12.6.2.1 ASAP Card Ether Port Statistics Window

The Ethernet Ether Ports statistics window lists Ethernet parameters at the line level. The Statistics window provides buttons to change the statistical values. The Baseline button resets the displayed statistics values to zero. The Refresh button manually refreshes statistics. Auto-Refresh sets a time interval at which automatic refresh occurs. The ASAP Statistics window also has a Clear button. The Clear button sets the values on the card to zero, but does not reset the ASAP card.

During each automatic cycle, whether auto-refreshed or manually refreshed (using the Refresh button), statistics are added cumulatively and are not immediately adjusted to equal total received packets until testing ends. To see the final PM count totals, allow a few moments for the PM window statistics to finish testing and update fully. PM counts are also listed in the ASAP card Performance > History window.

Table 12-5 defines the ASAP card statistics parameters.

**Table 12-5** ASAP Ethernet Statistics Parameters

Parameter	Meaning
Time Last Cleared	A time stamp indicating the last time statistics were reset.
Link Status	Indicates whether the Ethernet link is receiving a valid Ethernet signal (carrier) from the attached Ethernet device; up means present, and down means not present.
ifInOctets	Number of bytes received since the last counter reset.
ifInUcastPkts	Number of unicast packets received since the last counter reset.
ifInMulticastPkts	Number of multicast packets received since the last counter reset.
ifInBroadcastPkts	Number of broadcast packets received since the last counter reset.
etherStatsOversizePkts	The total number of packets received that were longer than 1518 octets (excluding framing bits, but including FCS octets) and were otherwise well formed. Note that for tagged interfaces, this number becomes 1522 bytes.
dot3StatsFCSErrors	A count of frames received on a particular interface that are an integral number of octets in length but do not pass the FCS check.
etherStatsUndersizePkts	The total number of packets received that were less than 64 octets long (excluding framing bits, but including FCS octets) and were otherwise well formed.



**Table 12-5** ASAP Ethernet Statistics Parameters (continued)

Parameter	Meaning
etherStatsJabbers	The total number of packets received that were longer than 1518 octets (excluding framing bits, but including FCS octets), and had either a bad Frame Check Sequence (FCS) with an integral number of octets (FCS Error) or a bad FCS with a non-integral number of octets (Alignment Error).
dot3StatsAlignmentErrors	A count of frames received on a particular interface that are not an integral number of octets in length and do not pass the FCS check.
ifOutOctets	Number of bytes transmitted since the last counter reset.
ifOutUcastPkts	Number of unicast packets transmitted.
ifOutMulticastPkts	Number of multicast packets transmitted.
ifOutBroadcastPkts	Number of broadcast packets transmitted.
etherStatsDropEvents	Number of received frames dropped at the port level.
rxPauseFrames	Number of received Ethernet IEEE 802.3z pause frames.
txPauseFrames	Number of transmitted IEEE 802.3z pause frames.
etherStatsOctets	The total number of bytes of data (including those in bad packets) received on the network (excluding framing bits but including FCS bytes).
etherStatsBroadcastPkts	The total number of good packets received that were directed to the broadcast address. Note that this does not include multicast packets.
etherStatsMulticastPkts	The total number of good packets received that were directed to a multicast address. Note that this number does not include packets directed to the broadcast address.
etherStatsFragments	The total number of packets received that were less than 64 bytes in length (excluding framing bits but including FCS bytes) and had either a bad FCS with an integral number of bytes (FCS error) or a bad FCS with a nonintegral number of bytes (alignment error).  <b>Note</b> It is entirely normal for etherStatsFragments to increment. This is because it counts both runs (which are normal occurrences due to collisions) and noise hits.
etherStatsPkts64Octets	The total number of packets (including bad packets) received that were 64 bytes in length (excluding framing bits but including FCS bytes).
etherStatsPkts65to127Octets	The total number of packets (including bad packets) received that were between 65 and 127 bytes in length inclusive (excluding framing bits but including FCS bytes).
etherStatsPkts128to255Octets	The total number of packets (including bad packets) received that were between 128 and 255 bytes in length inclusive (excluding framing bits but including FCS bytes).

**Table 12-5** ASAP Ethernet Statistics Parameters (continued)

Parameter	Meaning
etherStatsPkts256to511Octets	The total number of packets (including bad packets) received that were between 256 and 511 bytes in length inclusive (excluding framing bits but including FCS bytes).
etherStatsPkts512to1023Octets	The total number of packets (including bad packets) received that were between 512 and 1023 bytes in length inclusive (excluding framing bits but including FCS bytes).
etherStatsPkts1024to1518Octets	The total number of packets (including bad packets) received that were between 1024 and 1518 bytes in length inclusive (excluding framing bits but including FCS bytes).
ifInDiscards	The number of inbound packets which were chosen to be discarded even though no errors had been detected to prevent their being deliverable to a higher-layer protocol. One possible reason for discarding such a packet could be to free up buffer space.
ifOutDiscards	The number of outbound packets which were chosen to be discarded even though no errors had been detected to prevent their being transmitted. One possible reason for discarding such a packet could be to free up buffer space.
ifInErrors	The number of inbound packets (or transmission units) that contained errors preventing them from being deliverable to a higher-layer protocol.
dot3StatsFrameTooLongs	A count of frames received on a particular interface that exceed the maximum permitted frame size.
etherStatsPkts	The total number of packets (including bad packets, broadcast packets, and multicast packets) received.
ifOutErrors	The number of outbound packets (or transmission units) that could not be transmitted because of errors.
dot3StatsInternalMacTxErrors	A count of frames for which reception on a particular interface fails due to an internal MAC sublayer receive error. A frame is only counted by an instance of this object if it is not counted by the corresponding instance of either the dot3StatsFrameTooLongs object, the dot3StatsAlignmentErrors object, or the dot3StatsFCSErrors object. The precise meaning of the count represented by an instance of this object is implementation-specific. In particular, an instance of this object may represent a count of receive errors on a particular interface that are not otherwise counted.

**Table 12-5** ASAP Ethernet Statistics Parameters (continued)

Parameter	Meaning
dot3StatsInternalMacRxErrors	A count of frames for which reception on a particular interface fails due to an internal MAC sublayer receive error. A frame is only counted by an instance of this object if it is not counted by the corresponding instance of either the dot3StatsFrameTooLongs object, the dot3StatsAlignmentErrors object, or the dot3StatsFCSErrors object. The precise meaning of the count represented by an instance of this object is implementation-specific. In particular, an instance of this object may represent a count of receive errors on a particular interface that are not otherwise counted.
dot3StatsSymbolErrors	A count of frames for which transmission on a particular interface fails due to an internal MAC sublayer transmit error. A frame is only counted by an instance of this object if it is not counted by the corresponding instance of either the dot3StatsLateCollisions object, the dot3StatsExcessiveCollisions object, or the dot3StatsCarrierSenseErrors object. The precise meaning of the count represented by an instance of this object is implementation-specific. In particular, an instance of this object might represent a count of transmission errors on a particular interface that are not otherwise counted.

### 12.6.2.2 ASAP Card Ether Ports Utilization Window

The Ether Ports Utilization window shows the percentage of Tx and Rx line bandwidth used by the Ethernet ports during consecutive time segments. The Utilization window provides an Interval menu that enables you to set time intervals of 1 minute, 15 minutes, 1 hour, and 1 day. Line utilization is calculated with the following formulas:

$$\text{Rx} = (\text{inOctets} + \text{inPkts} * 20) * 8 / 100\% \text{ interval} * \text{maxBaseRate}$$

$$\text{Tx} = (\text{outOctets} + \text{outPkts} * 20) * 8 / 100\% \text{ interval} * \text{maxBaseRate}$$

The interval is defined in seconds. The maxBaseRate is defined by raw bits per second in one direction for the Ethernet port (that is, 1 Gbps). [Table 12-6](#) provides the maxBaseRate for ASAP cards.

**Table 12-6** maxBaseRate for VC Circuits

VC	maxBaseRate
VC3	51840000
VC4	155000000
VC4-2c	311000000
VC4-4c	622000000

**Note**

Line utilization numbers express the average of ingress and egress traffic as a percentage of capacity.

### 12.6.2.3 ASAP Card Ether Ports History Window

The Ethernet Ether Ports History window lists past Ethernet statistics for the previous time intervals. The History window displays the statistics for each port for the number of previous time intervals as shown in [Table 12-7](#). The listed parameters are defined in [Table 12-5 on page 12-8](#).

**Table 12-7 Ethernet History Statistics per Time Interval**

Time Interval	Number of Intervals Displayed
1 minute	60 previous time intervals
15 minutes	32 previous time intervals
1 hour	24 previous time intervals
1 day (24 hours)	7 previous time intervals

### 12.6.2.4 ASAP Card POS Ports Statistics Parameters

The Ethernet POS Ports statistics window lists Ethernet POS parameters at the line level.

[Table 12-8](#) defines the ASAP card Ethernet POS Ports parameters.

**Table 12-8 ASAP Card POS Ports Parameters**

Parameter	Meaning
Time Last Cleared	A time stamp indicating the last time statistics were reset.
Link Status	Indicates whether the Ethernet link is receiving a valid Ethernet signal (carrier) from the attached Ethernet device; up means present, and down means not present.
gfpStatsRxFrame	Number of received GFP frames.
gfpStatsTxFrame	Number of transmitted GFP frames.
gfpStatsRxOctets	Number of GFP bytes received.
gfpStatsTxOctets	Number of GFP bytes transmitted.
gfpStatsRxCRCErrors	Number of packets received with a payload FCS error.
gfpStatsRxMBitErrors	Sum of all the multiple bit errors. In the GFP CORE HDR at the GFP-T receiver these are uncorrectable.
gfpStatsRxSBitErrors	Sum of all the single bit errors. In the GFP CORE HDR at the GFP-T receiver these are correctable.
gfpStatsRxTypeInvalid	Number of receive packets dropped due to Client Data Frame UPI error.
hdlcInOctets	Number of bytes received (from the SONET/SDH path) prior to the bytes undergoing HLDC decapsulation by the policy engine.
hdlcOutOctets	Number of bytes transmitted (to the SONET/SDH path) after the bytes undergoing HLDC encapsulation by the policy engine.
rxTotalPkts	Number of received packets.
txTotalPkts	Number of transmitted packets
hdlcRxAborts	Number of received packets aborted on input.

**Table 12-8** ASAP Card POS Ports Parameters (continued)

Parameter	Meaning
mediaIndStatsRxFramesBadCRC	Number of received frames with CRC error.
rxPktsDroppedInternalCongestion	Number of received packets dropped due to overflow in frame buffer.
mediaIndStatsRxShortPkts	Number of received packets that are too small.
mediaIndStatsRxFramesTruncated	Number of received frames with length of 36 bytes or less.
mediaIndStatsRxFramesTooLong	Number of received frames that are too long. The maximum is the programmed max frame size (for VSAN support); if the max frame size is set to default, then the max is 2112 byte payload plus 36 byte header, which is 2148.

### 12.6.2.5 ASAP Card POS Ports Utilization Window

The POS Ports Utilization window shows the percentage of Tx and Rx line bandwidth used by the POS ports during consecutive time segments. The Utilization window provides an Interval menu that enables you to set time intervals of 1 minute, 15 minutes, 1 hour, and 1 day. Line utilization is calculated with the following formulas:

$$\text{Rx} = (\text{inOctets} * 8) / \text{interval} * \text{maxBaseRate}$$

$$\text{Tx} = (\text{outOctets} * 8) / \text{interval} * \text{maxBaseRate}$$

The interval is defined in seconds. The maxBaseRate is defined by raw bits per second in one direction for the Ethernet port (that is, 1 Gbps). The maxBaseRate for ASAP cards is shown in [Table 12-6 on page 12-11](#).

**Note**

Line utilization numbers express the average of ingress and egress traffic as a percentage of capacity.

### 12.6.2.6 ASAP Card POS Ports History Window

The Ethernet POS Ports History window lists past Ethernet POS Ports statistics for the previous time intervals. The History window displays the statistics for each port for the number of previous time intervals as shown in [Table 12-7](#). The listed parameters are defined in [Table 12-8 on page 12-12](#).

