



Install the Shelf and Backplane Cable

This chapter provides procedures for installing the Cisco ONS 15454. For a summary of the tools and equipment required for installation, see the [“Required Tools and Equipment”](#) section on page 1-2.

Before You Begin

This section lists the chapter procedures (NTPs). Turn to a procedure for applicable tasks (DLPs).

1. [NTP-A1 Unpack and Inspect the ONS 15454 Shelf Assembly, page 1-4](#)—Complete this procedure before continuing with the [“NTP-A2 Install the Shelf Assembly”](#) procedure on page 1-5.
2. [NTP-A2 Install the Shelf Assembly, page 1-5](#)—Complete this procedure to install the shelf assembly in a rack.
3. [NTP-A3 Open and Remove the Front Door, page 1-6](#)—Complete this procedure to access the equipment before continuing with other procedures.
4. [NTP-A4 Remove the Backplane Covers, page 1-7](#)—Complete this procedure to access the backplane before continuing with other procedures.
5. [NTP-A5 Install the EIAs, page 1-7](#)—Complete this procedure if you plan to install electrical cards. This procedure is a prerequisite to the [“NTP-A9 Install the Electrical Card Cables on the Backplane”](#) procedure on page 1-22.
6. [NTP-A6 Install the Power and Ground, page 1-9](#)—Complete this procedure before continuing with the [“NTP-A7 Install the Fan-Tray Assembly”](#) procedure on page 1-10.
7. [NTP-A7 Install the Fan-Tray Assembly, page 1-10](#)—Complete this procedure to install the fan-tray assembly in the shelf.
8. [NTP-A119 Install the Alarm Expansion Panel, page 1-13](#)—Complete this procedure if you are planning to install the Alarm Interface Controller–International (AIC-I) card and want to increase the number of alarm contacts provided by the AIC-I card.
9. [NTP-A8 Attach Wires to Alarm, Timing, LAN, and Craft Pin Connections, page 1-16](#)—Complete this procedure as needed to set up wire-wrap pin connections.
10. [NTP-A120 Install an External Wire-Wrap Panel to the AEP, page 1-17](#)—Complete this procedure to connect an external wire-wrap panel to the alarm expansion panel (AEP).
11. [NTP-A9 Install the Electrical Card Cables on the Backplane, page 1-22](#)—Complete this procedure if you plan to install electrical card cables.
12. [NTP-A10 Route Electrical Cables, page 1-23](#)—Complete this procedure as needed to route electrical cables installed on the backplane.

13. [NTP-A11 Install the Rear Cover, page 1-23](#)—Complete this procedure as needed to install the rear cover.
14. [NTP-A13 Perform the Shelf Installation Acceptance Test, page 1-30](#)—Complete this procedure to determine if you have correctly completed all other procedures in the chapter.

**Warning**

Only trained and qualified personnel should be allowed to install, replace, or service this equipment. Statement 1030

**Warning**

This unit is intended for installation in restricted access areas. A restricted access area is where access can only be gained by service personnel through the use of a special tool, lock and key, or other means of security, and is controlled by the authority responsible for the location. Statement 37

**Warning**

Suitable for mounting on concrete or other non-combustible surface only. Statement 345

**Warning**

The covers are an integral part of the safety design of the product. Do not operate the unit without the covers installed. Statement 1077

Required Tools and Equipment

You need the following tools and equipment to install and test the ONS 15454.

Cisco-Supplied Materials

The following materials are required and are shipped with the ONS 15454 shelf (wrapped in plastic). The number in parentheses gives the quantity of the item included in the package.

- #12-24 x 3/4 pan-head Phillips mounting screws (48-1004-XX, 48-1007-XX) (8)
- #12 -24 x 3/4 socket set screws (48-1003-XX) (2)
- T-handle #12-24 hex tool for set screws (1)
- ESD wrist strap with 1.8 m (6 ft) coil cable (1)
- Tie wraps (10)
- Pinned hex (Allen) key for front door (1)
- Spacers (50-1193-XX) (4)
- Spacer mounting brackets (2)
- Clear plastic rear cover (1)
- External (bottom) brackets for the fan-tray air filter
- Shelf accessory kit (53-2329-XX) (optional)
 - Two mounting bars (700-19701-XX)
 - Four 1-inch standoffs (50-1193-01)

- Four 1 3/8-inch standoffs (50-1492-01)
- Eight 2-inch standoffs (50-1453-01)
- Four flathead screws, 6-32 x 0.5 (48-2116-01)
- Standoff kit (53-0795-XX):
 - Plastic fiber management guides (2)
 - Fan filter bracket screws (53-48-0003) (6)

The following materials are required to install the optional air ramp. The number in parentheses gives the quantity of the item included in the package:

- M4.0x 8mm, SS pan-head Phillips mounting screws (2)
- Mounting brackets, 19 inch (482.6 mm), 23 inch (584.2 mm) (2)

User-Supplied Materials

The following materials and tools are required but are not supplied with the ONS 15454:

- One or more of the following equipment racks:
 - 19-inch ANSI Standard (Telcordia GR-63-CORE) (482.6 mm) rack; total width 22 inches (558.8 mm)
 - 23-inch ANSI Standard (Telcordia GR-63-CORE) (584.2 mm) rack; total width 26 inches (660.4 mm)
- Fuse panel
- Power cable (from fuse and alarm panel to assembly), #10 AWG, copper conductors, 194 degrees Fahrenheit (90 degrees Celsius)
- Ground cable #6 AWG stranded
- Alarm cable pairs for all alarm connections, #22 or #24 AWG (0.51 mm² or 0.64 mm²), solid tinned
- 100-ohm shielded building integrated timing supply (BITS) clock cable pair #22 or #24 AWG (0.51 mm² or 0.64 mm²), twisted-pair T1-type
- Single-mode SC fiber jumpers with UPC polish (55 dB or better) for optical (OC-N) cards
- Shielded coaxial cable terminated with SMB or BNC connectors for DS-3 cards
- Shielded ABAM cable terminated with AMP Champ connectors or unterminated for DS1N-14 cards with #22 or #24 AWG (0.51 mm² or 0.64 mm²) ground wire (typically about two ft [61 cm] in length)
- 6-pair #29 AWG double-shielded cable
- Tie wraps and/or lacing cord
- Labels
- Listed pressure terminal connectors, typically dual lug type; connectors must be suitable for #6 AWG copper conductors with stud size and spacing per equipment rack specifications; connection to office ground typically through H-TAP compression connector, according to site practice

Tools Needed

The following tools are needed to install an ONS 15454:

- #2 Phillips screwdriver

- Medium slot-head screwdriver
- Small slot-head screwdriver
- Wire wrapper
- Wire cutters
- Wire strippers
- Crimp tool
- BNC insertion tool

Test Equipment

The following test equipment is needed to install an ONS 15454:

- Voltmeter
- Optical power meter (for use with fiber optics only)
- Bit error rate (BER) tester, DS-1 and DS-3

NTP-A1 Unpack and Inspect the ONS 15454 Shelf Assembly

Purpose	This procedure unpacks the ONS 15454 and verifies the contents.
Tools/Equipment	Pinned hex (Allen) key for front door
Prerequisite Procedures	None
Required/As Needed	Required
Onsite/Remote	Onsite
Security Level	None



Note

The ONS 15454 high-density shelf (15454-SA-HD) is required if you want to use the high-density electrical cards (DS3/EC1-48 and DS1/E1-56 cards).

- Step 1** Complete the [“DLP-A1 Unpack and Verify the Shelf Assembly”](#) task on page 17-1.
- Step 2** Complete the [“DLP-A2 Inspect the Shelf Assembly”](#) task on page 17-2.
- Step 3** Continue with the [“NTP-A2 Install the Shelf Assembly”](#) procedure on page 1-5.

Stop. You have completed this procedure.

NTP-A2 Install the Shelf Assembly

Purpose	This procedure reverses the mounting bracket and mounts shelf assemblies in a rack.
Tools/Equipment	#2 Phillips screwdriver Medium slot-head screwdriver Small slot-head screwdriver Pinned hex key Two set screws (48-1003-XX)
Prerequisite Procedures	NTP-A1 Unpack and Inspect the ONS 15454 Shelf Assembly, page 1-4
Required/As Needed	Required
Onsite/Remote	Onsite
Security Level	None



Warning

To prevent the system from overheating, do not operate it in an area that exceeds the maximum recommended ambient temperature of: 131°F (55°C). Statement 1047



Warning

To prevent airflow restriction, allow at least 1 inch (25.4 mm) of clearance around the ventilation openings.Statement 1076



Warning

To prevent bodily injury when mounting or servicing this unit in a rack, you must take special precautions to ensure that the system remains stable. The following guidelines are provided to ensure your safety:

- **This unit should be mounted at the bottom of the rack if it is the only unit in the rack.**
- **When mounting this unit in a partially filled rack, load the rack from the bottom to the top with the heaviest component at the bottom of the rack.**
- **If the rack is provided with stabilizing devices, install the stabilizers before mounting or servicing the unit in the rack.** Statement 1006



Warning

The ONS 15454 must have 1 inch (25.4 mm) of airspace below the installed shelf assembly to allow air flow to the fan intake. The air ramp (the angled piece of sheet metal on top of the shelf assembly) provides this spacing and should not be modified in any way. Statement 385



Note

The 10-Gbps-compatible shelf assembly (15454-SA-HD) and fan-tray assembly (15454-FTA3) are required with the ONS 15454 XC10G, OC-192, and OC-48 any slot (AS) cards.

-
- Step 1** Complete the “[DLP-A3 Reverse the Mounting Bracket to Fit a 19-inch \(482.6 mm\) Rack](#)” task on [page 17-2](#) if you need to convert from a 23-inch (584.2 mm) to a 19-inch (482.6 mm) rack.
- Step 2** To install the air filter on the bottom of the shelf rather than below the fan-tray assembly, complete the “[DLP-A4 Install the External Brackets and Air Filter](#)” task on [page 17-3](#).
- Step 3** Complete the necessary rack mount task:
- [DLP-A5 Mount the Shelf Assembly in a Rack \(One Person\)](#), [page 17-5](#)
 - [DLP-A6 Mount the Shelf Assembly in a Rack \(Two People\)](#), [page 17-6](#)
 - [DLP-A7 Mount Multiple Shelf Assemblies in a Rack](#), [page 17-7](#)
- Step 4** Continue with the “[NTP-A3 Open and Remove the Front Door](#)” procedure on [page 1-6](#).
- Stop. You have completed this procedure.**
-

NTP-A3 Open and Remove the Front Door

Purpose	This procedure opens and removes the front door to access the equipment.
Tools/Equipment	Open-end wrench Pinned hex key
Prerequisite Procedures	NTP-A2 Install the Shelf Assembly , page 1-5
Required/As Needed	Required
Onsite/Remote	Onsite
Security Level	None

-
- Step 1** Complete the “[DLP-A8 Open the Front Door](#)” task on [page 17-7](#).
- Step 2** As needed, complete the “[DLP-A9 Remove the Front Door](#)” task on [page 17-9](#).
- Step 3** Continue with the “[NTP-A4 Remove the Backplane Covers](#)” procedure on [page 1-7](#).
- Stop. You have completed this procedure.**
-

NTP-A4 Remove the Backplane Covers

Purpose	This procedure describes how to access the backplane by removing the covers. The backplane has two sheet metal covers (one on either side) and a lower backplane cover at the bottom.
Tools/Equipment	#2 Phillips screwdriver Medium slot-head screwdriver Small slot-head screwdriver
Prerequisite Procedures	NTP-A2 Install the Shelf Assembly, page 1-5 NTP-A3 Open and Remove the Front Door, page 1-6
Required/As Needed	Required
Onsite/Remote	Onsite
Security Level	None



Warning

The covers are an integral part of the safety design of the product. Do not operate the unit without the covers installed. Statement 1077

-
- Step 1** Complete the [“DLP-A10 Remove the Lower Backplane Cover”](#) task on page 17-10.
- Step 2** Complete the [“DLP-A11 Remove the Backplane Sheet Metal Cover”](#) task on page 17-10.
- Step 3** If you plan to install electrical interface assemblies (EIAs), continue with the [“NTP-A5 Install the EIAs”](#) procedure on page 1-7. If not, continue with the [“NTP-A6 Install the Power and Ground”](#) procedure on page 1-9.
- Stop. You have completed this procedure.**
-

NTP-A5 Install the EIAs

Purpose	This procedure describes how to install electrical interface assemblies (EIAs). Typically, an EIA panel is installed on the backplane during manufacturing, but EIA panels can be ordered separately. Refer to the <i>Cisco ONS 15454 Reference Manual</i> for descriptions of the EIAs.
Tools/Equipment	#2 Phillips screwdriver Medium slot-head screwdriver Small slot-head screwdriver Perimeter screws (9) Inner screws (12) Backplane cover screws (5) EIA card (SMB, BNC, AMP Champ, UBIC-V, UBIC-H, MiniBNC)
Prerequisite Procedures	NTP-A4 Remove the Backplane Covers, page 1-7
Required/As Needed	Required if the node will use electrical signals

Onsite/Remote	Onsite
Security Level	None

**Caution**

Always use the supplied ESD wristband when working with a powered ONS 15454. Plug the wristband cable into the ESD jack located on the lower-right outside edge of the shelf assembly.

**Note**

EIAs are normally factory installed. Verify that the correct EIA is installed on the shelf assembly. If not, install the correct EIA.

**Note**

You do not need to power down the shelf before removing or installing an EIA. An in-service upgrade of one EIA (A side or B side) is possible if all electrical traffic (DS-1, DS-3, DS3XM-6, and EC-1) is being carried on the other side.

- Step 1** Complete the “[DLP-A12 Install a BNC or High-Density BNC EIA](#)” task on page 17-11 as needed. BNCs are locking connectors; the high-density BNC provides access to every port on every card.
- Step 2** Complete the “[DLP-A373 Install a MiniBNC EIA](#)” task on page 20-55 as needed. The MiniBNC allows up to 96 DS-3 circuits on each side of the ONS 15454.
- Step 3** Complete the “[DLP-A13 Install an SMB EIA](#)” task on page 17-14 as needed. SMBs allow you to access every port on every card using more space and efficient cabling.
- Step 4** Complete the “[DLP-A14 Install the AMP Champ EIA](#)” task on page 17-15 as needed. AMP Champs are exclusive to DS-1 cables.
- Step 5** Complete the “[DLP-A190 Install a UBIC-V EIA](#)” task on page 18-58 as needed. The UBIC-V (vertical) EIAs allow you to use high-density electrical cards. The UBIC-V EIAs provide SCSI connectors.
- Step 6** Complete the “[DLP-A399 Install a UBIC-H EIA](#)” task on page 20-107 as needed. The UBIC-H (horizontal) EIAs allow you to use high-density electrical cards. The UBIC-H EIAs provide SCSI connectors.

**Note**

To attach cables to the EIAs, see the “[NTP-A9 Install the Electrical Card Cables on the Backplane](#)” procedure on page 1-22.

- Step 7** Continue with the “[NTP-A6 Install the Power and Ground](#)” procedure on page 1-9.

Stop. You have completed this procedure.

NTP-A6 Install the Power and Ground

Purpose	This procedure installs power feeds and grounds the ONS 15454.
Tools/Equipment	<p>#2 Phillips screwdriver</p> <p>Medium slot-head screwdriver</p> <p>Small slot-head screwdriver</p> <p>Screws</p> <p>Power cable (from fuse and alarm panel to assembly), #10 AWG, copper conductors, 194 degrees F (90 degrees C)</p> <p>Ground cable (from equipment frame to office ground), #6 AWG stranded</p> <p>Listed pressure terminal connectors, typically dual lug type; connectors must be suitable for #6 AWG copper conductors with stud size and spacing per equipment rack specifications; connection to office ground typically through H-TAP compression connector, according to site practice</p> <p>Wire cutters</p> <p>Wire strippers</p> <p>Crimp tool</p> <p>Fuse panel</p>
Prerequisite Procedures	NTP-A4 Remove the Backplane Covers, page 1-7
Required/As Needed	Required
Onsite/Remote	Onsite
Security Level	None



Warning

Before performing any of the following procedures, ensure that power is removed from the DC circuit. Statement 1003



Warning

This equipment is intended to be grounded. Ensure that the host is connected to earth ground during normal use. Statement 39



Warning

Use copper conductors only. Statement 1025



Warning

Connect the unit only to DC power source that complies with the safety extra-low voltage (SELV) requirements in IEC 60950 based safety standards. Statement 1033



Warning

This product requires short-circuit (overcurrent) protection, to be provided as part of the building installation. Install only in accordance with national and local wiring regulations. Statement 1045

**Warning****A readily accessible two-poled disconnect device must be incorporated in the fixed wiring.**

Statement 1022

**Warning****This unit might have more than one power supply connection. All connections must be removed to de-energize the unit.** Statement 1028**Caution**

Always use the supplied ESD wristband when working with a powered ONS 15454. Plug the wristband cable into the ESD jack located on the lower-right outside edge of the shelf assembly.

Step 1

Verify one of the following:

- If you have the 15454-SA-ANSI or 15454-SA-HD shelf, a 100-A fuse panel (30-A fuse per shelf minimum) should be installed. If not, install one according to manufacturer's instructions.
- If you have the 15454-SA-NEBS3 shelf, a standard 80-A fuse panel (20-A fuse per shelf minimum) should be installed. If not, install one according to manufacturer's instructions.

Step 2Complete the “[DLP-A16 Connect the Office Ground to the ONS 15454](#)” task on page 17-17.**Step 3**Complete the “[DLP-A17 Connect Office Power to the ONS 15454 Shelf](#)” task on page 17-18.**Step 4**Complete the “[DLP-A18 Turn On and Verify Office Power](#)” task on page 17-20.**Step 5**Continue with the “[NTP-A7 Install the Fan-Tray Assembly](#)” procedure on page 1-10.**Stop. You have completed this procedure.**

NTP-A7 Install the Fan-Tray Assembly

PurposeThis procedure installs the fan-tray assembly. Refer to the *Cisco ONS 15454 Reference Manual* for specific information about fan-tray assembly compatibility and air filters.**Tools/Equipment**#2 Phillips screwdriver
Medium slot-head screwdriver
Small slot-head screwdriver**Prerequisite Procedures** [NTP-A3 Open and Remove the Front Door](#), page 1-6
[NTP-A6 Install the Power and Ground](#), page 1-9**Required/As Needed** Required**Onsite/Remote** Onsite**Security Level** None**Caution**

Do not operate an ONS 15454 without a fan-tray air filter. A fan-tray air filter is mandatory.

**Caution**

The 15454-FTA3 fan-tray assembly can only be installed in ONS 15454 Release 3.1 or later shelf assemblies (15454-SA-ANSI, 800-19857; 15454-SA-HD, 800-24848). It includes a pin that does not allow it to be installed in ONS 15454 shelf assemblies released earlier than ONS 15454 Release 3.1 (15454-SA-NEBS3E, 15454-SA-NEBS3, and 15454-SA-R1, P/N 800-0714915454). Installing the 15454-FTA3 in a noncompliant shelf assembly might result in failure of the alarm interface panel (AIP), which in turn, will result in power loss to the fan-tray assembly.

**Note**

15454-CC-FTA is compatible with Software Release 2.2.2 and greater and shelf assemblies 15454-SA-HD and 15454-SA-ANSI.

**Caution**

You must place the edge of the air filter flush against the front of the fan-tray assembly compartment when installing the fan tray on top of the filter. Failure to do so could result in damage to the filter, the fan tray, or both.

**Caution**

Do not force a fan-tray assembly into place. Doing so can damage the connectors on the fan tray and/or the connectors on the back panel of the shelf assembly.

**Caution**

If the fan tray does not slide all the way to the back of the shelf assembly, pull the fan tray out and readjust the position of the reusable filter until the fan tray fits correctly. Be sure that the grid on the reusable filter is on the side facing the fan tray.

**Note**

If you are installing the ONS 15454 in an outside plant cabinet, remove the air filter to provide maximum cooling capabilities and to comply with Telcordia GR-487-CORE.

**Note**

To install the fan-tray assembly, it is not necessary to move any of the cable-management facilities.

Step 1

Install the air filter. The air filter can be installed internally between the fan tray and shelf assembly, or externally by mounting the air filter bracket on the bottom of the shelf assembly. Slide the air filter into the bracket.

**Caution**

Although the air filter can work with older fan trays if it is installed with either side facing up, Cisco recommends that you install it with the metal bracing facing up to preserve the surface of the filter. You must install the air filter with the metal bracing facing up with 15454-CC-FTA.

Step 2

Install the fan-tray assembly. The fan-tray assembly has locks on the outer edges. Press and hold the locks as you slide the fan-tray assembly into the shelf assembly. The electrical plug at the rear of the tray should plug into the corresponding receptacle on the assembly.

**Caution**

Do not force a fan-tray assembly into place. This can damage the connectors on the fan-tray assembly and/or the connectors on the back panel of the shelf assembly.

- Step 3** To verify that the tray has plugged into the backplane, look at the fan tray and listen to determine that the fans are running.

Figure 1-1 shows the location of the fan tray.

Figure 1-1 *Installing the Fan-Tray Assembly*

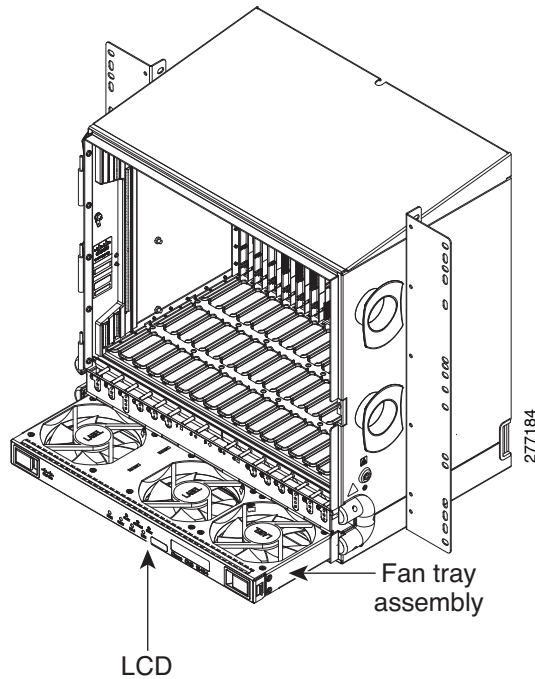

- Step 4** Continue with the “NTP-A119 Install the Alarm Expansion Panel” procedure on page 1-13 if you plan to install an alarm expansion panel (AEP). If not, continue with the “NTP-A8 Attach Wires to Alarm, Timing, LAN, and Craft Pin Connections” procedure on page 1-16.

Stop. You have completed this procedure.

NTP-A119 Install the Alarm Expansion Panel

Purpose	This procedure installs an alarm expansion panel (AEP) onto the 15454-SA-ANSI or 15454-SA-HD shelf backplane. The AEP provides alarm contacts in addition to the 16 provided by the AIC-I card. Typically, the AEP is preinstalled when ordered with the ONS 15454; however, the AEP can be ordered separately. The AIC-I card must be installed before you can provision the alarm contacts enabled by the AEP.
Tools/Equipment	#2 Phillips screwdriver Medium slot-head screwdriver Small slot-head screwdriver Wire wrapper Standoffs (4)
Prerequisite Procedures	DLP-A10 Remove the Lower Backplane Cover, page 17-10
Required/As Needed	As needed
Onsite/Remote	Onsite
Security Level	None

Note

The AIC-I card provides direct alarm contacts (external alarm inputs and external control outputs). In the ANSI shelf, these AIC-I alarm contacts are routed through the backplane to wire-wrap pins accessible from the back of the shelf. When you install an AEP, the direct AIC-I alarm contacts cannot be used. Only the AEP alarm contacts can be used.

-
- Step 1** Remove the two backplane screws. Replace the two screws with standoffs. Insert the longer standoff on the left and the shorter standoff on the right ([Figure 1-2](#)).

Figure 1-2 Replace Backplane Screws with Standoffs

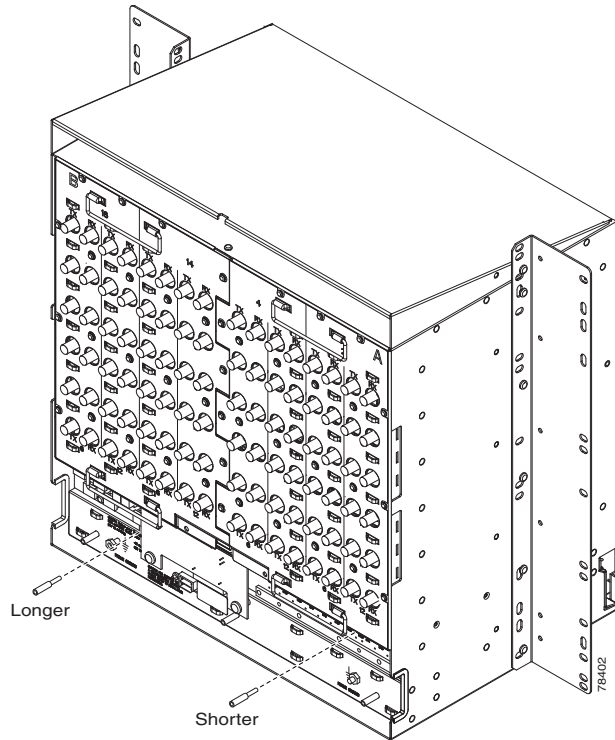

Step 2 Attach the remaining two standoffs on either side of the backplane ([Figure 1-3](#)).

Step 3 Position the AEP board over the standoffs.

Figure 1-3 *Installing Standoffs and the AEP*

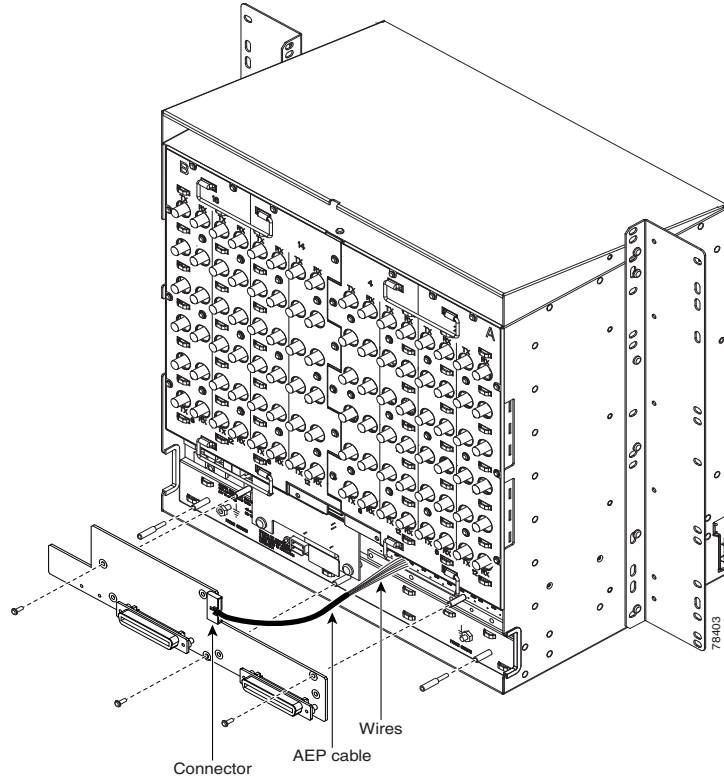

- Step 4** Insert and tighten three screws to secure the AEP to the backplane.
- Step 5** Connect the AEP cable to the backplane and AEP:
- a. Connect the 10 colored wires to the wire-wrap pins on the backplane. [Figure 1-4](#) shows where the cable wires are connected. [Table 1-1](#) shows AEP and AIC-I signals that each wire carries.
 - b. Plug the other end of the AEP cable into AEP connector port. The brown pin is on the top.

Figure 1-4 *AEP Wire-Wrap Connections to Backplane Pins*

Table 1-1 Pin Assignments for the AEP

AEP Cable Wire	Backplane Pin	AIC-I Signal	AEP Signal
Black	A1	GND	AEP_GND
White	A2	AE_+5	AEP_+5
Slate	A3	VBAT-	VBAT-
Violet	A4	VB+	VB+
Blue	A5	AE_CLK_P	AE_CLK_P
Green	A6	AE_CLK_N	AE_CLK_N
Yellow	A7	AE_DIN_P	AE_DOUT_P
Orange	A8	AE_DIN_N	AE_DOUT_N
Red	A9	AE_DOUT_P	AE_DIN_P
Brown	A10	AE_DOUT_N	AE_DIN_N

Step 6 Continue with the “[NTP-A8 Attach Wires to Alarm, Timing, LAN, and Craft Pin Connections](#)” procedure on page 1-16.

Stop. You have completed this procedure.

NTP-A8 Attach Wires to Alarm, Timing, LAN, and Craft Pin Connections

Purpose	This procedure describes how to install alarm, timing, LAN, and craft wires.
Tools/Equipment	Wire wrapper #22 or #24 AWG (0.51 mm ² or 0.64 mm ²) alarm wires
Prerequisite Procedures	NTP-A4 Remove the Backplane Covers, page 1-7
Required/As Needed	As needed
Onsite/Remote	Onsite
Security Level	None



Warning

The covers are an integral part of the safety design of the product. Do not operate the unit without the covers installed. Statement 1077

- Step 1** Complete the “[DLP-A19 Install Alarm Wires on the Backplane](#)” task on page 17-21 if you are using an AIC-I card and are not using an AEP.
- Step 2** Complete the “[DLP-A20 Install Timing Wires on the Backplane](#)” task on page 17-25 as needed. Timing wires are necessary to provision external timing.
- Step 3** Complete the “[DLP-A21 Install LAN Wires on the Backplane](#)” task on page 17-26 as needed. LAN wires (or the LAN port on the TCC2/TCC2P) are necessary to create an external LAN connection.

- Step 4** Complete the “[DLP-A22 Install the TL1 Craft Interface](#)” task on page 17-27 as needed. Craft wires (or the EIA/TIA-232 port on the TCC2/TCC2P) are required to access TL1 using the craft interface.



Caution Always use the supplied ESD wristband when working with a powered ONS 15454. Plug the wristband cable into the ESD jack located on the lower-right outside edge of the shelf assembly.

- Step 5** Complete one of the following:
- If you installed an AEP, continue with the “[NTP-A120 Install an External Wire-Wrap Panel to the AEP](#)” procedure on page 1-17.
 - If you did not install an AEP and you plan to install electrical cards, continue with the “[NTP-A9 Install the Electrical Card Cables on the Backplane](#)” procedure on page 1-22.
 - If you did not install an AEP and do not plan to install electrical cards, continue with the “[NTP-A11 Install the Rear Cover](#)” procedure on page 1-23.

Stop. You have completed this procedure.

NTP-A120 Install an External Wire-Wrap Panel to the AEP

Purpose	This procedure connects an external wire-wrap panel to the AEP to provide the physical alarm contacts for the AEP.
Tools/Equipment	External wire-wrap panel
Prerequisite Procedures	NTP-A119 Install the Alarm Expansion Panel, page 1-13
Required/As Needed	As needed
Onsite/Remote	Onsite
Security Level	None

- Step 1** Position the lower cover over the AEP. Make sure that the AEP AMP Champ connectors protrude through the cutouts in the lower cover ([Figure 1-5](#)).

Figure 1-5 Installing the AEP Cover

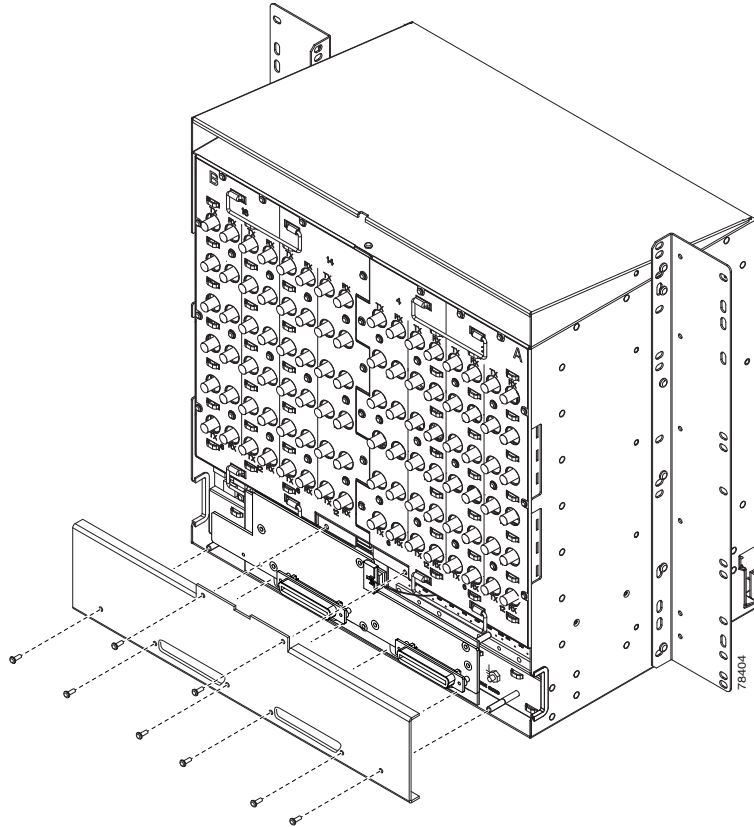

- Step 2** Insert and tighten the eight screws to secure the AEP cover to the AEP.
- Step 3** Connect the cables from the external wire-wrap panel to the AMP Champ connectors on the AEP. [Table 1-2](#) lists the alarm input pin assignments.

Table 1-2 Alarm Input Pin Assignments

AMP Champ Pin	Signal Name	AMP Champ Pin	Signal Name
1	ALARM_IN_1-	27	GND
2	GND	28	ALARM_IN_2-
3	ALARM_IN_3-	29	ALARM_IN_4-
4	ALARM_IN_5-	30	GND
5	GND	31	ALARM_IN_6-
6	ALARM_IN_7-	32	ALARM_IN_8-
7	ALARM_IN_9-	33	GND
8	GND	34	ALARM_IN_10-
9	ALARM_IN_11-	35	ALARM_IN_12-
10	ALARM_IN_13-	36	GND
11	GND	37	ALARM_IN_14-
12	ALARM_IN_15-	38	ALARM_IN_16-

Table 1-2 Alarm Input Pin Assignments (continued)

AMP Champ Pin	Signal Name	AMP Champ Pin	Signal Name
13	ALARM_IN_17-	39	GND
14	GND	40	ALARM_IN_18-
15	ALARM_IN_19-	41	ALARM_IN_20-
16	ALARM_IN_21-	42	GND
17	GND	43	ALARM_IN_22-
18	ALARM_IN_23-	44	ALARM_IN_24-
19	ALARM_IN_25-	45	GND
20	GND	46	ALARM_IN_26-
21	ALARM_IN_27-	47	ALARM_IN_28-
22	ALARM_IN_29-	48	GND
23	GND	49	ALARM_IN_30-
24	ALARM_IN_31-	50	—
25	ALARM_IN_+	51	GND1
26	ALARM_IN_0-	52	GND2

Table 1-3 lists the alarm output pin assignments.

Table 1-3 Alarm Output Pin Assignments

AMP Champ Pin	Signal Name	AMP Champ Pin	Signal Name
1	—	27	COM_0
2	COM_1	28	—
3	NO_1	29	NO_2
4	—	30	COM_2
5	COM_3	31	—
6	NO_3	32	NO_4
7	—	33	COM_4
8	COM_5	34	—
9	NO_5	35	NO_6
10	—	36	COM_6
11	COM_7	37	—
12	NO_7	38	NO_8
13	—	39	COM_8
14	COM_9	40	—
15	NO_9	41	NO_10
16	—	42	COM_10
17	COM_11	43	—

Table 1-3 Alarm Output Pin Assignments (continued)

AMP Champ Pin	Signal Name	AMP Champ Pin	Signal Name
18	NO_11	44	NO_12
19	—	45	COM_12
20	COM_13	46	—
21	NO_13	47	NO_14
22	—	48	COM_14
23	COM_15	49	—
24	NO_15	50	—
25	—	51	GND1
26	NO_0	52	GND2

Figure 1-6 illustrates the alarm input connectors.

Figure 1-6 Alarm Input Connector

Figure 1-7 illustrates the alarm output connectors.

Figure 1-7 Alarm Output Connector

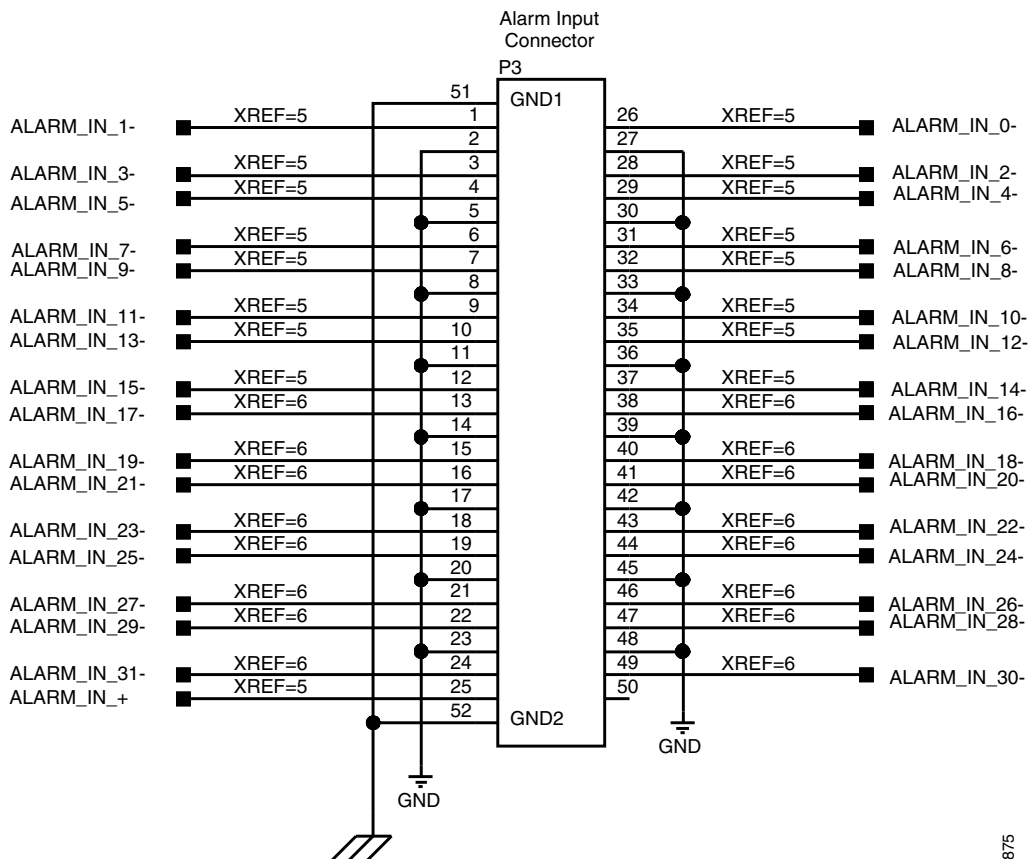
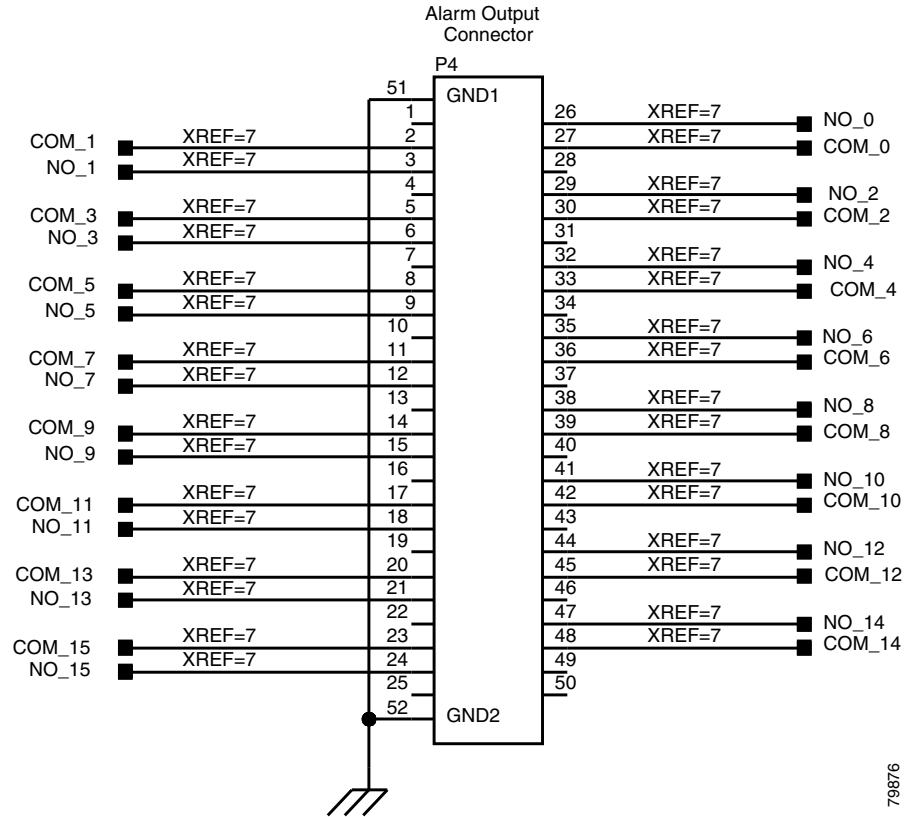

79876

Step 4 Complete one of the following:

- If you plan to install electrical cards, continue with the “[NTP-A9 Install the Electrical Card Cables on the Backplane](#)” procedure on page 1-22.
- If you do not plan to install electrical cards, continue with the “[NTP-A11 Install the Rear Cover](#)” procedure on page 1-23.

Stop. You have completed this procedure.

NTP-A9 Install the Electrical Card Cables on the Backplane

Purpose	Optional EIA backplane covers are typically preinstalled when ordered with the ONS 15454. The following procedure describes how to install the electrical card cables to the backplane. If the shelf was not shipped with the correct EIA interface, you must order and install the correct EIA.
Tools/Equipment	Wire wrapper Twisted-pair cables BNC insertion tool SMB cable connector #2 Phillips screwdriver Medium slot-head screwdriver DS-1 and DS-3 cables, as needed Tie-down bar, as needed
Prerequisite Procedures	NTP-A5 Install the EIAs, page 1-7
Required/As Needed	As needed
Onsite/Remote	Onsite
Security Level	None

Caution

Always use the supplied ESD wristband when working with a powered ONS 15454. Plug the wristband cable into the ESD jack located on the lower-right outside edge of the shelf assembly.

Note

Refer to the *Cisco ONS 15454 Reference Manual* for more information about EIAs.

-
- Step 1** Complete the [“DLP-A530 Install the Tie-Down Bar”](#) task on page 22-29 as needed for routing the electrical cables you will install.
- Step 2** Complete the [“DLP-A23 Install DS-1 Cables Using Electrical Interface Adapters \(Balun\)”](#) task on page 17-28 as needed. Baluns are used on SMB EIAs to properly terminate DS-1 signals.
- Step 3** To install DS-1 cables using AMP Champ cables, complete the [“DLP-A24 Install DS-1 AMP Champ Cables on the AMP Champ EIA”](#) task on page 17-29.
- Step 4** Complete the [“DLP-A25 Install Coaxial Cable With BNC Connectors”](#) task on page 17-32 as needed.
- Step 5** Complete the [“DLP-A26 Install Coaxial Cable With High-Density BNC Connectors”](#) task on page 17-33 as needed.
- Step 6** Complete the [“DLP-A27 Install Coaxial Cable with SMB Connectors”](#) task on page 17-33 as needed.
- Step 7** Complete the [“DLP-A386 Install Electrical Cables on the UBIC-V EIAs”](#) task on page 20-83 as needed.
- Step 8** Complete the [“DLP-A441 Install Electrical Cables on the UBIC-H EIAs”](#) task on page 21-22 as needed.
- Step 9** Continue with the [“NTP-A10 Route Electrical Cables”](#) procedure on page 1-23.

Stop. You have completed this procedure.

NTP-A10 Route Electrical Cables

Purpose	This procedure routes and manages electrical (backplane) cables.
Tools/Equipment	RG179, RG59 (735A) #26 AWG cable, or RG59 (734A) #20 AWG cable
Prerequisite Procedures	NTP-A9 Install the Electrical Card Cables on the Backplane, page 1-22
Required/As Needed	As needed
Onsite/Remote	Onsite
Security Level	None

-
- Step 1** Complete the “[DLP-A28 Route Coaxial Cables](#)” task on page 17-35 as needed.
- Step 2** Complete the “[DLP-A29 Route DS-1 Twisted-Pair Cables](#)” task on page 17-36 as needed.
- Step 3** Continue with the “[NTP-A11 Install the Rear Cover](#)” procedure on page 1-23.
- Stop. You have completed this procedure.**
-

NTP-A11 Install the Rear Cover

Purpose	This procedure explains how to install the rear cover.
Tools/Equipment	#2 Phillips screwdriver 5/16-inch nut driver Shelf accessory kit (53-2329-XX) <ul style="list-style-type: none"> • Two mounting bars (700-19701-XX) • Four 1-inch standoffs (50-1193-01) • Four 1 3/8-inch standoffs (50-1492-01) • Eight 2-inch standoffs (50-1453-01) • Four flathead screws, 6-32 x 0.5 (48-2116-01) Plastic rear cover (700-06029-XX)
Prerequisite Procedures	NTP-A3 Open and Remove the Front Door, page 1-6
Required/As Needed	Required
Onsite/Remote	Onsite
Security Level	None

-
- Step 1** Identify the EIA type where you will install the rear cover.
- Step 2** According to [Table 1-4](#), assemble the extended standoffs for that EIA type. Start with a 1 3/8-inch standoff and attach the other standoff(s) to that standoff to create an extended standoff. You should assemble two extended standoffs for each side, for a total of four extended standoffs per shelf.

Table 1-4 Standoffs Required for EIA Types

EIA Type	Required Standoffs for One Extended Standoff	Total Required Standoffs per Shelf
UBIC-V	One 1 3/8-inch Two 2-inch	Four 1 3/8-inch Eight 2-inch
UBIC-H	One 1 3/8-inch One 2-inch	Four 1 3/8-inch Four 2-inch
MiniBNC	One 1 3/8-inch One 2-inch	Four 1 3/8-inch Four 2-inch
BNC	One 1 3/8-inch	Four 1 3/8-inch
High-Density BNC	One 1-inch	Four 1-inch
SMB		
AMP Champ		



Note As needed, attach additional standoffs to the extended standoffs to meet site-specific cable management requirements.

- Step 3** Locate the mounting holes where you will install the standoffs on the EIAs you are using. [Figure 1-8](#) shows the mounting holes on the UBIC-V. [Figure 1-9](#) shows the mounting holes on the UBIC-H. [Figure 1-10](#) shows the mounting holes on the remaining EIA types (MiniBNC, SMB, etc.). You can identify the mounting holes on all EIAs by locating the *REAR COVER BRACKET LOCATION* designation.

Figure 1-8 Mounting Holes on the UBIC-V EIA

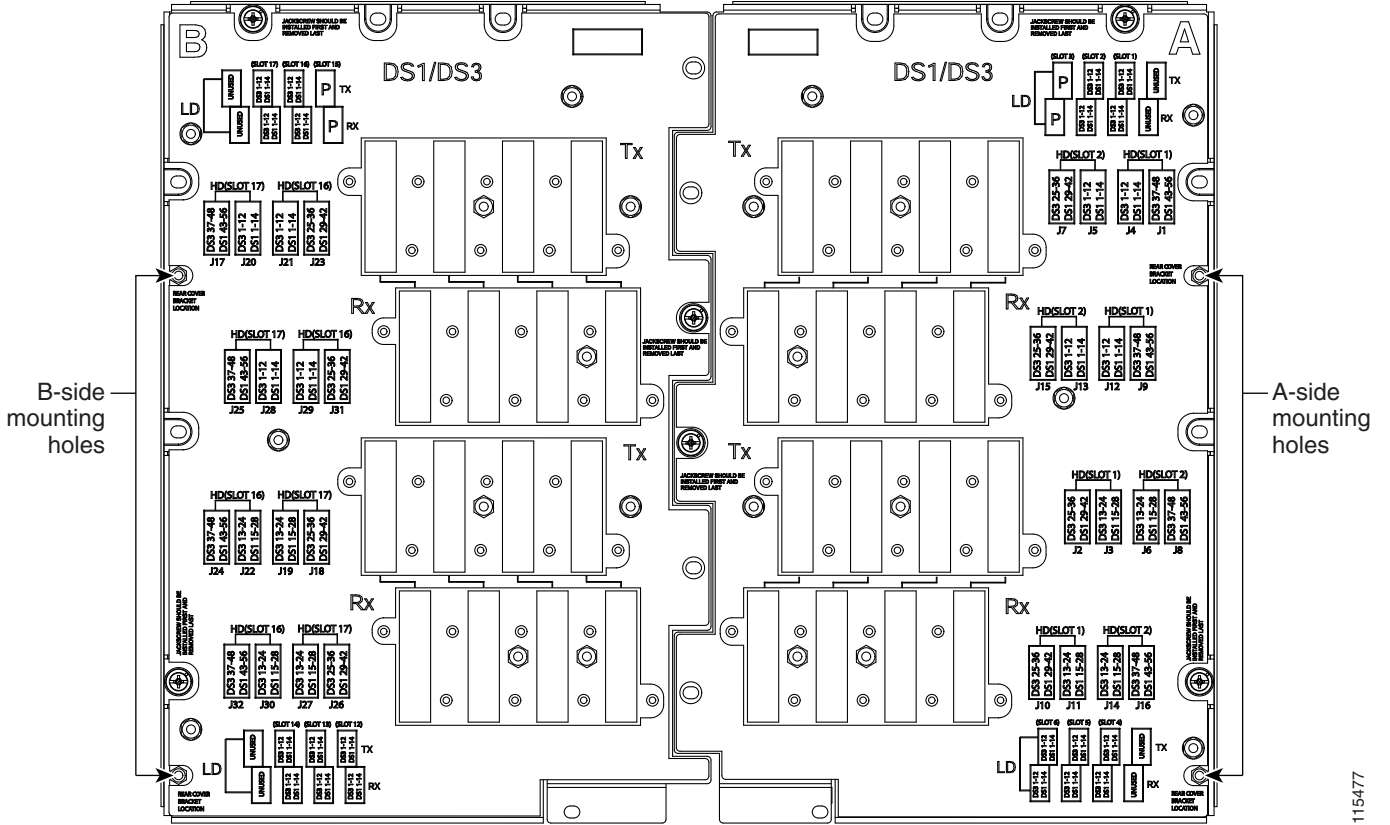

115477

Figure 1-9 Mounting Holes on the UBIC-H

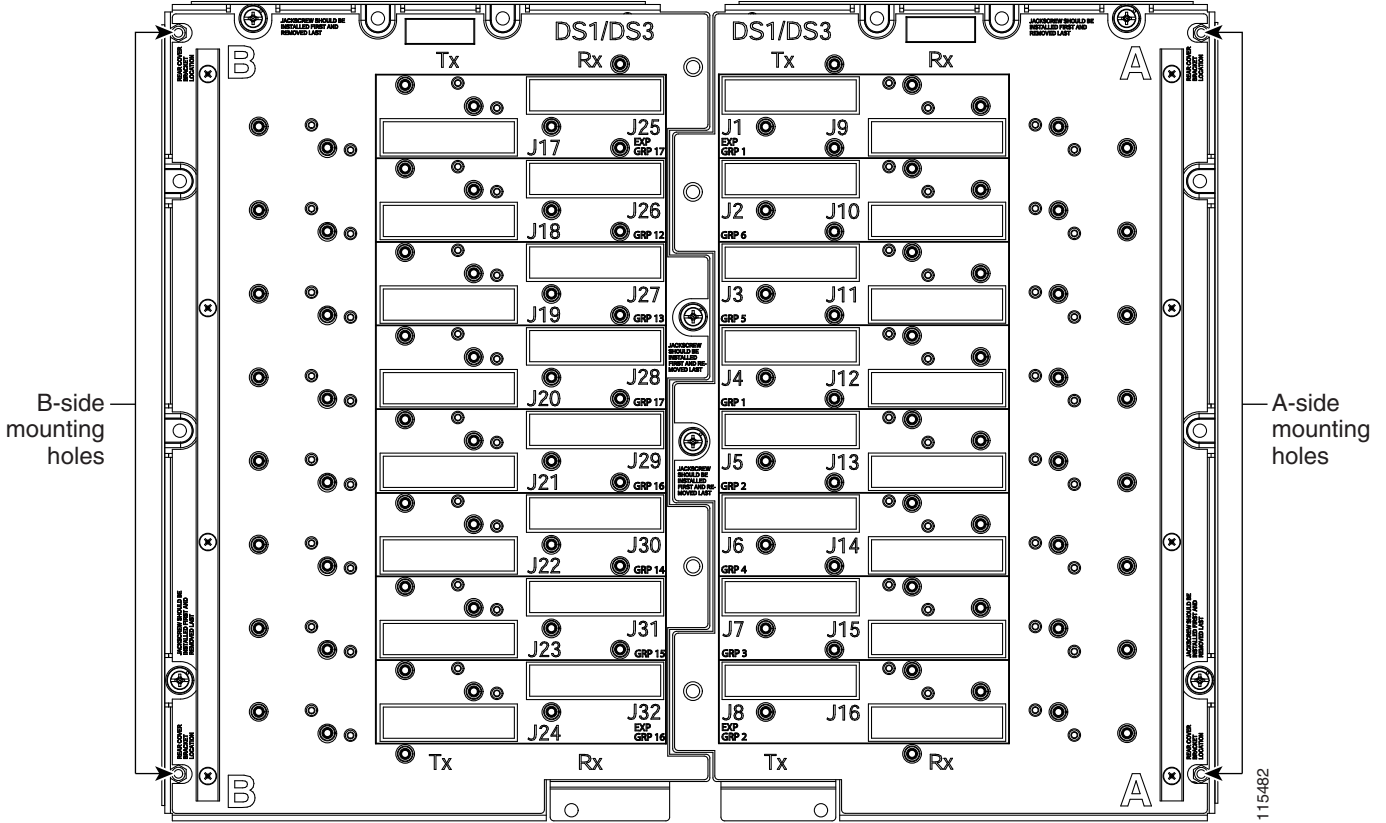
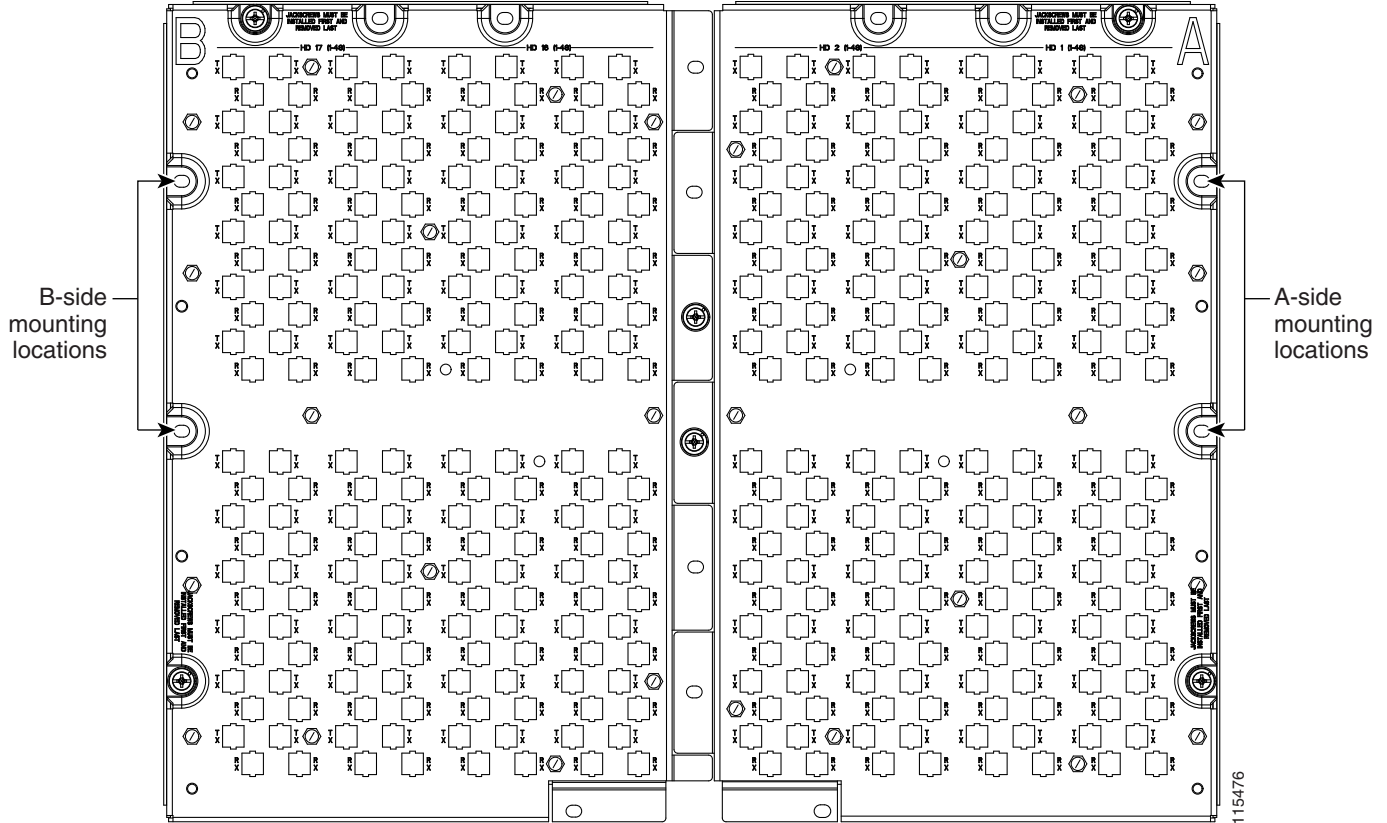
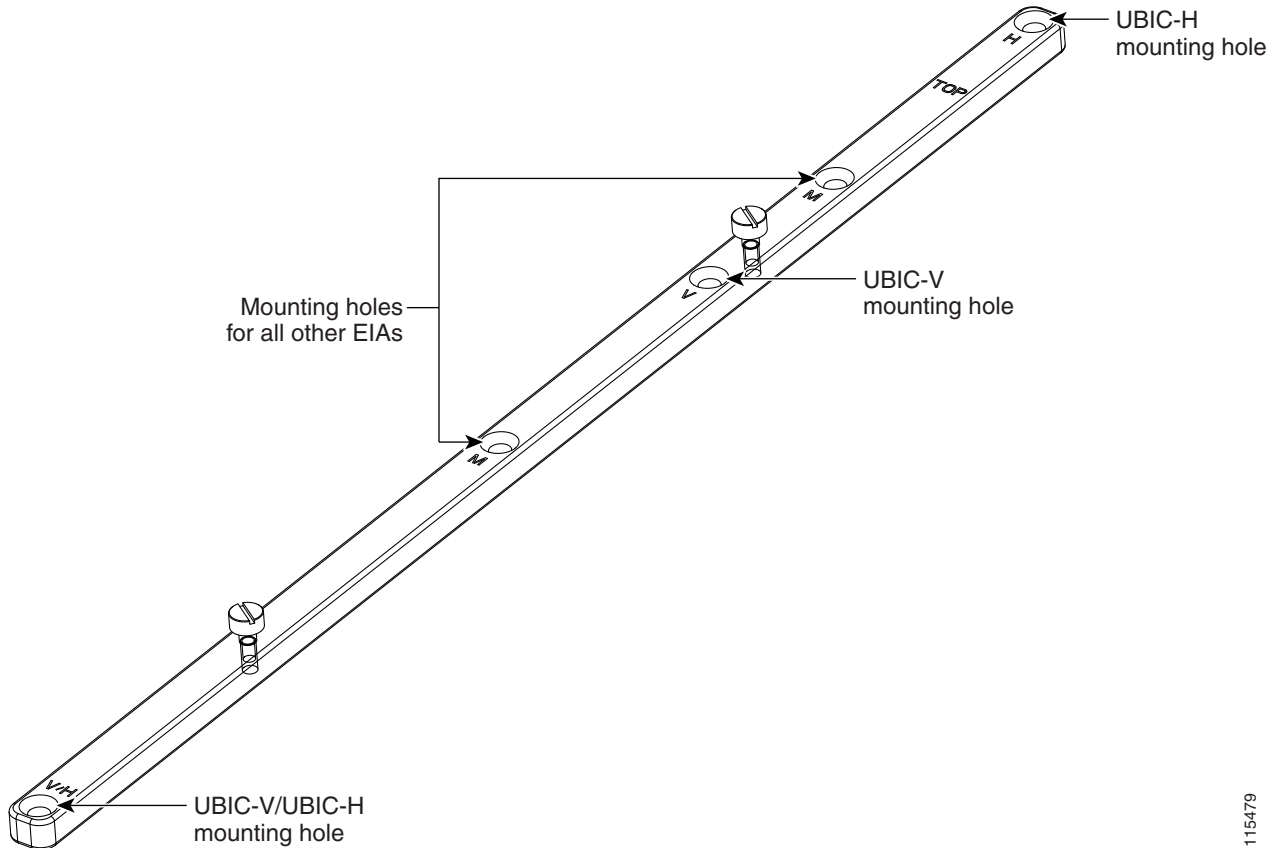

Figure 1-10 Mounting Holes on All Other EIA Types



- Step 4** Use a 5/16-inch nutdriver to install the extended standoffs in the mounting holes.
- Step 5** Locate the *TOP* designation on one of the mounting bars (700-19701-XX) and align the appropriate holes for your EIA with the extended standoffs (Figure 1-11).

Figure 1-11 EIA Labelling on the Mounting Bar



115479

- Step 6** Tighten the two screws (48-2116-01) for each mounting bar.
- Step 7** Repeat Steps 5 and 6 for the second mounting bar.
- Step 8** Attach the rear cover (700-06029-XX) by hanging it from the mounting screws on the back of the mounting bars and pulling it down until it fits firmly into place (Figure 1-12) or by using standoffs (Figure 1-13).

Figure 1-12 Installing the Rear Cover Onto the Mounting Bars

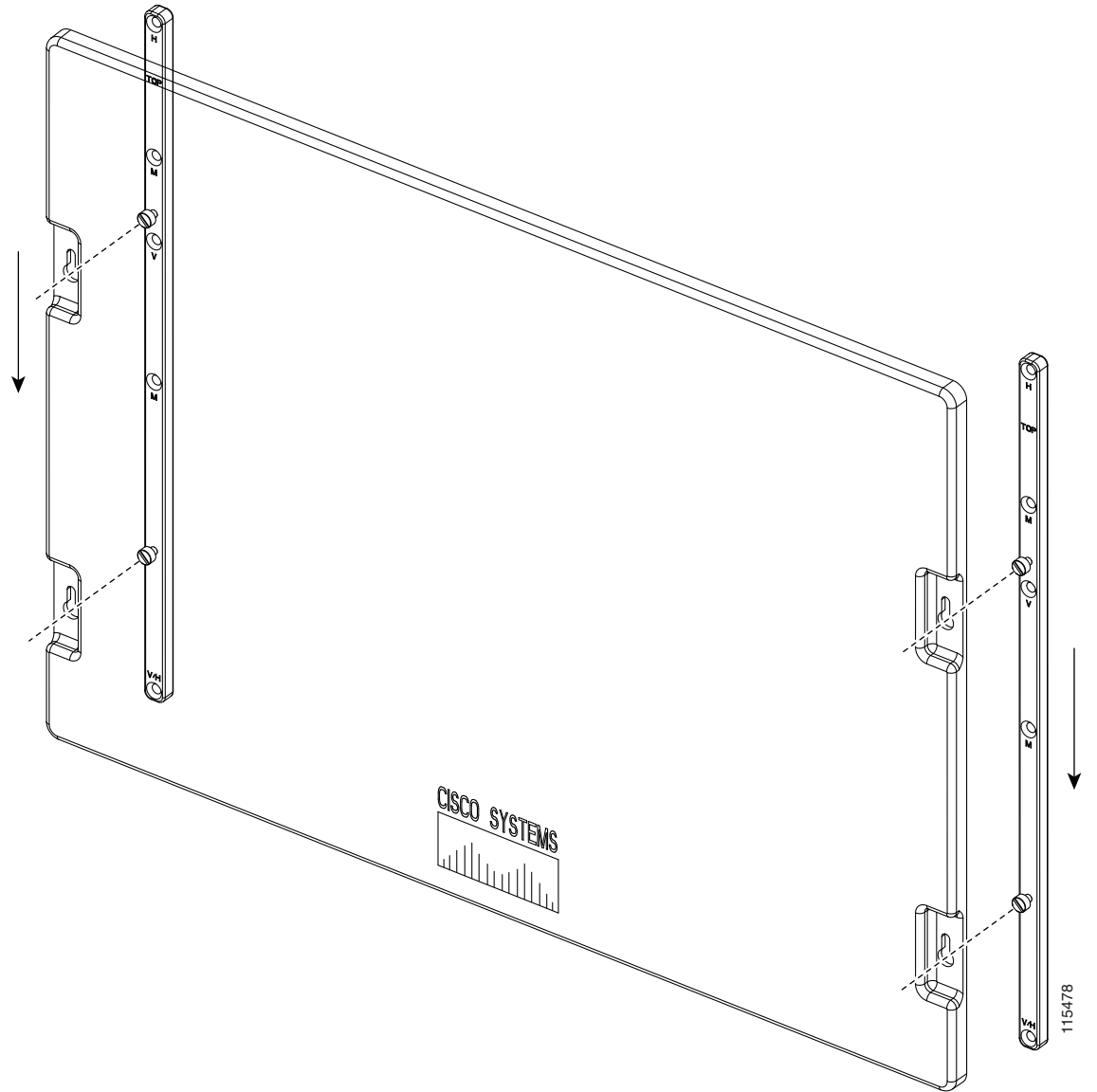
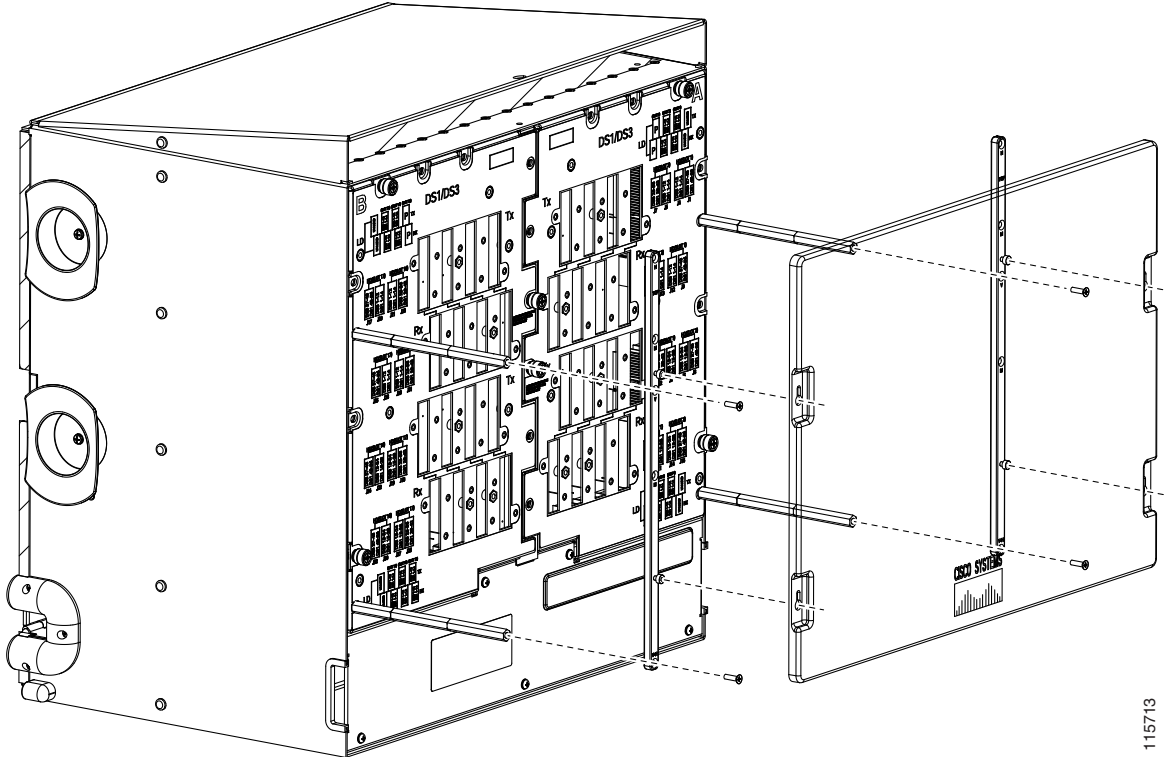

Figure 1-13 Installing the Rear Cover with Standoffs



Stop. You have completed this procedure.

NTP-A13 Perform the Shelf Installation Acceptance Test

Purpose	Use this procedure to perform a shelf installation acceptance test.
Tools/Equipment	Voltmeter
Prerequisite Procedures	Applicable procedures in Chapter 1
Required/As Needed	Required
Onsite/Remote	Onsite
Security Level	None



Warning

The covers are an integral part of the safety design of the product. Do not operate the unit without the covers installed.

Step 1 Complete [Table 1-5](#) by verifying that each applicable procedure was completed.

Table 1-5 Shelf Installation Task Summary

Description	Completed
NTP-A1 Unpack and Inspect the ONS 15454 Shelf Assembly, page 1-4	
NTP-A2 Install the Shelf Assembly, page 1-5	
NTP-A3 Open and Remove the Front Door, page 1-6	
NTP-A4 Remove the Backplane Covers, page 1-7	
NTP-A5 Install the EIAs, page 1-7	
NTP-A6 Install the Power and Ground, page 1-9	
NTP-A7 Install the Fan-Tray Assembly, page 1-10	
NTP-A119 Install the Alarm Expansion Panel, page 1-13	
NTP-A8 Attach Wires to Alarm, Timing, LAN, and Craft Pin Connections, page 1-16	
NTP-A120 Install an External Wire-Wrap Panel to the AEP, page 1-17	
NTP-A9 Install the Electrical Card Cables on the Backplane, page 1-22	
NTP-A10 Route Electrical Cables, page 1-23	
NTP-A11 Install the Rear Cover, page 1-23	

Step 2 Complete the “DLP-A32 Inspect the Shelf Installation and Connections” task on page 17-37.

Step 3 Complete the “DLP-A33 Measure Voltage” task on page 17-37.

Step 4 Continue with Chapter 2, “Install Cards and Fiber-Optic Cable.”

Stop. You have completed this procedure.

