



Network Reference

This chapter explains the ONS 15454 dense wavelength division multiplexing (DWDM) network applications and topologies. The chapter also provides network-level optical performance references.



Note

Unless otherwise specified, “ONS 15454” refers to both ANSI and ETSI shelf assemblies.



Note

Unless otherwise specified, OPT-BST refers to the OPT-BST, OPT-BST-E, and OPT-BST-L cards, 32WSS refers to the 32WSS and 32WSS-L cards, and 32DMX refers to the 32DMX and 32DMX-L cards (not including the 32DMX-O card). OPT-PRE refers to both the OPT-PRE card and the OPT-AMP-L card provisioned in OPT-Line mode.



Note

OPT-BST-L, 32WSS-L, 32DMX-L, and OPT-AMP-L cards can only be installed in L-band compatible nodes and networks. OPT-BST, OPT-BST-E, 32WSS, and 32DMX, cards can only be installed in C-band compatible nodes and networks.

Chapter topics include:

- [4.1 Network Applications, page 4-2](#)
- [4.2 Network Topologies, page 4-2](#)
- [4.3 Optical Performance, page 4-7](#)
- [4.4 Automatic Power Control, page 4-8](#)
- [4.5 ROADM Power Equalization Monitoring, page 4-12](#)
- [4.6 Span Loss Verification, page 4-13](#)
- [4.7 Network Optical Safety—Automatic Laser Shutdown, page 4-14](#)
- [4.8 Network-Level Gain—Tilt Management of Optical Amplifiers, page 4-23](#)
- [4.9 Optical Channel Circuits, page 4-29](#)

4.1 Network Applications

Cisco ONS 15454s can be provisioned for metro access and metro core DWDM network applications. Metro access networks are 60 km or less in size. Channels are not equalized and dispersion compensation is not applied. Metro access networks have few spans and very low span loss, so the signal link budget is the limiting factor for performance. Metro core networks can be up to 400 km in size. The channel power is equalized and dispersion compensation is applied. Metro core networks often include multiple spans and amplifiers, so the optical signal-to-noise ratio (OSNR) is the limiting factor for channel performance in metro core networks.

Within DWDM networks, the ONS 15454 uses a communications protocol, called node services protocol (NSP), to communicate with other nodes. NSP automatically updates nodes whenever a change in the network occurs. Each ONS 15454 DWDM node can:

- Identify other ONS 15454 DWDM nodes in the network.
- Identify the different types of DWDM networks.
- Identify when the DWDM network is complete and when it is incomplete.

4.2 Network Topologies

The ONS 15454 DWDM network topologies include hubbed, multihubbed, and meshed rings, and linear and single-span networks.

4.2.1 Hubbed Rings

In the hubbed ring topology ([Figure 4-1](#)), a hub node terminates all the DWDM channels. A channel can be provisioned to support protected traffic between the hub node and any node in the ring. Both working and protected traffic use the same wavelength on both sides of the ring. Protected traffic can also be provisioned between any pair of optical add/drop multiplexing (OADM) nodes, except that either the working or the protected path must be regenerated in the hub node.

Protected traffic saturates a channel in a hubbed ring, that is, no channel reuse is possible. However, the same channel can be reused in different sections of the ring by provisioning unprotected multihop traffic. From a transmission point of view, this network topology is similar to two bidirectional point-to-point links with OADM nodes.

For more information about hub nodes, see the [“3.1.1 Hub Node”](#) section on page 3-2.

Figure 4-1 Hubbed Ring

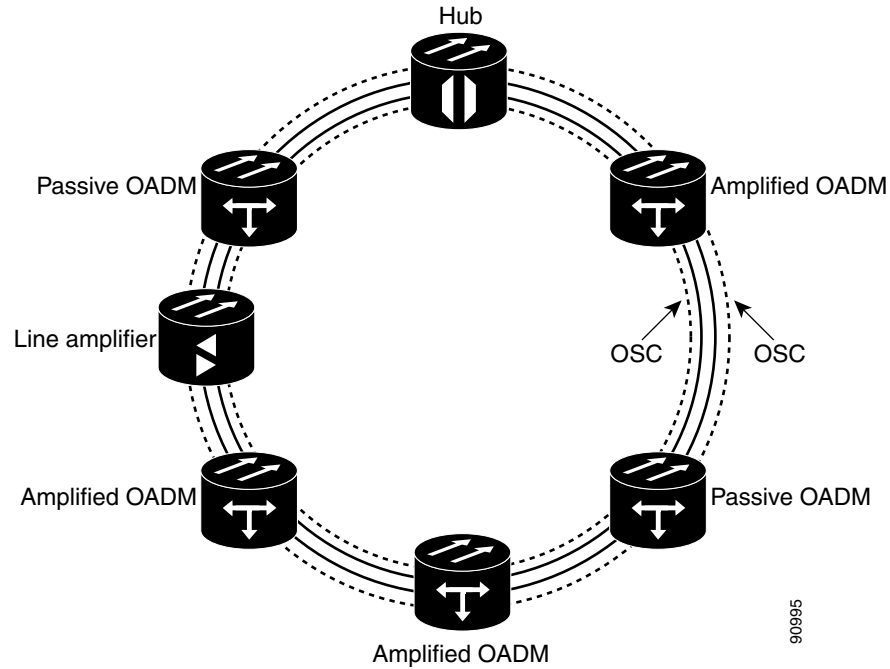

90905

4.2.2 Multihubbed Rings

A multihubbed ring (Figure 4-2) is based on the hubbed ring topology, except that two or more hub nodes are added. Protected traffic can only be established between the two hub nodes. Protected traffic can be provisioned between a hub node and any OADM node only if the allocated wavelength channel is regenerated through the other hub node. Multihop traffic can be provisioned on this ring. From a transmission point of view, this network topology is similar to two or more point-to-point links with OADM nodes.

Figure 4-2 Multihubbed Ring

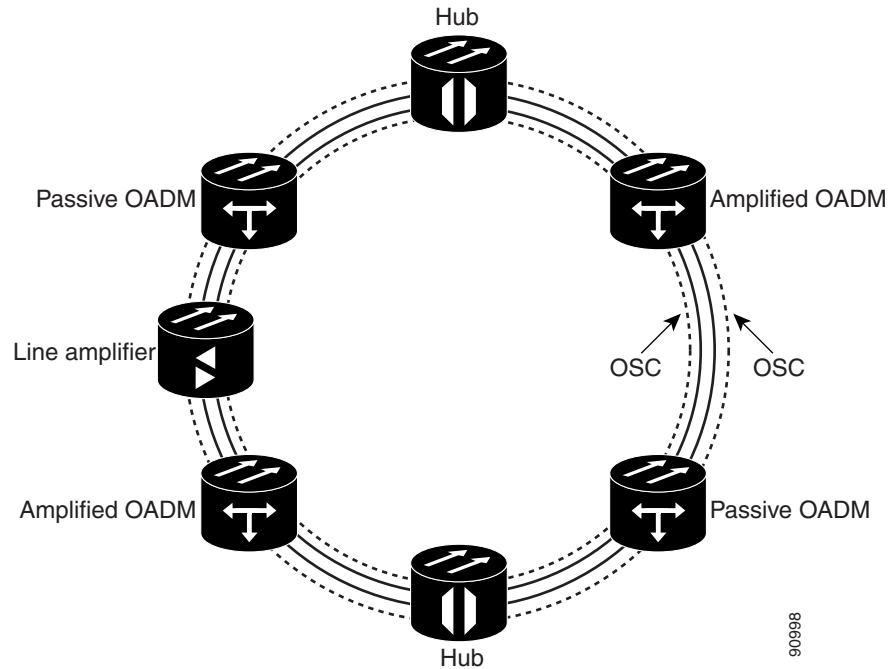

4.2.3 Any-to-Any Rings

The any-to-any ring topology (Figure 4-3) contains only reconfigurable OADM (ROADM) nodes, or ROADM nodes with optical service channel (OSC) regeneration or amplifier nodes. This topology potentially allows you to route every wavelength from any source to any destination node inside the network.

See the “3.1.4 ROADM Node” section on page 3-8 for more information.

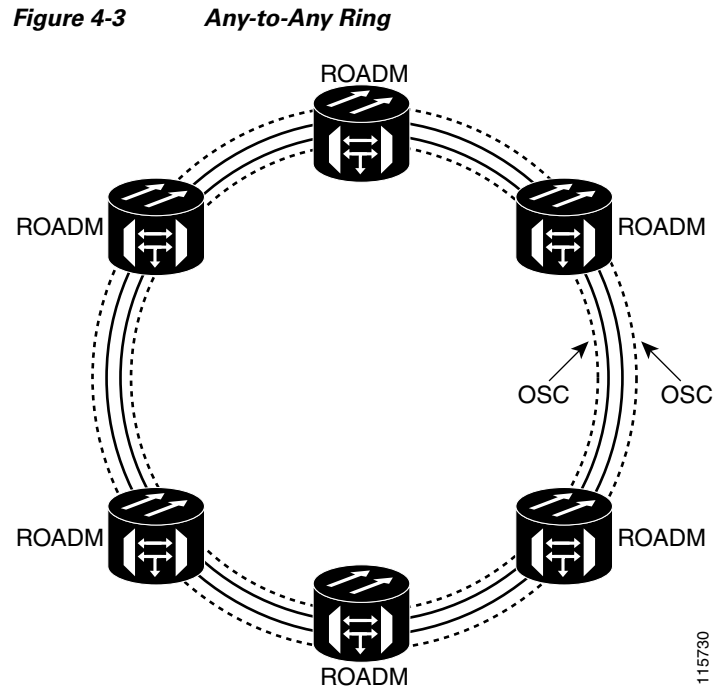

4.2.4 Meshed Rings

The meshed ring topology (Figure 4-4) does not use hubbed nodes; only amplified and passive OADM nodes are present. Protected traffic can be provisioned between any two nodes; however, the selected channel cannot be reused in the ring. Unprotected multihop traffic can be provisioned in the ring. A meshed ring must be designed to prevent amplified spontaneous emission (ASE) lasing. This is done by configuring a particular node as an anti-ASE node. An anti-ASE node can be created in two ways:

- Equip an OADM node with 32MUX-O cards and 32DMX-O cards. This solution is adopted when the total number of wavelengths deployed in the ring is higher than ten. OADM nodes equipped with 32MUX-O cards and 32DMX-O cards are called full OADM nodes.
- When the total number of wavelengths deployed in the ring is lower than ten, the anti-ASE node is configured by using an OADM node where all the channels that are not terminated in the node are configured as “optical pass-through.” In other words, no channels in the anti-ASE node can travel through the express path of the OADM node.

For more information about OADM nodes, see the “3.1.3 OADM Node” section on page 3-4. For more information about anti-ASE nodes, see the “3.1.5 Anti-ASE Node” section on page 3-11.

Figure 4-4 Meshed Ring

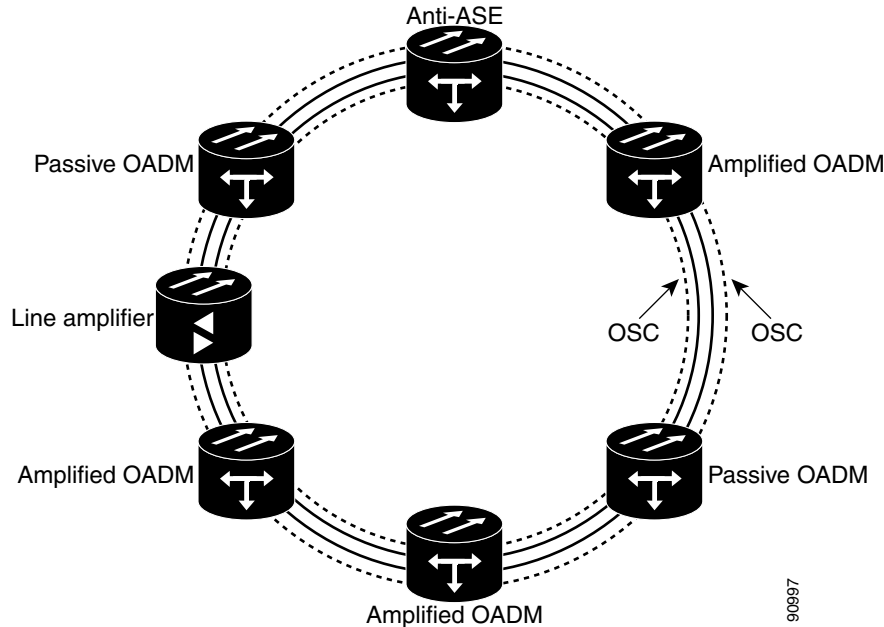

4.2.5 Linear Configurations

Linear configurations are characterized by the use of two terminal nodes (west and east). The terminal nodes can be equipped with a 32MUX-O card and a 32DMX-O card, or a 32WSS card with a 32DMX or 32DMX-O card. OADM or line amplifier nodes can be installed between the two terminal nodes. Only unprotected traffic can be provisioned in a linear configuration. Figure 4-5 shows five ONS 15454 nodes in a linear configuration with an amplified and a passive OADM node.

Figure 4-5 Linear Configuration with an OADM Node

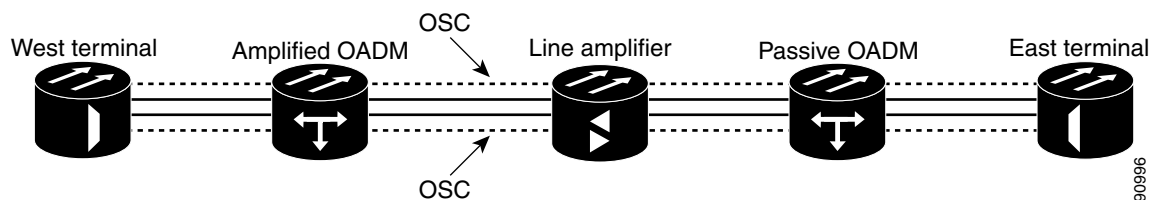
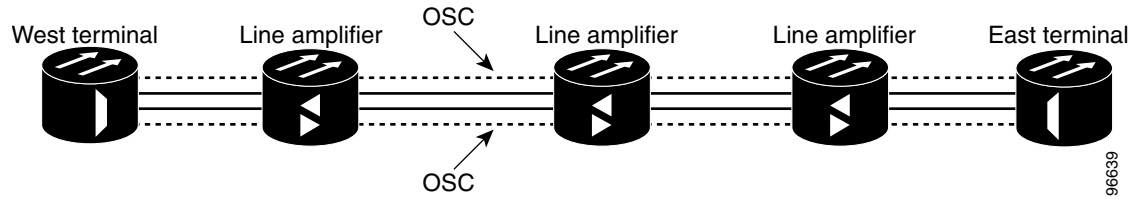

Figure 4-6 shows five ONS 15454 nodes in a linear configuration without an OADM node.

See the “3.1.2 Terminal Node” section on page 3-3 for more information.

Figure 4-6 Linear Configuration without an OADM Node

4.2.6 Single-Span Link

Single-span link is a type of linear configuration characterized by a single-span link with pre-amplification and post-amplification. A single-span link is also characterized by the use of two terminal nodes (west and east). The terminal nodes are usually equipped with a 32MUX-O card and a 32DMX-O card. However, a 32WSS card and a 32DMX or a 32DMX-O card can be installed. Software Release 4.7 and later also supports single-span links with AD-4C-xx.x cards. Only unprotected traffic can be provisioned on a single-span link.

Figure 4-7 shows ONS 15454s in a single-span link. Eight channels are carried on one span. Single-span link losses apply to OC-192 LR ITU cards. The optical performance values are valid assuming that the sum of the OADM passive node insertion losses and the span losses does not exceed 35 dB.

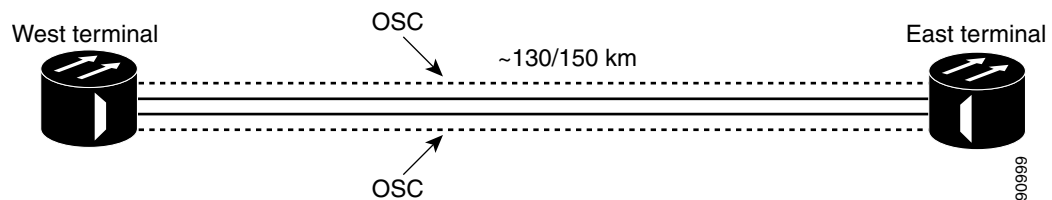
Figure 4-7 Single-Span Link

4.3 Optical Performance

This section provides optical performance information for ONS 15454 DWDM networks. The performance data is a general guideline based upon the network topology, node type, client cards, fiber type, number of spans, and number of channels. The maximum number of nodes that can be in an ONS 15454 DWDM network is 16. The DWDM topologies and node types that are supported are shown in Table 4-1.

Table 4-1 Supported Topologies and Node Types

Number of Channels	Fiber	Topologies	Node Type
32 channels	SMF-28 ¹	Ring	Hub
	E-LEAF ²	Linear	Active OADM
	TW-RS ³	Linear without OADM	Passive OADM Terminal Line OSC regeneration
16 channels	SMF-28	Ring	Hub
		Linear	Active OADM
		Linear without OADM	Passive OADM Terminal Line OSC regeneration
8 channels	SMF-28	Linear without OADM	Terminal Line

1. SMF-28 = single-mode fiber 28

2. E-LEAF = enhanced large effective area fiber

3. TW-RS = TrueWave reduced slope fiber

4.4 Automatic Power Control

The ONS 15454 automatic power control (APC) feature performs the following functions:

- Maintains constant per-channel power when changes to the number of channels occur.
- Compensates for optical network degradation (aging effects).
- Simplifies the installation and upgrade of DWDM optical networks by automatically calculating the amplifier setpoints.



Note

APC functions are performed by software algorithms on the OPT-BST, OPT-PRE, and TCC2/TCC2P cards.

Amplifier software uses a control gain loop with fast transient suppression to keep the channel power constant regardless of any changes in the number of channels. Amplifiers monitor the changes to the input power and change the output power according to the calculated gain setpoint. The shelf controller software emulates the control output power loop to adjust for fiber degradation. To perform this function, the TCC2/TCC2P needs to know the channel distribution, which is provided by a signaling protocol, and the expected per-channel power, which you can provision. The TCC2/TCC2P compares the actual amplifier output power with the expected amplifier output power and modifies the setpoints if any discrepancies occur.

4.4.1 APC at the Amplifier Card Level

In constant gain mode, the amplifier power out control loop performs the following input and output power calculations, where G represents the gain and t represents time.

$$P_{out}(t) = G * P_{in}(t) \text{ (mW)}$$

$$P_{out}(t) = G + P_{in}(t) \text{ (dB)}$$

In a power-equalized optical system, the total input power is proportional to the number of channels. The amplifier software compensates for any variation of the input power due to changes in the number of channels carried by the incoming signal.

Amplifier software identifies changes in the read input power in two different instances, t_1 and t_2 , as a change in the carried traffic. The letters m and n in the following formula represent two different channel numbers. P_{in}/ch represents the per-channel input power:

$$P_{in}(t_1) = nP_{in}/ch$$

$$P_{in}(t_2) = mP_{in}/ch$$

Amplifier software applies the variation in the input power to the output power with a reaction time that is a fraction of a millisecond. This keeps the power constant on each channel at the output amplifier, even during a channel upgrade or a fiber cut.

Amplifier parameters are configured using east and west conventions for ease of use. Selecting west provisions parameters for the preamplifier receiving from the west and the booster amplifier transmitting to the west. Selecting east provisions parameters for the preamplifier receiving from the east and the booster amplifier transmitting to the east.

Starting from the expected per-channel power, the amplifiers automatically calculate the gain setpoint after the first channel is provisioned. An amplifier gain setpoint is calculated in order to make it equal to the loss of the span preceding the amplifier itself. After the gain is calculated, the setpoint is no longer changed by the amplifier. Amplifier gain is recalculated every time the number of provisioned channels returns to zero. If you need to force a recalculation of the gain, move the number of channels back to zero.

4.4.2 APC at the Node and Network Levels

The amplifier adjusts the gain to compensate for span loss. Span loss changes due to aging fiber and components, or changes in operating conditions. To correct the gain or express variable optical attenuator (VOA) setpoints, APC calculates the difference between the power value read by the photodiodes and the expected power value. The expected power values are calculated using:

- Provisioned per-channel power value
- Channel distribution (the number of express, add, and drop channels in the node)
- ASE estimation

Channel distribution is determined by the sum of the provisioned and failed channels. Information about provisioned wavelengths is sent to APC on the applicable nodes during circuit creation. Information about failed channels is collected through a signaling protocol that monitors alarms on ports in the applicable nodes and distributes that information to all the other nodes in the network.

ASE calculations purify the noise from the power level reported from the photodiode. Each amplifier can compensate for its own noise, but cascaded amplifiers cannot compensate for ASE generated by preceding nodes. The ASE effect increases when the number of channels decreases; therefore, a correction factor must be calculated in each amplifier of the ring to compensate for ASE build-up.

APC is a network-level feature. The APC algorithm designates a master node that is responsible for starting APC hourly or every time a new circuit is provisioned or removed. Every time the master node signals for APC to start, gain and VOA setpoints are evaluated on all nodes in the network. If corrections are needed in different nodes, they are always performed sequentially following the optical paths starting from the master node.

APC corrects the power level only if the variation exceeds the hysteresis thresholds of ± 0.5 dB. Any power level fluctuation within the threshold range is skipped since it is considered negligible. Because APC is designed to follow slow time events, it skips corrections greater than 3 dB. This is the typical total aging margin that is provisioned during the network design phase. After you provision the first channel or the amplifiers are turned up for the first time, APC does not apply the 3 dB rule. In this case, APC corrects all the power differences to turn up the node.

To avoid large power fluctuations, APC adjusts power levels incrementally. The maximum power correction is ± 0.5 dB. This is applied to each iteration until the optimal power level is reached. For example, a gain deviation of 2 dB is corrected in four steps. Each of the four steps requires a complete APC check on every node in the network. APC can correct up to a maximum of 3 dB on an hourly basis. If degradation occurs over a longer time period, APC will compensate for it by using all margins that you provision during installation.

When no margin is available, adjustments cannot be made because setpoints exceed ranges. APC communicates the event to CTC, CTM, and TL1 through an APC Fail condition. APC will clear the APC fail condition when the setpoints return to the allowed ranges.

APC automatically disables itself when:

- A HW FAIL alarm is raised by any card in any of the network nodes.
- A Mismatch Equipment Alarm (MEA) is raised by any card in any of the network nodes.
- An Improper Removal (IMPROPRMVL) alarm is raised by any card in any of the network nodes.
- Gain Degrade (GAIN-HDEG), Power Degrade (OPWR-HDEG), and Power Fail (PWR-FAIL) alarms are raised by the output port of any amplifier card in any of the network nodes.
- A VOA degrade or fail alarm is raised by any of the cards in any of the network nodes.

The APC state (Enable/Disable) is located on every node and can be retrieved by the CTC or TL1 interfaces. If an event that disables APC occurs in one of the network nodes, APC is disabled on all the others and the APC state changes to DISABLE - INTERNAL. The disabled state is raised only by the node where the problem occurred to simplify troubleshooting.

APC raises the following standing conditions at the port level in CTC, TL1, and Simple Network Management Protocol (SNMP):

- APC Out of Range—APC cannot assign a new setpoint for a parameter this is allocated to a port because the new setpoint exceeds the parameter range.
- APC Correction Skipped—APC skipped a correction to one parameter allocated to a port because the difference between the expected and current values exceeds the ± 3 dB security range.

After the error condition is cleared, signaling protocol enables APC on the network and the APC DISABLE - INTERNAL condition is cleared. Because APC is required after channel provisioning to compensate for ASE effects, all optical channel network connection (OCHNC) and optical channel client connection (OCHCC) circuits that you provision during the disabled APC state are kept in the Out-of-Service and Autonomous, Automatic In-Service (OOS-AU,AINS) (ANSI) or Unlocked-disabled,automaticInService (ETSI) service state until APC is enabled. OCHNCs and OCHCCs automatically go into the In-Service and Normal (IS-NR) (ANSI) or Unlocked-enabled (ETSI) service state only after APC is enabled.

4.4.3 Managing APC

The automatic power control status is indicated by four APC states shown in the node view status area:

- Enable—APC is enabled.
- Disable - Internal—APC has been automatically disabled for an internal cause.
- Disable - User—APC was disabled manually by a user.
- Not Applicable—The node is provisioned to Metro Access or Not DWDM, which do not support APC.

You can view the automatic power control information and disable and enable APC manually on the Maintenance > DWDM > APC tab (Figure 4-8).



Caution

When APC is disabled, aging compensation is not applied and circuits cannot be activated. Do not disable APC unless it is required for specific maintenance or troubleshooting tasks. Always enable APC as soon as the tasks are completed.

Figure 4-8 Automatic Power Control

APC State

Position	Last Check	Parameter
Slot 14 (32 DMX L),Port 33 (COM-RX)	12/08/05 12:48:53 PST	Voa Target Attenuation
Slot 15 (OPT-AMP L),Port 6 (LINE-TX)	12/08/05 12:48:53 PST	Gain
Slot 17 (OPT-BST L),Port 6 (LINE-TX)	12/08/05 12:48:51 PST	Gain

Run APC Disable APC Refresh Help

NET CKT 151027

The APC subtab provides the following information:

- Slot ID—The ONS 15454 slot number for which APC information is shown.
- Port—The port number for which APC information is shown.

- Card—The card for which power control information is shown.
- Last Modification—Date and time APC last modified a setpoint for the parameters shown in [Table 4-2](#).
- Last Check—Date and time APC last verified the setpoints for the parameters shown in [Table 4-2](#).

Table 4-2 APC-Managed Parameters

Card	Port	Parameters
OPT-BST	LINE-3-TX	<ul style="list-style-type: none"> • Gain • Total Signal Output Power
OPT-PRE	LINE-1-TX	<ul style="list-style-type: none"> • Gain • Total Signal Output Power
AD-xB-xx.x	LINE-1-TX BAND- n^1 -TX	VOA Target Attenuation
AD-1C-xx.x AD-2C-xx.x	LINE-1-TX	VOA Target Attenuation
AD-4C-xx.x	LINE-1-TX CHAN- n^2 -TX	VOA Target Attenuation
32DMX	LINE-1-TX	VOA Target Attenuation

1. $n = 1 - 8$

2. $n = 1 - 32$

4.5 ROADM Power Equalization Monitoring

ROADM nodes allow you to monitor the 32WSS card equalization functions on the Maintenance > DWDM > Power Monitoring tab ([Figure 4-9](#)). The tab shows the input channel power (Padd), the express or pass-through (Ppt) power and the power level at output (Pout).

Figure 4-9 Power Monitoring Subtab

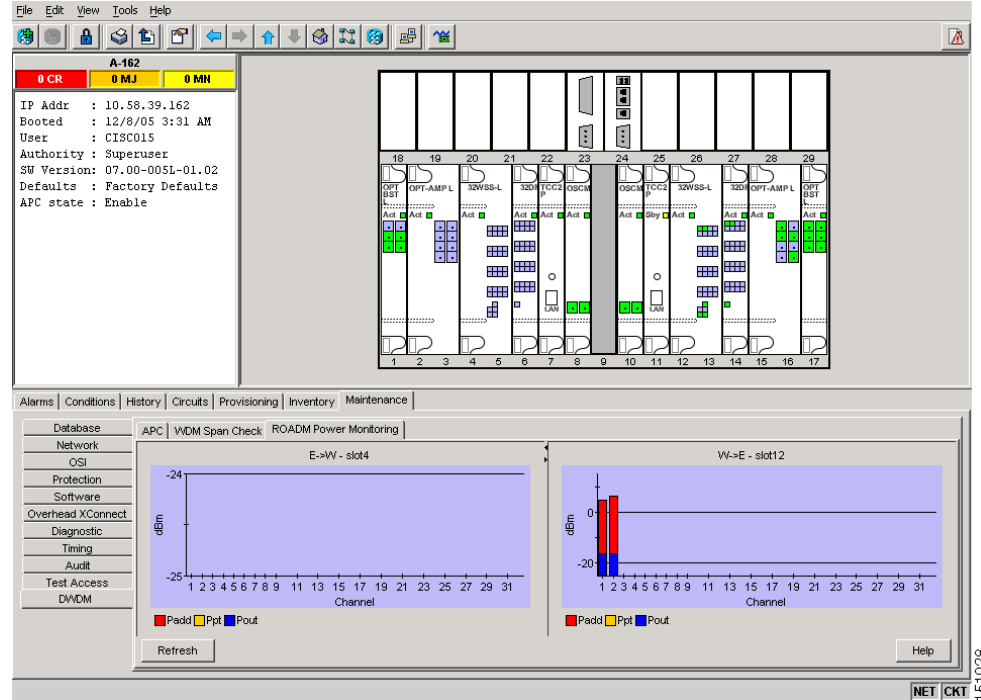

4.6 Span Loss Verification

Span loss measurements can be performed from the Maintenance > DWDM > WDM Span Check tab (Figure 4-10). The CTC span check compares the far-end OSC power with the near-end OSC power. A Span Loss Out of Range condition is raised when the measured span loss is higher than the maximum expected span loss. It is also raised when the measured span loss is lower than the minimum expected span loss and the difference between the minimum and maximum span loss values is greater than 1 dB. The minimum and maximum expected span loss values are calculated by Cisco MetroPlanner for the network and imported into CTC. However, you can manually change the minimum and expected span loss values.

CTC span loss measurements provide a quick span loss check and are useful whenever changes to the network occur, for example after you install equipment or repair a broken fiber. CTC span loss measurement resolutions are:

- +/- 1.5 dB for measured span losses between 0 and 25 dB
- +/- 2.5 dB for measured span losses between 25 and 38 dB

For ONS 15454 span loss measurements with higher resolutions, an optical time domain reflectometer (OTDR) must be used.

Figure 4-10 Span Loss Verification

The screenshot shows the Cisco CTC interface for card A-162. The top left pane displays system information:

```

A-162
0 CR 0 MJ 0 MH
IP Addr : 10.58.39.162
Booted : 12/8/05 3:31 AM
User : CISCO15
Authority : Superuser
SW Version: 07.00-005L-01.02
Defaults : Factory Defaults
APC state : Enable

```

The main area shows a rack diagram with 17 slots. Slots 18-29 contain various optical cards. Below the diagram is a table showing span loss verification results:

Database	APC	VDM Span Check	ROADM Power Monitoring		
Network					
OSI					
Protection	West	5.1	14.9	9.0	1.5
Software	East	5.2	14.8	12.4	1.5
Overhead XConnect					
Diagnostic					
Timing					
Audit					
Test Access					
DVDM					

Buttons at the bottom include: Retrieve Span Loss values, Reset, Apply, and Help.

4.7 Network Optical Safety—Automatic Laser Shutdown

If a fiber break occurs on the network, automatic laser shutdown (ALS) automatically shuts down the OSCM and OSC-CSM OSC laser output power and the optical amplifiers contained in the OPT-BST, OPT-BST-E, OPT-BST-L, and OPT-AMP-L cards. The Maintenance > ALS tabs in CTC card view provide the following ALS management options for OSCM, OSC-CSM, OPT-BST, OPT-BST-E, OPT-BST-L, and OPT-AMP-L cards:

- **Disable**—ALS is off. The OSC laser transmitter and optical amplifiers are not automatically shut down when a traffic outage loss of signal (LOS) occurs.
- **Auto Restart**—ALS is on. The OSC laser transmitter and optical amplifiers automatically shut down when traffic outages (LOS) occur. It automatically restarts when the conditions that caused the outage are resolved. Auto Restart is the default ALS provisioning for OSCM, OSC-CSM, OPT-BST, OPT-BST-E, OPT-BST-L, and OPT-AMP-L cards.
- **Manual Restart**—ALS is on. The OSC laser transmitter and optical amplifiers automatically shut down when traffic outages (LOS) occur. However, the laser must be manually restarted when conditions that caused the outage are resolved.
- **Manual Restart for Test**—Manually restarts the OSC laser transmitter and optical amplifiers for testing.

4.7.1 Automatic Laser Shutdown on TXP and MXP Cards

When ALS is enabled on OPT-BST, OPT-BST-E, OPT-BST-L, OPT-AMP-L, OSCM, and OSC-CSM cards, a network safety mechanism will occur in the event of a system failure. ALS provisioning is also provided on the transponder (TXP) and muxponder (MXP) cards. However, if a network uses ALS-enabled OPT-BST, OPT-BST-E, OPT-BST-L, OPT-AMP-L, OSCM, and OSC-CSM cards, ALS does not need to be enabled on the TXP cards or MXP cards. ALS is disabled on TXP and MXP cards by default and the network optical safety is not impacted.

If TXP and MXP cards are connected directly to each other without passing through a DWDM layer, ALS should be enabled on them. The ALS protocol goes into effect when a fiber is cut, enabling some degree of network point-to-point bidirectional traffic management between the cards.

If ALS is disabled on the OPT-BST, OPT-BST-E, OPT-BST-L, OPT-AMP-L, OSCM, and OSC-CSM cards (the DWDM network), ALS can be enabled on the TXP and MXP cards to provide laser management in the event of a fiber break in the network between the cards.

4.7.2 Automatic Power Reduction

Automatic power reduction (APR) is controlled by the software and is not user configurable. During amplifier restart after a system failure, the amplifier (OPT-BST, for example) operates in pulse mode and an automatic power reduction level is activated so that the Hazard Level 1 power limit is not exceeded. This is done to ensure personnel safety.

When a system failure occurs (cut fiber or equipment failure, for example) and ALS Auto Restart is enabled, a sequence of events is placed in motion to shut down the amplifier laser power, then automatically restart the amplifier after the system problem is corrected. As soon as a loss of optical payload and OSC is detected at the far end, the far-end amplifier shuts down. The near-end amplifier then shuts down because in similar fashion, it detects a loss of payload and OSC due to the far-end amplifier shutdown. At this point, the near end attempts to establish communication to the far end using the OSC laser transmitter. To do this, the OSC emits a two-second pulse at very low power (maximum of 0 dB) and waits for a similar two-second pulse in response from the far-end OSC laser transmitter. If no response is received within 100 seconds, the near end tries again. This process continues until the near end receives a two-second response pulse from the far end. This is an indication that the system failure has been corrected and that there is full continuity in the fiber between the two ends.

After the OSC communication has been established, the near-end amplifier is configured by the software to operate in pulse mode at a reduced power level. It emits a nine-second laser pulse with an automatic power reduction to +8 dB. This level assures that Hazard Level 1 is not exceeded, for personnel safety, even though the establishment of successful OCS communication has assured that any broken fiber has been fixed. If the far-end amplifier responds with a nine-second pulse within 100 seconds, both amplifiers are changed from pulse mode at reduced power to normal operating power mode.

For a direct connection between TXP or MXP cards, when ALS Auto Restart is enabled and the connections do not pass through a DWDM layer, a similar process takes place. However, because the connections do not go through any amplifier or OSC cards, the TXP or MXP cards attempt to establish communication directly between themselves after a system failure. This is done using a two-second restart pulse, in a manner similar to that previously described between OSCs at the DWDM layer. The power emitted during the pulse is below Hazard Level 1.

**Note**

In the event that ALS is disabled, a larger amount of invisible laser radiation might be emitted from the end of the unterminated fiber cable or connector. Do not view the end of the fiber directly with optical instruments. Viewing the laser output with certain optical instruments (for example, eye loupes, magnifiers, and microscopes) within a distance of 100 mm may pose an eye hazard.

**Note**

If you must disable ALS, ensure that all fibers are installed in a restricted location. Enable ALS immediately after finishing the maintenance or installation process.

**Note**

For the line amplifier to start up automatically, disable the ALS on the terminal node that is unidirectional.

4.7.3 Fiber Cut Scenarios

In the following paragraphs, four ALS scenarios are given:

- Nodes using OPT-BST/OPT-BST-E cards (amplified nodes)
- Nodes using OSC-CSM cards (passive nodes)
- Nodes using OPT-BST-L cards (amplified nodes)
- Nodes using OPT-AMP-L cards (amplified nodes)

4.7.3.1 Scenario 1: Fiber Cut in Nodes Using OPT-BST/OPT-BST-E Cards

[Figure 4-11](#) shows nodes using OPT-BST/OPT-BST-E cards with a fiber cut between them.

Figure 4-11 Nodes Using OPT-BST/OPT-BST-E Cards

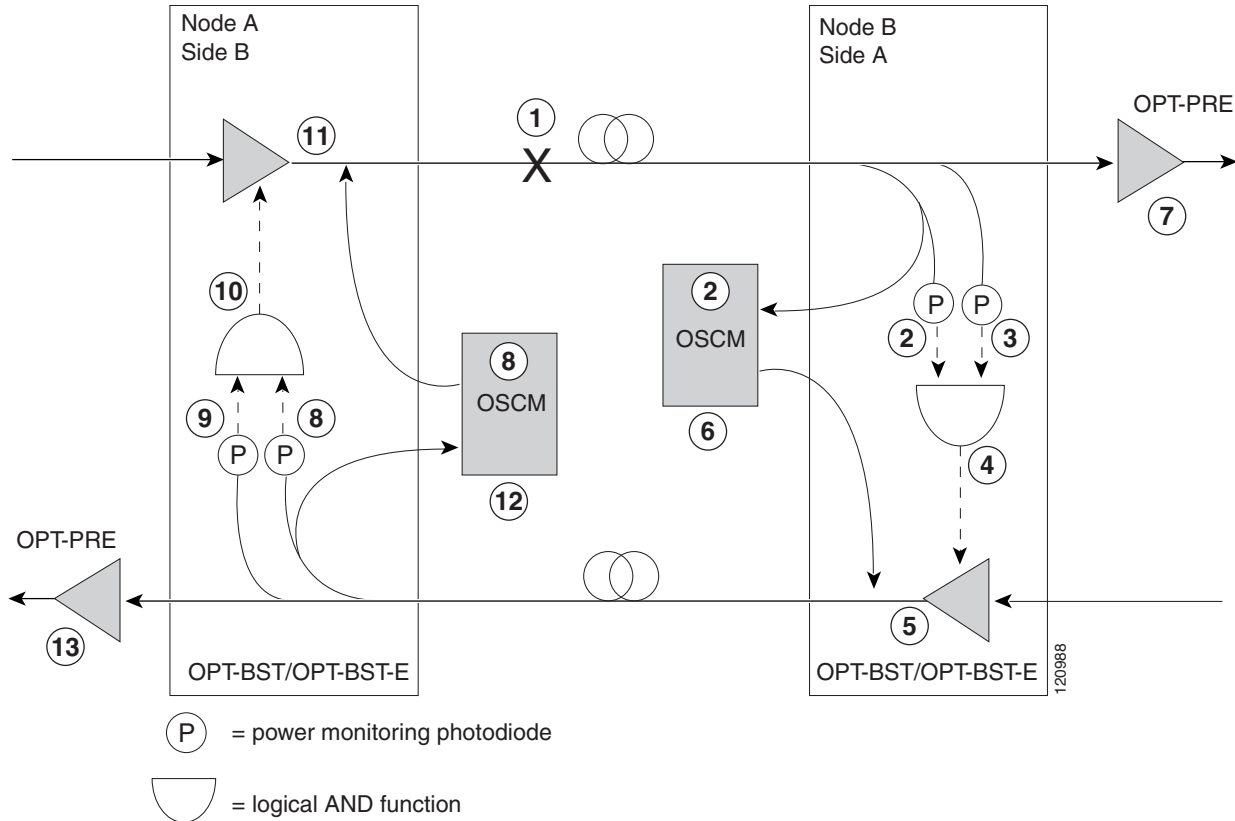

Two photodiodes at Node B monitor the received signal strength for the optical payload and OSC signals. When the fiber is cut, an LOS is detected at both of the photodiodes. The AND function then indicates an overall LOS condition, which causes the OPT-BST/OPT-BST-E transmitter, OPT-PRE transmitter, and OSCM lasers to shut down. This in turn leads to a LOS for both the optical payload and OSC at Node A, which causes Node A to turn off the OSCM, OPT-PRE transmitter, and OPT-BST/OPT-BST-E transmitter lasers. The sequence of events after a fiber cut is as follows (refer to the numbered circles in Figure 4-11):

1. Fiber is cut.
2. The Node B power monitoring photodiode detects a Loss of Incoming Payload (LOS-P) on the OPT-BST/OPT-BST-E card. Refer to the *Cisco ONS 15454 DWDM Troubleshooting Guide*.
3. On the OPT-BST/OPT-BST-E card, the simultaneous LOS-O and LOS-P detection triggers a command to shut down the amplifier. CTC reports an LOS alarm (loss of continuity), while LOS-O and LOS-P are demoted. Refer to the *Cisco ONS 15454 DWDM Troubleshooting Guide*.
4. The OPT-BST/OPT-BST-E card amplifier is shut down within three seconds.
5. The OSCM laser is shut down.
6. The OPT-PRE card automatically shuts down due to a loss of incoming optical power.
7. The Node A power monitoring photodiode detects a LOS-O on the OPT-BST/OPT-BST-E card and the OSCM card detects a LOS (OC3) at the SONET layer. Refer to the *Cisco ONS 15454 DWDM Troubleshooting Guide*.
8. The Node A power monitoring photodiode detects a LOS-P on the OPT-BST/OPT-BST-E card. Refer to the *Cisco ONS 15454 DWDM Troubleshooting Guide*.

9. On the OPT-BST/OPT-BST-E, the simultaneous LOS-O and LOS-P detection triggers a command to shut down the amplifier. CTC reports an LOS alarm (loss of continuity), while LOS-O and LOS-P are demoted. Refer to the *Cisco ONS 15454 DWDM Troubleshooting Guide*.
10. The OPT-BST/OPT-BST-E card amplifier is shut down within three seconds.
11. The OSCM laser is shut down.
12. The Node A OPT-PRE card automatically shuts down due to a loss of incoming optical power.

When the fiber is repaired, either an automatic or manual restart at the Node A OPT-BST/OPT-BST-E transmitter or at the Node B OPT-BST/OPT-BST-E transmitter is required. A system that has been shut down is reactivated through the use of a restart pulse. The pulse is used to signal that the optical path has been restored and transmission can begin. For example, when the far end, Node B, receives a pulse, it signals to the Node B OPT-BST/OPT-BST-E transmitter to begin transmitting an optical signal. The OPT-BST/OPT-BST-E receiver at Node A receives that signal and signals the Node A OPT-BST/OPT-BST-E transmitter to resume transmitting.

**Note**

During a laser restart pulse, APR (see the “[4.7.2 Automatic Power Reduction](#)” section on page 4-15) ensures that the laser power does not exceed Class 1 limits.

4.7.3.2 Scenario 2: Fiber Cut in Nodes Using OSC-CSM Cards

[Figure 4-12](#) shows nodes using OSC-CSM cards with a fiber cut between them.

Figure 4-12 Nodes Using OSC-CSM Cards

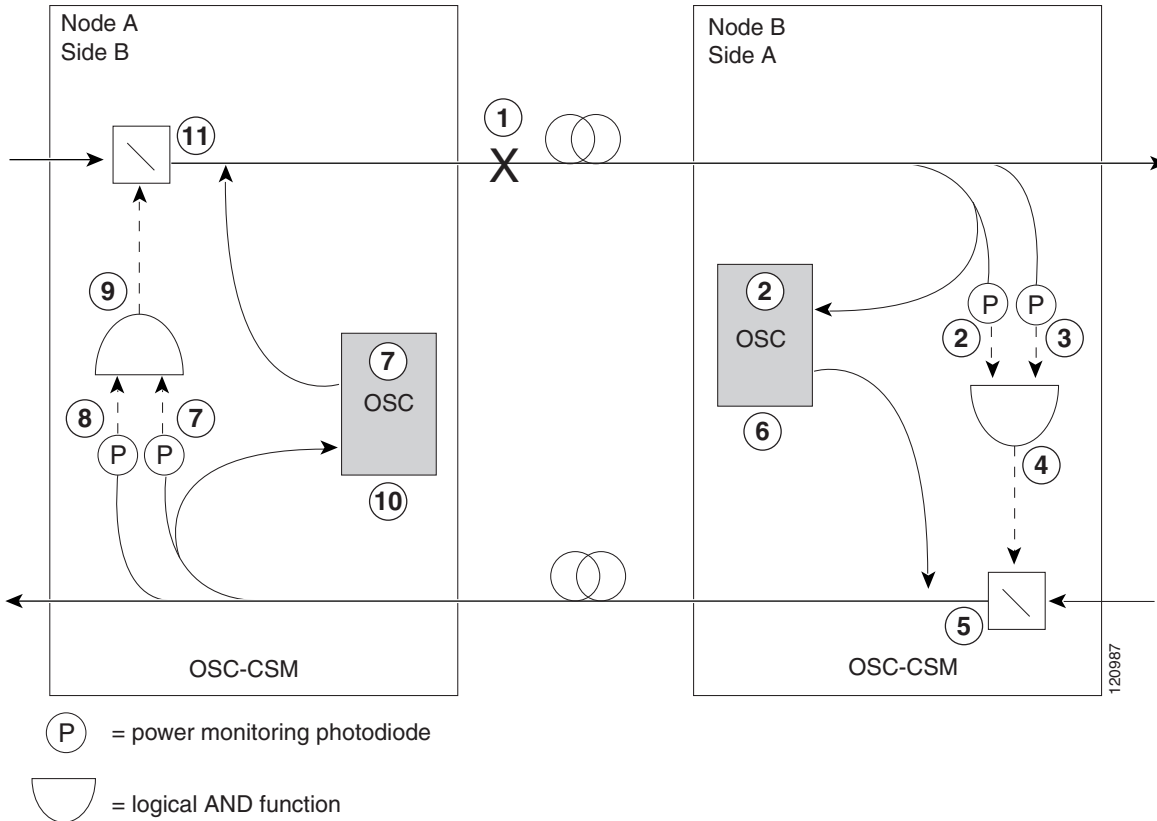

Two photodiodes at the Node B OSC-CSM card monitor the received signal strength for the received optical payload and OSC signals. When the fiber is cut, LOS is detected at both of the photodiodes. The AND function then indicates an overall LOS condition, which causes the Node B OSC laser to shut down and the optical switch to block traffic. This in turn leads to LOS for both the optical payload and OSC signals at Node A, which causes Node A to turn off the OSC laser and the optical switch to block outgoing traffic. The sequence of events after a fiber cut is as follows (refer to the numbered circles in Figure 4-12):

1. Fiber is cut.
2. The Node B power monitoring photodiode detects a LOS-P on the OSC-CSM card. Refer to the *Cisco ONS 15454 DWDM Troubleshooting Guide*.
3. On the OSC-CSM, the simultaneous LOS-O and LOS-P detection triggers a change in the position of the optical switch. CTC reports a LOS alarm (loss of continuity), while LOS-O and LOS-P are demoted. Refer to the *Cisco ONS 15454 DWDM Troubleshooting Guide*.
4. The optical switch blocks outgoing traffic.
5. The OSC laser is shut down.
6. The Node A power monitoring photodiode detects a LOS-O on the OSC-CSM card. Refer to the *Cisco ONS 15454 DWDM Troubleshooting Guide*.
7. The Node A power monitoring photodiode detects a LOS-P on the OSC-CSM card. Refer to the *Cisco ONS 15454 DWDM Troubleshooting Guide*.

8. On the OSC-CSM, the simultaneous LOS-O and LOS-P detection triggers a change in the position of the optical switch. CTC reports a LOS alarm (loss of continuity), while LOS-O and LOS-P are demoted. Refer to the *Cisco ONS 15454 DWDM Troubleshooting Guide*.
9. The OSC laser is shut down.
10. The optical switch blocks outgoing traffic.

When the fiber is repaired, either an automatic or manual restart at the Node A OSC-CSM OSC or at the Node B OSC-CSM OSC is required. A system that has been shut down is reactivated through the use of a restart pulse. The pulse is used to signal that the optical path has been restored and transmission can begin. For example, when the far-end Node B receives a pulse, it signals to the Node B OSC to begin transmitting its optical signal and for the optical switch to pass incoming traffic. The OSC-CSM at Node A then receives the signal and tells the Node A OSC to resume transmitting and for the optical switch to pass incoming traffic.

4.7.3.3 Scenario 3: Fiber Cut in Nodes Using OPT-BST-L Cards

Figure 4-13 shows nodes using OPT-BST-L cards with a fiber cut between them.

Figure 4-13 Nodes Using OPT-BST-L Cards

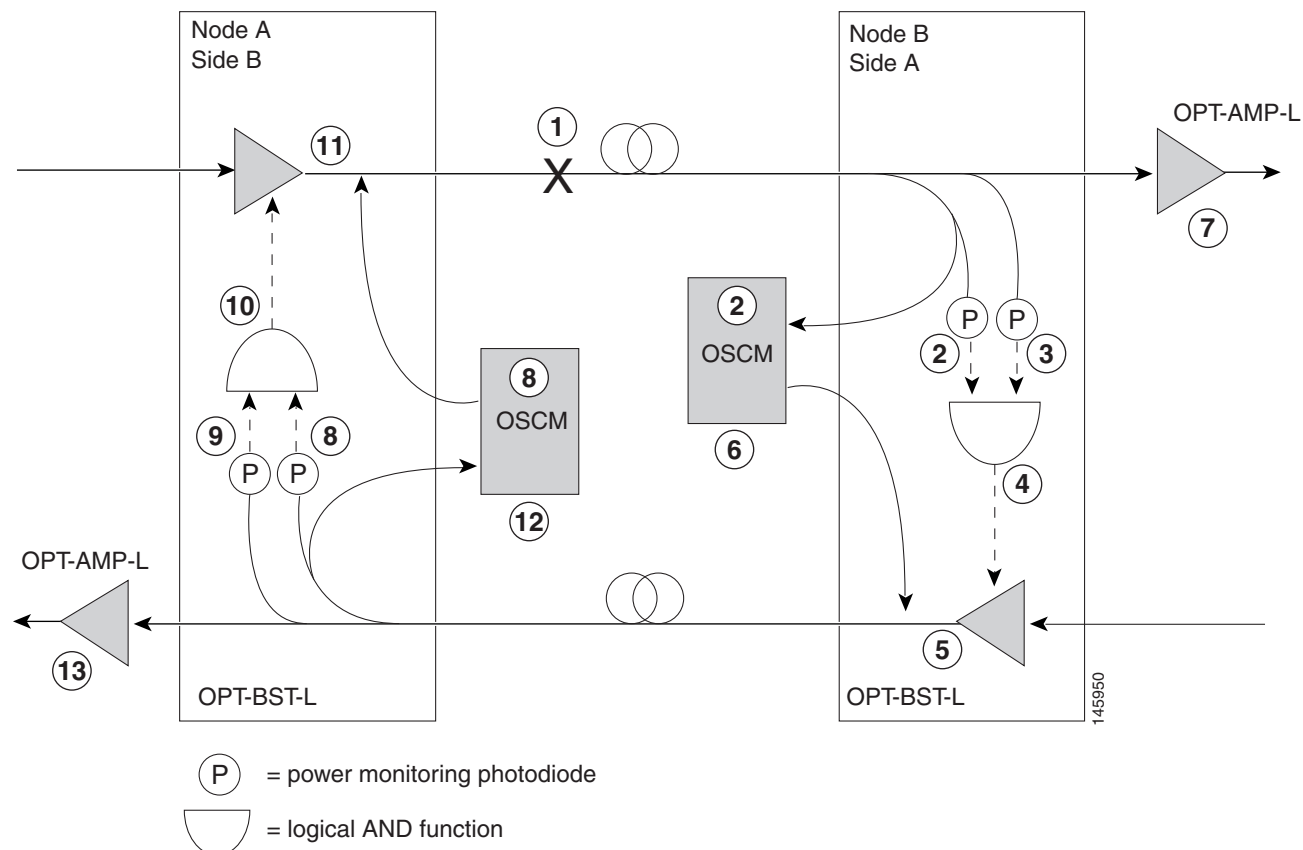

Two photodiodes at Node B monitor the received signal strength for the optical payload and OSC signals. When the fiber is cut, an LOS is detected at both of the photodiodes. The AND function then indicates an overall LOS condition, which causes the OPT-BST-L transmitter and OSCM lasers to shut down. This

in turn leads to a LOS for both the optical payload and OSC at Node A, which causes Node A to turn off the OSCM OSC transmitter and OPT-BST-L amplifier lasers. The sequence of events after a fiber cut is as follows (refer to the numbered circles in [Figure 4-13](#)):

1. Fiber is cut.
2. The Node B power monitoring photodiode detects a LOS-P on the OPT-BST-L card. Refer to the *Cisco ONS 15454 DWDM Troubleshooting Guide*.
3. On the OPT-BST-L card, the simultaneous LOS-O and LOS-P detection triggers a command to shut down the amplifier. CTC reports an LOS alarm (loss of continuity), while LOS-O and LOS-P are demoted. Refer to the *Cisco ONS 15454 DWDM Troubleshooting Guide*.
4. The OPT-BST-L card amplifier is shut down within three seconds.
5. The OSCM laser is shut down.
6. The OPT-AMP-L card automatically shuts down due to a loss of incoming optical power.
7. The Node A power monitoring photodiode detects a LOS-O on the OPT-BST-L card and the OSCM card detects a LOS (OC3) at the SONET layer. Refer to the *Cisco ONS 15454 DWDM Troubleshooting Guide*.
8. The Node A power monitoring photodiode detects a LOS-P on the OPT-BST-L card. Refer to the *Cisco ONS 15454 DWDM Troubleshooting Guide*.
9. On the OPT-BST-L, the simultaneous LOS-O and LOS-P detection triggers a command to shut down the amplifier. CTC reports an LOS alarm (loss of continuity), while LOS-O and LOS-P are demoted. Refer to the *Cisco ONS 15454 DWDM Troubleshooting Guide*.
10. The OPT-BST-L card amplifier is shut down within three seconds.
11. The OSCM laser is shut down.
12. The Node A OPT-AMP-L card automatically shuts down due to a loss of incoming optical power.

When the fiber is repaired, either an automatic or manual restart at the Node A OPT-BST-L transmitter or at the Node B OPT-BST-L transmitter is required. A system that has been shut down is reactivated through the use of a restart pulse. The pulse is used to signal that the optical path has been restored and transmission can begin. For example, when the far end, Node B, receives a pulse, it signals to the Node B OPT-BST-L transmitter to begin transmitting an optical signal. The OPT-BST-L receiver at Node A receives that signal and signals the Node A OPT-BST-L transmitter to resume transmitting.

**Note**

During a laser restart pulse, APR (see the “[4.7.2 Automatic Power Reduction](#)” section on page 4-15) ensures that the laser power does not exceed Class 1 limits.

4.7.3.4 Scenario 4: Fiber Cut in Nodes Using OPT-AMP-L (OPT-BST mode) Cards

[Figure 4-14](#) shows nodes using OPT-AMP-L (in OPT-BST mode) cards with a fiber cut between them.

Figure 4-14 Nodes Using OPT-AMP-L Cards

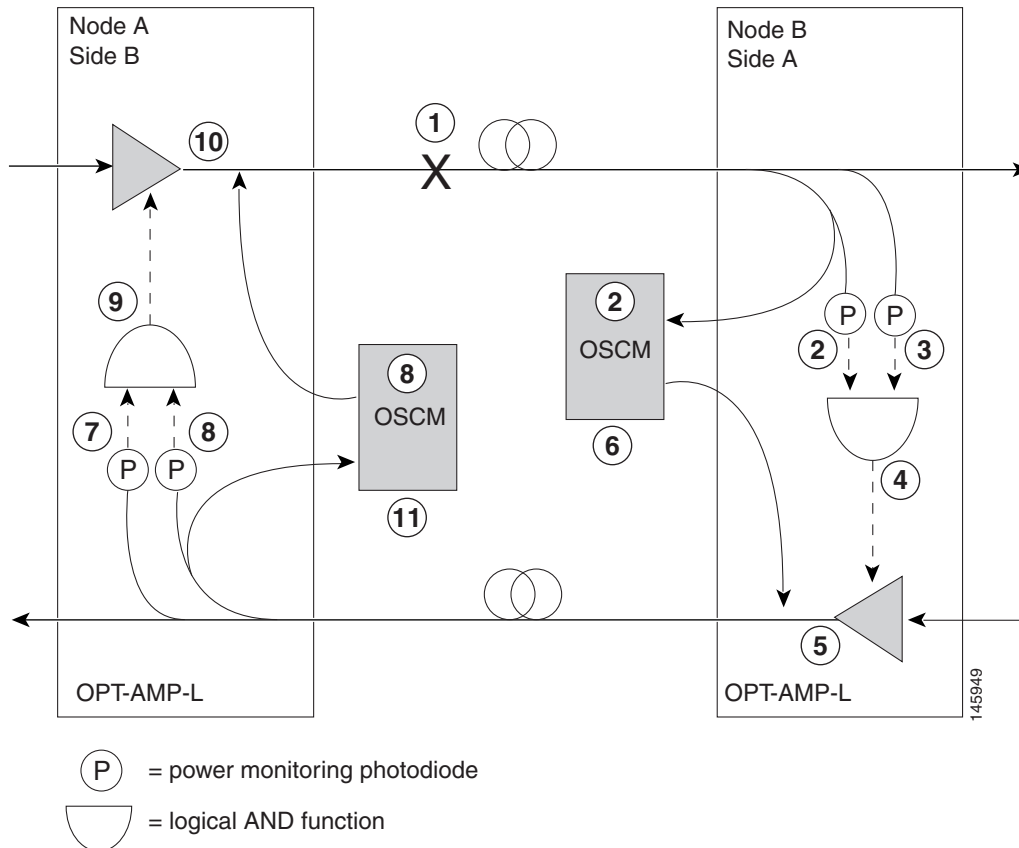

Two photodiodes at Node B monitor the received signal strength for the optical payload and OSC signals. When the fiber is cut, an LOS is detected at both of the photodiodes. The AND function then indicates an overall LOS condition, which causes the OPT-AMP-L amplifier transmitter and OSCM OSC lasers to shut down. This in turn leads to a LOS for both the optical payload and OSC at Node A, which causes Node A to turn off the OSCM OSC and OPT-AMP-L amplifier lasers. The sequence of events after a fiber cut is as follows (refer to the numbered circles in Figure 4-14):

1. Fiber is cut.
2. The Node B power monitoring photodiode detects an LOS-P on the OPT-AMP-L card. Refer to the *Cisco ONS 15454 DWDM Troubleshooting Guide*.
3. On the OPT-AMP-L card, the simultaneous LOS-O and LOS-P detection triggers a command to shut down the amplifier. CTC reports an LOS alarm (loss of continuity), while LOS-O and LOS-P are demoted. Refer to the *Cisco ONS 15454 DWDM Troubleshooting Guide*.
4. The OPT-AMP-L card amplifier is shut down within three seconds.
5. The OSCM laser is shut down.
6. The Node A power monitoring photodiode detects a LOS-O on the OPT-AMP-L card and the OSCM card detects a LOS (OC3) at the SONET layer. Refer to the *Cisco ONS 15454 DWDM Troubleshooting Guide*.
7. The Node A power monitoring photodiode detects a LOS-P on the OPT-AMP-L card. Refer to the *Cisco ONS 15454 DWDM Troubleshooting Guide*.

8. On the OPT-AMP-L, the simultaneous LOS-O and LOS-P detection triggers a command to shut down the amplifier. CTC reports an LOS alarm (loss of continuity), while LOS-O and LOS-P are demoted. Refer to the *Cisco ONS 15454 DWDM Troubleshooting Guide*.
9. The OPT-AMP-L card amplifier is shut down within three seconds.
10. The OSCM laser is shut down.

When the fiber is repaired, either an automatic or manual restart at the Node A OPT-AMP-L transmitter or at the Node B OPT-AMP-L transmitter is required. A system that has been shut down is reactivated through the use of a restart pulse. The pulse is used to signal that the optical path has been restored and transmission can begin. For example, when the far end, Node B, receives a pulse, it signals to the Node B OPT-AMP-L transmitter to begin transmitting an optical signal. The OPT-AMP-L receiver at Node A receives that signal and signals the Node A OPT-AMP-L transmitter to resume transmitting.

**Note**

During a laser restart pulse, APR (see the “[4.7.2 Automatic Power Reduction](#)” section on page 4-15) ensures that the laser power does not exceed Class 1 limits.

4.8 Network-Level Gain—Tilt Management of Optical Amplifiers

The ability to control and adjust per-channel optical power equalization is a principal feature of ONS 15454 DWDM Metro Core network applications. A critical parameter to assure optical spectrum equalization throughout the DWDM system is the gain flatness of Erbium-doped fiber amplifiers (EDFAs).

Two items, gain tilt and gain ripple, are factors in the power equalization of optical amplifier cards such as the OPT-BST and OPT-PRE. [Figure 4-15](#) shows a graph of the amplifier output power spectrum and how it is affected by gain tilt and gain ripple.

Figure 4-15 Effect of Gain Ripple and Gain Tilt on Amplifier Output Power

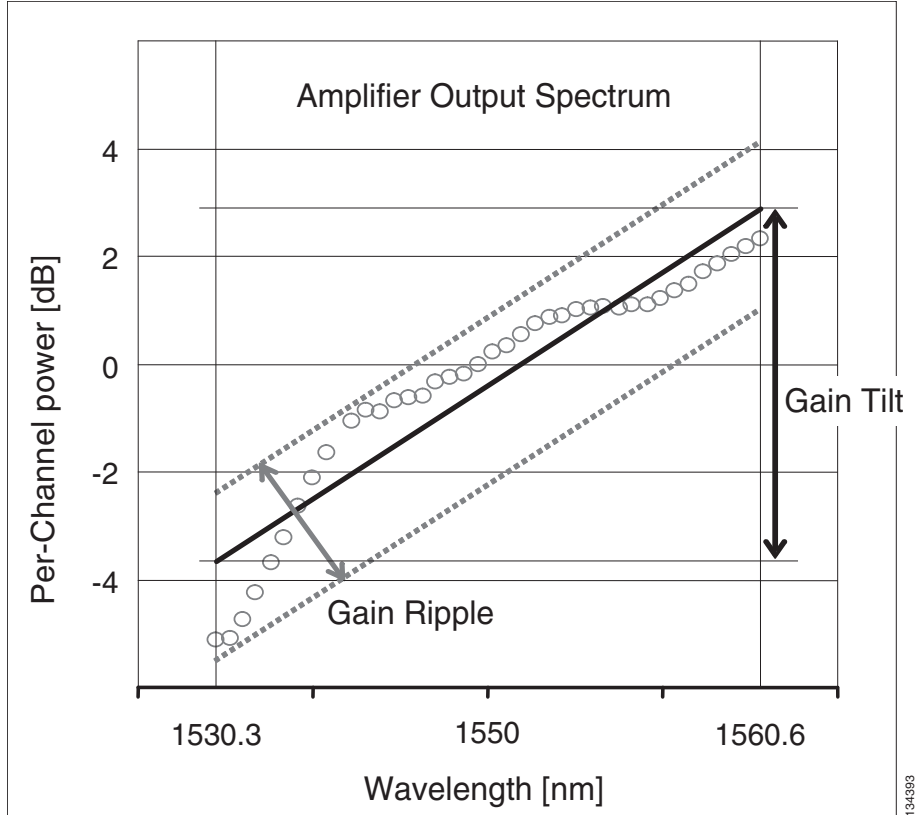

Gain ripple and gain tilt are defined as follows:

- Gain ripple is random and depends on the spectral shape of the amplifier optical components.
- Gain tilt is systematic and depends on the gain setpoint (G_{stp}) of the optical amplifier, which is a mathematical function $F(G_{stp})$ that relates to the internal amplifier design.

Gain tilt is the only contribution to the power spectrum disqualification that can be compensated at the card level. A VOA internal to the amplifier can be used to compensate for gain tilt.

An optical spectrum analyzer (OSA) is used to acquire the output power spectrum of an amplifier. The OSA shows the peak-to-peak difference between the maximum and minimum power levels, and takes into account the contributions of both gain tilt and gain ripple.



Note

Peak-to-peak power acquisition using an OSA cannot be used to “measure” the gain tilt, because gain ripple itself is a component of the actual measurement.

4.8.1 Gain Tilt Control at the Card Level

The OPT-BST and OPT-PRE amplifier cards have a flat output (gain tilt = 0 dB) for only a specific gain value (G_{design}), based on the internal optical design (see [Figure 4-16](#)).

Figure 4-16 Flat Gain (Gain Tilt = 0 dB)

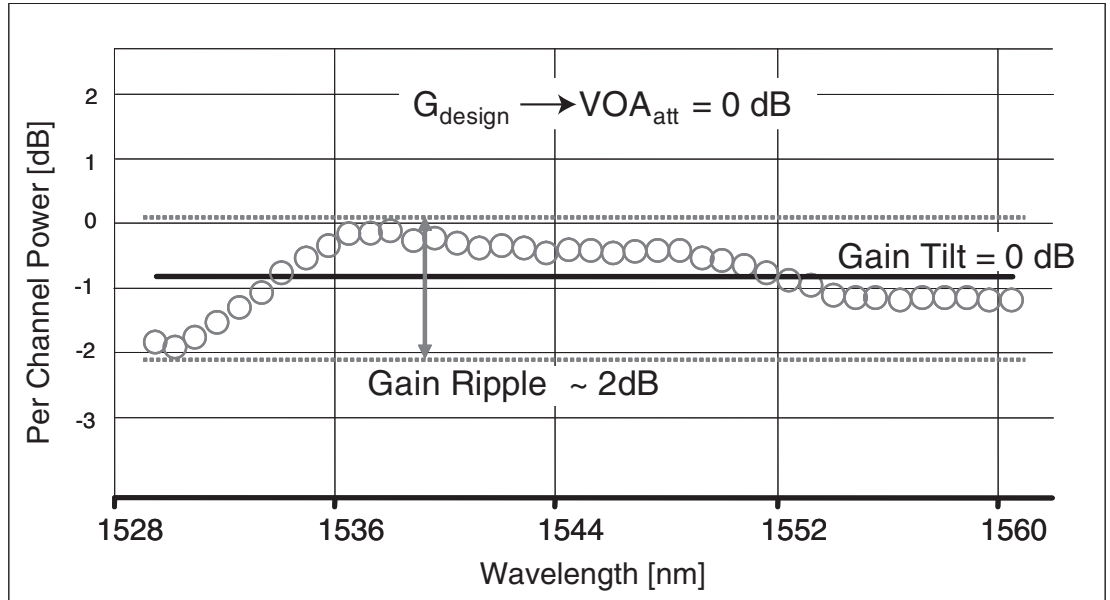

If the working gain setpoint of the amplifier is different from G_{design} , the output spectrum begins to suffer a gain tilt variation.

In order to compensate for the absolute value of the increase of the spectrum tilt, the OPT-BST and OPT-PRE cards automatically adjust the attenuation of the VOA to maintain a flat power profile at the output, as shown in Figure 4-17.

Figure 4-17 Effect of VOA Attenuation on Gain Tilt

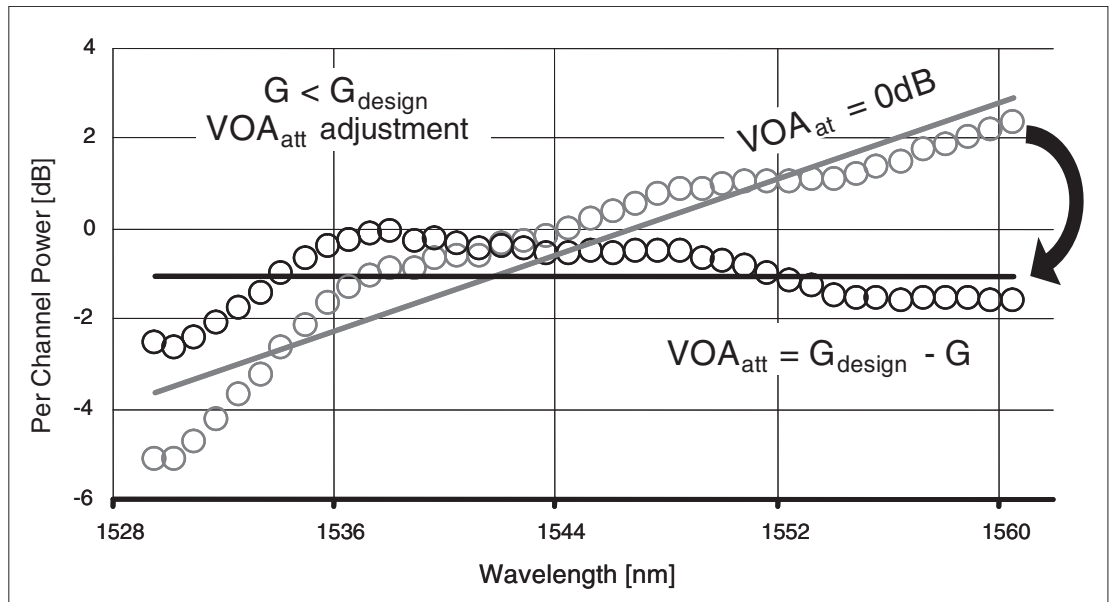

The VOA attenuator automatic regulation guarantees (within limits) a zero tilt condition in the EDFA for a wide range of possible gain setpoint values.

Table 4-3 shows the flat output gain range limits for the OPT-BST and OPT-PRE cards, as well as the maximum (worst case) values of gain tilt and gain ripple expected in the specific gain range.

Table 4-3 Flat Output Gain Range Limits

Amplifier Card Type	Flat Output Gain Range	Gain Tilt (Maximum)	Gain Ripple (Maximum)
OPT-BST	$G < 20$ dB	0.5 dB	1.5 dB
OPT-PRE	$G < 21$ dB	0.5 dB	1.5 dB

If the operating gain value is outside of the range shown in Table 4-3, the EDFA introduces a tilt contribution for which the card itself cannot directly compensate. This condition is managed in different ways, depending on the amplifier card type:

- OPT-BST—The OPT-BST amplifier is, by card design, not allowed to work outside the zero tilt range. The Cisco MetroPlanner tool validates network designs using the OPT-BST amplifier card only when the gain is less than or equal to 20 dB.
- OPT-PRE—The Cisco MetroPlanner tool allows network designs even if the operating gain value is equal to or greater than 21 dB. In this case, a system-level tilt compensation strategy is adopted by the DWDM system. A more detailed explanation is given in Section 4.8.2 [System Level Gain Tilt Control](#).

4.8.2 System Level Gain Tilt Control

System level gain tilt control for OPT-PRE cards is achievable with two main scenarios:

- Without an ROADM node
- With an ROADM node

4.8.2.1 System Gain Tilt Compensation Without ROADM Nodes

When an OPT-PRE card along a specific line direction (west-to-east or east-to-west) is working outside the flat output gain range ($G > 21$ dB), the unregulated tilt is compensated for in spans not connected to ROADM nodes by configuring an equal but opposite tilt on one or more of the amplifiers in the downstream direction. The number of downstream amplifiers involved depends on the amount of tilt compensation needed and the gain setpoint of the amplifiers that are involved. See Figure 4-18.

Figure 4-18 System Tilt Compensation Without an ROADM Node

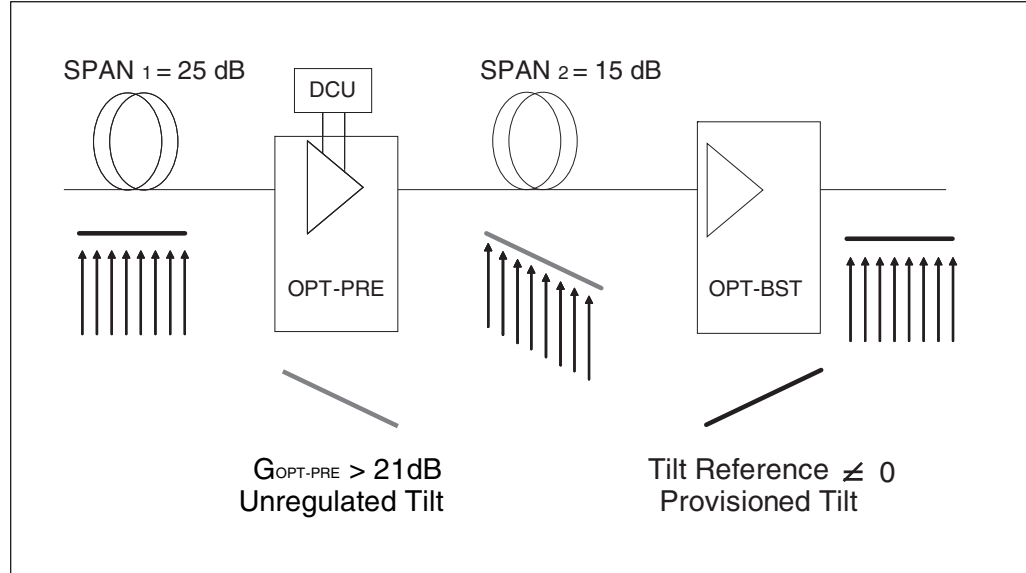

The proper Tilt Reference value is calculated by Cisco MetroPlanner and inserted in the Installation Parameter List imported during the node turn-up process (see the “Turn Up a Node” chapter in the *Cisco ONS 15454 DWDM Procedure Guide*). For both OPT-PRE and OPT-BST cards, the provisionable Gain Tilt Reference range is between -3 dB and $+3$ dB.

During the Automatic Node Setup (ANS) procedure, the Tilt value for the OPT-BST or OPT-PRE card is provisioned by the TCC2/TCC2P card (see [Figure 4-19](#)). The provisioned Tilt Reference Value is reported in the CTC OPT-PRE or OPT-BST card view (in the Provisioning > Opt. Ampli. Line > Parameters > Tilt Reference tab).

Figure 4-19 Cisco MetroPlanner Installation Parameters

Side	Position	Unit	Port#	Port ID	Port Label	Parameter	Value	Measurement Unit	Manual Set
N/A						NetworkType	Metro-Core	string	No
SideEast	Rack #1 Main Shelf 16	15454E-OPT-PRE	2	LINE-16-1-TX	COM-TX	dwdm:Rc:SideEast:Amplifier:ChPower	2.0	dBm	No
SideEast	Rack #1 Main Shelf 16	15454E-OPT-PRE	2	LINE-16-1-TX	COM-TX	dwdm:Rc:SideEast:Amplifier:Tilt	-3.0	dB	No
SideEast	Rack #1 Main Shelf 16	15454E-OPT-PRE	2	LINE-16-1-TX	COM-TX	dwdm:Rc:SideEast:Amplifier:WorkingMode	Control Gain	string	No
SideEast						dwdm:Rc:SideEast:MaxExpectedSpanLoss	25.0	dB	No
SideEast						dwdm:Rc:SideEast:MinExpectedSpanLoss	25.0	dB	No
SideEast						dwdm:Rc:SideEast:Power:Add-and-DropInputPower	2.0	dBm	No
SideEast	Rack #1 Main Shelf 16	15454E-OPT-PRE	2	LINE-16-1-TX	COM-TX	dwdm:Rc:SideEast:Threshold:AmplifierInPowerFail	-30.6	dBm	No
SideEast						dwdm:Rc:SideEast:Threshold:ChannelLOS	-29.6	dBm	No
SideEast						dwdm:Rc:SideEast:Threshold:OSC-LOS	-36.3	dBm	No
SideEast	Rack #1 Main Shelf 17	15454E-OPT-BST	6	LINE-17-3-TX	LINE-TX	dwdm:Tx:SideEast:Amplifier:ChPower	2.0	dBm	No
SideEast	Rack #1 Main Shelf 17	15454E-OPT-BST	6	LINE-17-3-TX	LINE-TX	dwdm:Tx:SideEast:Amplifier:Tilt	3.0	dB	No
SideEast	Rack #1 Main Shelf 17	15454E-OPT-BST	6	LINE-17-3-TX	LINE-TX	dwdm:Tx:SideEast:Amplifier:WorkingMode	Control Gain	string	No
SideEast						dwdm:Tx:SideEast:Power:Add-and-DropOutputPo...	-8.0	dBm	No
SideEast						dwdm:Tx:SideEast:Threshold:FiberStageInput	-13.0	dBm	No
SideWest	Rack #1 Main Shelf 02	15454E-OPT-PRE	2	LINE-2-1-TX	COM-TX	dwdm:Rc:SideWest:Amplifier:ChPower	2.0	dBm	No
SideWest	Rack #1 Main Shelf 02	15454E-OPT-PRE	2	LINE-2-1-TX	COM-TX	dwdm:Rc:SideWest:Amplifier:Tilt	-3.0	dB	No
SideWest	Rack #1 Main Shelf 02	15454E-OPT-PRE	2	LINE-2-1-TX	COM-TX	dwdm:Rc:SideWest:Amplifier:WorkingMode	Control Gain	string	No
SideWest						dwdm:Rc:SideWest:MaxExpectedSpanLoss	25.0	dB	No
SideWest						dwdm:Rc:SideWest:MinExpectedSpanLoss	25.0	dB	No
SideWest						dwdm:Rc:SideWest:Power:Add-and-DropInputPow...	2.0	dBm	No
SideWest	Rack #1 Main Shelf 02	15454E-OPT-PRE	2	LINE-2-1-TX	COM-TX	dwdm:Rc:SideWest:Threshold:AmplifierInPowerFail	-29.8	dBm	No
SideWest						dwdm:Rc:SideWest:Threshold:ChannelLOS	-28.8	dBm	No
SideWest						dwdm:Rc:SideWest:Threshold:OSC-LOS	-36.3	dBm	No
SideWest	Rack #1 Main Shelf 01	15454E-OPT-BST	6	LINE-1-3-TX	LINE-TX	dwdm:Tx:SideWest:Amplifier:ChPower	2.0	dBm	No
SideWest	Rack #1 Main Shelf 01	15454E-OPT-BST	6	LINE-1-3-TX	LINE-TX	dwdm:Tx:SideWest:Amplifier:Tilt	3.0	dB	No
SideWest	Rack #1 Main Shelf 01	15454E-OPT-BST	6	LINE-1-3-TX	LINE-TX	dwdm:Tx:SideWest:Amplifier:WorkingMode	Control Gain	string	No
SideWest						dwdm:Tx:SideWest:Power:Add-and-DropOutputPo...	-8.0	dBm	No
SideWest						dwdm:Tx:SideWest:Threshold:FiberStageInput	-13.0	dBm	No

4.8.2.2 System Gain Tilt Compensation With ROADM Nodes

When an ROADM node is present in the network, as shown in Figure 4-20, a per-channel dynamic gain equalization can be performed. Both gain tilt and gain ripple are completely compensated using the following techniques:

- Implementing the per-channel VOAs present inside the 32WSS
- Operating in Power Control Mode with the specific power setpoint designed by Cisco MetroPlanner.

Figure 4-20 System Tilt Compensation With an ROADM Node

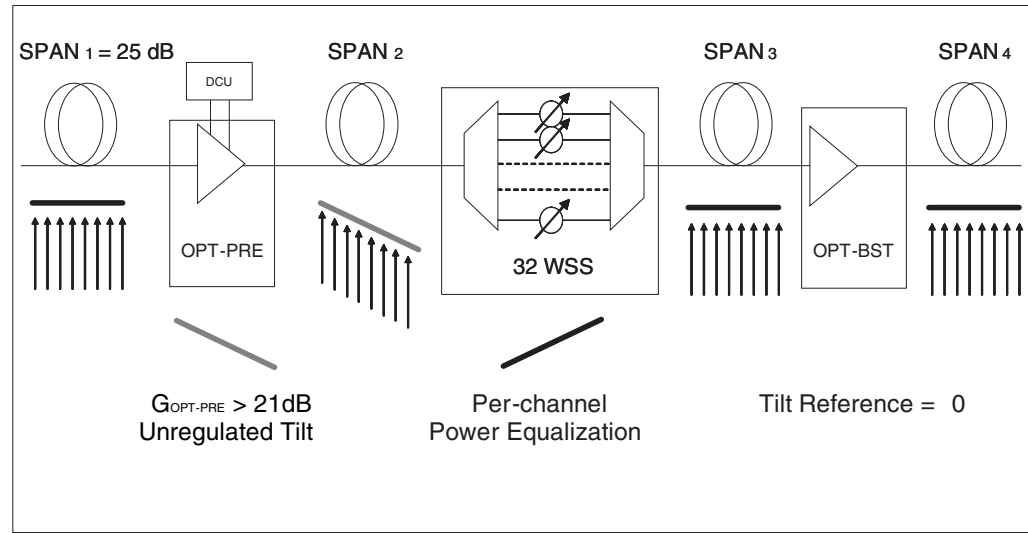

194397

4.9 Optical Channel Circuits

The ONS 15454 DWDM optical circuits provide end-to-end connectivity using three OCH circuit types:

- Optical Channel Network Connections (OCHNC)
- Optical Channel Client Connections (OCHCC)
- Optical Channel Trails (OCH Trails)

A graphical representation of OCH circuits is shown in Figure 4-21.

Figure 4-21 Optical Channel Circuits

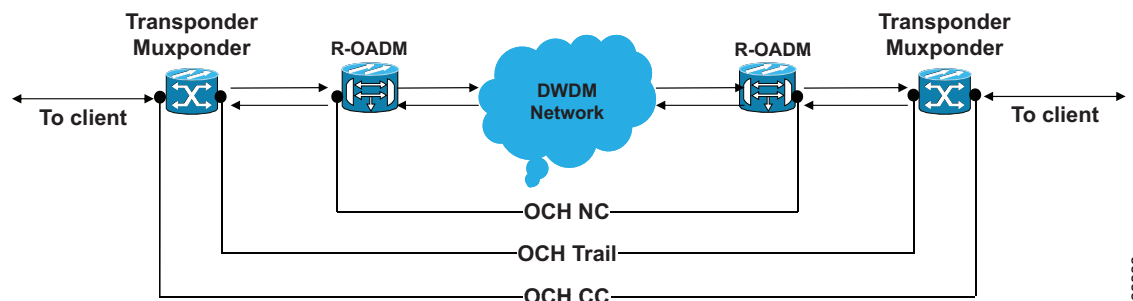

393933

4.9.1 OCHNC Circuits

OCHNC circuits establish connectivity between two optical nodes on a specified C-band wavelength. The connection is made through the ports present on the wavelength selective switches, multiplexers, demultiplexer, and add/drop cards. In an OCHNC circuit, the wavelength from a source OCH port ingresses to a DWDM system and then egresses from the DWDM system to the destination OCH port.

4.9.2 OCHCC Circuits

OCHCC circuits extend the OCHNC to create an optical connection from the source client port to the destination client port of the TXP/MXP cards. An OCHCC circuit represents the actual end-to-end client service passing through the DWDM system.

Each OCHCC circuit is associated to a pair of client or trunk ports on the TXP/MXP card.

The OCHCCs can manage splitter protection as a single protected circuit. However, for the Y-Cable protection, two OCHCC circuits and two protection groups are required.

4.9.3 OCH Trail Circuits

OCH trail circuits transport the OCHCCs. The OCH trail circuit creates an optical connection from the source trunk port to the destination trunk port of the TXP/MXP card. The OCH trail represents the common connection between the two cards, over which all the client OCHCC circuits, SVLAN circuits or STS circuits are carried.

Figure 4-22 shows the relationships and optical flow between the OCHCC, OCH trail, and OCHNC circuits.

Figure 4-22 Optical Channel Management

