



Node Reference

This chapter explains the ONS 15454 dense wavelength division multiplexing (DWDM) node types that are available for the ONS 15454. The DWDM node type is determined by the type of amplifier and filter cards that are installed in an ONS 15454. The chapter also explains the DWDM automatic power control (APC), reconfigurable optical add/drop multiplexing (ROADM) power equalization, span loss verification, and automatic node setup (ANS) functions.



Note

Unless otherwise specified, “ONS 15454” refers to both ANSI and ETSI shelf assemblies.



Note

In this chapter, OPT-BST refers to the OPT-BST, OPT-BST-E, and OPT-BST-L cards, 32WSS refers to the 32WSS and 32WSS-L cards, and 32DMX refers to the 32DMX and 32DMX-L cards (but not the 32-DMX-O card). OPT-PRE refers to both the OPT-PRE card and the OPT-AMP-L card provisioned in OPT-Line mode.



Note

OPT-BST-L, 32WSS-L, 32DMX-L, and OPT-AMP-L cards can only be installed in L-band-compatible nodes and networks. OPT-BST, OPT-BST-E, 32WSS, and 32DMX, cards can only be installed in C-band-compatible nodes and networks.

Chapter topics include:

- [3.1 DWDM Node Configurations, page 3-1](#)
- [3.2 DWDM Node Cabling, page 3-15](#)
- [3.3 DWDM and TDM Hybrid Node Types, page 3-31](#)
- [3.4 Automatic Node Setup, page 3-46](#)

3.1 DWDM Node Configurations

The ONS 15454 supports the following DWDM node configurations: hub, terminal, optical add/drop multiplexing (OADM), ROADM, anti-amplified spontaneous emission (anti-ASE), line amplifier, optical service channel (OSC) regeneration line, and multishelf node.

Single-shelf and multishelf configurations support use of secure mode and locked secure mode. For more information about these options, see the “[Scenario 9: IP Addressing with Secure Mode Enabled](#)” section on page 8-19.

**Note**

The Cisco MetroPlanner tool creates a plan for amplifier placement and proper node equipment.

3.1.1 Hub Node

A hub node is a single ONS 15454 node equipped with two TCC2/TCC2P cards and one of the following combinations:

- Two 32MUX-O cards and two 32DMX-O or 32DMX cards
- Two 32WSS cards and two 32DMX or 32DMX-O cards

**Note**

The 32WSS and 32DMX cards are normally installed in ROADM nodes, but they can be installed in hub and terminal nodes. If the cards are installed in a hub node, the 32WSS express (EXP RX and EXP TX) ports are not cabled.

A dispersion compensation unit (DCU) can also be added, if necessary. [Figure 3-1](#) shows a hub node configuration with 32MUX-O and 32DMX-O cards installed.

**Note**

The OADM AD-xC-xx.x or AD-xB-xx.x cards are not part of a hub node because the 32MUX-O and 32DMX-O cards drop and add all 32 channels; therefore, no other cards are necessary.

Figure 3-1 Hub Node Configuration Example

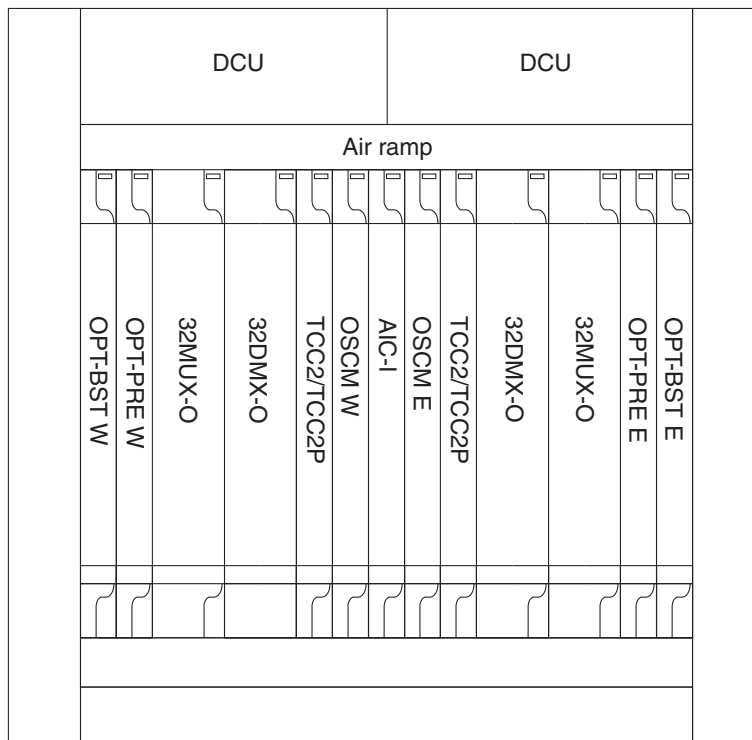
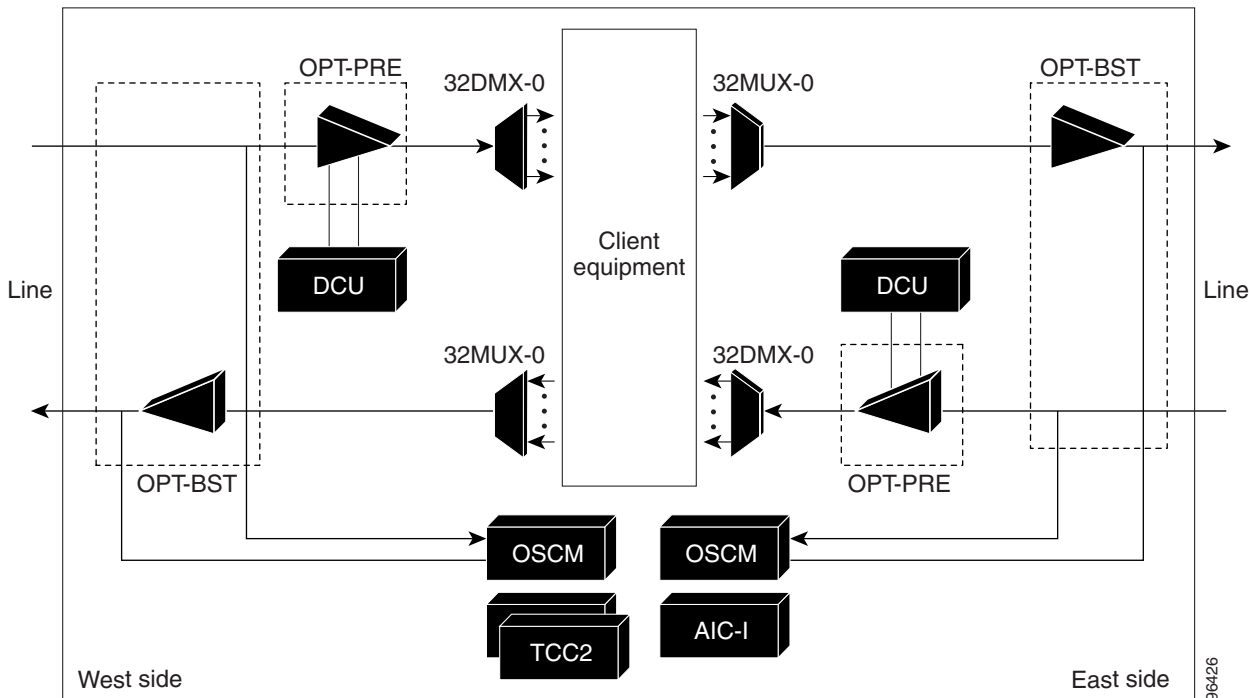

Figure 3-2 shows the channel flow for a hub node. Up to 32 channels from the client ports are multiplexed and equalized onto one fiber using the 32MUX-O card. Then, multiplexed channels are transmitted on the line in the eastward direction and fed to the OPT-BST amplifier. The output of this amplifier is combined with an output signal from the OSCM card and transmitted toward the east line.

Received signals from the east line port are split between the OSCM card and an OPT-PRE card. Dispersion compensation is applied to the signal received by the OPT-PRE amplifier, and it is then sent to the 32DMX-O card, which demultiplexes and attenuates the input signal. The west receive fiber path is identical through the west OPT-BST amplifier, the west OPT-PRE amplifier, and the west 32DMX-O card.

Figure 3-2 Hub Node Channel Flow Example



3.1.2 Terminal Node

A terminal node is a single ONS 15454 node equipped with two TCC2/TCC2P cards and one of the following combinations:

- One 32MUX-O card and one 32DMX-O card
- One 32WSS and either a 32DMX or a 32DMX-O card

Terminal nodes can be either east or west. In west terminal nodes, the cards are installed in the east slots (Slots 1 through 6). In east terminal nodes, cards are installed in the west slots (Slots 12 through 17).

Figure 3-3 shows an example of an east terminal configuration with a 32MUX-O and 32DMX-O cards installed. The channel flow for a terminal node is the same as the hub node (Figure 3-2).

Figure 3-3 Terminal Node Configuration Example

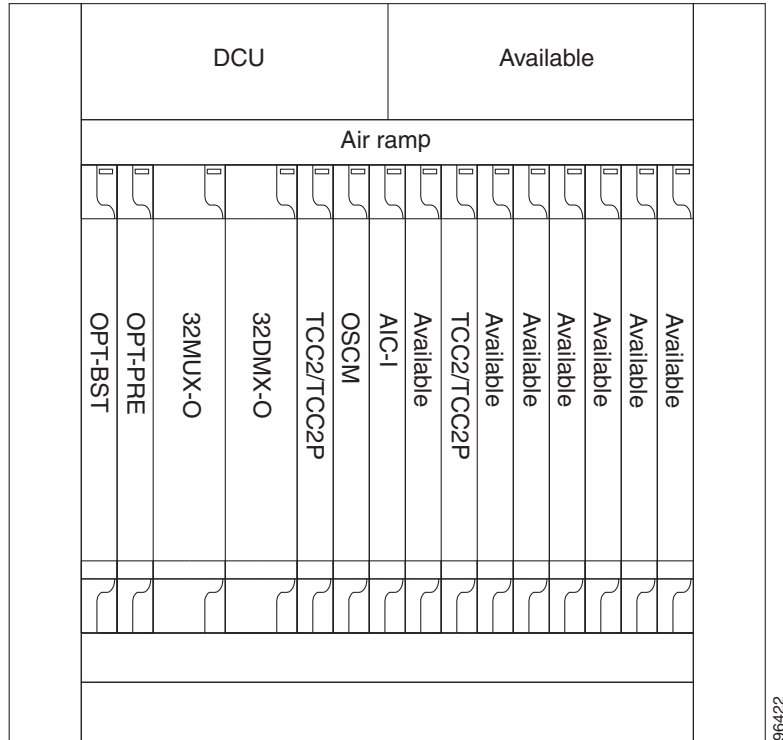

96422

3.1.3 OADM Node

An OADM node is a single ONS 15454 node equipped with cards installed on both sides and at least one AD-xC-xx.x card or one AD-xB-xx.x card and two TCC2/TCC2P cards. 32MUX-O or 32DMX-O cards cannot be installed in an OADM node. In an OADM node, channels can be added or dropped independently from each direction, and then passed through the reflected bands of all OADMs in the DWDM node (called express path). They can also be passed through one OADM card to another OADM card without using a TDM ITU-T line card (called optical pass-through) if an external patchcord is installed.

Unlike express path, an optical pass-through channel can be converted later to an add/drop channel in an altered ring without affecting another channel. OADM amplifier placement and required card placement is determined by the Cisco MetroPlanner tool or your site plan.

OADM nodes can be amplified or passive. In amplified OADMs, the OPT-PRE and the OPT-BST amplifiers are installed on the east and west sides of the node. Figure 3-4 shows an example of an amplified OADM node configuration.

Figure 3-4 Amplified OADM Node Configuration Example

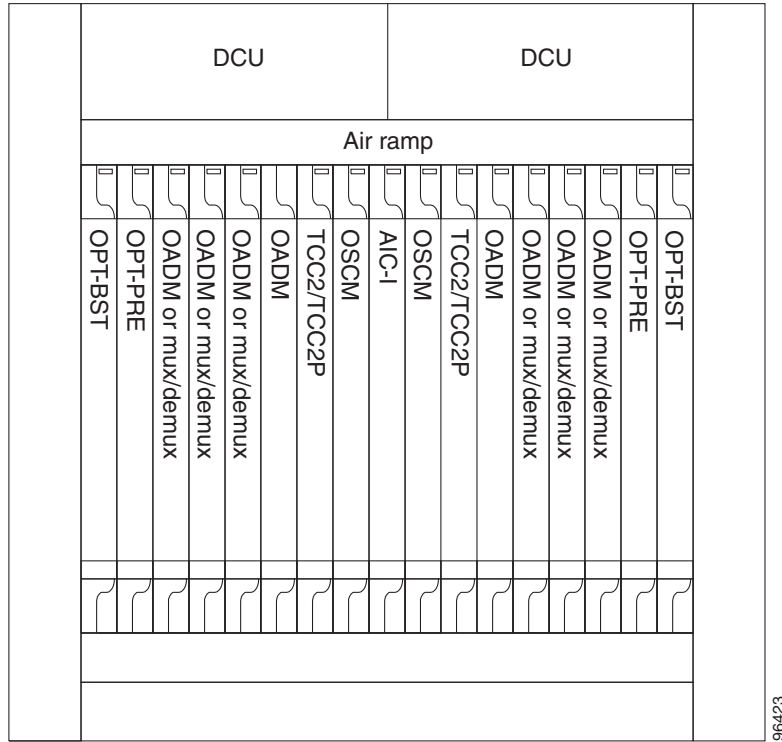

96423

Figure 3-5 shows an example of the channel flow on the amplified OADM node. Since the 32-wavelength plan is based on eight bands (each band contains four channels), optical adding and dropping can be performed at the band level and/or at the channel level (meaning individual channels can be dropped).

Figure 3-5 Amplified OADM Node Channel Flow Example

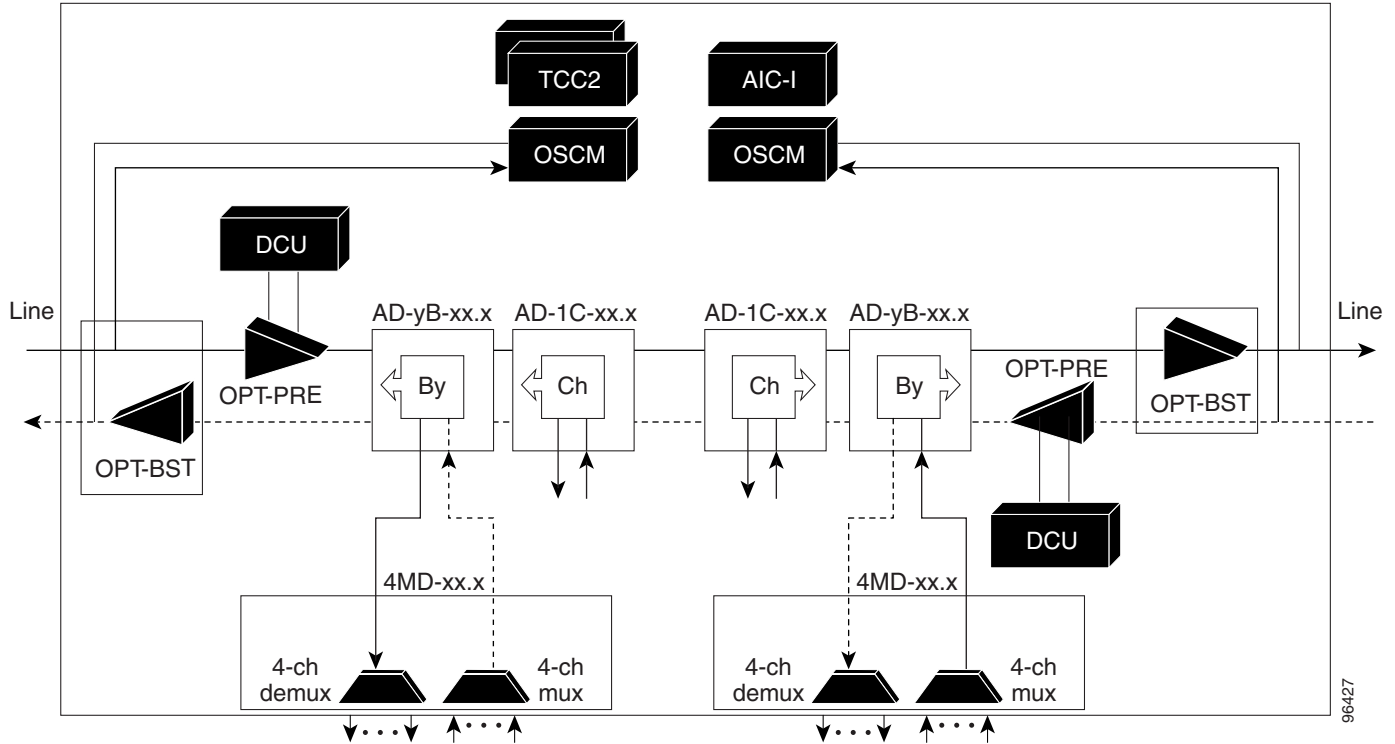

Figure 3-6 shows an example of a passive OADM node configuration. The passive OADM node is equipped with a band filter, one four-channel multiplexer/demultiplexer, and a channel filter on each side of the node.

Figure 3-6 *Passive OADM Node Configuration Example*

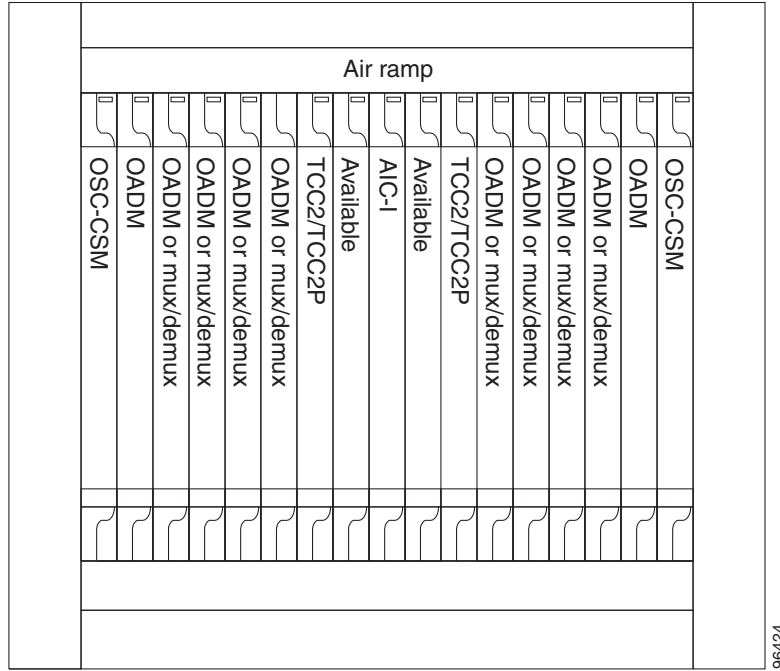
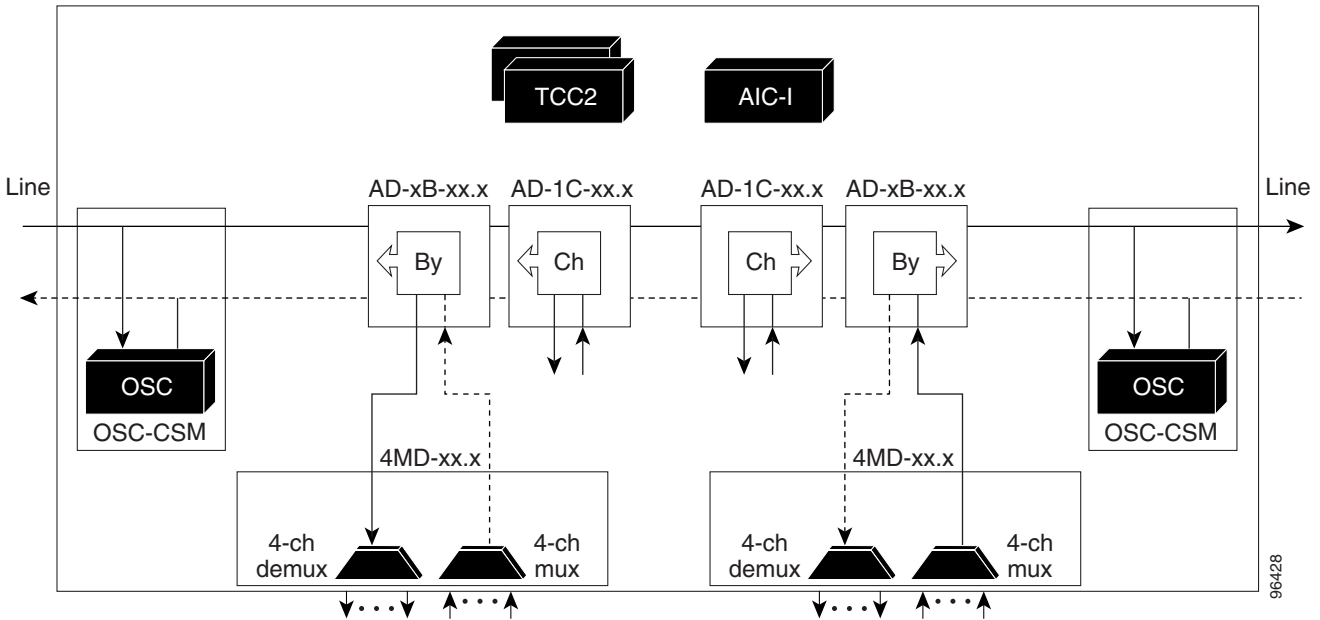

Figure 3-7 shows an example of traffic flow on the passive OADM node. The signal flow of the channels is the same as the amplified OADM, except that the OSC-CSM card is used instead of the OPT-BST amplifier and the OSCM card.

Figure 3-7 *Passive OADM Node Channel Flow Example*



3.1.4 ROADM Node

An ROADM node allows you to add and drop wavelengths without changing the physical fiber connections. ROADM nodes are equipped with two 32WSS cards. 32DMX or 32DMX-O demultiplexers are typically installed, but are not required. Transponders (TXPs) and muxponders (MXPs) can be installed in Slots 6 and 12 and, if amplification is not used, in any open slot. [Figure 3-8](#) shows an example of an amplified ROADM node configuration.

Note

32DMX and 32DMX-O cards can be used in an ROADM node. Cisco Metroplanner automatically chooses the demultiplexer to use for the ROADM node based on the overall network requirements.

Figure 3-8 ROADM Node with OPT-PRE, OPT-BST, and 32DMX Cards Installed

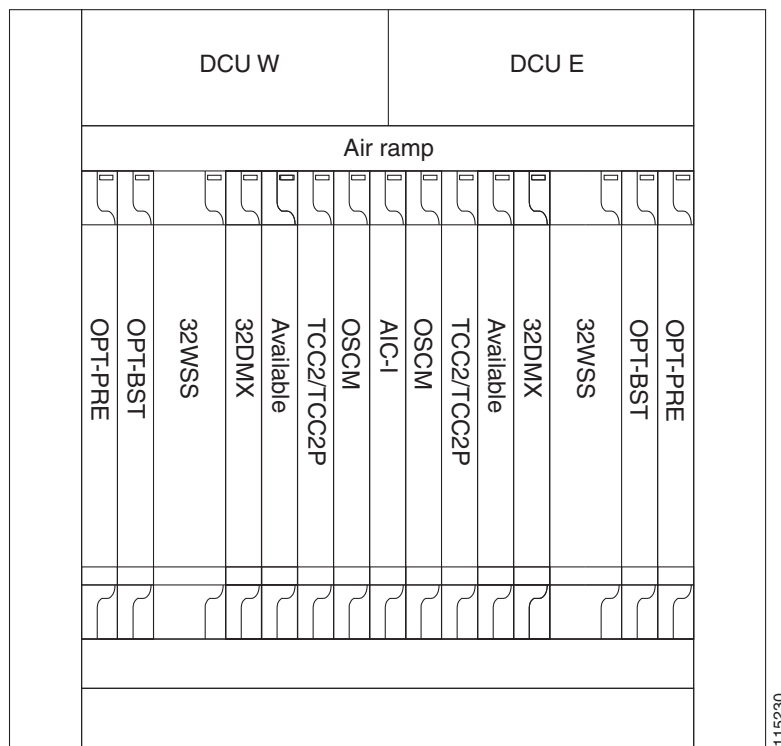

Figure 3-9 shows an example of an ROADM node with 32DMX-O cards installed.

Figure 3-9 ROADM Node with BST-PRE, OPT-BST, and 32DMX-O Cards Installed

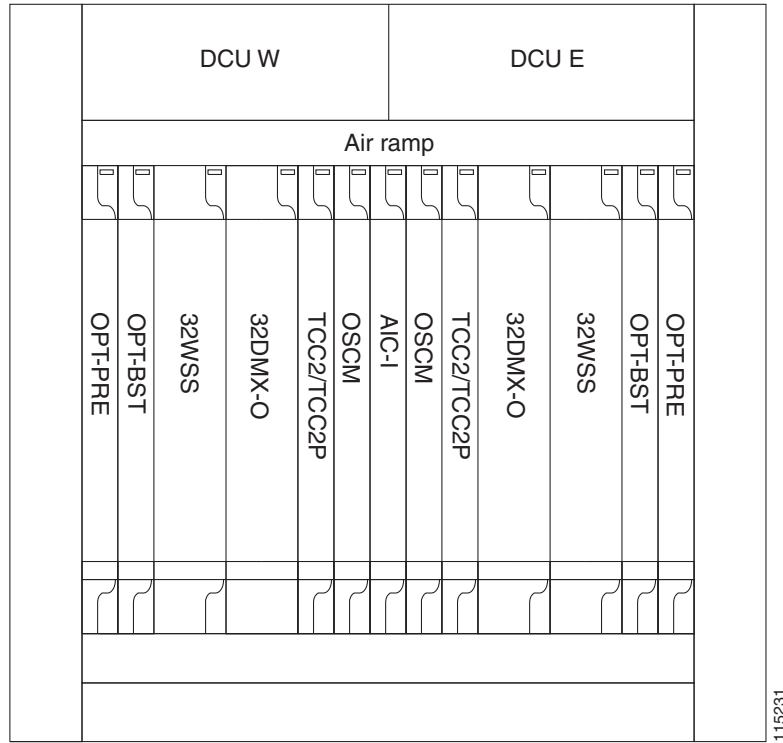
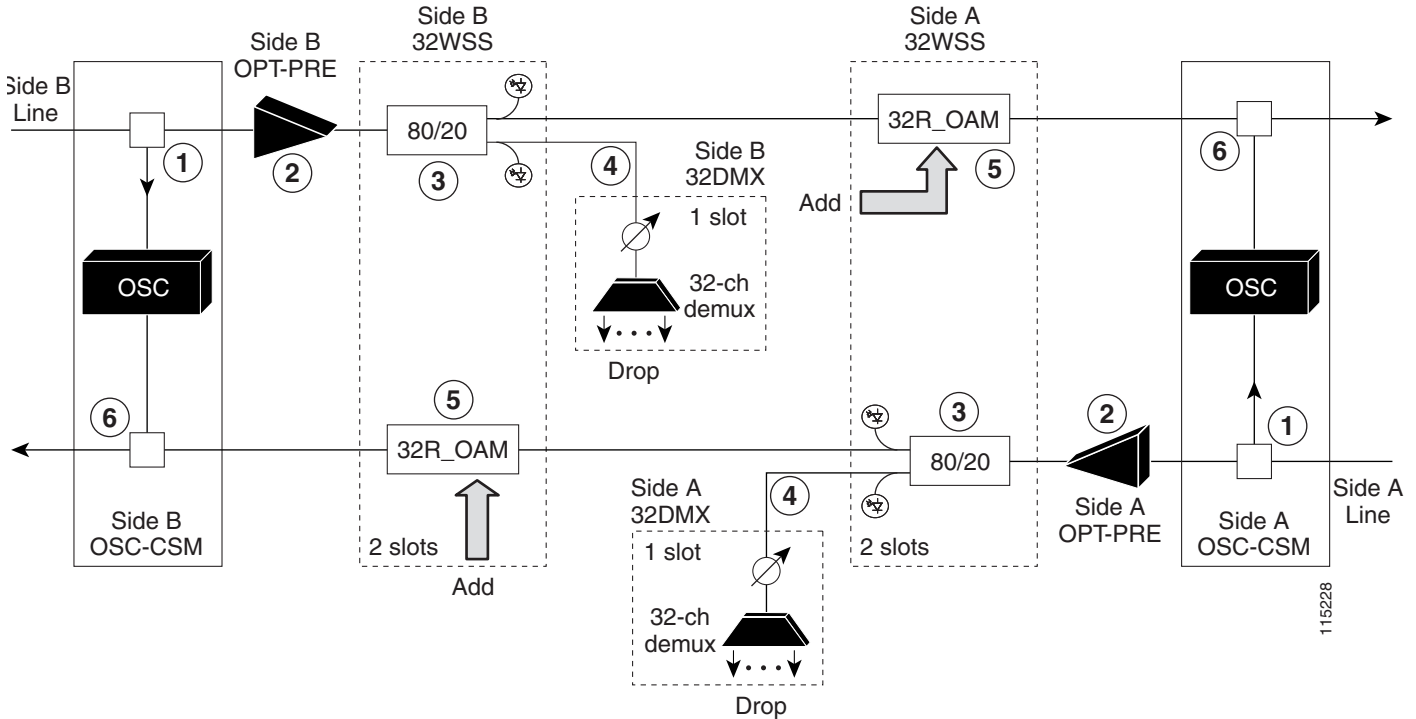

Figure 3-10 shows an example of an ROADM east-to-west optical signal flow. The west-to-east optical signal flow follows an identical path through the west OSC-CSM and west 32WSS modules. In this example, OSC-CSM cards are installed so OPT-BST cards are not needed.

Figure 3-10 ROADM Optical Signal Flow Example



1	The OSC-CSM receives the optical signal. It separates the optical service channel from the optical payload and sends the payload to the OPT-PRE module.
2	The OPT-PRE compensates for chromatic dispersion, amplifies the optical payload, and sends it to the 32WSS.
3	The 32WSS splits the signal into two components. The 80 percent component is sent to the DROP-TX port and the 20 percent component is sent to the EXP-TX port.
4	The drop component goes to the 32DMX where it is demultiplexed and dropped.
5	The express wavelength aggregate signal goes to the 32WSS on the other side where it is demultiplexed. Channels are stopped or forwarded based upon their switch states. Forwarded wavelengths are merged with those coming from the ADD path and sent to the OSC-CSM module.
6	The OSC-CSM combines the multiplexed payload with the OSC and sends the signal out the transmission line.

The MMU card can also be installed in a ROADM node to act as a splitter. Each node will require two MMU cards, one for the east side and one for the west side. The MMU card receives the payload signal on the COM RX port. This signal is split with an 80/20 ratio; 80 percent goes to the EXP TX port. For future use, the remaining 20 percent will go to the EXP-A TX port to allow upgrades to multiring topologies.

3.1.5 Anti-ASE Node

In a meshed ring network, the ONS 15454 requires a node configuration that prevents amplified spontaneous emission (ASE) accumulation and lasing. An anti-ASE node can be created by configuring a hub node or an OADM node with some modifications. No channels can travel through the express path, but they can be demultiplexed and dropped at the channel level on one side and added and multiplexed on the other side.

The hub node is the preferred node configuration when some channels are connected in pass-through mode. For rings that require a limited number of channels, combine AD-xB-xx.x and 4MD-xx.x cards, or cascade AD-xC-xx.x cards. See [Figure 3-5 on page 3-6](#).

[Figure 3-11](#) shows an anti-ASE node that uses all wavelengths in the pass-through mode. Use Cisco MetroPlanner to determine the best configuration for anti-ASE nodes.

Figure 3-11 Anti-ASE Node Channel Flow Example

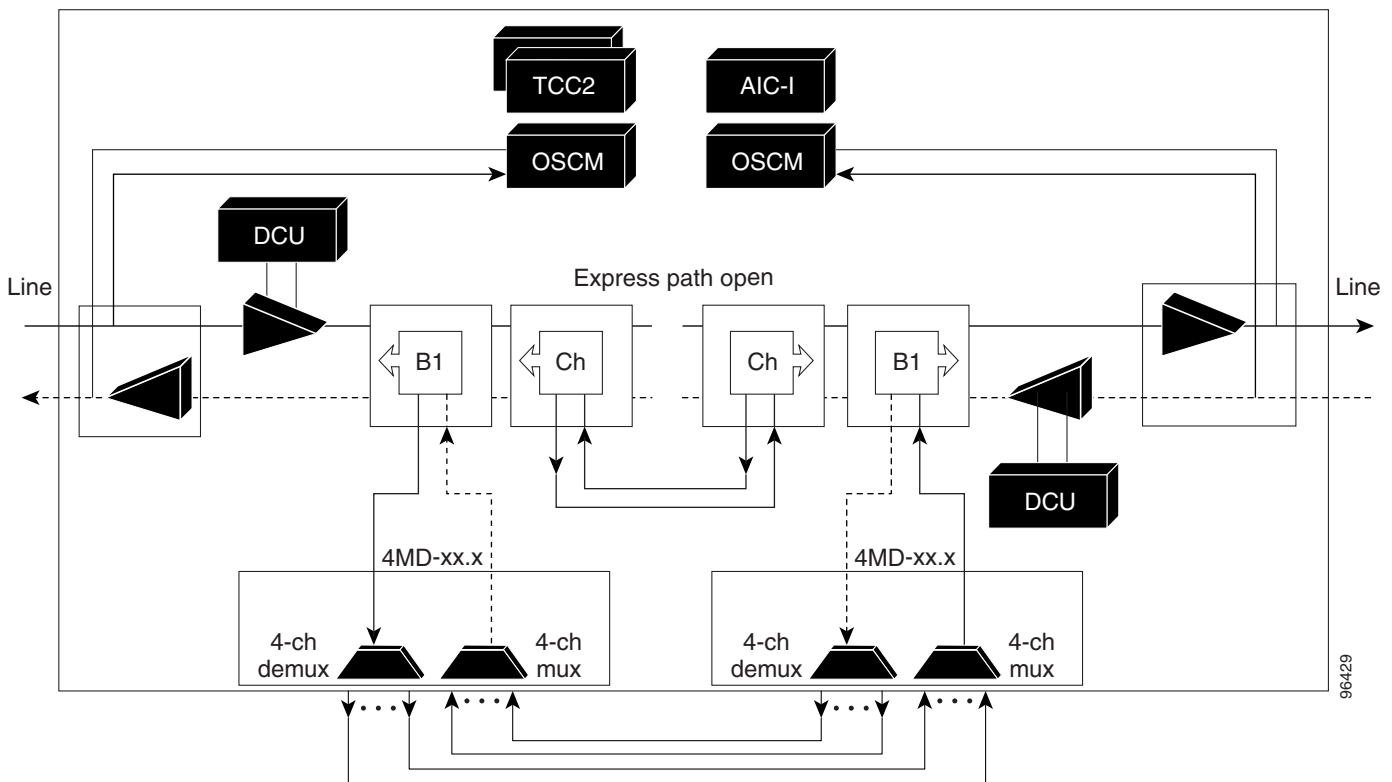

3.1.6 Line Amplifier Node

A line amplifier node is a single ONS 15454 node equipped with OPT-PRE and OPT-BST amplifiers and TCC2/TCC2P cards. Attenuators might also be required between each preamplifier and booster amplifier to match the optical input power value and to maintain the amplifier gain tilt value.

Two OSCM cards are connected to the east or west ports of the booster amplifiers to multiplex the OSC signal with the pass-through channels. If the node does not contain an OPT-BST card, you must use OSC-CSM cards instead of OSCM cards in your configuration. [Figure 3-12](#) shows an example of a line node configuration.

Figure 3-12 Line Amplifier Node Configuration Example

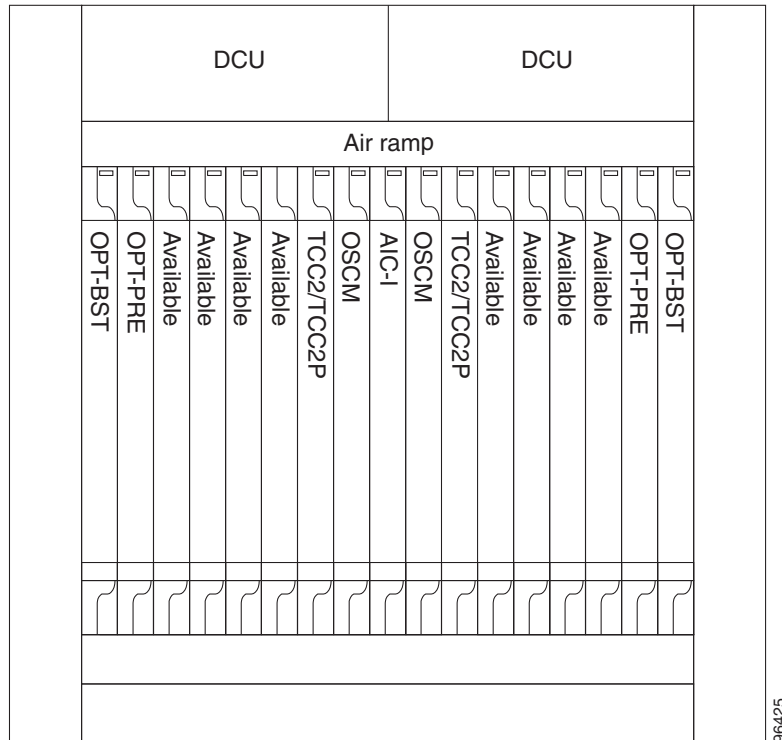

3.1.7 OSC Regeneration Node

The OSC regeneration node is added to the DWDM networks for two purposes:

- To electrically regenerate the OSC channel whenever the span links are 37 dB or longer and payload amplification and add/drop capabilities are not present. Cisco MetroPlanner places an OSC regeneration node in spans longer than 37 dB. 31 dB is the longest span between the OSC regeneration node and the next DWDM network site.
- To add data communications network (DCN) capability wherever needed within the network.

OSC regeneration nodes require two OSC-CSM cards, as shown in [Figure 3-13](#).

Figure 3-13 OSC Regeneration Line Node Configuration Example

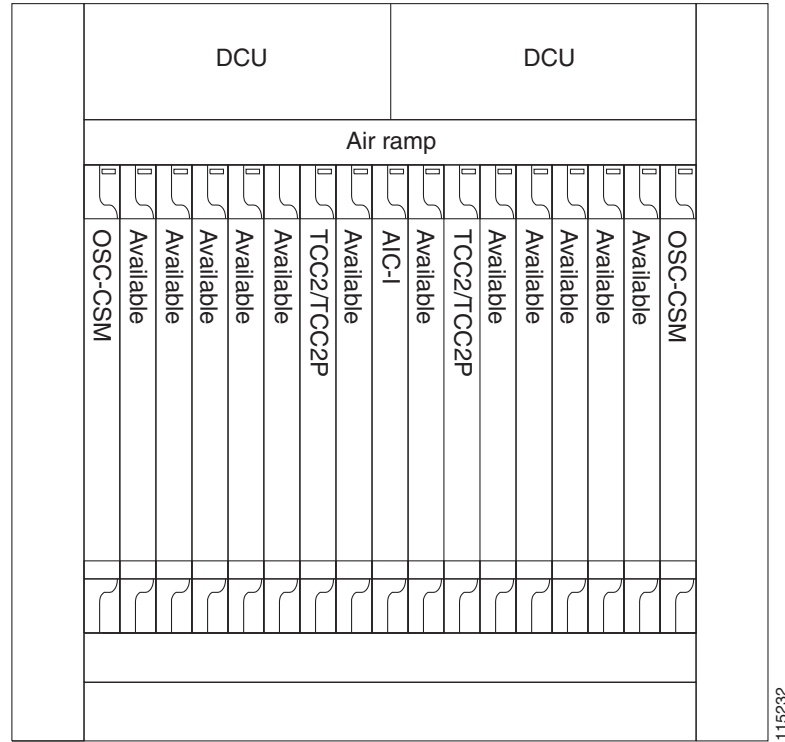
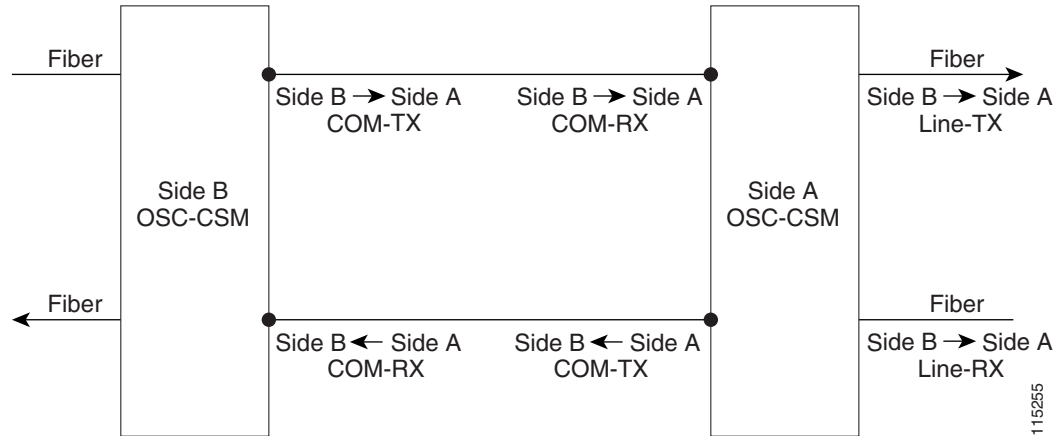

Figure 3-14 shows the OSC regeneration line node OSC signal flow.

Figure 3-14 OSC Regeneration Line Node Flow



3.1.8 Multishelf Node

An ONS 15454 node provisioned as a multishelf node can manage up to 8 subtending shelves as a single entity. The node controller is the main shelf; its TCC2/TCC2P cards run multishelf functions. Each subtending shelf must be equipped with TCC2/TCC2P cards, which run the shelf functions. For internal data exchange between the node controller shelf and subtending shelves, the node controller shelf must

be equipped with redundant MS-ISC-100T cards or, as an alternative, the Catalyst 2950 switch. Cisco recommends using the MS-ISC-100T cards. If using the Catalyst 2950, it is installed on one of multishelf racks. All subtending shelves must be located in the same site at maximum distance of 100 m (metric) from the Ethernet switches used to support the communication LAN.

Figure 3-15 shows an example of the multishelf node configuration.

Figure 3-15 Multishelf Node Configuration

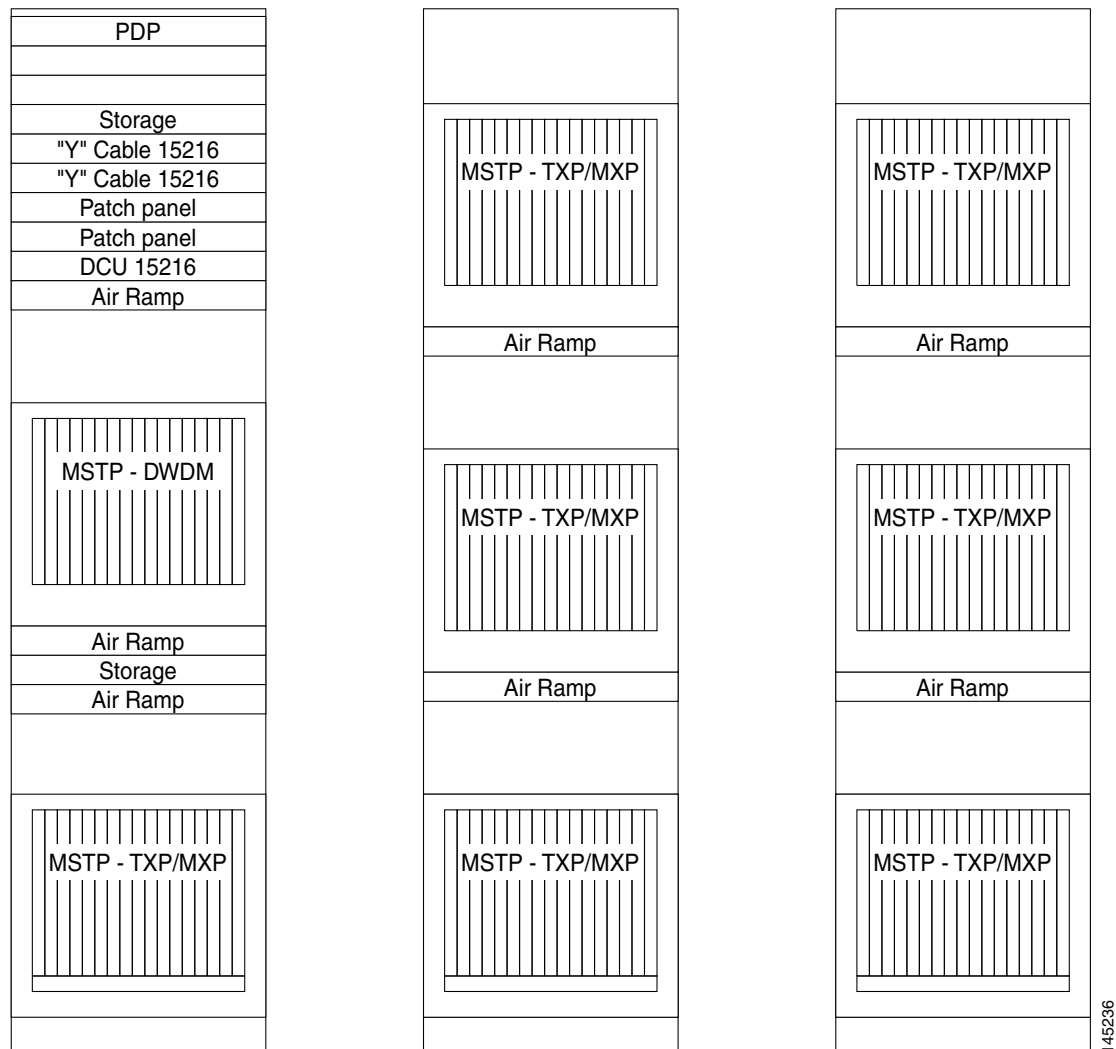

A multishelf node has a single public IP address for all client interfaces (Cisco Transport Controller [CTC], Transaction Language One [TL1], Simple Network Management Protocol [SNMP], and HTTP); a client can only connect to the node controller shelf, not to the subtending shelves. The user interface and subtending shelves are connected to a patch panel using straight-through (CAT-5) LAN cables.

The node controller shelf has the following functions:

- IP packet routing and network topology discovery occur at the node controller level.
- Open Shortest Path First (OSPF) is centralized on the node controller shelf.

The subtending shelves have the following functions:

- Overhead circuits are not routed within a multishelf node but are managed at the subtending controller shelf only. To use overhead bytes, the AIC-I must be installed on the subtending shelf where it is terminated.
- Each subtending shelf will act as a single shelf node that can use as timing source line, TCC/TCC2P clock, or building integrated timing supply (BITS) source lines.

3.1.8.1 Multishelf Node Layout

The recommended multishelf configurations follow. These configurations are supported by Cisco Metroplanner and are automatically discovered by the software.

- Typical installation—All optical units are equipped on the node controller shelf and TXP/MXP cards are equipped in the aggregated subtended shelves. In addition, all empty slots in the node controller shelf can be equipped with TXP/MXP cards.
- East/west protected—All optical cards facing west are equipped in one shelf; all the optical cards facing east are equipped in another shelf.



Note

Patchcords are automatically created only if the TXP/MXP cards have been previously tuned on one of the supported wavelengths.

3.1.8.2 DCC/GCC/OSC Terminations

A multishelf node provides the same communication channels as a single shelf node:

- OSC links terminate on OSCM/OSC-CSM cards. Two links between each ONS 15454 node are required. An OSC link between two nodes cannot be substituted by an equivalent generic communications channel/data communications channel (GCC/DCC) link terminated on the same couple of nodes. OSC links are mandatory and they can be used to connect a node to a gateway network element (GNE).
- GCC/DCC links terminate on TXP/MXP cards.

The maximum number of DCC/GCC/OSC terminations that are supported in a multishelf node is 48.

3.2 DWDM Node Cabling

DWDM node cabling is specified by the Cisco MetroPlanner Internal Connections table. This section provides examples of the cabling you will typically install for each DWDM node types.

3.2.1 OSC Link Termination Fiber-Optic Cabling

- The OPT-BST and OSC-CSM cards are the only cards that directly interface with the line (span) fiber.
- The OSCM card only carries optical service channels, not DWDM channels.
- The OSCM and OSC-CSM cards cannot both be installed on the same side of the shelf (east or west). You can have different cards on each side, for example an OSCM card on the west side and an OSC-CSM card on the east side.

- When an OPT-BST card and an OSC-CSM card are both used on the same side of the node, the OPT-BST card combines the supervision channel with the DWDM channels and the OSC-CSM card acts as an OSCM card; it does not carry DWDM traffic.
- If an OPT-BST and OSCM card are installed on the east side, the east OPT-BST OSC RX port is connected to the east OSCM TX port, and the east OPT-BST OSC TX port is connected to the east OSCM RX port.
- If you have an OPT-BST and OSC-CSM card are installed on the east side, the east OPT-BST OSC RX port is connected to the east OSC-CSM LINE TX port, and the east OPT-BST OSC TX port is connected to the east OSC-CSM LINE RX port.
- If an OPT-BST and OSCM card are installed on the west side, The west OPT-BST OSC TX port is connected to the west OSCM RX port, and the west OPT-BST OSC RX port is connected to the west OSCM TX port.
- If an OPT-BST and OSC-CSM card are installed on the west side, the west OPT-BST OSC TX port is connected to the west OSC-CSM LINE RX port, and the west OPT-BST OSC RX port is connected to the west OSC-CSM LINE TX port.

Figure 3-16 shows an example of OSC fibering for a hub node with OSCM cards installed.

Figure 3-16 *Fibering OSC Terminations—Hub Node with OSCM Cards*

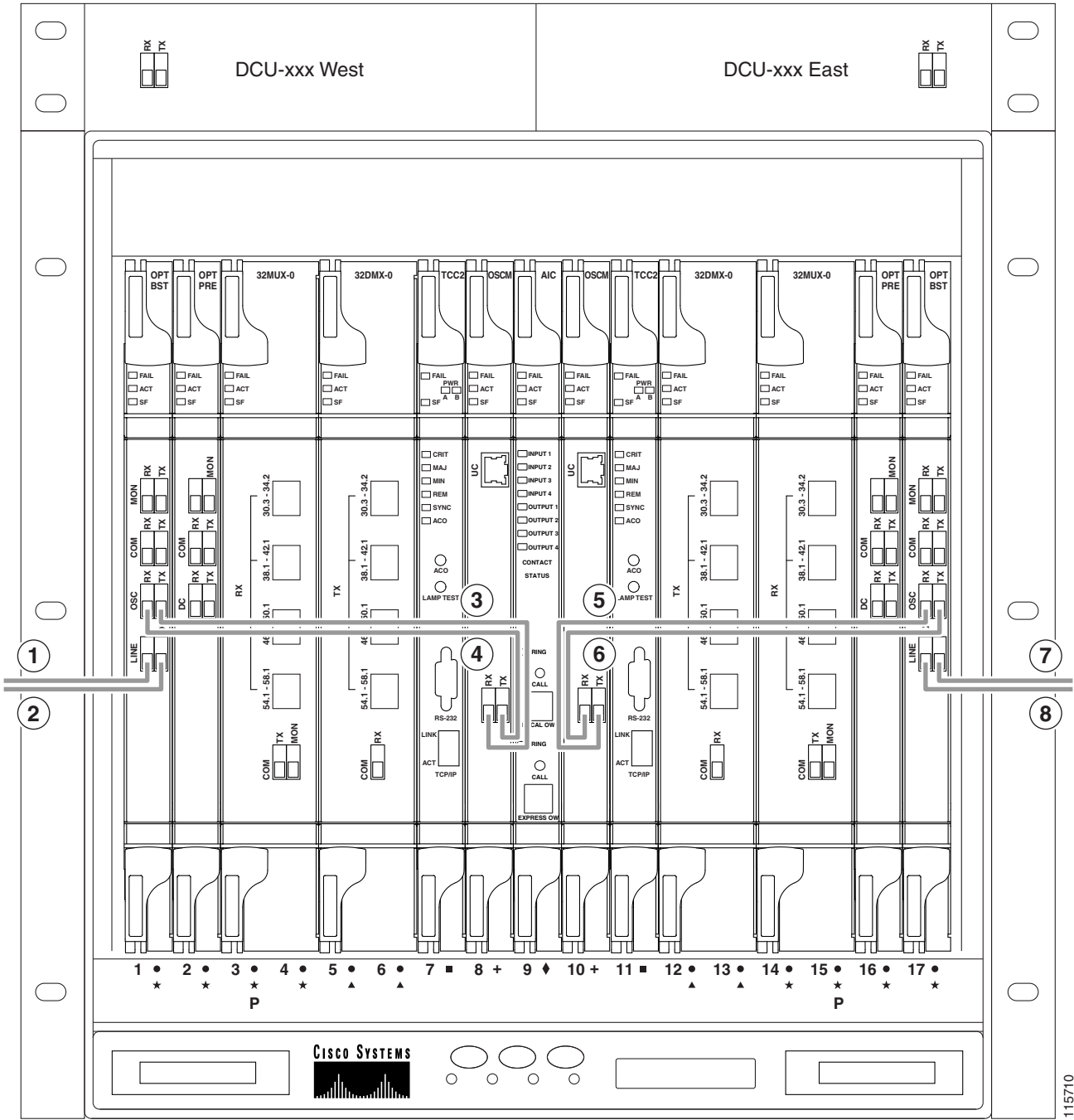

1	West OPT-BST LINE RX to east OPT-BST or OSC-CSM LINE TX on adjacent node	5	East OSCM TX to east OPT-BST OSC RX
----------	--	----------	-------------------------------------

2	West OPT-BST LINE TX to east OPT-BST or OSC-CSM LINE RX on adjacent node	6	East OSCM RX to east OPT-BST OSC TX
3	West OPT-BST OSC TX to west OSCM RX	7	East OPT-BST LINE TX to west OPT-BST or OSC-CSM LINE RX on adjacent node
4	West OPT-BST OSC RX to west OSCM TX	8	East OPT-BST LINE RX to west OPT-BST or OSC-CSM LINE TX on adjacent node

3.2.2 Hub Node Fiber-Optic Cabling

The following rules generally apply to hub node cabling:

- The west OPT-BST or OSC-CSM card common (COM) TX port is connected to the west OPT-PRE COM RX port or the west 32DMX-O COM RX port.
- The west OPT-PRE COM TX port is connected to the west 32DMX-O COM RX port.
- The west 32MUX-O COM TX port is connected to the west OPT-BST or west OSC-CSM COM RX port.
- The east 32MUX-O COM TX port is connected to the east OPT-BST or east OSC-CSM COM RX port.
- The east OPT-BST or east OSC-CSM COM TX port is connected to the east OPT-PRE COM RX port or the east 32DMX-O COM RX port.
- The east OPT-PRE COM TX port is connected to the east 32DMX-O COM RX port.

Figure 3-17 shows an example of a hub node with cabling. In the example, OSCM cards are installed. If OSC-CSM are installed, they are usually installed in Slots 1 and 17.

Figure 3-17 Fiberizing a Hub Node

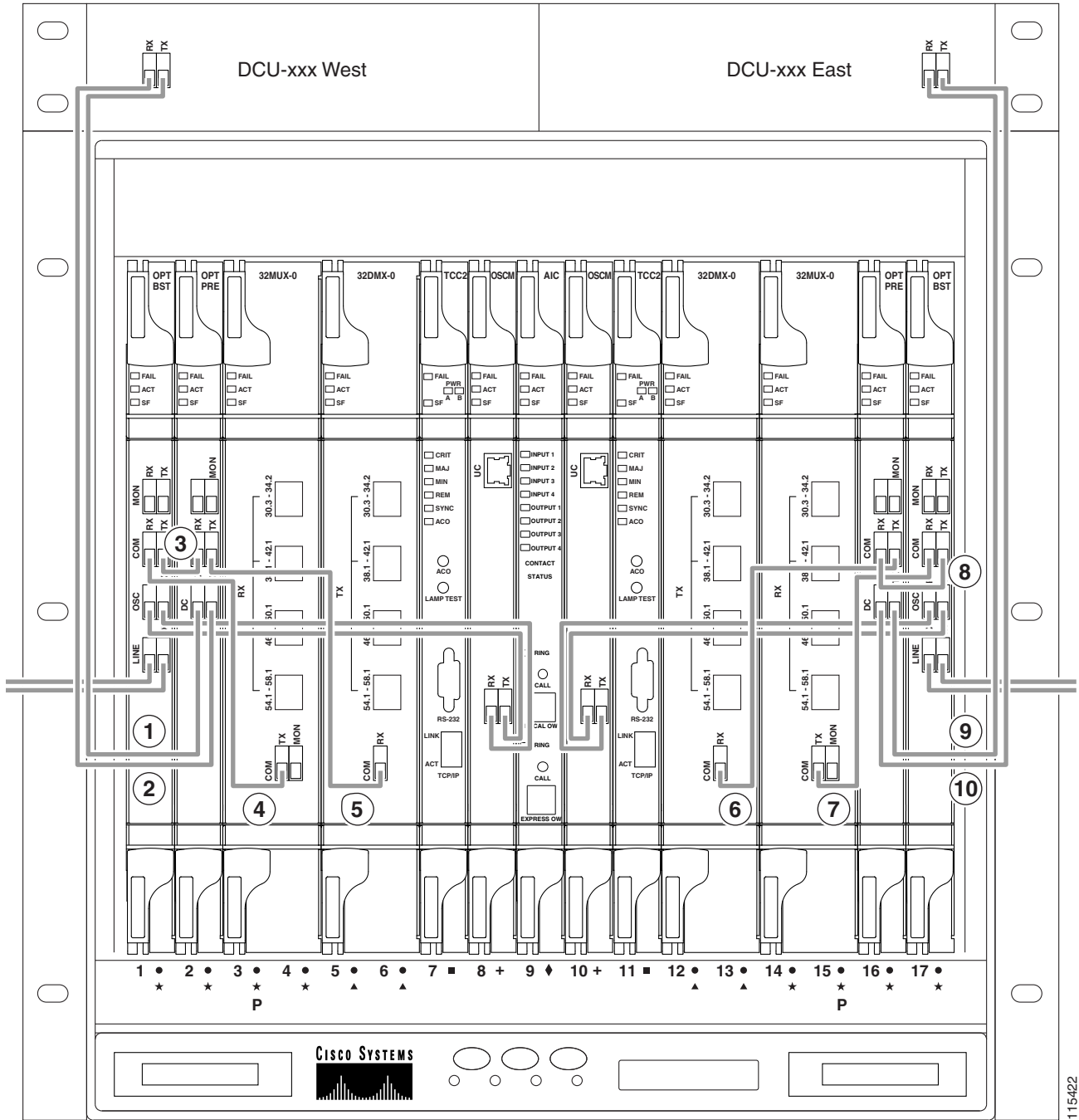

1	West DCU TX to west OPT-PRE DC RX ¹	6	East 32DMX-O COM RX to east OPT-PRE COM TX
2	West DCU RX to west OPT-PRE DC TX ¹	7	East 32MUX-O COM TX to east OPT-BST COM RX
3	West OPT-BST COM TX to west OPT-PRE COM RX	8	East OPT-PRE COM RX to east OPT-BST COM TX
4	West OPT-BST COM RX to west 32MUX-O COM TX	9	East DCU TX to east OPT-PRE DC RX ¹
5	West OPT-PRE COM TX to west 32DMX-O COM RX	10	East DCU RX to east OPT-PRE DC TX ¹

1. If a DCU is not installed, a 4-dB attenuator loop, +/- 1 dB must be installed between the OPT-PRE DC ports.

3.2.3 Terminal Node Fiber-Optic Cabling

The following rules generally apply to terminal node cabling:

- A terminal site has only one side (as compared to a hub node, which has two sides). The terminal side can be either east or west.
- The terminal side OPT-BST or OSC-CSM card COM TX port is connected to the terminal side OPT-PRE COM RX port or the 32DMX-O COM RX port.
- The terminal side OPT-PRE COM TX port is connected to the terminal side 32DMX-O COM RX port.
- The terminal side 32MUX-O COM TX port is connected to the terminal side OPT-BST or OSC-CSM COM RX port.

3.2.4 Line Amplifier Node Fiber-Optic Cabling

The following rules generally apply to line amplifier node cabling:

- Line amplifier node layout allows all combinations of OPT-PRE and OPT-BST cards and allows you to use asymmetrical card choices in west-to-east and east-to-west configurations. For a given line direction, you can configure the four following possibilities:
 - Only preamplification (OPT-PRE)
 - Only booster amplification (OPT-BST)
 - Both preamplification and booster amplification (where a line amplifier node has amplification in at least one direction)
 - Neither preamplification nor booster amplification
- If a west OPT-PRE card is installed:
 - The west OSC-CSM or OPT-BST COM TX is connected to the west OPT-PRE COM RX port.
 - The west OPT-PRE COM TX port is connected to the east OSC-CSM or OPT-BST COM RX port.
- If a west OPT-PRE card is not installed, the west OSC-CSM or the OPT-BST COM TX port is connected to the east OSC-CSM or OPT-BST COM RX port.
- If an east OPT-PRE card is installed:
 - The east OSC-CSM or OPT-BST COM TX port is connected to the east OPT-PRE COM RX port.
 - The east OPT-PRE COM TX port is connected to the west OSC-CSM or OPT-BST COM RX port.
- If an east OPT-PRE card is not installed, the east OSC-CSM or OPT-BST COM TX port is connected to the west OSC-CSM or OPT-BST COM RX port.

Figure 3-18 shows an example of a line amplifier node with cabling.



Note Figure 3-18 is an example. Always install fiber-optic cables based on the Cisco MetroPlanner Internal Connections table for your site.

Figure 3-18 *Fibering a Line Amplifier Node*

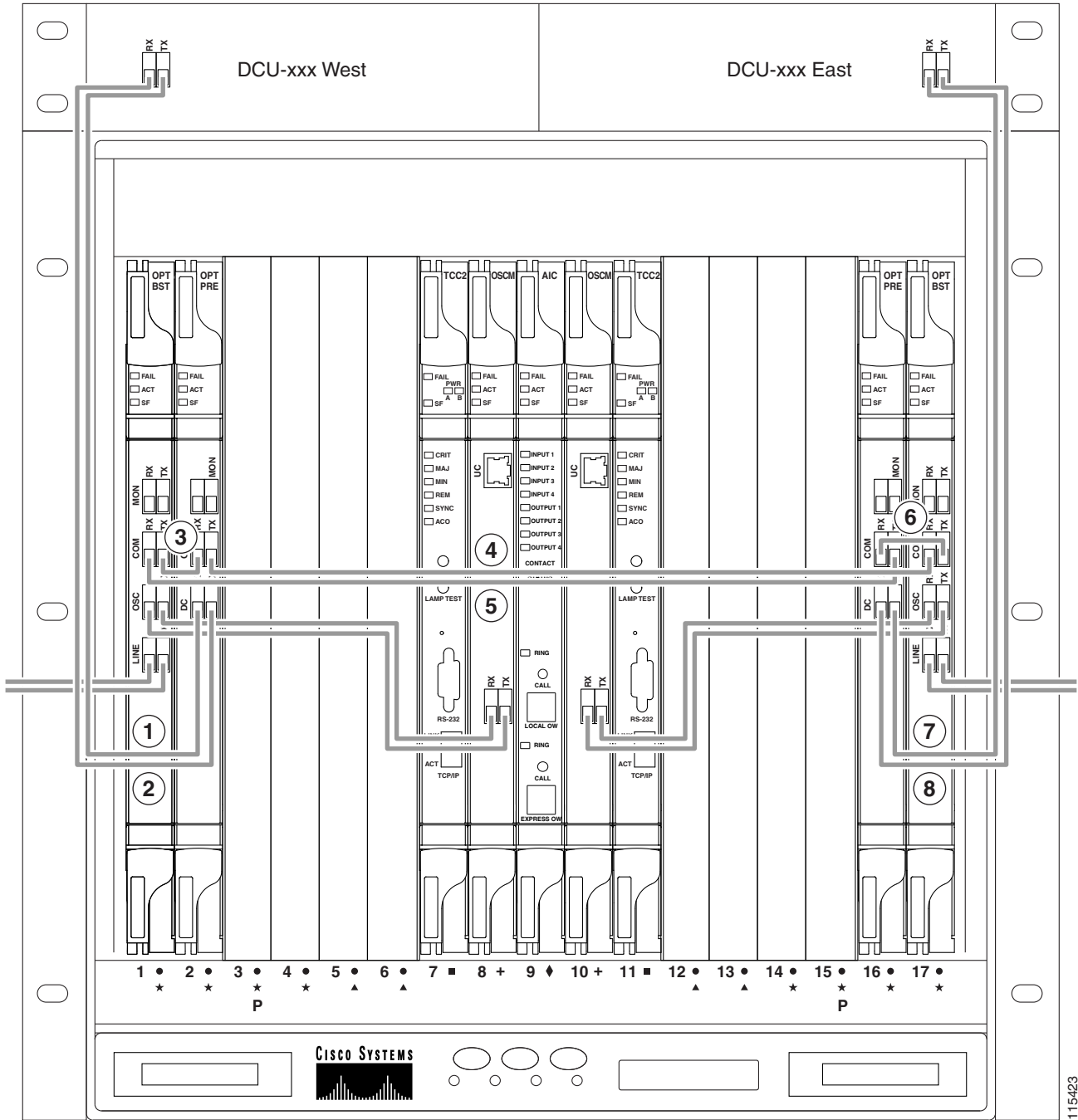

115423

1	West DCU TX to west OPT-PRE DC RX ¹	5	West OPT-BST COM RX to east OPT-PRE COM TX
2	West DCU RX to west OPT-PRE DC TX ¹	6	West OPT-BST COM RX to east OPT-PRE COM TX
3	West OPT-BST COM TX to west OPT-PRE COM RX	7	East DCU TX to east OPT-PRE DC RX ¹
4	West OPT-PRE COM TX to east OPT-BST COM RX	8	East DCU RX to east OPT-PRE DC TX ¹

1. If a DCU is not installed, a 4-dB attenuator loop, +/- 1dB must be installed between the OPT-PRE DC ports.

3.2.5 OSC Regeneration Node Fiber-Optic Cabling

The following rules generally apply to OSC regeneration node cabling:

- The west OSC-CSM COM TX port connects to the east OSC-CSM COM RX port.
- The west OSC-CSM COM RX port connects to the east OSC-CSM COM TX port.
- Slots 2 through 5 and 12 through 16 can be used for TXP and MXP cards.

[Figure 3-19](#) shows an example of an OSC regeneration node with cabling.

Figure 3-19 Fiberizing an OSC Regeneration Node

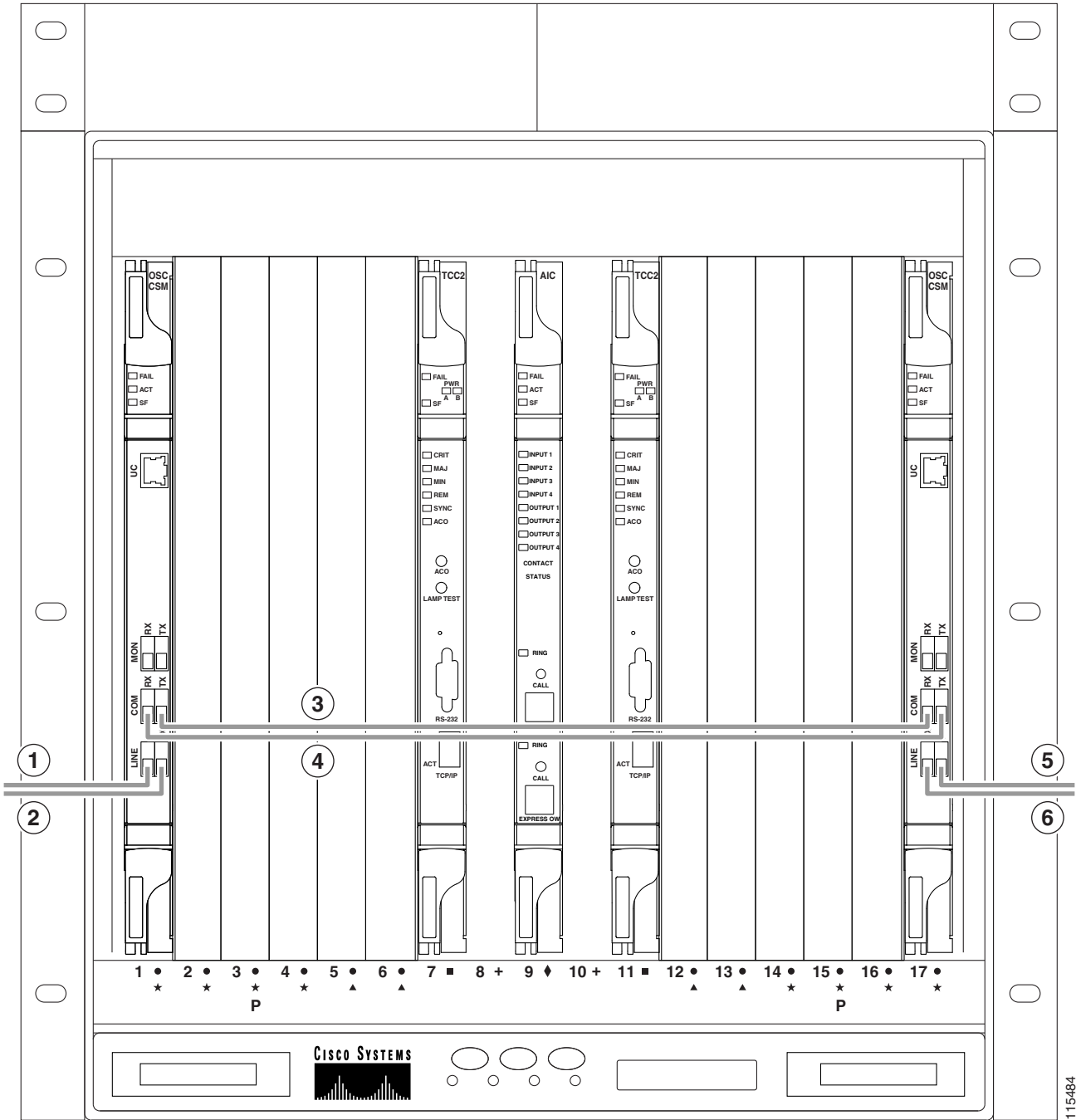

115484

<p>1 West OSC-CSM LINE RX to east OSC-CSM or OPT-BST LINE TX on adjacent node</p>	<p>4 West OSC-CSM COM RX to east OSC-CSM COM TX</p>
<p>2 West OSC-CSM LINE TX to east OSC-CSM or OPT-BST LINE RX on adjacent node</p>	<p>5 East OSC-CSM LINE RX to west OSC-CSM or OPT-BST LINE TX on adjacent node</p>
<p>3 West OSC-CSM COM TX to east OSC-CSM COM RX</p>	<p>6 East OSC-CSM LINE TX to west OSC-CSM or OPT-BST LINE RX on adjacent node</p>

3.2.6 Amplified or Passive OADM Node Fiber-Optic Cabling

The two sides of the OADM node do not need to be symmetrical. On each side, Cisco MetroPlanner can create one of the following four configurations:

- OPT-BST and OPT-PRE
- OSC-CSM and OPT-PRE
- Only OSC-CSM
- Only OPT-BST



Note

Amplified OADM nodes contain OPT-PRE cards and/or OPT-BST cards. Passive OADM nodes do not. Both contain add/drop channel or band cards.

The following rules generally apply for OADM node express path cabled connections:

- TX ports should only be connected to RX ports.
- EXP ports are connected only to COM ports in between AD-xC-xx.x or AD-xB-xx.x cards that all belong to the east side (that is, they are daisy-chained).
- EXP ports are connected only to COM ports in between AD-xC-xx.x or AD-xB-xx.x cards that all belong to the west side (that is, they are daisy-chained).
- The EXP port of the last AD-xC-xx.x or AD-xB-xx.x card on the west side is connected to the EXP port of the first AD-xC-xx.x or AD-xB-xx.x card on the east side.
- The OPT-BST COM RX port is connected to the nearest (in slot position) AD-xC-xx.x or AD-xB-xx.x COM TX port.
- The OPT-PRE COM TX port is connected to the nearest (in slot position) AD-xC-xx.x or AD-xB-xx.x COM RX port.
- If OADM cards are located in adjacent slots, the TCC2/TCC2P card assumes that they are connected in a daisy-chain between the EXP ports and COM ports as noted previously.
- The first west AD-xC-xx.x or AD-xB-xx.x card COM RX port is connected to the west OPT-PRE or OSC-CSM COM TX port.
- The first west AD-xC-xx.x or AD-xB-xx.x card COM TX port is connected to the west OPT-BST or OSC-CSM COM RX port.
- The first east AD-xC-xx.x or AD-xB-xx.x card COM RX port is connected to the east OPT-PRE or OSC-CSM COM TX port.
- The first east AD-xC-xx.x or AD-xB-xx.x card COM TX port is connected to the east OPT-BST or OSC-CSM RX port.
- If a west OPT-PRE is present, the west OPT-BST or OSC-CSM COM TX port is connected to the west OPT-PRE COM RX port.
- If an east OPT-PRE is present, the east OPT-BST or OSC-CSM COM TX port is connected to the east OPT-PRE COM RX port.

The following rules generally apply for OADM node add/drop path cabled connections:

- AD-xB-xx.x add/drop (RX or TX) ports are only connected to the following ports:
 - 4MD-xx.x COM TX or 4MD-xx.x COM RX ports
 - Another AD-xB-xx.x add/drop port (a pass-through configuration)

- An AD-xB-xx.x add/drop band port is only connected to a 4MD-xx.x card belonging to the same band.
- For each specific AD-xB-xx.x card, the add and drop ports for that band card are connected to the COM TX and COM RX ports of the same 4MD-xx.x card.
- The AD-xB-xx.x and 4MD-xx.x cards are located in the same side (the connected ports all have the same line direction).

The following rules generally apply for OADM node pass-through path cabled connections:

- Pass-through connections are only established between add and drop ports on the same band or channel and in the same line direction.
- Only connect AD-xC-xx.x or AD-xB-xx.x add/drop ports to other AD-xC-xx.x or AD-xB-xx.x add/drop ports (as pass-through configurations).
- An add (RX) port is only connected to a drop (TX) port.
- Only connect 4MD-xx.x client input/output ports to other 4MD-xx.x client input/output ports.
- A west AD-xB-xx.x drop (TX) port is connected to the corresponding west 4MD-xx.x COM RX port.
- A west AD-xB-xx.x add (RX) port is connected to the corresponding west 4MD-xx.x COM TX port.
- An east AD-xB-xx.x drop (TX) port is connected to the corresponding east 4MD-xx.x COM RX port.
- An east AD-xB-xx.x add (RX) port is connected to the corresponding east 4MD-xx.x COM TX port.

Figure 3-20 shows an example of an amplified OADM node with AD-1C-xx.x cards installed.



Note Figure 3-20 is an example. Always install fiber-optic cables based on the Cisco MetroPlanner Internal Connections table for your site.

3.2.6 Amplified or Passive OADM Node Fiber-Optic Cabling

Figure 3-20 Fiberling an Amplified OADM Node

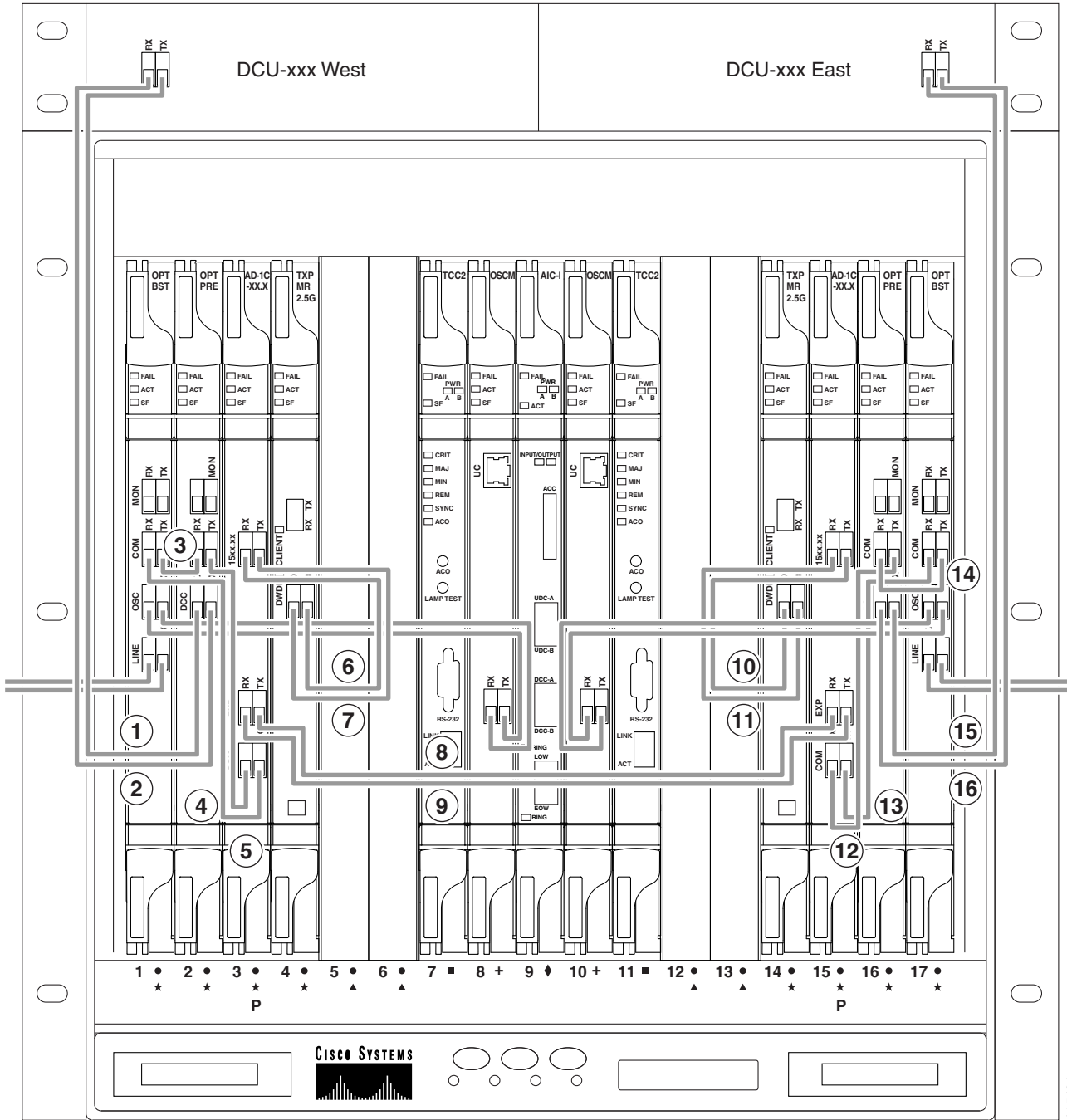

1	West DCU TX to west OPT-PRE DC RX ¹	9	West AD-1C-xx.x EXP RX to east AD-1C-xx.x EXP TX
2	West DCU RX to west OPT-PRE DC TX ¹	10	East TXP_MR_2.5G DWDM RX to east AD-1C-xx.x (15xx.xx) TX
3	West OPT-BST COM TX to west OPT-PRE COM RX	11	East TXP_MR_2.5G DWDM TX to east AD-1C-xx.x (15xx.xx) RX

4	West OPT-BST COM RX to west AD-1C-xx.x COM TX	12	East AD-1C-xx.x COM RX to OPT-PRE COM TX
5	West OPT-PRE COM TX to west AD-1C-xx.x COM RX	13	East AD-1C-xx.x COM TX to OPT-BST COM RX
6	West AD-1C-xx.x (15xx.xx) RX to west TXP_MR_2.5G DWDM TX	14	East OPT-PRE COM RX to east OPT-BST COM TX
7	West AD-1C-xx.x (15xx.xx) TX to west TXP_MR_2.5G DWDM RX	15	East DCU TX to east OPT-PRE DC RX ¹
8	West AD-1C-xx.x EXP TX to east AD-1C-xx.x EXP RX	16	East DCU RX to east OPT-PRE DC TX ¹

1. If a DCU is not installed, a 4-dB attenuator loop, +/-1 dB must be installed between the OPT-PRE DC ports.

Figure 3-21 shows an example of a passive OADM node with two AD-1C-xx.x cards installed.

Figure 3-21 Fiberng a Passive OADM Node

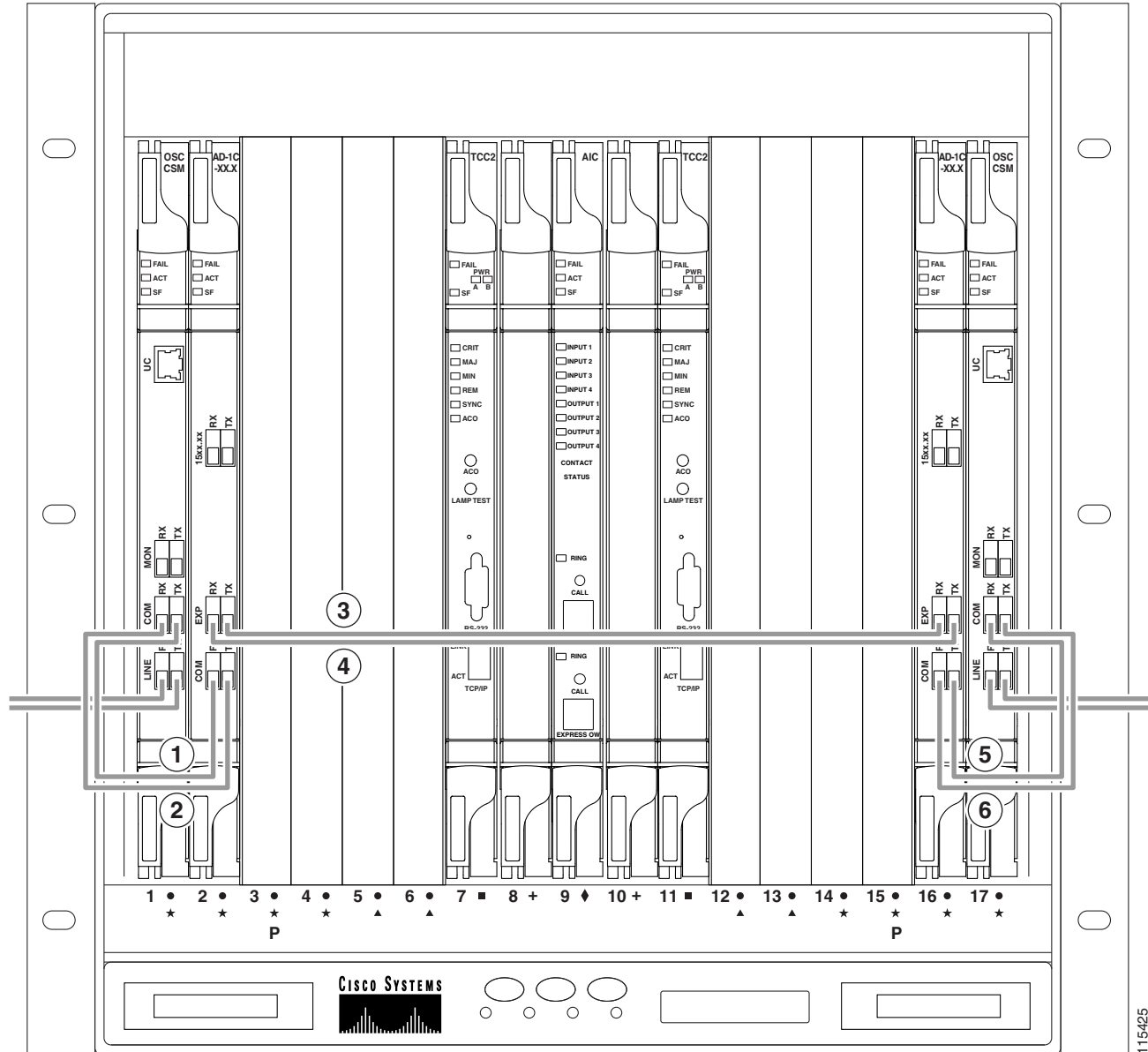

1	West OSC-CSM COM TX to west AD-1C-xx.x COM RX	4	West OSC-CSM EXP RX to east AD-1C-xx.x EXP TX
2	West OSC-CSM COM RX to west AD-1C-xx.x COM TX	5	East AD-1C-xx.x COM TX to east OSC-CSM COM RX
3	West OSC-CSM EXP TX to east AD-1C-xx.x EXP RX	6	East AD-1C-xx.x COM RX to east OSC-CSM COM TX

3.2.7 ROADM Node Fiber-Optic Cabling

The following rules generally apply to ROADM node cabling:

- The west OPT-BST or OSC-CSM COM TX port is connected to the west OPT-PRE COM RX port.
- The west OPT-PRE COM TX port is connected to the west 32WSS COM RX port.
- The west OPT-BST or OSC-CSM COM RX port is connected to the west 32WSS COM TX port.
- The west OPT-BST (if installed) OSC TX port is connected to the west OSCM RX port.
- The west OPT-BST (if installed) OSC RX port is connected to the west OSCM TX port.
- The west 32WSS EXP TX port is connected to the east 32WSS EXP RX port.
- The west 32WSS EXP RX port is connected to the east 32WSS EXP TX port.
- The west 32WSS DROP TX port is connected to the west 32DMX COM RX port.
- The east OPT-BST or OSC-CSM COM TX port is connected to the east OPT-PRE COM RX port.
- The east OPT-PRE COM TX port is connected to the east 32WSS COM RX port.
- The east OPT-BST or OSC-CSM COM RX port is connected to the east 32WSS COM TX port.
- The east OPT-BST (if installed) OSC TX port is connected to the east OSCM RX port.
- The east OPT-BST (if installed) OSC RX port is connected to the east OSCM TX port.
- The east 32WSS DROP TX port is connected to the east 32DMX COM RX port.

Figure 3-22 shows an example of an amplified ROADM node with cabling.



Note Figure 3-22 is an example. Always install fiber-optic cables based on the Cisco MetroPlanner Internal Connections table for your site.

3.2.7 ROADM Node Fiber-Optic Cabling

Figure 3-22 Fiber-ing an ROADM Node

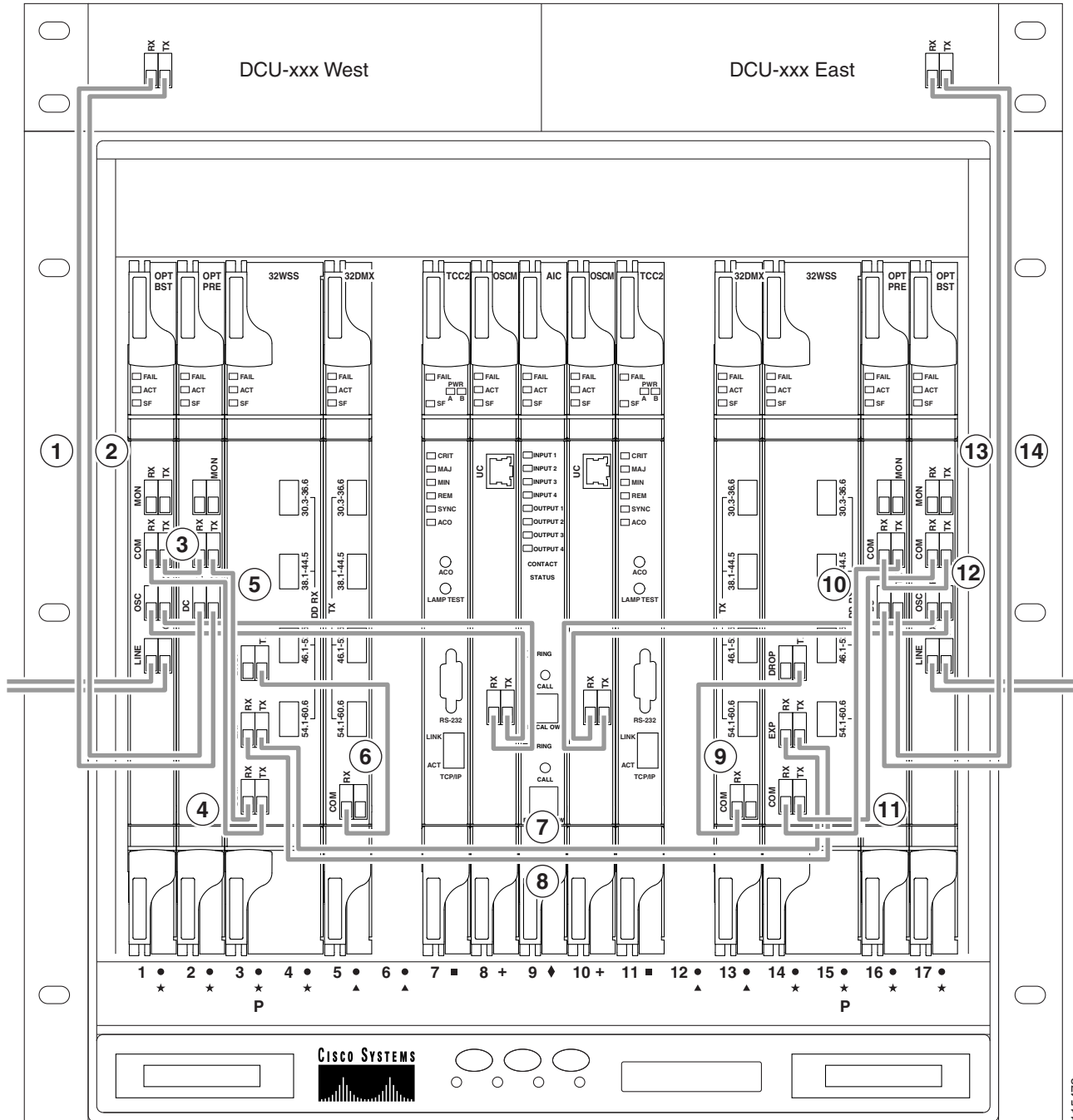

115473

1	West DCU TX to west OPT-PRE DC RX ¹	8	West 32WSS EXP RX to east 32WSS EXP TX
2	West DCU RX to west OPT-PRE DC TX ¹	9	East 32DMX COM RX to east 32WSS DROP TX
3	West OPT-BST COM TX to west OPT-PRE COM RX	10	East 32WSS COM RX to east OPT-PRE COM TX
4	West 32WSS COM TX to west OPT-BST COM RX	11	East 32WSS COM TX to east OPT-BST COM RX

5	West 32WSS COM RX to west OPT-PRE COM TX	12	East OPT-BST COM TX to east OPT-PRE COM RX
6	West 32DMX COM RX to west 32WSS DROP TX	13	East DCU RX to east OPT-PRE DC TX ¹
7	West 32WSS EXP TX to east 32WSS EXP RX	14	East DCU TX to east OPT-PRE DC RX ¹

1. If a DCU is not installed, a 4-dB attenuator loop, +/-1 dB must be installed between the OPT-PRE DC ports.

3.3 DWDM and TDM Hybrid Node Types

The node type in a network configuration is determined by the type of card that is installed in an ONS 15454 hybrid node. The ONS 15454 supports the following hybrid DWDM and TDM node types: 1+1 protected flexible terminal, scalable terminal, hybrid terminal, hybrid OADM, hybrid line amplifier, and amplified TDM.



Note

The Cisco MetroPlanner tool creates a plan for amplifier placement and proper equipment for DWDM node configurations. Although TDM cards can be used with DWDM node configuration, the Cisco MetroPlanner tool does not create a plan for TDM card placement. Cisco MetroPlanner will support TDM configurations in a future release.

3.3.1 1+1 Protected Flexible Terminal Node

The 1+1 protected flexible terminal node is a single ONS 15454 node equipped with a series of OADM cards acting as a hub node configuration. This configuration uses a single hub or OADM node connected directly to the far-end hub or OADM node through four fiber links. This node type is used in a ring configured with two point-to-point links. The advantage of the 1+1 protected flexible terminal node configuration is that it provides path redundancy for 1+1 protected TDM networks (two transmit paths and two receive paths) using half of the DWDM equipment that is usually required. In the following example (Figure 3-23), one node transmits traffic to the other node on both east and west sides of the ring for protection purposes. If the fiber is damaged on one side of the ring, traffic still arrives safely through fiber on the other side of the ring.

Figure 3-23 Double Terminal Protection Configuration

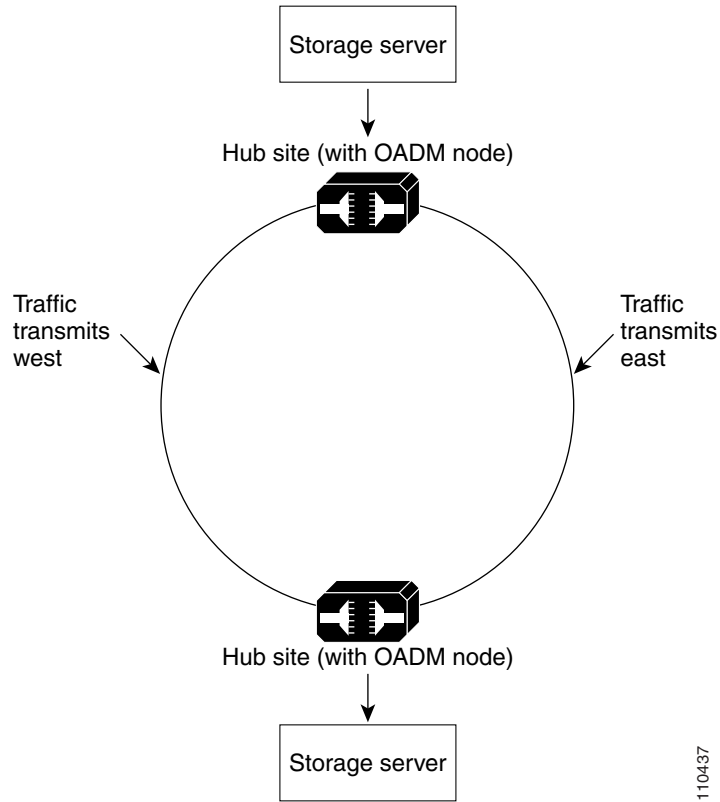

Figure 3-24 shows a 1+1 protected single-span link with hub nodes. This node type cannot be used in a hybrid configuration.

Figure 3-24 1+1 Protected Single-Span Link with Hub Nodes

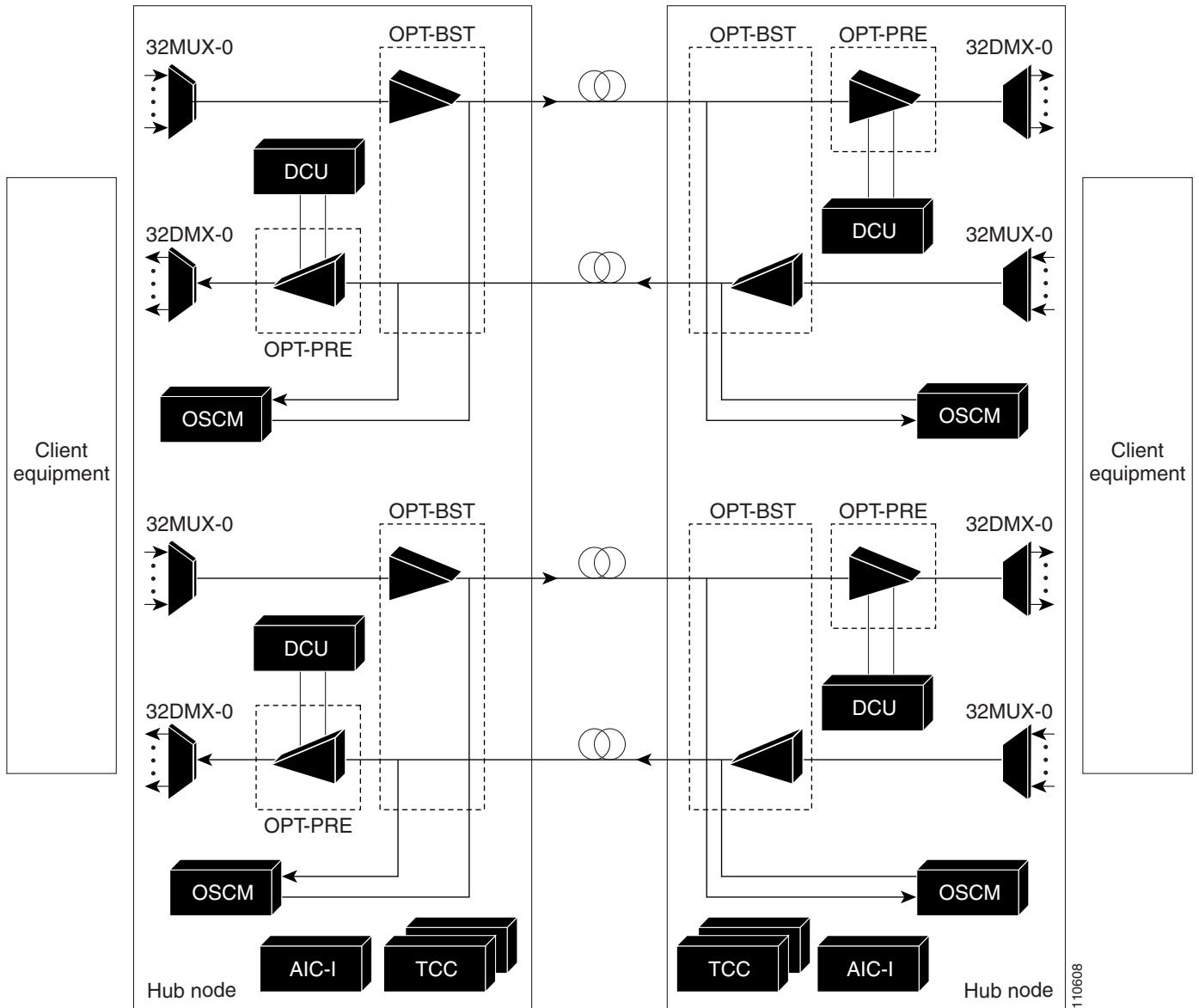

Figure 3-25 shows a 1+1 protected single-span link with active OADM nodes. This node type can be used in a hybrid configuration.

Figure 3-25 1+1 Protected Single-Span Link with Active OADM Nodes

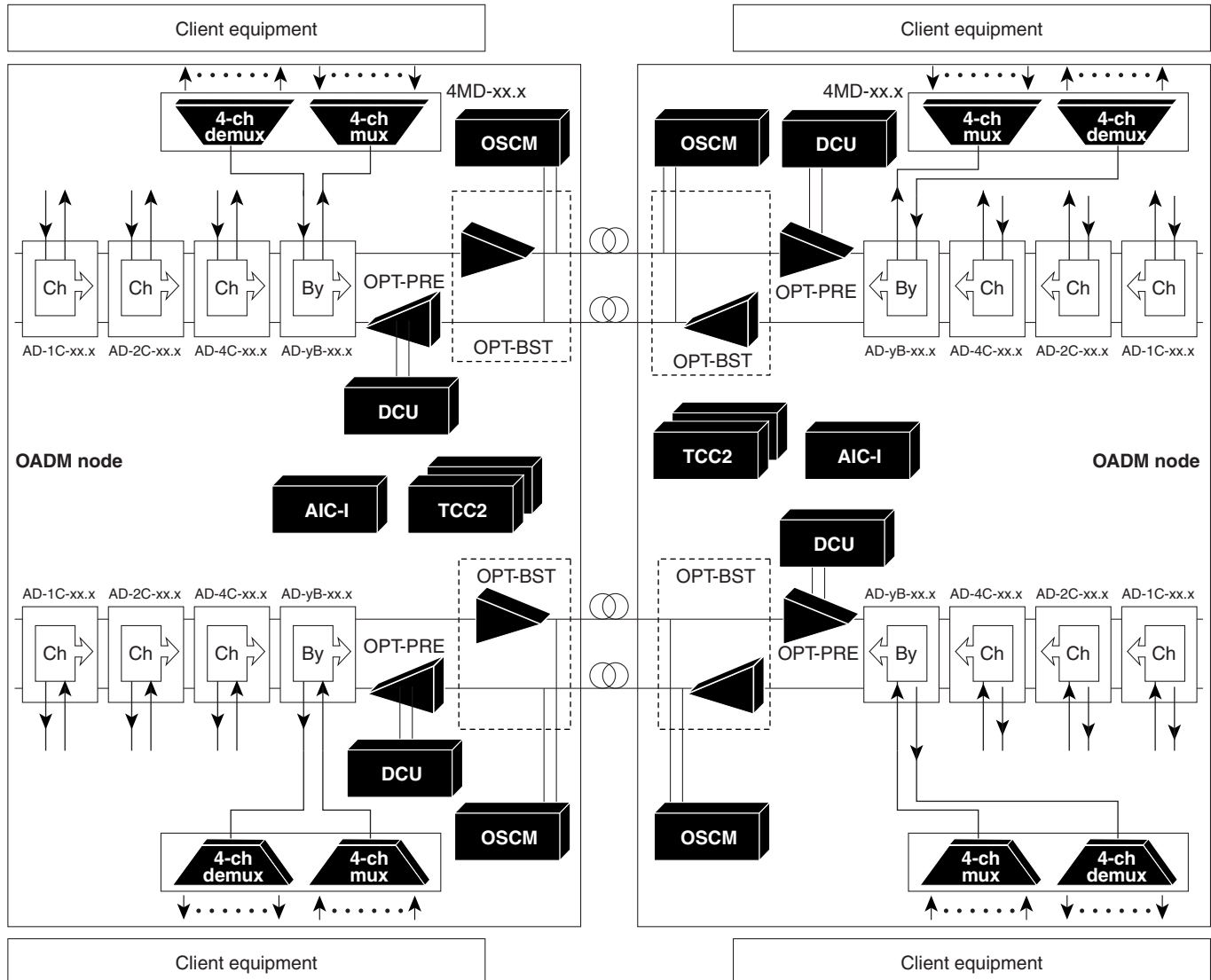
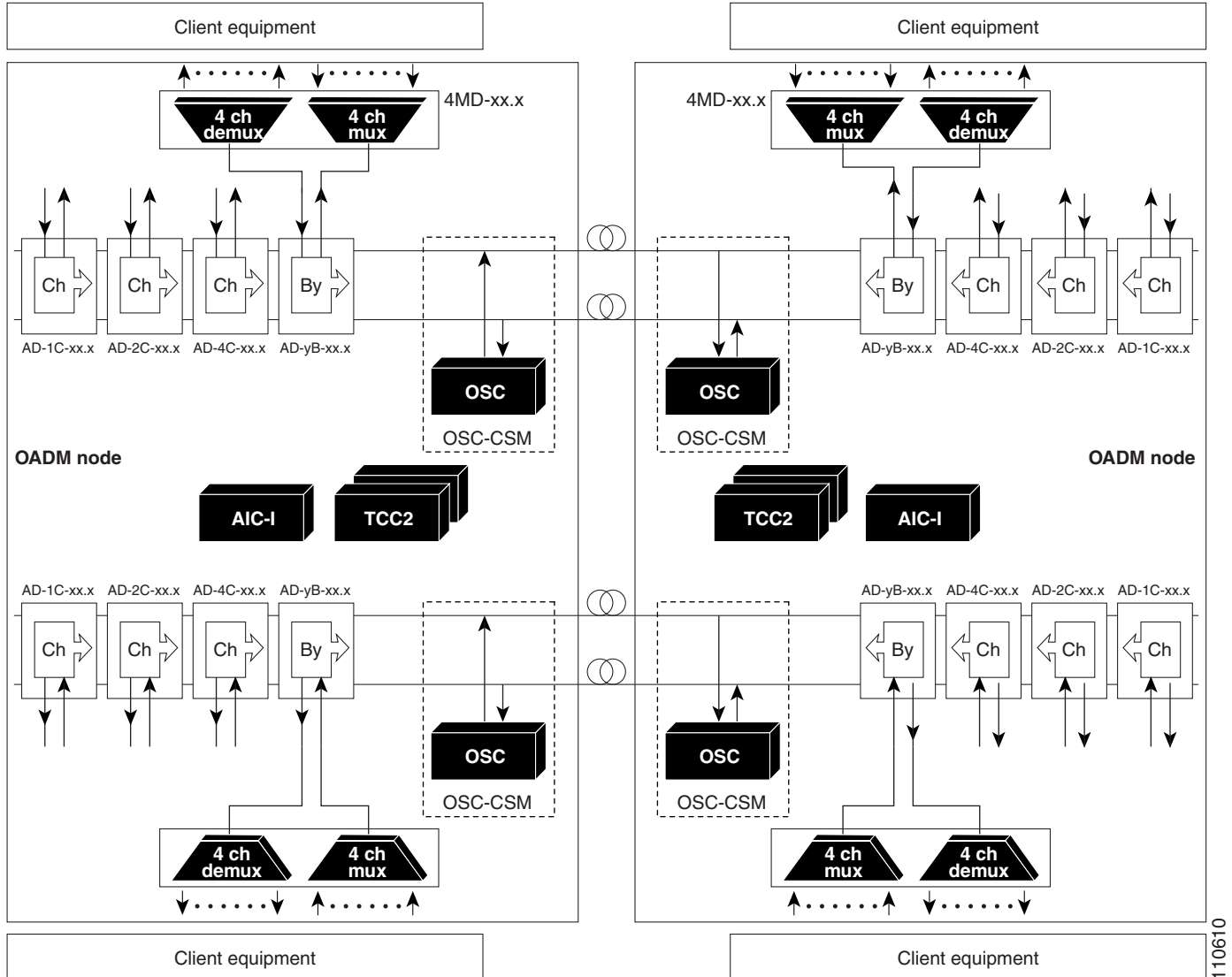

Figure 3-26 shows a 1+1 protected single-span link with passive OADM nodes. This node type can be used in a hybrid configuration.

Figure 3-26 1+1 Protected Single-Span Link with Passive OADM Nodes



110610

3.3.2 Scalable Terminal Node

The scalable terminal node is a single ONS 15454 node equipped with a series of OADM cards and amplifier cards. This node type is more cost effective if a maximum of 16 channels are used (Table 3-1). This node type does not support a terminal configuration exceeding 16 channels because the 32-channel terminal site is more cost effective for 17 channels and beyond.



Note

The dash (—) in the following table below means not applicable.

Table 3-1 Typical Add/Drop Configurations for Scalable Terminal Nodes

Number of Channels	Terminal Configuration	
	Add/Drop Configuration Example 1	Add/Drop Configuration Example 2
1	AD-1C-xx.x	—
2	AD-2C-xx.x	—
3	AD-4C-xx.x	AD-1B-xx.x + 4MD-xx.x
4	AD-4C-xx.x	AD-1B-xx.x + 4MD-xx.x
5	AD-1C-xx.x + AD-4C-xx.x	AD-1C-xx.x + AD-1B-xx.x + 4MD-xx.x
6	AD-2C-xx.x + AD-4C-xx.x	AD-2C-xx.x + AD-1B-xx.x + 4MD-xx.x
7	2 x AD-4C-xx.x	2 x (AD-1B-xx.x + 4MD-xx.x)
8	2 x AD-4C-xx.x	2 x (AD-1B-xx.x + 4MD-xx.x)
9	AD-1C-xx.x + (2 x AD-4C-xx.x)	AD-1C-xx.x + 2 x (AD-1B-xx.x + 4MD-xx.x)
10	AD-2C-xx.x + (2 x AD-4C-xx.x)	AD-2C-xx.x + 2 x (AD-1B-xx.x + 4MD-xx.x)
11	3 x AD-4C-xx.x	AD-4B-xx.x + (3 x 4MD-xx.x)
12	3 x AD-4C-xx.x	AD-4B-xx.x + (3 x 4MD-xx.x)
13	AD-4B-xx.x + (3 x 4MD-xx.x) + AD-1C-xx.x	AD-4B-xx.x + (4 x 4MD-xx.x)
14	AD-4B-xx.x + (3 x 4MD-xx.x) + AD-1C-xx.x	AD-4B-xx.x + (4 x 4MD-xx.x)
15	—	AD-4B-xx.x + (4 x 4MD-xx.x)
16	—	AD-4B-xx.x + (4 x 4MD-xx.x)

The OADM cards that can be used in this type of node are: AD-1C-xx.x, AD-2C-xx.x, AD-4C-xx.x, and AD-1B-xx.x. You can also use AD-4B-xx.x and up to four 4MD-xx.x cards. The OPT-PRE and/or OPT-BST amplifiers can be used. The OPT-PRE or OPT-BST configuration depends on the node loss and the span loss. When the OPT-BST is not installed, the OSC-CSM must be used instead of the OSCM card. [Figure 3-27 on page 3-37](#) shows a channel flow example of a scalable terminal node configuration.

Figure 3-27 Scalable Terminal Channel Flow Example

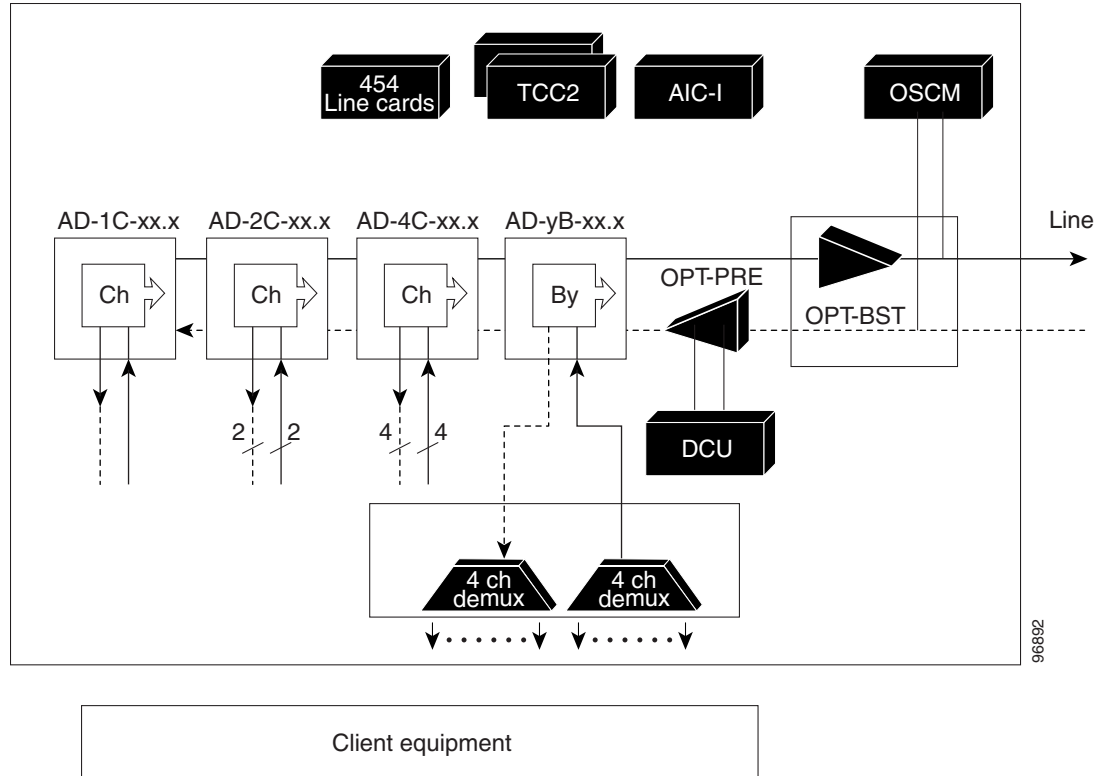

A scalable terminal node can be created by using band and/or channel OADM filter cards. This node type is the most flexible of all node types because the OADM filter cards can be configured to accommodate node traffic. If the node does not contain amplifiers, it is considered a passive hybrid terminal node.

Figure 3-28 shows an example of a scalable terminal node configuration. This node type can be used without add or drop cards.

Figure 3-29 Amplified Hybrid Terminal Example

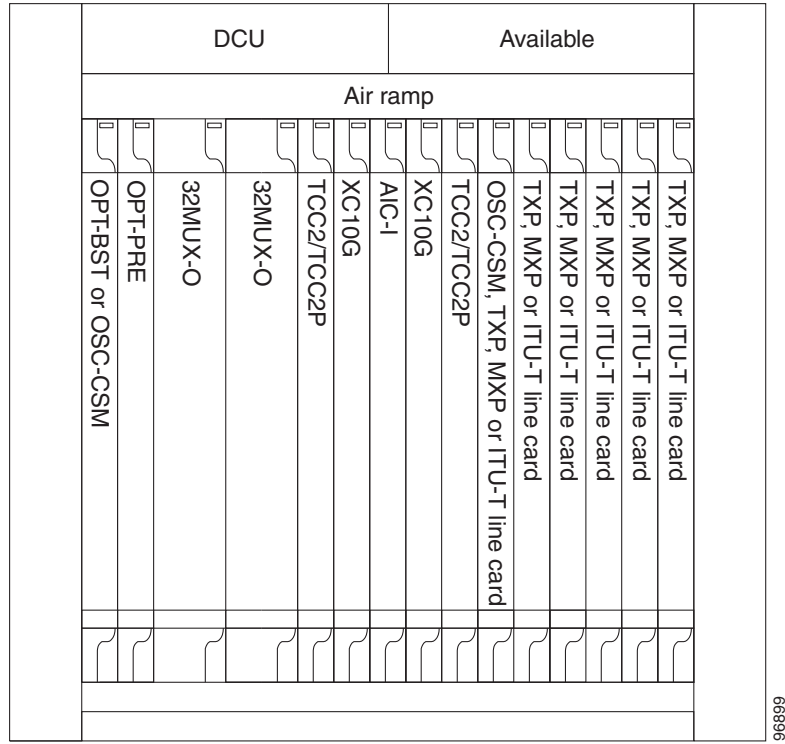
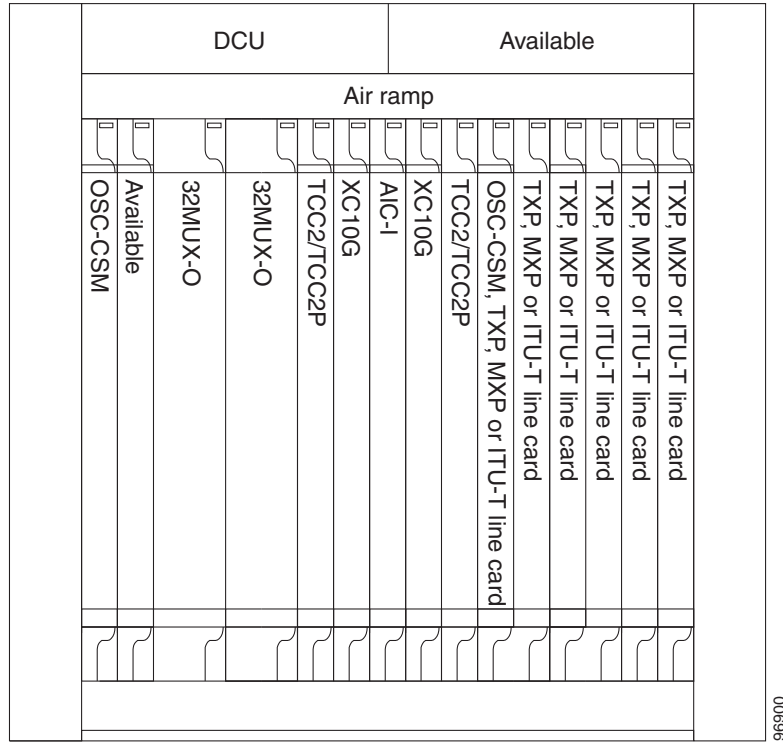

Figure 3-30 shows an example of a passive hybrid terminal node configuration.

Figure 3-30 Passive Hybrid Terminal Example



3.3.4 Hybrid OADM Node

A hybrid OADM node is a single ONS 15454 node equipped with at least one AD-xC-xx.x card or one AD-xB-xx.x card, and two TCC2/TCC2P cards. The hybrid OADM node type is based on the DWDM OADM node type described in the “[OADM Node](#)” section on page 3-4. TDM cards can be installed in any available slot. Review the plan produced by Cisco MetroPlanner to determine slot availability.

[Figure 3-31](#) shows an example of an amplified hybrid OADM node configuration. The hybrid OADM node can also become passive by removing the amplifier cards.

Figure 3-31 Hybrid Amplified OADM Example

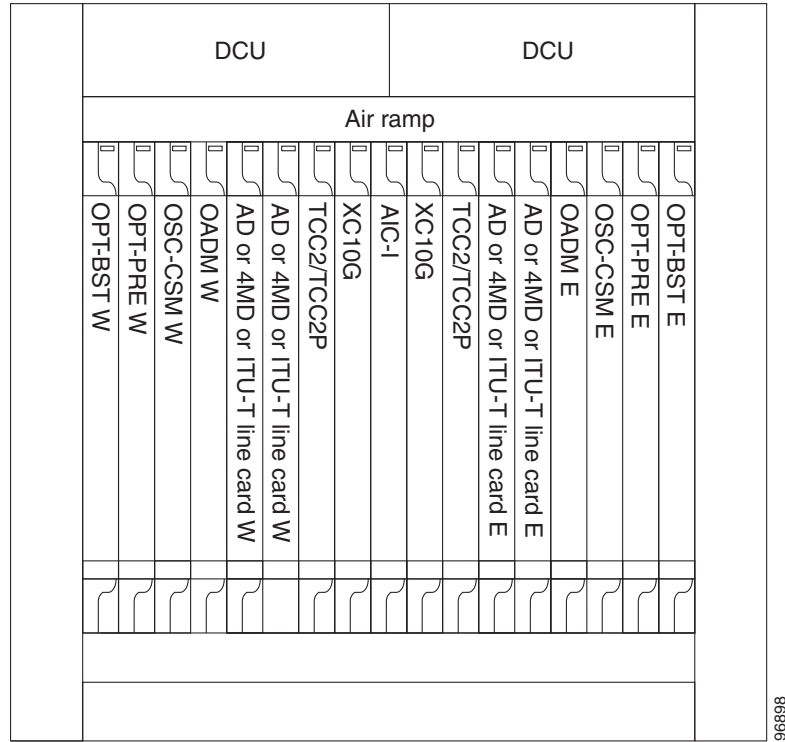

3.3.5 Hybrid Line Amplifier Node

A hybrid line amplifier node is a single ONS 15454 node with open slots for both TDM and DWDM cards. [Figure 3-32](#) shows an example of a hybrid line amplifier node configuration. [Figure 3-33 on page 3-43](#) shows a channel flow example of a hybrid line node configuration. Since this node contains both TDM and DWDM rings, both TDM and DWDM rings should be terminated even if no interactions are present between them.



Note

For DWDM applications, if the OPT-BST card is not installed within the node, the OSC-CSM card must be used instead of the OSCM card.

Figure 3-32 Hybrid Line Amplifier Example

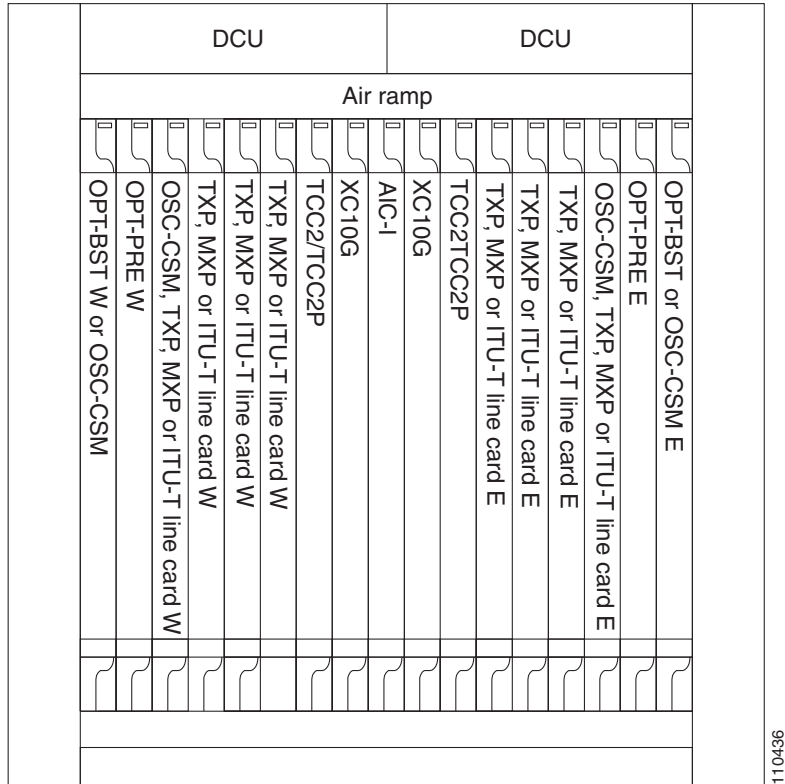
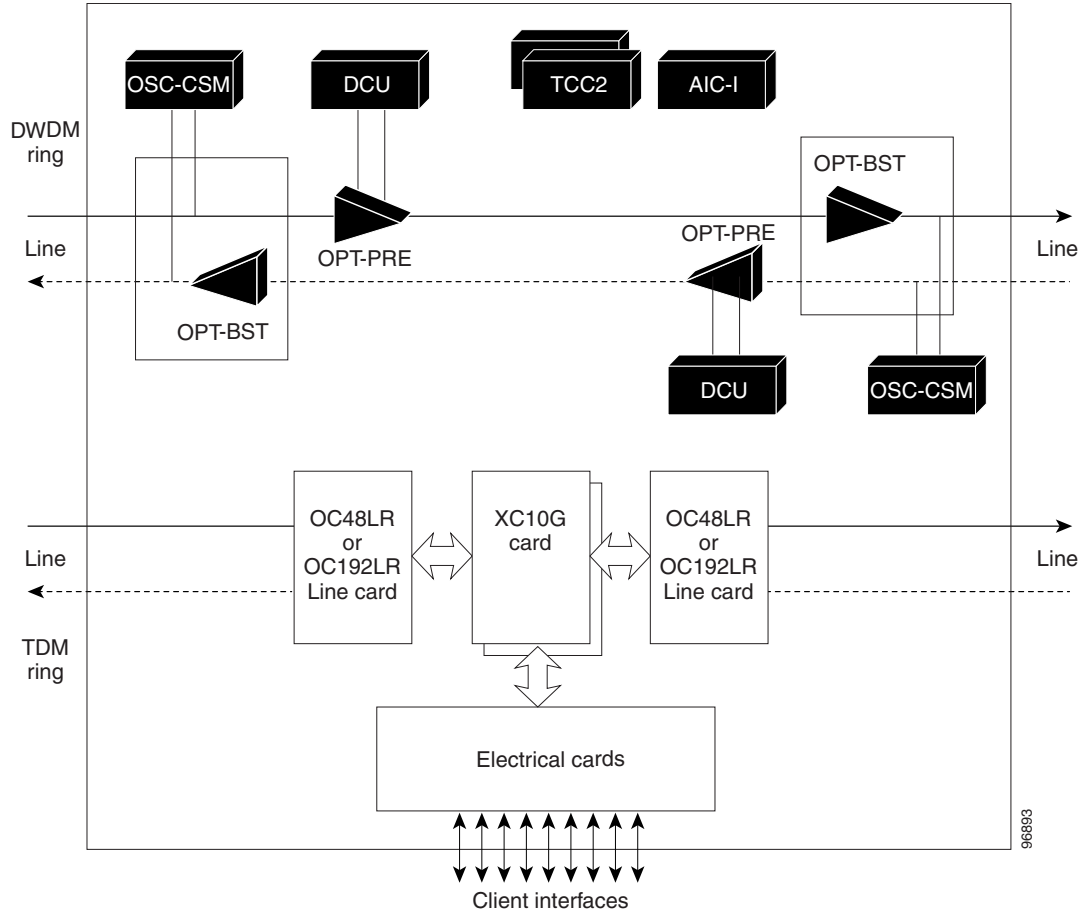

Figure 3-33 Hybrid Line Amplifier Channel Flow Example



A hybrid line node is another example of the hybrid line amplifier OADM node. A hybrid line node is single ONS 15454 node equipped with OPT-PRE amplifiers, OPT-BST amplifiers, and TCC2/TCC2P cards for each line direction. Both types of amplifiers can be used or just one type of amplifier. Attenuators might also be required between each preamplifier and booster amplifier to match the optical input power value and to maintain the amplifier gain tilt value. TDM cards can be installed in any available slot. Review the plan produced by Cisco MetroPlanner to determine slot availability.

3.3.6 Amplified TDM Node

An amplified TDM node is a single ONS 15454 node that increases the span length between two ONS 15454 nodes that contain TDM cards and optical amplifiers. There are three possible installation configurations for an amplified TDM node. Scenario 1 uses client cards and OPT-BST amplifiers. Scenario 2 uses client cards, OPT-BST amplifiers, OPT-PRE amplifiers, and FlexLayer filters. Scenario 3 uses client cards, OPT-BST amplifiers, OPT-PRE amplifiers, AD-1C-xx.x cards, and OSC-CSM cards.

The client cards that can be used in an amplified TDM node are: TXP_MR_10G, MXP_2.5G_10G, TXP_MR_2.5G, TXPP_MR_2.5G, OC-192 LR/STM 64 ITU 15xx.xx, and OC-48 ELR/STM 16 EH 100 GHz.

Figure 3-34 shows the first amplified TDM node scenario with an OPT-BST amplifier.

Figure 3-34 Amplified TDM Example with an OPT-BST Amplifier

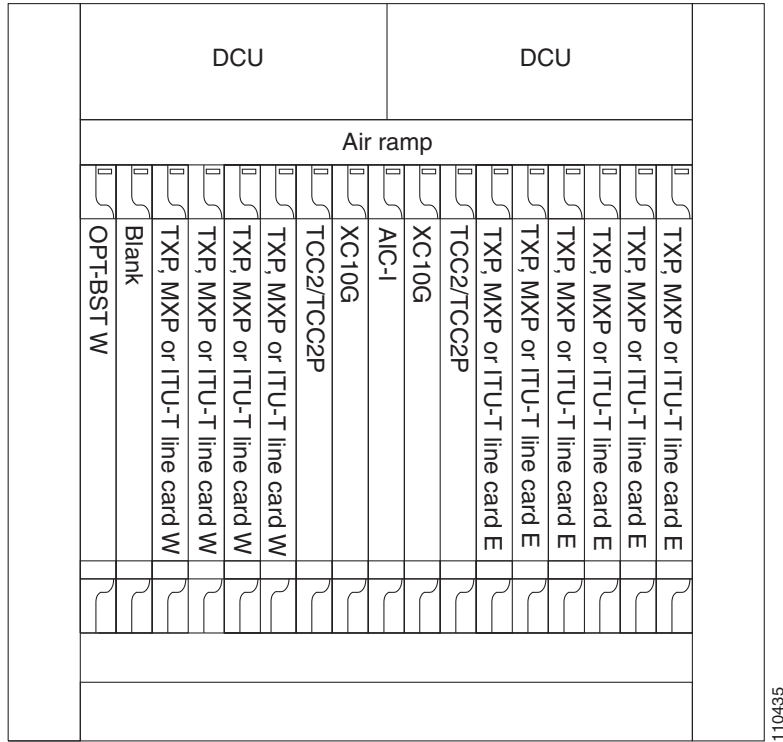

Figure 3-35 shows the first amplified TDM node channel flow scenario configured with OPT-BST amplifiers.

Figure 3-35 Amplified TDM Channel Flow Example With OPT-BST Amplifiers

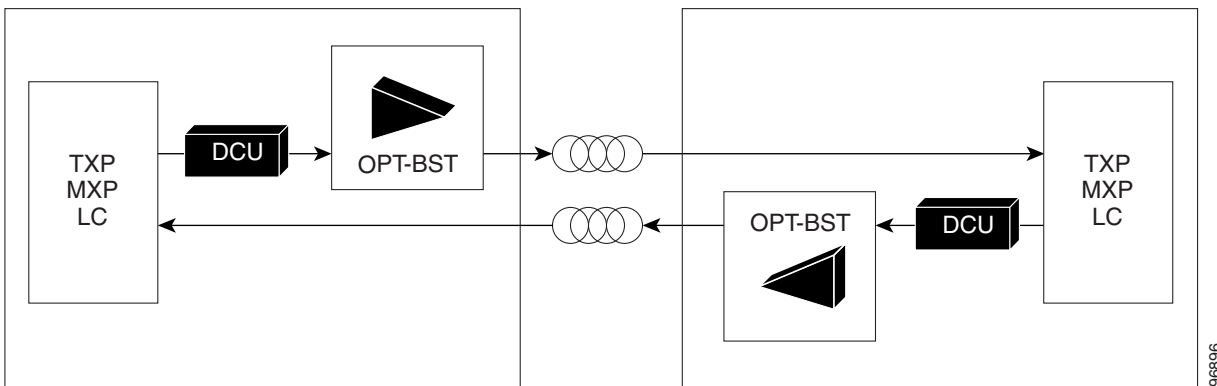

Figure 3-36 shows the second amplified TDM node configuration scenario with client cards, AD-1C-xx.x cards, OPT-BST amplifiers, OPT-PRE amplifiers, and FlexLayer filters.

Figure 3-36 Amplified TDM Example with FlexLayer Filters

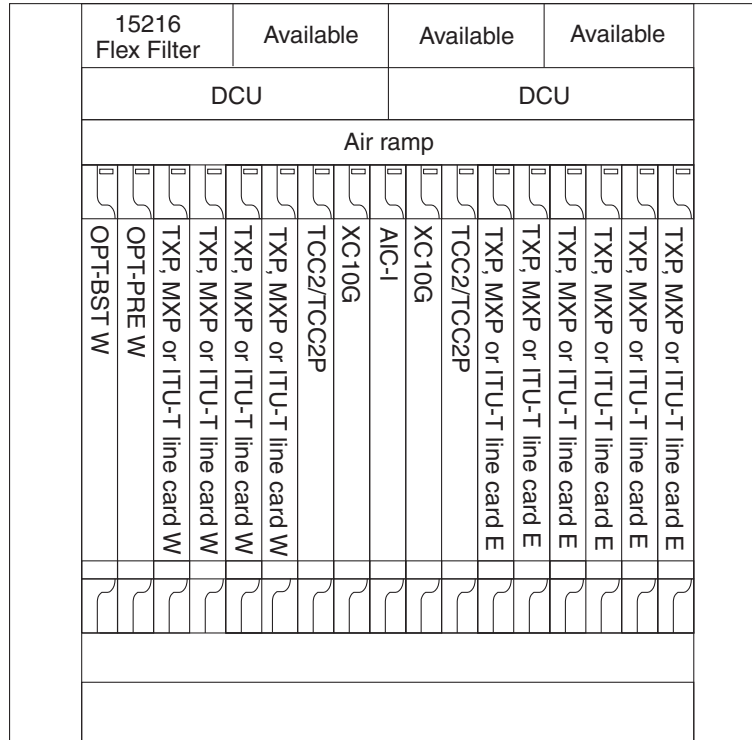

Figure 3-37 shows the second amplified TDM node channel flow configuration scenario with client cards, OPT-BST amplifiers, OPT-PRE amplifiers, and FlexLayer filters.

Figure 3-37 Amplified TDM Channel Flow Example With FlexLayer Filters

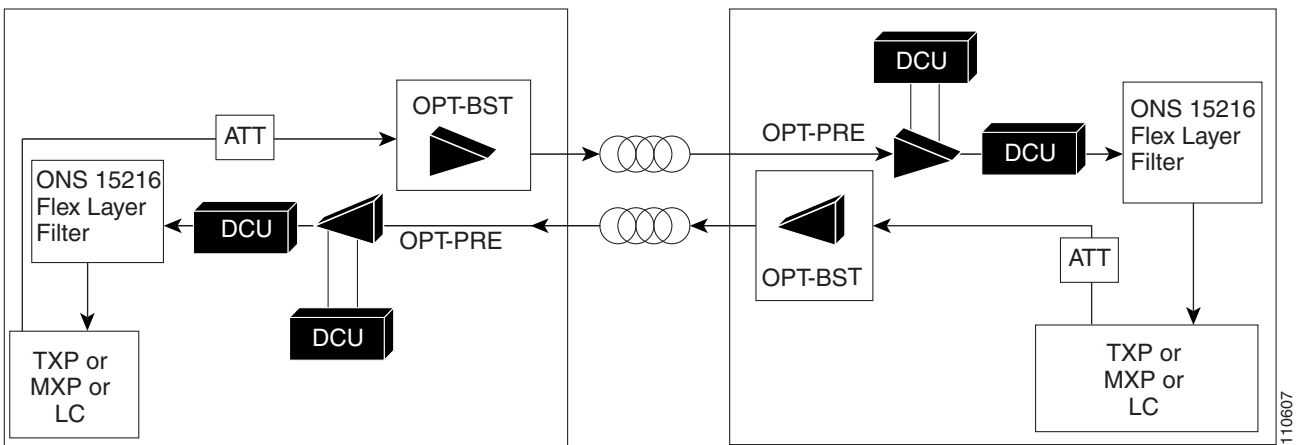
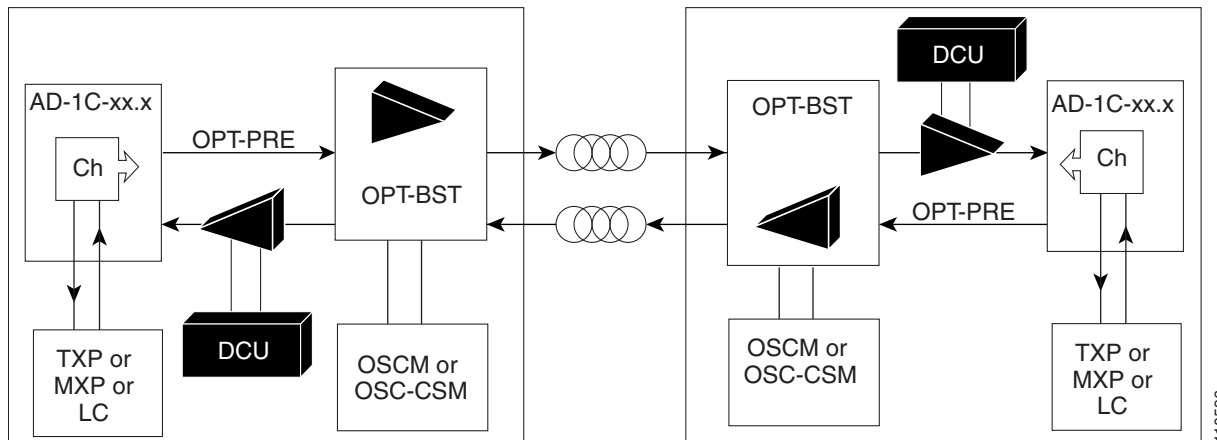

Figure 3-38 shows the third amplified TDM channel flow configuration scenario with client cards, OPT-BST amplifiers, OPT-PRE amplifiers, AD-1C-xx.x cards, and OSC-CSM cards.

Figure 3-38 Amplified TDM Channel Flow Example With Amplifiers, AD-1C-xx.x Cards, and OSC-CSM Cards



3.4 Automatic Node Setup

Automatic node setup (ANS) is a TCC2/TCC2P function that adjusts values of the variable optical attenuators (VOAs) on the DWDM channel paths to equalize the per-channel power at the amplifier input. This power equalization means that at launch, all the channels have the same amplifier power level, independent from the input signal on the client interface and independent from the path crossed by the signal inside the node. This equalization is needed for two reasons:

- Every path introduces a different penalty on the signal that crosses it.
- Client interfaces add their signal to the ONS 15454 DWDM ring with different power levels.

To support ANS, the integrated VOAs and photodiodes are provided in the following ONS 15454 DWDM cards:

- AD-xB-xx.x card express and drop paths
- AD-xC-xx.x card express and add paths
- 4MD-xx.x card input ports
- 32MUX-O card input ports
- 32WSS card input ports
- 32DMX-O and 32DMX card output ports

Optical power is equalized by regulating the VOAs. Based on the expected per-channel power, ANS automatically calculates the VOA values by:

- Reconstructing the different channels paths
- Retrieving the path insertion loss (stored in each DWDM transmission element)

VOAs operate in one of three working modes:

- Automatic VOA Shutdown—In this mode, the VOA is set at maximum attenuation value. Automatic VOA shutdown mode is set when the channel is not provisioned to ensure system reliability in the event that power is accidentally inserted.

- **Constant Attenuation Value**—In this mode, the VOA is regulated to a constant attenuation independent from the value of the input signal. Constant attenuation value mode is set on the following VOAs:
 - OADM band card VOAs on express and drop paths (as operating mode)
 - OADM channel card VOAs during power insertion startup
 - Multiplexer/Demultiplexer card VOAs during power insertion startup
- **Constant Power Value**—In this mode, the VOA values are automatically regulated to keep a constant output power when changes occur to the input power signal. This working condition is set on OADM channel card VOAs as “operating” and on 32MUX-O, 32WSS, 32DMX-O, and 32DMX card VOAs as “operating mode.”

In the normal operating mode, OADM band card VOAs are set to a constant attenuation, while OADM channel card VOAs are set to a constant power. ANS requires the following VOA provisioning parameters to be specified:

- Target attenuation (OADM band card VOA and OADM channel card startup)
- Target power (channel VOA)

To allow you to modify ANS values based on your DWDM deployment, provisioning parameters are divided into two contributions:

- Reference Contribution— (Display only) Set by ANS.
- Calibration Contribution—Set by user.

The ANS equalization algorithm requires the following knowledge of the DWDM transmission element layout:

- The order in which the DWDM elements are connected together on the express paths
- Channels that are dropped and added
- Channels or bands that have been configured as pass-through

ANS assumes that every DWDM port has a line direction parameter that is either west to east (W-E) or east to west (E-W). ANS automatically configures the mandatory optical connections according to following main rules:

- Cards equipped in Slots 1 to 6 have a drop section facing west.
- Cards equipped in Slots 12 to 17 have a drop section facing east.
- Contiguous cards are cascaded on the express path.
- 4MD-xx.x and AD-xB-xx.x are always optically coupled.
- A 4MD-xx.x absence forces an optical pass-through connection.
- Transmit (Tx) ports are always connected to receive (Rx) ports.

Optical patchcords are passive devices that are not autodiscovered by ANS. However, optical patchcords are used to build the alarm correlation graph. From CTC or TL1 you can:

- Calculate the default connections on the NE.
- Retrieve the list of existing connections.
- Retrieve the list of free ports.
- Create new connections or modify existing ones.
- Launch ANS.

After you launch ANS, the following status are provided for each ANS parameter:

- Success - Changed—The parameter setpoint was recalculated successfully.
- Success - Unchanged—The parameter setpoint did not need recalculation.
- Not Applicable—The parameter setpoint does not apply to this node type.
- Fail - Out of Range—The calculated setpoint is outside the expected range.
- Fail - Port in IS State—The parameter could not be calculated because the port is in service.

Optical connections are identified by the two termination points, each with an assigned slot and port. ANS checks that a new connection is feasible (according to embedded connection rules) and returns a denied message in the case of a violation.

ANS requires provisioning of the expected wavelength. When provisioning the expected wavelength, the following rules apply:

- The card name is generically characterized by the card family, and not the particular wavelengths supported (for example, AD-2C for all 2-channel OADMs).
- At the provisioning layer, you can provision a generic card for a specific slot using CTC or TL1.
- Wavelength assignment is done at the port level.
- An equipment mismatch alarm is raised when a mismatch between the identified and provisioned value occurs. The default value for the provisioned attribute is AUTO.

3.4.1 Automatic Node Setup Parameters

All ONS 15454 ANS parameters are calculated by Cisco MetroPlanner for nodes configured for metro core networks. (Parameters must be configured manually for metro access nodes.) Cisco MetroPlanner exports the calculated parameters to an ASCII file called “NE Update.” In CTC, you can import the NE Update file to automatically provision the node. [Table 3-2](#) shows ANS parameters arranged in east and west, transmit and receive groups.

Table 3-2 ANS Parameters

Direction	ANS Parameters
West Side - Receive	<ul style="list-style-type: none"> • West Side Rx Max Expected Span Loss • West Side Rx Min Expected Span Loss • West Side Rx Amplifier Working Mode • West Side Rx Amplifier Ch Power • West Side Rx Amplifier Gain • West Side Rx Amplifier Tilt • West Side OSC LOS Threshold • West Side Channel LOS Threshold • West Side Rx Amplifier Input Power Fail Th • West Side Add and Drop Stage Input Power • West Side Add and Drop Stage Drop Power • West Side Add and Drop Stage Band (<i>n</i>) Drop Power (<i>n</i> = 1 to 8) • West Side Add and Drop Stage Channel (<i>n</i>) Drop Power (<i>n</i> = 1 to 32)
East Side - Receive	<ul style="list-style-type: none"> • East Side Rx Max Expected Span Loss • East Side Rx Min Expected Span Loss • East Side Rx Amplifier Working Mode • East Side Rx Amplifier Ch Power • East Side Rx Amplifier Gain • East Side Rx Amplifier Tilt • East Side OSC LOS Threshold • East Side Channel LOS Threshold • East Side Rx Amplifier Input Power Fail Th • East Side Add and Drop Stage Input Power • East Side Add and Drop Stage Drop Power • East Side Add and Drop Stage Band (<i>n</i>) Drop Power (<i>n</i> = 1 to 8) • East Side Add and Drop Stage Channel (<i>n</i>) Drop Power (<i>n</i> = 1 to 32)

Table 3-2 ANS Parameters (continued)

Direction	ANS Parameters
West Side - Transmit	<ul style="list-style-type: none"> • West Side Tx Amplifier Working Mode • West Side Tx Amplifier Ch Power • West Side Tx Amplifier Gain • West Side Tx Amplifier Tilt • West Side Fiber Stage Input Threshold • West Side Add and Drop Stage Output Power • West Side Add and Drop Stage By-Pass Power
East Side - Transmit	<ul style="list-style-type: none"> • East Side Tx Amplifier Working Mode • East Side Tx Amplifier Ch Power • East Side Tx Amplifier Gain • East Side Tx Amplifier Tilt • East Side Fiber Stage Input Threshold • East Side Add and Drop Stage Output Power • East Side Add and Drop Stage By-Pass Power

3.4.2 View and Provision ANS Parameters

All ANS parameters can be viewed and provisioned from the node view Provisioning > WDM-ANS > Provisioning tabs, shown in [Figure 3-39 on page 3-51](#). The WDM-ANS > Provisioning > Provisioning tabs presents the parameters in the following tree view:

```

root
+/- East
  +/- Receiving
    +/- Amplifier
    +/- Power
    +/- Threshold
  +/- Transmitting
    +/- Amplifier
    +/- Power
    +/- Threshold
+/- West
  +/- Receiving
    +/- Amplifier
    +/- Power
    +/- Threshold
  +/- Transmitting

```

- +/- Amplifier
- +/- Power
- +/- Threshold

Figure 3-39 WDM-ANS Provisioning

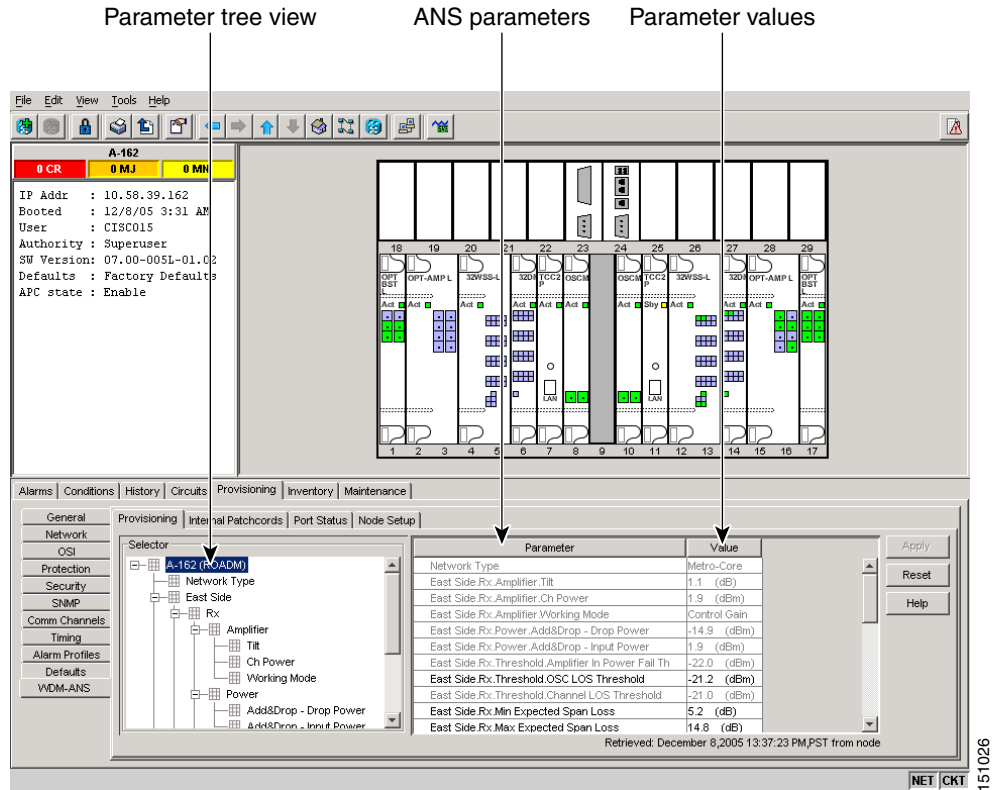

Table 3-3 shows the parameter IDs based on platform, line direction, and functional group.

Table 3-3 ANS-WDM > Provisioning Subtab Parameters

Tree Element	Parameters
root	Network Type (dwdm)
root +/- East +/- Receiving	East Side Rx Max Expected Span Loss East Side Rx Min Expected Span Loss
root +/- East +/- Receiving +/- Amplifier	East Side Rx Amplifier Working Mode East Side Rx Amplifier Ch Power East Side Rx Amplifier Gain East Side Rx Amplifier Tilt

Table 3-3 ANS-WDM > Provisioning Subtab Parameters (continued)

Tree Element	Parameters
root +/- East +/- Receiving +/- Power	East Side Add&Drop - Input Power East Side Add&Drop - Drop Power East Side Band n Drop Power ($n = 1-8$) East Side Channel n Drop Power East ($n = 1-32$)
root +/- East +/- Receiving +/- Thresholds	East Side OSC LOS Threshold East Side Channel LOS Threshold East Side Rx Amplifier In Power Fail Th
root +/- East +/- Transmitting +/- Amplifier	East Side Tx Amplifier Working Mode East Side Tx Amplifier Ch Power East Side Tx Amplifier Gain East Side Tx Amplifier Tilt
root +/- East +/- Transmitting +/- Power	East Side Add&Drop - Output Power East Side Add&Drop - By-Pass Power
root +/- East +/- Transmitting +/- Thresholds	East Side Fiber Stage Input Threshold
root +/- West +/- Receiving	West Side Rx Max Expected Span Loss West Side Rx Min Expected Span Loss
root +/- West +/- Receiving +/- Amplifier	West Side Rx Amplifier Working Mode West Side Rx Amplifier Ch Power West Side Rx Amplifier Gain West Side Rx Amplifier Tilt
root +/- West +/- Receiving +/- Power	West Side Add&Drop - Input Power West Side Add&Drop - Drop Power West Side Band n Drop Power ($n = 1-8$) West Side Channel n Drop Power ($n = 1-32$)
root +/- West +/- Receiving +/- Thresholds	West Side OSC LOS Threshold West Side Channel LOS Threshold West Side Rx Amplifier In Power Fail Th
root +/- West +/- Transmitting +/- Amplifier	West Side Tx Amplifier Working Mode West Side Tx Amplifier Ch Power West Side Tx Amplifier Gain West Side Tx Amplifier Tilt
root +/- East +/- Transmitting +/- Power	West Side Add&Drop - Output Power West Side Add&Drop - By-Pass Power
root +/- West +/- Transmitting +/- Thresholds	West Side Fiber Stage Input Threshold

The ANS parameters that appear in the WDM-ANS > Provisioning tabs depend on the node type. Table 3-4 shows the DWDM node types and their ANS parameters.

Table 3-4 ANS Parameters By Node Type

Node Type	Parameter Group	Parameters
Hub	Network	Network Type
	Span Loss	East and West Expected Span Loss
	Amplifier Tx	East and West Side Transmit Amplifier Working Mode East and West Side Transmit Amplifier Channel Power East and West Side Transmit Amplifier Gain East and West Side Transmit Amplifier Tilt
	Amplifier Rx	East and West Side Receive Amplifier Working Mode East and West Side Receive Amplifier Channel Power East and West Side Receive Amplifier Gain East and West Side Receive Amplifier Tilt
	Thresholds Tx	East and West Side Fiber Stage Input Threshold
	Thresholds Rx	East and West Side Osc Los Threshold East and West Side Channel Los Threshold East and West Side Receive Amplifier Input Power Fail
	Power	East and West Side Add&Drop - Input Power East and West Side Add&Drop - Output Power East and West Side Add&Drop - By-Pass Power East and West Side Channel (n) Drop Power where $n = 1-32$

Table 3-4 ANS Parameters By Node Type (continued)

Node Type	Parameter Group	Parameters
Terminal	Network	Network Type
	Span Loss	East or West Expected Span Loss
	Amplifier Tx	East or West Side Transmit Amplifier Working Mode East or West Side Transmit Amplifier Channel Power East or West Side Transmit Amplifier Gain East or West Side Transmit Amplifier Tilt
	Amplifier Rx	East or West Side Receive Amplifier Working Mode East or West Side Receive Amplifier Channel Power East or West Side Receive Amplifier Gain East or West Side Receive Amplifier Tilt
	Thresholds Tx	East or West Side Fiber Stage Input Threshold
	Thresholds Rx	East or West Side Osc Los Threshold East or West Side Channel Los Threshold East or West Side Receive Amplifier Input Power Fail
	Power	East or West Side Add&Drop - Input Power East or West Side Add&Drop - Output Power East or West Side Channel (n) Drop Power ($n = 1-32$)
Flexible Channel Count Terminal	Network	Network Type
	Span Loss	East and West Expected Span Loss
	Amplifier Tx	East and West Side Transmit Amplifier Working Mode East and West Side Transmit Amplifier Channel Power East and West Side Transmit Amplifier Gain East and West Side Transmit Amplifier Tilt
	Amplifier Rx	East and West Side Receive Amplifier Working Mode East and West Side Receive Amplifier Channel Power East and West Side Receive Amplifier Gain East and West Side Receive Amplifier Tilt
	Thresholds Tx	East and West Side Fiber Stage Input Threshold
	Thresholds Rx	East and West Side Osc Los Threshold East and West Side Channel Los Threshold East and West Side Receive Amplifier Input Power Fail
	Power	East and West Side Add&Drop - Input Power East and West Side Add&Drop - Output Power East and West Side Band (n) Drop Power ($n = 1-8$)

Table 3-4 ANS Parameters By Node Type (continued)

Node Type	Parameter Group	Parameters
OADM	Network	Network Type
	Span Loss	East and West Expected Span Loss
	Amplifier Tx	East and West Side Transmit Amplifier Working Mode East and West Side Transmit Amplifier Channel Power East and West Side Transmit Amplifier Gain East and West Side Transmit Amplifier Tilt
	Amplifier Rx	East and West Side Receive Amplifier Working Mode East and West Side Receive Amplifier Channel Power East and West Side Receive Amplifier Gain East and West Side Receive Amplifier Tilt
	Thresholds Tx	East and West Side Fiber Stage Input Threshold
	Thresholds Rx	East and West Side Osc Los Threshold East and West Side Channel Los Threshold East and West Side Receive Amplifier Input Power Fail
	Power	East and West Side Add&Drop - Input Power East and West Side Add&Drop - Output Power East and West Side Band (<i>n</i>) Drop Power (<i>n</i> = 1–8)
Line Amplifier	Network	Network Type
	Span Loss	East and West Expected Span Loss
	Amplifier Tx	East and West Side Transmit Amplifier Working Mode East and West Side Transmit Amplifier Channel Power East and West Side Transmit Amplifier Gain East and West Side Transmit Amplifier Tilt
	Amplifier Rx	East and West Side Receive Amplifier Working Mode East and West Side Receive Amplifier Channel Power East and West Side Receive Amplifier Gain East and West Side Receive Amplifier Tilt
	Thresholds Tx	East and West Side Fiber Stage Input Threshold
	Thresholds Rx	East and West Side Osc Los Threshold East and West Side Channel Los Threshold East and West Side Receive Amplifier Input Power Fail

Table 3-4 ANS Parameters By Node Type (continued)

Node Type	Parameter Group	Parameters
ROADM	Network	Network Type
	Span Loss	East and West Expected Span Loss
	Amplifier Tx	East and West Side Transmit Amplifier Working Mode East and West Side Transmit Amplifier Channel Power East and West Side Transmit Amplifier Gain East and West Side Transmit Amplifier Tilt
	Amplifier Rx	East and West Side Receive Amplifier Working Mode East and West Side Receive Amplifier Channel Power East and West Side Receive Amplifier Gain East and West Side Receive Amplifier Tilt
	Thresholds Tx	East and West Side Fiber Stage Input Threshold
	Thresholds Rx	East and West Side Osc Los Threshold East and West Side Channel Los Threshold East and West Side Receive Amplifier Input Power Fail
	Power	East and West Side Add&Drop - Input Power (if a 32DMX east/west card is installed) East and West Side Add&Drop - Output Power East and West Side Add&Drop - Drop Power (if a 32DMX east/west card is installed) East and West Side Channel (n) Drop Power (if a 32DMX-O east/west card is installed) ($n = 1-32$)

Table 3-5 shows the following information for all ONS 15454 ANS parameters:

- Min—Minimum value in decibels.
- Max—Maximum value in decibels.
- Def—Default value in decibels. Other defaults include MC (metro core), CG (control gain), U (unknown).
- Group—Group(s) to which the parameter belongs: ES (east side), WS (west side), Rx (receive), Tx (transmit), Amp (amplifier), P (power), DB (drop band), DC (drop channel), A (attenuation), Th (threshold).
- Network Type—Parameter network type: MC (metro core), MA (metro access), ND (not DWDM)
- Optical Type—Parameter optical type: TS (32 channel terminal), FC (flexible channel count terminal), O (OADM), H (hub), LS (line amplifier), R (ROADM), U (unknown)

Table 3-5 ANS Parameters Summary

General Name	Min	Max	Def	Group	Network Type	Optical Type
Network Type	—	—	MC	Root	MC, MA, ND	U, TS, FC, O, H, LS, R
West Side Rx Max Expected Span Loss	0	60	60	WS, Rx	MC, MA	TS, FC, O, H, LS, R

Table 3-5 ANS Parameters Summary (continued)

General Name	Min	Max	Def	Group	Network Type	Optical Type
East Side Rx Max Expected Span Loss	0	60	60	ES, Rx	MC, MA	TS, FC, O, H, LS, R
West Side Rx Min Expected Span Loss	0	60	60	WS, Rx	MC, MA	TS, FC, O, H, LS, R
East Side Rx Min Expected Span Loss	0	60	60	ES, Rx	MC, MA	TS, FC, O, H, LS, R
West Side Tx Amplifier Working Mode	—	—	CG	WS, Tx, Amp	MC, MA, ND	TS, FC, O, H, LS, R
East Side Tx Amplifier Working Mode	—	—	CG	ES, Rx	MC, MA	TS, FC, O, H, LS, R
West Side Rx Amplifier Working Mode	—	—	CG	WS, Tx, Amp	MC, MA, ND	TS, FC, O, H, LS, R
East Side Rx Amplifier Working Mode	—	—	CG	ES, Rx	MC, MA	TS, FC, O, H, LS, R
West Side Tx Amplifier Ch Power	-10	17	2	WS, Tx, Amp	MC, MA, ND	TS, FC, O, H, LS, R
East Side Tx Amplifier Ch Power	-10	17	2	WS, Tx, Amp	MC, MA, ND	TS, FC, O, H, LS, R
West Side Rx Amplifier Ch Power	-10	17	2	WS, Tx, Amp	MC, MA, ND	TS, FC, O, H, LS, R
East Side Rx Amplifier Ch Power	-10	17	2	WS, Tx, Amp	MC, MA, ND	TS, FC, O, H, LS, R
West Side Tx Amplifier Gain	0	30	0	WS, Tx, Amp	MA	TS, FC, O, H, LS, R
East Side Tx Amplifier Gain	0	30	0	WS, Tx, Amp	MA	TS, FC, O, H, LS, R
West Side Rx Amplifier Gain	0	30	0	WS, Tx, Amp	MA	TS, FC, O, H, LS, R
East Side Rx Amplifier Gain	0	30	0	WS, Tx, Amp	MA	TS, FC, O, H, LS, R
West Side Tx Amplifier Tilt	0	30	0	WS, Tx, Amp	MC, MA	TS, FC, O, H, LS, R
East Side Tx Amplifier Tilt	0	30	0	WS, Tx, Amp	MC, MA	TS, FC, O, H, LS, R
West Side Rx Amplifier Tilt	0	30	0	WS, Rx, Amp	MC, MA	TS, FC, O, H, LS, R
East Side Rx Amplifier Tilt	0	30	0	WS, Rx, Amp	MC, MA	TS, FC, O, H, LS, R
West Side OSC LOS Threshold	-50	30	U	WS, Rx, Th	MC, MA	TS, FC, O, H, LS, R
East Side OSC LOS Threshold	-50	30	U	WS, Rx, Th	MC, MA	TS, FC, O, H, LS, R
West Side Channel LOS Threshold	-50	30	U	WS, Rx, Th	MC, MA	TS, FC, O, H, LS, R
East Side Channel LOS Threshold	-50	30	U	ES, Rx, Th	MC, MA, ND	TS, FC, O, H, LS, R
West Side Fiber State Input Threshold	-50	30	U	WS, Tx, Th	MC, MA, ND	TS, FC, O, H, LS, R
East Side Fiber State Input Threshold	-50	30	U	ES, Tx, Th	MC, MA, ND	TS, FC, O, H, LS, R
West Side Add&Drop - Output Power	-50	30	-14	WS, Tx, P	MC	TS, FC, O, H, R
East Side Add&Drop - Output Power	-50	30	-14	ES, Tx, P	MC	TS, FC, O, H, R
West Side Add&Drop - Input Power	-50	30	-14	WS, Rx, P	MC	TS, FC, O, H, R
East Side Add&Drop - Input Power	-50	30	-14	ES, Rx, P	MC	TS, FC, O, H, R
West Side Add&Drop - By-Pass Power	-50	30	-14	WS, Tx, P	MC	H
East Side Add&Drop - By-Pass Power	-50	30	-14	ES, Tx, P	MC	H
West Side Add&Drop - Drop Power	-50	30	-14	WS, Tx, P	MC	R
East Side Add&Drop - Drop Power	-50	30	-14	ES, Tx, P	MC	R
West Side Band 1...8 Drop Power	-50	30	-14	WS, Rx, P, DB	MC	FC, O
East Side Band 1...8 Drop Power	-50	30	-14	ES, Rx, P, DB	MC	FC, O

Table 3-5 ANS Parameters Summary (continued)

General Name	Min	Max	Def	Group	Network Type	Optical Type
West Side Channel 1...32 Drop Power	-50	30	-14	WS, Rx, P, DC, B1	MC, MA	TS, H, R
East Side Channel 1...32 Drop Power	-50	30	-14	ES, Rx, P, DC, B1	MC, MA	TS, H, R