



Optical Cards

This chapter describes the Cisco ONS 15454 optical card features and functions. It includes descriptions, hardware specifications, and block diagrams for each optical card. For installation and card turn-up procedures, refer to the *Cisco ONS 15454 Procedure Guide*.



Note

The terms "Unidirectional Path Switched Ring" and "UPSR" may appear in Cisco literature. These terms do not refer to using Cisco ONS 15xxx products in a unidirectional path switched ring configuration. Rather, these terms, as well as "Path Protected Mesh Network" and "PPMN," refer generally to Cisco's path protection feature, which may be used in any topological network configuration. Cisco does not recommend using its path protection feature in any particular topological network configuration.

Chapter topics include:

- [4.1 OC-N Cards, page 4-1](#)
- [4.2 Transponder and Muxponder Cards, page 4-58](#)

4.1 OC-N Cards

This section gives an overview and detailed descriptions of the Cisco ONS 14454 OC-N cards

4.1.1 OC-N Card Overview



Warning

Class 1 (21 CFR 1040.10 and 1040.11) and Class 1M (IEC 60825-1 2001-01) laser products. Invisible laser radiation may be emitted from the end of the unterminated fiber cable or connector. Do not stare into the beam or view directly with optical instruments. Viewing the laser output with certain optical instruments (for example, eye loupes, magnifiers, and microscopes) within a distance of 100 mm may pose an eye hazard. Use of controls or adjustments, or performance of procedures other than those specified may result in hazardous radiation exposure. Invisible laser radiation present.



Warning

Use of controls, adjustments, or performing procedures other than those specified may result in hazardous radiation exposure.

For software and cross-connect card compatibility information, see the [“2.1.2 Card Compatibility” section on page 2-2](#).

Each card is marked with a symbol that corresponds to a slot (or slots) on the ONS 15454 shelf assembly. The cards are then installed into slots displaying the same symbols. See the [“1.13 Cards and Slots” section on page 1-42](#) for a list of slots and symbols.

[Table 4-1](#) lists the Cisco ONS 15454 OC-N cards.

Table 4-1 OC-N Cards for the ONS 15454

Card	Port Description	For Additional Information...
OC3 IR 4 SH 1310	The OC3 IR 4 SH 1310 card provides four intermediate- or short-range OC-3 ports and operates at 1310 nm. Note The OC3 IR 4 SH 1310 and OC3 IR 4/STM1 SH 1310 cards are functionally the same.	See the “4.1.2 OC3 IR 4/STM1 SH 1310 Card” section on page 4-4 .
OC3 IR 4/ STM1 SH 1310	The OC3 IR 4/STM1 SH 1310 card provides four intermediate- or short-range OC-3 ports and operates at 1310 nm.	See the “4.1.2 OC3 IR 4/STM1 SH 1310 Card” section on page 4-4 .
OC3 IR/ STM1 SH 1310-8	The OC3 IR/STM1 SH 1310-8 card provides eight intermediate- or short-range OC-3 ports and operates at 1310 nm.	See the “4.1.3 OC3 IR/STM1 SH 1310-8 Card” section on page 4-7 .
OC12 IR 1310	The OC12 IR 1310 card provides one intermediate- or short-range OC-12 port and operates at 1310 nm. Note The OC12 IR 1310 and OC12/STM4 SH 1310 cards are functionally the same.	See the “4.1.4 OC12 IR/STM4 SH 1310 Card” section on page 4-11 .
OC12 IR/STM4 SH 1310	The OC12 IR/STM4 SH 1310 card provides one intermediate- or short-range OC-12 port and operates at 1310 nm.	See the “4.1.4 OC12 IR/STM4 SH 1310 Card” section on page 4-11 .
OC12 LR 1310	The OC12 LR 1310 card provides one long-range OC-12 port and operates at 1310 nm. Note The OC12 LR 1310 and OC12 LR/STM4 LH 1310 cards are functionally the same.	See the “4.1.5 OC12 LR/STM4 LH 1310 Card” section on page 4-14 .
OC12 LR/STM4 LH 1310	The OC12 LR/STM4 LH 1310 card provides one long-range OC-12 port and operates at 1310 nm.	See the “4.1.5 OC12 LR/STM4 LH 1310 Card” section on page 4-14 .
OC12 LR 1550	The OC12 LR 1550 card provides one long-range OC-12 port and operates at 1550 nm. Note The OC12 LR 1550 and OC12 LR/STM4 LH 1550 cards are functionally the same.	See the “4.1.6 OC12 LR/STM4 LH 1550 Card” section on page 4-17 .
OC12 LR/STM4 LH 1550	The OC12 LR/STM4 LH 1550 card provides one long-range OC-12 port and operates at 1550 nm.	See the “4.1.6 OC12 LR/STM4 LH 1550 Card” section on page 4-17 .
OC12 IR/STM4 SH 1310-4	The OC12 IR/STM4 SH 1310-4 card provides four intermediate- or short-range OC-12 ports and operates at 1310 nm.	See the “4.1.7 OC12 IR/STM4 SH 1310-4 Card” section on page 4-20 .

Table 4-1 OC-N Cards for the ONS 15454 (continued)

Card	Port Description	For Additional Information...
OC48 IR 1310	The OC48 IR 1310 card provides one intermediate-range OC-48 port and operates at 1310 nm.	See the “4.1.8 OC48 IR 1310 Card” section on page 4-24.
OC48 LR 1550	The OC48 LR 1550 card provides one long-range OC-48 port and operates at 1550 nm.	See the “4.1.9 OC48 LR 1550 Card” section on page 4-26.
OC48 IR/STM16 SH AS 1310	The OC48 IR/STM16 SH AS 1310 card provides one intermediate- or short-range OC-48 port at 1310 nm.	See the “4.1.10 OC48 IR/STM16 SH AS 1310 Card” section on page 4-29.
OC48 LR/STM16 LH AS 1550	The OC48 LR/STM16 LH AS 1550 card provides one long-range OC-48 port at 1550 nm.	See the “4.1.11 OC48 LR/STM16 LH AS 1550 Card” section on page 4-32.
OC48 ELR/STM16 EH 100 GHz	The OC48 ELR/STM16 EH 100 GHz card provides one long-range (enhanced) OC-48 port and operates in Slots 5, 6, 12, or 13. This card is available in 18 different wavelengths (9 in the blue band and 9 in the red band) in the 1550-nm range, every second wavelength in the ITU grid for 100-GHz spacing dense wavelength division multiplexing (DWDM).	See the “4.1.12 OC48 ELR/STM16 EH 100 GHz Cards” section on page 4-35.
OC48 ELR 200 GHz	The OC48 ELR 200 GHz card provides one long-range (enhanced) OC-48 port and operates in Slots 5, 6, 12, or 13. This card is available in 18 different wavelengths (9 in the blue band and 9 in the red band) in the 1550-nm range, every fourth wavelength in the ITU grid for 200-GHz spacing DWDM.	See the “4.1.13 OC48 ELR 200 GHz Cards” section on page 4-38.
OC192 SR/STM64 IO 1310	The OC192 SR/STM64 IO 1310 card provides one intra-office-haul OC-192 port at 1310 nm.	See the “4.1.14 OC192 SR/STM64 IO 1310 Card” section on page 4-41.
OC192 IR/STM64 SH 1550	The OC192 IR/STM64 SH 1550 card provides one intermediate-range OC-192 port at 1550 nm.	See the “4.1.15 OC192 IR/STM64 SH 1550 Card” section on page 4-45.
OC192 LR/STM64 LH 1550	The OC192 LR/STM64 LH 1550 card provides one long-range OC-192 port at 1550 nm.	See the “4.1.16 OC192 LR/STM64 LH 1550 Card” section on page 4-49.
OC192 LR/STM64 LH ITU 15xx.xx	The OC192 LR/STM64 LH ITU 15xx.xx card provides one extended long-range OC-192 port. This card is available in multiple wavelengths in the 1550-nm range of the ITU grid for 100-GHz-spaced DWDM.	See the “4.1.17 OC192 LR/STM64 LH ITU 15xx.xx Card” section on page 4-54.

**Note**

The Cisco OC3 IR/STM1 SH, OC12 IR/STM4 SH, and OC48 IR/STM16 SH interface optics, all working at 1310 nm, are optimized for the most widely used SMF-28 fiber, available from many suppliers.

Corning MetroCor fiber is optimized for optical interfaces that transmit at 1550 nm or in the C and L

DWDM windows, and targets interfaces with higher dispersion tolerances than those found in OC3 IR/STM1 SH, OC12 IR/STM4 SH, and OC48 IR/STM16 SH interface optics. If you are using Corning MetroCor fiber, OC3 IR/STM1 SH, OC12 IR/STM4 SH, and OC48 IR/STM16 SH interface optics become dispersion limited before they become attenuation limited. In this case, consider using OC12 LR/STM4 LH and OC48 LR/STM16 LH cards instead of OC12 IR/STM4 SH and OC48 IR/STM16 SH cards.

With all fiber types, network planners/engineers should review the relative fiber type and optics specifications to determine attenuation, dispersion, and other characteristics to ensure appropriate deployment.

4.1.2 OC3 IR 4/STM1 SH 1310 Card

The OC3 IR 4/STM1 SH 1310 card provides four intermediate or short range SONET/SDH OC-3 ports compliant with ITU-T G.707, ITU-T G.957, and Telcordia GR-253-CORE. Each port operates at 155.52 Mbps over a single-mode fiber span. The card supports VT and nonconcatenated or concatenated payloads at the STS-1 or STS-3c signal levels. [Figure 4-1](#) shows the OC3 IR 4/STM1 SH 1310 faceplate and a block diagram of the card.

**Note**

The OC3 IR 4 SH 1310 and OC3 IR 4/STM1 SH 1310 cards are functionally the same.

Figure 4-1 OC3 IR 4/STM1 SH 1310 Faceplate and Block Diagram

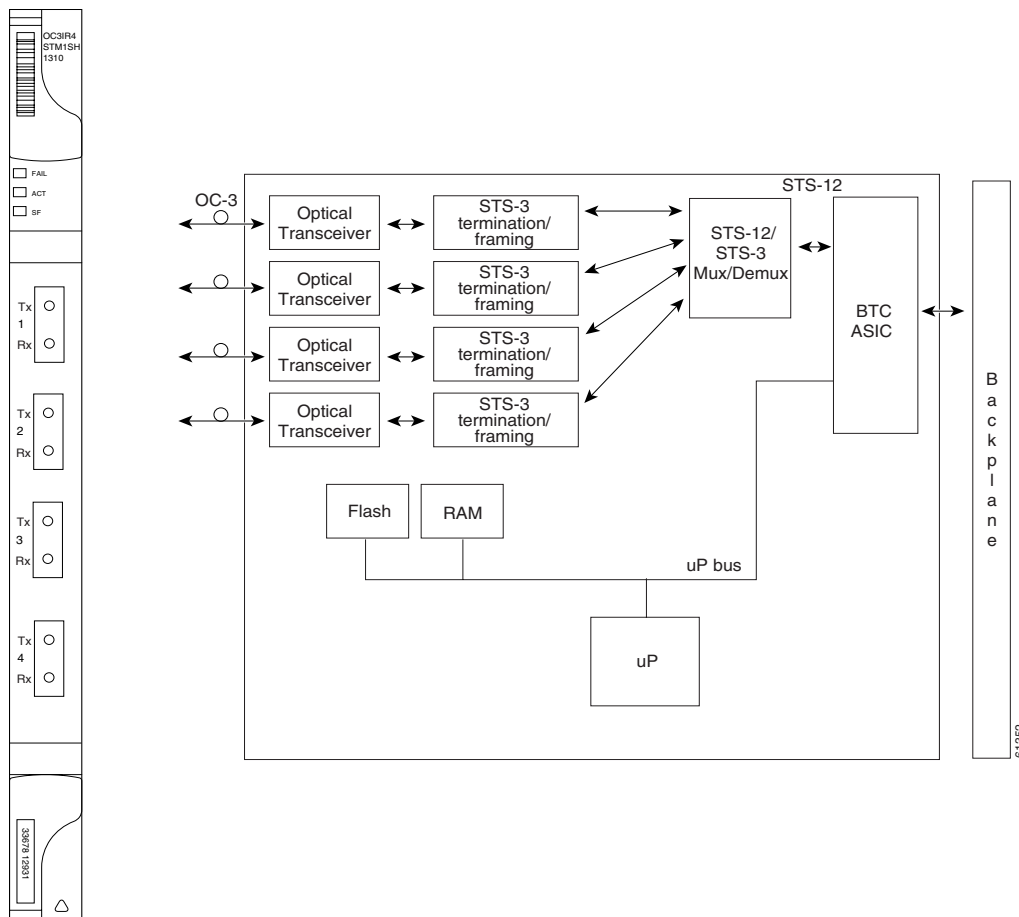

You can install the OC3 IR 4/STM1 SH 1310 card in Slots 1 to 6 and 12 to 17. The card can be provisioned as part of a path protector or in a linear add/drop multiplexer (ADM) configuration. Each interface features a 1310-nm laser and contains a transmit and receive connector (labeled) on the card faceplate. The card uses SC connectors.

The OC3 IR 4/STM1 SH 1310 card supports 1+1 unidirectional or bidirectional protection switching. You can provision protection on a per port basis.

The OC3 IR 4/STM1 SH 1310 card detects loss of signal (LOS), loss of frame (LOF), loss of pointer (LOP), line-layer alarm indication signal (AIS-L), and line-layer remote defect indication (RDI-L) conditions. Refer to the *Cisco ONS 15454 Troubleshooting Guide* for a description of these conditions. The card also counts section and line bit interleaved parity (BIP) errors.

To enable automatic protection switching (APS), the OC3 IR 4/STM1 SH 1310 card extracts the K1 and K2 bytes from the SONET overhead to perform appropriate protection switches. The data communication channel/general communication channel (DCC/GCC) bytes are forwarded to the TCC2 card, which terminates the DCC/GCC.

4.1.2.1 OC3 IR 4/STM1 SH 1310 Card-Level Indicators

The OC3 IR 4/STM1 SH 1310 card has three card-level LED indicators, described in [Table 4-2](#).

Table 4-2 OC3 IR 4/STM1 SH 1310 Card-Level Indicators

Card-Level Indicators	Description
Red FAIL LED	The red FAIL LED indicates that the card's processor is not ready. This LED is on during reset. The FAIL LED flashes during the boot process. Replace the card if the red FAIL LED persists.
Green ACT LED	The green ACT LED indicates that the card is carrying traffic or is traffic-ready.
Amber SF LED	The amber SF LED indicates a signal failure or condition such as loss of signal (LOS), loss of frame (LOF), line alarm indicator signal (AIS-L), or high BER on one or more of the card's ports. The amber SF LED is also on if the transmit and receive fibers are incorrectly connected. If the fibers are properly connected and the links are working, the light turns off.

4.1.2.2 OC3 IR 4/STM1 SH 1310 Port-Level Indicators

Eight bicolor LEDs show the status per port. The LEDs show green if the port is available to carry traffic, is provisioned as in-service, and is part of a protection group, in the active mode. You can find the status of the four card ports using the LCD screen on the ONS 15454 fan-tray assembly. Use the LCD to view the status of any port or card slot; the screen displays the number and severity of alarms for a given port or slot. Refer to the *Cisco ONS 15454 Troubleshooting Guide* for a complete description of the alarm messages.

4.1.2.3 OC3 IR 4/STM1 SH 1310 Card Specifications

The OC3 IR 4/STM1 SH 1310 card has the following specifications:

- Line
 - Bit rate: 155.52 Mbps
 - Code: Scrambled non-return to zero (NRZ)
 - Fiber: 1310-nm single-mode
 - Loopback modes: Terminal and facility
 - Connector: SC
 - Compliance: Telcordia GR-253-CORE, ITU-T G.707, ITU-T G.957
- Transmitter
 - Maximum transmitter output power: –8 dBm
 - Minimum transmitter output power: –15 dBm
 - Center wavelength: 1274 to 1356 nm
 - Nominal wavelength: 1310 nm
 - Transmitter: Fabry Perot laser
 - Extinction Ratio: 8.2 dB

- Dispersion Ratio: 96 ps/nm
- Receiver
 - Maximum receiver level: -8 dBm at BER $1 * 10^{exp - 12}$
 - Minimum receiver level: -28 dBm at BER $1 * 10^{exp - 12}$
 - Receiver: InGaAs/InP photodetector
 - Link loss budget: 13 dB
 - Receiver input wavelength range: 1274 to 1356 nm
 - Jitter tolerance: Telcordia GR-253/ITU-T G.823 compliant
- Environmental
 - Operating temperature:
 - C-Temp (15454-OC34IR1310): -5 to +45 degrees Celsius (+23 to +113 degrees Fahrenheit)
 - I-Temp (15454-OC34I13-T): -40 to +65 degrees Celsius (-40 to +149 degrees Fahrenheit)
 - Operating humidity: 5 to 95%, noncondensing
 - Power consumption: 19.20 W, 0.40 A at -48 V, 65.56 BTU/hr
- Dimensions
 - Height: 12.650 in. (321.3 mm)
 - Width: 0.716 in. (18.2 mm)
 - Depth: 9.000 in. (228.6 mm)
 - Depth with backplane connector: 9.250 in. (235 mm)
 - Weight not including clam shell: 1.0 lb (0.4 kg)
- Compliance
 - For compliance information, refer to the *Cisco Optical Transport Products Safety and Compliance Information*.

4.1.3 OC3 IR/STM1 SH 1310-8 Card

The OC3 IR/STM1 SH 1310-8 card provides eight intermediate or short range SONET/SDH OC-3 ports compliant with ITU-T G.707, ITU-T G.957, and Telcordia GR-253-CORE. Each port operates at 155.52 Mbps over a single-mode fiber span. The card supports VT and nonconcatenated or concatenated payloads at the STS-1 or STS-3c signal levels. [Figure 4-2](#) shows the card faceplate.

Figure 4-2 OC3IR/STM1 SH 1310-8 Faceplate

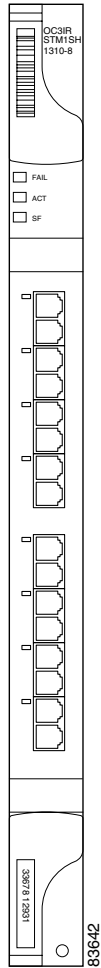
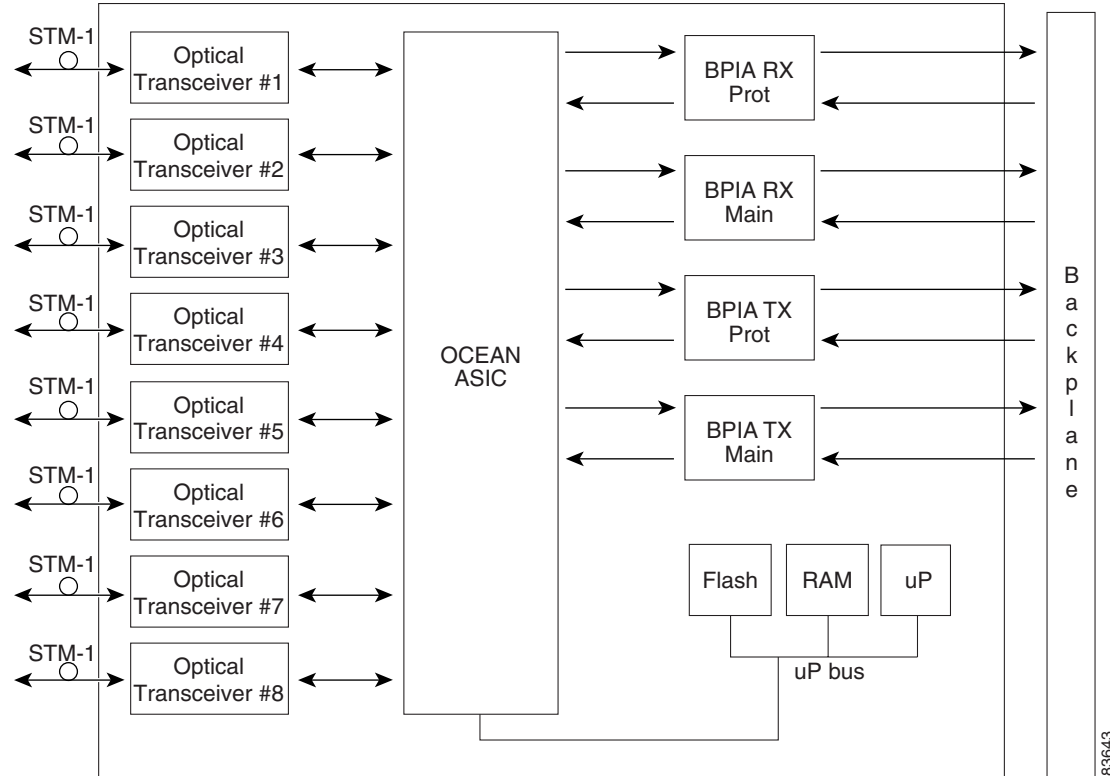

Figure 4-3 shows a block diagram of the OC3 IR/STM1 SH 1310-8 card.

Figure 4-3 OC3IR/STM1 SH 1310-8 Block Diagram



You can install the OC3 IR/STM1 SH 1310-8 card in Slots 1 to 4 and 14 to 17. The card can be provisioned as part of a path protection or in an add/drop multiplexer/terminal monitor (ADM/TM) configuration. Each interface features a 1310-nm laser and contains a transmit and receive connector (labeled) on the card faceplate. The card uses LC connectors on the faceplate, angled downward 12.5 degrees.

The OC3 IR/STM1 SH 1310-8 card supports 1+1 unidirectional and bidirectional protection switching. You can provision protection on a per port basis.

The OC3 IR/STM1 SH 1310-8 card detects LOS, LOF, LOP, AIS-L, and RDI-L conditions. Refer to the *Cisco ONS 15454 Troubleshooting Guide* for a description of these conditions. The card also counts section and line BIP errors.

To enable APS, the OC3 IR/STM1 SH 1310-8 card extracts the K1 and K2 bytes from the SONET overhead to perform appropriate protection switches. The OC3 IR/STM1 SH 1310-8 card supports full DCC/GCC connectivity for remote network management.

4.1.3.1 OC3 IR/STM1 SH 1310-8 Card-Level Indicators

Table 4-3 describes the three card-level LEDs on the eight-port OC3 IR/STM1 SH 1310-8 card.

Table 4-3 OC3IR/STM1 SH 1310-8 Card-Level Indicators

Card-Level LED	Description
Red FAIL LED	The red FAIL LED indicates that the card's processor is not ready. This LED is on during reset. The FAIL LED flashes during the boot process. Replace the card if the red FAIL LED persists.
Green ACT LED	The green ACT LED indicates that the card is carrying traffic or is traffic-ready.
Amber SF LED	The amber SF LED indicates a signal failure or condition such as LOS, LOF, AIS-L, or high BER on one or more of the card's ports. The amber SF LED is also on if the transmit and receive fibers are incorrectly connected. If the fibers are properly connected and the links are working, the light turns off.

4.1.3.2 OC3 IR/STM1 SH 1310-8 Port-Level Indicators

Eight bicolor LEDs show the status per port. The LEDs shows green if the port is available to carry traffic, is provisioned as in-service, and is part of a protection group, in the active mode. You can also find the status of the eight card ports using the LCD screen on the ONS 15454 fan-tray assembly. Use the LCD to view the status of any port or card slot; the screen displays the number and severity of alarms for a given port or slot. Refer to the *Cisco ONS 15454 Troubleshooting Guide* for a complete description of the alarm messages.

4.1.3.3 OC3 IR/STM1SH 1310-8 Card Specifications

The OC3IR/STM1 SH 1310-8 card has the following specifications:

- Line
 - Bit rate: 155.52 Mbps
 - Code: Scrambled NRZ
 - Fiber: 1310-nm single-mode
 - Loopback modes: Terminal and facility
 - Connector: LC
 - Compliance: Telcordia GR-253-CORE, ITU-T G.707, ITU-T G.957
- Transmitter
 - Maximum transmitter output power: –8 dBm
 - Minimum transmitter output power: –15 dBm
 - Center wavelength: 1261 to 1360 nm
 - Nominal wavelength: 1310 nm
 - Transmitter: Fabry Perot laser

- Extinction ratio: 8.2 dB
- Dispersion tolerance: 96 ps/nm
- Receiver
 - Maximum receiver level: -8 dBm at BER $1 * 10 \text{ exp} - 12$
 - Minimum receiver level: -28 dBm at BER $1 * 10 \text{ exp} - 12$
 - Receiver: InGaAs/InP photodetector
 - Link loss budget: 13 dB
 - Receiver input wavelength range: 1261 to 1360 nm
 - Jitter tolerance: Telcordia GR-253/ITU-T G.823 compliant
- Environmental
 - Operating temperature: -5 to +45 degrees Celsius (+23 to +113 degrees Fahrenheit)
 - Operating humidity: 5 to 95%, noncondensing
 - Power consumption: 23.00 W, 0.48 A at -48 V, 78.5 BTU/hr
- Dimensions
 - Height: 12.650 in. (321.3 mm)
 - Width: 0.716 in. (18.2 mm)
 - Depth: 9.000 in. (228.6 mm)
 - Depth with backplane connector: 9.250 in. (235 mm)
 - Weight not including clam shell: 1.0 lb (0.4 kg)
- Compliance
 - For compliance information, refer to the *Cisco Optical Transport Products Safety and Compliance Information*.

4.1.4 OC12 IR/STM4 SH 1310 Card

The OC12 IR/STM4 SH 1310 card provides one intermediate or short range SONET OC-12 port compliant with ITU-T G.707, ITU-T G.957, and Telcordia GR-253-CORE. The port operates at 622.08 Mbps over a single-mode fiber span. The card supports VT and nonconcatenated or concatenated payloads at STS-1, STS-3c, STS-6c, or STS-12c signal levels. [Figure 4-4](#) shows the OC12 IR/STM4 SH 1310 faceplate and a block diagram of the card.

**Note**

The OC12 IR 1310 and OC12/STM4 SH 1310 cards are functionally the same.

Figure 4-4 OC12 IR/STM4 SH 1310 Faceplate and Block Diagram

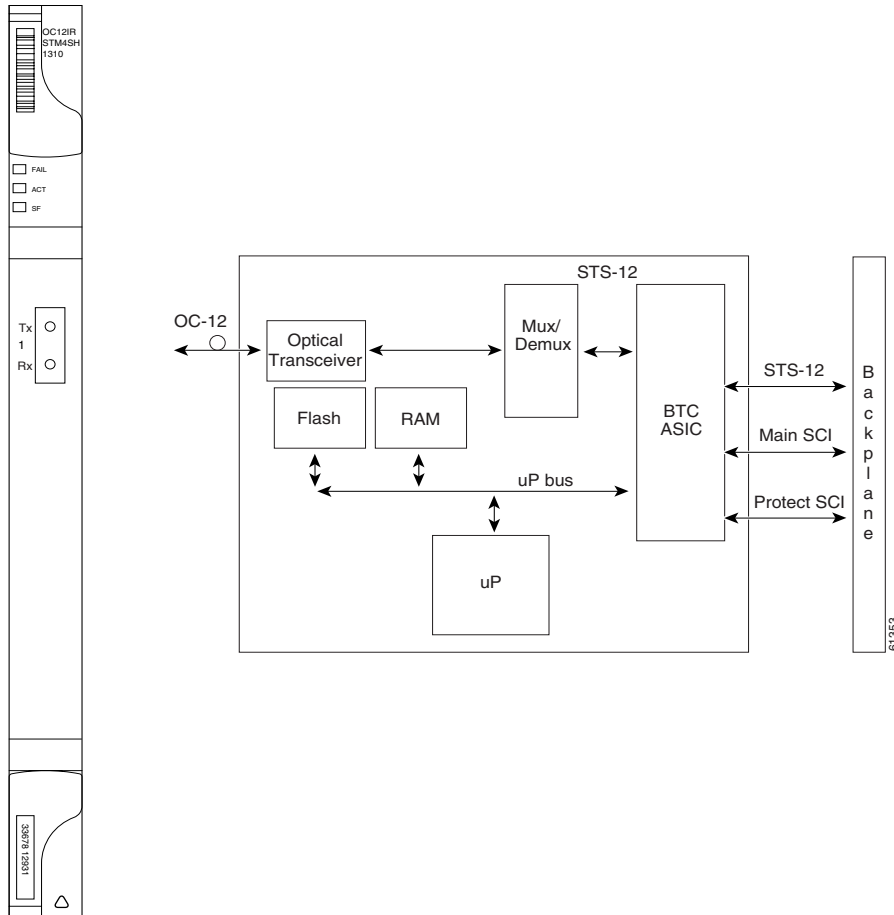

You can install the OC12 IR/STM4 SH 1310 card in Slots 1 to 6 and 12 to 17, and provision the card as a drop card or span card in a two-fiber BLSR, path protection, or ADM (linear) configuration.

The OC12 IR/STM4 SH 1310 card interface features a 1310-nm laser and contains a transmit and receive connector (labeled) on the card faceplate. The OC12 IR/STM4 SH 1310 card uses SC optical connections and supports 1+1 unidirectional and bidirectional protection.

The OC12 IR/STM4 SH 1310 detects LOS, LOF, LOP, AIS-L, and RDI-L conditions. Refer to the *Cisco ONS 15454 Troubleshooting Guide* for a description of these conditions. The card also counts section and line BIT errors.

To enable APS, the OC12 IR/STM4 SH 1310 card extracts the K1 and K2 bytes from the SONET overhead to perform appropriate protection switches. The DCC/GCC bytes are forwarded to the TCC2 card, which terminates the DCC/GCC.

4.1.4.1 OC12 IR/STM4 SH 1310 Card-Level Indicators

Table 4-4 describes the three card-level LEDs on the OC12 IR/STM4 SH 1310 card.

Table 4-4 OC12 IR/STM4 SH 1310 Card-Level Indicators

Card-Level Indicators	Description
Red FAIL LED	The red FAIL LED indicates that the card's processor is not ready. This LED is on during reset. The FAIL LED flashes during the boot process. Replace the card if the red FAIL LED persists.
Green ACT LED	The green ACT LED indicates that the card is operational and is carrying traffic or is traffic-ready.
Amber SF LED	The amber SF LED indicates a signal failure or condition such as LOS, LOF, AIS-L, or high BERs on one or more of the card's ports. The amber SF LED is also on if the transmit and receive fibers are incorrectly connected. If the fibers are properly connected and the link is working, the light turns off.

4.1.4.2 OC12 IR/STM4 SH 1310 Port-Level Indicators

You can find the status of the OC-12 IR/STM4 SH 1310 card port using the LCD screen on the ONS 15454 fan-tray assembly. Use the LCD to view the status of any port or card slot; the screen displays the number and severity of alarms for a given port or slot. Refer to the *Cisco ONS 15454 Troubleshooting Guide* for a complete description of the alarm messages.

4.1.4.3 OC12 IR/STM4 SH 1310 Card Specifications

The OC12 IR/STM4 SH 1310 card has the following specifications:

- Line
 - Bit rate: 622.08 Mbps
 - Code: Scrambled NRZ
 - Fiber: 1310-nm single-mode
 - Loopback modes: Terminal and facility
 - Connectors: SC
 - Compliance: Telcordia GR-253-CORE, ITU-T G.707, ITU-T G.957
- Transmitter
 - Maximum transmitter output power: -8 dBm
 - Minimum transmitter output power: -15 dBm
 - Center wavelength: 1274 to 1356 nm
 - Nominal wavelength: 1310 nm
 - Transmitter: Fabry Perot laser
 - Extinction ratio: 8.2 dB
 - Dispersion tolerance: 96 ps/nm
- Receiver
 - Maximum receiver level: -8 dBm at BER $1 * 10^{exp - 12}$
 - Minimum receiver level: -28 dBm at BER $1 * 10^{exp - 12}$
 - Receiver: InGa As/InP photodetector

- Link loss budget: 13 dB
- Receiver input wavelength range: 1274 to 1356 nm
- Jitter tolerance: Telcordia GR-253/ITU-T G.823 compliant
- Environmental
 - Operating temperature:
 - C-Temp (15454-OC121IR1310): -5 to +55 degrees Celsius (+23 to +131 degrees Fahrenheit)
 - I-Temp (15454-OC121I13-T): -40 to +65 degrees Celsius (-40 to +149 degrees Fahrenheit)
 - Operating humidity: 5 to 95%, noncondensing
 - Power consumption: 10.90 W, 0.23 A at -48 V, 37.22 BTU/hr
- Dimensions
 - Height: 12.650 in. (321.3 mm)
 - Width: 0.716 in. (18.2 mm)
 - Depth: 9.000 in. (228.6 mm)
 - Weight not including clam shell: 1.4 lb (0.6 kg)
- Compliance
 - For compliance information, refer to the *Cisco Optical Transport Products Safety and Compliance Information*.

4.1.5 OC12 LR/STM4 LH 1310 Card

The OC12 LR/STM4 LH 1310 card provides one long-range SONET OC-12 port per card compliant with ITU-T G.707, ITU-T G.957, and Telcordia GR-253-CORE. The port operates at 622.08 Mbps over a single-mode fiber span. The card supports VT and nonconcatenated or concatenated payloads at STS-1, STS-3c, STS-6c, or STS-12c signal levels. [Figure 4-5](#) shows the OC12 LR/STM4 LH 1310 faceplate and a block diagram of the card.



Note

The OC12 LR 1310 and OC12 LR/STM4 LH 1310 cards are functionally the same.

Figure 4-5 OC12 LR/STM4 LH 1310 Faceplate and Block Diagram

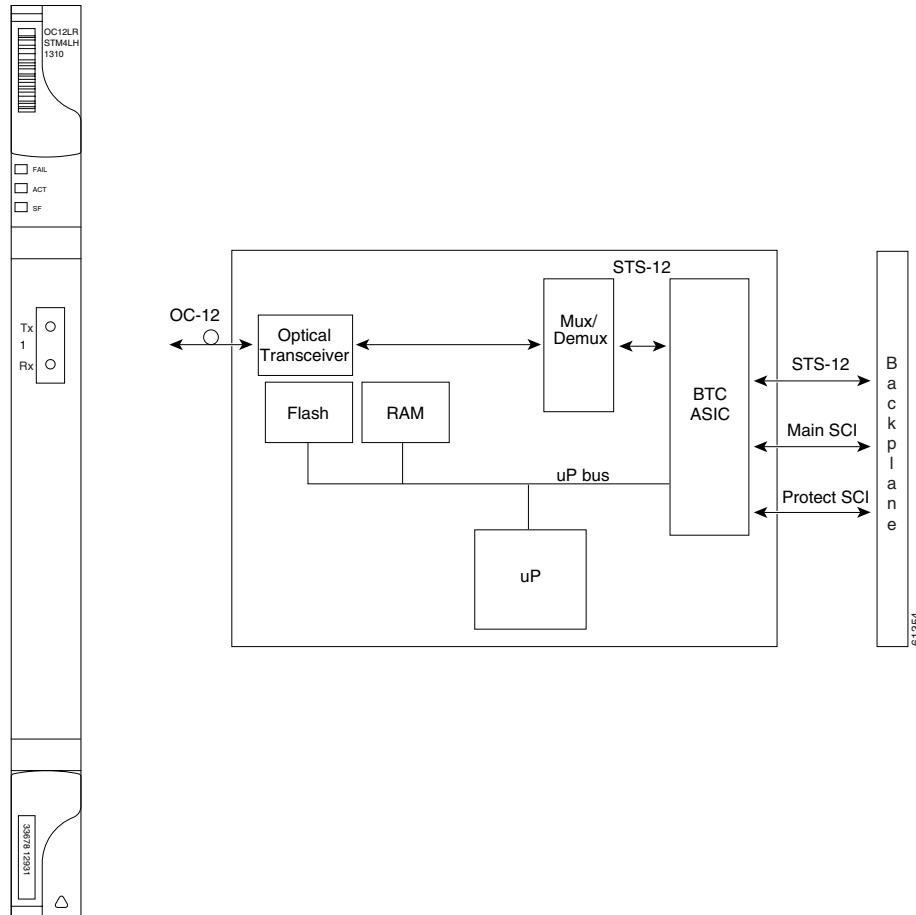

You can install the OC12 LR/STM4 LH 1310 card in Slots 1 to 6 and 12 to 17, and provision the card as a drop card or span card in a two-fiber BLSR, path protection, or ADM (linear) configuration.

The OC12 LR/STM4 LH 1310 card interface features a 1310-nm laser and contains a transmit and receive connector (labeled) on the card faceplate. The card uses SC optical connections and supports 1+1 unidirectional and bidirectional protection.

The OC12 LR/STM4 LH 1310 card detects LOS, LOF, LOP, AIS-L, and RDI-L conditions. Refer to the *Cisco ONS 15454 Troubleshooting Guide* for a description of these conditions. The card also counts section and line BIT errors.

To enable APS, the OC12 LR/STM4 LH 1310 card extracts the K1 and K2 bytes from the SONET overhead to perform appropriate protection switches. The DCC/GCC bytes are forwarded to the TCC2 card, which terminates the DCC/GCC.

4.1.5.1 OC12 LR/STM4 LH 1310 Card-Level Indicators

Table 4-5 describes the three card-level LEDs on the OC12 LR/STM4 LH 1310 card.

Table 4-5 OC12 LR/STM4 LH 1310 Card-Level Indicators

Card-Level Indicators	Description
Red FAIL LED	The red FAIL LED indicates that the card's processor is not ready. Replace the card if the red FAIL LED persists.
Green ACT LED	The green ACT LED indicates that the card is operational and is carrying traffic or is traffic-ready.
Amber SF LED	The amber SF LED indicates a signal failure or condition such as LOS, LOF, AIS-L, or high BERs on the card's port. The amber SF LED is also on if the transmit and receive fibers are incorrectly connected. If the fibers are properly connected, the light turns off.

4.1.5.2 OC12 LR/STM4 LH 1310 Port-Level Indicators

You can find the status of the OC12 LR/STM4 LH 1310 card port using the LCD screen on the ONS 15454 fan-tray assembly. Use the LCD to quickly view the status of any port or card slot; the screen displays the number and severity of alarms for a given port or slot.



Warning

Invisible laser radiation may be emitted from the end of the unterminated fiber cable or connector. Do not stare into the beam or view directly with optical instruments. Viewing the laser output with certain optical instruments (for example, eye loupes, magnifiers, and microscopes) within a distance of 100 mm may pose an eye hazard. Use of controls or adjustments or performance of procedures other than those specified may result in hazardous radiation exposure.

4.1.5.3 OC12 LR/STM4 LH 1310 Card Specifications

The OC12 LR/STM4 LH 1310 card has the following specifications:

- Line
 - Bit rate: 622.08 Mbps
 - Code: Scrambled NRZ
 - Fiber: 1310-nm single-mode
 - Loopback modes: Terminal and facility
 - Connectors: SC
 - Compliance: Telcordia SONET, GR-253-CORE, ITU-T G.707, ITU-T G.957
- Transmitter
 - Maximum transmitter output power: +2 dBm
 - Minimum transmitter output power: -3 dBm
 - Center wavelength: 1280 to 1335 nm
 - Nominal wavelength: 1310 nm
 - Transmitter: Distributed feedback (DFB) laser

- Extinction ratio: 10 dB
- Dispersion tolerance: 190 ps/nm
- Receiver
 - Maximum receiver level: –8 dBm at BER $1 * 10 \text{ exp} - 12$
 - Minimum receiver level: –28 dBm at BER $1 * 10 \text{ exp} - 12$
 - Receiver: InGaAs/InP photodetector
 - Link loss budget: 25 dB
 - Receiver input wavelength range: 1280 to 1335 nm
 - Jitter tolerance: Telcordia GR-253/ITU-T G.823 compliant
- Environmental
 - Operating temperature:
 - C-Temp (15454-OC121LR1310): –5 to +55 degrees Celsius (+23 to +131 degrees Fahrenheit)
 - I-Temp (15454-OC121L13-T): –40 to +65 degrees Celsius (–40 to +149 degrees Fahrenheit)
 - Operating humidity: 5 to 95%, noncondensing
 - Power consumption: 9.28 W, 0.25 A, 41 BTU/hr
- Dimensions
 - Height: 12.650 in. (321.3 mm)
 - Width: 0.716 in. (18.2 mm)
 - Depth: 9.000 in. (228.6 mm)
 - Weight not including clam shell: 1.4 lb (0.6 kg)
- Compliance
 - For compliance information, refer to the *Cisco Optical Transport Products Safety and Compliance Information*.

4.1.6 OC12 LR/STM4 LH 1550 Card

The OC12 LR/STM4 LH 1550 card provides one long-range SONET/SDH OC-12 port compliant with ITU-T G.707, ITU-T G.957, and Telcordia GR-253-CORE. The port operates at 622.08 Mbps over a single-mode fiber span. The card supports VT and nonconcatenated or concatenated payloads at STS-1, STS-3c, STS-6c, or STS-12c signal levels. [Figure 4-6](#) shows the OC12 LR/STM4 LH 1550 faceplate and a block diagram of the card.



Note

The OC12 LR 1550 and OC12 LR/STM4 LH 1550 cards are functionally the same.

Figure 4-6 OC12 LR/STM4 LH 1550 Faceplate and Block Diagram

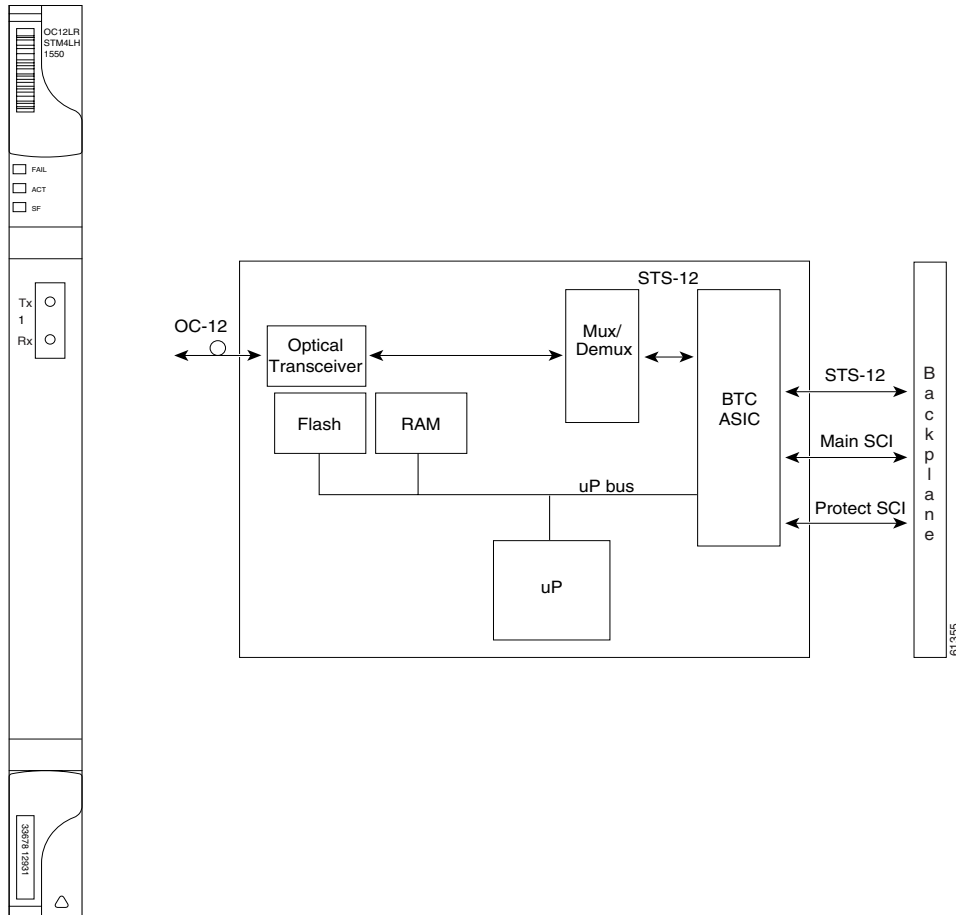

You can install the OC12 LR/STM4 LH 1550 card in Slots 1 to 4 and 14 to 17. The OC12 LR/STM4 LH 1550 can be provisioned as part of a two-fiber BLSR, path protection, or linear ADM.

The OC12 LR/STM4 LH 1550 uses long-reach optics centered at 1550 nm and contains a transmit and receive connector (labeled) on the card faceplate. The OC12 LR/STM4 LH 1550 uses SC optical connections and supports 1+1 bidirectional or unidirectional protection switching.

The OC12 LR/STM4 LH 1550 detects LOS, LOF, LOP, AIS-L, and RDI-L conditions. The card also counts section and line BIT errors.

4.1.6.1 OC12 LR/STM4 LH 1550 Card-Level Indicators

Table 4-6 describes the three card-level LEDs on the OC12 LR/STM4 LH 1550 card.

Table 4-6 OC12 LR/STM4 LH 1550 Card-Level Indicators

Card-Level Indicators	Description
Red FAIL LED	The red FAIL LED indicates that the card's processor is not ready. Replace the card if the red FAIL LED persists.
Green ACT LED	The green ACT LED indicates that the card is operational and ready to carry traffic.
Amber SF LED	The amber SF LED indicates a signal failure or condition such as LOS, LOF, AIS-L, or high BERs on the card's port. The amber SF LED is also on if the transmit and receive fibers are incorrectly connected. If the fibers are properly connected, the light turns off.

4.1.6.2 OC12 LR/STM4 LH 1550 Port-Level Indicators

You can find the status of the OC12 LR/STM4 LH 1550 card port using the LCD screen on the ONS 15454 fan-tray assembly. Use the LCD to view the status of any port or card slot; the screen displays the number and severity of alarms for a given port or slot.



Warning

Invisible laser radiation may be emitted from the end of the unterminated fiber cable or connector. Do not stare into the beam or view directly with optical instruments. Viewing the laser output with certain optical instruments (for example, eye loupes, magnifiers, and microscopes) within a distance of 100 mm may pose an eye hazard. Use of controls or adjustments or performance of procedures other than those specified may result in hazardous radiation exposure.

4.1.6.3 OC12 LR/STM4 LH 1550 Card Specifications

The OC12 LR/STM4 LH 1550 card has the following specifications:

- Line
 - Bit rate: 622.08 Mbps
 - Code: Scrambled NRZ
 - Fiber: 1550-nm single-mode
 - Loopback modes: Terminal and facility
 - Connectors: SC
 - Compliance: Telcordia SONET, GR-253-CORE, ITU-T G.707, ITU-T G.957
- Transmitter
 - Maximum transmitter output power: +2 dBm
 - Minimum transmitter output power: -3 dBm
 - Center wavelength: 1480 to 1580 nm
 - Nominal wavelength: 1550 nm
 - Transmitter: DFB laser
 - Dispersion tolerance: 1440 ps/nm

- Receiver
 - Maximum receiver level: -8 dBm at BER $1 * 10 \text{ exp} - 12$
 - Minimum receiver level: -28 dBm at BER $1 * 10 \text{ exp} - 12$
 - Receiver: InGaAs/InP photodetector
 - Link loss budget: 25 dB
 - Receiver input wavelength range: 1480 to 1580 nm
 - Jitter tolerance: Telcordia GR-253/ITU-T G.823 compliant
- Environmental
 - Operating temperature:
 - C-Temp (15454-OC121LR1550): -5 to $+55$ degrees Celsius ($+23$ to $+131$ degrees Fahrenheit)
 - I-Temp (15454-OC121L15-T): -40 to $+65$ degrees Celsius (-40 to $+149$ degrees Fahrenheit)
 - Operating humidity: 5 to 95%, noncondensing
 - Power consumption: 9.28 W, 0.19 A, 31.68 BTU/hr
- Dimensions
 - Height: 12.650 in. (321.3 mm)
 - Width: 0.716 in. (18.2 mm)
 - Depth: 9.000 in. (228.6 mm)
 - Weight not including clam shell: 1.4 lb (0.6 kg)
- Compliance
 - For compliance information, refer to the *Cisco Optical Transport Products Safety and Compliance Information*.

4.1.7 OC12 IR/STM4 SH 1310-4 Card

The OC12 IR/STM4 SH 1310-4 card provides four intermediate or short range SONET/SDH OC-12/STM-4 ports compliant with the ITU-T G.707, ITU-T G.957, and Telcordia GR-253-CORE. Each port operates at 622.08 Mbps over a single-mode fiber span. The card supports VT and nonconcatenated or concatenated payloads at the STS-1, STS-3c, STS-6c, or STS-12c signal levels.

[Figure 4-7](#) shows the OC12 IR/STM4 SH 1310-4 faceplate and a block diagram of the card.

Figure 4-7 OC12 IR/STM4 SH 1310-4 Faceplate and Block Diagram

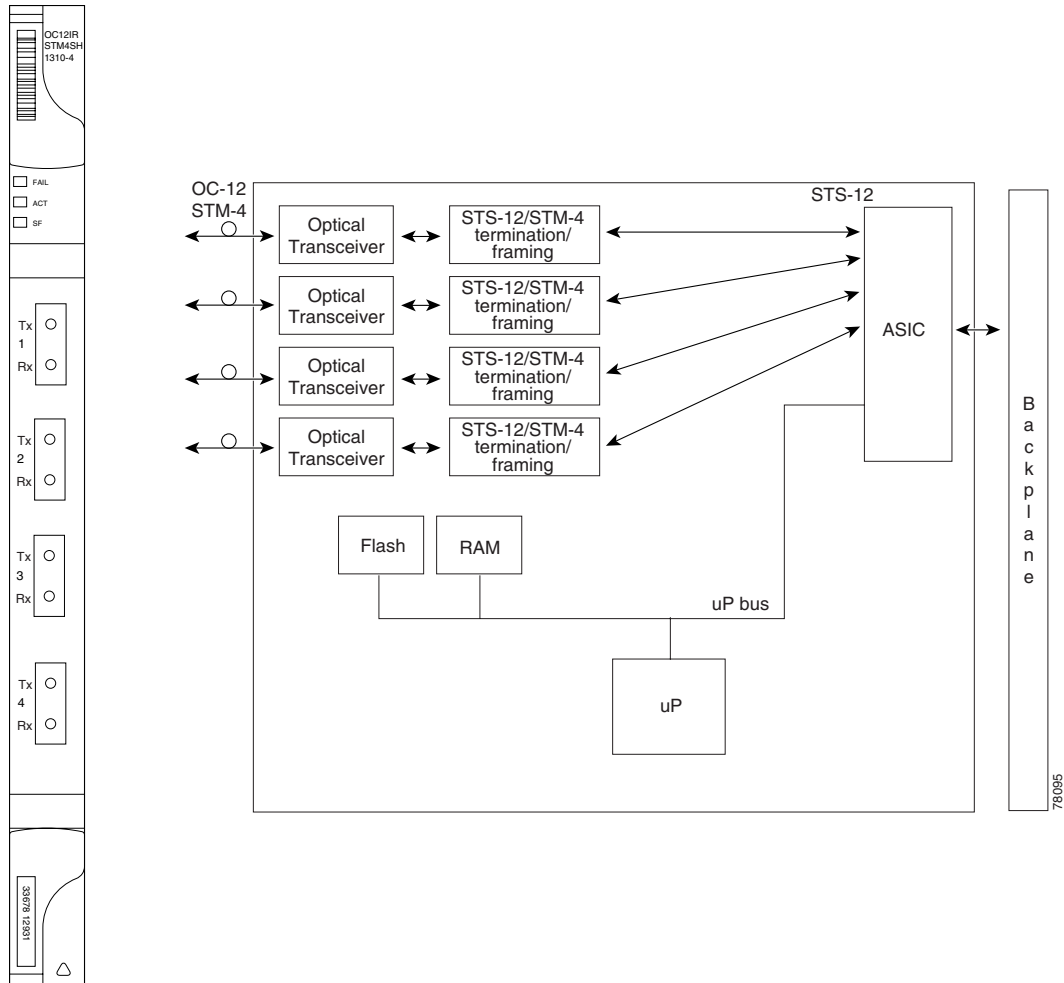
**Warning**

Invisible laser radiation may be emitted from disconnected fibers or connectors. Do not stare into beams or view directly with optical instruments.

You can install the OC12 IR/STM4 SH 1310-4 card in Slots 1 to 4 and 14 to 17. The card can be provisioned as part of an SNCP, part of a multiplex section-shared protection ring (MS-SPRing), or in an ADM/TM configuration. Each interface features a 1310-nm laser and contains a transmit and receive connector (labeled) on the card faceplate. The card uses SC connectors.

The OC12 IR/STM4 SH 1310-4 card supports 1+1 unidirectional and bidirectional protection switching. You can provision protection on a per port basis.

The OC12 IR/STM4 SH 1310-4 card detects LOS, LOF, LOP, MS-AIS, and MS-FERF conditions. Refer to the *Cisco ONS 15454 SDH Reference Manual* for a description of these conditions. The card also counts section and line BIP errors.

Each port is configurable to support all ONS 15454 SDH configurations and can be provisioned as part of an MS-SPRing, SNCP, or MSP configuration.

To enable MSP, the OC12 IR/STM4 SH 1310-4 card extracts the K1 and K2 bytes from the SDH overhead and processes them to switch accordingly. The DCC/GCC bytes are forwarded to the TCC2 card, which terminates the DCC/GCC.

**Note**

If you ever expect to upgrade an OC-12/STM-4 ring to a higher bit rate, you should not put an OC12 IR/STM4 SH 1310-4 card in that ring. The four-port card is not upgradable to a single-port card. The reason is that four different spans, possibly going to four different nodes, cannot be merged to a single span.

4.1.7.1 OC12 IR/STM4 SH 1310-4 Card-Level Indicators

Table 4-7 describes the three card-level LEDs on the OC12 IR/STM4 SH 1310-4 card.

Table 4-7 OC12 IR/STM4 SH 1310-4 Card-Level Indicators

Card-Level Indicators	Description
Red FAIL LED	The red FAIL LED indicates that the card's processor is not ready. Replace the card if the red FAIL LED persists.
Green ACT LED	The green ACT LED indicates that the card is carrying traffic or is traffic-ready.
Amber SF LED	The amber SF LED indicates a signal failure or condition such as LOS, LOF, AIS-L, or high BER on one or more of the card's ports. The amber SF LED is also on if the transmit and receive fibers are incorrectly connected. If the fibers are properly connected, the light turns off.

4.1.7.2 OC12 IR/STM4 SH 1310-4 Port-Level Indicators

You can find the status of the four card ports using the LCD screen on the ONS 15454 fan-tray assembly. Use the LCD to view the status of any port or card slot; the screen displays the number and severity of alarms for a given port or slot.

**Warning**

Invisible laser radiation may be emitted from the end of the unterminated fiber cable or connector. Do not stare into the beam or view directly with optical instruments. Viewing the laser output with certain optical instruments (for example, eye loupes, magnifiers, and microscopes) within a distance of 100 mm may pose an eye hazard. Use of controls or adjustments or performance of procedures other than those specified may result in hazardous radiation exposure.

4.1.7.3 OC12 IR/STM4 SH 1310-4 Specifications

The OC12 IR/STM4 SH 1310-4 card has the following specifications:

- Line
 - Bit rate: 622.08 Mbps
 - Code: Scrambled NRZ
 - Fiber: 1310-nm single-mode
 - Loopback modes: Terminal and facility

- Connector: SC
- Compliance: Telcordia GR-253-CORE, ITU-T G.707, ITU-T G.957
- Transmitter
 - Maximum transmitter output power: -8 dBm
 - Minimum transmitter output power: -15 dBm
 - Center wavelength: 1274 to 1356 nm
 - Nominal wavelength: 1310 nm
 - Transmitter: Fabry Perot laser
 - Extinction ratio: 10 dB
 - Dispersion tolerance: 190 ps/nm
- Receiver
 - Maximum receiver level: -8 dBm
 - Minimum receiver level: -30 dBm
 - Receiver: InGaAs/InP photodetector
 - Link loss budget: 15 dB
 - Receiver input wavelength range: 1274 to 1356 nm
 - Jitter tolerance: Telcordia GR-253/ITU-T G.823 compliant
- Operating temperature
 - C-Temp: -5 to +55 degrees Celsius (+23 to +131 degrees Fahrenheit)
- Operating humidity
 - 5 to 95%, noncondensing
- Power consumption
 - 28 W, 0.58 A, 100 BTU/hr
- Dimensions
 - Height: 12.650 in. (321.3 mm)
 - Width: 0.716 in. (18.2 mm)
 - Depth: 9.000 in. (228.6 mm)
 - Weight not including clam shell: 1.0 lb (0.4 kg)
- Compliance
 - For compliance information, refer to the *Cisco Optical Transport Products Safety and Compliance Information*.

**Note**

Minimum transmit power, Minimum receive power, and link loss budget might exceed standard specifications.

4.1.8 OC48 IR 1310 Card

The OC48 IR 1310 card provides one intermediate-range, SONET OC-48 port per card, compliant with Telcordia GR-253-CORE. Each port operates at 2.49 Gbps over a single-mode fiber span. The card supports VT and nonconcatenated or concatenated payloads at STS-1, STS-3c, STS-6c, STS-12c, or STS-48c signal levels. Figure 4-8 shows the OC48 IR 1310 faceplate and a block diagram of the card.

Figure 4-8 OC48 IR 1310 Faceplate and Block Diagram

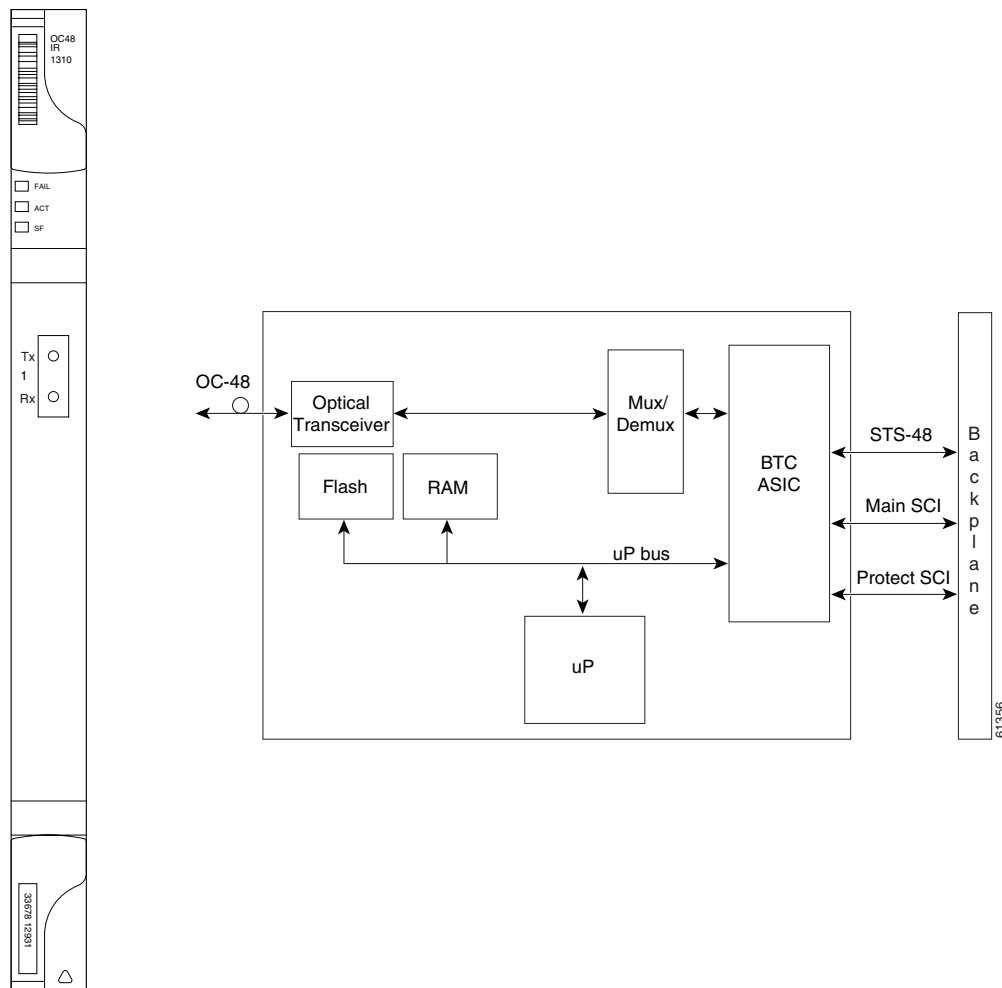

You can install the OC48 IR 1310 card in Slots 5, 6, 12, and 13, and provision the card as a drop or span card in a two-fiber or four-fiber BLSR, path protection, or in an ADM (linear) configuration.

The OC-48 port features a 1310-nm laser and contains a transmit and receive connector (labeled) on the card faceplate. The OC48 IR 1310 uses SC connectors. The card supports 1+1 unidirectional and bidirectional protection switching.

The OC48 IR 1310 detects LOS, LOF, LOP, AIS-L, and RDI-L conditions. The card also counts section and line BIP errors.

4.1.8.1 OC48 IR 1310 Card-Level Indicators

Table 4-8 describes the three card-level LEDs on the OC48 IR 1310 card.

Table 4-8 OC48 IR 1310 Card-Level Indicators

Card-Level Indicators	Description
Red FAIL LED	The red FAIL LED indicates that the card's processor is not ready. Replace the card if the red FAIL LED persists.
Green ACT LED	The green ACT LED indicates that the card is carrying traffic or is traffic-ready.
Amber SF LED	The amber SF LED indicates a signal failure or condition such as LOS, LOF, AIS-L, or high BERs on the card's port. The amber SF LED is also on if the transmit and receive fibers are incorrectly connected. If the fibers are properly connected, the light turns off.

4.1.8.2 OC48 IR 1310 Port-Level Indicators

You can find the status of the OC48 IR 1310 card port using the LCD screen on the ONS 15454 fan-tray assembly. Use the LCD to view the status of any port or card slot; the screen displays the number and severity of alarms for a given port or slot.



Warning

Invisible laser radiation may be emitted from the end of the unterminated fiber cable or connector. Do not stare into the beam or view directly with optical instruments. Viewing the laser output with certain optical instruments (for example, eye loupes, magnifiers, and microscopes) within a distance of 100 mm may pose an eye hazard. Use of controls or adjustments or performance of procedures other than those specified may result in hazardous radiation exposure.

4.1.8.3 OC48 IR 1310 Card Specifications

The OC48 IR 1310 card has the following specifications:

- Line
 - Bit rate: 2.49 Gbps
 - Code: Scrambled NRZ
 - Fiber: 1310-nm single-mode
 - Loopback modes: Terminal and facility
 - Connectors: SC
 - Compliance: Telcordia GR-253-CORE
- Transmitter
 - Maximum transmitter output power: 0 dBm
 - Minimum transmitter output power: -5 dBm
 - Center wavelength: 1280 to 1350 nm

- Nominal wavelength: 1310 nm
- Transmitter: Uncooled direct modulated DFB
- Receiver
 - Maximum receiver level: 0 dBm
 - Minimum receiver level: -18 dBm
 - Receiver: InGaAs InP photodetector
 - Link loss budget: 13 dB minimum
 - Receiver input wavelength range: 1280 to 1350 nm
- Environmental
 - Operating temperature:
 - C-Temp (15454-OC481IR1310): -5 to +55 degrees Celsius (+23 to +131 degrees Fahrenheit)
 - Operating humidity: 5 to 95%, noncondensing
 - Power consumption: 32.20 W, 0.67 A, 109.94 BTU/hr
- Dimensions
 - Height: 12.650 in. (321.3 mm)
 - Width: 0.716 in. (18.2 mm)
 - Depth: 9.000 in. (228.6 mm)
 - Weight not including clam shell: 1.8 lb (0.8 kg)
- Compliance
 - For compliance information, refer to the *Cisco Optical Transport Products Safety and Compliance Information*.

4.1.9 OC48 LR 1550 Card

The OC48 LR 1550 card provides one long-range, SONET OC-48 port per card, compliant with Telcordia GR-253-CORE. Each port operates at 2.49 Gbps over a single-mode fiber span. The card supports VT, nonconcatenated or concatenated payloads at STS-1, STS-3c, STS-6c, STS-12c, or STS-48c signal levels. [Figure 4-9](#) shows the OC48 LR 1550 faceplate and a block diagram of the card.

Figure 4-9 OC48 LR 1550 Faceplate and Block Diagram

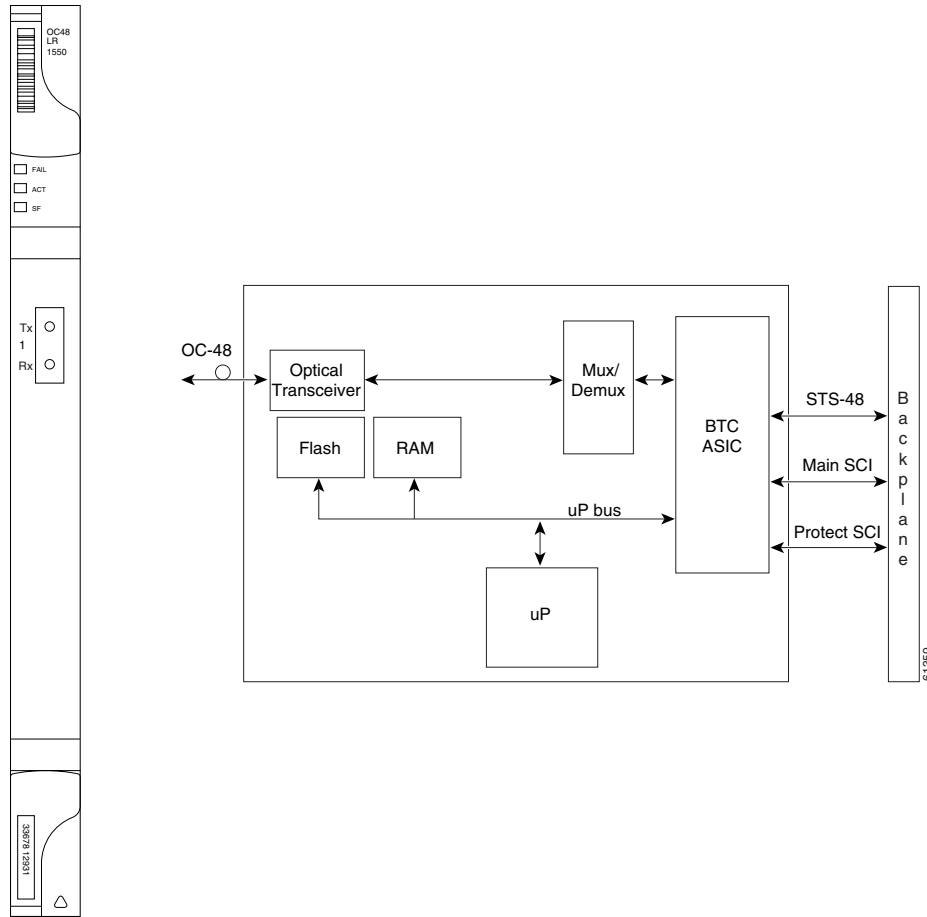

You can install OC48 LR 1550 cards in Slots 5, 6, 12, and 13 and provision the card as a drop or span card in a two-fiber or four-fiber BLSR, path protection, or ADM (linear) configuration.

The OC48 LR 1550 port features a 1550-nm laser and contains a transmit and receive connector (labeled) on the card faceplate. The card uses SC connectors, and it supports 1+1 unidirectional and bidirectional protection switching.

The OC48 LR 1550 detects LOS, LOF, LOP, AIS-L, and RDI-L conditions. The card also counts section and line BIP errors.

4.1.9.1 OC48 LR 1550 Card-Level Indicators

Table 4-9 describes the three card-level LEDs on the OC48 LR 1550 card.

Table 4-9 OC48 LR 1550 Card-Level Indicators

Card-Level Indicators	Description
Red FAIL LED	The red FAIL LED indicates that the card’s processor is not ready. Replace the card if the red FAIL LED persists.

Table 4-9 OC48 LR 1550 Card-Level Indicators (continued)

Card-Level Indicators	Description
Green ACT LED	The green ACT LED indicates that the card is carrying traffic or is traffic-ready.
Amber SF LED	The amber SF LED indicates a signal failure or condition such as LOS, LOF, or high BERs on the card's port. The amber SF LED is also on if the transmit and receive fibers are incorrectly connected. If the fibers are properly connected, the light turns off.

4.1.9.2 OC48 LR 1550 Port-Level Indicators

You can find the status of the OC48 LR 1550 card port using the LCD screen on the ONS 15454 fan-tray assembly. Use the LCD to view the status of any port or card slot; the screen displays the number and severity of alarms for a given port or slot.



Warning

Invisible laser radiation may be emitted from the end of the unterminated fiber cable or connector. Do not stare into the beam or view directly with optical instruments. Viewing the laser output with certain optical instruments (for example, eye loupes, magnifiers, and microscopes) within a distance of 100 mm may pose an eye hazard. Use of controls or adjustments or performance of procedures other than those specified may result in hazardous radiation exposure.

4.1.9.3 OC48 LR 1550 Card Specifications

The OC48 LR 1550 card has the following specifications:

- Line
 - Bit rate: 2.49 Gbps
 - Code: Scrambled NRZ
 - Fiber: 1550-nm single-mode
 - Loopback modes: Terminal and facility
 - Connectors: SC
 - Compliance: Telcordia GR-253-CORE
- Transmitter
 - Maximum transmitter output power: +3 dBm
 - Minimum transmitter output power: –2 dBm
 - Center wavelength: 1520 to 1580 nm
 - Nominal wavelength: 1550 nm
 - Transmitter: DFB laser
- Receiver
 - Maximum receiver level: –8 dBm
 - Minimum receiver level: –28 dBm
 - Receiver: InGaAs avalanche photo diode (APD) photodetector
 - Link loss budget: 26 dB minimum, with 1 dB dispersion penalty

- Receiver input wavelength range: 1520 to 1580 nm
- Environmental
 - Operating temperature:
 - C-Temp (15454-OC481LR1550): -5 to +55 degrees Celsius (+23 to +131 degrees Fahrenheit)
 - Operating humidity: 5 to 95%, noncondensing
 - Power consumption: 26.80 W, 0.56 A, 91.50 BTU/hr
- Dimensions
 - Height: 12.650 in. (321.3 mm)
 - Width: 0.716 in. (18.2 mm)
 - Depth: 9.000 in. (228.6 mm)
 - Weight not including clam shell: 1.8 lb (0.8 kg)
- Compliance
 - For compliance information, refer to the *Cisco Optical Transport Products Safety and Compliance Information*.

4.1.10 OC48 IR/STM16 SH AS 1310 Card

The OC48 IR/STM16 SH AS 1310 card provides one intermediate-range SONET/SDH OC-48 port compliant with ITU-T G.707, ITU-T G.957, and Telcordia GR-253-CORE. The port operates at 2.49 Gbps over a single-mode fiber span. The card supports VT and nonconcatenated or concatenated payloads at STS-1, STS-3c, STS-6c, STS-12c, or STS-48c signal levels. [Figure 4-10](#) shows the OC48 IR/STM16 SH AS 1310 faceplate and a block diagram of the card.

Figure 4-10 OC48 IR/STM16 SH AS 1310 Faceplate and Block Diagram

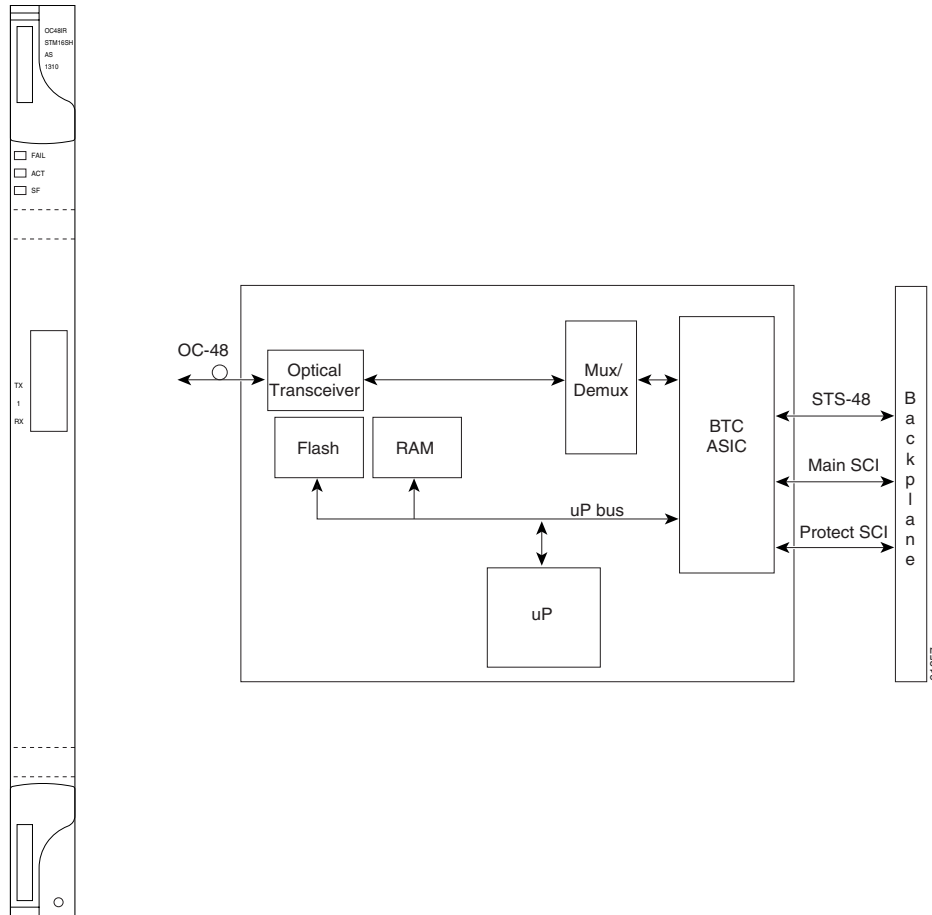

You can install the OC48 IR/STM16 SH AS 1310 card in Slots 1 to 6 and 12 to 17 and provision the card as a drop or span card in a two-fiber or four-fiber BLSR, path protection, or ADM (linear) configuration.

The OC-48 port features a 1310-nm laser and contains a transmit and receive connector (labeled) on the card faceplate. The OC48 IR/STM16 SH AS 1310 uses SC connectors. The card supports 1+1 unidirectional and bidirectional protection switching.

The OC48 IR/STM16 SH AS 1310 detects LOS, LOF, LOP, AIS-L, and RDI-L conditions. The card also counts section and line BIP errors.

4.1.10.1 OC48 IR/STM16 SH AS 1310 Card-Level Indicators

Table 4-10 lists the three card-level LEDs on the OC48 IR/STM16 SH AS 1310 card.

Table 4-10 OC48 IR/STM16 SH AS 1310 Card-Level Indicators

Card-Level Indicators	Description
Red FAIL LED	The red FAIL LED indicates that the card's processor is not ready. Replace the card if the red FAIL LED persists.

Table 4-10 OC48 IR/STM16 SH AS 1310 Card-Level Indicators (continued)

Card-Level Indicators	Description
Green ACT LED	The green ACT LED indicates that the card is carrying traffic or is traffic-ready.
Amber SF LED	The amber SF LED indicates a signal failure or condition such as LOS, LOF, AIS-L, or high BERs on the card's port. The amber SF LED is also on if the transmit and receive fibers are incorrectly connected. If the fibers are properly connected, the light turns off.

4.1.10.2 OC48 IR/STM16 SH AS 1310 Port-Level Indicators

You can find the status of the OC48 IR/STM16 SH AS 1310 card port using the LCD screen on the ONS 15454 fan-tray assembly. Use the LCD to view the status of any port or card slot; the screen displays the number and severity of alarms for a given port or slot.



Warning

Invisible laser radiation may be emitted from the end of the unterminated fiber cable or connector. Do not stare into the beam or view directly with optical instruments. Viewing the laser output with certain optical instruments (for example, eye loupes, magnifiers, and microscopes) within a distance of 100 mm may pose an eye hazard. Use of controls or adjustments or performance of procedures other than those specified may result in hazardous radiation exposure.

4.1.10.3 OC48 IR/STM16 SH AS 1310 Compatibility

Refer to the “[Optical Card Software Release Compatibility](#)” table (Table 2-6 on page 2-4) and the “[Optical Card Cross-Connect Compatibility](#)” table (Table 2-7 on page 2-5) for information on optical card compatibility.

4.1.10.4 OC48 IR/STM16 SH AS 1310 Card Specifications

The OC48 IR/STM16 SH AS 1310 card has the following specifications:

- Line
 - Bit rate: 2.49 Gbps
 - Code: Scrambled NRZ
 - Fiber: 1310-nm single-mode
 - Loopback modes: Terminal and facility
 - Connectors: SC
 - Compliance: Telcordia GR-253-CORE, ITU-T G.707, ITU-T G.957
- Transmitter
 - Maximum transmitter output power: 0 dBm
 - Minimum transmitter output power: –5 dBm
 - Center wavelength: 1280 to 1350 nm
 - Nominal wavelength: 1310 nm
 - Transmitter: DFB laser

- Dispersion tolerance: 96 ps/nm
- Receiver
 - Maximum receiver level: 0 dBm
 - Minimum receiver level: -18 dBm
 - Receiver: InGaAs InP photodetector
 - Link loss budget: 13 dB minimum
 - Receiver input wavelength range: 1280 to 1350 nm
 - Jitter tolerance: Telcordia GR-253/ITU-T G.823 compliant
- Environmental
 - Operating temperature:
C-Temp (15454-OC481IR1310A): -5 to +55 degrees Celsius (+23 to +131 degrees Fahrenheit)
 - Operating humidity: 5 to 95%, noncondensing
 - Power consumption: 37.20 W, 0.77 A, 127.01 BTU/hr
- Dimensions
 - Height: 12.650 in. (321.3 mm)
 - Width: 0.716 in. (18.2 mm)
 - Depth: 9.000 in. (228.6 mm)
 - Weight not including clam shell: 2.2 lb (0.9 kg)
- Compliance
 - For compliance information, refer to the *Cisco Optical Transport Products Safety and Compliance Information*.

4.1.11 OC48 LR/STM16 LH AS 1550 Card

The OC48 LR/STM16 LH AS 1550 card provides one long-range SONET/SDH OC-48 port compliant with ITU-T G.707, ITU-T G.957, and Telcordia GR-253-CORE. Each port operates at 2.49 Gbps over a single-mode fiber span. The card supports VT and nonconcatenated or concatenated payloads at STS-1, STS-3c, STS-6c, STS-12c, or STS-48c signal levels. [Figure 4-11](#) shows a block diagram and the faceplate of the OC48 LR/STM16 LH AS 1550 card.

Figure 4-11 OC48 LR/STM16 LH AS 1550 Faceplate and Block Diagram

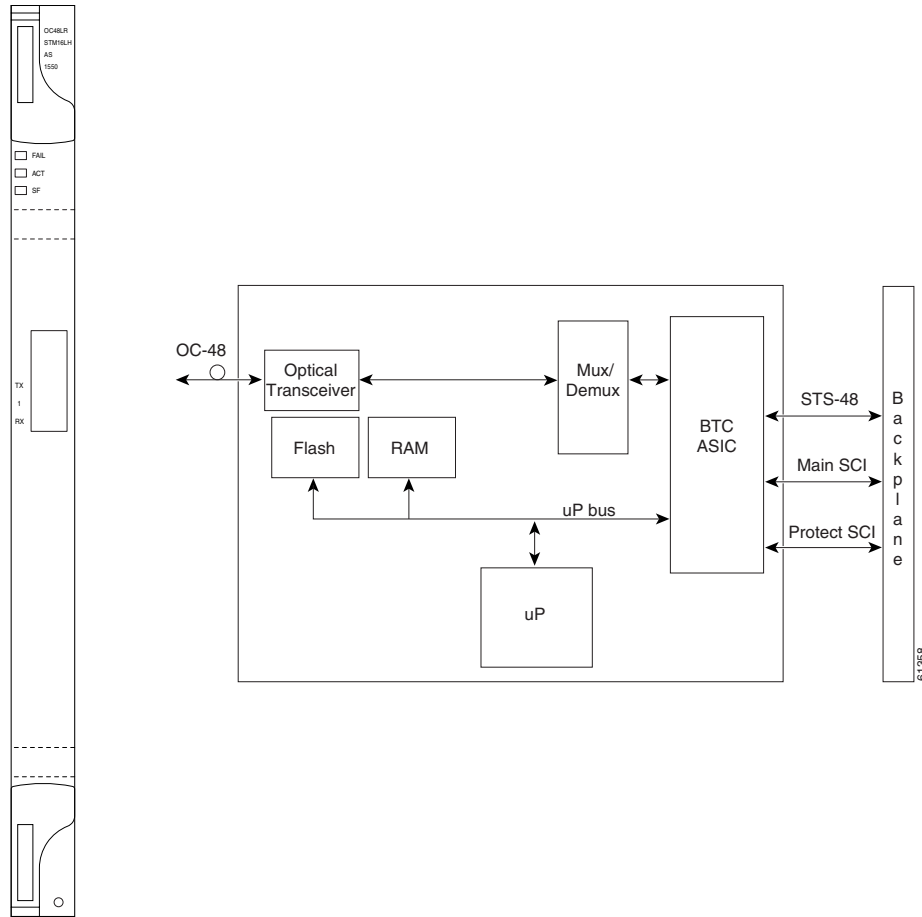

You can install OC48 LR/STM16 LH AS 1550 cards in Slots 1 to 6 and 12 to 17 and provision the card as a drop or span card in a two-fiber or four-fiber BLSR, path protection, or ADM (linear) configuration.

The OC48 LR/STM16 LH AS 1550 port features a 1550-nm laser and contains a transmit and receive connector (labeled) on the card faceplate. The card uses SC connectors, and it supports 1+1 unidirectional and bidirectional protection switching.

The OC48 LR/STM16 LH AS 1550 detects LOS, LOF, LOP, AIS-L, and RDI-L conditions. The card also counts section and line BIP errors.

4.1.11.1 OC48 LR/STM16 LH AS 1550 Card-Level Indicators

Table 4-11 describes the three card-level LEDs on the OC48 LR/STM16 LH AS 1550 card.

Table 4-11 OC48 LR/STM16 LH AS 1550 Card-Level Indicators

Card-Level Indicators	Description
Red FAIL LED	The red FAIL LED indicates that the card’s processor is not ready. Replace the card if the red FAIL LED persists.

Table 4-11 OC48 LR/STM16 LH AS 1550 Card-Level Indicators (continued)

Card-Level Indicators	Description
Green ACT LED	The green ACT LED indicates that the card is carrying traffic or is traffic-ready.
Amber SF LED	The amber SF LED indicates a signal failure or condition such as LOS, LOF, or high BERs on the card's port. The amber SF LED is also on if the transmit and receive fibers are incorrectly connected. If the fibers are properly connected, the light turns off.

4.1.11.2 OC48 LR/STM16 LH AS 1550 Port-Level Indicators

You can find the status of the OC48 LR/STM16 LH AS 1550 card port using the LCD screen on the ONS 15454 fan-tray assembly. Use the LCD to view the status of any port or card slot; the screen displays the number and severity of alarms for a given port or slot.



Warning

Invisible laser radiation may be emitted from the end of the unterminated fiber cable or connector. Do not stare into the beam or view directly with optical instruments. Viewing the laser output with certain optical instruments (for example, eye loupes, magnifiers, and microscopes) within a distance of 100 mm may pose an eye hazard. Use of controls or adjustments or performance of procedures other than those specified may result in hazardous radiation exposure.

4.1.11.3 OC48 LR/STM16 LH AS 1550 Compatibility

Refer to the “[Optical Card Software Release Compatibility](#)” table (Table 2-6 on page 2-4) and the “[Optical Card Cross-Connect Compatibility](#)” table (Table 2-7 on page 2-5) for information on optical card compatibility.

4.1.11.4 OC48 LR/STM16 LH AS 1550 Card Specifications

The OC48 LR/STM16 LH AS 1550 card has the following specifications:

- Line
 - Bit rate: 2.49 Gbps
 - Code: Scrambled NRZ
 - Fiber: 1550-nm single-mode
 - Loopback modes: Terminal and facility
 - Connectors: SC
 - Compliance: Telcordia GR-253-CORE, ITU-T G.707, ITU-T G.957
- Transmitter
 - Maximum transmitter output power: +3 dBm
 - Minimum transmitter output power: –2 dBm
 - Center wavelength: 1520 to 1580 nm
 - Nominal wavelength: 1550 nm
 - Transmitter: DFB laser

- Dispersion ratio: 3600 ps/nm
- Receiver
 - Maximum receiver level: -8 dBm
 - Minimum receiver level: -28 dBm
 - Receiver: InGaAs APD photodetector
 - Link loss budget: 26 dB minimum, with 1 dB dispersion penalty
 - Receiver input wavelength range: 1520 to 1580 nm
 - Jitter tolerance: Telcordia GR-253/ITU-T G.823 compliant
- Environmental
 - Operating temperature:
 - C-Temp (15454-OC481LR1550A): -5 to +55 degrees Celsius (+23 to +131 degrees Fahrenheit)
 - Operating humidity: 5 to 95%, noncondensing
 - Power consumption: 37.20 W, 0.77 A, 127.01 BTU/hr
- Dimensions
 - Height: 12.650 in. (321.3 mm)
 - Width: 0.716 in. (18.2 mm)
 - Depth: 9.000 in. (228.6 mm)
 - Weight not including clam shell: 2.2 lb (0.9 kg)
- Compliance
 - For compliance information, refer to the *Cisco Optical Transport Products Safety and Compliance Information*.

4.1.12 OC48 ELR/STM16 EH 100 GHz Cards

Thirty-seven distinct OC48 ELR/STM16 EH 100 GHz cards provide the ONS 15454 DWDM channel plan. Each OC48 ELR/STM16 EH 100 GHz card has one SONET OC-48/SDH STM-16 port that complies with Telcordia GR-253-CORE, ITU-T G.692, and ITU-T G.958.

The port operates at 2.49 Gbps over a single-mode fiber span. The card carries VT, concatenated, and nonconcatenated payloads at STS-1, STS-3c, STS-6c, STS-12c, or STS-48c signal levels. [Figure 4-12](#) shows the OC48 ELR/STM16 EH 100 GHz faceplate and a block diagram of the card.

Figure 4-12 OC48 ELR/STM16 EH 100 GHz Faceplate and Block Diagram

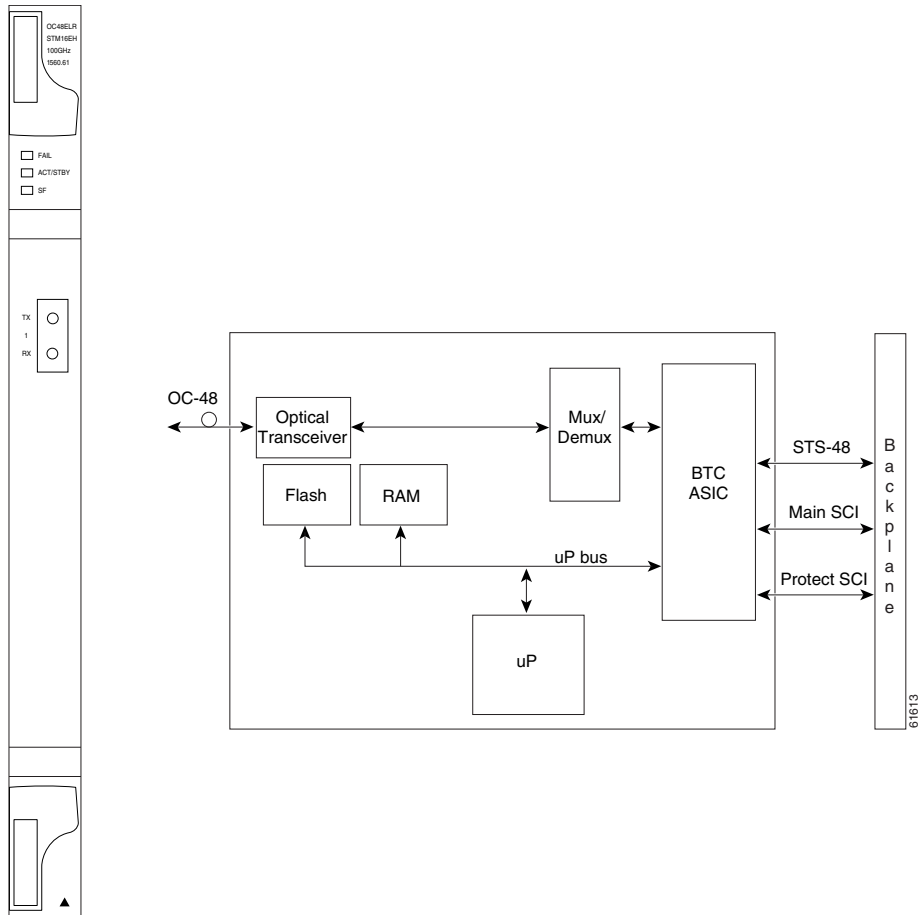

Nineteen of the cards operate in the blue band with spacing of 100 GHz on the ITU grid (1528.77 nm, 1530.33 nm, 1531.12 nm, 1531.90 nm, 1532.68 nm, 1533.47 nm, 1534.25 nm, 1535.04 nm, 1535.82 nm, 1536.61 nm, 1538.19 nm, 1538.98 nm, 1539.77 nm, 1540.56 nm, 1541.35 nm, 1542.14 nm, 1542.94 nm, 1543.73 nm, and 1544.53 nm). ITU spacing conforms to ITU-T G.692 and Telcordia GR-2918-CORE, Issue 2.

The other 18 cards operate in the red band with spacing of 100 GHz on the ITU grid (1546.12 nm, 1546.92 nm, 1547.72 nm, 1548.51 nm, 1549.32 nm, 1550.12 nm, 1550.92 nm, 1551.72 nm, 1552.52 nm, 1554.13 nm, 1554.94 nm, 1555.75 nm, 1556.55 nm, 1557.36 nm, 1558.17 nm, 1558.98 nm, 1559.79 nm, and 1560.61 nm). These cards are also designed to interoperate with the Cisco ONS 15216 DWDM solution.

You can install the OC48 ELR/STM16 EH 100 GHz cards in Slots 5, 6, 12, and 13, and provision the card as a drop or span card in a two-fiber or four-fiber BLSR, path protection, or ADM (linear) configuration. Each OC48 ELR/STM16 EH 100 GHz card uses extended long-reach optics operating individually within the ITU-T 100-GHz grid. The OC-48 DWDM cards are intended to be used in applications with long unregenerated spans of up to 300 km (186 miles) (with mid-span amplification). These transmission distances are achieved through the use of inexpensive optical amplifiers (flat gain amplifiers) such as Cisco ONS 15216 erbium-doped fiber amplifiers (EDFAs).

Maximum system reach in filterless applications is 26 dB without the use of optical amplifiers or regenerators. However, system reach also depends on the condition of the facilities, number of splices and connectors, and other performance-affecting factors. When used in combination with ONS 15216

100-GHz filters, the link budget is reduced by the insertion loss of the filters plus an additional 2-dB power penalty. The wavelength stability of the OC48 ELR/STM16 EH 100 GHz cards is ± 0.12 nm for the life of the product and over the full range of operating temperatures. Each interface contains a transmitter and receiver.

The OC48 ELR/STM16 EH 100 GHz cards detect LOS, LOF, LOP, and AIS-L conditions. The cards also count section and line BIP errors.

4.1.12.1 OC48 ELR 100 GHz Card-Level Indicators

Table 4-12 lists the three card-level LEDs on the OC48 ELR/STM16 EH 100 GHz cards.

Table 4-12 OC48 ELR/STM16 EH 100 GHz Card-Level Indicators

Card-Level Indicators	Description
Red FAIL LED	The red FAIL LED indicates that the card's processor is not ready. Replace the card if the red FAIL LED persists.
Green ACT LED	The green ACT LED indicates that the card is carrying traffic or is traffic-ready.
Amber SF LED	The amber SF LED indicates a signal failure or condition such as LOS, LOF, or high BERs on the card's port. The amber SF LED is also on if the transmit and receive fibers are incorrectly connected. If the fibers are properly connected, the light turns off.

4.1.12.2 OC48 ELR 100 GHz Port-Level Indicators

You can find the status of the OC48 ELR/STM16 EH 100 GHz card ports using the LCD screen on the ONS 15454 fan-tray assembly. Use the LCD to quickly view the status of any port or card slot; the screen displays the number and severity of alarms for a given port or slot.



Warning

Invisible laser radiation may be emitted from the end of the unterminated fiber cable or connector. Do not stare into the beam or view directly with optical instruments. Viewing the laser output with certain optical instruments (for example, eye loupes, magnifiers, and microscopes) within a distance of 100 mm may pose an eye hazard. Use of controls or adjustments or performance of procedures other than those specified may result in hazardous radiation exposure.

4.1.12.3 OC48 ELR 100 GHz Card Specifications

The OC48 ELR 100 GHz card has the following specifications:

- Line
 - Bit rate: 2.49 Gbps
 - Code: Scrambled NRZ
 - Fiber: 1550-nm single-mode
 - Loopback modes: Terminal and facility
 - Connectors: SC
 - Compliance: Telcordia GR-253-CORE, ITU-T G.692, ITU-T G.958

- Transmitter
 - Maximum transmitter output power: 0 dBm
 - Minimum transmitter output power: –2 dBm
 - Center wavelength: ± 12 nm
 - Transmitter: Electro-absorption laser
 - Dispersion tolerance: 5400 ps/nm
- Receiver
 - Maximum receiver level: –9 dBm
 - Minimum receiver level: –27 dBm at $1E-12$ BER
 - Receiver: InGaAs APD photodetector
 - Link loss budget: 25 dB minimum at $1E-12$ BER (not including the power dispersion penalty)
 - Dispersion Penalty: 2 dB for a dispersion of up to 5400 ps/nm
 - Receiver input wavelength range: 1520 to 1580 nm
 - Jitter tolerance: Telcordia GR-253/ITU-T G.823 compliant
- Environmental
 - Operating temperature: C-Temp: –5 to +55 degrees Celsius (+23 to +131 degrees Fahrenheit)
 - Operating humidity: 5 to 95%, noncondensing
 - Power consumption: 31.20 W, 0.65 A, 106.53 BTU/hr
- Dimensions
 - Height: 12.650 in. (321.3 mm)
 - Width: 0.716 in. (18.2 mm)
 - Depth: 9.000 in. (228.6 mm)
 - Weight not including clam shell: 2.4 lb (1.1 kg)
- Compliance
 - For compliance information, refer to the *Cisco Optical Transport Products Safety and Compliance Information*.

4.1.13 OC48 ELR 200 GHz Cards

Eighteen distinct OC48 ELR 200 GHz cards provide the ONS 15454 DWDM channel plan. Each OC48 ELR 200 GHz card provides one SONET OC-48 port that is compliant with Telcordia GR-253-CORE. The port operates at 2.49 Gbps over a single-mode fiber span. The card carries VT, concatenated, and nonconcatenated payloads at STS-1, STS-3c, STS-6c, STS-12c, or STS-48c signal levels. [Figure 4-13](#) shows the OC48 ELR 200 GHz faceplate and a block diagram of the card.

Figure 4-13 OC48 ELR 200 GHz Faceplate and Block Diagram

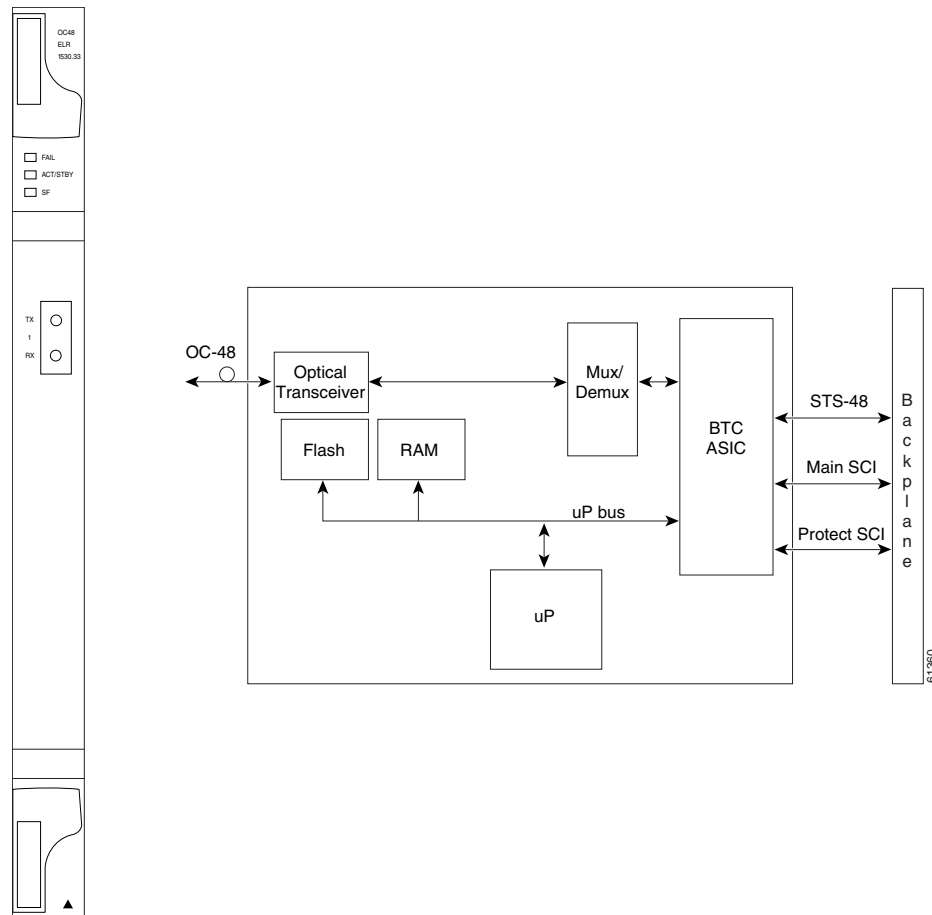

Nine of the cards operate in the blue band with spacing of 200 GHz on the ITU grid (1530.33 nm, 1531.90 nm, 1533.47 nm, 1535.04 nm, 1536.61 nm, 1538.19 nm, 1539.77 nm, 1541.35 nm, and 1542.94 nm).

The other nine cards operate in the red band with spacing of 200 GHz on the ITU grid (1547.72 nm, 1549.32 nm, 1550.92 nm, 1552.52 nm, 1554.13 nm, 1555.75 nm, 1557.36 nm, 1558.98 nm, and 1560.61 nm). These cards are also designed to interoperate with the Cisco ONS 15216 DWDM solution.

You can install the OC48 ELR 200 GHz cards in Slots 5, 6, 12, and 13, and provision the card as a drop or span card in a two-fiber or four-fiber BLSR, path protection, or ADM (linear) configuration. Each OC48 ELR 200 GHz card uses extended long-reach optics operating individually within the ITU-T 200-GHz grid. The OC48 ELR 200 GHz cards are intended to be used in applications with long unregenerated spans of up to 200 km (124 miles) (with mid-span amplification). These transmission distances are achieved through the use of inexpensive optical amplifiers (flat gain amplifiers) such as EDFAs. Using collocated amplification, distances up to 200 km (124 miles) can be achieved for a single channel, 160 km (99 miles) for 8 channels.

Maximum system reach in filterless applications is 24 dB or approximately 80 km (50 miles) without the use of optical amplifiers or regenerators. However, system reach also depends on the condition of the facilities, number of splices and connectors or other performance-affecting factors. The OC48 ELR DWDM cards feature wavelength stability of ± 0.25 nm. Each interface contains a transmitter and receiver.

The OC48 ELR 200 GHz cards are the first in a family of cards meant to support extended long-reach applications in conjunction with optical amplification. Using electro-absorption technology, the OC48 DWDM cards provide a solution at the lower extended long-reach distances.

The OC48 ELR 200 GHz interface features a 1550-nm laser and contains a transmit and receive connector (labeled) on the card faceplate. The card uses SC connectors and supports 1+1 unidirectional and bidirectional protection switching.

The OC48 ELR 200 GHz cards detect LOS, LOF, LOP, AIS-L, and RDI-L conditions. The cards also count section and line BIP errors. To enable APS, the OC48 ELR 200 GHz cards extract the K1 and K2 bytes from the SONET overhead. The DCC bytes are forwarded to the TCC2 card; the TCC2 terminates the DCC/GCC.

4.1.13.1 OC48 ELR 200 GHz Card-Level Indicators

Table 4-13 describes the three card-level LEDs on the OC48 ELR 200 GHz cards.

Table 4-13 OC48 ELR 200 GHz Card-Level Indicators

Card-Level Indicators	Description
Red FAIL LED	The red FAIL LED indicates that the card's processor is not ready. Replace the card if the red FAIL LED persists.
Green ACT LED	The green ACT LED indicates that the card is carrying traffic or is traffic-ready.
Amber SF LED	The amber SF LED indicates a signal failure or condition such as LOS, LOF, or high BERs on the card's port. The amber SF LED is also on if the transmit and receive fibers are incorrectly connected. If the fibers are properly connected, the light turns off.

4.1.13.2 OC48 ELR 200 GHz Port-Level Indicators

You can find the status of the OC48 ELR 200 GHz card ports using the LCD screen on the ONS 15454 fan-tray assembly. Use the LCD to quickly view the status of any port or card slot; the screen displays the number and severity of alarms for a given port or slot.



Warning

Invisible laser radiation may be emitted from the end of the unterminated fiber cable or connector. Do not stare into the beam or view directly with optical instruments. Viewing the laser output with certain optical instruments (for example, eye loupes, magnifiers, and microscopes) within a distance of 100 mm may pose an eye hazard. Use of controls or adjustments or performance of procedures other than those specified may result in hazardous radiation exposure.

4.1.13.3 OC48 ELR 200 GHz Card Specifications

The OC48 ELR 200 GHz card has the following specifications:

- Line
 - Bit rate: 2.49 Gbps
 - Code: Scrambled NRZ
 - Fiber: 1550-nm single-mode

- Loopback modes: Terminal and facility
- Connectors: SC
- Compliance: Telcordia GR-253-CORE, ITU-T G692, ITU-T G958
- Transmitter
 - Maximum transmitter output power: 0 dBm
 - Minimum transmitter output power: –2 dBm
 - Center wavelength: ± 0.25 nm
 - Transmitter: Electro-absorption laser
 - Dispersion tolerance: 3600 ps/nm
- Receiver
 - Maximum receiver level: –8 dBm
 - Minimum receiver level: –28 dBm
 - Receiver: InGaAs APD photodetector
 - Link loss budget: 26 dB minimum, with 1 dB dispersion penalty
 - Receiver input wavelength range: 1520 to 1580 nm
 - Jitter tolerance: Telcordia GR-253/ITU-T G.823 compliant
- Environmental
 - Operating temperature:
 - C-Temp: –5 to +55 degrees Celsius (+23 to +131 degrees Fahrenheit)
 - Operating humidity: 5 to 95%, noncondensing
 - Power consumption: 31.20 W, 0.65 A, 106.53 BTU/hr
- Dimensions
 - Height: 12.650 in. (321.3 mm)
 - Width: 0.716 in. (18.2 mm)
 - Depth: 9.000 in. (228.6 mm)
 - Weight not including clam shell: 2.9 lb (1.3 kg)
- Compliance
 - For compliance information, refer to the *Cisco Optical Transport Products Safety and Compliance Information*.

4.1.14 OC192 SR/STM64 IO 1310 Card

The OC192 SR/STM64 IO 1310 card provides one intra-office haul SONET/SDH OC-192 port in the 1310-nm wavelength range, compliant with ITU-T G.707, ITU-T G.691, ITU-T G.957, and Telcordia GR-253-CORE. The port operates at 9.95328 Gbps over unamplified distances up to 2 km (1.24 miles). The card supports VT and nonconcatenated or concatenated payloads. [Figure 4-14](#) shows the OC192 SR/STM64 IO 1310 faceplate.

Figure 4-14 OC192 SR/STM64 IO 1310 Faceplate

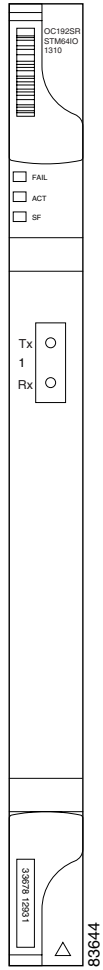
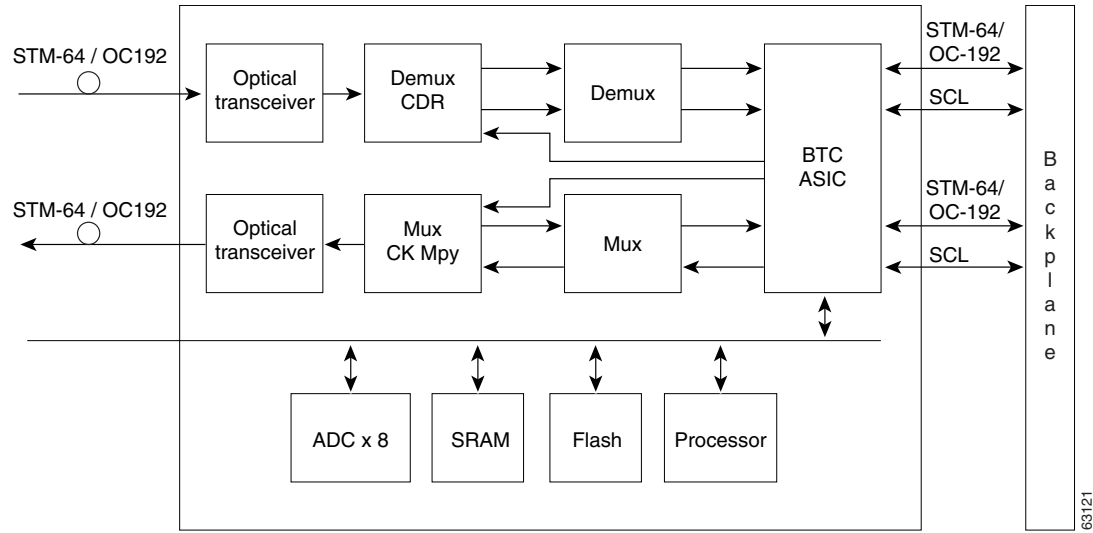

Figure 4-15 shows a block diagram of the OC192 SR/STM64 IO 1310 card.

Figure 4-15 OC192 SR/STM64 IO 1310 Block Diagram



You can install OC192 SR/STM64 IO 1310 cards in Slot 5, 6, 12, or 13. You can provision this card as part of an BLSR, a path protection, a linear configuration, or as a regenerator for longer span reaches.

The OC192 SR/STM64 IO 1310 port features a 1310-nm laser and contains a transmit and receive connector (labeled) on the card faceplate. The card uses a dual SC connector for optical cable termination. The card supports 1+1 unidirectional and bidirectional facility protection. It also supports 1:1 protection in four-fiber bidirectional line switched ring applications where both span switching and ring switching might occur.

The OC192 SR/STM64 IO 1310 card detects SF, LOS, or LOF conditions on the optical facility. Refer to the *Cisco ONS 15454 Troubleshooting Guide* for a description of these conditions. The card also counts section and line BIP errors from B1 and B2 byte registers in the section and line overhead.

4.1.14.1 OC192 SR/STM64 IO 1310 Card-Level Indicators

Table 4-14 describes the three card-level LEDs on the OC192 SR/STM64 IO 1310 card.

Table 4-14 OC192 SR/STM64 IO 1310 Card-Level Indicators

Card-Level LED	Description
Red FAIL LED	The red FAIL LED indicates that the card's processor is not ready. This LED is on during reset. The FAIL LED flashes during the boot process. Replace the card if the red FAIL LED persists.
ACT/STBY LED Green (Active) Amber (Standby)	If the ACT/STBY LED is green, the card is operational and ready to carry traffic. If the ACT/STBY LED is amber, the card is operational and in standby (protect) mode.
Amber SF LED	The amber SF LED indicates a signal failure or condition such as LOS, LOF, or high BERs on one or more of the card's ports. The amber SF LED is also on if the transmit and receive fibers are incorrectly connected. If the fibers are properly connected and the link is working, the light turns off.

4.1.14.2 OC192 SR/STM64 IO 1310 Port-Level Indicators

You can find the status of the OC192 SR/STM64 IO 1310 card ports using the LCD screen on the ONS 15454 fan-tray assembly. Use the LCD to view the status of any port or card slot; the screen displays the number and severity of alarms for a given port or slot. Refer to the *Cisco ONS 15454 Troubleshooting Guide* for a complete description of the alarm messages.

4.1.14.3 OC192 SR/STM64 IO 1310 Card Specifications

The OC 192 SR/STM64 IO 1310 card has the following specifications:

- Line
 - Bit rate: 9.95328 Gbps
 - Code: Scrambled NRZ
 - Fiber: 1310-nm single-mode
 - Maximum chromatic dispersion allowance: 6.6 ps/nm
 - Loopback modes: Terminal and facility
 - Connectors: SC
 - Compliance: Telcordia GR-253-CORE, ITU-T G.707, ITU-T G.957, ITU-T G.691
- Transmitter
 - Maximum transmitter output power: –1 dBm
 - Minimum transmitter output power: –6 dBm
 - Center wavelength: 1290 to 1330 nm
 - Nominal wavelength: 1310 nm
 - Transmitter: Directly modulated laser
- Receiver
 - Maximum receiver level: –1 dBm at BER $1 * 10^{exp - 12}$
 - Minimum receiver level: –11 dBm at BER $1 * 10^{exp - 12}$
 - Receiver: PIN diode
 - Link loss budget: 5 dB minimum, plus 1 dB dispersion penalty at BER = $1 * 10^{exp - 12}$ including dispersion
 - Receiver input wavelength range: 1290 to 1330 nm
 - Dispersion tolerance: 6.6 ps/nm
- Environmental
 - Operating temperature: –5 to +55 degrees Celsius (+23 to +131 degrees Fahrenheit)
 - Operating humidity: 5 to 95%, noncondensing
 - Power consumption: 47.00 W, 0.98 A at –48 V, 160.5 BTU/hr
- Dimensions
 - Height: 12.650 in. (321.3 mm)
 - Width: 0.716 in. (18.2 mm)
 - Depth: 9.000 in. (228.6 mm)

- Depth with backplane connector: 9.250 in. (235 mm)
- Weight not including clam shell: 3.1 lb (1.3 kg)
- Compliance
 - For compliance information, refer to the *Cisco Optical Transport Products Safety and Compliance Information*.

4.1.15 OC192 IR/STM64 SH 1550 Card



Warning

High-performance devices on this card can get hot during operation. To remove the card, hold it by the faceplate and bottom edge. Allow the card to cool before touching any other part of it or before placing it in an antistatic bag.



Warning

Do not reach into a vacant slot or chassis while you install or remove a module or a fan. Exposed circuitry could constitute an energy hazard.

The OC192 IR/STM64 SH 1550 card provides one intermediate reach SONET/SDH OC-192 port in the 1550-nm wavelength range, compliant with ITU-T G.707, ITU-T G.691, ITU-T G.957, and Telcordia GR-253-CORE. The port operates at 9.95328 Gbps over unamplified distances up to 40 km (25 miles) with SMF-28 fiber limited by loss and/or dispersion. The card supports VT and nonconcatenated or concatenated payloads. [Figure 4-16](#) shows the OC192 IR/STM64 SH 1550 faceplate.

Figure 4-16 OC192 IR/STM64 SH 1550 Faceplate

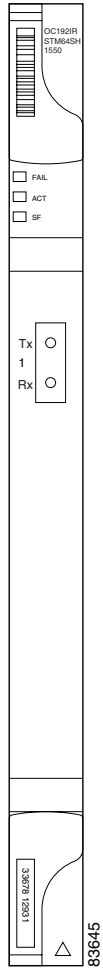
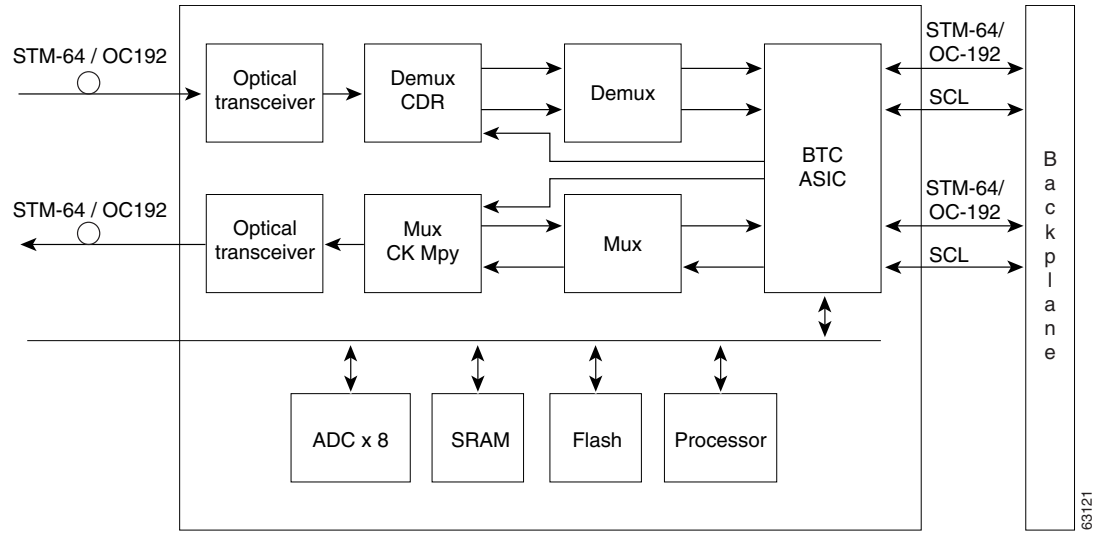

Figure 4-17 shows a block diagram of the OC192 IR/STM64 SH 1550 card.

Figure 4-17 OC192 IR/STM64 SH 1550 Block Diagram



Note

You must use a 3 to 15 dB fiber attenuator (5 dB recommended) when working with the OC192 IR/STM64 SH 1550 card in a loopback. Do not use fiber loopbacks with the OC192 IR/STM64 SH 1550 card. Using fiber loopbacks can cause irreparable damage to the card.

You can install OC192 IR/STM64 SH 1550 cards in Slot 5, 6, 12, or 13. You can provision this card as part of an BLSR, path protection, or linear configuration, or also as a regenerator for longer span reaches.

The OC192 IR/STM64 SH 1550 port features a 1550-nm laser and contains a transmit and receive connector (labeled) on the card faceplate. The card uses a dual SC connector for optical cable termination. The card supports 1+1 unidirectional and bidirectional facility protection. It also supports 1:1 protection in four-fiber bidirectional line switched ring applications where both span switching and ring switching might occur.

The OC192 IR/STM64 SH 1550 card detects SF, LOS, or LOF conditions on the optical facility. Refer to the *Cisco ONS 15454 Troubleshooting Guide* for a description of these conditions. The card also counts section and line BIP errors from B1 and B2 byte registers in the section and line overhead.

4.1.15.1 OC192 IR/STM64 SH 1550 Card-Level Indicators

Table 4-15 describes the three card-level LEDs on the OC192 IR/STM64 SH 1550 card.

Table 4-15 OC192 IR/STM64 SH 1550 Card-Level Indicators

Card-Level LED	Description
Red FAIL LED	The red FAIL LED indicates that the card's processor is not ready. This LED is on during reset. The FAIL LED flashes during the boot process. Replace the card if the red FAIL LED persists.

Table 4-15 OC192 IR/STM64 SH 1550 Card-Level Indicators (continued)

Card-Level LED	Description
ACT/STBY LED Green (Active) Amber (Standby)	If the ACTV/STBY LED is green, the card is operational and ready to carry traffic. If the ACTV/STBY LED is amber, the card is operational and in standby (protect) mode.
Amber SF LED	The amber SF LED indicates a signal failure or condition such as LOS, LOF, or high BERs on one or more of the card's ports. The amber SF LED is also on if the transmit and receive fibers are incorrectly connected. If the fibers are properly connected and the link is working, the light turns off.

4.1.15.2 OC192 IR/STM64 SH 1550 Port-Level Indicators

You can find the status of the OC192 IR/STM64 SH 1550 card ports using the LCD screen on the ONS 15454 fan-tray assembly. Use the LCD to view the status of any port or card slot; the screen displays the number and severity of alarms for a given port or slot. Refer to the *Cisco ONS 15454 Troubleshooting Guide* for a complete description of the alarm messages.

4.1.15.3 OC192 IR/STM64 SH 1550 Card Specifications

The OC192 IR/STM64 SH 1550 card has the following specifications:

- Line
 - Bit rate: 9.95328 Gbps
 - Code: Scrambled NRZ
 - Fiber: 1550-nm single-mode
 - Maximum chromatic dispersion allowance: 800 ps/nm
 - Loopback modes: Terminal and facility



Note You must use a 3 to 15 dB fiber attenuator (5 dB recommended) when working with the OC192 IR/STM64 SH 1550 card in a loopback. Do not use fiber loopbacks with the OC192 IR/STM64 SH 1550 card. Using fiber loopbacks can cause irreparable damage to the OC192 IR/STM64 SH 1550 card.

- Connectors: SC
- Compliance: Telcordia GR-253-CORE, ITU-T G.707, ITU-T G.957, ITU-T G.691
- Transmitter
 - Maximum transmitter output power: +2 dBm
 - Minimum transmitter output power: -1 dBm
 - Center wavelength: 1530 to 1565 nm
 - Nominal wavelength: 1550 nm
 - Transmitter: Cooled EA modulated laser
- Receiver
 - Maximum receiver level: -1 dBm at BER $1 * 10^{exp - 12}$

- Minimum receiver level: -14 dBm at BER $1 * 10 \text{ exp} - 12$
- Receiver: PIN diode
- Link loss budget: 13 dB minimum, plus 2 dB dispersion penalty at BER = $1 * 10 \text{ exp} - 12$ including dispersion
- Receiver input wavelength range: 1530 to 1565 nm
- Dispersion Tolerance: 800 ps/nm
- Environmental
 - Operating temperature: -5 to +55 degrees Celsius (+23 to +131 degrees Fahrenheit)
 - Operating humidity: 5 to 95%, noncondensing
 - Power consumption: 50.00 W, 1.04 A at -48 V, 170.7 BTU/hr
- Dimensions
 - Height: 12.650 in. (321.3 mm)
 - Width: 0.716 in. (18.2 mm)
 - Depth: 9.000 in. (228.6 mm)
 - Depth with backplane connector: 9.250 in. (235 mm)
 - Weight not including clam shell: 3.1 lb (1.3 kg)
- Compliance
 - For compliance information, refer to the *Cisco Optical Transport Products Safety and Compliance Information*.

4.1.16 OC192 LR/STM64 LH 1550 Card

The OC192 LR/STM64 LH 1550 card provides one long-range SONET/SDH OC-192 port compliant with ITU-T G.707, ITU-T G.691, ITU-T G.957, and Telcordia GR-253-CORE (except minimum and maximum transmit power, and minimum receive power). The card port operates at 9.96 Gbps over unamplified distances up to 80 km (50 miles) with different types of fiber such as C-SMF or dispersion compensated fiber limited by loss and/or dispersion. The card supports VT and nonconcatenated or concatenated payloads.

[Figure 4-18](#) shows the OC192 LR/STM64 LH 1550 faceplate and a block diagram of the card.

Figure 4-18 OC192 LR/STM64 LH 1550 Faceplate and Block Diagram

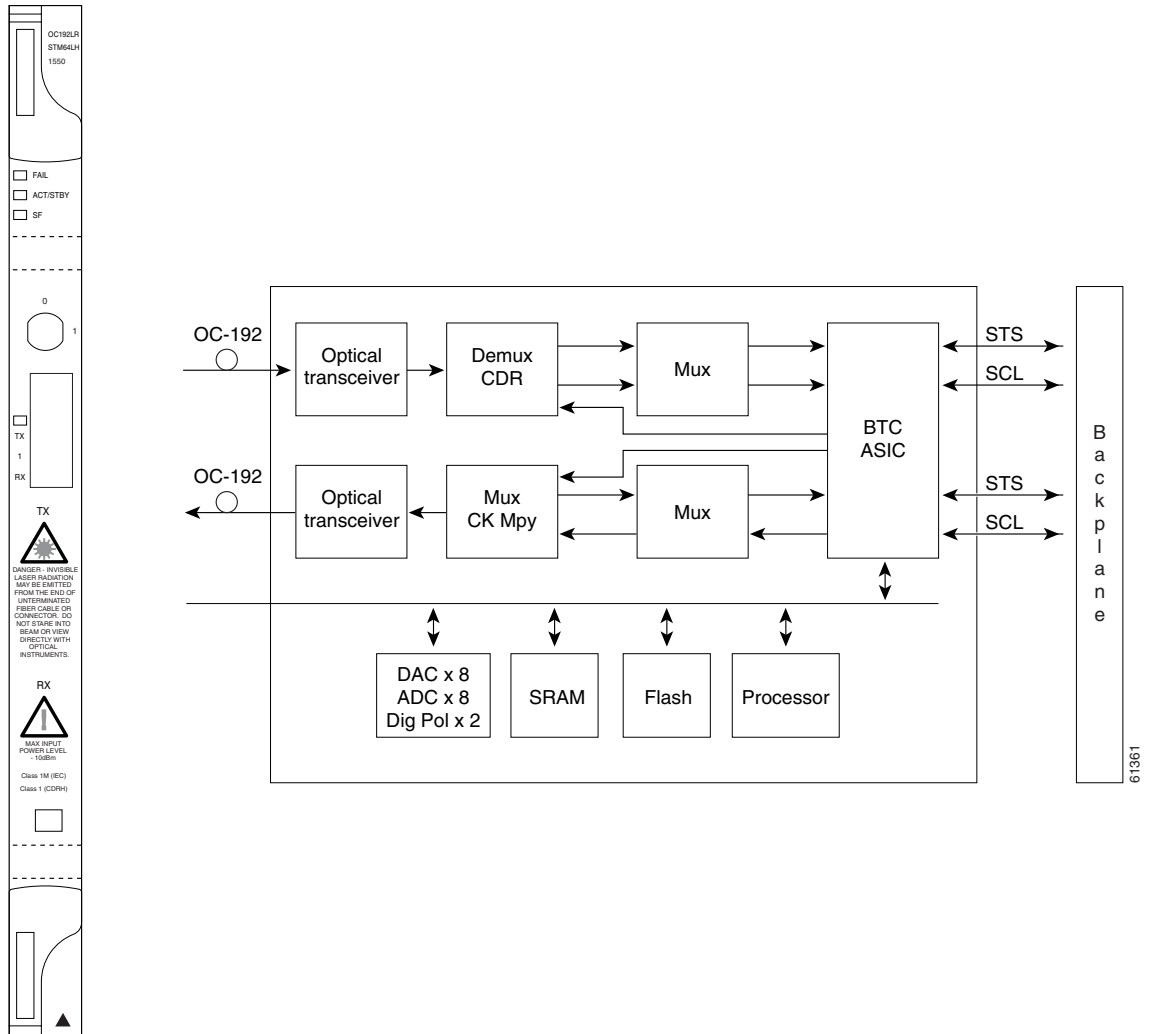
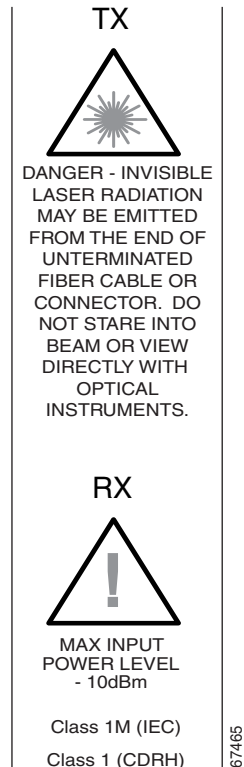

Figure 4-19 shows an enlarged view of the faceplate warning.

Figure 4-19 Enlarged Section of the OC192 LR/STM64 LH 1550 Faceplate

**Caution**

You must use a 19 to 24 dB (20 dB recommended) fiber attenuator when connecting a fiber loopback to an OC192 LR/STM64 LH 1550 card. Never connect a direct fiber loopback. Using fiber loopbacks causes irreparable damage to the card. A transmit-to-receive (Tx-to-Rx) connection that is not attenuated damages the receiver.

You can install OC192 LR/STM64 LH 1550 cards in Slots 5, 6, 12, and 13 and provision the card as a drop or span card in a two-fiber or four-fiber BLSR, path protection, or ADM (linear) configuration.

The OC-192 card port features a 1550-nm laser and contains a transmit and receive connector (labeled) on the card faceplate.

**Warning**

On the OC192 LR/STM64 LH 1550 card, the laser is on if the card is booted and the safety key is in the on position (labeled 1). The port does not have to be in service for the laser to be on. The laser is off when the safety key is off (labeled 0).

The card uses a dual SC connector for optical cable termination. The card supports 1+1 unidirectional and bidirectional facility protection. It also supports 1:1 protection in four-fiber bidirectional line switched ring applications where both span switching and ring switching might occur.

The OC192 LR/STM64 LH 1550 card detects SF, LOS, or LOF conditions on the optical facility. The card also counts section and line BIT errors from B1 and B2 byte registers in the section and line overhead.

4.1.16.1 OC192 LR/STM64 LH 1550 Card-Level Indicators

Table 4-16 describes the three card-level LEDs on the OC192 LR/STM64 LH 1550 card.

Table 4-16 OC192 LR/STM64 LH 1550 Card-Level Indicators

Card-Level Indicators	Description
Red FAIL LED	The red FAIL LED indicates that the card's processor is not ready. Replace the card if the red FAIL LED persists.
ACT/STBY LED Green (Active) Amber (Standby)	If the ACT/STBY LED is green, the card is operational and ready to carry traffic. If the ACT/STBY LED is amber, the card is operational and in standby (protect) mode.
Amber SF LED	The amber SF LED indicates a signal failure or condition such as LOS, LOF, or high BERs on the card's port. The amber SF LED is also on if the transmit and receive fibers are incorrectly connected. If the fibers are properly connected, the light turns off.

4.1.16.2 OC192 LR/STM64 LH 1550 Port-Level Indicators

You can find the status of the OC192 LR/STM64 LH 1550 card port using the LCD screen on the ONS 15454 fan-tray assembly. Use the LCD to view the status of the port or card slot; the screen displays the number and severity of alarms for a given port or slot.



Warning

Invisible laser radiation may be emitted from the end of the unterminated fiber cable or connector. Do not stare into the beam or view directly with optical instruments. Viewing the laser output with certain optical instruments (for example, eye loupes, magnifiers, and microscopes) within a distance of 100 mm may pose an eye hazard. Use of controls or adjustments or performance of procedures other than those specified may result in hazardous radiation exposure.

4.1.16.3 OC192 LR/STM64 LH 1550 Compatibility

Refer to the “Optical Card Software Release Compatibility” table (Table 2-6 on page 2-4) and the “Optical Card Cross-Connect Compatibility” table (Table 2-7 on page 2-5) for information on optical card compatibility.

4.1.16.4 OC192 LR/STM64 LH 1550 Card Specifications

The OC192 LR/STM64 LH 1550 card has the following specifications:

- Line
 - Bit rate: 9.96 Gbps
 - Code: Scrambled NRZ
 - Fiber: 1550-nm single-mode
 - Loopback modes: Terminal and facility



Note You must use a 19 to 24 dB (20 dB recommended) fiber attenuator when connecting a fiber loopback to an OC192 LR/STM64 LH 1550 card. Never connect a direct fiber loopback.

- Connectors: SC
- Compliance: Telcordia GR-253-CORE, ITU-T G.707, ITU-T G.957
- Transmitter
 - Maximum transmitter output power: +10 dBm
 - Minimum transmitter output power: +7 dBm
 - Center wavelength: 1530 to 1565 nm
 - Nominal wavelength: 1550 nm
 - Transmitter: LN (Lithium Niobate) external modulator transmitter
- Receiver
 - Maximum receiver level: -10 dBm
 - Minimum receiver level: -19 dBm
 - Receiver: APD/TIA
 - Link loss budget: 24 dB minimum, with no dispersion or 22 dB optical path loss at BER = $1 - \exp(-12)$ including dispersion
 - Receiver input wavelength range: 1530 to 1565 nm
 - Jitter tolerance: Telcordia GR-253/ITU-T G.823 compliant
 - Dispersion tolerance: 1360 ps/nm
- Environmental
 - Operating temperature:
 - C-Temp (15454-OC192LR1550): -5 to +55 degrees Celsius (+23 to +131 degrees Fahrenheit)
 - Operating humidity: 5 to 95%, noncondensing
 - Power consumption: 72.20 W, 1.50 A, 246.52 BTU/hr
- Dimensions
 - Height: 12.650 in. (321.3 mm)
 - Width: 0.716 in. (18.2 mm)
 - Depth: 9.000 in. (228.6 mm)
 - Weight not including clam shell: 3.1 lb (1.3 kg)
- Compliance
 - For compliance information, refer to the *Cisco Optical Transport Products Safety and Compliance Information*.

4.1.17 OC192 LR/STM64 LH ITU 15xx.xx Card

Sixteen distinct OC-192/STM-64 ITU 100 GHz DWDM cards comprise the ONS 15454 DWDM channel plan. Each OC192 LR/STM64 LH ITU 15xx.xx card provides one long-reach STM-64/OC-192 port per card, compliant with ITU-T G.707, ITU-T G.957, and and Telcordia GR-253-CORE (except minimum and maximum transmit power, and minimum receive power). The port operates at 9.95328 Gbps over unamplified distances up to 60 km (37 miles) with different types of fiber such as C-SMF or dispersion compensated fiber limited by loss and/or dispersion.

Note

Longer distances are possible in an amplified system using dispersion compensation.

The card supports VT and nonconcatenated or concatenated payloads. [Figure 4-20](#) shows the OC192 LR/STM64 LH ITU 15xx.xx faceplate.

Figure 4-20 OC192 LR/STM64 LH ITU 15xx.xx Faceplate

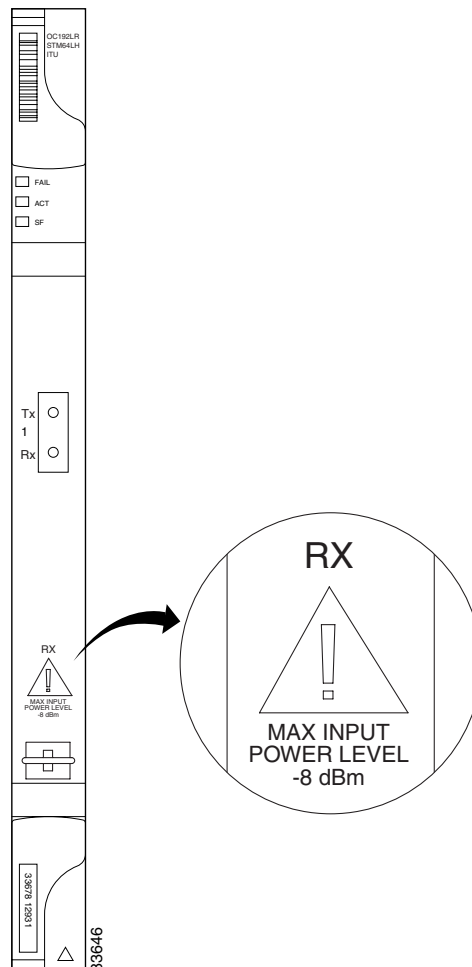

[Figure 4-21](#) shows a block diagram of the OC192 LR/STM64 LH ITU 15xx.xx card.

Figure 4-21 OC192 LR/STM64 LH ITU 15xx.xx Block Diagram

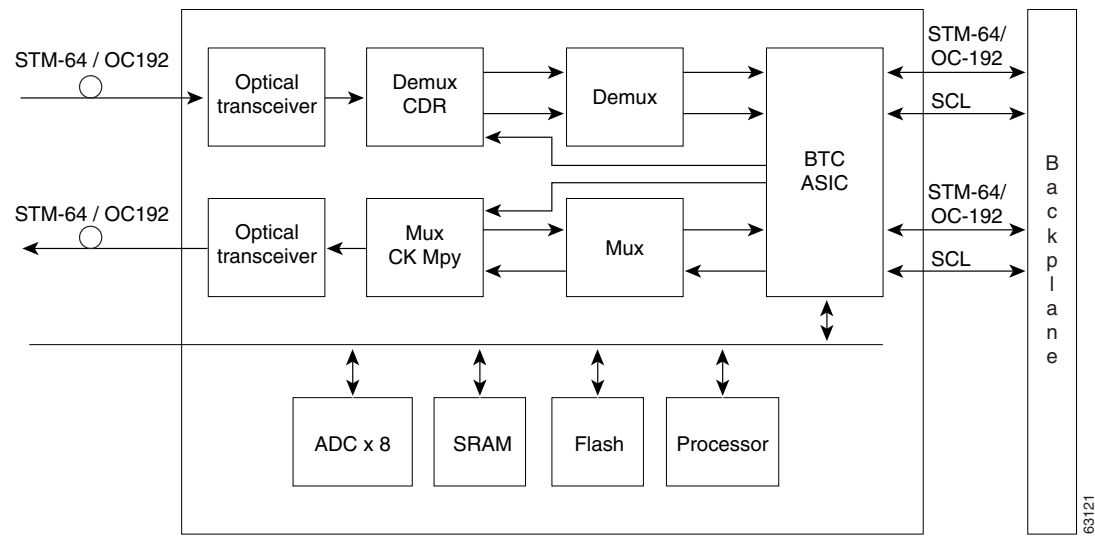
**Note**

You must use a 20-dB fiber attenuator (15 to 25 dB) when working with the OC192 LR/STM64 LH 15xx.xx card in a loopback. Do not use fiber loopbacks with the OC192 LR/STM64 LH 15xx.xx card. Using fiber loopbacks causes irreparable damage to this card.

Eight of the cards operate in the blue band with a spacing of 100 GHz in the ITU grid (1534.25 nm, 1535.04 nm, 1535.82 nm, 1536.61 nm, 1538.19 nm, 1538.98 nm, 1539.77 nm, and 1540.56 nm). The other eight cards operate in the red band with a spacing of 100 GHz in the ITU grid (1550.12 nm, 1550.92 nm, 1551.72 nm, 1552.52 nm, 1554.13 nm, 1554.94 nm, 1555.75 nm, and 1556.55 nm).

You can install OC192 LR/STM64 LH ITU 15xx.xx cards in Slot 5, 6, 12, or 13. You can provision this card as part of an BLSR, path protection, or linear configuration or also as a regenerator for longer span reaches.

The OC192 LR/STM64 LH ITU 15xx.xx port features a laser on a specific wavelength in the 1550-nm range and contains a transmit and receive connector (labeled) on the card faceplate. The card uses a dual SC connector for optical cable termination. The card supports 1+1 unidirectional and bidirectional facility protection. It also supports 1:1 protection in four-fiber BLSR applications where both span switching and ring switching might occur.

The OC192 LR/STM64 LH ITU 15xx.xx card detects SF, LOS, or LOF conditions on the optical facility. Refer to the *Cisco ONS 15454 Troubleshooting Guide* for a description of these conditions. The card also counts section and line BIP errors from B1 and B2 byte registers in the section and line overhead.

4.1.17.1 OC192 LR/STM64 LH ITU 15xx.xx Card-Level Indicators

Table 4-17 describes the three card-level LEDs on the OC192 LR/STM64 LH ITU 15xx.xx card.

Table 4-17 OC192 LR/STM64 LH ITU 15xx.xx Card-Level Indicators

Card-Level LED	Description
Red FAIL LED	The red FAIL LED indicates that the card's processor is not ready. This LED is on during reset. The FAIL LED flashes during the boot process. Replace the card if the red FAIL LED persists.
ACT/STBY LED Green (Active) Amber (Standby)	If the ACT/STBY LED is green, the card is operational and ready to carry traffic. If the ACT/STBY LED is amber, the card is operational and in standby (protect) mode.
Amber SF LED	The amber SF LED indicates a signal failure or condition such as LOS, LOF, or high BERs on one or more of the card's ports. The amber SF LED is also on if the transmit and receive fibers are incorrectly connected. If the fibers are properly connected and the link is working, the light turns off.

4.1.17.2 OC192 LR/STM64 LH ITU 15xx.xx Port-Level Indicators

You can find the status of the OC192 LR/STM64 LH ITU 15xx.xx card ports using the LCD screen on the ONS 15454 fan-tray assembly. Use the LCD to view the status of any port or card slot; the screen displays the number and severity of alarms for a given port or slot. Refer to the *Cisco ONS 15454 Troubleshooting Guide* for a complete description of the alarm messages.

4.1.17.3 OC192 LR/STM64 LH ITU 15xx.xx Card Specifications

The OC192 LR/STM64 LH ITU 15xx.xx card has the following specifications:

- Line
 - Bit rate: 9.95328 Gbps
 - Code: Scrambled NRZ
 - Fiber: 1550-nm single-mode
 - Maximum chromatic dispersion allowance:
 - in deployments with a dispersion compensation unit (DCU): +/- 1000 ps/nm, with optical signal-to-noise ration (OSNR) of 19 dB (0.5 nm RBW)
 - in deployments without a DCU: +/- 1200 ps/nm, with OSNR of 23 dB (0.5 nm RBW)
 - Loopback modes: Terminal and facility



Note You must use a 20-dB fiber attenuator (15 to 25 dB) when working with the OC192 LR/STM64 LH 15xx.xx card in a loopback. Do not use fiber loopbacks with the OC192 LR/STM64 LH 15xx.xx card. Using fiber loopbacks causes irreparable damage to this card.

- Connectors: SC
- Compliance: Telcordia GR-253-CORE, ITU-T G.707, ITU-T G.691, ITU-T G.957
- Transmitter
 - Maximum transmitter output power: +6 dBm
 - Minimum transmitter output power: +3 dBm

- Center wavelength: See wavelength plan
- Center wavelength accuracy: +/- 0.040 nm
- Transmitter: LN external modulator transmitter
- Receiver
 - Maximum receiver level: -8 dBm at BER $1 * 10 \text{ exp} - 12$
 - Minimum receiver level: -22 dBm at BER $1 * 10 \text{ exp} - 12$
 - Receiver: APD
 - Link loss budget: 25 dB minimum, plus 2 dB dispersion penalty at BER = $1 * 10 \text{ exp} - 12$ including dispersion
 - Receiver input wavelength range: 1529 to 1565 nm
- Environmental
 - Operating temperature: -5 to +55 degrees Celsius (+23 to +131 degrees Fahrenheit)
 - Operating humidity: 5 to 95%, noncondensing
 - Power consumption: 52.00 W, 1.08 A at -48 V, 177.6 BTU/hr
- Dimensions
 - Height: 12.650 in. (321.3 mm)
 - Width: 0.716 in. (18.2 mm)
 - Depth: 9.000 in. (228.6 mm)
 - Depth with backplane connector: 9.250 in. (235 mm)
 - Weight not including clam shell: 3.1 lb (1.3 kg)
- Compliance
 - For compliance information, refer to the *Cisco Optical Transport Products Safety and Compliance Information*.
- Currently available wavelengths and versions of OC192 LR/STM64 LH ITU 15xx.xx card:
ITU grid blue band:
 - 1534.25 +/- 0.040 nm, OC192 LR/STM64 LH ITU 1534.25
 - 1535.04 +/- 0.040 nm, OC192 LR/STM64 LH ITU 1535.04
 - 1535.82 +/- 0.040 nm, OC192 LR/STM64 LH ITU 1535.82
 - 1536.61 +/- 0.040 nm, OC192 LR/STM64 LH ITU 1536.61
 - 1538.19 +/- 0.040 nm, OC192 LR/STM64 LH ITU 1538.19
 - 1538.98 +/- 0.040 nm, OC192 LR/STM64 LH ITU 1538.98
 - 1539.77 +/- 0.040 nm, OC192 LR/STM64 LH ITU 1539.77
 - 1540.56 +/- 0.040 nm, OC192 LR/STM64 LH ITU 1540.56ITU grid red band:
 - 1550.12 +/- 0.040 nm, OC192 LR/STM64 LH ITU 1550.12
 - 1550.92 +/- 0.040 nm, OC192 LR/STM64 LH ITU 1550.92
 - 1551.72 +/- 0.040 nm, OC192 LR/STM64 LH ITU 1551.72
 - 1552.52 +/- 0.040 nm, OC192 LR/STM64 LH ITU 1552.52

- 1554.13 +/- 0.040 nm, OC192 LR/STM64 LH ITU 1554.13
- 1554.94 +/- 0.040 nm, OC192 LR/STM64 LH ITU 1554.94
- 1555.75 +/- 0.040 nm, OC192 LR/STM64 LH ITU 1555.75
- 1556.55 +/- 0.040 nm, OC192 LR/STM64 LH ITU 1556.55

4.2 Transponder and Muxponder Cards

This section gives an overview and detailed descriptions of the Cisco ONS 14454 transponder and muxponder cards

4.2.1 Transponder and Muxponder Card Overview



Warning

Class 1 (21 CFR 1040.10 and 1040.11) and Class 1M (IEC 60825-1 2001-01) laser products. Invisible laser radiation may be emitted from the end of the unterminated fiber cable or connector. Do not stare into the beam or view directly with optical instruments. Viewing the laser output with certain optical instruments (for example, eye loupes, magnifiers, and microscopes) within a distance of 100 mm may pose an eye hazard. Use of controls or adjustments, or performance of procedures other than those specified may result in hazardous radiation exposure. Invisible laser radiation present.



Warning

Use of controls, adjustments, or performing procedures other than those specified may result in hazardous radiation exposure.

For software and cross-connect card compatibility information, see the [“2.1.2 Card Compatibility” section on page 2-2](#).

Each card is marked with a symbol that corresponds to a slot (or slots) on the ONS 15454 shelf assembly. The cards are then installed into slots displaying the same symbols. See the [“1.13 Cards and Slots” section on page 1-42](#) for a list of slots and symbols.

[Table 4-18](#) lists the Cisco ONS 15454 transponder and muxponder cards

Table 4-18 Transponder and Muxponder Cards for the ONS 15454

Card	Port Description	For Additional Information...
TXP_MR_10G	<p>The TXP_MR_10G (10-Gbps Transponder–100-GHz–Tunable xx.xx-xx.xx) card provides one extended long-range OC-192 port (trunk side) and one short-range OC-192 port (client side). It can process one standard OC-192 interface for use in a 100-GHz DWDM system. On the trunk side, it can provide forward error correction (FEC). The card is tunable over two neighboring wavelengths in the 1550-nm, ITU 100-GHz range. It is available in four different versions, covering eight different wavelengths in the 1550-nm range. For the individual card, “xx.xx” is replaced with the wavelength intended to be used. The card operates in Slots 1 to 6 and 12 to 17.</p> <p>Note The trunk side is also known as the span side.</p>	See the “4.2.2 TXP_MR_10G Card” section on page 4-61.
MXP_2.5G_10G	<p>The MXP_2.5G_10G (2.5-Gbps–10-Gbps Muxponder–100 GHz–Tunable xx.xx-xx.xx) card provides one extended long-range OC-192 port (trunk side) and four short-range OC-48 ports (client side). It can multiplex four standard OC-48 interfaces into one OC-192 interface for use in a 100-GHz DWDM system. On the trunk side, it can provide FEC. The card is tunable over two neighboring wavelengths in the 1550-nm, ITU 100-GHz range. It is available in four different versions, covering eight different wavelengths in the 1550-nm range. For the individual card, “xx.xx” is replaced with the wavelength intended to be used. The card operates in Slots 1 to 6 and 12 to 17.</p>	See the “4.2.3 MXP_2.5G_10G Card” section on page 4-65.

Table 4-18 Transponder and Muxponder Cards for the ONS 15454 (continued)

Card	Port Description	For Additional Information...
TXP_MR_2.5G	The TXP_MR_2.5G (2.5-Gbps Multirate Transponder–100-GHz–Tunable xx.xx-xx.xx) card provides one long-range OC-48 port (trunk side) and one client side interface ranging from 8 Mbps to 2.488 Gbps. It can process one standard OC-48 interface for use in a 100-GHz DWDM system. On the trunk side, it can provide forward error correction (FEC). The card operates in Slots 1 to 6 and 12 to 17. The card is tunable over four wavelengths in the 1550 nm, ITU 100-GHz range. It is available in eight different versions, covering 32 different wavelengths in the 1550-nm range. For the individual card, “xx.xx” is replaced with the wavelengths intended to be used.	See the “4.2.4 TXP_MR_2.5G and TXPP_MR_2.5G Cards” section on page 4-71
TXPP_MR_2.5G	The TXPP_MR_2.5G (2.5-Gbps Multirate Transponder-Protected–100-GHz–Tunable xx.xx-xx.xx) card provides two long-range OC-48 ports (trunk side) and one client side interface ranging from 8 Mbps to 2.488 Gbps. It can process one standard OC-48 interface for use in a 100-GHz DWDM system. On the trunk side, it can provide FEC. The card operates in Slots 1 to 6 and 12 to 17. The card is tunable over four wavelengths in the 1550 nm, ITU 100-GHz range. It is available in eight different versions, covering 32 different wavelengths in the 1550-nm range. For the individual card, “xx.xx” is replaced with the wavelengths intended to be used.	See the “4.2.4 TXP_MR_2.5G and TXPP_MR_2.5G Cards” section on page 4-71

**Note**

The Cisco OC3 IR/STM1 SH, OC12 IR/STM4 SH, and OC48 IR/STM16 SH interface optics, all working at 1310 nm, are optimized for the most widely used SMF-28 fiber, available from many suppliers.

Corning MetroCor fiber is optimized for optical interfaces that transmit at 1550 nm or in the C and L DWDM windows, and targets interfaces with higher dispersion tolerances than those found in OC3 IR/STM1 SH, OC12 IR/STM4 SH, and OC48 IR/STM16 SH interface optics. If you are using Corning MetroCor fiber, OC3 IR/STM1 SH, OC12 IR/STM4 SH, and OC48 IR/STM16 SH interface optics become dispersion limited before they become attenuation limited. In this case, consider using OC12 LR/STM4 LH and OC48 LR/STM16 LH cards instead of OC12 IR/STM4 SH and OC48 IR/STM16 SH cards.

With all fiber types, network planners/engineers should review the relative fiber type and optics specifications to determine attenuation, dispersion, and other characteristics to ensure appropriate deployment.

4.2.2 TXP_MR_10G Card



Warning

High-performance devices on this card can get hot during operation. To remove the card, hold it by the faceplate and bottom edge. Allow the card to cool before touching any other part of it or before placing it in an antistatic bag.



Warning

Do not reach into a vacant slot or chassis while you install or remove a module or a fan. Exposed circuitry could constitute an energy hazard.

The TXP_MR_10G card (10-Gbps Transponder–100-GHz–Tunable xx.xx-xx.xx) processes one 10-Gbps signal (client side) into one 10-Gbps, 100-GHz DWDM signal (trunk side). It provides one 10Gbps port per card that can be provisioned to STM64/OC-192 Short Reach (1310nm), compliant with ITU-T G.707, G.709, ITU-T G.691, Telcordia GR-253-CORE, or to 10GE BASE-LR compliant to IEEE 802.3.

The TXP_MR_10G card is tunable over two neighboring wavelengths in the 1550-nm, ITU 100-GHz range. It is available in 16 different versions, covering 32 different wavelengths in the 1550-nm range.



Note

ITU-T G.709 specifies a form of FEC that uses a “wrapper” approach. The digital wrapper lets you transparently take in a signal on the client side, wrap a frame around it and restore it to its original form. FEC enables longer fiber links because errors caused by the optical signal degrading with distance are corrected.

The trunk port operates at 9.95328 Gbps (or 10.70923 Gbps with ITU-T G.709 Digital Wrapper/FEC) and at 10.3125 Gbps (or 11.095 Gbps with ITU-T G.709 Digital Wrapper/FEC) over unamplified distances up to 80km(50 miles) with different types of fiber such as C-SMF or dispersion-compensated fiber, limited by loss and/or dispersion.



Caution

Because the transponder has no capability to look into the payload and detect circuits, a TXP_MR_10G card does not display circuits under card view.

For the TXP_MR_10G card, protection is done using Y-cable protection. Two TXP_MR_10G cards can be joined in a Y-cable protection group. In Y-cable protection, the client ports of the two cards are joined by Y-cables. A single incoming Rx client signal is injected into the Rx Y-cable port and is split between the two TXP_MR_10G cards (connected to the Rx client ports) in the protection group. The transmit (Tx) client signals from the two protection group TXP_MR_10G cards are connected to the correspondent ports of the Tx Y-cable. Only the Tx client port of the Active TXP_MR_10G card is turned on and transmits the signal towards the receiving client equipment.



Note

If you create a GCC on either card of the protection group, the trunk (span) port stays permanently active, regardless of the switch state. When you provision a GCC, you are provisioning unprotected overhead bytes. The GCC is not protected by the protect group.

Figure 4-22 shows the TXP_MR_10G faceplate and block diagram.

Figure 4-22 TXP_MR_10G Faceplate and Block Diagram

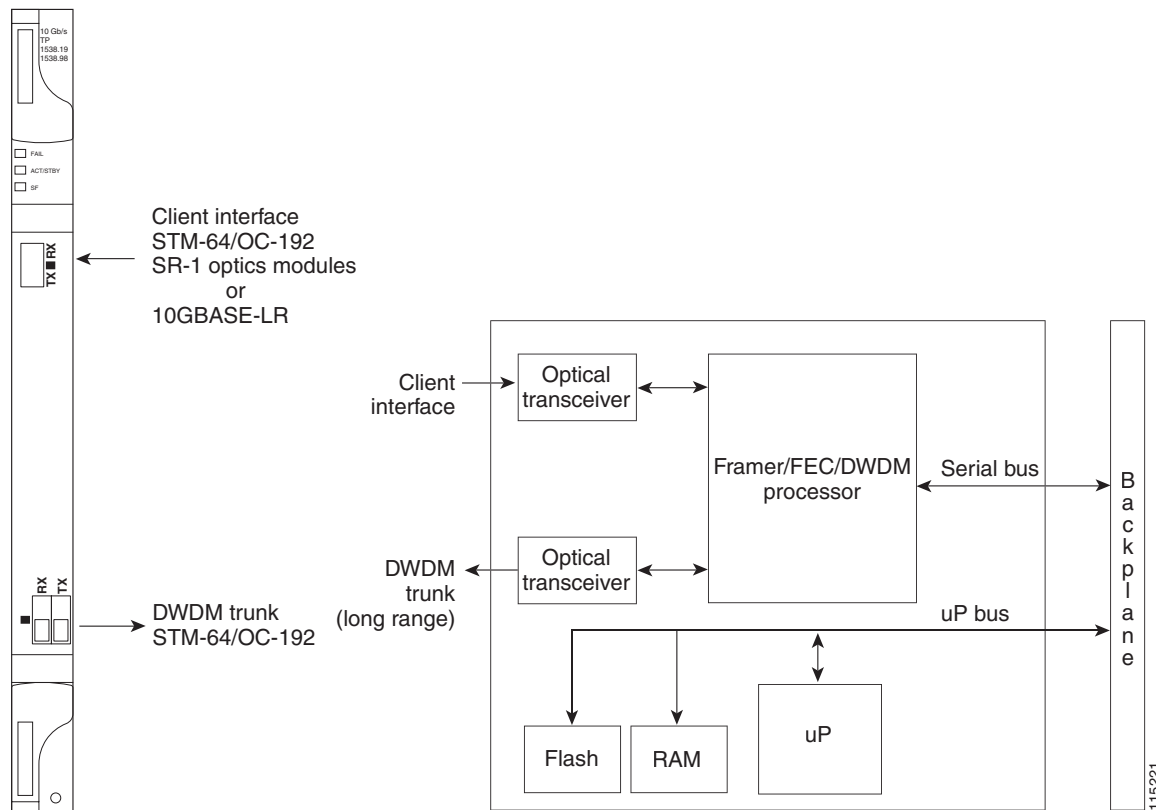
**Caution**

You must use a 15-dB fiber attenuator (10 to 20 dB) when working with the TXP_MR_10G card in a loopback on the trunk port. Do not use direct fiber loopbacks with the TXP_MR_10G card. Using direct fiber loopbacks causes irreparable damage to the TXP_MR_10G card.

You can install TXP_MR_10G cards in Slots 1 to 6 and 12 to 17. You can provision this card in a linear configuration. TXP_MR_10G cards cannot be provisioned as a BLSR, a path protection, or a regenerator. They can be used in the middle of BLSR or 1+1 spans. They can only be used in the middle of BLSR and 1+1 spans when the card is configured for transparent termination mode.

The TXP_MR_10G port features a 1550-nm laser for the trunk port and a 1310-nm laser for the client port and contains two transmit and receive connector pairs (labeled) on the card faceplate. The card uses dual LC connectors for optical cable termination.

The TXP_MR_10G card detects SF, LOS, or LOF conditions on the optical facility. Refer to the *Cisco ONS 15454 Troubleshooting Guide* for a description of these conditions. The card also counts section and line BIP errors from B1 and B2 byte registers in the section and line overhead.

4.2.2.1 TXP_MR_10G Card-Level Indicators

Table 4-19 lists the three card-level LEDs on the TXP_MR_10G card.

Table 4-19 TXP_MR_10G Card-Level Indicators

Card-Level LED	Description
Red FAIL LED	The red FAIL LED indicates that the card's processor is not ready. This LED is on during reset. The FAIL LED flashes during the boot process. Replace the card if the red FAIL LED persists.
ACT/STBY LED Green (Active) Amber (Standby)	If the ACT/STBY LED is green, the card is operational (one or both ports active) and ready to carry traffic. If the ACT/STBY LED is amber, the card is operational and in standby (protect) mode.
Amber SF LED	The amber SF LED indicates a signal failure or condition such as LOS, LOF, or high BERs on one or more of the card's ports. The amber SF LED is also on if the transmit and receive fibers are incorrectly connected. If the fibers are properly connected and the link is working, the light turns off.

4.2.2.2 TXP_MR_10G Port-Level Indicators

Table 4-20 lists the four port-level LEDs in the TXP_MR_10G card.

Table 4-20 TXP_MR_10G Port-Level Indicators

Port-Level LED	Description
Green Client LED	The green Client LED indicates that the client port is in service and that it is receiving a recognized signal.
Green DWDM LED	The green dense wavelength division multiplexing (DWDM) LED indicates that the DWDM port is in service and that it is receiving a recognized signal.
Green Wavelength 1 LED	Each port supports two wavelengths on the DWDM side. Each wavelength LED matches one of the wavelengths. This LED indicates that the board is configured for wavelength 1.
Green Wavelength 2 LED	Each port supports two wavelengths on the DWDM side. Each wavelength LED matches one of the wavelengths. This LED indicates that the board is configured for wavelength 2.

4.2.2.3 TXP_MR_10G Card Specifications

The TXP_MR_10G card has the following specifications:

- Line (trunk side)
 - Bit rate: 9.95328 Gbps for OC-192/STM-64 or 10.70923 Gbps with ITU-T G.709 Digital Wrapper/FEC
 - Code: Scrambled NRZ
 - Fiber: 1550-nm single-mode
 - Maximum chromatic dispersion allowance: 1000 ps/nm
 - Loopback modes: Terminal and facility

**Caution**

You must use a 15-dB fiber attenuator (10 to 20 dB) when working with the TXP_MR_10G card in a loopback on the trunk port. Do not use direct fiber loopbacks with the TXP_MR_10G card. Using direct fiber loopbacks causes irreparable damage to the TXP_MR_10G card.

- Connectors: LC
- Compliance Telcordia GR-253-CORE, ITU-T G.707, ITU-T G.957
- Transmitter (trunk side)
 - Transmitter output power: +3 dBm (with an accuracy of +/-0.5 dB)
 - Transmitter: LN external modulator transmitter
 - Wavelength stability (drift): +/- 25 picometers (pm)

**Note**

An optical device on the card keeps the laser wavelength locked as closely as possible to the ITU nominal value. The allowed drift is +/- 25 pm.

- Currently available wavelengths and versions of TXP_MR_10G:
 - ITU grid blue band:
 - 1538.19 to 1538.98 nm, 10T-L1-38.1
 - 1539.77 to 1540.56 nm, 10T-L1-39.7
 - ITU grid red band:
 - 1554.13 to 1554.94 nm, 10T-L1-54.1
 - 1555.75 to 1556.55 nm, 10T-L1-55.7
- Receiver (trunk side)
 - -8 to -21 dBm (no FEC, unamplified, 23 dB OSNR, BER $1 * 10^{exp - 12}$)
 - -8 to -19 dBm (no FEC, unamplified, 23 dB OSNR, @ +/- 1000 ps/nm BER $1 * 10^{exp - 12}$)
 - -8 to -20 dBm (no FEC, amplified, 19 dB OSNR, BER $1 * 10^{exp - 12}$)
 - -8 to -18 dBm (no FEC, amplified, 19 dB OSNR, @ +/- 1000 ps/nm BER $1 * 10^{exp - 12}$)
 - -8 to -24 dBm (FEC, unamplified, 23 dB OSNR, BER $8 * 10^{exp - 5}$)
 - -8 to -22 dBm (FEC, unamplified, 23 dB OSNR, @ +/- 1000 ps/nm, BER $8 * 10^{exp - 5}$)
 - -8 to -18 dBm (FEC, amplified, 9 dB OSNR, BER $8 * 10^{exp - 5}$)
 - -8 to -18 dBm (FEC, unamplified, 11 dB OSNR, @ +/- 800 ps/nm, BER $8 * 10^{exp - 5}$)
 - Receiver: APD
 - Link loss budget: 24 dB minimum, with no dispersion or 22 dB optical path loss at BER = $1 * 10^{exp - 12}$ including dispersion
 - Receiver input wavelength range: 1290 to 1605 nm
- Line (client side)
 - Bit rate: 9.95328 Gbps
 - Code: Scrambled NRZ
 - Fiber: 1550-nm single-mode
 - Maximum chromatic dispersion allowance: 1600 ps/nm

- Loopback modes: Terminal and facility
- Connectors: LC
- Compliance: Telcordia GR-253-CORE, ITU-T G.707, ITU-T G.957
- Transmitter (client side)
 - Maximum transmitter output power: –1 dBm
 - Minimum transmitter output power: –6 dBm
 - Center wavelength: 1290 to 1330 nm
 - Nominal wavelength: 1310 nm
 - Transmitter: DFB laser
- Receiver (client side)
 - Receiver level:
 - For OC-192, compliant with SR-1 Telcordia GR253 (-1 to -11 dBm)
 - For 10GE LAN PHY, compliant with IEEE 802.3ae (-1 to -14.4 dBm)
 - Receiver: APD
 - Link loss budget: 8 dB minimum, at BER = $1 * 10 \exp - 12$
 - Receiver input wavelength range: 1290 to 1605 nm
- Environmental
 - Operating temperature: –5 to +55 degrees Celsius (+23 to +113 degrees Fahrenheit)
 - Operating humidity: 5 to 95%, noncondensing
 - Power consumption: 35.00 W, 0.73 A at –48 V, 119.5 BTU/hr
- Dimensions
 - Height: 12.650 in. (321.3 mm)
 - Width: 0.716 in. (18.2 mm)
 - Depth: 9.000 in. (228.6 mm)
 - Depth with backplane connector: 9.250 in. (235 mm)
 - Weight not including clam shell: 3.1 lb (1.3 kg)
- Compliance
 - For compliance information, refer to the *Cisco Optical Transport Products Safety and Compliance Information*.

4.2.3 MXP_2.5G_10G Card



Warning

High-performance devices on this card can get hot during operation. To remove the card, hold it by the faceplate and bottom edge. Allow the card to cool before touching any other part of it or before placing it in an antistatic bag.

**Warning**

Do not reach into a vacant slot or chassis while you install or remove a module or a fan. Exposed circuitry could constitute an energy hazard.

The MXP_2.5G_10G card (2.5-Gbps–10-Gbps Muxponder–100 GHz–Tunable xx.xx-xx.xx) multiplexes/demultiplexes four 2.5-Gbps signals (client side) into one 10-Gbps, 100-GHz DWDM signal (trunk side). It provides one extended long-range STM-64/OC-192 port per card on the trunk side (compliant with ITU-T G.707, G.709, ITU-T G.957, and Telcordia GR-253-CORE) and four intermediate- or short-range OC-48/STM-16 ports per card on the client side. The port operates at 9.95328 Gbps over unamplified distances up to 80 km (50 miles) with different types of fiber such as C-SMF or dispersion compensated fiber limited by loss and/or dispersion.

Client ports on the MXP_2.5G_10G card are also interoperable with OC-1 (STS-1) fiber optic signals defined in Telcordia GR.252-CORE. An OC-1 signal is the equivalent of one DS-3 channel transmitted across optical fiber. OC-1 is primarily used for trunk interfaces to phone switches in the United States. There is no SDH equivalent for OC-1.

The MXP_2.5G_10G card is tunable over two neighboring wavelengths in the 1550-nm, ITU 100-GHz range. It is available in four different versions, covering eight different wavelengths in the 1550-nm range.

**Note**

ITU-T G.709 specifies a form of FEC that uses a “wrapper” approach. The digital wrapper lets you transparently take in a signal on the client side, wrap a frame around it and restore it to its original form. FEC enables longer fiber links because errors caused by the optical signal degrading with distance are corrected.

The port can also operate at 10.70923 Gbps in ITU-T G.709 Digital Wrapper/FEC mode.

**Caution**

Because the transponder has no capability to look into the payload and detect circuits, an MXP_2.5G_10G card does not display circuits under card view.

For the MXP_2.5G_10G card, protection is done using Y-cable protection. Two MXP_2.5G_10G cards can be joined in a Y-cable protection group. In Y-cable protection, the client ports of the two cards are joined by Y-cables. A single receive (Rx) client signal is injected into the Rx Y-cable and is split between the two MXP_2.5G_10G cards in the protection group. The transmit (TX) client signals from the two protection group MXP_2.5G_10G cards are connected via the TX Y-cable with only the active card signal passing through as the single TX client signal.

**Note**

If you create a GCC on either card of the protect group, the trunk port stays permanently active, regardless of the switch state. When you provision a GCC, you are provisioning unprotected overhead bytes. The GCC is not protected by the protect group.

Figure 4-23 shows the MXP_2.5G_10G faceplate.

Figure 4-23 MXP_2.5G_10G Faceplate

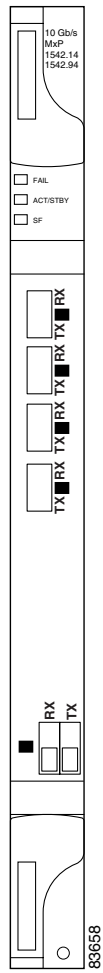
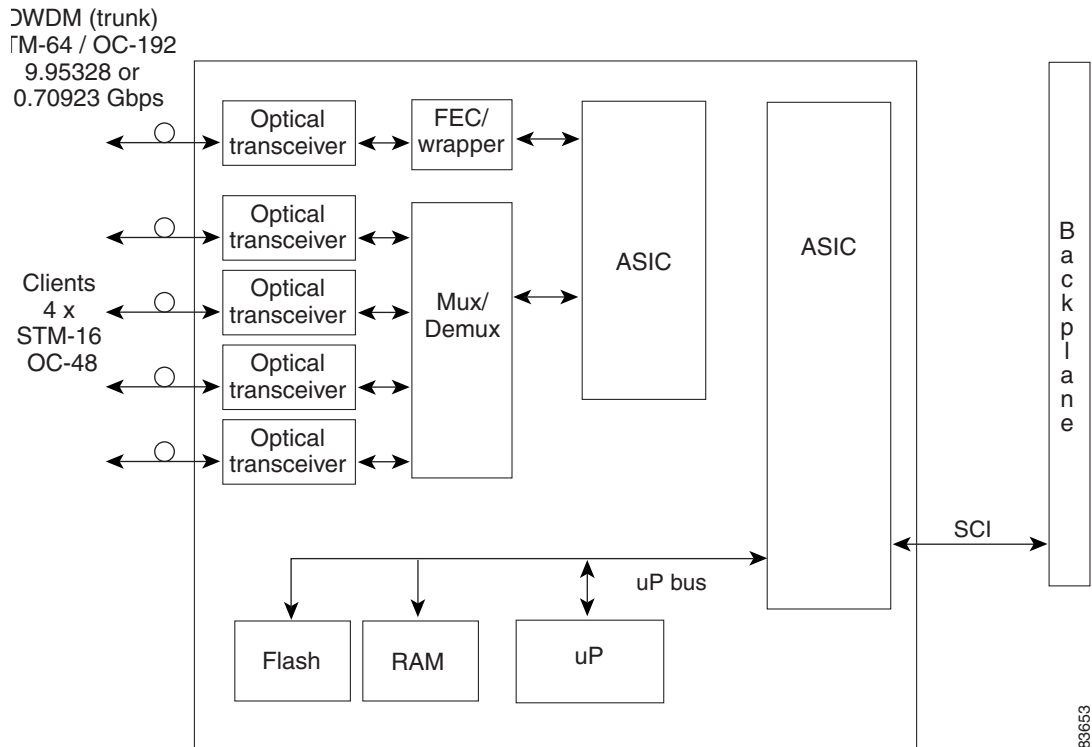

Figure 4-24 shows a block diagram of the MXP_2.5G_10G card.

Figure 4-24 MXP_2.5G_10G Block Diagram

**Caution**

You must use a 20-dB fiber attenuator (15 to 25 dB) when working with the MXP_2.5G_10G card in a loopback on the trunk port. Do not use direct fiber loopbacks with the MXP_2.5G_10G card. Using direct fiber loopbacks causes irreparable damage to the MXP_2.5G_10G card.

You can install MXP_2.5G_10G cards in Slots 1 to 6 and 12 to 17. You can provision this card in a linear configuration. MXP_2.5G_10G cards cannot be provisioned as a BLSR, a path protection, or a regenerator. They can be used in the middle of BLSR or 1+1 spans. They can only be used in the middle of BLSR and 1+1 spans when the card is configured for transparent termination mode.

The MXP_2.5G_10G port features a 1550-nm laser on the trunk port and four 1310-nm lasers on the client ports and contains five transmit and receive connector pairs (labeled) on the card faceplate. The card uses a dual LC connector on the trunk side and small form factor pluggable (SFP) connectors on the client side for optical cable termination.

The MXP_2.5G_10G card detects SF, LOS, or LOF conditions on the optical facility. Refer to the *Cisco ONS 15454 Troubleshooting Guide* for a description of these conditions. The card also counts section and line BIP errors from B1 and B2 byte registers in the section and line overhead.

4.2.3.1 Timing Synchronization

The MXP_2.5G_10G card is synchronized to the TCC clock during normal conditions and transmits the ITU-T G.709 frame using this clock. The TCC can operate from an external BITS clock, an internal Stratum 3 clock, or from clock recovered from one of the four valid client clocks. If clocks from both TCC cards are not available, the MXP_2.5G_10G card switches automatically (with errors, not hitless) to an internal 19.44 MHz clock that does not meet SONET clock requirements. This will result in a clock alarm.

4.2.3.2 MXP_2.5G_10G Card-Level Indicators

Table 4-21 describes the three card-level LEDs on the MXP_2.5G_10G card.

Table 4-21 MXP_2.5G_10G Card-Level Indicators

Card-Level LED	Description
Red FAIL LED	The red FAIL LED indicates that the card's processor is not ready. This LED is on during reset. The FAIL LED flashes during the boot process. Replace the card if the red FAIL LED persists.
ACT/STBY LED Green (Active) Amber (Standby)	If the ACT/STBY LED is green, the card is operational (one or more ports active) and ready to carry traffic. If the ACT/STBY LED is amber, the card is operational and in standby (protect) mode.
Amber SF LED	The amber SF LED indicates a signal failure or condition such as LOS, LOF, or high BERs on one or more of the card's ports. The amber SF LED is also on if the transmit and receive fibers are incorrectly connected. If the fibers are properly connected and the link is working, the light turns off.

4.2.3.3 MXP_2.5G_10G Port-Level Indicators

Table 4-22 describes the seven port-level LEDs on the MXP_2.5G_10G card.

Table 4-22 MXP_2.5G_10G Port-Level Indicators

Port-Level LED	Description
Green Client LED (four LEDs)	The green Client LED indicates that the client port is in service and that it is receiving a recognized signal. The card has four client ports, and so has four Client LEDs.
Green DWDM LED	The green DWDM LED indicates that the DWDM port is in service and that it is receiving a recognized signal.
Green Wavelength 1 LED	Each port supports two wavelengths on the DWDM side. Each wavelength LED matches one of the wavelengths. This LED indicates that the board is configured for wavelength 1.
Green Wavelength 2 LED	Each port supports two wavelengths on the DWDM side. Each wavelength LED matches one of the wavelengths. This LED indicates that the board is configured for wavelength 2.

4.2.3.4 MXP_2.5G_10G Card Specifications

The MXP_2.5G_10G card has the following specifications:

- Line (trunk side)
 - Bit rate: 9.95328 Gbps for OC-192/STM-64 or 10.70923 Gbps with ITU-T G.709 Digital Wrapper/FEC
 - Code: Scrambled NRZ
 - Fiber: 1550-nm single-mode
 - Maximum chromatic dispersion allowance: 1000 ps/nm

- Loopback modes: Terminal and facility

**Caution**

You must use a 20-dB fiber attenuator (15 to 25 dB) when working with the MXP_2.5G_10G card in a loopback on the trunk port. Do not use direct fiber loopbacks with the MXP_2.5G_10G card. Using direct fiber loopbacks causes irreparable damage to the MXP_2.5G_10G card.

- Connectors: LC
- Compliance: Telcordia GR-253-CORE, ITU-T G.707, ITU-T G.957
- Transmitter (trunk side)
 - Transmitter output power: +3 dBm (with an accuracy of +/- 0.5dB)
 - Transmitter: LN external modulator transmitter
 - Wavelength stability (drift): +/- 25 picometers (pm)

**Note**

An optical device on the card keeps the laser wavelength locked as closely as possible to the ITU nominal value. The allowed drift is +/- 25 pm.

- Currently available wavelengths and versions of MXP_2.5G_10G:
 - ITU grid blue band:
 - 1542.14 to 1542.94 nm, 10M-L1-42.1
 - 1543.73 to 1544.53 nm, 10M-L1-43.7
 - ITU grid red band:
 - 1558.17 to 1558.98 nm, 10M-L1-58.1
 - 1559.79 to 1560.61 nm, 10M-L1-59.7
- Receiver (trunk side)
 - -8 to -21 dBm (no FEC, unamplified, 23 dB OSNR, BER $1 * 10^{exp - 12}$)
 - -8 to -19 dBm (no FEC, unamplified, 23 dB OSNR, @ +/- 1000 ps/nm BER $1 * 10^{exp - 12}$)
 - -8 to -20 dBm (no FEC, amplified, 19 dB OSNR, BER $1 * 10^{exp - 12}$)
 - -8 to -18 dBm (no FEC, amplified, 19 dB OSNR, @ +/- 1000 ps/nm BER $1 * 10^{exp - 12}$)
 - -8 to -24 dBm (FEC, unamplified, 23 dB OSNR, BER $8 * 10^{exp - 5}$)
 - -8 to -22 dBm (FEC, unamplified, 23 dB OSNR, @ +/- 1000 ps/nm, BER $8 * 10^{exp - 5}$)
 - -8 to -18 dBm (FEC, amplified, 9 dB OSNR, BER $8 * 10^{exp - 5}$)
 - -8 to -18 dBm (FEC, unamplified, 11 dB OSNR, @ +/- 800 ps/nm, BER $8 * 10^{exp - 5}$)
 - Receiver: APD
 - Link loss budget: 24 dB minimum, with no dispersion or 22 dB optical path loss at BER = $1 * 10^{exp - 12}$ including dispersion
 - Receiver input wavelength range: 1290 to 1605 nm
- Line (client side)
 - Bit rate: 2.48832 Gbps
 - Code: Scrambled NRZ

- Fiber: 1550-nm single-mode
- Maximum chromatic dispersion allowance: 1600 ps/nm
- Loopback modes: Terminal and facility
- Connectors: SFF
- Compliance: Telcordia GR-253-CORE, ITU-T G.707, ITU-T G.957
- Transmitter (client side)
 - Depends on SFP that is used. There are two SFPs available: 15454-SFP-OC48-IR (1310 nm for OC48/DV6000, intermediate reach) and ONS-SE-2G-S1 (1310 nm for OC48/STM-16, short reach). See the “4.2.7 SFP Modules” section on page 4-81 and the document titled “Installing GBIC, SFP and XFP Optics Modules in Cisco ONS 15454, 15327, 15600, and 15310 Platforms” for more details.
- Receiver (client side)
 - Depends on SFP that is used. There are two SFPs available: 15454-SFP-OC48-IR (1310 nm for OC48/DV6000, intermediate reach) and ONS-SE-2G-S1 (1310 nm for OC48/STM-16, short reach). See the “4.2.7 SFP Modules” section on page 4-81 and the document titled “Installing GBIC, SFP and XFP Optics Modules in Cisco ONS 15454, 15327, 15600, and 15310 Platforms” for more details.
- Environmental
 - Operating temperature: –5 to +55 degrees Celsius (+23 to +113 degrees Fahrenheit)
 - Operating humidity: 5 to 95%, noncondensing
 - Power consumption: 50.00 W, 1.04 A at –48 V, 170.7 BTU/hr
- Dimensions
 - Height: 12.650 in. (321.3 mm)
 - Width: 0.716 in. (18.2 mm)
 - Depth: 9.000 in. (228.6 mm)
 - Depth with backplane connector: 9.250 in. (235 mm)
 - Weight not including clam shell: 3.1 lb (1.3 kg)
- Compliance
 - For compliance information, refer to the *Cisco Optical Transport Products Safety and Compliance Information*.

4.2.4 TXP_MR_2.5G and TXPP_MR_2.5G Cards



Warning

High-performance devices on this card can get hot during operation. To remove the card, hold it by the faceplate and bottom edge. Allow the card to cool before touching any other part of it or before placing it in an antistatic bag.



Warning

Do not reach into a vacant slot or chassis while you install or remove a module or a fan. Exposed circuitry could constitute an energy hazard.

The TXP_MR_2.5G card (2.5-Gbps Multirate Transponder–100-GHz–Tunable xx.xx-xx.xx) processes one 8-Mbps to 2.488-Gbps signal (client side) into one 8-Mbps to 2.5-Gbps, 100-GHz DWDM signal (trunk side). It provides one long-reach STM-16/OC-48 port per card, compliant with ITU-T G.707, ITU-T G.709, ITU-T G.957, and Telcordia GR-253-CORE.

The TXPP_MR_2.5G card (2.5-Gbps Multirate Transponder-Protected–100-GHz–Tunable xx.xx-xx.xx) processes one 8-Mbps to 2.488-Gbps signal (client side) into two 8-Mbps to 2.5-Gbps, 100-GHz DWDM signals (trunk side). It provides two long-reach STM-16/OC-48 ports per card, compliant with ITU-T G.707, ITU-T G.957, and Telcordia GR-253-CORE.

The TXP_MR_2.5G and TXPP_MR_2.5G cards are tunable over four wavelengths in the 1550-nm, ITU 100-GHz range. They are available in eight versions, covering 32 different wavelengths in the 1550-nm range.

**Note**

ITU-T G.709 specifies a form of FEC that uses a “wrapper” approach. The digital wrapper lets you transparently take in a signal on the client side, wrap a frame around it, and restore it to its original form. FEC enables longer fiber links because errors caused by the optical signal degrading with distance are corrected.

The trunk/line port operates at up to 2.488 Gbps (or up to 2.66 Gbps with ITU-T G.709 Digital Wrapper/FEC) over unamplified distances up to 360 km (223.7 miles) with different types of fiber such as C-SMF or higher if dispersion compensation is used.

**Caution**

Because the transponder has no capability to look into the payload and detect circuits, a TXP_MR_2.5G or TXPP_MR_2.5G card does not display circuits under card view.

For the TXP_MR_2.5G card, protection is done using Y-cable protection. Two TXP_MR_2.5G cards can be joined in a Y-cable protection group. In Y-cable protection, the client ports of the two cards are joined by Y-cables. A single incoming Rx client signal is injected into the Rx Y-cable port and is split between the two TXP_MR_2.5G cards (connected to the Rx client ports) in the protection group. The transmit (Tx) client signals from the two protection group TXP_MR_2.5G cards are connected to the correspondent ports of the Tx Y-cable. Only the Tx client port of the Active TXP_MR_2.5G card is turned on and transmits the signal towards the receiving client equipment.

**Note**

If you create a GCC on either card of the protect group, the trunk (span) port stays permanently active, regardless of the switch state. When you provision a GCC, you are provisioning unprotected overhead bytes. The GCC is not protected by the protect group.

For the TXPP_MR_2.5G card, protection is done using splitter protection. In splitter protection, the single client signal is injected into the client receive (Rx) port. It is then split into two separate signals on the two trunk transmit (Tx) ports. The two signals are transmitted over diverse paths. The far-end TXPP_MR_2.5G card chooses one of the two trunk receive (Rx) port signals and injects it into the transmit (Tx) client port. The TXPP_MR_2.5G card switches the selected trunk receive (Rx) port signal in case of failure.

The TXP_MR_2.5G and TXPP_MR_2.5G cards support 2R and 3R+ modes of operation where the client signal is mapped into a ITU-T G.709 frame. The mapping function is simply done by placing a digital wrapper around the client signal. Only OC-48/STM-16 client signals are fully ITU-T G.709 compliant, and the output bit rate depends on the input client signal. [Table 4-23](#) shows the possible combinations of client interfaces, input bit rates, 2R and 3R modes, and ITU-T G.709 monitoring.

Table 4-23 2R and 3R Mode and ITU-T G.709 Compliance by Client Interface

Client Interface	Input Bit Rate	3R vs. 2R	ITU-T G.709
OC-48/STM-16	2.488 Gbps	3R	On or Off
DV-6000	2.38 Gbps	2R	—
2 Gigabit Fiber Channel (2G-FC)/FICON	2.125 Gbps	3R ¹	On or Off
High definition television (HDTV)	1.48 Gbps	2R	—
Gigabit Ethernet (GE)	1.25 Gbps	3R	On or Off
1 Gigabit Fiber Channel (1G-FC)/FICON	1.06 Gbps	3R	On or Off
OC-12/STM-4	622 Mbps	3R	On or Off
OC-3/STM-1	155 Mbps	3R	On or Off
ESCON	200 Mbps	2R	—
SDI/D1 Video	270 Mbps	2R	—

1. No monitoring

The output bit rate is calculated for the trunk bit rate by using the 255/238 ratio as specified in ITU-T G.709 for OTU1. [Table 4-24](#) lists the calculated trunk bit rates for the client interfaces with ITU-T G.709 enabled.

Table 4-24 Trunk Bit Rates With ITU-T G.709 Enabled

Client Interface	ITU-T G.709 Disabled	ITU-T G.709 Enabled
OC-48/STM-16	2.488 Gbps	2.66 Gbps
2G-FC	2.125 Gbps	2.27 Gbps
GE	1.25 Gbps	1.34 Gbps
1G-FC	1.06 Gbps	1.14 Gbps
OC-12/STM-3	622 Mbps	666.43 Mbps
OC-3/STM-1	155 Mbps	166.07 Mbps

For 2R operation mode, the TXP_MR_2.5G and TXPP_MR_2.5G cards have the ability to pass data through transparently from client side interfaces to a trunk side interface, which resides on an ITU grid. The data might vary at any bit rate from 200-Mbps up to 2.38-Gbps, including ESCON and video signals. In this pass-through mode, no performance monitoring (PM) or digital wrapping of the incoming signal is provided, except for the usual PM outputs from the SFPs. Similarly, this card has the ability to pass data through transparently from the trunk side interfaces to the client side interfaces with bit rates varying from 200-Mbps up to 2.38-Gbps. Again, no performance monitoring or digital wrapping of received signals is available in this pass-through mode.

For 3R+ operation mode, the TXP_MR_2.5G and TXPP_MR_2.5G cards apply a digital wrapper to the incoming client interface signals (OC-N, 1G-FC, 2G-FC, GE). Performance monitoring is available on all of these signals except for 2G-FC, and varies depending upon the type of signal. For client inputs other than OC-48/STM-16, a digital wrapper might be applied but the resulting signal is not ITU-T G.709 compliant. The card applies a digital wrapper that is scaled to the frequency of the input signal.

The TXP_MR_2.5G and TXPP_MR_2.5G card has the ability to take digitally wrapped signals in from the trunk interface, remove the digital wrapper, and send the unwrapped data through to the client interface. Performance monitoring of the ITU-T G.709 OH and SONET/SDH OH is implemented. Figure 4-25 shows the TXP_MR_2.5G and TXPP_MR_2.5G faceplate.

Figure 4-25 TXP_MR_2.5G and TXPP_MR_2.5G Faceplates

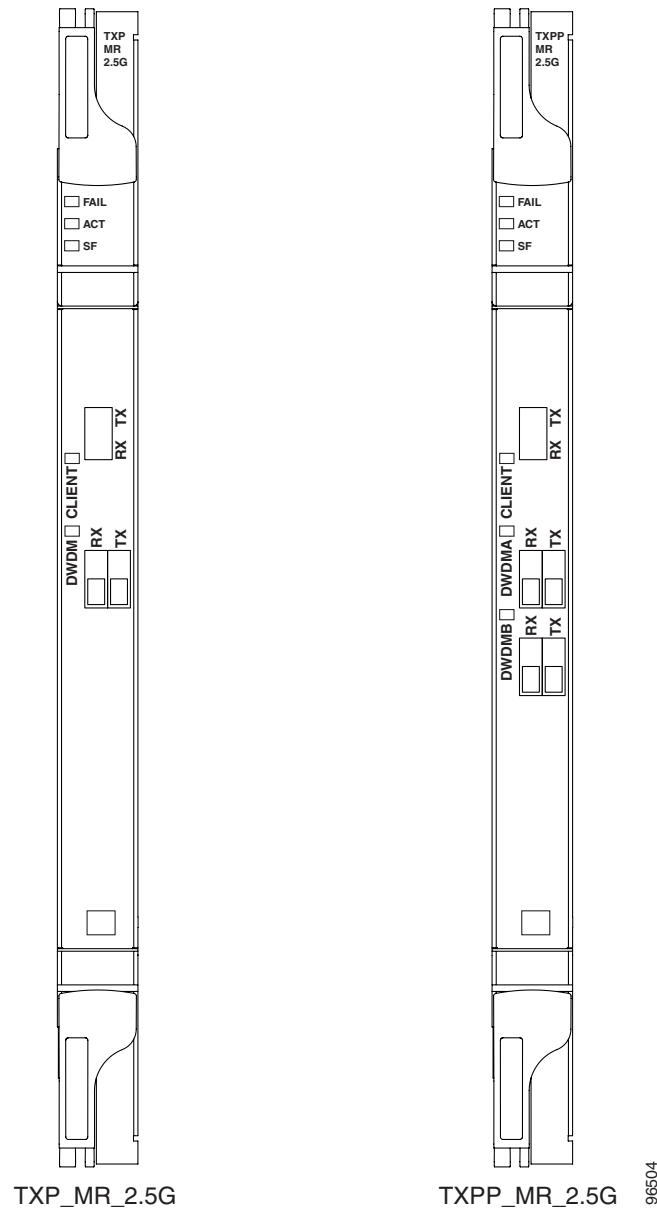
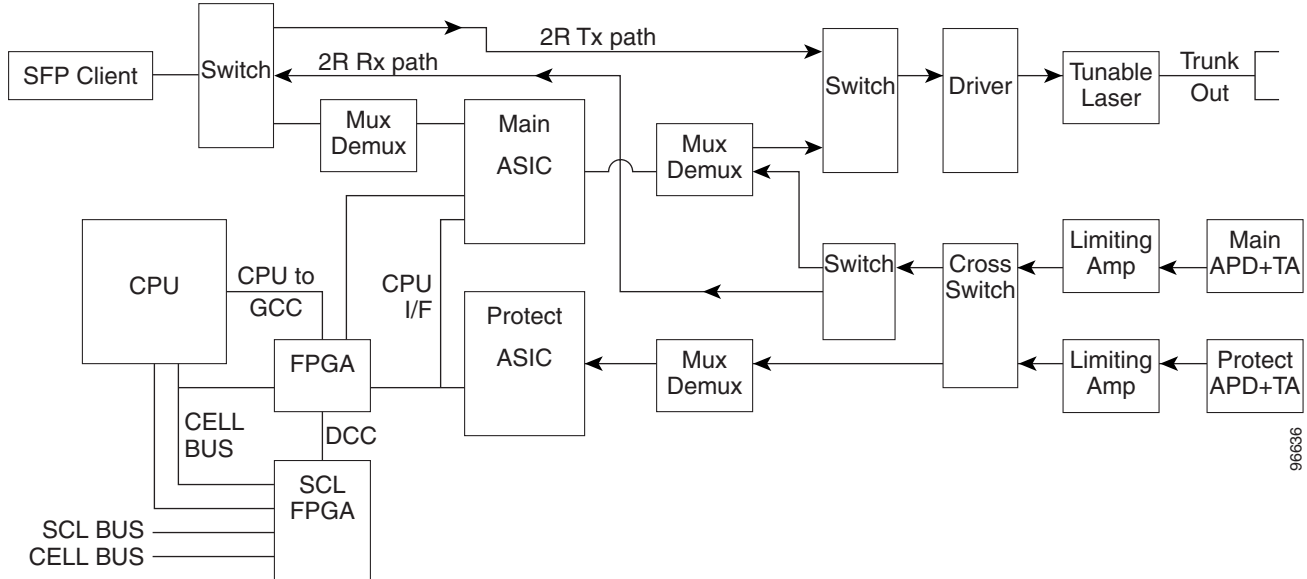

Figure 4-26 shows a block diagram of the TXP_MR_2.5G and TXPP_MR_2.5G cards.

Figure 4-26 TXP_MR_2.5G and TXPP_MR_2.5G Block Diagram

**Caution**

You must use a 20-dB fiber attenuator (15 to 25 dB) when working with the TXP_MR_2.5G and TXPP_MR_2.5G cards in a loopback on the trunk port. Do not use direct fiber loopbacks with the TXP_MR_2.5G and TXPP_MR_2.5G cards. Using direct fiber loopbacks causes irreparable damage to the TXP_MR_2.5G and TXPP_MR_2.5G cards.

You can install TXP_MR_2.5G and TXPP_MR_2.5G cards in Slots 1 to 6 and 12 to 17. You can provision this card in a linear configuration. TXP_MR_10G and TXPP_MR_2.5G cards cannot be provisioned as a BLSR, a path protection, or a regenerator. They can be used in the middle of BLSR or 1+1 spans. They can only be used in the middle of BLSR and 1+1 spans when the card is configured for transparent termination mode.

The TXP_MR_2.5G card features a 1550-nm laser for the trunk/line port and a 1310-nm laser for the client port and contains two transmit and receive connector pairs (labeled) on the card faceplate. The card uses dual LC connectors for optical cable termination.

The TXPP_MR_2.5G card features a 1550-nm laser for the trunk/line port and a 1310-nm or 850-nm laser (depending on the SFP) for the client port and contains three transmit and receive connector pairs (labeled) on the card faceplate. The card uses dual LC connectors for optical cable termination.

The TXP_MR_2.5G and TXPP_MR_2.5G cards detect SF, LOS, or LOF conditions on the optical facility. Refer to the *Cisco ONS 15454 Troubleshooting Guide* for a description of these conditions. The card also counts section and line BIP errors from B1 and B2 byte registers in the section and line overhead.

4.2.4.1 TXP_MR_2.5G and TXPP_MR_2.5G Safety Labels

The TXP_MR_2.5G and TXPP_MR_2.5G cards have several safety labels that provide laser radiation and electrical shock warnings.

Figure 4-27 shows the laser radiation warning hazard level label. The faceplate of these cards are clearly labeled with warnings about the equipment radiation level. Personnel must understand all warning labels before working with these cards. The hazard level label warns the personnel against exposure to laser radiation of Class 1 limits calculated in accordance with IEC60825-1 Ed.1.2.

Figure 4-27 Laser Radiation Warning—Hazard Level Label



Figure 4-28 shows the laser source connector label. This label indicates a laser source at the optical connectors where it has been placed.

Figure 4-28 Laser Radiation Warning—Laser Source Connector Label

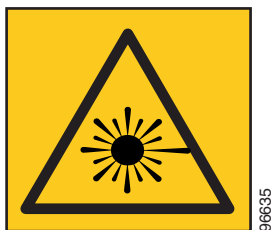

Figure 4-29 shows the FDA compliance label. This label shows the statement of compliance to FDA standards and that the hazard level classification is in accordance with IEC60825-1 Am.2 or Ed.1.2.

Figure 4-29 FDA Compliance Statement Label

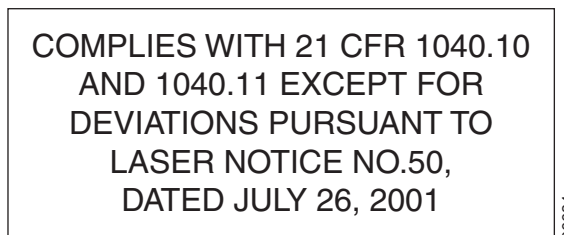
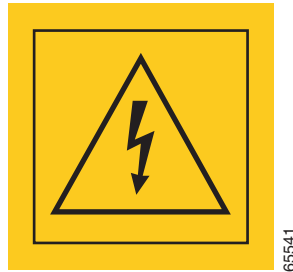

Figure 4-30 shows the electrical energy hazard label. This label alerts personnel to electrical hazards within the card. The potential of shock hazard exists when adjacent cards are removed during maintenance and touching exposed electrical circuitry on the card itself.

Figure 4-30 Electrical Energy Hazard Label

4.2.4.2 TXP_MR_2.5G and TXPP_MR_2.5G Card-Level Indicators

Table 4-25 lists the three card-level LEDs on the TXP_MR_2.5G and TXPP_MR_2.5G cards.

Table 4-25 TXP_MR_10G and TXPP_MR_2.5G Card-Level Indicators

Card-Level LED	Description
Red FAIL LED	The red FAIL LED indicates that the card's processor is not ready. This LED is on during reset. The FAIL LED flashes during the boot process. Replace the card if the red FAIL LED persists.
ACT/STBY LED Green (Active) Amber (Standby)	If the ACT/STBY LED is green, the card is operational (one or both ports active) and ready to carry traffic. If the ACT/STBY LED is amber, the card is operational and in standby (protect) mode.
Amber SF LED	The amber SF LED indicates a signal failure or condition such as LOS, LOF, or high BERs on one or more of the card's ports. The amber SF LED is also on if the transmit and receive fibers are incorrectly connected. If the fibers are properly connected and the link is working, the light turns off.

4.2.4.3 TXP_MR_2.5G and TXPP_MR_2.5G Port-Level Indicators

Table 4-26 lists the four port-level LEDs on the TXP_MR_2.5G and TXPP_MR_2.5G cards.

Table 4-26 TXP_MR_10G Port-Level Indicators

Port-Level LED	Description
Green Client LED	The green Client LED indicates that the client port is in service and that it is receiving a recognized signal.
Green DWDM LED	The green DWDM LED indicates that the DWDM port is in service and that it is receiving a recognized signal.
Green TX LED	The green TX LED indicates that indicated the DWDM port is in service and that it is currently transmitting a recognized signal.
Green RX LED	The green RX LED indicates that the indicated DWDM port is in service and that it is currently receiving a recognized signal.

4.2.4.4 TXP_MR_2.5G and TXPP_MR_2.5G Card Specifications

The TXP_MR_2.5G and TXPP_MR_2.5G cards have the following specifications:

- Line (trunk side)
 - Bit rate: 2.488 Gbps for OC-48/STM-16 or 2.66 Gbps with ITU-T G.709 Digital Wrapper/FEC
 - Code: Scrambled NRZ
 - Fiber: 1550-nm single-mode
 - Maximum chromatic dispersion allowance: 6000 ps/nm
 - Loopback modes: Terminal and facility



Caution

You must use a 20-dB fiber attenuator (15 to 25 dB) when working with the TXP_MR_2.5G and TXPP_MR_2.5G cards in a loopback on the trunk port. Do not use direct fiber loopbacks with the TXP_MR_2.5G and TXPP_MR_2.5G cards. Using direct fiber loopbacks causes irreparable damage to the TXP_MR_2.5G and TXPP_MR_2.5G cards.

- Connectors: LC
- Compliance Telcordia GR-253-CORE, ITU-T G.707, ITU-T G.957
- Transmitter (trunk side)
 - Maximum transmitter output power: +1 dBm
 - Minimum transmitter output power: -4.5 dBm
 - Transmitter: Direct modulated laser
 - Wavelength stability (drift): +/- 25 picometers (pm)



Note

An optical device on the card keeps the laser wavelength locked as closely as possible to the ITU nominal value. The allowed drift is +/- 25 pm.

- Currently available wavelengths of TXP_MR_2.5G and TXPP_MR_2.5G:
 - ITU grid blue band:
 - 1530.334 to 1544.526 nm
 - ITU grid red band:
 - 1546.119 to 1560.606 nm
- Receiver (trunk side)
 - Receiver input power (no FEC, unamplified, BER $1 * 10^{exp - 12}$): -9 to -30 dBm
 - Receiver input power (FEC, unamplified, BER $1 * 10^{exp - 6}$): -9 to -31 dBm
 - Receiver input power (no FEC, amplified, BER $1 * 10^{exp - 12}$): -9 to -23 dBm
 - Receiver input power (FEC, amplified, BER $1 * 10^{exp - 6}$): -9 to -25 dBm
 - Receiver: APD
 - Link loss budget: 24 dB minimum, with no dispersion or 22 dB optical path loss at BER = $1 * 10^{exp - 12}$ including dispersion
 - Receiver input wavelength range: 1290 to 1605 nm

- Line (client side)
 - Bit rate: 8 Mbps to 2.488 Gbps
 - Code: Scrambled NRZ
 - Fiber: 1310-nm single-mode
 - Maximum chromatic dispersion allowance: 1600 ps/nm
 - Loopback modes: Terminal and facility
 - Connectors: LC
 - Compliance: Telcordia GR-253-CORE, ITU-T G.707, ITU-T G.957
- Transmitter (client side)
 - Depends on SFP that is used. There are 13 SFPs available: 15454-SFP3-1-IR, 15454E-SFP-L.1.1, 15454-SFP12-4-IR, 15454E-SFP-L.4.1, 15454-SFP-OC48-IR, 15454E-SFP-L.16.1, ONS-SE-2G-S1, 15454-SFP-200, 15454E-SFP-200, 15454-SFP-GEFC-SX, 15454E-SFP-GEFC-S, 15454-SFP-GE+-LX, and 15454E-SFP-GE+-LX. See the “4.2.7 SFP Modules” section on page 4-81 and the document titled “Installing GBIC, SFP and XFP Optics Modules in Cisco ONS 15454, 15327, 15600, and 15310 Platforms” for more details and specifications.
- Receiver (client side)
 - Depends on SFP that is used. There are 13 SFPs available: 15454-SFP3-1-IR, 15454E-SFP-L.1.1, 15454-SFP12-4-IR, 15454E-SFP-L.4.1, 15454-SFP-OC48-IR, 15454E-SFP-L.16.1, ONS-SE-2G-S1, 15454-SFP-200, 15454E-SFP-200, 15454-SFP-GEFC-SX, 15454E-SFP-GEFC-S, 15454-SFP-GE+-LX, and 15454E-SFP-GE+-LX. See the “4.2.7 SFP Modules” section on page 4-81 the document titled “Installing GBIC, SFP and XFP Optics Modules in Cisco ONS 15454, 15327, 15600, and 15310 Platforms” for more details and specifications.
- Environmental
 - Operating temperature: –5 to +45 degrees Celsius (+23 to +113 degrees Fahrenheit)
 - Operating humidity: 5 to 95%, noncondensing
 - Power consumption: 35.00 W, 0.73 A at –48 V, 119.5 BTU/hr
- Dimensions
 - Height: 12.650 in. (321.3 mm)
 - Width: 0.716 in. (18.2 mm)
 - Depth: 9.000 in. (228.6 mm)
 - Depth with backplane connector: 9.250 in. (235 mm)
 - Weight not including clam shell: 3.1 lb (1.3 kg)
- Compliance
 - For compliance information, refer to the *Cisco Optical Transport Products Safety and Compliance Information*.

4.2.5 Transponder and Muxponder Jitter Considerations

Jitter introduced by the SFPs used in the transponders and muxponders must be considered when cascading several cards. In the case of the TXP_MR_2.5G and TXPP_MR_2.5G cards, several transponders may be cascaded before the cumulative jitter violates the jitter specification. The recommended limit is 20 cards.

In the case of the TXP_MR_10G cards, you may also cascade several cards, although the recommended limit is 12 cards.

In the case of the MXP_2.5G_10G cards, any number of cards may be cascaded as long as the maximum reach between any two is not exceeded. This is because any time the signal is demultiplexed, the jitter is eliminated as a limiting factor.

4.2.6 Transponder and Muxponder Termination Modes

DWDM transponder and muxponder cards have various SONET termination modes that can be configured using CTC. The termination modes are summarized in [Table 4-27](#).

Table 4-27 DWDM Transponder and Muxponder Termination Modes

Card	Termination Modes	Description
TXP_MR_2.5G, TXPP_MR_2.5G, and TXP_MR_10G	Transparent Termination	All the bytes of the payload pass transparently through the cards.
	Section Termination	The SONET Transport Overhead (TOH) section bytes are terminated. None of these section overhead bytes are passed through. They are all regenerated, including the SONET TOH section data communication channel (DCC) bytes. In the section termination mode, the SONET TOH line overhead bytes are passed transparently.
	Line Termination	In the line termination mode, the section and line overhead bytes for SONET are terminated. None of the overhead bytes are passed through. They are all regenerated, including the SONET SDCC and line data communication channel (LDCC) bytes.
MXP_2.5G_10G ¹	Transparent Termination	All of the client bytes pass transparently through except the following: B1 is rebuilt, S1 is rewritten, A1–A2 are regenerated, and H1–H3 are regenerated.
	Section Termination	The SONET TOH section bytes are terminated. None of these section overhead bytes are passed through. They are all regenerated, including the SONET TOH section DCC bytes. In the section termination mode, the SONET TOH line overhead bytes are passed transparently.
	Line Termination	In the line termination mode, the section and line overhead bytes for SONET are terminated. None of the overhead bytes are passed through. They are all regenerated, including the SONET SDCC and LDCC bytes.

1. The clients operating at rates of OC48/STM16 are multiplexed into an OC192/STM64 frame before going to OTN or DWDM.

4.2.7 SFP Modules

This section describes the small-form factor pluggables (SFPs) that can be used with certain transponder and muxponder cards.

4.2.7.1 Compatibility by Card

Table 4-28 lists the transponder and muxponder cards and their compatible SFPs.



Caution

Only use SFP certified for use in Cisco Optical Networking Systems. The qualified Cisco SFP pluggable module's top assembly numbers (TANs) are provided in Table 4-28.

Table 4-28 SFP Card Compatibility

Card	Compatible SFP (Cisco Product ID)	Cisco Top Assembly Number (TAN)
MXP_2.5G_10G (ONS 15454 SONET)	15454-SFP-OC48-IR=	10-1975-01
	ONS-SE-2G-S1=	10-2017-01
TXP_MR_2.5G (ONS 15454 SONET)	15454-SFP3-1-IR=	10-1828-01
TXPP_MR_2.5G (ONS 15454 SONET)	15454E-SFP-L.1.1=	10-1828-01
	15454-SFP12-4-IR=	10-1976-01
	15454E-SFP-L.4.1=	10-1976-01
	15454-SFP-OC48-IR=	10-1975-01
	15454E-SFP-L.16.1=	10-1975-01
	ONS-SE-2G-S1=	10-2017-01
	15454-SFP-200=	10-1750-01
	15454E-SFP-200=	10-1750-01
	15454-SFP-GEFC-SX=	10-1833-01
	15454E-SFP-GEFC-S=	10-1833-02
	15454-SFP-GE+-LX=	10-1832-01
15454E-SFP-GE+-LX=	10-1832-02	

4.2.7.2 SFP Description

SFPs are integrated fiber optic transceivers that provide high-speed serial links from a port or slot to the network. Various latching mechanisms can be utilized on the SFP modules. There is no correlation between the type of latch to the model type (such as SX or LX/LH) or technology type (such as Gigabit Ethernet). See the label on the SFP for technology type and model. One type of latch available is a mylar tab as shown in Figure 4-31, a second type of latch available is an actuator/button (Figure 4-32), and a third type of latch is a bail clasp (Figure 4-33).

SFP dimensions are:

- Height 0.03 in. (8.5 mm)
- Width 0.53 in. (13.4 mm)
- Depth 2.22 in. (56.5 mm)

SFP temperature ranges for are:

- COM—commercial operating temperature range -5°C to 70°C

- EXT—extended operating temperature range -5°C to 85°C
- IND—industrial operating temperature range -40°C to 85°C

Figure 4-31 Mylar Tab SFP

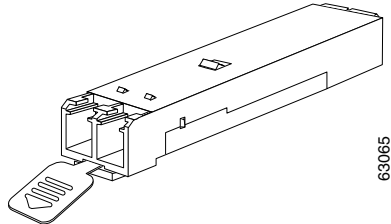

Figure 4-32 Actuator/Button SFP

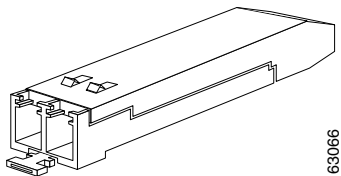
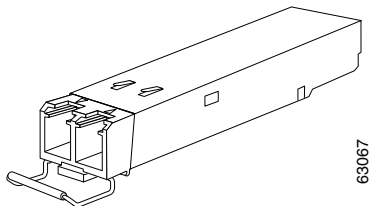

Figure 4-33 Bail Clasp SFP



4.2.7.3 Client Cabling Distances

Client cabling distances are defined in the “Installing GBIC, SFP and XFP Optics Modules in Cisco ONS 15454, 15327, 15600, and 15310 Platforms” document. If Y-cable protection is used, the maximum reach between one transponder and the other must be halved.