



Unpacking the Chassis

This chapter describes how to unpack the chassis from its shipping crate and attach a dolly before moving the chassis to its mounting location.

- [Unpacking the Cisco NCS 6000 Series Chassis](#), page 1

Unpacking the Cisco NCS 6000 Series Chassis

The Cisco NCS 6000 Series chassis is shipped on a pallet by itself in a plywood box.

Unpack the chassis and chassis components in the following order:

- Chassis
- Power system
- Exterior cosmetic components
- Cards



Note

Unpack the chassis and dolly lifting device before all other component shipping boxes. Leave all other component shipping boxes in the receiving area or in an area, as space allows, at your site, until the chassis is secured in its final location.

The following table lists the physical characteristics of the Cisco NCS 6000 Series chassis shipping crate.

Table 1: Shipping Crate and Pallet Weight and Dimensions

Weight (estimated maximum)	<p>LCC:</p> <ul style="list-style-type: none"> • 775 lb (352 kg) chassis as shipped • 1025 lb (465 kg) shipping crate with pallet • 1450 lb (658 kg) chassis fully loaded with power, fan trays, cards, and cosmetics <p>FCC:</p> <ul style="list-style-type: none"> • 708 lb (321 kg) chassis as shipped. • 925 lb (420 kg) shipping crate with pallet • 1130 lb (513 kg) chassis fully loaded with power, fan trays, cards, and cosmetics
Dimensions	Height: 88 in. (223.5 cm)
	Width: 40 in. (101.6 cm)
	Length: 48 in. (121.9 cm)

Required Tools and Equipment

- 3/8-inch ratchet wrench
- 9/16-inch socket
- Number-2 Phillips screwdriver
- Ladder or step platform

Steps

- Step 1** Locate a large area to accommodate and remove the chassis crate.
- Step 2** Open the four vertical latches on each side of the crate cover.
- Step 3** Unscrew the four Phillips-head screws at the bottom of the large side panel.
- Step 4** Unscrew the three Phillips-head screws on the bottom of each side of the plywood box.

Figure 1: Cisco NCS 6000 Series Chassis Crate

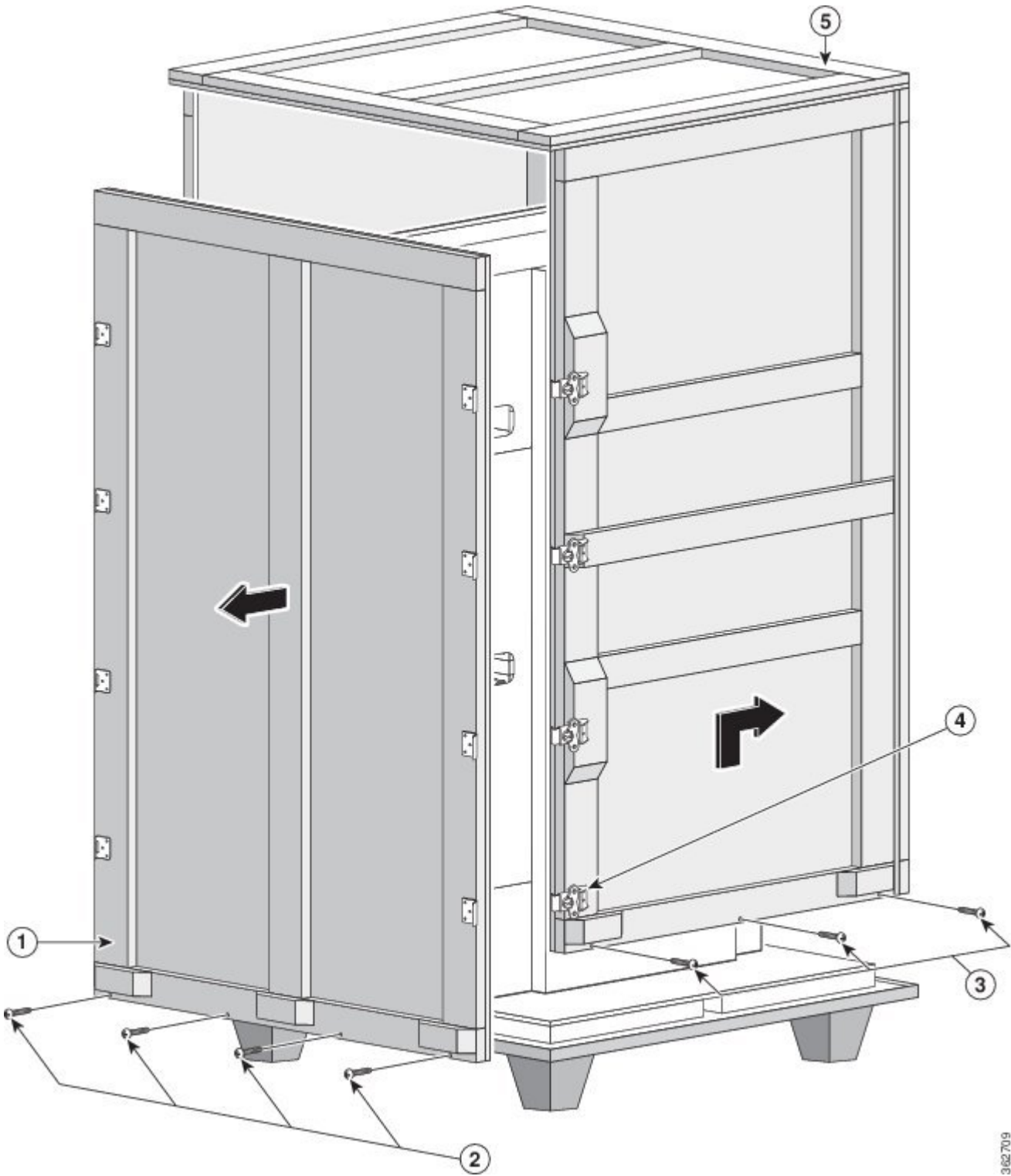

1	Large side panel	4	Vertical lock latches (four on each side)
---	------------------	---	---

382709

2	Four Phillips-head screws	5	Three-sided plywood box
3	Phillips-head screws (three on each side of plywood box)		

The drill hole template is attached to the inside of the door.

Figure 2: Drill Hole Template Attached to Inside of Crate Door

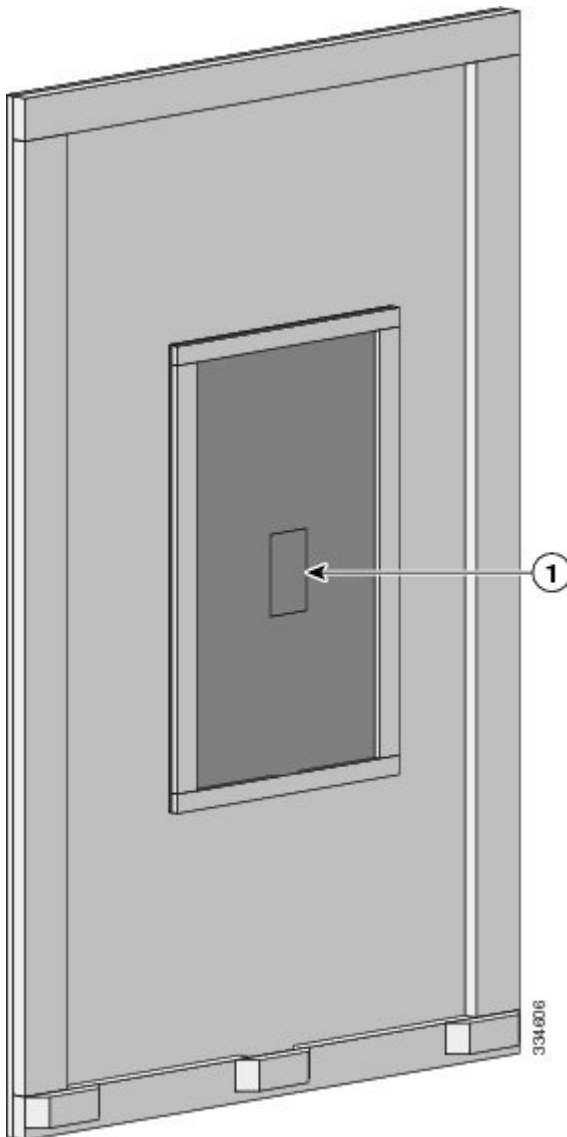

1	Drill hole template
---	---------------------

- Step 5** Remove the large side panel of the wooden enclosure and set it aside carefully.
- Note** When setting aside the box, be careful to rest the wood on the floor so that the metal lock latches are not bent or otherwise damaged. On most of the wooden enclosure, there should be rubber bands above the bottom lock latches to hold them up so that they do not get damaged when setting the enclosure down.
- Step 6** Remove the remaining bottom screws on each side of the plywood box (Figure 1: Cisco NCS 6000 Series Chassis Crate).
- Step 7** Using at least two people, one on each side of the box, lift and remove the three-sided box and place it aside.
- Step 8** Remove the protective shipping bag from the chassis. Do not remove the bag until you are ready to move and install the chassis.
- The following figure shows the wooden box removed from the chassis and its protective bag.

Figure 3: Chassis Shipping Box Removed and Chassis Shipping Bag

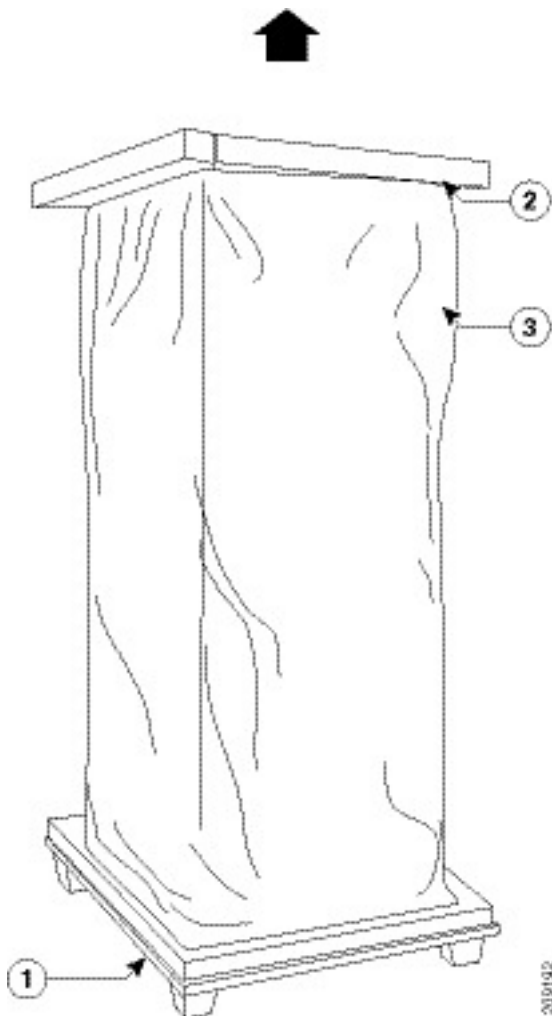

1	Chassis pallet	3	Protective bag over chassis
---	----------------	---	-----------------------------

2	Top chassis shipping cover		
---	----------------------------	--	--

Attaching the Dolly to the Chassis and Removing the Chassis Pallet

This section describes how to attach the dolly to the Cisco NCS 6000 Series chassis to remove the chassis shipping pallet and prepare to move the chassis into place. Only the 90-degree dolly configuration is used to remove the chassis from the pallet.

The following figure shows the dolly instruction label on the inside component of the dolly. Refer to this figure when performing the steps to attach the dolly to the chassis in this section.

Figure 4: Attaching the Dolly to the Chassis—Instructions

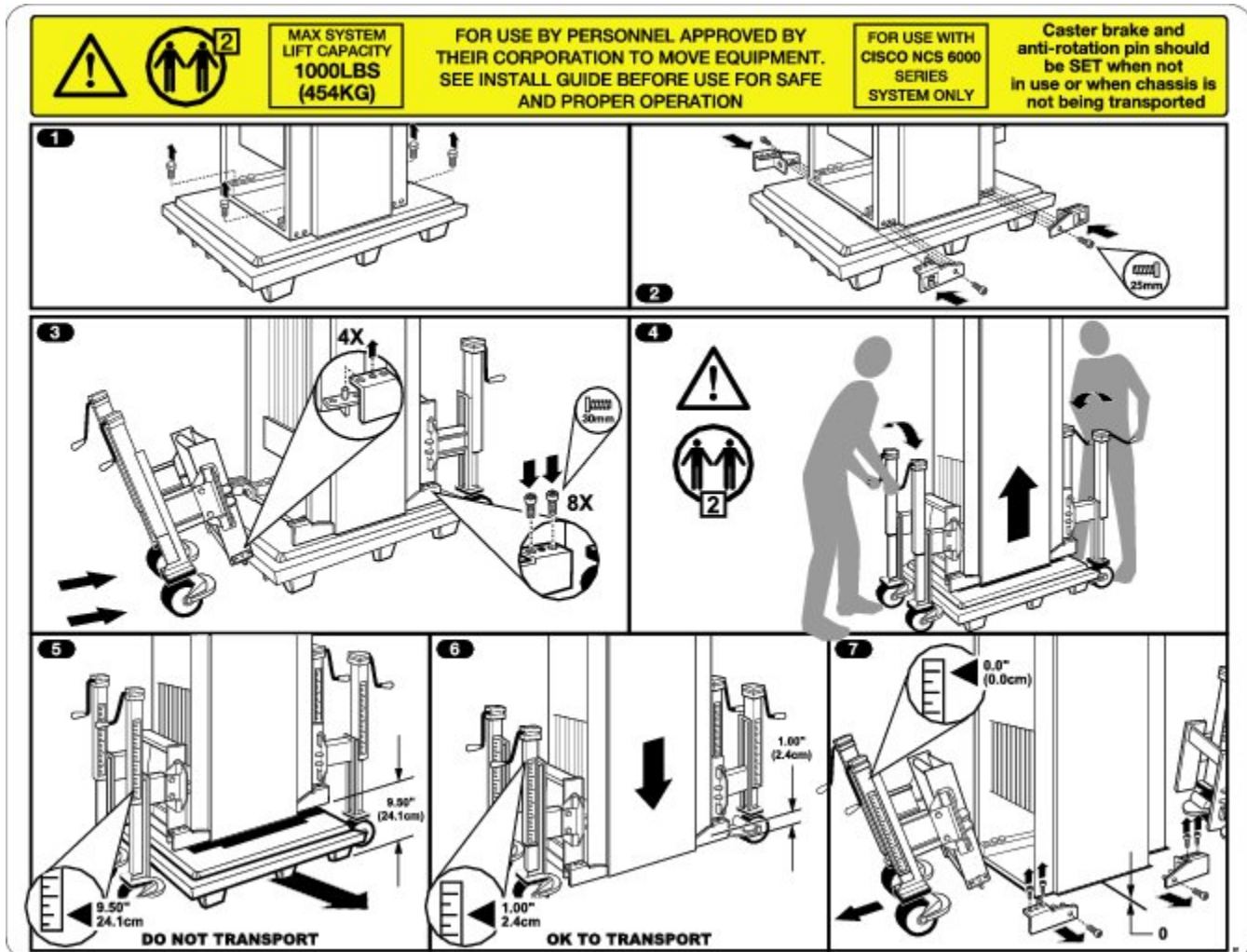

30-40815

Prerequisites

Before performing this task, unpack both the chassis and the dolly.

Required Tools and Equipment

- 3/8-inch ratchet wrench
- 9/16-mm socket
- 14-mm socket
- 12-mm hex bit

- Dolly (Cisco product ID NC-8-LIFT/B=)

Steps

- Step 1** Using the 3/8-inch ratchet wrench with 9/16-mm socket, remove the four bolts that connect the pallet to each corner of the chassis base.

Figure 5: Remove Four Bolts That Attach Pallet to the Cisco NCS 6000 Series Chassis

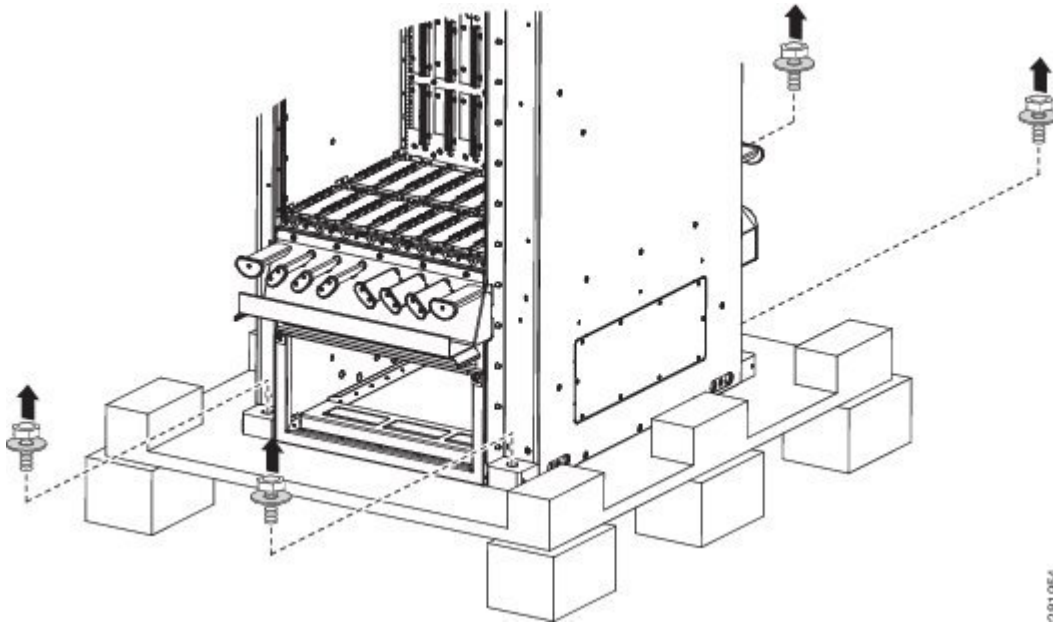

281954

Step 2 Use the 3/8-inch ratchet wrench and 9/16-mm socket to remove the two dolly-to-chassis lift brackets. Repeat this step for the second dolly unit.

Figure 6: Install Lift Brackets from Dolly

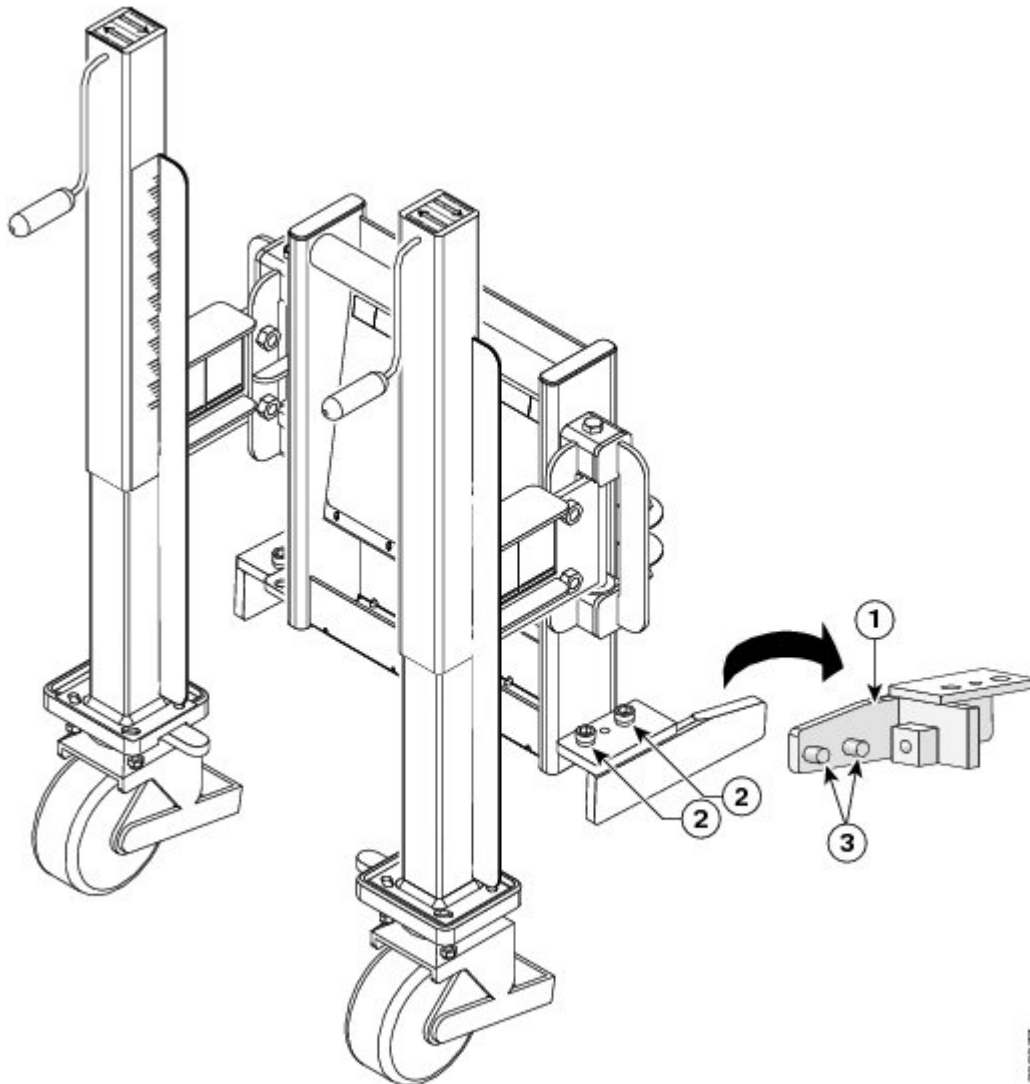

209077

1	Lift bracket	3	Two lift bracket side pins on the removed lift bracket
2	12-mm hex bit		

Note The lift brackets must be attached to the chassis first.

Step 3 Select a lift bracket. There are two identical lift brackets for the right front and left rear and two identical lift brackets for the right rear and left front.

Note The brackets are labeled as left or right (viewed from the front and rear).

Figure 7: Lift Brackets and Bolts

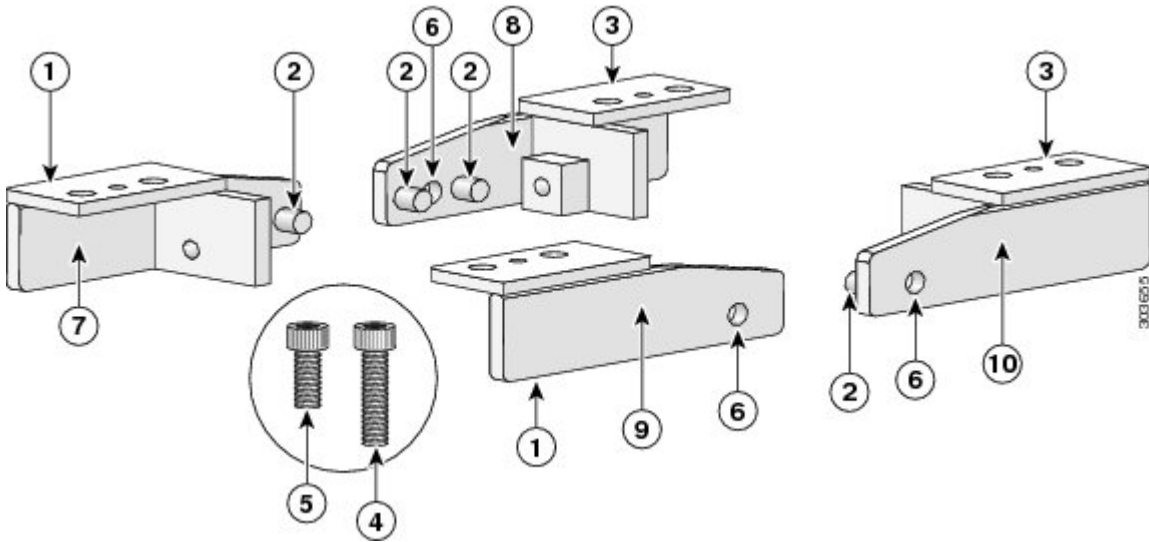

1	From left to right—left front and right front lift brackets	6	Hole for M10 x 25 mm socket-head cap screw
2	Side pins on each lift bracket (inserted into the chassis)	7	Left front
3	From left to right—right rear and left rear lift brackets	8	Right rear
4	Eight M14 x 30 mm socket-head cap screws (used to bolt the front and rear lift brackets to the dolly)	9	Right front
5	Four M10 x 25 mm socket-head cap screws (used to bolt the front and rear lift brackets to the chassis)	10	Left rear

Step 4 Attach lift brackets to the chassis by using the M10 x 25 mm bolts and 17-mm socket (Figure 7: Lift Brackets and Bolts). Align and insert the side pins of the lift bracket to the lower left side of the front side of the chassis.

Step 5 Repeat this step with the right lift bracket on the lower right side of the front side of the chassis. Figure 8: Attaching the Lift Brackets to the Chassis (Oblique View)—Cisco NCS 6008 Chassis Shown shows the oblique view of attaching the

lift brackets to the chassis. [Figure 9: Attaching the Lift Brackets to the Cisco NCS 6000 Series Chassis \(Top-Down View\)](#) shows the top-down view of attaching the lift brackets to the chassis.

Figure 8: Attaching the Lift Brackets to the Chassis (Oblique View)—Cisco NCS 6008 Chassis Shown

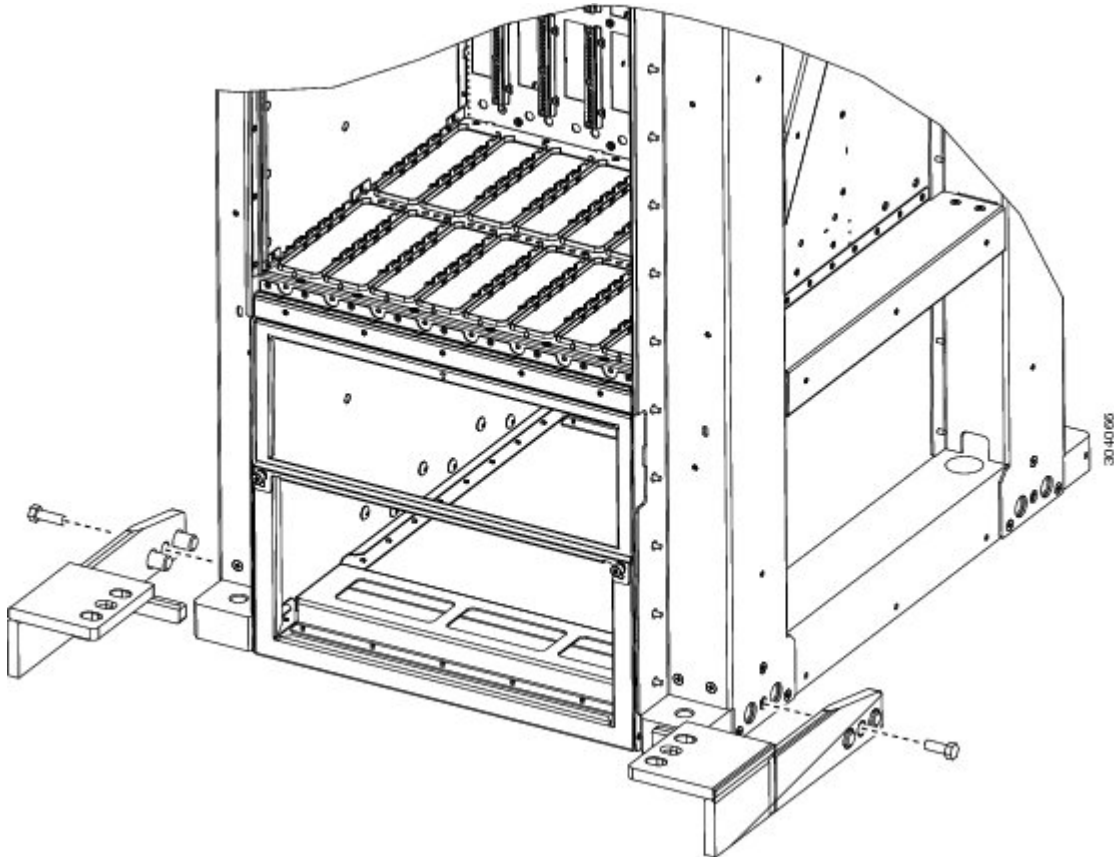
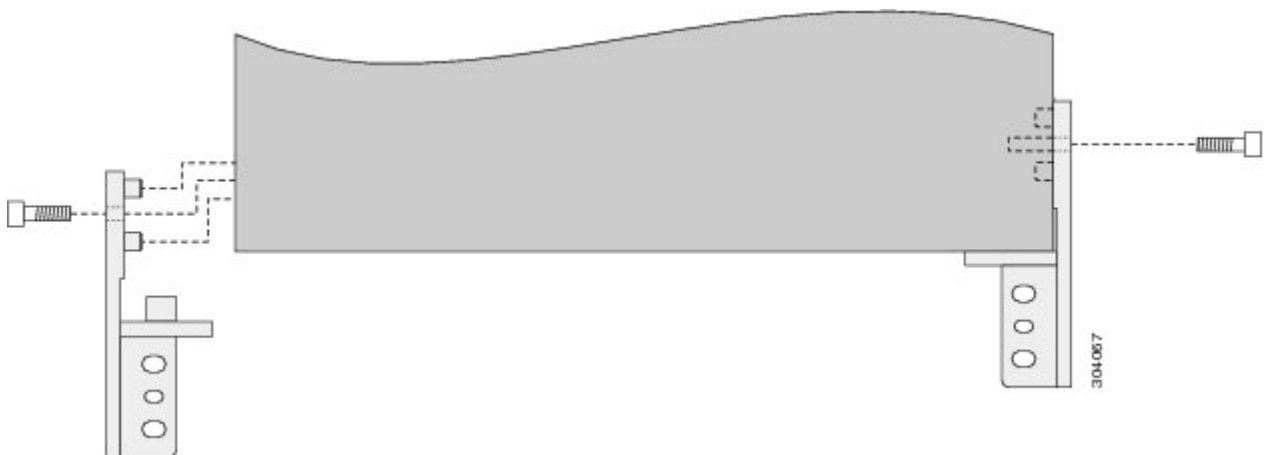

Figure 9: Attaching the Lift Brackets to the Cisco NCS 6000 Series Chassis (Top-Down View)



Step 6 Repeat Step 4 for the rear side of the chassis.

Step 7 Attach the lift brackets to the dolly by using the M14 x 30 mm bolts and 12-mm hex bit (Figure 7: Lift Brackets and Bolts).

Step 8 If the dolly caster brakes are locked, then release them and slide the dolly towards the lift brackets on the chassis (Figure 10: Sliding the Dolly to the Lift Brackets) so that the pins on the upper side of the unit align with the holes on the lift brackets. The dolly and lift brackets must align with each other to easily insert the bolts and secure the dolly to the lift brackets. Using two people, crank the dolly up (Figure 11: Adjusting the Height of the Dolly).

Note To make aligning easier, as you slide the dolly, tilt it as needed.

Figure 10: Sliding the Dolly to the Lift Brackets

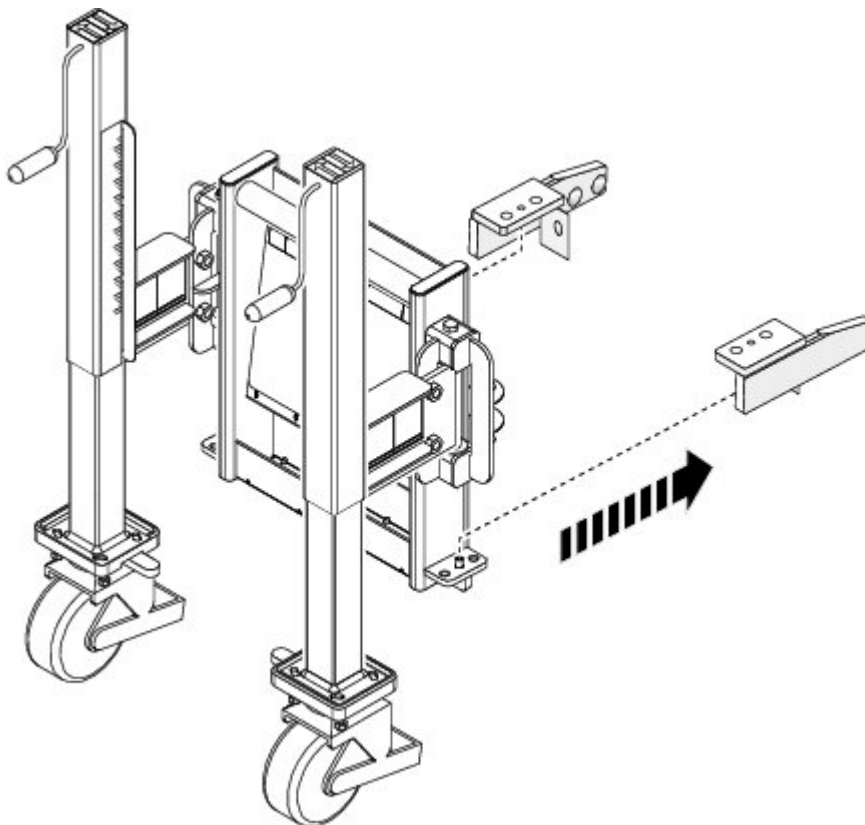

390407

Step 9 After all bolts are secured, remove the chassis pallet following these steps:

- Using two people (one person working on each dolly unit), turn the two lifting cranks to lift the chassis about 3/4 of an inch above the pallet (Figure 11: Adjusting the Height of the Dolly).

Note One person on each side of the dolly should raise the chassis enough to cleanly remove the base pallet.

Figure 11: Adjusting the Height of the Dolly

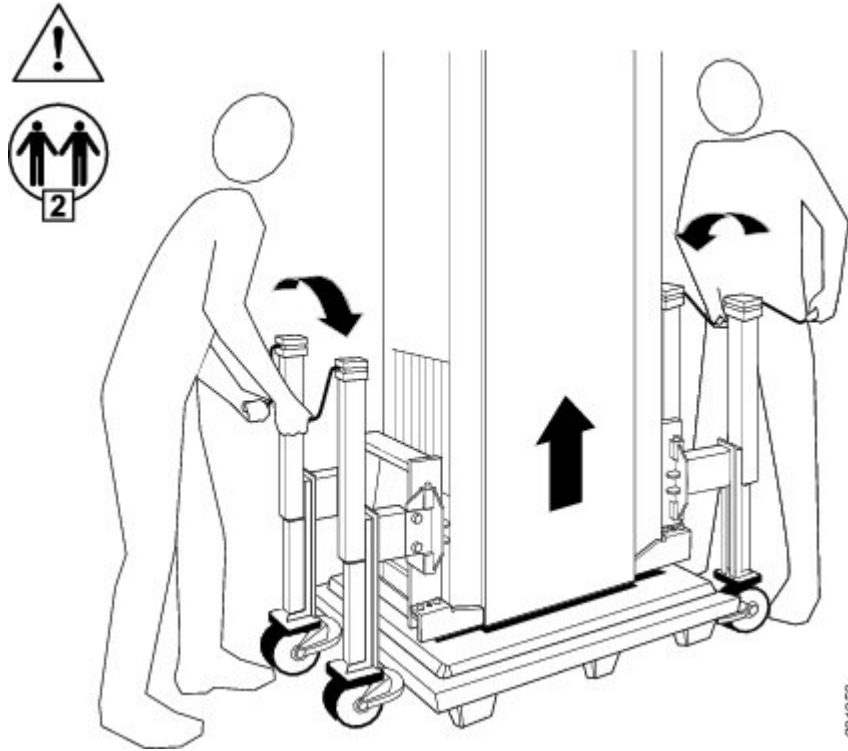

- b) Slide the pallet from under the chassis.

Figure 12: Slide Pallet From Under the Chassis

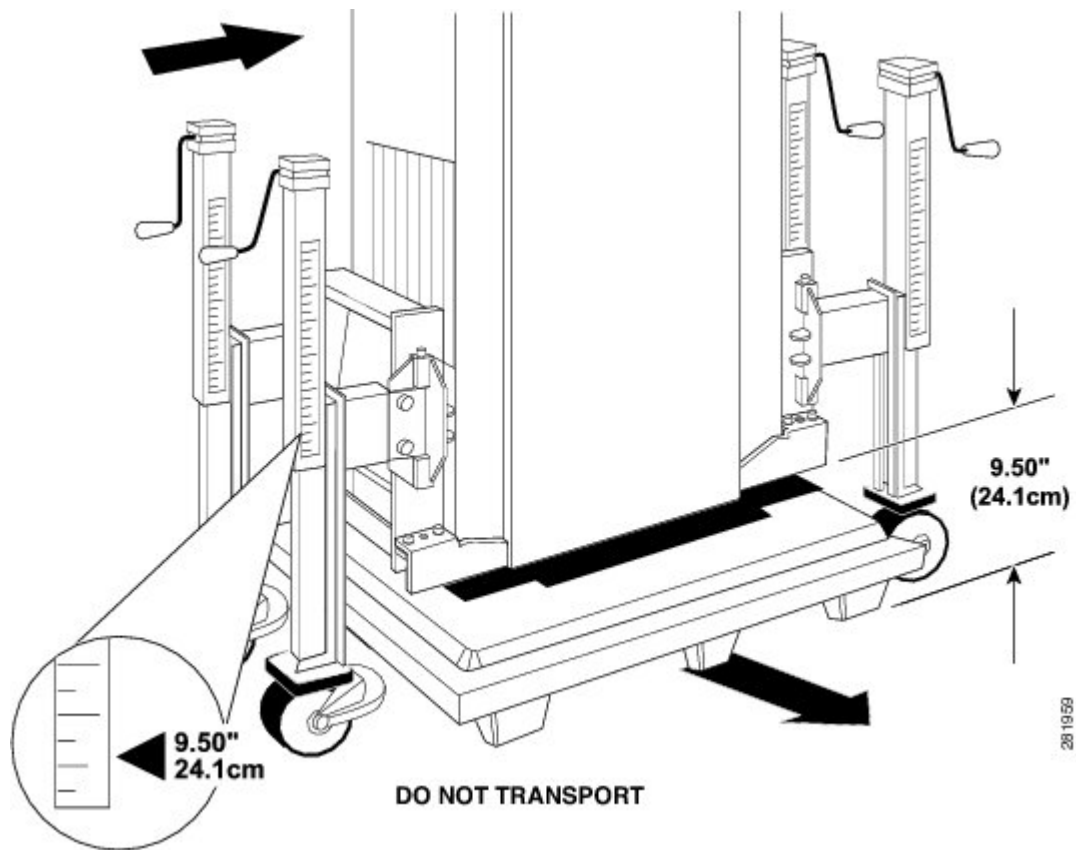

- c) Using two people (one person working on each dolly unit), lower the chassis to within 1 inch of the floor. See the height label on the dolly lift wheel assembly.

Figure 13: Lowering the Chassis

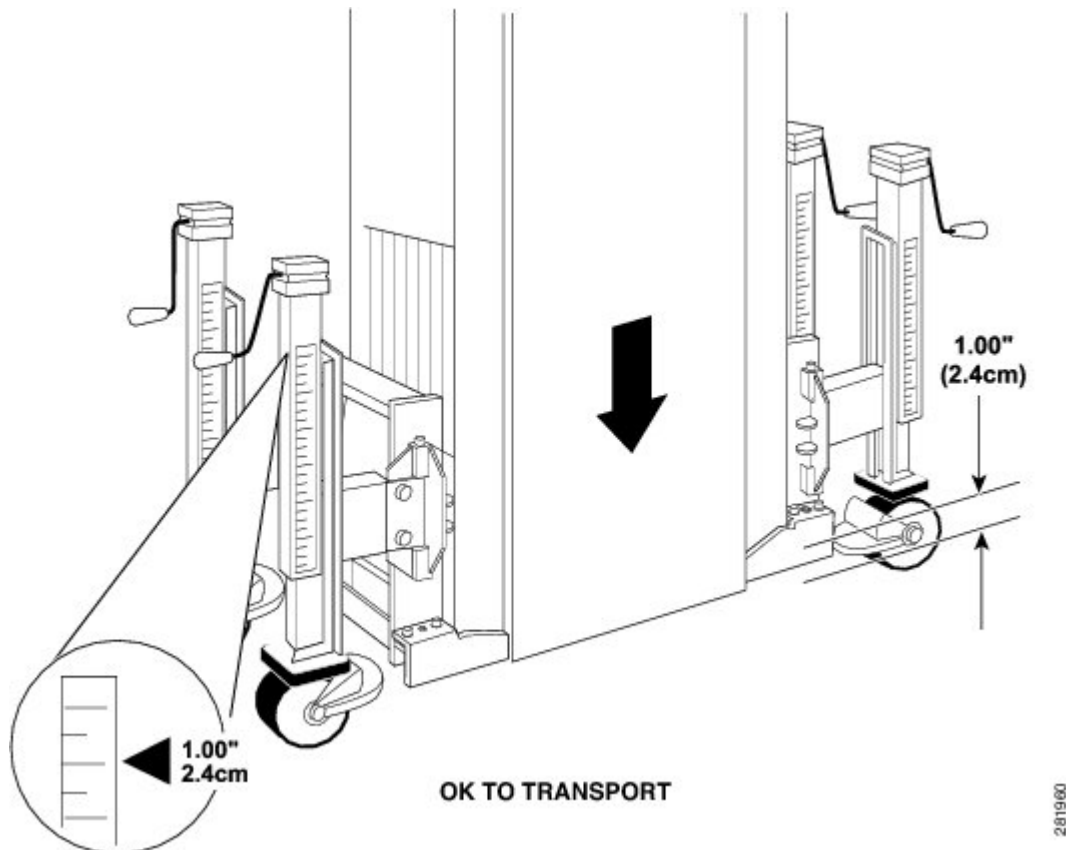

- d) Depending on the transport route and the moving space requirements at your site, the dolly can be used to move the chassis in the 90-degree or 180-degree configuration. The 180-degree position is the recommended configuration for moving the chassis.

Warning To reduce the risk of dolly instability, chassis damage, or personal injury, do not raise the equipment more than 1 inch (2.4 cm) above the floor during transportation. Statement 358