



## Install the Device

Before you begin this task, ensure that you have read and understood the safety warnings in the *Standard Warning Statements* section of the *Safety Warnings* handout.

Installing the Cisco NCS 540 Small Density routers involves these tasks:



**Note** All the installation instructions for N540X-6Z18G-SYS-A/D, N540X-8Z16G-SYS-A/D, and N540X-4Z14G2Q-A/D variants remain similar and any differences between the routers are specifically called out.

The illustrations are for reference purpose only and may vary based on your Cisco NCS 540 variant.

- [Rack Compatibility](#), on page 1
- [Set up Device on Rack or Wall](#), on page 3

## Rack Compatibility

We recommend that you follow these rack specifications.

## Rack Types

**Figure 1: Rack specification EIA (19 inches and 23 inches)**

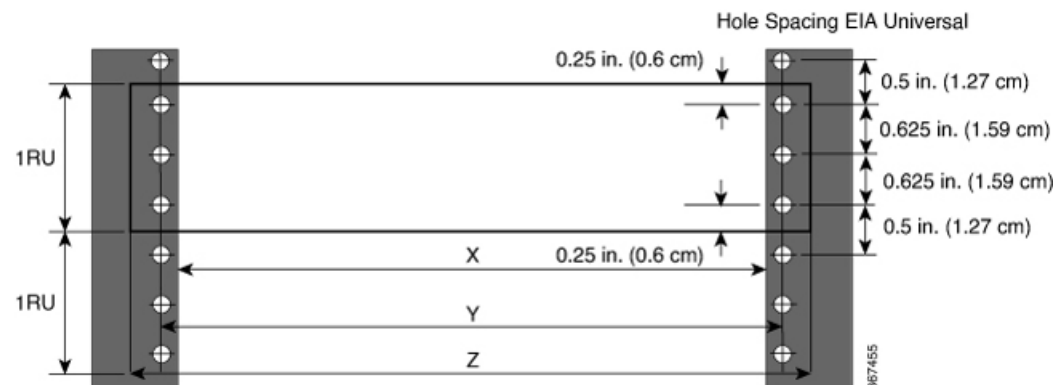
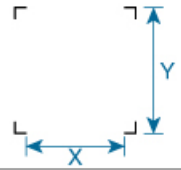
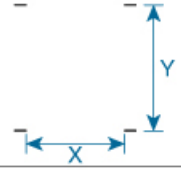
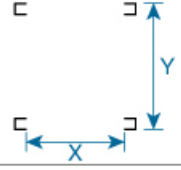

Table 1: Rack specification EIA (19 inches and 23 inches)





Post Type	Rack Type	Rack Front Opening (X)	Rack Mounting Hole Centre-Centre (Y)	Mounting Flange Dimension (Z)
4 Post	19 inches (48.3 centimeters)	17.75 inches (45 centimeters)	18.31 inches (46.5 centimeters)	19 inches (48.2 centimeters)
2 Post				
4 Post	23 inches (58.4 centimeters)	21.75 inches (55.24 centimeters)	22.31 inches (56.6 centimeters)	23 inches (58.4 centimeters)
2 Post				

Figure 2: Four Post Rack Type

4 – Post Type (Hole EIA Universal)		Width Available (X)	Compatibility
All 23" Type rack		552.45mm (21.75")	Yes
All ETSI rack (21" rack)		500.0mm (19.68")	Yes
19" Type rack L-Type Post		17.75" (450.8 mm)	Yes
		17.50" (444.5 mm)	No
19" Type Racks Flat-Post		17.75" (450.8 mm)	Yes
		17.50" (444.5 mm)	No
19" Type racks C- Type Post		17.75" (450.8 mm)	Yes
		17.50" (444.5 mm)	No

367456

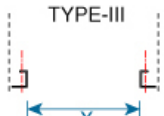
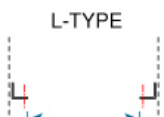
Figure 3: Two Post Rack Type

2 – Post Type (Hole EIA Universal)	X – 19" Rack	Compatibility	X-23" Rack	Compatibility
 <p>TYPE-I</p>	17.75" (450.8 mm)	Yes	21.75" (552.45mm)	Yes
	17.50" (444.5 mm)	No	21.75" (552.45mm)	Yes
 <p>TYPE-II</p>	17.75" (450.8 mm)	Yes	21.75" (552.45mm)	Yes
	17.50" (444.5 mm)	No	21.75" (552.45mm)	Yes
 <p>TYPE-III</p>	17.75" (450.8 mm)	Yes	21.75" (552.45mm)	Yes
	17.50" (444.5 mm)	No	21.75" (552.45mm)	Yes
 <p>L-TYPE</p>	17.75" (450.8 mm)	Yes	21.75" (552.45mm)	Yes
	17.50" (444.5 mm)	No	21.75" (552.45mm)	Yes
 <p>Uneven-TYPE</p>	17.75" (450.8 mm)	Yes	21.75" (552.45mm)	Yes
	17.50" (444.5 mm)	No	21.75" (552.45mm)	Yes

367457

## Set up Device on Rack or Wall

You can choose to either set up the Cisco NCS 540 on a rack or wall mount it.

### Rack Mount

The device is shipped with rack mounting brackets that are to be secured on the sides of the device.



**Caution** If the rack is on wheels, ensure that the brakes are engaged or the rack is otherwise stabilized.

Table 2: Cisco NCS 540 Small Density Router Rack-Mount Kit

Quantity	Part Description
2	Rack-mount brackets
8 (48-101850-01)	M3 x 0.5 x 6-mm Phillips flat-head screws
2 (48-101620-01)	SCR, M, PAN, PH, SEX, 10-32 x 0.365"L, CSwZN, nickel alloy

Quantity	Part Description
1 (32-0619-01)	LUG, FAST, UNIN, #6AWG, #10, 2 HOLES
4 (48-101690-01)	SCR, M, PAN, PH, 12-24 x 0.49"L, CSwZN, nickel alloy

To mount the rack on the router:

1. Attach the rack-mount brackets and the cable guides to the router as follows:
  - a. The router has port-side intake modules, position the router so that its ports are facing the cold aisle.
  - b. Position the bracket ears facing front or middle rack-mount, on the side of the chassis so that the holes are aligned.
  - c. Use four M3 screws to attach the brackets to the chassis.
  - d. Repeat Steps 1b and 1c with the other rack-mount bracket on the other side of the router.
  - e. Use four No. 12-24 screws and mount the router to the rack.

**Figure 4: Installing 19 inch Rack-Mount Brackets in the Front**

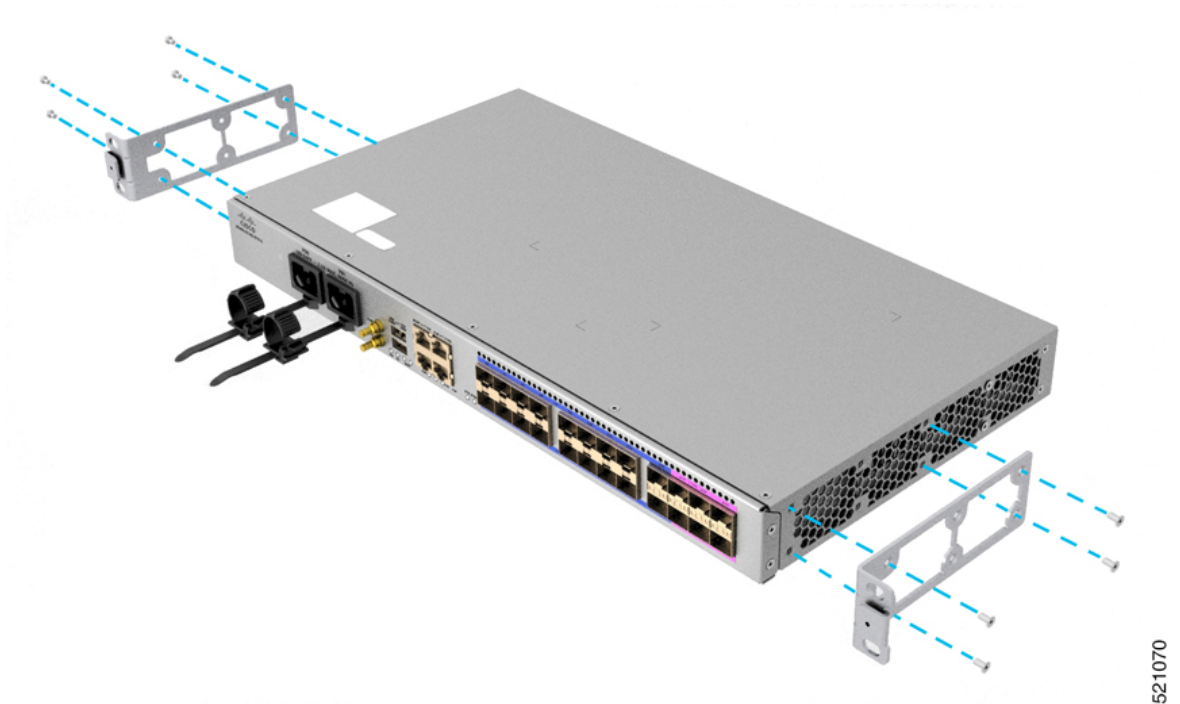

521070

**Figure 5: Installing Cable Management and 19 inch Rack-Mount Brackets in the Front**

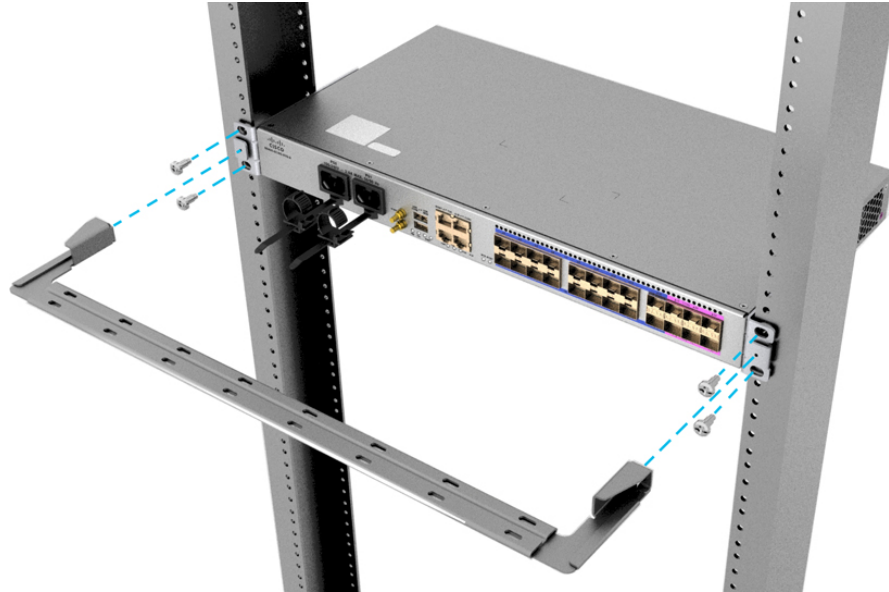

521071

**Figure 6: Installing 19 inch Rack-Mount Brackets in the Middle**

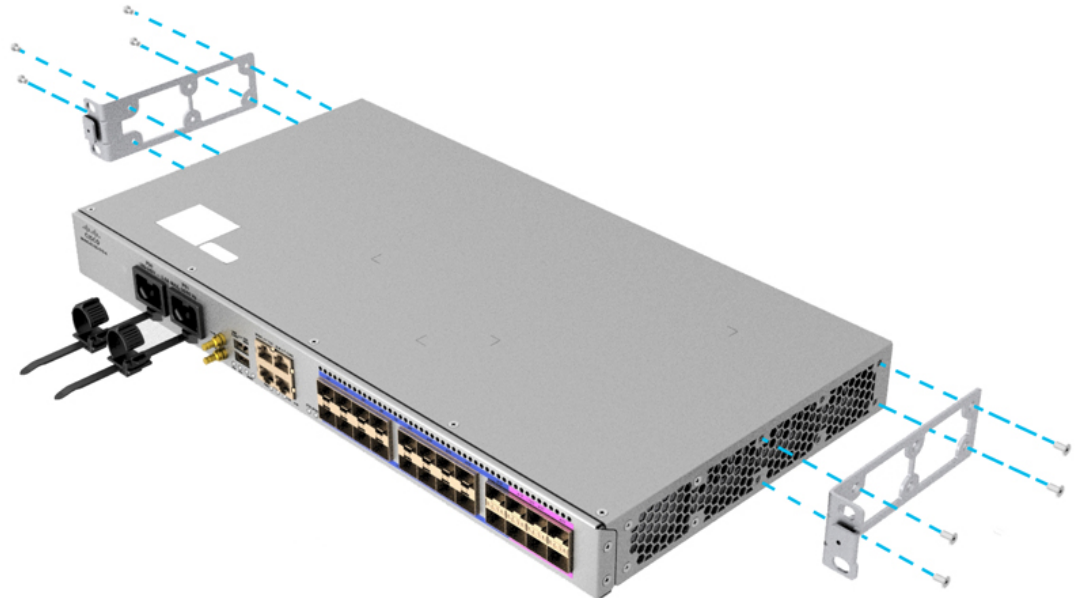

521072

**Figure 7: Installing Cable Management and 19 inch Rack-Mount Brackets in the Middle**

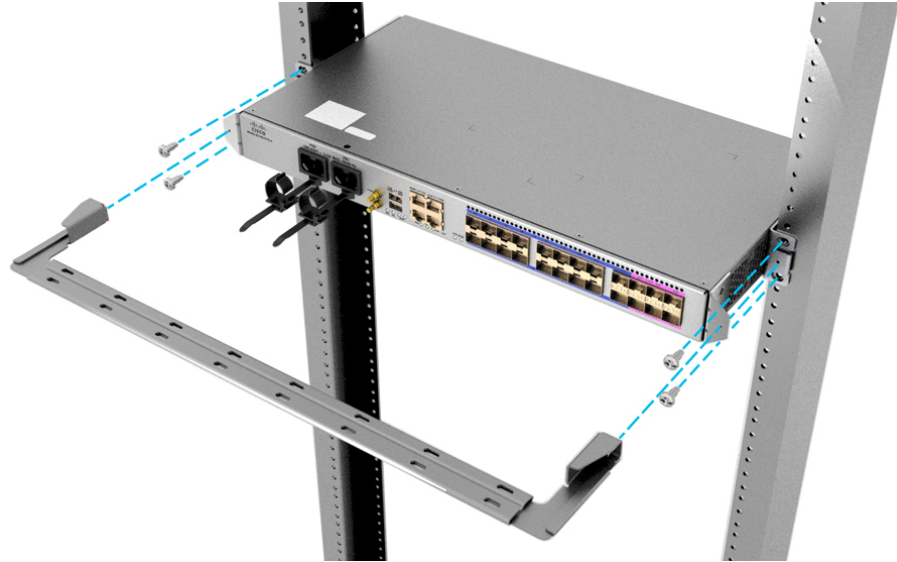

521073

**Figure 8: Installing Cable Management and 23 inch Rack-Mount Brackets in the Middle**

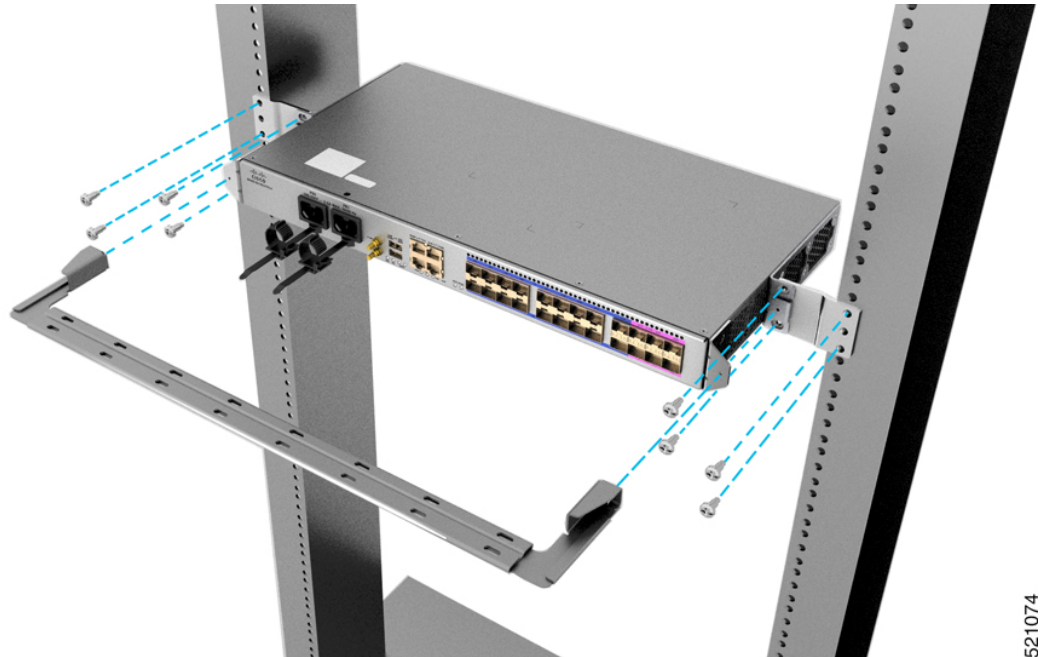

521074

**Figure 9: Installing Cable Management and 23 inch Rack-Mount Brackets in the Front**

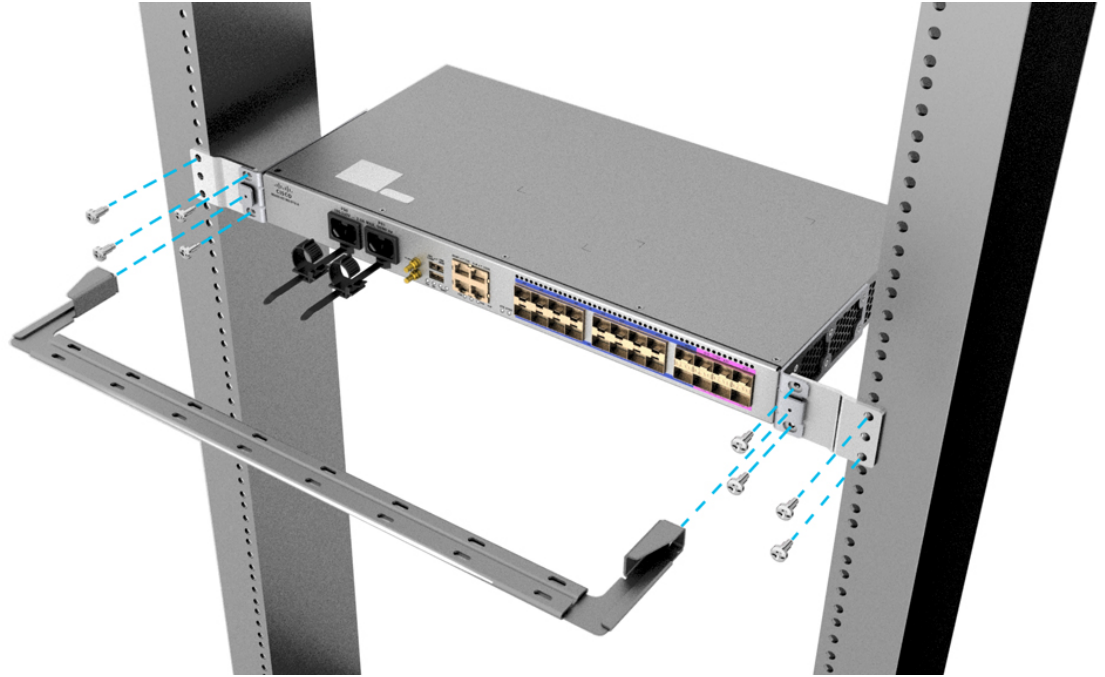

521075

**Figure 10: Installing Cable Management and ETSI Rack-Mount Brackets in the Front**

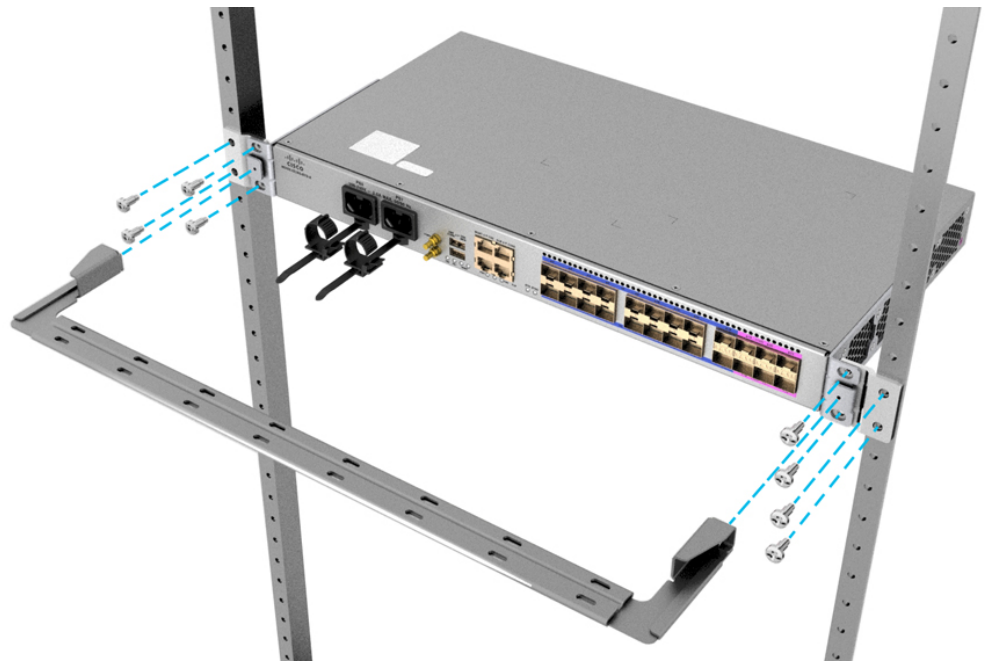

521076

**Figure 11: Installing Cable Management and ETSI Rack-Mount Brackets in the Middle**

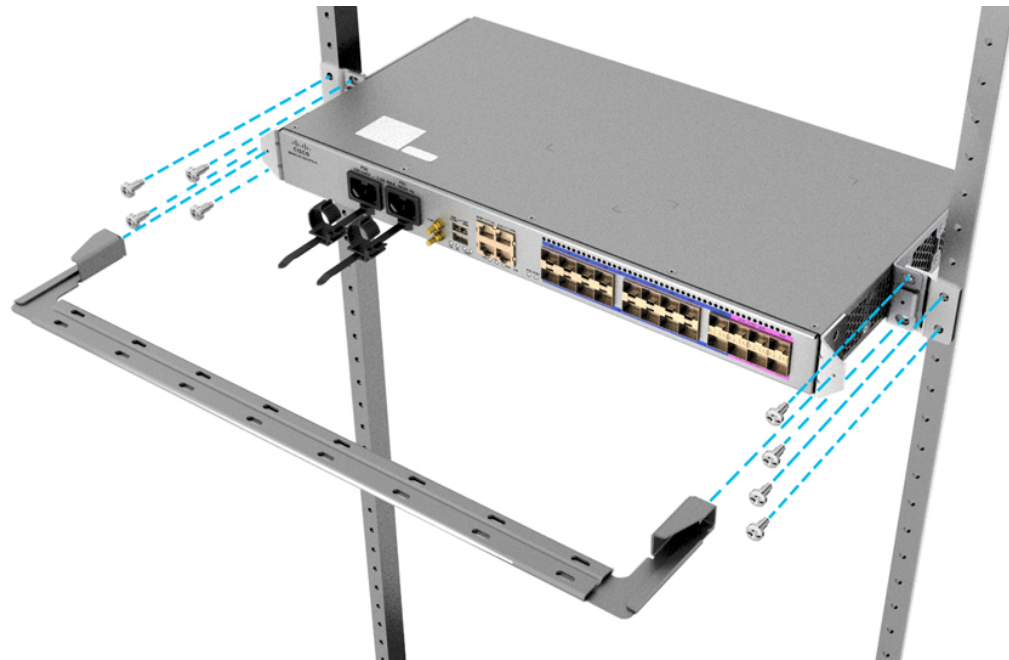

521077

2. Install the router onto the 2-post rack as follows:
  - a. Lift and position the router into position between the two rack posts.
  - b. Move the router until the rack-mount brackets come in contact with the two rack posts.
  - c. Hold the chassis at level and have another while the second person inserts two screws 12-24 in each of the two rack-mount brackets (using a total of four screws) and into the cage nuts or threaded holes in the vertical rack-mounting rails.
  - d. Tighten the 12-24 screws to 30 in-lb (3.39 N.m).

## Install the N540-6Z18G-SYS-A/D router with Air Plenum



**Note** Air plenum is only applicable for Cisco N540-6Z18G-SYS-A/D router.

### Plenum Assembly on ETSI Rack

1. Remove the screws on the sides of the chassis, according to your mounting option:
  - To front mount the chassis, remove four screws on the right side of the chassis. The "F" highlighted screws.
  - To mid mount the chassis, remove six screws on the left side of the chassis. The "F" and "R" highlighted screws.



Figure 12: Remove Screws from the Sides of the Chassis



1	Left side of the chassis
2	Right side of the chassis
3	Screw

2. Fix the plenum (800-110707-01) with help of six screws (48-101850-01).

Figure 13: Fix the Plenum with Screws

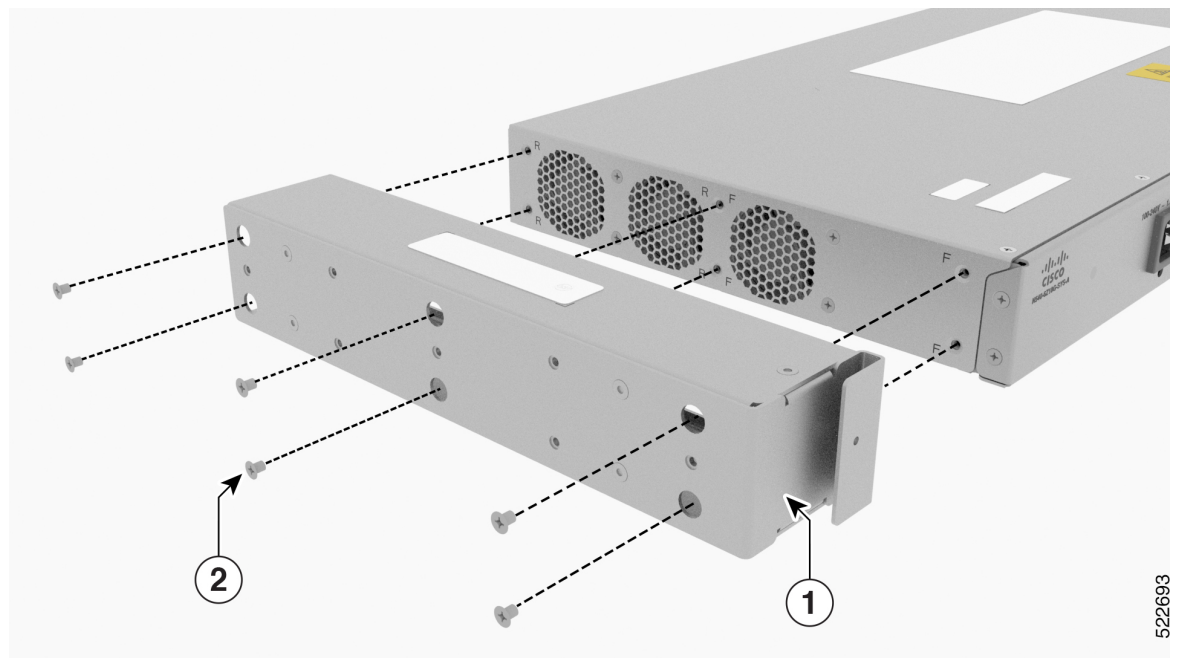

1	Air Plenum
2	Screw

3. Fix the mounting bracket (700-131329-01) with the help of four screws (48-101850-01), according to your mounting option.

- For front mount (refer image A), fix the mounting bracket in the front and the dummy cover at the rear.
- For mid mount (refer image B), fix the mounting bracket in the mid and the dummy cover at the front.

4. Fix the dummy cover (700-131330-01) with help of three screws (48-101850-01).

**Figure 14: Fix Mounting Bracket and Dummy Cover**

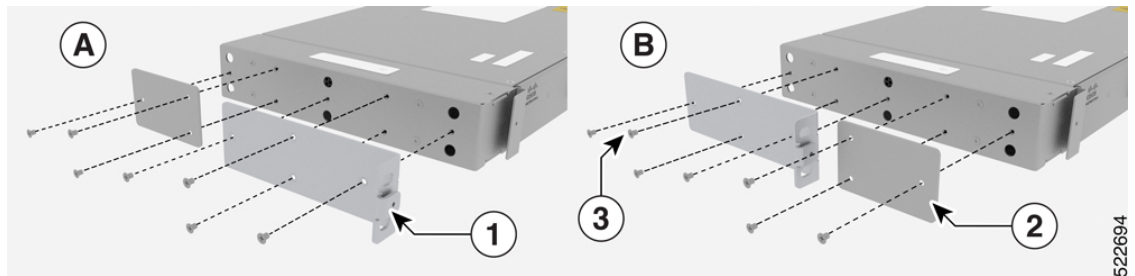

1	Mounting Bracket
2	Dummy Cover
3	Screw

5. Fix the mounting bracket (700-131271-01) with help of four screws (48-101850-01).

6. For mid mount, fix the cable bracket (700-130022-01) with help of two screws (48-101850-01). The cable bracket is applicable only in case of mid mount.

**Figure 15: Fix Mounting Bracket and Cable Bracket**

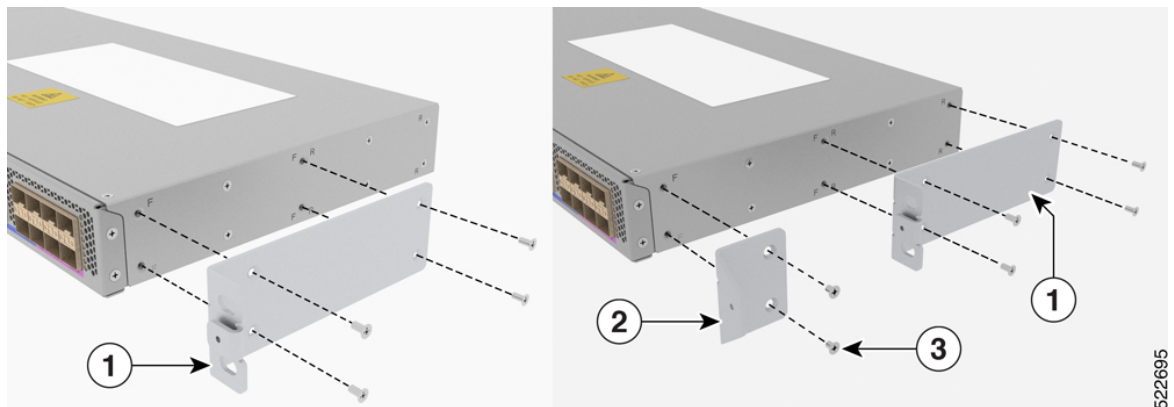

1	Mounting Bracket
2	Cable Bracket
3	Screw

7. Fix the assembly to rack either in the front or in the mid, with help of four screws (48-101690-01).

Figure 16: Fix Assembly to Rack

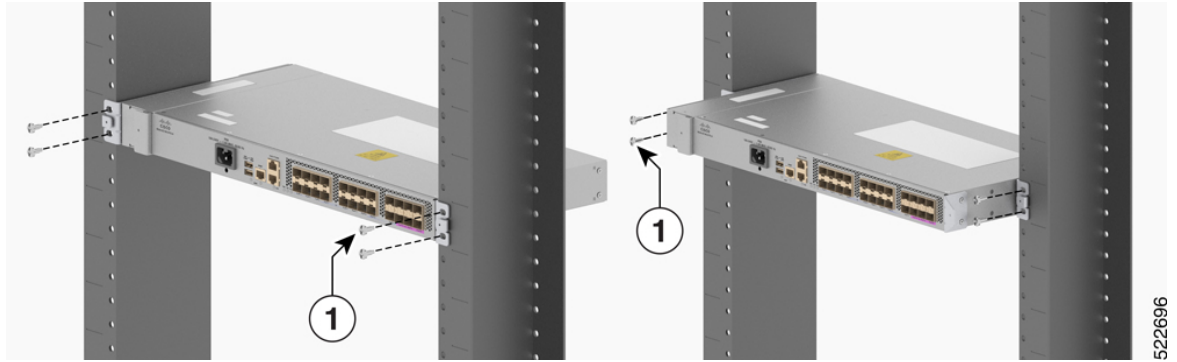

1	Screw
---	-------

8. Fix the cable bracket (700-114387-01) to the assembly with the help captive screws in the cable bracket.

Figure 17: Fix Cable Bracket to the Assembly

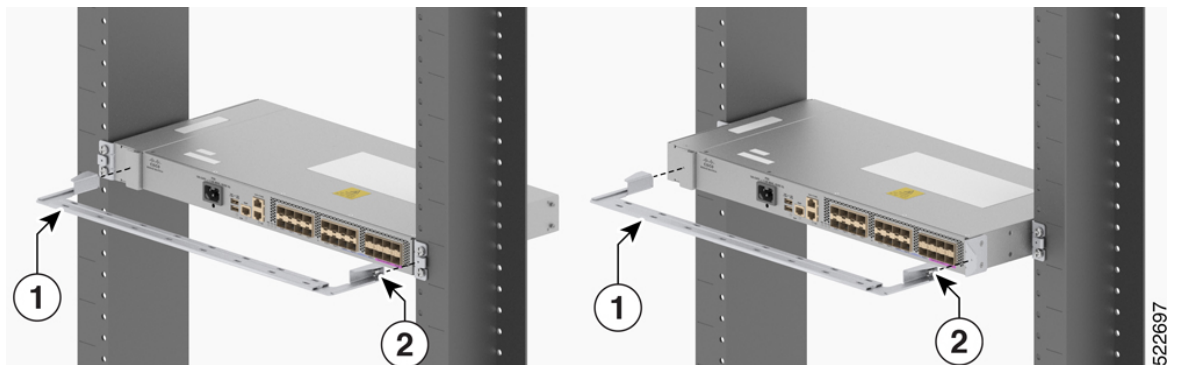

1	Cable Bracket
2	Captive Screw

Figure 18: ETSI and Air Plenum Assembly



Plenum Assembly on 23-Inches Rack

- Remove the screws on the sides of the chassis, according to your mounting option:
  - To front mount the chassis, remove four screws on the right side of the chassis. The "F" highlighted screws.
  - To mid mount the chassis, remove six screws (48-101690-01) on the left side of the chassis. The "F" and "R" highlighted screws.

**Figure 19: Remove Screws from the Sides of the Chassis**



1	Left side of the chassis
2	Right side of the chassis
3	Screw

- Fix the plenum (800-110707-01) with help of six screws (48-101850-01).

**Figure 20: Fix the Plenum with Screws**

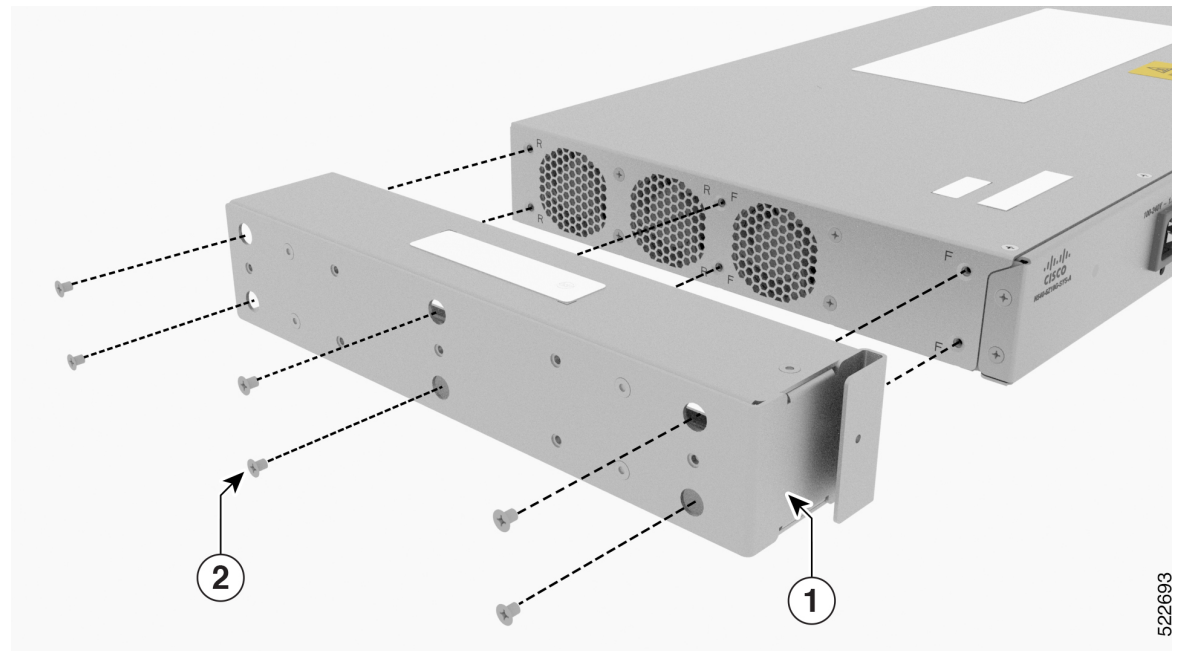

1	Air Plenum
2	Screw

3. Fix the mounting bracket (700-129948-01) with the help of four screws (48-101850-01), according to your mounting option.
  - For front mount (refer image A), fix the mounting bracket in the front and the dummy cover at the rear.
  - For mid mount (refer image B), fix the mounting bracket in the mid and the dummy cover at the front.

4. Fix the dummy cover (700-131330-01) with help of three screws (48-101850-01).

**Figure 21: Fix Mounting Bracket and Dummy Cover**

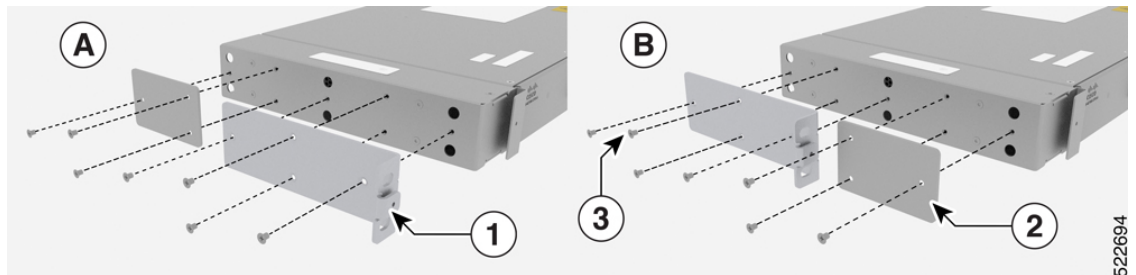

1	Mounting Bracket
2	Dummy Cover
3	Screw

5. Fix the mounting bracket (700-119499-01) with the help of four screws (48-101850-01).
6. Fix the bracket (700-112688-01) with the help of two screws (48-101690-01).
7. Fix the cable bracket (700-130022-01) with the help of two screws (48-101850-01).

**Figure 22: Fix Mounting Bracket and Cable Bracket**

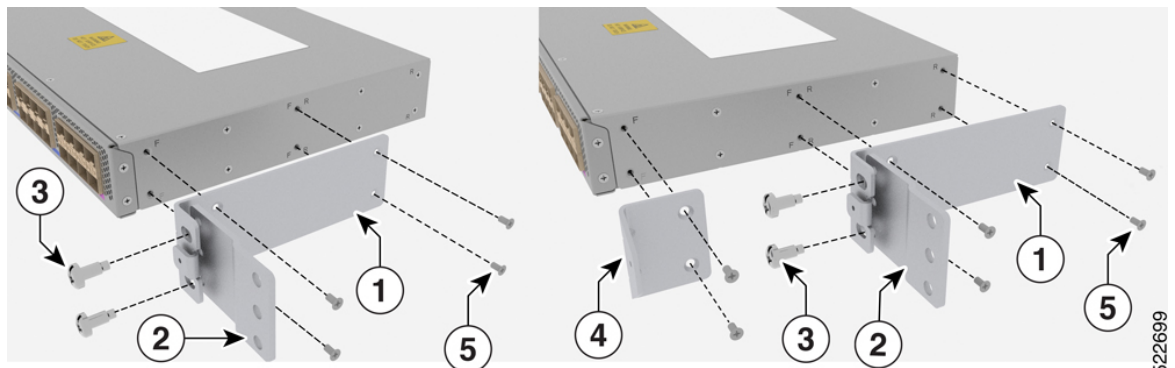

1	Mounting Bracket
---	------------------

2	Bracket
3	Bracket Screw
4	Cable Bracket
5	Mounting Bracket Screw

- Fix the assembly to rack with the help of four screws (48-101690-01).

**Figure 23: Fix the Assembly to Rack**

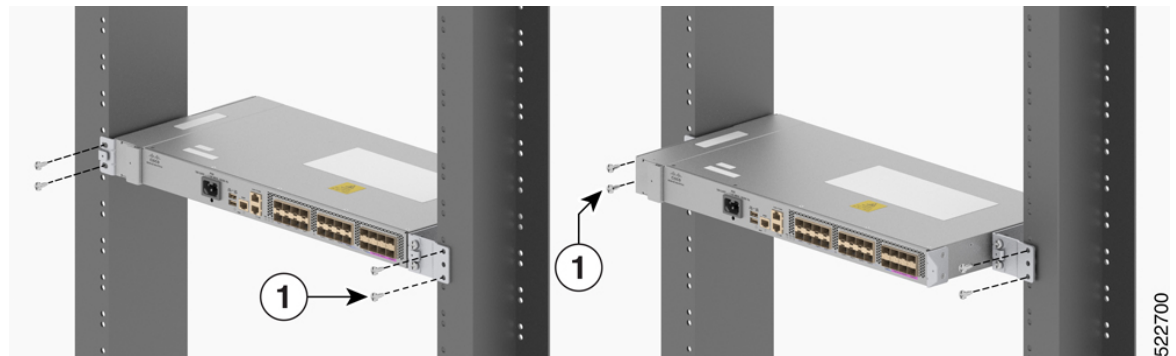

522700

1	Screw
---	-------

- Fix the cable bracket (700-114387-01) to the assembly with the help of captive screws in the cable bracket.

**Figure 24: Fix Cable Bracket to the Assembly**

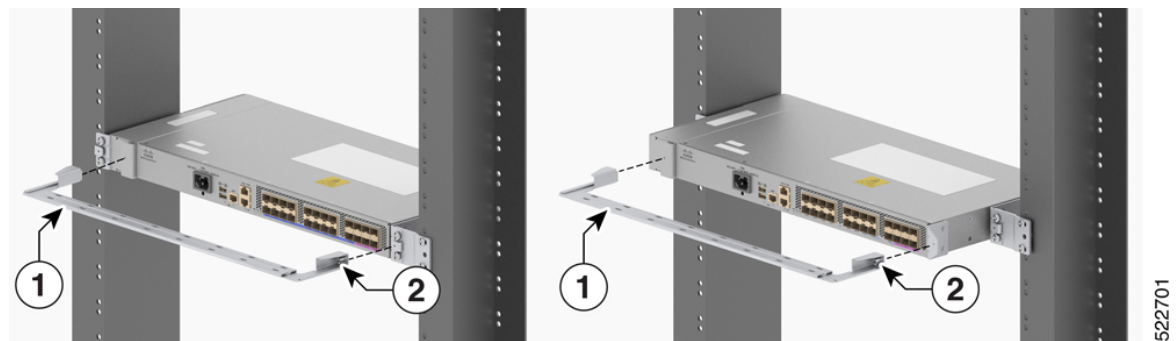

522701

1	Cable Bracket
2	Captive Screw

## Wall Mount

Install the wall mounting brackets and cable guides on to the chassis before you mount the chassis on the wall.



**Note** Wall mount is currently not available on NCS 540 Small Density Routers. Contact your Cisco representative if you need a wall mount.

## Ground the Device

Before you begin this task, ensure that you have read and understood the safety warnings in the Preventing ESD Damage section of the *Safety Warnings* handout.

Before you connect the power or turn on the power to the device, you must provide an adequate device ground (earth) connection to your device.

This section describes how to ground the device. The grounding lug location is on the back panel of the device.

To ground the device:

1. Verify that the ground cable is connected to the top of the rack and according to local site practice.

**Figure 25: Ground Lug**



2. Attach one end of the shelf ground cable (No. 6 AWG cable) to the ground point on the rear of the router using the specified dual-hole lug connector.
  - a. Use a wire-stripping tool to remove approximately 0.75 inches (19 mm) of the covering from the end of the grounding cable.
  - b. Insert the stripped end of the grounding cable into the open end of the grounding lug.
  - c. Use the crimping tool to secure the grounding cable in the grounding lug.
  - d. Remove the adhesive label from the grounding pad on the chassis.

- e. Place the grounding lug against the grounding pad so that there is solid metal-to-metal contact, and insert the two #10-32 pan head Phillips screws with washers through the holes in the grounding lug and into the grounding pad.
- f. Ensure that the lug and cable do not interfere with other equipment.
- g. Prepare the other end of the grounding cable and connect it to an appropriate grounding point in your site to ensure adequate earth ground.

## Install the AC Power Cables

To install the AC power cables in the power supply slots:

1. Plug the power supply cord in to the power supply module.
2. Wrap the tie around the power supply cord.
3. Ensure that the power supply cord is secured to the power supply module.
4. Tighten the tie around the power supply cord as shown.

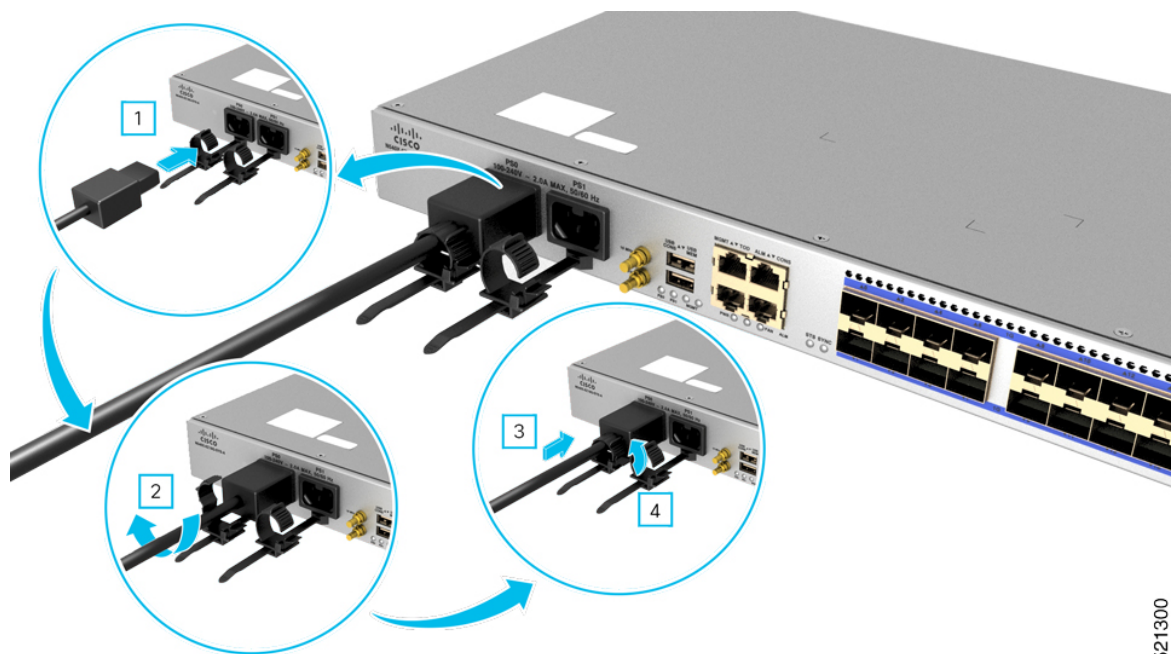

521300



**Note** These images are for only representation purposes. Certain variants of Cisco NCS 540 routers don't include a tie for the power supply cord.

## Activate an AC Power Supply Module

Perform the following procedure to activate an AC power supply:

1. Plug the power cord into the power supply.



2. Connect the other end of the power cord to an AC-input power source.
3. Verify power supply operation by checking if the respective power supply front panel LED (PS0 or PS1) is green.
4. If the LEDs indicate a power problem, see *Troubleshooting* for troubleshooting information.
5. If you are also connecting a redundant AC power supply, repeat these steps for the second power source.



**Note** If you are connecting a redundant AC power supply, ensure that each power supply is connected to a separate power source in order to prevent power loss in the event of a power failure.

The operating voltage range is 90V-265VAC, 50/60Hz.

## Install the DC Power Cables



**Note** When installing DC power supply, use 14AWG for longer cables and 14-16AWG for shorter cables, 90°C temperature rated cable. The recommended cable length is three meters maximum from source.



- Note**
- Always ensure that the building's installation for short-circuit (overcurrent) protection does not exceed 15A.
  - We recommend you to use a circuit breaker or a fast acting fuse with a maximum DC rating, based on the router variants for over current protection.

**Table 3: Main Circuit Breaker Power Ratings**

Router	DC Power Rating
<ul style="list-style-type: none"> <li>• N540X-6Z18G-SYS-D</li> <li>• N540X-8Z16G-SYS-D</li> <li>• N540X-4Z14G2Q-D</li> </ul>	10A
N540-6Z18G-SYS-D	6A

Figure 26: DC Connector with In built Screw

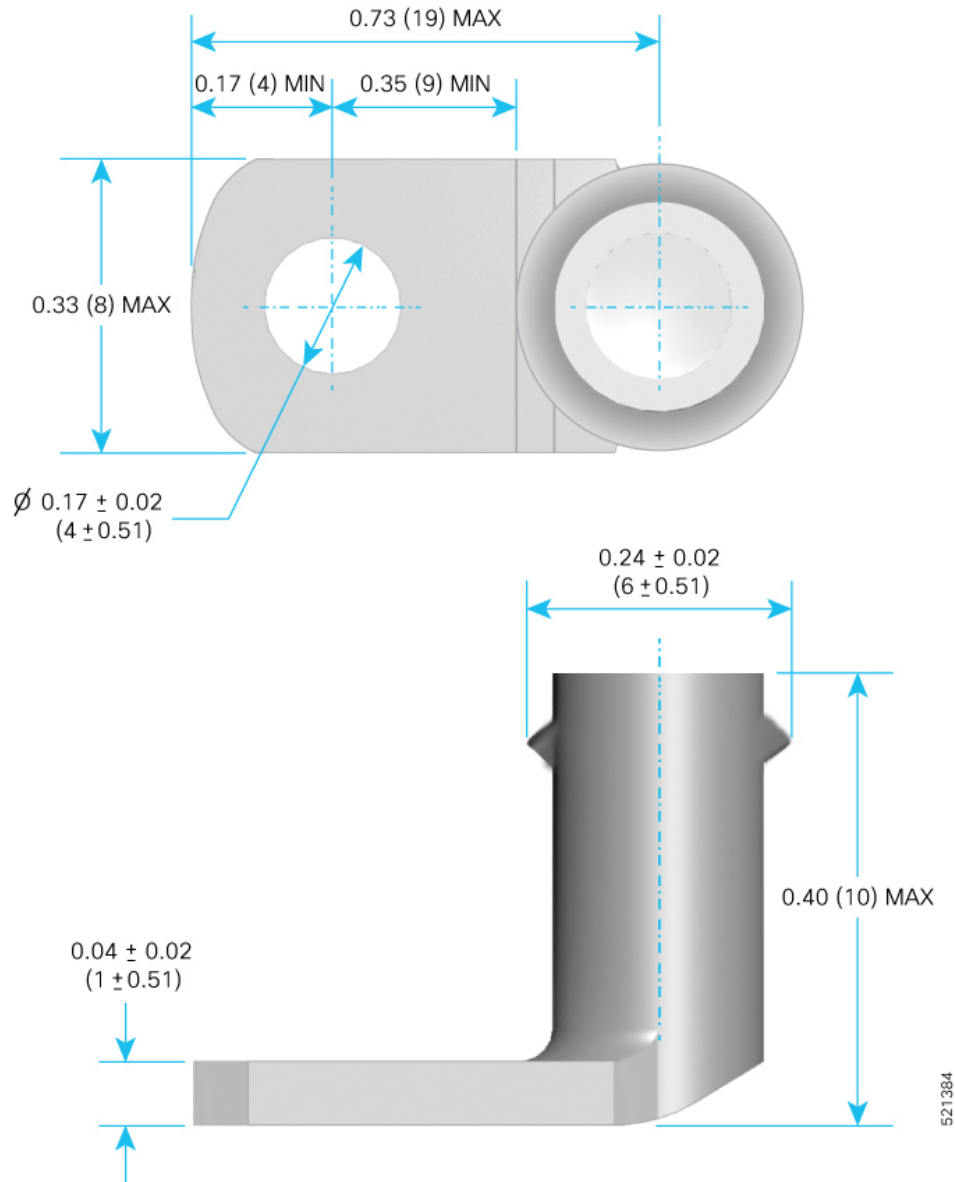

To attach the DC power supplies:

1. Locate the terminal block plug.
2. Insert the DC-input power source wires into the terminal block plug.
3. Attach the DC supply wires using the designated screws.
4. Use a ratcheting torque screwdriver to torque the terminal block plug captive screw. (See the following figure.)

Figure 27: Attach the DC Power Supply Wires

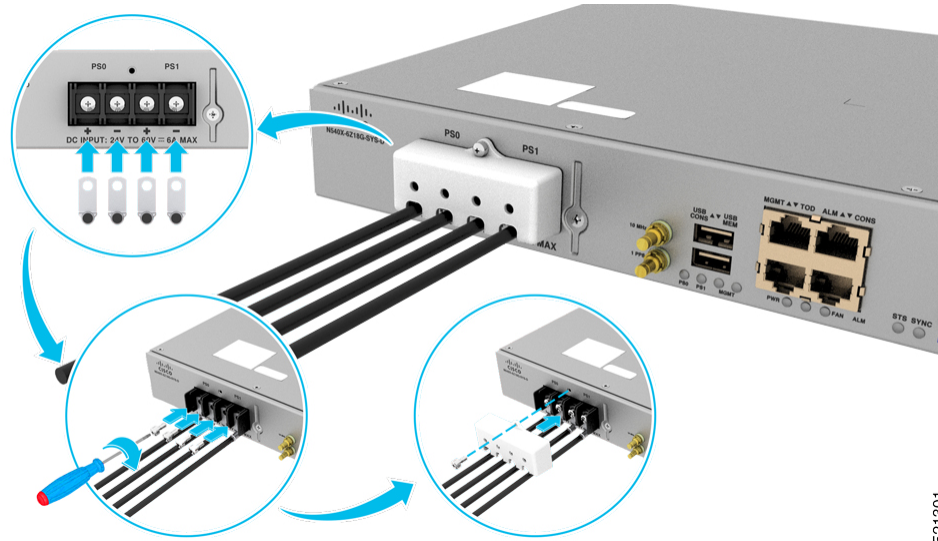

521301

## Activate a DC Power Supply Module

Perform the following procedure to activate a DC power supply:

1. Verify the power supply operation by checking whether the respective power supply front panel LED (PS0 or PS1) is green.
2. If the LEDs indicate any issues with power problem, see *Troubleshooting*.
3. If you are also connecting a redundant DC power supply, repeat these steps for the second power source.



**Note** If you are connecting a redundant DC power supply, ensure that each power supply is connected to a separate power source in order to prevent power loss in the event of a power failure.

The operating voltage range is -20V to -72VDC.

## Port Connection Guidelines

To prevent damage to the fiber-optic cables, we recommend that you keep the transceivers disconnected from their fiber-optic cables when installing the transceiver in the line card. Before removing a transceiver from the router, remove the cable from the transceiver.

To maximize the effectiveness and life of your transceivers and optical cables, do the following:

- Wear an ESD-preventative wrist strap that is connected to an earth ground whenever handling transceivers. The router is typically grounded during installation and provides an ESD port to which you can connect your wrist strap.
- Do not remove and insert a transceiver more often than is necessary. Repeated removals and insertions can shorten its useful life.

- Keep the transceivers and fiber-optic cables clean and dust free to maintain high signal accuracy and to prevent damage to the connectors. Attenuation (loss of light) is increased by contamination and should be kept below 0.35 dB.
  - Clean these parts before installation to prevent dust from scratching the fiber-optic cable ends.
  - Clean the connectors regularly; the required frequency for cleaning depends upon the environment. In addition, clean connectors when they are exposed to dust or accidentally touched. Both wet and dry cleaning techniques can be effective; refer to your site's fiber-optic connection cleaning procedures.
  - Do not touch the ends of connectors. Touching the ends can leave fingerprints and cause other contamination.
- Inspect routinely for dust and damage. If you suspect damage, clean and then inspect fiber ends under a microscope to determine if damage has occurred.



---

**Note** Keep unused ports covered with dust caps in order to protect them from dust and insects.

---

## Connect to the Console Port

### Before you begin:

- The router must be fully installed in its rack, connected to a power source, and grounded.
- The necessary cabling for the console, management, and network connections must be available.
  - An RJ-45 rollover cable and DB9F/RJ-45 adapter.
  - Network cabling should already be routed to the location of the installed router.

Before you create a network management connection for the router or connect the router to the network, you must create a local management connection through a console terminal and configure an IP address for the router. You also can use the console to perform the following functions (each of which can be performed through the management interface after you make that connection):

- Configure the router using the command-line interface (CLI).
- Monitor network statistics and errors.
- Configure Simple Network Management Protocol (SNMP) agent parameters.
- Download software updates.

The system console port is an RJ-45 receptacle for connecting a data terminal to perform the initial configuration of Cisco NCS 540 fixed-port chassis.

You can connect the router to the computer USB port using the following options:

### • Connect Using USB-A Cable

1. Use USB-A cable to connect from the USB console port (USB CONS) on the router to the USB port of the computer.

2. The settings are the following:

- Baud rate: 115200
- Data: 8
- Parity: none
- Stop bit:1

Install the required driver from the following link:

<https://www.maxlinear.com/product/interface/uarts/usb-uarts/xr21v1410>

**Figure 28: Connect Using USBA-A Cable**

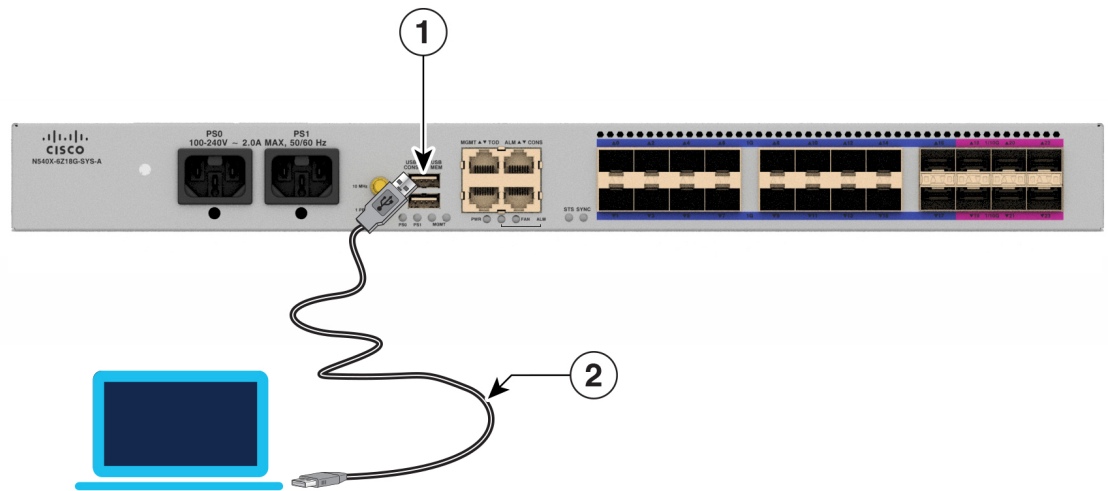

521401

1	Console Port
2	USB Type-A console cable

**• Connect Using Console Port (CONS)**

Use the console port (CONS) and the converter cable to connect the router to the computer. Use the converter cable in the following way:

1. RJ-45 to DB-9 Female Connection - Connect the RJ-45 end of the cable to the router.
2. DB-9 Male to USB - Connect the USB end to the computer.

• **Figure 29: Connecting the USB Console Cable to the Chassis**

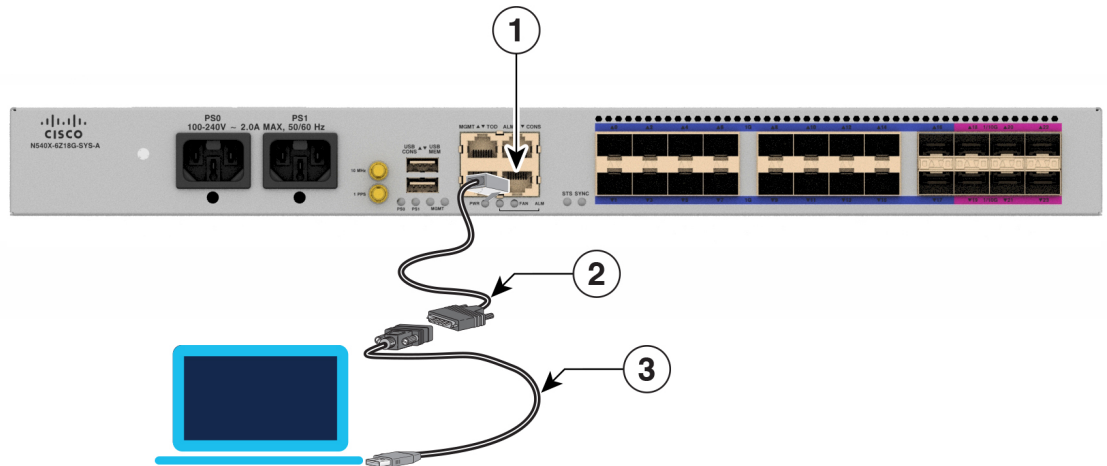

1	RJ45 Port
2	Serial to RJ45 Console Adapter Cable
3	USB to Serial Interface Cable

Following table represents the RJ-45 cable pin-out information.

**Table 4: RJ-45 Straight-through Cable Pin-outs**

RJ-45 Pin	Signal
1	—
2	—
3	Tx
4	Ground (GND)
5	GND
6	Rx
7	—
8	—

## Connect to the Management Ethernet Port

You must complete the initial router configuration.

The management Ethernet port provides out-of-band management, which enables you to use the command-line interface (CLI) to manage the router by its IP address. This port uses a 10/100/1000 Ethernet connection with an RJ-45 interface.



**Note** To prevent an IP address conflict, do not connect the management Ethernet port until the initial configuration is complete.

To connect cables to the system management port, attach Category 5 cables directly to the RJ-45 receptacle on the management Ethernet port.

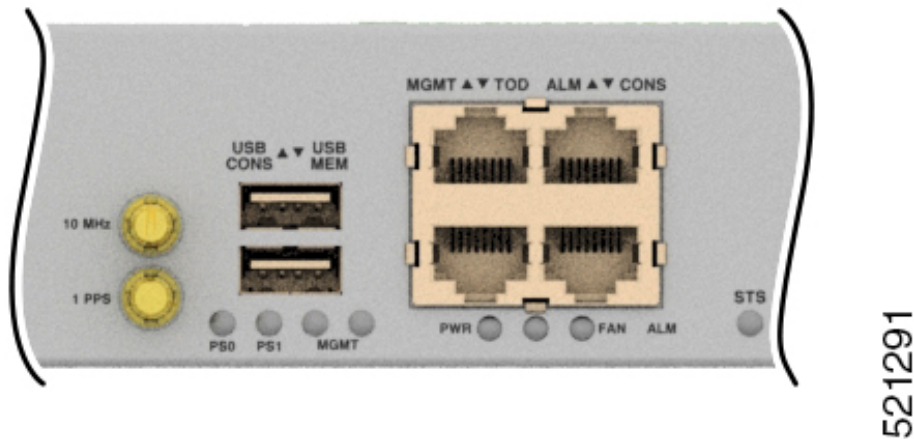

**Note** To comply with GR-1089-CORE, the intra-building port(s) of the equipment must use shielded intra-building cabling or wiring that is grounded at both ends.

- Plug the cable directly into the RJ-45 receptacle.
- Connect the network end of your RJ-45 cable to a switch, hub, repeater, or other external equipment.

## Connecting Timing Cables

The sections below describe how to connect timing cables to the Cisco NCS 540 Small Density Router.



**Note** The timing features are not applicable to Cisco N540-6Z18G-SYS-A/D router.

### Connecting Cables to a GPS Interface

The following sections describe how to connect cables from the Cisco NCS 540 Small Density router to a GPS unit for input or output timing:

#### Connecting a Cable to the Input 10-MHz or 1-PPS Interface

1. Connect one end of the mini-coax cable to the external GPS unit or any other equipment that is provided with stable 1PPS/10M reference input.

2. Connect the other end of the mini-coax cable to the 10-MHz or 1-PPS port on the front panel of the Cisco NCS 540 Small Density router.

### Connecting a Cable to the Output 10-MHz or 1-PPS Interface

1. Connect one end of the mini-coax cable to the external unit. The external unit can be measuring unit or any other unit that requires 1PPS/10M reference.
2. Connect the other end of the mini-coax cable to the 10-MHz or 1-PPS port on the front panel of the Cisco NCS 540 Small Density router, which is configured as 1588 secondary mode or boundary clock mode.

### Connecting a Cable to the ToD Interface

1. Connect one end of a straight-through Ethernet cable to the GPS unit.
2. Connect the other end of the straight-through Ethernet cable to the ToD or 1-PPS port on the router of the Cisco NCS 540 Small Density router.



#### Warning

To comply with the Telcordia GR-1089 NEBS standard for electromagnetic compatibility and safety, connect the ToD ports only to intra-building or unexposed wiring or cable. The intrabuilding cable must be shielded and the shield must be grounded at both ends. The intra-building port(s) of the equipment or subassembly must not be metalically connected to interfaces that connect to the OSP or its wiring. These interfaces are designed for use as intra-building interfaces only (Type 2 or Type 4 ports as described in GR-1089-CORE) and require isolation from the exposed OSP cabling. The addition of Primary Protectors is not sufficient protection in order to connect these interfaces metalically to OSP wiring.

## Install and Remove Transceiver Modules

### Install and Remove SFP Modules

Before you remove or install an SFP or SFP+ module, read the installation information in this section.



#### Warning

**Statement 1051**—Laser Radiation

Invisible laser radiation may be emitted from disconnected fibers or connectors. Do not stare into beams or view directly with optical instruments.



#### Caution

Protect the router by inserting a clean SFP/SFP+ module cage cover, shown in the figure below, into the optical module cage when there is no SFP or SFP+ module installed.



Figure 30: SFP/SFP+ Module Cage Cover



**Caution** Protect the SFP or SFP+ modules by inserting clean dust covers into them after the cables are removed. Be sure to clean the optic surfaces of the fiber cables before you plug them back into the optical ports of another module. Avoid getting dust and other contaminants into the optical ports of your SFP or SFP+ modules, because the optics do not work correctly when obstructed by dust.



**Caution** We strongly recommended that you do not install or remove the SFP or SFP+ module with fiber-optic cables attached to it because of the potential of damaging the cable, the cable connector, or the optical interfaces in the module. Disconnect all cables before removing or installing an SFP or SFP+ module. Removing and inserting a module can shorten its useful life; so you should not remove and insert modules more than it is absolutely necessary.



**Note** When installing an SFP or SFP+ module, you would hear a click as the triangular pin on the bottom of the module snaps into position into the hole in the receptacle. The click indicates that the module is correctly seated and secured in the receptacle. Verify that the modules are completely seated and secured in their assigned receptacles on the line card by firmly pushing on each SFP or SFP+ module.

### Bale Clasp SFP or SFP+ Module

The bale clasp SFP or SFP+ module has a clasp that you use to remove or install the module. (See the figure below.)

Figure 31: Bale Clasp SFP or SFP+ Module

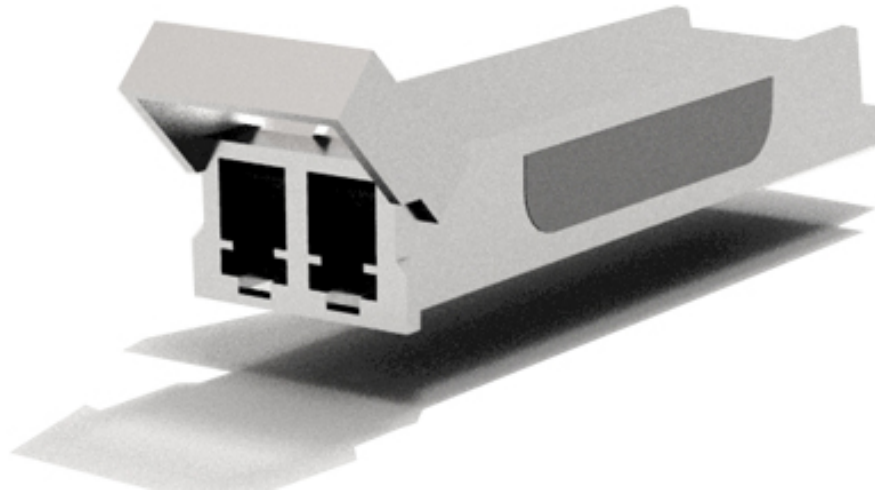

### Install a Bale Clasp SFP or SFP+ Module

To install this type of SFP or SFP+ module, follow these steps:

1. Attach an ESD-preventive wrist or ankle strap and follow its instructions for use.
2. Close the bale clasp before inserting the SFP module.
3. Line up the SFP module with the port and slide it into the port. (See the figure below.)

Figure 32: Installing a Bale Clasp SFP Module into a Port

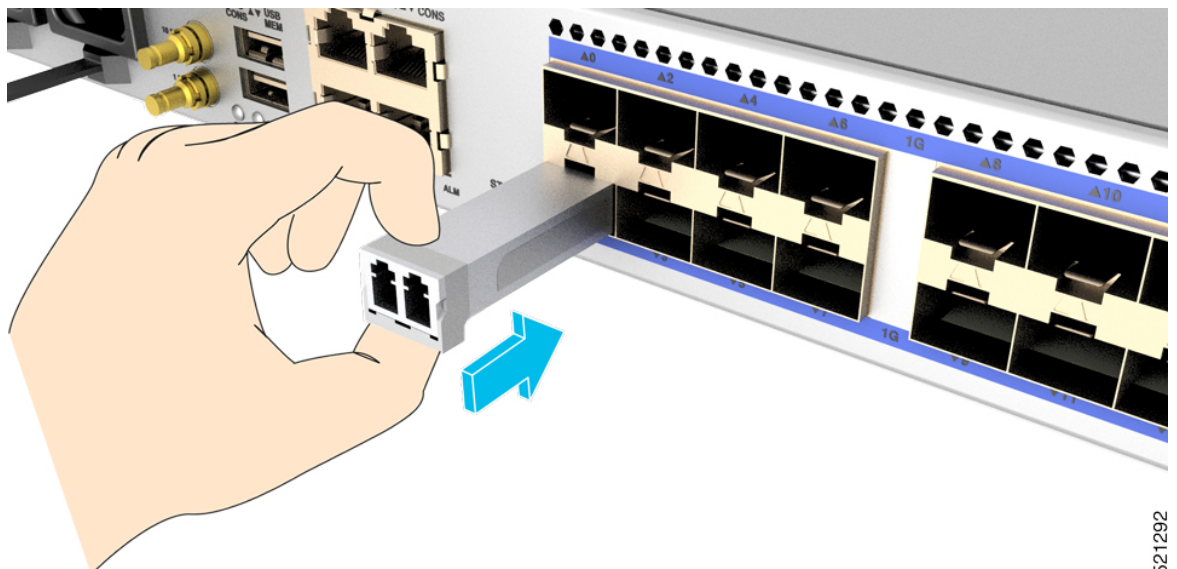



---

**Note** When installing an SFP or SFP+ module, you should hear a click as the triangular pin on the bottom of the SFP module snaps into the hole in the receptacle. This click indicates that the module is correctly seated and secured in the receptacle. Verify that the SFP modules are completely seated and secured in their assigned receptacles on the line card by firmly pushing on each SFP module.

---

### Remove a Bale Clasp SFP or SFP+ Module

To remove this type of SFP or SFP+ module, follow these steps:

1. Attach an ESD-preventive wrist or ankle strap and follow its instructions for use.
2. Disconnect and remove all interface cables from the ports; note the current connections of the cables to the ports on the router.
3. Open the bale clasp on the SFP module with your index finger, as shown in the figure below. If the bale clasp is obstructed and if you cannot open it using your index finger, use a small flat-blade screwdriver or other long, narrow instrument to open the bale clasp.
4. Grasp the SFP module between your thumb and index finger and carefully remove it from the port, as shown in the figure below.



---

**Note** This action must be performed during your first instance. After all ports are populated, this may not be possible.

---

Figure 33: Removing a Bale Clasp SFP or SFP+ Module

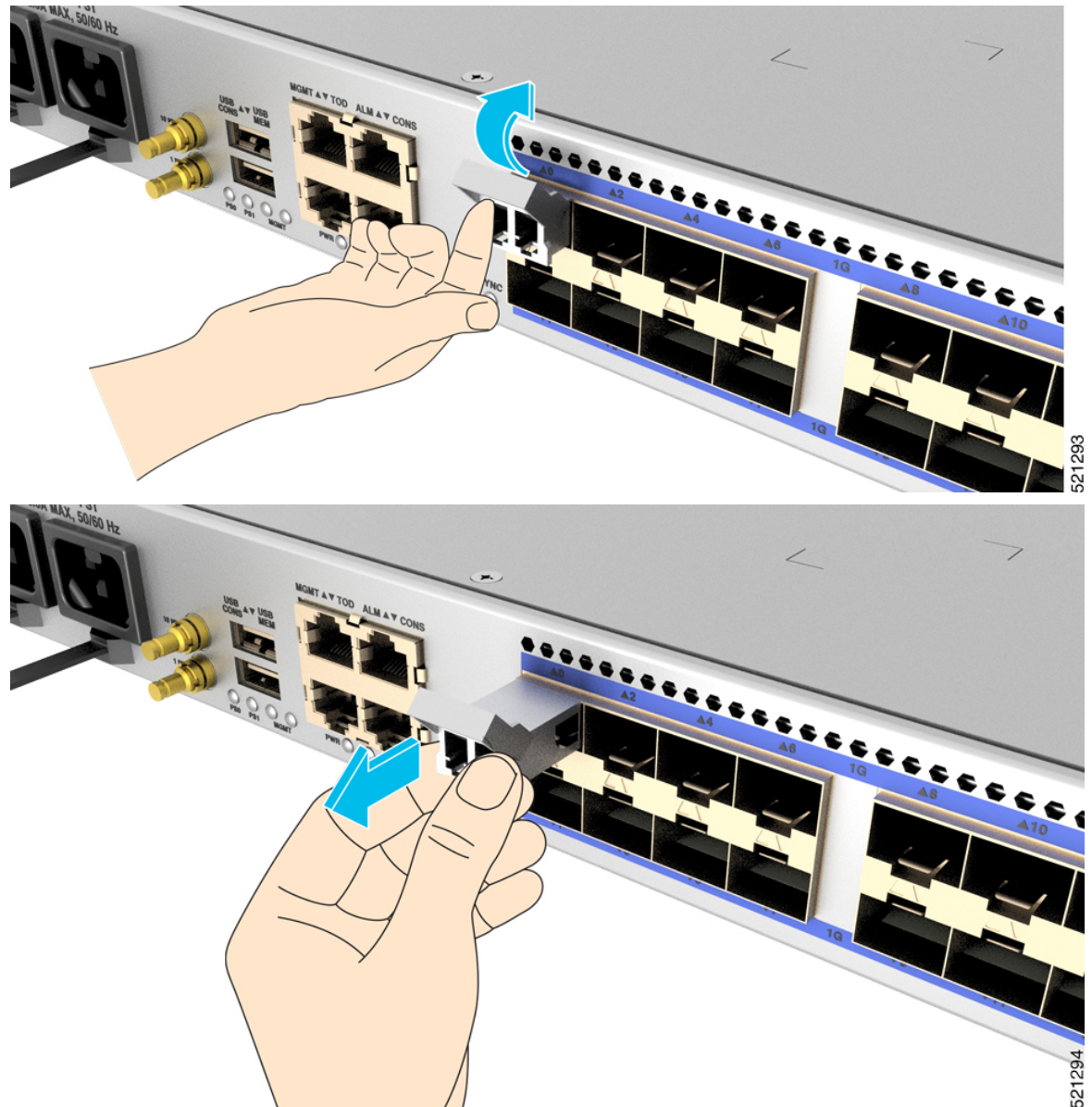

5. Place the SFP module that you removed on an antistatic mat, or immediately place it in a static shielding bag if you plan to return it to the factory.
6. Protect your router by inserting a clean SFP module cage covers into the optical module cage when there is no SFP module installed.

## Connect Interface Ports

You can connect optical interface ports on line cards with other devices for network connectivity.

## Connect a Fiber-Optic Port to the Network

Some transceivers work with fiber-optic cables that you attach to the transceivers and other transceivers work with pre-attached copper cables. When installing fiber-optic cables for a port, you must install SFP transceivers for 1-Gigabit optical ports or install SFP+ transceivers for 10-Gigabit optical ports before installing the fiber-optic cable in the transceivers.

**Caution**

Removing and installing a transceiver can shorten its useful life. Do not remove and insert transceivers more than it is absolutely necessary. We recommended that you disconnect cables before installing or removing transceivers to prevent damage to the cable or transceiver.

## Disconnect Optical Ports from the Network

When you need to remove fiber-optic transceivers, you must first remove the fiber-optic cables from the transceiver before you remove the transceiver from the port.

## Maintain Transceivers and Optical Cables

To maintain high signal accuracy and to prevent damage to the connectors, transceivers and fiber-optic cables must be kept clean and free of dust. Attenuation (loss of light) is increased by contamination and should be below 0.35 dB.

Consider the following maintenance guidelines:

- Transceivers are static sensitive. To prevent ESD damage, wear an ESD-preventative wrist strap that is connected to the grounded chassis.
- Do not remove and insert a transceiver more than it is necessary. Repeated removals and insertions can shorten its useful life.
- Keep all optical connections covered when not in use. Clean them before use to prevent dust from scratching the fiber-optic cable ends.
- Do not touch the ends of connectors. Touching the ends would leave fingerprints and cause other contamination.
- Clean the connectors regularly; the required frequency of cleaning depends upon the environment. In addition, clean connectors if they are exposed to dust or have been accidentally touched. Both wet and dry cleaning techniques can be effective; refer to your site's fiber-optic connection cleaning procedures.
- Inspect routinely for dust and damage. Clean and then inspect fiber ends under a microscope to determine whether any damage has occurred.

