



LEDs

- [Chassis LEDs, on page 1](#)
- [System Controller LEDs, on page 2](#)
- [Route Processor Card LEDs, on page 4](#)
- [Fan Tray LEDs, on page 6](#)
- [Fabric Card LEDs, on page 7](#)
- [Line Card LEDs, on page 8](#)
- [MPA LEDs, on page 9](#)
- [Power Supply LEDs, on page 10](#)
- [Port Status LEDs, on page 12](#)

Chassis LEDs

NCS 5504: Chassis LEDs are located at the bottom of the front of the chassis.

NCS 5508 and NCS 5516: Chassis LEDs are located at the top of the front of the chassis.

The LEDs indicate whether each type of module (route processor, controllers, line cards, fabric cards, fan trays, and power supplies) are fully functional or have a fault condition.

Table 1: Modular Chassis LED Descriptions

LED	Color	Status
ATTN	Flashing blue	The operator has activated this LED to identify this chassis.
	Off	This chassis is not being identified.
RP	Green	Route processor cards are all operational.
	Amber	Check the Route Processor Card LEDs for more information.
FC	Green	Fabric cards are all operational.
	Amber	Check the FAB LED description in the Fabric Card LEDs for more information.
	Off	No fabric cards are present, or all present fabric cards are in the shutdown configuration state.

LED	Color	Status
LC	Green	Line cards are all operational.
	Amber	Check the Line Card LEDs for more information.
	Off	No line cards are present, or all present line cards are in the shutdown configuration state.
PM	Green	Power supplies are all operational.
	Amber	Check the Power Supply LEDs for more information.
FT	Green	Fan trays are all operational.
	Amber	Check the Fan Tray LEDs for more information.
PWR MGMT	Green	Sufficient power is available for all of the installed modules.
	Amber	Either of the following conditions: <ul style="list-style-type: none"> • Insufficient power for at least one of the installed modules. • The configured power redundancy mode differs from the operational power redundancy.

System Controller LEDs

The system controller module LEDs are located on the left side of the module.

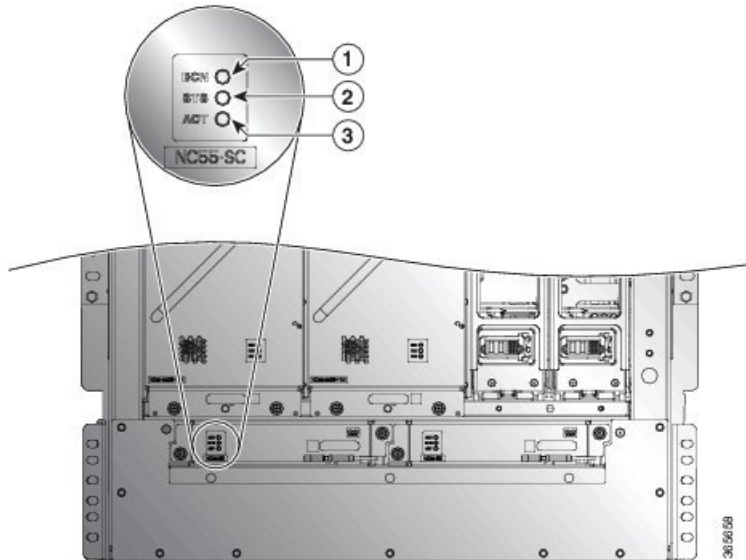
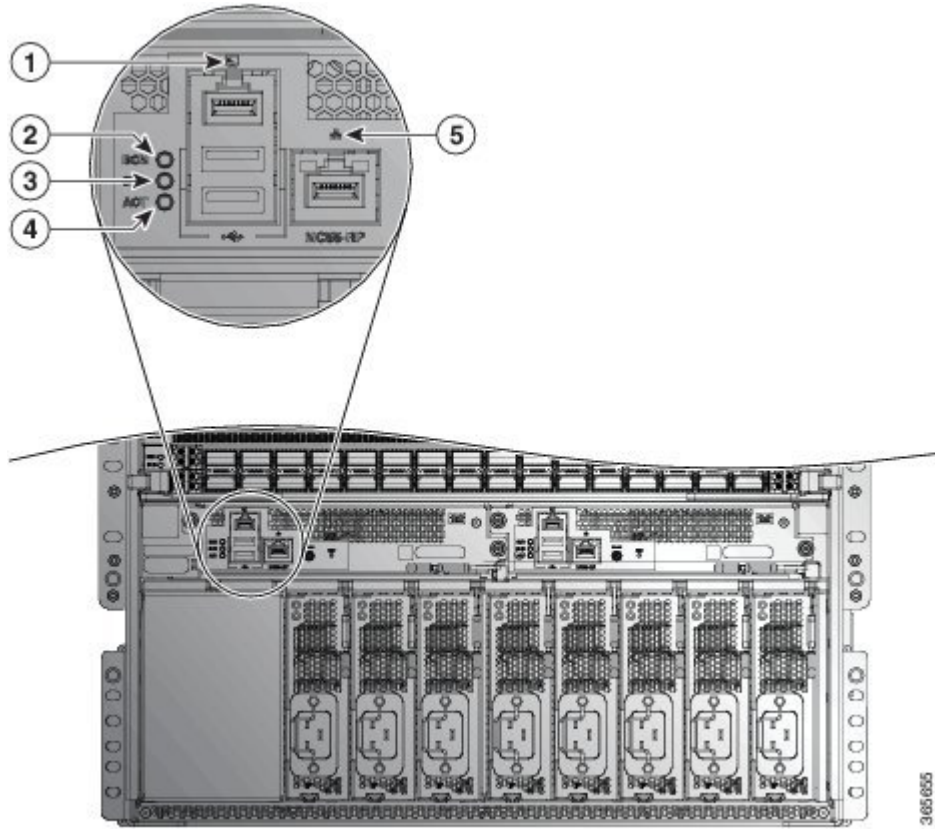

Table 2: System Controller LED Descriptions

LED	Color	Status
ATTN	Flashing blue	The operator has activated this LED to identify this module in the chassis.
	Off	This module is not being identified.
STS	Green	This module is operational.
	Amber	The host kernel has booted and is ready to start System Administrator VM.
	Red	Either of the following conditions: <ul style="list-style-type: none"> • The module has detected a slot ID parity error and will not power on or boot up. • The module is not fully inserted.
	Off	The module is not receiving power.
	Flashing Amber	The module is booting up or shutting down.
	Flashing Red	The module has active major or critical alarms.
ACT	Green	The controller module is operational and in active mode. This mode is established after the SysAdmin VM is booted up.
	Amber	The controller module is operational and in standby mode.
	Off	The hardware control is not established.

Route Processor Card LEDs



1	Attention (ATTN) LED	3	ACT (Active) LED
2	STS (Status) LED	4	Management port link and active LEDs

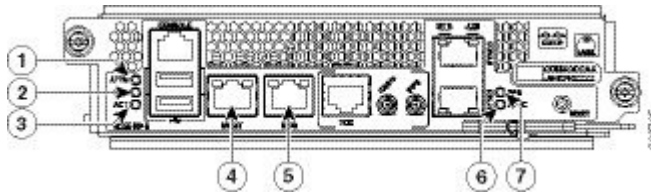

1	ATTN (Attention) LED	5	1588 port link and active LEDs
2	STS (Status) LED	6	SYNC LED
3	ACT (Active) LED	7	SYNC LED
4	Management port link and active LEDs		

Table 3: Route Processor Card LED Descriptions

LED	Color	Status
ATTN (Attention)	Flashing blue	The operator has activated this LED to identify this module in the chassis.
	Off	This module is not being identified.
STS (Status)	Green	This module is operational.
	Flashing amber	The module is booting up or shutting down.
	Flashing red	The module has active major or critical alarms.
	Amber	Host kernel booted and is ready to start System Administrator VM.
	Red	Either of the following conditions: <ul style="list-style-type: none"> • The module has detected a slot ID parity error and will not power on or boot up. • The module is not fully inserted.
	Off	The module is not receiving power.
ACT (Active)	Green	XR VM is operational and is in the active redundancy role on this module.
	Amber	XR VM is operational and is in the standby redundancy role on this module.
	Off	XR VM is not operational on this module.
Management port LINK	Green	The management port is linked up.
	Off	The management port is not linked up.
Management port ACT	Flashing green	The management port is transmitting or receiving.
	Off	The management port is not transmitting or receiving.
1588 port LINK (NC55-RP-E only)	Green	The 1588 port is linked up.
	Off	The 1588 port is not linked up.
1588 port ACT (NC55-RP-E only)	Flashing green	The 1588 port is transmitting or receiving.
	Off	The 1588 port is not transmitting or receiving.

LED	Color	Status
SYNC (NC55-RP-E only)	Green	The frequency, time, and phase are synchronized with an external interface (BITS, GPS, Recovered RX Clock).
	Amber	The time core is in free-run or holdover mode.
	Off	The time core clock synchronization is disabled. This is the default state after a reset.
GPS (NC55-RP-E only)	Green	The GPS interface is provisioned and ports are turned on. Time of day (ToD), 1 packet per second (1PPS), and 10MHz are all valid.
	Off	Either the interface is not provisioned or the ports are not turned on. ToD, 1PPS, and 10MHz are not valid.

Fan Tray LEDs

The fan tray LEDs are located on the lower right portion of the module.

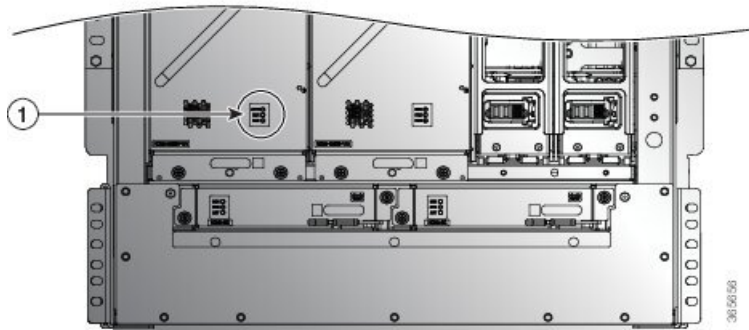

		LED	Color	Status
1	LED location	ATTN or BCN	Flashing Blue	The operator has activated this LED to identify this module in the chassis.
			Off	This module is not being identified.
		FAN	Green	The fan tray is operational.
			Flashing Red	One or more fans in this fan tray has failed.
			Off	No power is going to the fan tray.
		FAB	Green	Both fabric cards behind this fan tray are operational.
			Amber	At least one fabric card behind this fan tray is not operating.
			Off	No power is going to the fabric card behind this fan tray.

Fabric Card LEDs

The NCS 5504, NCS 5508 and NCS 5516 fabric cards are located behind the fan trays.

Table 4: Fabric Card LED Descriptions

LED	Color	Status
ATTN (top LED)	Flashing blue	The operator has activated this LED to identify this module in the chassis.
	Off	This module is not being identified.
STS (bottom LED)	Green	The fabric card is operational.
	Amber	Host kernel booted and is ready to start System Administrator VM.
	Red	Either of the following conditions: <ul style="list-style-type: none"> • The module has detected a slot ID parity error and will not power on or boot up. • The module is not fully inserted.
	Flashing red	The fabric card has major or critical alarms.
	Flashing amber (Slow)	The fabric card is booting up or shutting down.
	Flashing amber (Fast)	The module is booting up (set by U-Boot), shutting down, or the SysAdmin VM is being reloaded.
	Off	No power is going to the fabric card.

LED	Color	Status
Pushbutton (Graceful Shutdown)	Green	Software is ready to handle the graceful shutdown using the push button.
	Flashing yellow	Graceful shutdown in progress.
	Off	Graceful shutdown is complete; the module can be safely removed.

Line Card LEDs

The Attention (ATTN) and Status (STS) LEDs are located on the front left of the module, and the Link LED for each port is located between the two rows of ports (each of these LEDs is a triangle pointing to the port above or below the LED).

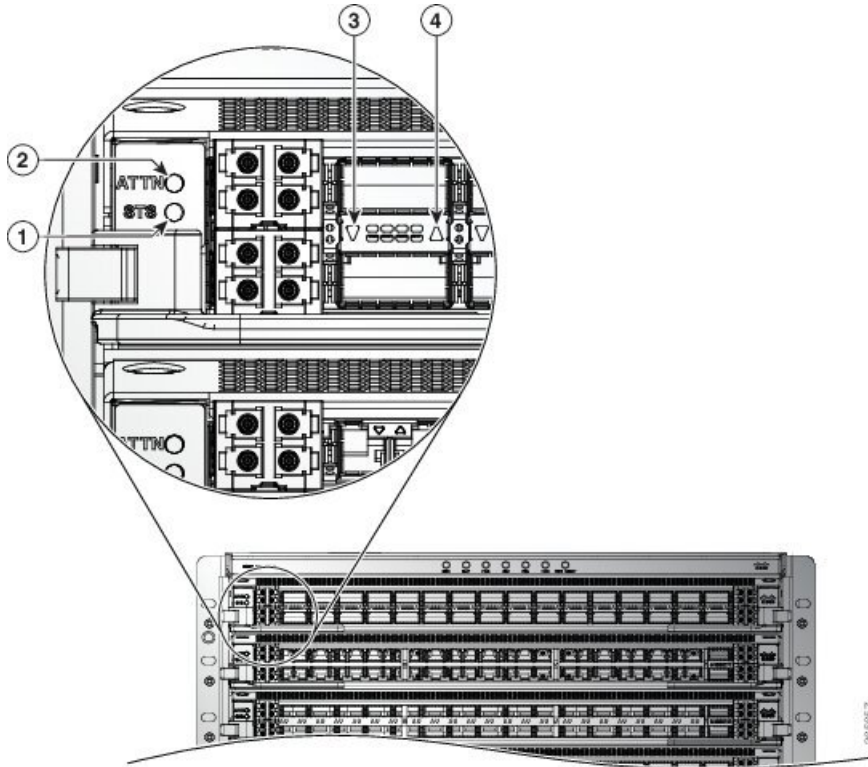

Table 5: Line Card LED Descriptions

LED	Color	Status
ATTN	Flashing blue	The operator has activated this LED to identify this module in the chassis.
	Off	This LED is not being used.

LED	Color	Status
STS	Green	This module is operational.
	Amber	Host kernel booted and is ready to start the system administrator VM.
	Red	Either of the following conditions: <ul style="list-style-type: none"> The card has detected a slot ID parity error and will not power on or boot up. The card is not fully inserted.
	Flashing red	The card has active major or critical alarms.
	Flashing amber	The card is booting up or shutting down.
	Off	The card is powered-off and can now be safely removed.
	Link (for each port)	Green
Orange		The port is disabled by the operator or is not initializing.
Flashing orange		The port is faulty and disabled.
Off		The port is not active or the link is not connected.

MPA LEDs

The STATUS LED is located on the front left of the MPA, the attention (ATTN) is located on the front right of the MPA, and the Link LED for each port is located between the two rows of ports (each of these LEDs is a triangle pointing to the port above or below the LED).

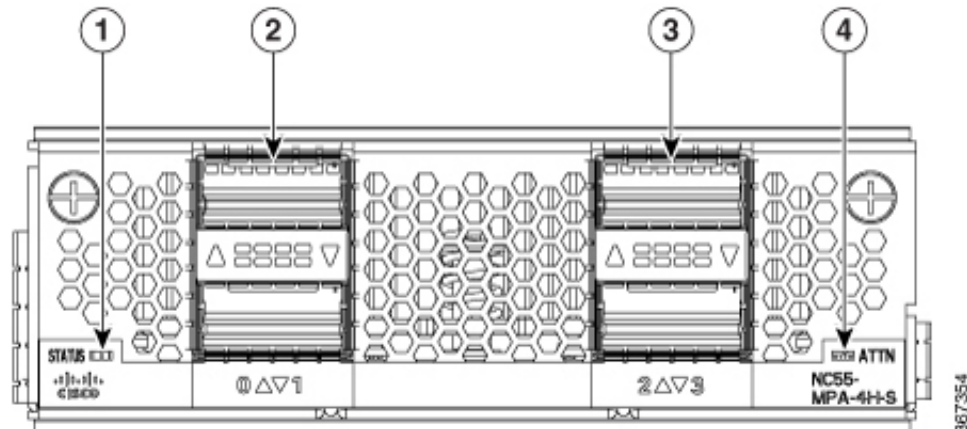

LED	Color	Status
ATTN	Flashing blue	The operator has activated this LED to identify this MPA in the chassis.
	Off	This LED is not being used.
STATUS	Green	This MPA is operational.
	Amber	Either of the following conditions: <ul style="list-style-type: none"> • The MPA has detected a slot ID parity error and will not power on or boot up. • The MPA is not fully inserted.
	Flashing amber	The MPA is booting up or shutting down.
	Off	The MPA is powered-off and can now be safely removed.
Link (for each port)	Green	The port is active.
	Orange	The port is disabled by the operator or is not initializing.
	Flashing orange	The port is faulty and disabled.
	Off	The port is not active or the link is not connected.

Power Supply LEDs

The power supply LEDs are located on the upper left front portion of the module.

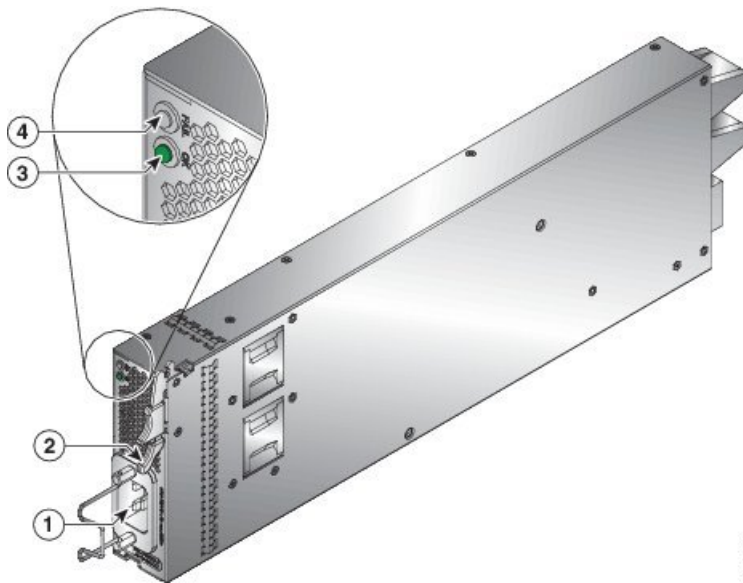

3085003

Table 6: Power Supply LED Descriptions

OK LED	FAIL or FAIL/ID LED	Status
Green	Off	Power supply is on and outputting power to the router.
Flashing green	Off	Power supply is connected to input power source but not outputting power to the router. The power supply might not be properly installed in the chassis.
Off	Off	Either all of the installed power supplies are not receiving power or an uninstalled power supply is not receiving power.
Off	Flashing amber - The amber LED blinks continuously at 1 second intervals.	Power supply is operating but a warning condition has occurred—possibly one of the following conditions: <ul style="list-style-type: none"> • High temperature • High power • Slow power supply fan • Low voltage • Power supply is installed without a connection to a power source.
Off	Amber	Power supply failure—possibly one of the following conditions: <ul style="list-style-type: none"> • Over voltage • Over current • Over temperature • Power supply fan failure

Table 7: HVAC/HVDC Power Supply LED Descriptions

IN LED	OUT LED	FAIL/ID LED	Status
Green	Green	Off	Both inputs are connected to power source. Power supply is on and outputting power to the router.
Flashing green	Green	Off	Power supply is connected to input power source but not outputting power to the router. The power supply might not be properly installed in the chassis.

IN LED	OUT LED	FAIL/ID LED	Status
Off	Off	Flashing amber - The amber LED blinks continuously at 1 second intervals.	Power supply is operating but a warning condition has occurred—possibly one of the following conditions: <ul style="list-style-type: none"> • High temperature • High power • Slow power supply fan • Low voltage • Power supply is installed without a connection to a power source.
Off	Off	Amber	Power supply failure—possibly one of the following conditions: <ul style="list-style-type: none"> • Over voltage • Over current • Over temperature • Power supply fan failure
-	-	Flashing blue	Power supply ID is enabled.

Port Status LEDs

Each port has an LED. The following table describes port status LEDs.

Table 8: Port Status LEDs (one per port)

LED Color	Description
Off	Port is administratively shut down.
Green	Port is administratively enabled and the link is up.
Amber	Port is administratively enabled and the link is down.
Single Amber Flash	Card reload is occurring. The LED blinks off-amber-off.