



Hardware Installation Guide for Cisco 8600 Series Routers

First Published: 2023-09-04

Americas Headquarters

Cisco Systems, Inc.
170 West Tasman Drive
San Jose, CA 95134-1706
USA
<http://www.cisco.com>
Tel: 408 526-4000
800 553-NETS (6387)
Fax: 408 527-0883

THE SPECIFICATIONS AND INFORMATION REGARDING THE PRODUCTS IN THIS MANUAL ARE SUBJECT TO CHANGE WITHOUT NOTICE. ALL STATEMENTS, INFORMATION, AND RECOMMENDATIONS IN THIS MANUAL ARE BELIEVED TO BE ACCURATE BUT ARE PRESENTED WITHOUT WARRANTY OF ANY KIND, EXPRESS OR IMPLIED. USERS MUST TAKE FULL RESPONSIBILITY FOR THEIR APPLICATION OF ANY PRODUCTS.

THE SOFTWARE LICENSE AND LIMITED WARRANTY FOR THE ACCOMPANYING PRODUCT ARE SET FORTH IN THE INFORMATION PACKET THAT SHIPPED WITH THE PRODUCT AND ARE INCORPORATED HEREIN BY THIS REFERENCE. IF YOU ARE UNABLE TO LOCATE THE SOFTWARE LICENSE OR LIMITED WARRANTY, CONTACT YOUR CISCO REPRESENTATIVE FOR A COPY.

The Cisco implementation of TCP header compression is an adaptation of a program developed by the University of California, Berkeley (UCB) as part of UCB's public domain version of the UNIX operating system. All rights reserved. Copyright © 1981, Regents of the University of California.

NOTWITHSTANDING ANY OTHER WARRANTY HEREIN, ALL DOCUMENT FILES AND SOFTWARE OF THESE SUPPLIERS ARE PROVIDED "AS IS" WITH ALL FAULTS. CISCO AND THE ABOVE-NAMED SUPPLIERS DISCLAIM ALL WARRANTIES, EXPRESSED OR IMPLIED, INCLUDING, WITHOUT LIMITATION, THOSE OF MERCHANTABILITY, FITNESS FOR A PARTICULAR PURPOSE AND NON-INFRINGEMENT OR ARISING FROM A COURSE OF DEALING, USAGE, OR TRADE PRACTICE.

IN NO EVENT SHALL CISCO OR ITS SUPPLIERS BE LIABLE FOR ANY INDIRECT, SPECIAL, CONSEQUENTIAL, OR INCIDENTAL DAMAGES, INCLUDING, WITHOUT LIMITATION, LOST PROFITS OR LOSS OR DAMAGE TO DATA ARISING OUT OF THE USE OR INABILITY TO USE THIS MANUAL, EVEN IF CISCO OR ITS SUPPLIERS HAVE BEEN ADVISED OF THE POSSIBILITY OF SUCH DAMAGES.

Any Internet Protocol (IP) addresses and phone numbers used in this document are not intended to be actual addresses and phone numbers. Any examples, command display output, network topology diagrams, and other figures included in the document are shown for illustrative purposes only. Any use of actual IP addresses or phone numbers in illustrative content is unintentional and coincidental.

All printed copies and duplicate soft copies of this document are considered uncontrolled. See the current online version for the latest version.

Cisco has more than 200 offices worldwide. Addresses and phone numbers are listed on the Cisco website at www.cisco.com/go/offices.

Cisco and the Cisco logo are trademarks or registered trademarks of Cisco and/or its affiliates in the U.S. and other countries. To view a list of Cisco trademarks, go to this URL: <https://www.cisco.com/c/en/us/about/legal/trademarks.html>. Third-party trademarks mentioned are the property of their respective owners. The use of the word partner does not imply a partnership relationship between Cisco and any other company. (1721R)

© 2023 Cisco Systems, Inc. All rights reserved.



CONTENTS

CHAPTER 1

Cisco 8600 Series Routers Overview	1
Cisco 8600 Series Routers	1
Modular Port Adapters Overview	4
Route Processor Overview	9
Switch Card Overview	11
Fan Spinner Overview	11
Temperature and Physical Specifications	12
Weight and Power Consumption	12
Airflow Direction	12
Maximum Power Available to Router	12
Supported Optics	14

CHAPTER 2

Prepare for Installation	15
Standard Warning Statements	15
Safety Guidelines	18
Compliance and Safety Information	19
Laser Safety	19
Energy Hazard	19
Preventing Electrostatic Discharge Damage	20
Cautions and Regulatory Compliance Statements for NEBS	20
Installation Guidelines	21
Procure Tools and Equipment	21
Router Accessory Kits	22
Prepare Your Location	22
Prepare Yourself	23
Prepare Rack for Chassis Installation	24

Clearance Requirements 25

CHAPTER 3**Unpack and Install the Chassis 27**

Unpack the Chassis 27

Install Bottom-Support Rails 29

Transfer Chassis to a Mechanical Lifting Device 30

Mount Chassis Into the Rack 32

Locate and Ground the Chassis 36

Installing a Cable Management Bracket 38

Attach Door Kit to Chassis 39

Attach Front Door to Chassis 41

CHAPTER 4**Powering on the Router 45**

Power Supply Overview 46

Power Connection Guidelines for AC-Powered Systems 47

Power Supply Unit Input and Output Ranges 49

Connect AC Power to the Chassis 50

Power Cord Retainer Mechanism 55

Connect a DC Power Supply to the Chassis 59

Install a DC Power Supply Unit in the Chassis 60

Connecting the DC-Input Wires 63

Power Up a DC Power Supply Unit 66

Power Supply Power Cord Specifications 67

3.2KW Power Supply Unit AC Power Cords 67

4.3KW Power Supply Power Cord Specifications 69

CHAPTER 5**Connect Router to the Network 85**

Connecting a Console to the Router 85

Connect the Management Interface 86

Transceivers, Connectors, and Cables 87

Transceiver and Cable Specifications 87

RJ-45 Connectors 87

Install and Remove SFP or SFP+ Modules 88

Bale Clasp SFP or SFP+ Module 89

Installing the Transceiver Module	90
Remove a Bale Clasp SFP or SFP+ Module	92
Install and Remove QSFP Transceiver Modules	93
Required Tools and Equipment	94
Installing the Transceiver Module	95
Attach the Optical Network Cable	97
Removing the Transceiver Module	98
Connect Interface Ports	100
Disconnect Optical Ports from the Network	100
Maintain Transceivers and Optical Cables	100
Create the Initial Router Configuration	100
Verify Chassis Installation	102
<hr/>	
CHAPTER 6	Replace Chassis Components 115
Replace a Route Processor Card	115
Migrating from Single Route Processor System to Dual-Route Processor System	119
Replace Modular Port Adapters	120
Remove a Modular Port Adapter	120
Install a Modular Port Adapter	122
Replace a Switch Card	125
Remove a Switch Card	126
Install a Switch Card	128
Replace a Fan Spinner	129
Remove a Fan Spinner	129
Install a Fan Spinner	131
Replace a Fan Module	131
Replace Power Modules	134
Remove an AC Power Supply Unit	134
Remove a DC Power Supply Unit	137
Power Down a DC Power Supply Unit	138
Disconnect the DC-Input Wires	138
Remove a DC Power Supply Unit from the Chassis	140

CHAPTER 7	LEDs 143
------------------	-----------------

Chassis LED 143

Route Processor LEDs 143

MPA LEDs 147

Power Supply LED 149

Fan Tray LED 154

Switch Card LED 155

Fan Spinner LEDs 157



CHAPTER

1

Cisco 8600 Series Routers Overview

- [Cisco 8600 Series Routers, on page 1](#)
- [Modular Port Adapters Overview, on page 4](#)
- [Route Processor Overview, on page 9](#)
- [Switch Card Overview, on page 11](#)
- [Fan Spinner Overview, on page 11](#)
- [Temperature and Physical Specifications, on page 12](#)
- [Weight and Power Consumption, on page 12](#)
- [Airflow Direction, on page 12](#)
- [Maximum Power Available to Router, on page 12](#)
- [Supported Optics, on page 14](#)

Cisco 8600 Series Routers

Cisco 8608

The Cisco 8608 is a Q200-based, 7-RU router that provides 12.8Tbps of network bandwidth and supports centralized architecture. The centralized architecture combines the best aspects of distributed and fixed systems. Cisco 8608 has combined the redundancy and I/O diversity of distributed systems with the economics and simple elegance of fixed platforms. As a result, Cisco 8608 delivers redundancy at an optimized cost while enabling flexibility and expandability through generational continuity.

The front of the chassis has the following:

- Route Processors (RP) Cards- Two RP cards that contain the CPU complex for managing the system.
- Modular Port Adapters (MPAs) - Eight pluggable MPAs.

Figure 1: Cisco 8608 - Front View

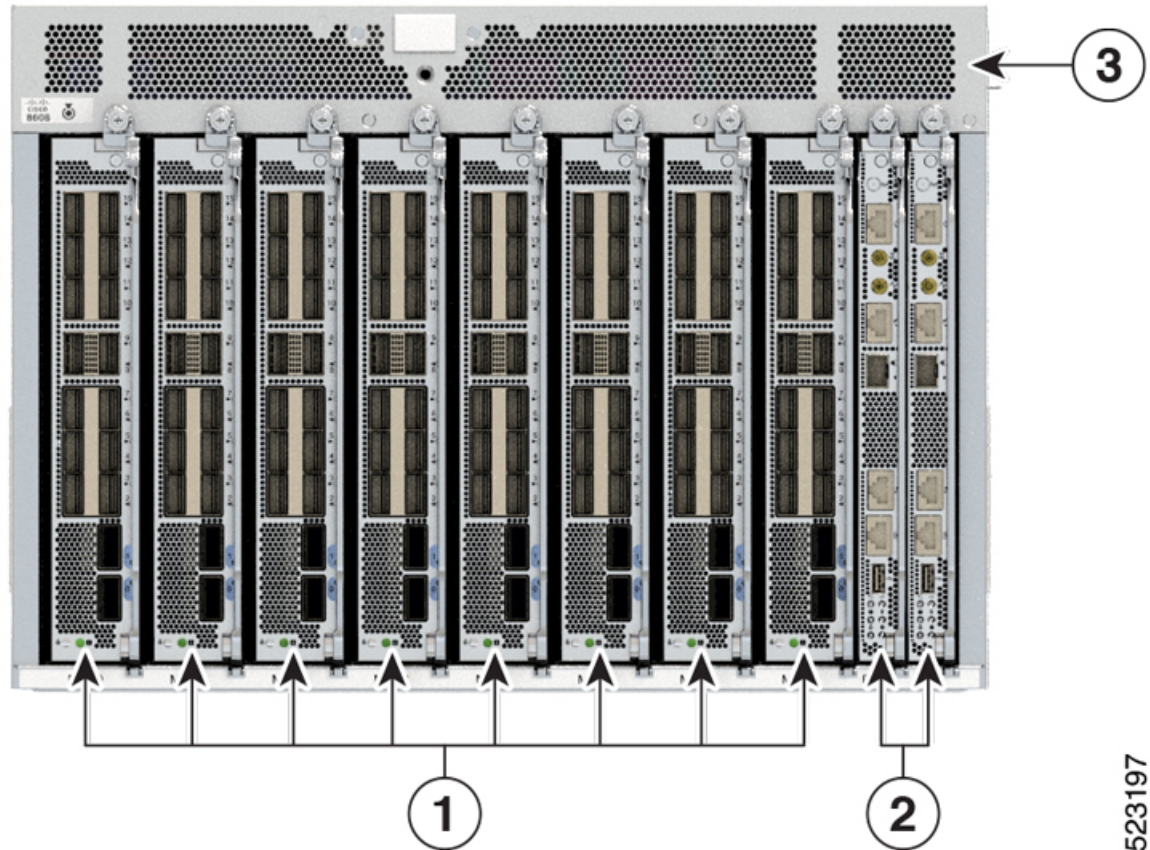

1	Modular Port Adapters (MPAs)
2	Route Processors (RPs)
3	Chassis

The rear of the chassis has the following:

- Switch Cards (SCs) - The two Switch Cards (SC0 and SC1) are horizontally mounted cards that include the forwarding engine using Q200 silicon.
- Power Modules - Four 3.2KW power modules operate at 220V capacity, providing N+N power redundancy. They also support operation at 110V with half of the capacity. The DC power modules are dual feed with 3.0 KW capacity. The power modules support port-side-intake (PSI) airflow direction and different AC/DC inputs capabilities.
- Fan Trays - Eight 80mm counter-rotating double-fan trays providing 7+1 redundancy. The 8 fan modules are installed in the SC and provide system cooling via a front to back cooling mechanism. The fan modules can be removed individually or altogether (with the SC card).

523197

Figure 2: Cisco 8608 - Rear View

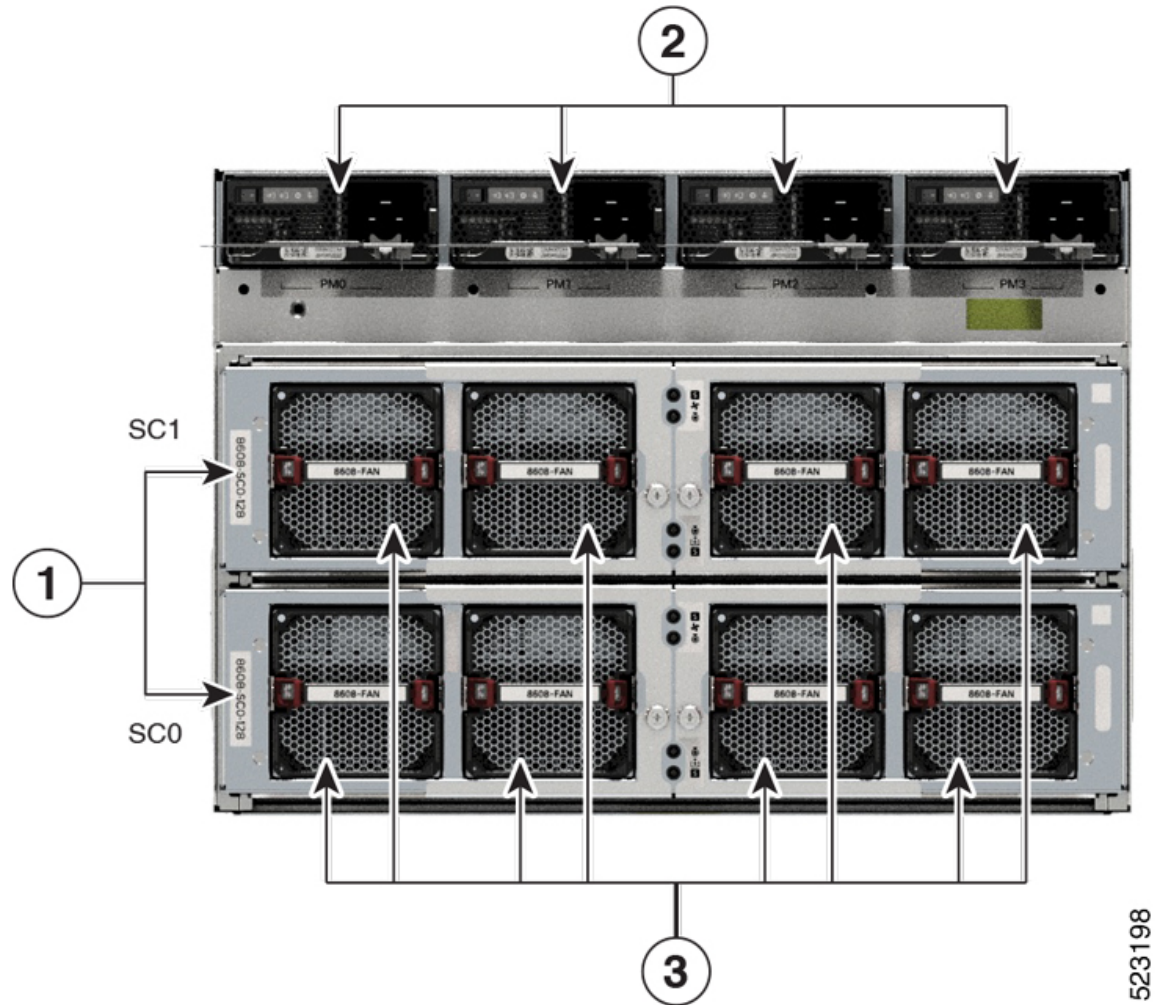

523198

1	Switch cards
2	Power modules
3	Fan modules

The following table describes the Cisco 8608 router components, and the supported quantity.

Table 1: Cisco 8608 Router Components

Component	Quantity
Modular Port Adapter (MPA)	8
Route Processor (RP)	2
Switch Card	2

Component	Quantity
Fan module	8
Power module	4 AC or 4 DC
Fan spinner	1 Note If you have one SC installed in the chassis, then the other SC slot is replaced by a fan spinner. The fan spinner is always installed inside the SC1 slot.

Modular Port Adapters Overview

Cisco 8600 Series Routers support the following Modular Port Adapters (MPAs):

Table 2: Supported MPAs on Cisco 8608 Router

MPA PIDs	Transceivers
86-MPA-14H2FH-M	QSFP-DD/QSFP
86-MPA-24Z-M	SFP
86-MPA-4FH-M	QSFP-DD

86-MPA-14H2FH-M

The following image explains the port details of the MPA:

Figure 3: 86-MPA-14H2FH-M Port Details

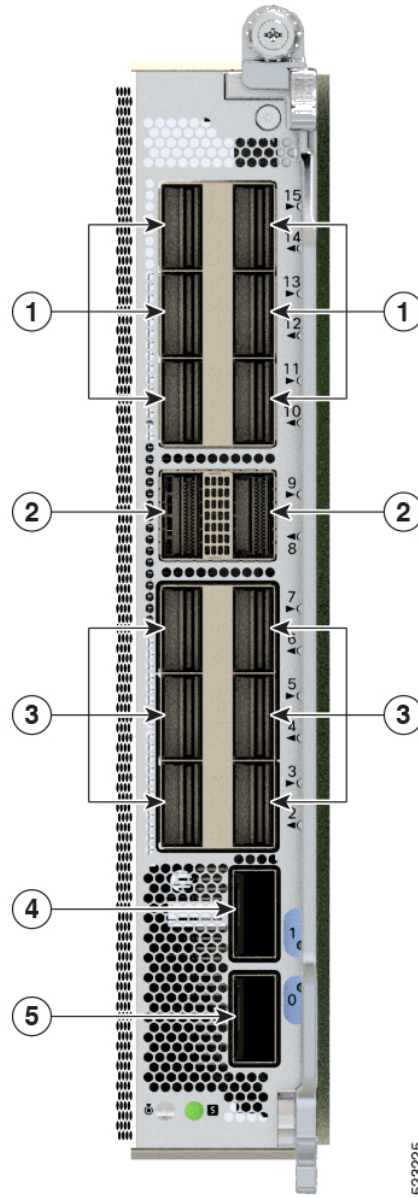

523225

1	QSFP (Ports 10, 11, 12, 13, 14, and 15)
2	QSFP (Ports 8 and 9)
3	QSFP (Ports 2, 3, 4, 5, 6, and 7)
4	QSFP-DD (Port 1)
5	QSFP-DD (Port 0)

The 86-MPA-14H2FH-M is a pluggable card that provides 16 interface ports that can support up to:

- 2 ports of QSFP-DD 400GbE modules and 14 ports of QSFP
- or
- 16 ports of QSFP 100GbE modules

When port 0 has a 400G QSFP-DD, then the other three ports (2, 3, 4) cannot be used. Similarly, when port 1 has a 400G QSFP-DD, then the other three ports (5, 6, 7) cannot be used.

86-MPA-24Z-M

The following image displays the MPA PID and explains the port configuration details of the MPA:

Figure 4: 86-MPA-24Z-M Handle

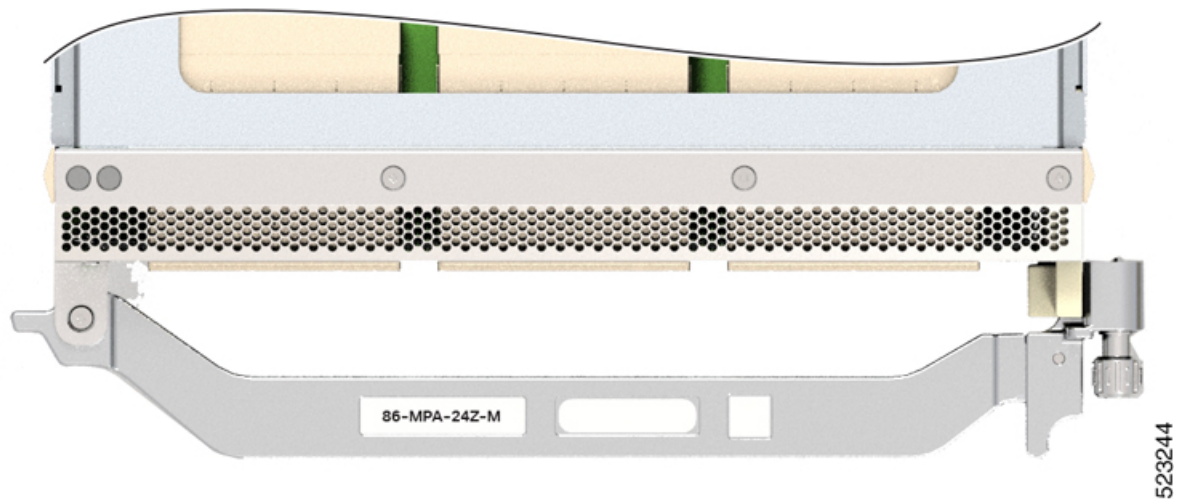
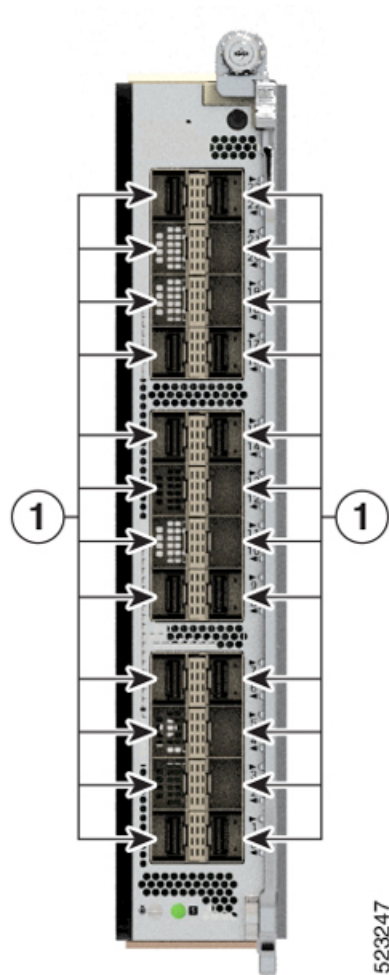

Figure 5: 86-MPA-24Z-M Port Details



1	SFP (Port 0 to 23)
Left row (even-numbered ports)	Ports 0, 2, 4, 6, 8, 10, 14, 16, 18, 20, 22
Right row (odd-numbered ports)	Ports 1, 3, 5, 7, 9, 11, 13, 15, 17, 19, 21, 23



Note You must set the N and N+1 ports on 86-MPA-24Z-M at a common speed, either at 10 GbE or 25 GbE. The router doesn't support mixed optics speed for paired N and N+1 ports. If you insert optics with different speeds in the N and N+1 ports, you must first set the ports at a common optics speed and then reload the MPA.

86-MPA-4FH-M

The following image displays the MPA PID and explains the port details of the MPA:

Figure 6: 86-MPA-4FH-M Handle

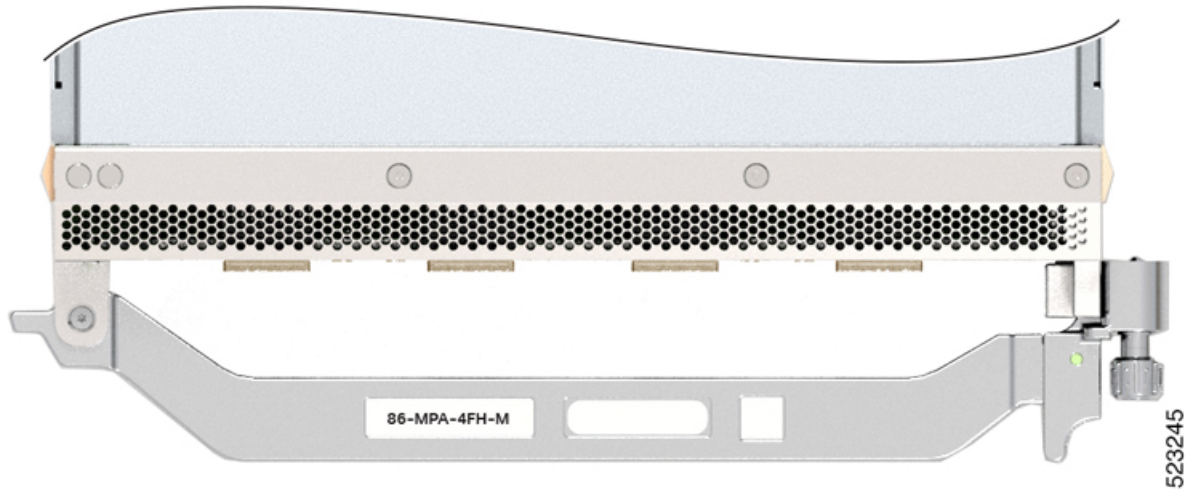
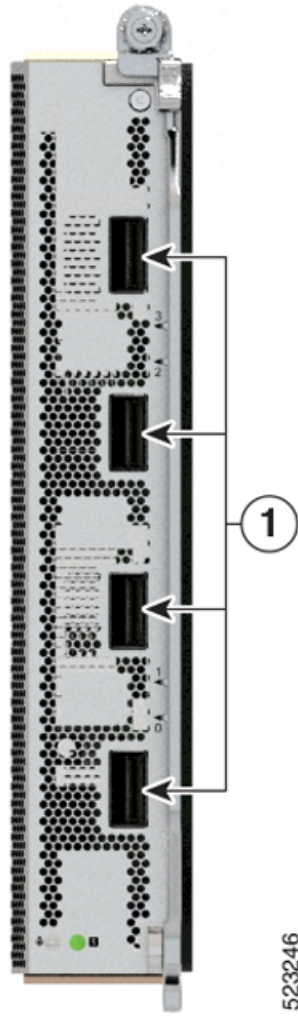

Figure 7: 86-MPA-4FH-M Port Details



1 Right row (even and odd-numbered ports)	QSFP-DD (Ports 0 to 3)
---	------------------------

Route Processor Overview

The Route Processors (RPs) (8608-RP) manages all routing operations on the Cisco 8600 Series Routers.

Figure 8: Route Processor - Front View

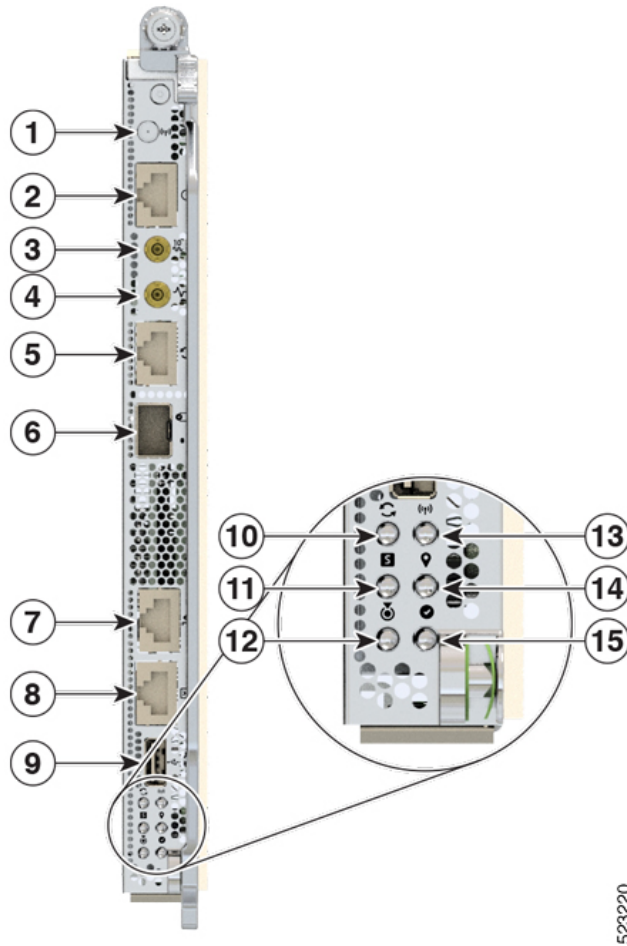

523220

1	GNSS Antenna	9	USB 3.0
2	Shielded RJ-45 connector for Time-of-Day (TOD) interface, input and output	10	Sync
3	Mini coaxial connector for 10 MHz, input and output	11	Status
4	Mini coaxial connector for 1 PPS, input and output	12	Attention
5	RJ-48 connector for BITS interface, input and output	13	GNSS
6	SFP+ SyncE 1588	14	GPS
7	Management Ethernet	15	Active
8	Console		



Caution The mini coaxial connectors for 10 MHz and 1 PPS have a knurled portion that you must hold to plug or unplug the connector cable. Pulling the cables can damage the connectors.

Switch Card Overview

The Cisco 8600 series routers are powered by the Cisco Silicon One Q200 series processors.

Cisco 8608 Q200 Silicon-based router comes with two Switch Cards (SCs) that provide 12.8Tbps of switching capacity and the SCs provide a bandwidth of 1.6Tbps to each of the eight MPAs.

Figure 9: Switch Card

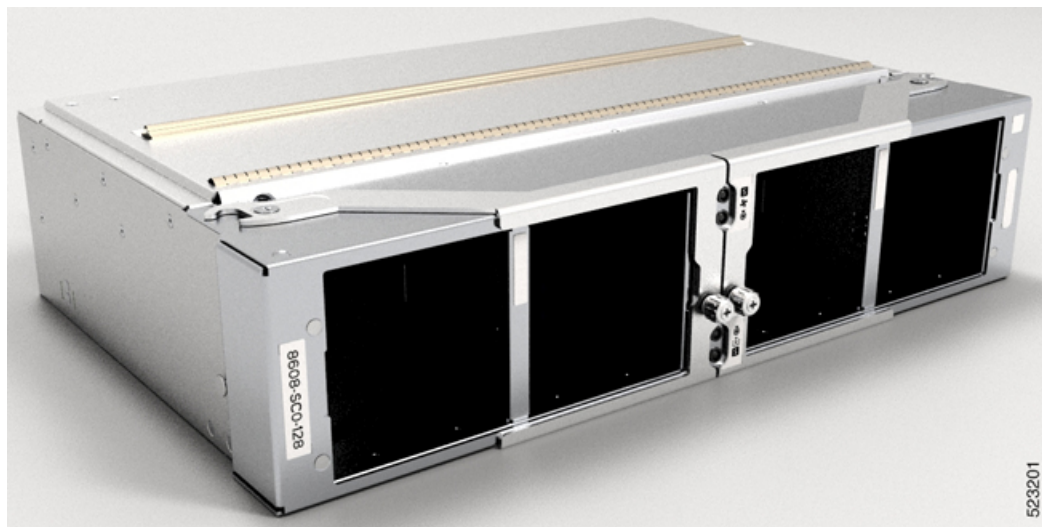

The SC is installed in the rear of the chassis. The eight fan trays are installed into the SC, each SC has four fan trays. If you need to remove or replace the SC, we recommend that you remove the fan trays.

Fan Spinner Overview

The Fan Spinner is installed in the rear of the chassis. The four fan trays are installed into the Fan Spinner. If you need to remove or replace the Fan Spinner, we recommend that you remove the fan trays.



Note A Fan Spinner is always installed into the SC1 slot.

Figure 10: Fan Spinner

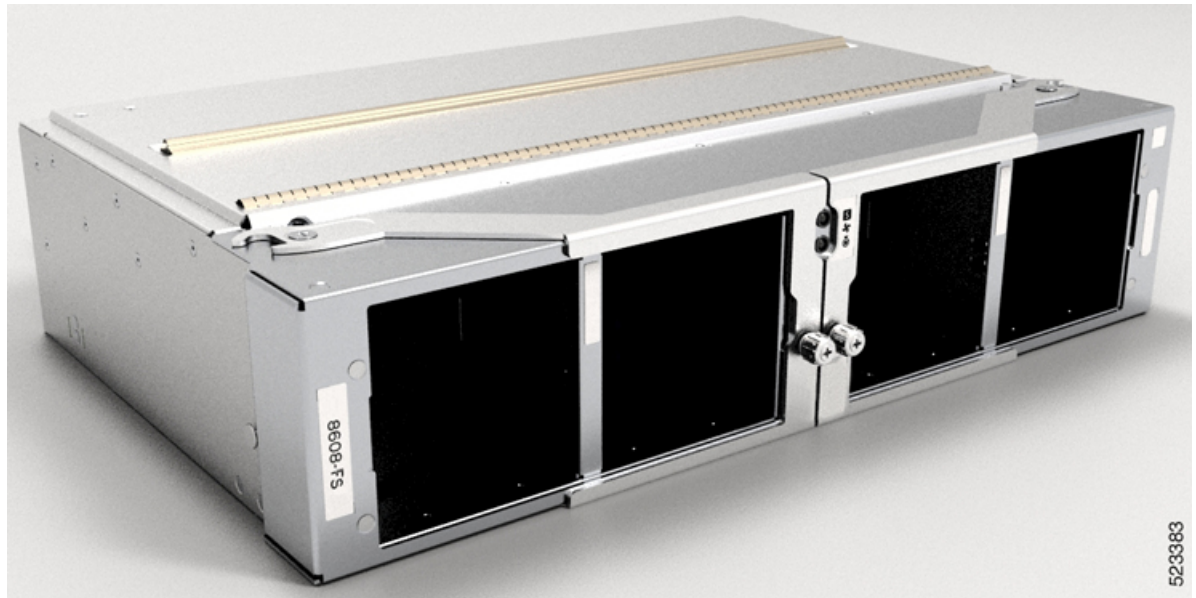

Temperature and Physical Specifications

For temperature and physical specifications, refer to the *Physical characteristics* table in the [Cisco 8608 Router Data Sheet](#).

Weight and Power Consumption

For weight and power consumption, refer to the *Physical characteristics* table in the [Cisco 8608 Router Data Sheet](#).

Airflow Direction

The airflow through the fan trays and power supplies on the Cisco 8600 series routers are from front to back (port side intake).

To ensure proper airflow for the router in your facility, position the router with its air intake on a cold aisle and the air exhaust on a hot aisle.

Maximum Power Available to Router

The maximum power available to the router depends on the following factors:

- the input power from your power source
- the number of Power Supply Units (PSUs)

- the type of PSU selected, either 3.2KW or 4.3KW PSU
- the output capabilities of the PSUs
- the power redundancy mode that you use

The following tables list the amount of power available for Cisco 8600 series routers from all available power trays.

Table 3: Maximum Power Available from 3.2KW PSUs

Number of PSUs	Combined Mode in Watts (No redundancy)	N+1 Redundancy Mode in Watts (with Single Supply Loss)
1	3190	—
2	6380	3190
3	9570	6380
4	12760	9570

Table 4: Maximum Power Available from 4.3KW PSUs

Number of PSUs	Single Input HVPI (AC/DC) Combined Mode in Watts (No redundancy)	Dual Input HVPI (AC/DC) Combined Mode in Watts (No redundancy)	N+1 Redundancy Mode in Watts (with Single Supply Loss) Single Input	N+1 Redundancy Mode in Watts (with Single Supply Loss) Dual Input
1	3190	4300	—	—
2	6380	8600	3190	4300
3	9570	12900	6380	8600
4	12760	17200	9570	12900

Supported Optics



Note To determine which transceivers and cables are supported by this router, refer to the Transceiver Module Group (TMG) Compatibility Matrix Tool:

<https://tmgmatrix.cisco.com/>

- For QSFP-DD data sheets, refer to the [Cisco 400G QSFP-DD Cable and Transceiver Modules Data Sheet](#).
 - For QSFP28 data sheets, refer to the [Cisco 100GBASE QSFP-100G Modules Data Sheet](#).
 - For QSFP+ data sheets, refer to the [Cisco 40GBASE QSFP Modules Data Sheet](#).
 - For SFP data sheets, refer to the [Cisco 50GBASE SFP56 Modules Data Sheet](#)
 - For SFP28 data sheets, refer to the [Cisco 25GBASE SFP28 Modules Data Sheet](#)
-



CHAPTER 2

Prepare for Installation

This chapter provides preinstallation information, such as recommendations and requirements that must be met before installing your router. Before you begin, inspect all items for shipping damage. If anything appears to be damaged or if you encounter problems installing or configuring your router, contact customer service.



Note The images in this chapter are only for representational purposes, unless specified otherwise. The chassis' actual appearance and size may vary.

- [Standard Warning Statements, on page 15](#)
- [Safety Guidelines, on page 18](#)
- [Compliance and Safety Information, on page 19](#)
- [Laser Safety, on page 19](#)
- [Energy Hazard, on page 19](#)
- [Preventing Electrostatic Discharge Damage, on page 20](#)
- [Cautions and Regulatory Compliance Statements for NEBS, on page 20](#)
- [Installation Guidelines, on page 21](#)
- [Procure Tools and Equipment, on page 21](#)
- [Prepare Your Location , on page 22](#)
- [Prepare Yourself , on page 23](#)
- [Prepare Rack for Chassis Installation, on page 24](#)
- [Clearance Requirements, on page 25](#)

Standard Warning Statements

This section describes the warning definition and then lists core safety warnings grouped by topic.

**Warning Statement 1071—Warning Definition****IMPORTANT SAFETY INSTRUCTIONS**

Before you work on any equipment, be aware of the hazards involved with electrical circuitry and be familiar with standard practices for preventing accidents. Read the installation instructions before using, installing, or connecting the system to the power source. Use the statement number at the beginning of each warning statement to locate its translation in the translated safety warnings for this device.

SAVE THESE INSTRUCTIONS

**General Safety Warnings****Warning Statement 1089—Instructed and Skilled Person Definitions**

An instructed person is someone who has been instructed and trained by a skilled person and takes the necessary precautions when working with equipment.

A skilled person or qualified personnel is someone who has training or experience in the equipment technology and understands potential hazards when working with equipment.

There are no serviceable parts inside. To avoid risk of electric shock, do not open.

**Warning Statement 9001—Product Disposal**

Ultimate disposal of this product should be handled according to all national laws and regulations.

**Warning Statement 1073—No User-Serviceable Parts**

There are no serviceable parts inside. To avoid risk of electric shock, do not open.

**Warning Statement 1074—Comply with Local and National Electrical Codes**

To reduce risk of electric shock or fire, installation of the equipment must comply with local and national electrical codes.



Note **Statement 407**—Japanese Safety Instruction

You are strongly advised to read the safety instruction before using the product.

<https://www.cisco.com/web/JP/techdoc/pldoc/pldoc.html>

When installing the product, use the provided or designated connection cables/power cables/AC adapters.

〈製品仕様における安全上の注意〉
www.cisco.com/web/JP/techdoc/index.html

接続ケーブル、電源コードセット、ACアダプタ、バッテリーなどの部品は、必ず添付品または指定品をご使用ください。添付品・指定品以外をご使用になると故障や動作不良、火災の原因となります。また、電源コードセットは弊社が指定する製品以外の電気機器には使用できないためご注意ください。



Warning **Statement 1090**—Installation by Skilled Person

Only a skilled person should be allowed to install, replace, or service this equipment. See statement 1089 for the definition of a skilled person.

There are no serviceable parts inside. To avoid risk of electric shock, do not open.



Warning **Statement 1091**—Installation by an Instructed Person

Only an instructed person or skilled person should be allowed to install, replace, or service this equipment. See statement 1089 for the definition of an instructed or skilled person.

There are no serviceable parts inside. To avoid risk of electric shock, do not open.



Warning **Statement 1029**—Blank Faceplates and Cover Panels

Blank faceplates and cover panels serve three important functions: they reduce the risk of electric shock and fire, they contain electromagnetic interference (EMI) that might disrupt other equipment, and they direct the flow of cooling air through the chassis. Do not operate the system unless all cards, faceplates, front covers, and rear covers are in place.

**Warning Statement 1015**—Battery Handling

To reduce risk of fire, explosion, or leakage of flammable liquid or gas:

- Replace the battery only with the same or equivalent type recommended by the manufacturer.
- Do not dismantle, crush, puncture, use a sharp tool to remove, short the external contacts, or dispose of the battery in fire.
- Do not use if battery is warped or swollen.
- Do not store or use battery in a temperature $>$.
- Do not store or use battery in low air pressure environment $<$.

Safety Guidelines

Before you perform any procedure in this document, review the safety guidelines in this section to avoid injuring yourself or damaging the equipment. The following guidelines are for your safety and to protect the equipment. Because the guidelines do not include all hazards, be constantly alert.

- Keep the work area clear, smoke and dust-free during and after installation. Do not allow dirt or debris to enter into any laser-based components.
- Do not wear loose clothing, jewelry, or other items that could get caught in the router or other associated components.
- Cisco equipment operates safely when used in accordance with its specifications and product-usage instructions.
- If potentially hazardous conditions exist, do not work alone.
- Take care when connecting multiple units to the supply circuit so that wiring is not overloaded.
- This equipment must be grounded. Never defeat the ground conductor or operate the equipment in the absence of a suitably installed ground conductor. Contact the appropriate electrical inspection authority or an electrician if you are uncertain about whether suitable grounding is available.
- When installing or replacing the unit, the ground connection must always be made first and disconnected last.
- To prevent personal injury or damage to the chassis, never attempt to lift or tilt the chassis using the handles on modules (such as power supplies, fans, or cards); these types of handles are not designed to support the weight of the unit.
- Hazardous voltage or energy is present on the backplane when the system is operating. Use caution when servicing.

Compliance and Safety Information

The Cisco 8000 Series Routers are designed to meet the regulatory compliance and safety approval requirements. For detailed safety information, see [Regulatory Compliance and Safety Information—Cisco 8000 Series Routers](#).

Laser Safety



Warning **Statement 1051**—Laser Radiation

Invisible laser radiation may be emitted from disconnected fibers or connectors. Do not stare into beams or view directly with optical instruments.



Warning **Statement 1055**—Class 1/1M Laser

Invisible laser radiation is present. Do not expose to users of telescopic optics. This applies to Class 1/1M laser products.



Warning **Statement 1255**—Laser Compliance Statement

Pluggable optical modules comply with IEC 60825-1 Ed. 3 and 21 CFR 1040.10 and 1040.11 with or without exception for conformance with IEC 60825-1 Ed. 3 as described in Laser Notice No. 56, dated May 8, 2019.

Energy Hazard

The routers can be configured for a DC power source. Do not touch terminals while they are live. Observe the following warning to prevent injury.



Warning **Statement 1086**—Power Terminals

Hazardous voltage or energy may be present on power terminals. Always replace cover when terminals are not in service. Be sure uninsulated conductors are not accessible when cover is in place.

Preventing Electrostatic Discharge Damage

Many router components can be damaged by static electricity. Not exercising the proper electrostatic discharge (ESD) precautions can result in intermittent or complete component failures. To minimize the potential for ESD damage, always use an ESD-preventive antistatic wrist strap (or ankle strap) and ensure that it makes adequate skin contact.



Note Check the resistance value of the ESD-preventive strap periodically. The measurement should be 1–10 megohms.

Before you perform any of the procedures in this guide, attach an ESD-preventive strap to your wrist and connect the leash to the chassis.

Cautions and Regulatory Compliance Statements for NEBS

The NEBS-GR-1089-CORE regulatory compliance statements and requirements are discussed in this section.



Warning The intrabuilding port(s) of the equipment or subassembly, which is the management Ethernet port, must use shielded intrabuilding cabling/wiring that is grounded at both ends. Statement 7003



Warning The intrabuilding port(s) of the equipment or subassembly, which is the management Ethernet port, must not be metallically connected to interfaces that connect to the OSP or its wiring. These interfaces are designed for use as intrabuilding interfaces only (Type 2 or Type 4 ports as described in GR-1089-CORE) and require isolation from the exposed OSP cabling. The addition of Primary Protectors is not sufficient protection in order to connect these interfaces metallically to OSP wiring. Statement 7005



Warning This equipment shall be connected to AC mains provided with a surge protective device (SPD) at the service equipment complying with NFPA 70, the National Electrical Code (NEC). Statement 7012



Warning This equipment is suitable for installations utilizing the Common Bonding Network (CBN). Statement 7013



Warning The battery return conductor of this equipment shall be treated as (DC-I). Statement 7016



Warning This equipment is suitable for installation in Network Telecommunications Facilities. Statement 8015

**Warning**

This equipment is suitable for installation in locations where the NEC applies. Statement 8016

Installation Guidelines

Before installing the chassis, ensure that the following guidelines are met:

- Site is properly prepared so that there is sufficient room for installation and maintenance.
- Operating environment is within the ranges that are listed in Environment and Physical specifications. For more details on environmental requirements, see [Cisco 8608 Router Data Sheet](#).
- Chassis is mounted at the bottom of the rack if it is the only unit in the rack.
- When mounting the chassis in a partially filled rack, load the rack from the bottom to the top with the heaviest component at the bottom of the rack.
- If the rack is provided with stabilizing devices, install the stabilizers before mounting or servicing the chassis in the rack.
- Airflow around the chassis and through the vents is unrestricted.
- Cabling is away from sources of electrical noise, such as radios, power lines, and fluorescent lighting fixtures. Make sure that the cabling is safely away from other devices that might damage the cables.
- Each port must match the wave-length specifications on each end of the cable, and the cable must not exceed the stipulated cable length.

**Note**

Cisco 8000 Series Routers function in operating temperatures of up to 40°C at sea level. For every 300 meters (1000 ft) elevation upto 1800 meters (6000 ft), the maximum temperature is reduced by 1°C. For more details on environmental requirements, see [Cisco 8608 Router Data Sheet](#).

Procure Tools and Equipment

Obtain these necessary tools and equipment for installing the chassis:

- Number 1 and number 2 Phillips screwdrivers with torque capability to rack-mount the chassis.
- 3/16-inch flat-blade screwdriver.
- Tape measure and level.
- ESD wrist strap or other grounding device.
- Antistatic mat or antistatic foam.
- Two-hole ground lug (1).
- A crimping tool specified by the lug manufacturer that is large enough to accommodate the girth of the lug.

- Wire-stripping tool.

Router Accessory Kits

Router Accessory Kit

The accessory kits for the Cisco 8608 fixed port router includes the following:

Table 5: Router Accessory Kits

Kit Name	Description	Quantity
Ground lug kit	90 degree lug	1
	M4 x 6-mmPhillips flat-head screws	2
Rack mount kit (8608-RMBRKT)	Rack-mount brackets	8
	M4 x 6-mmPhillips flat-head screws	20
Door kit (8608-DRKT)	Door frame	2
	M4 x 6 mm pan-head Phillips screws	9



Note If you purchased this product through a Cisco reseller, you might receive more contents in your kit, such as documentation, hardware, and power cables.

The shipped cables depend on your specification when placing an order. See the *Power Supply Power Cord Specifications* section for information on the available power cords.

Discrepancies or Damage?

If you notice any discrepancies or damage, send the following information to your customer service representative by email:

- Invoice number of the shipper (see the packing slip)
- Model and serial number of the missing or damaged unit
- Description of the problem and how it affects the installation
- Photos of the damage to external packaging, internal packaging, and product

Prepare Your Location

This section illustrates how the building that houses the chassis must be properly grounded to the earth ground.



Note Unless specified otherwise, the image is only for representational purposes. The rack's actual appearance and size may vary.



Note This image is only for representational purposes. Your grounding requirement depends on your building.

Figure 11: Building with Rack Room Connected to Earth Ground

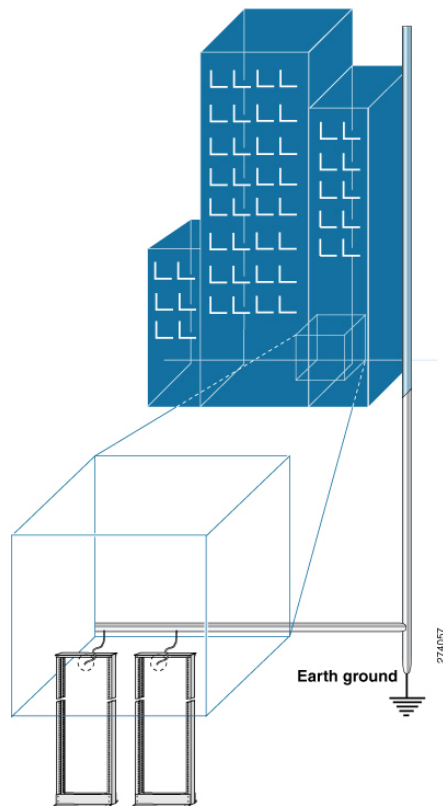

Prepare Yourself

This section illustrates how to prepare yourself before removing the chassis from the sealed antistatic bag. The figures show how to cuff the ESD strap around the wrist and the ground cord that connects the cuff to the ground. ESD wrist straps are the primary means of controlling static charge on personnel.

Figure 12: Wearing the ESD Strap

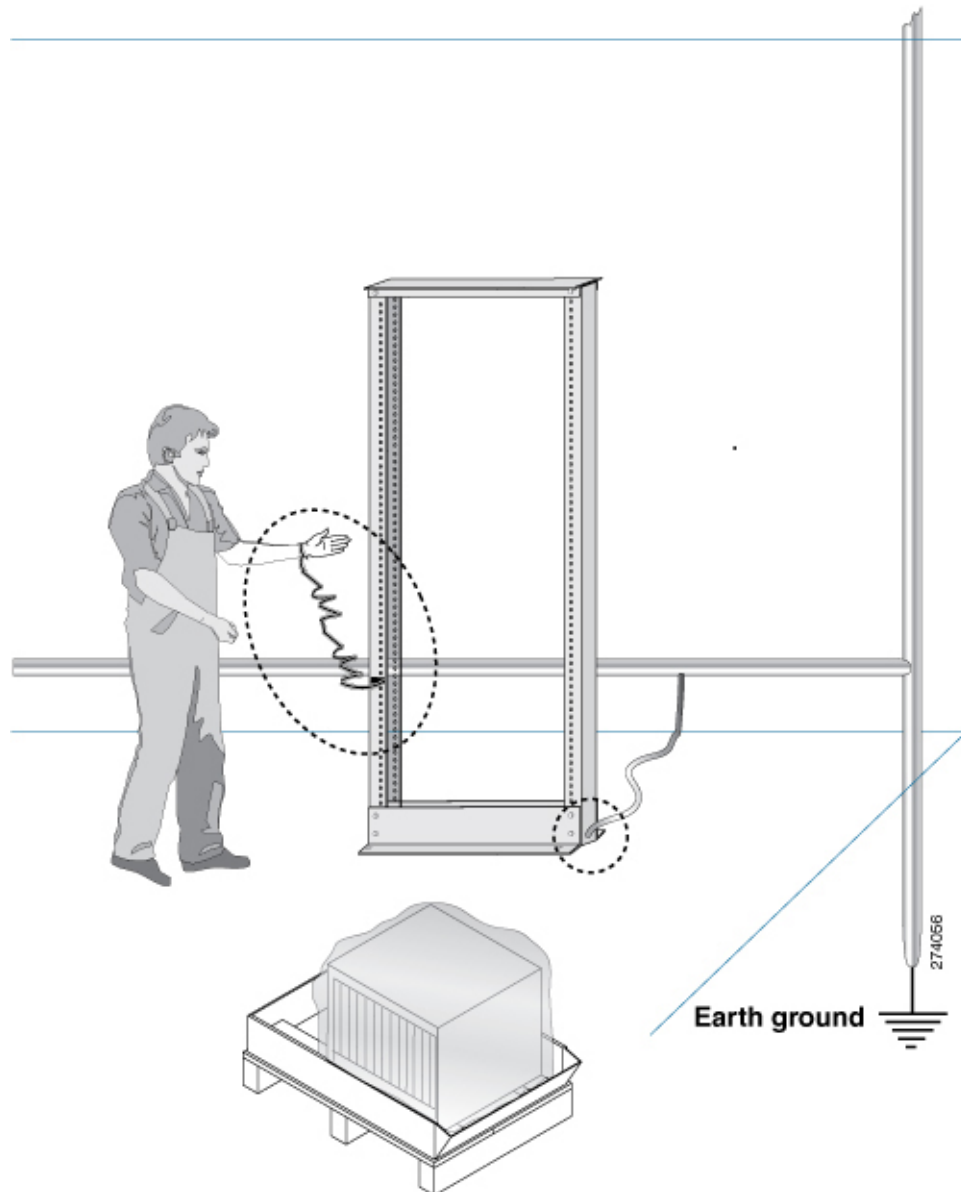

Prepare Rack for Chassis Installation

Install the Cisco 8600 Series Routers on a standard 19 inch, Electronic Industries Alliance (EIA) rack with mounting rails that conform to English universal hole spacing according to Section 1 of the ANSI/EIA-310-D-1992 standard.



Note The Cisco 8600 router rack mount kit contains the rack mounting brackets for 19-inch rack.

The spacing between the posts of the rack must be (EIA-310-D-1992 19-inch rack compatible) wide enough to accommodate the width of the chassis.

Figure 13: Rack Specification EIA (19 inches)

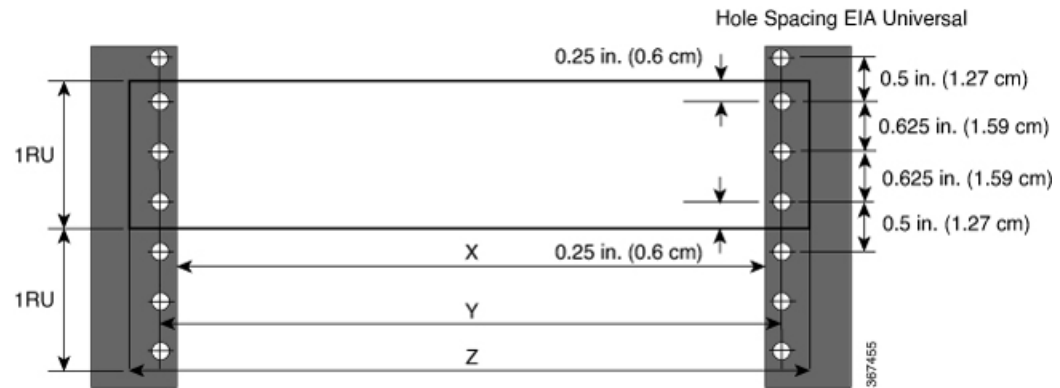

Table 6: Rack Specification EIA (19 inches)

Post Type	Rack Type	Rack Front Opening (X)	Rack Mounting Hole Center-Center (Y)	Mounting Flange Dimension (Z)
4 Post	19 inches (48.3 centimeters)	450.8mm (17.75")	465mm (18.312")	482.6mm (19")
4 Post	23 inches (58.4 centimeters)	552.45mm (21.75")	566.7mm (22.312")	584.2mm (23")

Before you move the chassis or mount the chassis into the rack, we recommend that you do the following:

Procedure

Step 1 Place the rack at the location where you plan to install the chassis.

Step 2 (Optional) Secure the rack to the floor.

To bolt the rack to the floor, a floor bolt kit (also called an anchor embedment kit) is required. For information on bolting the rack to the floor, consult a company that specializes in floor mounting kits (such as Hilti; see Hilti.com for details). Make sure that floor mounting bolts are accessible, especially if annual retorquing of bolts is required.

Note Ensure that the rack in which the chassis is being installed is grounded to earth ground.

Clearance Requirements

To ensure adequate airflow, we recommended that you maintain a minimum of 6 in. (15.24 cm) front and rear clearance for air intake/exhaust.

If the router is installed in a perforated door cabinet, maintain a minimum of 6 in. (15.24 cm) from the inside of the door. The front and rear doors of the cabinet must be perforated with a minimum open area of 70%.

Following figure shows the clearances required for installation of Cisco 8600 Series Routers.

Figure 14: Clearances Required Around the Chassis

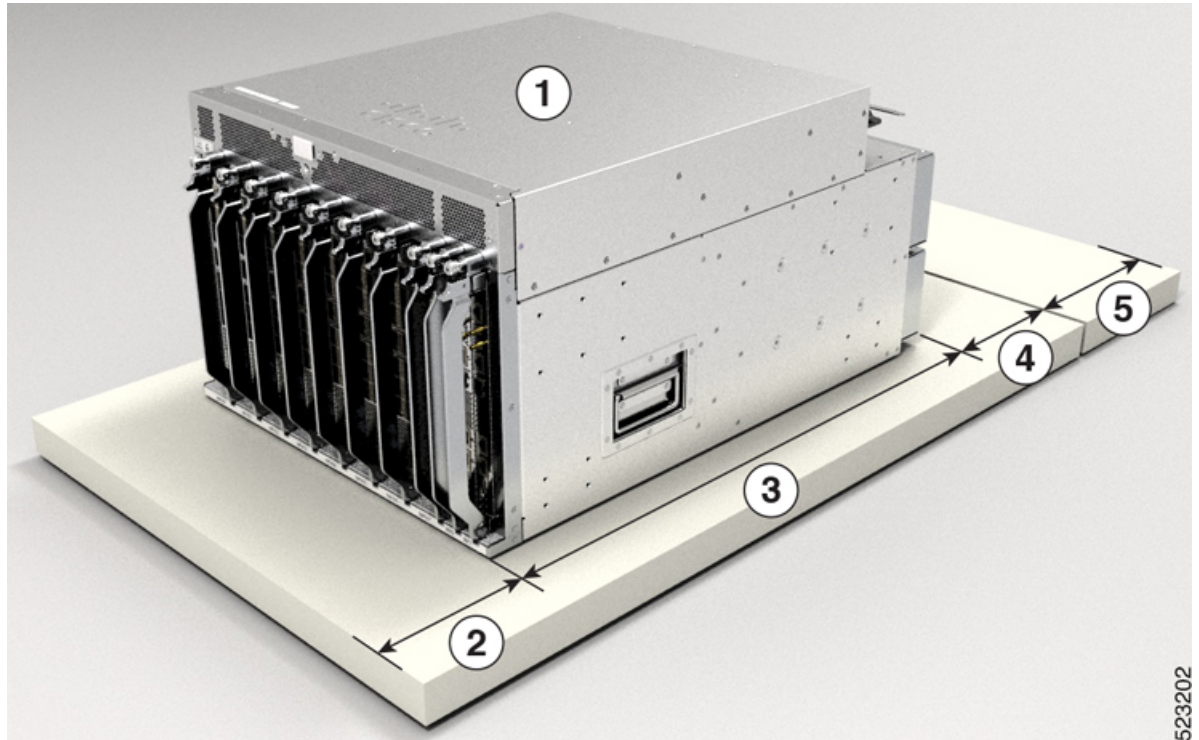

1	Chassis	4	Clearance required in rear of the chassis for air exhaust
2	Clearance required in front of the chassis for air intake	5	Rear service area for the fan tray and switch card replacement
3	Chassis depth		



CHAPTER 3

Unpack and Install the Chassis



Note The images in this chapter are only for representation purposes, unless specified otherwise. The chassis' actual appearance and size may vary.

- [Unpack the Chassis, on page 27](#)
- [Install Bottom-Support Rails, on page 29](#)
- [Transfer Chassis to a Mechanical Lifting Device, on page 30](#)
- [Mount Chassis Into the Rack, on page 32](#)
- [Installing a Cable Management Bracket, on page 38](#)
- [Attach Door Kit to Chassis, on page 39](#)

Unpack the Chassis



Tip Ensure that you save the packaging in case you need to return any of the router components. For more information about returns, see [Discrepancies or Damage?](#), on page 22.

Ensure that there is sufficient room around the chassis pallet for unpacking. For information about the chassis dimensions and clearance requirements see, *Clearance Requirements*.

Carefully move the pallet containing the chassis to the staging area where you plan on unpacking it.

Figure 15: Move the Chassis Pallet to Staging Area

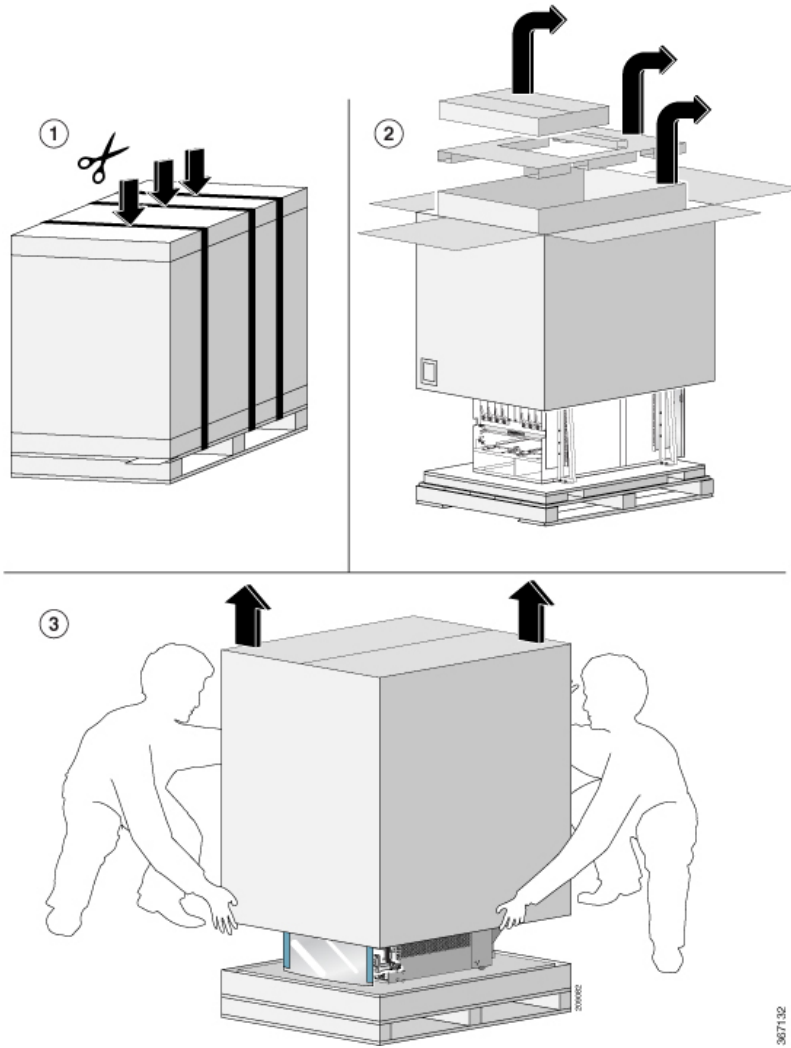

967132

Figure 16: Remove Shipping Brackets from 8608 Chassis

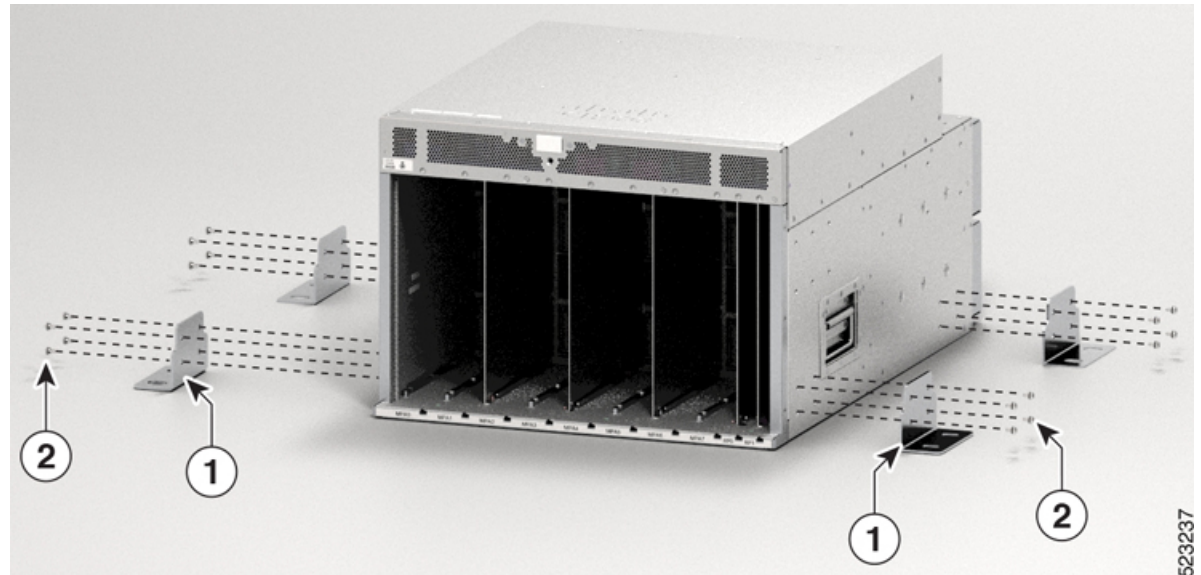

1	Shipping brackets
2	M4 x 6-mm Phillips flat-head screws (16)

Remove the 16 x M4 screws from the 8608 chassis and remove the shipping brackets.

To make the chassis weigh less for moving, remove the following module and place them where their connectors will not be damaged:

- Switch Cards

Leave the chassis on the pallet until you are ready to move and install the chassis in a rack.

What to do next:

Attach bottom support rails to the chassis

Install Bottom-Support Rails

The bottom-support rails support the weight of the router chassis in the rack. To maximize the stability of the rack, you must attach these rails at the lowest possible rack unit (RU).

Procedure

Step 1 Position the vertical rack rails at 32" depth to match with the length of the bottom-support rails. Check spacing considerations.

- Maintain at least 16 RU (28 inches [71.12 cm]) for 8608 chassis of vertical space above support rails.

- Step 2** Attach the bottom-support rail to the rack by using a Phillips torque screwdriver. Use the M6 x 19 mm or 12–24 x 3/4 inch screws for each end of the bottom-support rails and tighten each screw to 40 in-lbs (4.5 N-m) of torque.

Figure 17: Attach Bottom-Support Rails to Rack

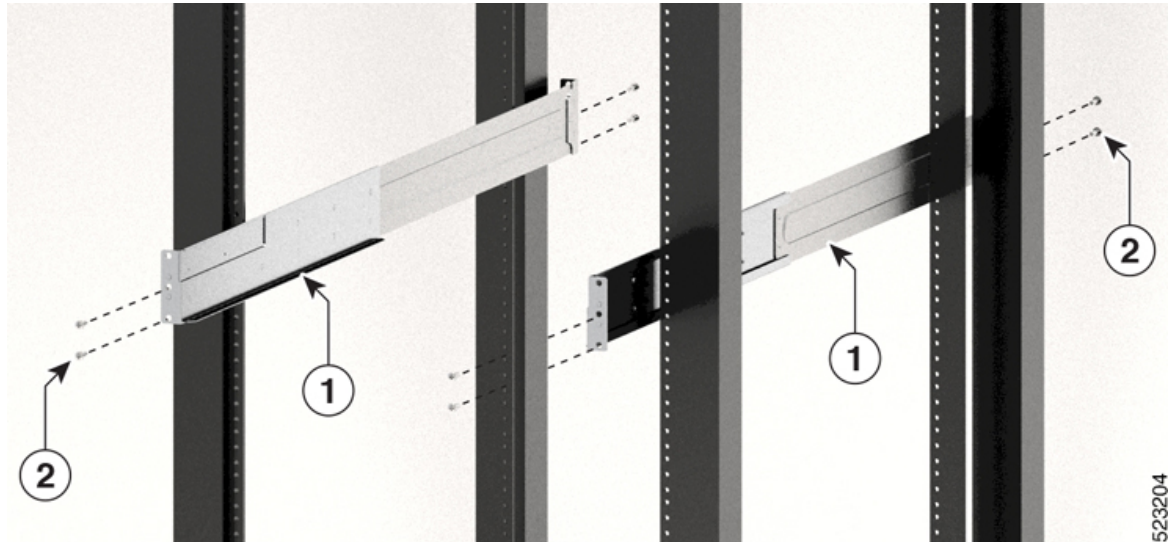

1	Bottom-support rails
2	M4 x 6-mm Phillips flat-head screws (8)

Note Use two screws on each end of each bottom-support rail.

- Step 3** Repeat Steps 1 and 2 to attach the other bottom-support rail to the rack.

Note Ensure that the two bottom-support rails are level with one another. If they are not level, adjust the higher rail down to the level of the lower rail.

What to do next

Transfer chassis to a mechanical lifting device.

Transfer Chassis to a Mechanical Lifting Device

Procedure

- Step 1** Place the mechanical lifting device in front of the chassis on the pallet (or on Line Card side) as shown.

Figure 18: Align the Lifting Device in Front of the Chassis on the Pallet



- Step 2** Prepare to use the mechanical lifting device by placing a piece of cardboard on the surface of the lift (to prevent scratching).
- Step 3** With at least two or three people move the chassis carefully from the pallet onto the lifting device as shown.

Figure 19: Move the Chassis on to the Lifting Device

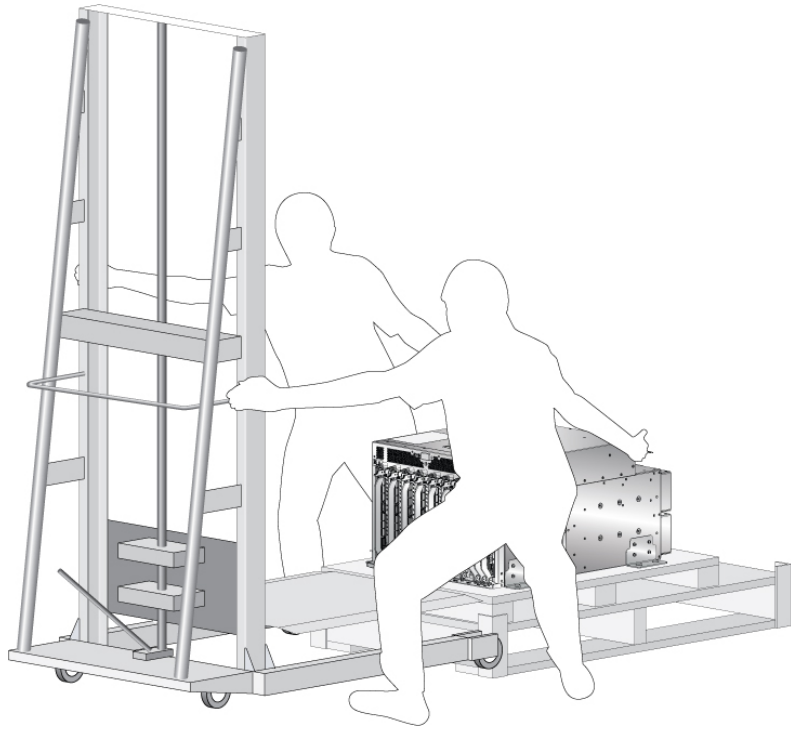

What to do next

After moving the chassis to the room or area where you will install it, begin the procedure to mount the chassis into the rack.

Mount Chassis Into the Rack

This section describes how to install the router in a 4-post rack.

The following table lists the items that are contained in the rack-mount kit.

Table 7: Rack-Mount Kit (8608-RMBRKT)

Quantity	Part Description
8	Rack-mount brackets
20	M4 x 6-mm Phillips flat-head screws
1	Grounding lug and screws

To accommodate equipment racks with different mounting hole patterns, the chassis mounting brackets have groups of screw holes on either side. The mounting holes in the chassis mounting brackets are spaced so that one mounting hole in each hole group aligns with a corresponding hole in the equipment rack. By using the

corresponding mounting hole (in the same hole group) on the opposite side of the chassis, you can level the chassis in the rack.



Note To lift the chassis, use a mechanical lift. Do not use the handles on the side of the chassis. Use the side handles only for repositioning the chassis after it is already on the mechanical lift or in the rack or cabinet.



Warning **Statement 1032**—Lifting the Chassis

To prevent personal injury or damage to the chassis, never attempt to lift or tilt the chassis using the handles on modules, such as power supplies, fans, or cards. These types of handles are not designed to support the weight of the unit.



Warning **Statement 164**—Lifting the Chassis

2 people are required to lift the heavy parts of the product. To prevent injury, keep your back straight and lift with your legs, not your back.



Warning **Statement 1006**—Chassis Warning for Rack-Mounting and Servicing

To prevent bodily injury when mounting or servicing this unit in a rack, you must take special precautions to ensure that the system remains stable. The following guidelines are provided to ensure your safety:

- This unit should be mounted at the bottom of the rack if it is the only unit in the rack.
 - When mounting this unit in a partially filled rack, load the rack from the bottom to the top with the heaviest component at the bottom of the rack.
 - If the rack is provided with stabilizing devices, install the stabilizers before mounting or servicing the unit in the rack.
-



Warning **Statement 1047**—Overheating Prevention

To reduce the risk of fire or bodily injury, do not operate the unit in an area that exceeds the maximum recommended ambient temperature of: 104°F (40°C)



Note Do not use the rack-mount brackets as slide rails. You must secure the rack-mount brackets only for removal and replacement of chassis.

Procedure

- Step 1** Install the ear brackets to the sides of the chassis. Use the M4 x 6-mm Phillips flat-head screws to 26 in-lbs (2.93 N-m) of torque to fix the ear brackets to the chassis.

Figure 20: Install Ear Brackets to Sides of the Chassis

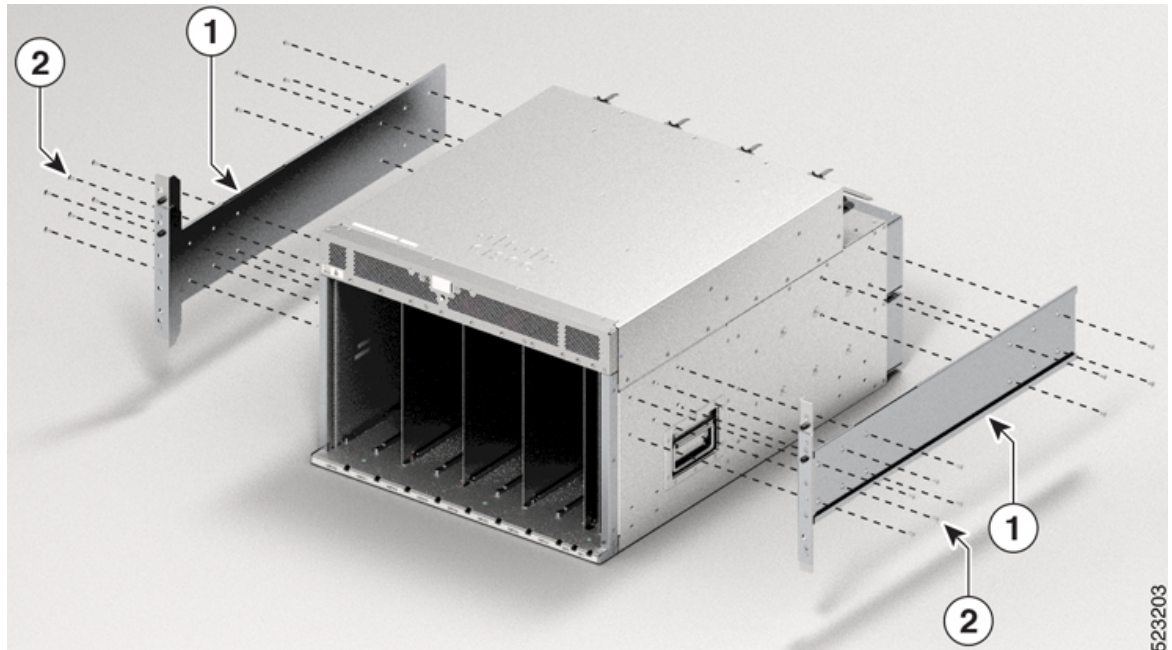

1	Ear brackets
2	M4 x 6-mm Phillips flat-head screws

- Step 2** Using your mechanical lift, raise the chassis so that it is in level with or not more than 1/4 inch [0.635cm] above the rails.
- Step 3** Push the chassis all the way onto the rack so that the vertical mounting brackets on the front of the chassis come in contact with the vertical mounting rails on the rack.
- Step 4** Use screws provided with the rack to secure the chassis with the vertical mounting rails on the rack. Use 12 screws in the front side and 8 screws in the rear side to secure the chassis on to the rackmount.

Figure 21: Attach 8608 Chassis to Rack - Front view

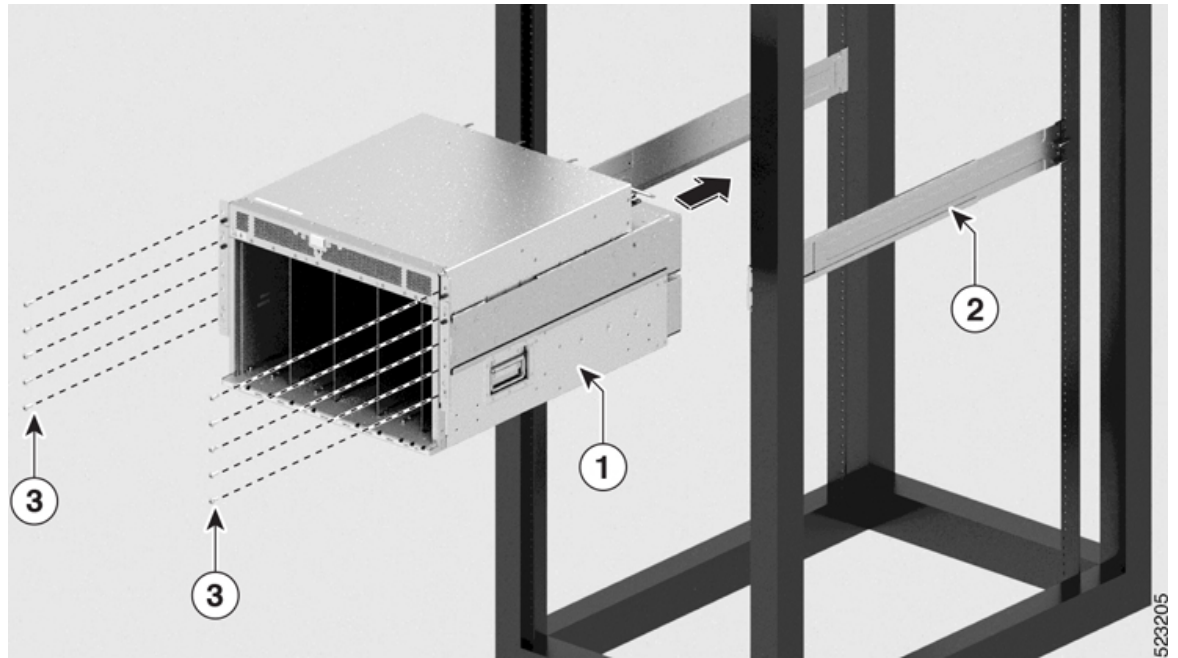

1	Chassis	2	Bottom rails
3	M4 x 6-mm Phillips flat-head screws (10)		

Step 5 Use the screws provided with the rack to attach the chassis rear rails. Install screws from outside the chassis to tighten each screw to 26 in-lbs (2.93 N-m) of torque. Four screws on each side of the chassis. Slide the rear brackets into the ear bracket that are attached to the chassis.

Figure 22: Attach 8608 Chassis to Rack - Rear View

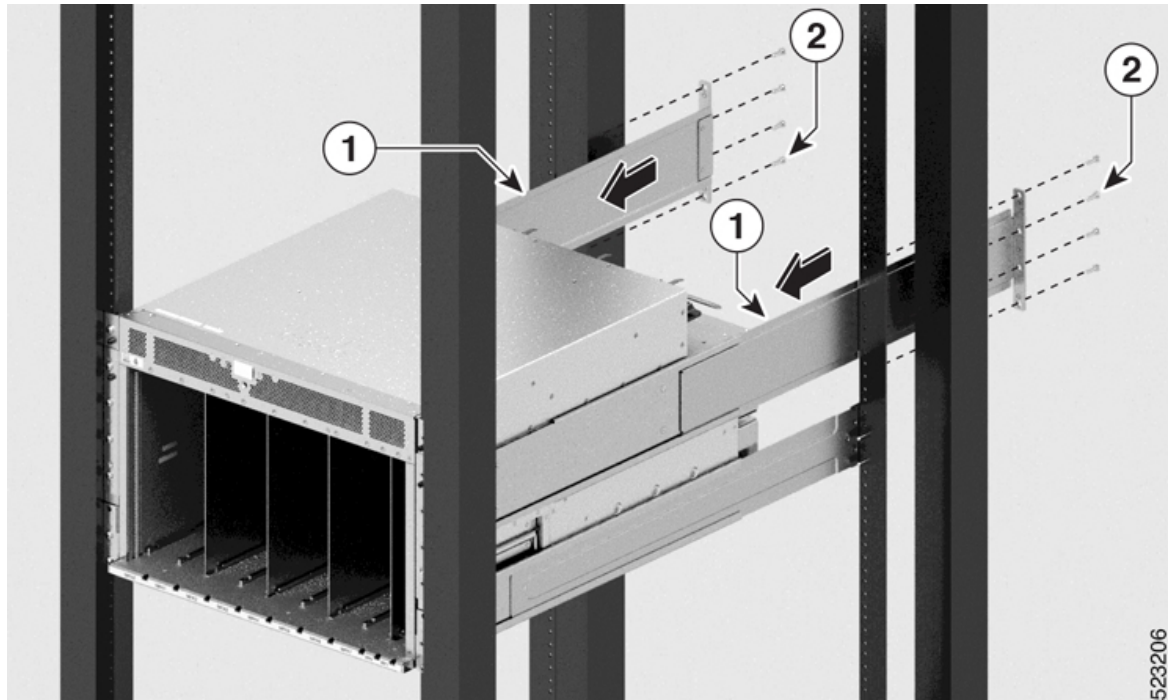

1	Rear rack mounting brackets.	2	M4 x 6-mm Phillips flat-head screws (8)
---	------------------------------	---	---

What to do next

Connect the chassis to the ground at your facility.

Locate and Ground the Chassis



Warning Statement 1024—Ground Conductor

This equipment must be grounded. To reduce the risk of electric shock, never defeat the ground conductor or operate the equipment in the absence of a suitably installed ground conductor. Contact the appropriate electrical inspection authority or an electrician if you are uncertain that suitable grounding is available.



Warning Statement 1101—Connected To Grounded Outlet

In the Scandinavian countries (Denmark, Finland, Iceland, Norway, and Sweden) the appliance must be connected to a grounded outlet.

Procedure

Step 1 Locate the chassis grounding receptacles on your router chassis.

You can locate them at the following position:

- At the left side panel, lower section towards the rear

Step 2 Use the wire stripper to strip one end of the 2-AWG wire approximately 0.75 inches (19.05 mm).

Step 3 Insert the 2-AWG wire into the wire receptacle on the grounding lug.

Figure 23: Chassis Ground Receptacles on Cisco 8608 Chassis



1	Locate ground	2	Align the lug holes and tighten the screws
---	---------------	---	--

Step 4 Use the crimping tool to carefully crimp the wire receptacle around the wire; this step is required to ensure a proper mechanical connection.

Step 5 Insert the two screws through the holes in the grounding lug. Ensure that the grounding lug does not interfere with other router hardware components.

Step 6 Use the Phillips screwdriver to carefully tighten the screws to 60 in-lbs 6.7 (N-m) of torque until the grounding lug is held firmly to the chassis. Do not overtighten the screws.

Step 7 Connect the opposite end of the grounding wire to the appropriate grounding point at your site to ensure an adequate chassis ground.

What to do next

Install cable management brackets.

Installing a Cable Management Bracket

To install a cable-management bracket, follow these steps:



-
- Note**
- This procedure is applicable for Cisco 8608 chassis.
 - The cable management brackets for Cisco 8608 chassis supports only optics cables.
-

Before you begin

The chassis must be installed and secured to the rack.

Required tools and equipment:

- Phillips screwdriver with a torque capability (customer supplied)
- Cable management brackets (8608-CBLMGMT).



-
- Note**
- The cable management brackets are shipped with the chassis.
 - The cable management bracket comes with a top hood.
-

Procedure

- Step 1** Insert the alignment pins on top of the chassis.
- Step 2** Position the top hood of the cable management assembly with its brackets pointing down.
- Step 3** After you finish the alignment of the top hood with the chassis, secure it with counter sink screws and M4 x 18-mm screws.

Figure 24: Cable Management Brackets for 8608 Chassis

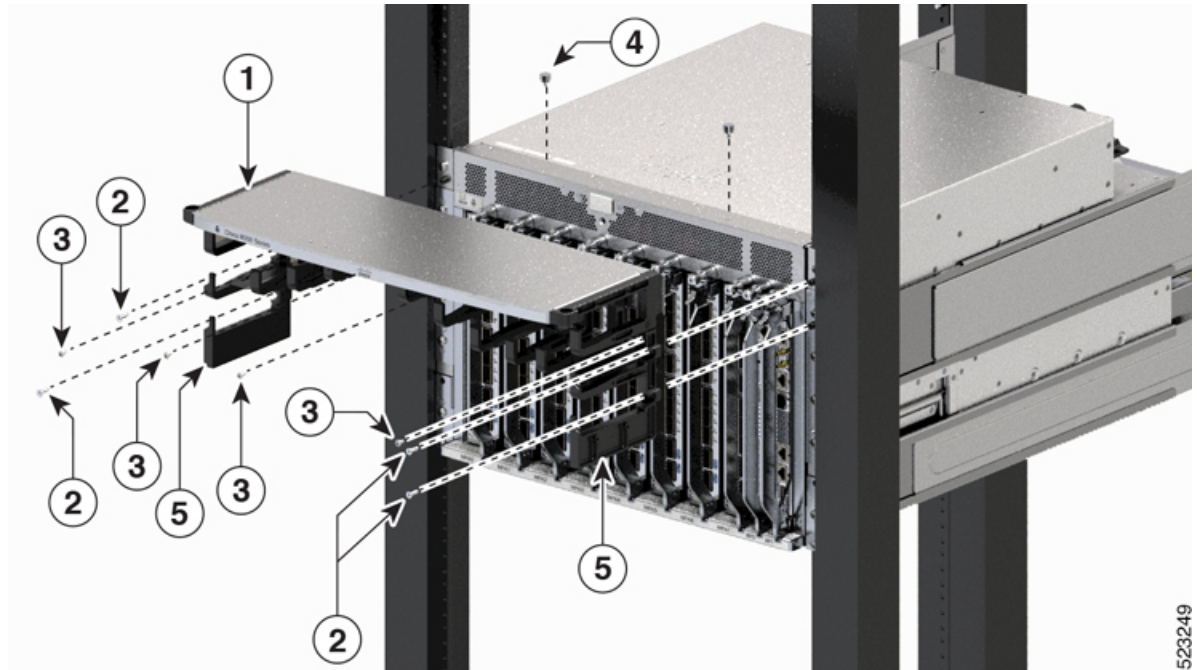

1	Top hood. The top hood and cable management brackets are one unit.	2	Counter sink screws
3	M4 x 18-mm Phillips flat-head screws	4	Alignment pins
5	Cable management brackets. The top hood and cable management brackets are one unit.		

What to do next

Attach door kit to the chassis.

Attach Door Kit to Chassis

Before you begin

Before you can attach the front door to the chassis, you must attach the cable management brackets and bottom plate onto the chassis.

Required tools and equipment:

- Phillips screwdriver with a torque capability (customer supplied)
- Door kit (8608-DRKT)



Note The door kit is optional.

Procedure

Step 1

After you've installed the cable management brackets onto the chassis, secure the left and right door brackets to the chassis vertical mounting brackets with flat-head Phillips screws M4 x 18-mm screws (use all screws provided in the kit). Insert one screw at the top and one at the bottom, likewise add more screws in this sequence. The number of screws may vary based on the chassis.

Figure 25: Secure Left and Right Door Brackets

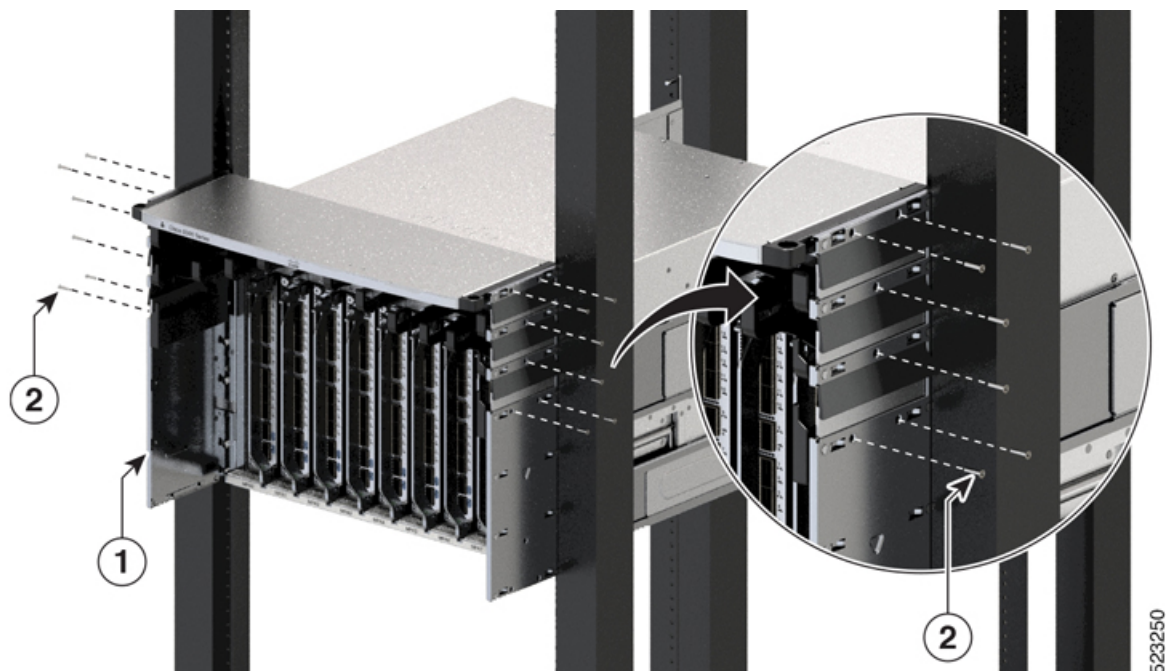

Step 2

Position the bottom cover with its brackets pointing up, to the bottom of the two sides (right and left) of the door bracket screw holes.

Figure 26: Bottom Cover for 8608 Chassis

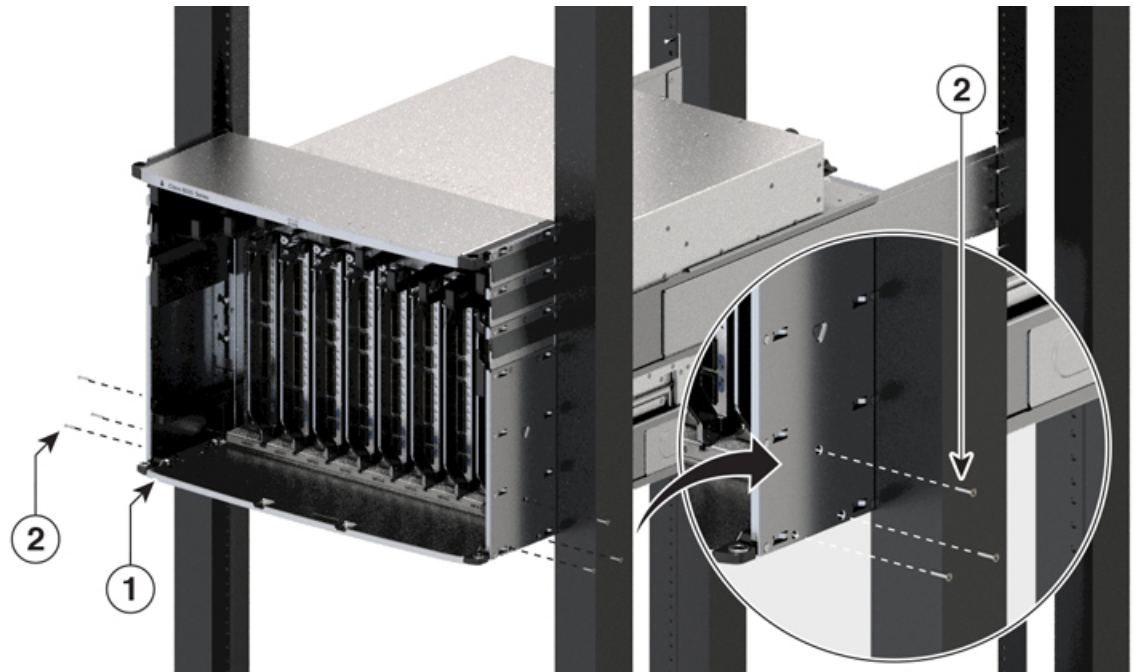

1	Bottom cover
2	M4 x 6 mm pan-head Phillips screws

- Step 3** Secure the bottom cover to the door brackets by using four M4 x 6 mm pan-head Phillips screws. Tighten each screw to 11.5 to 15 in-lb (1.3 to 1.7 N·m) of torque.
- Step 4** Tighten the door brackets screws to 11.5 to 15 in-lb (1.3 to 1.7Nm) of torque after completing the bottom cover installation.

Attach Front Door to Chassis

Procedure

- Step 1** On the back side (open side) of one door, pull in on two protruding spring pins so that the pins are held inside the door frame.

Figure 27: Front Door Pins

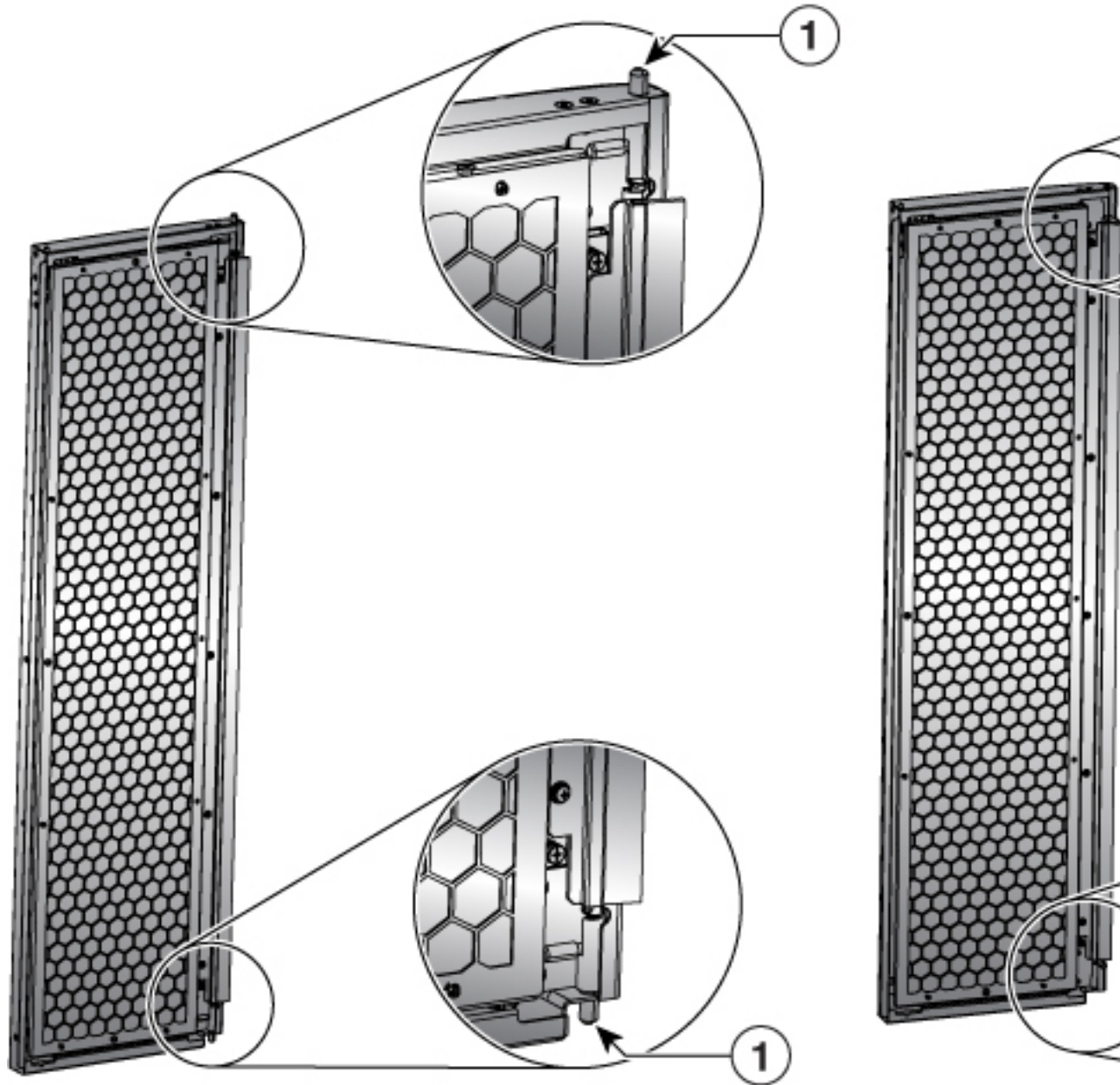

1	Front door spring pins
---	------------------------

Step 2 Align the spring pin to the hole in the bottom plate and release the spring pin, so that they insert into the bottom hole.

Step 3 Now align the spring pin to hole in the top hood and release the spring pin.

Step 4 Ensure the pins are properly inserted into the holes so that the door can freely swing on the spring pins.

Figure 28: Front Door Attached to 8608 Chassis

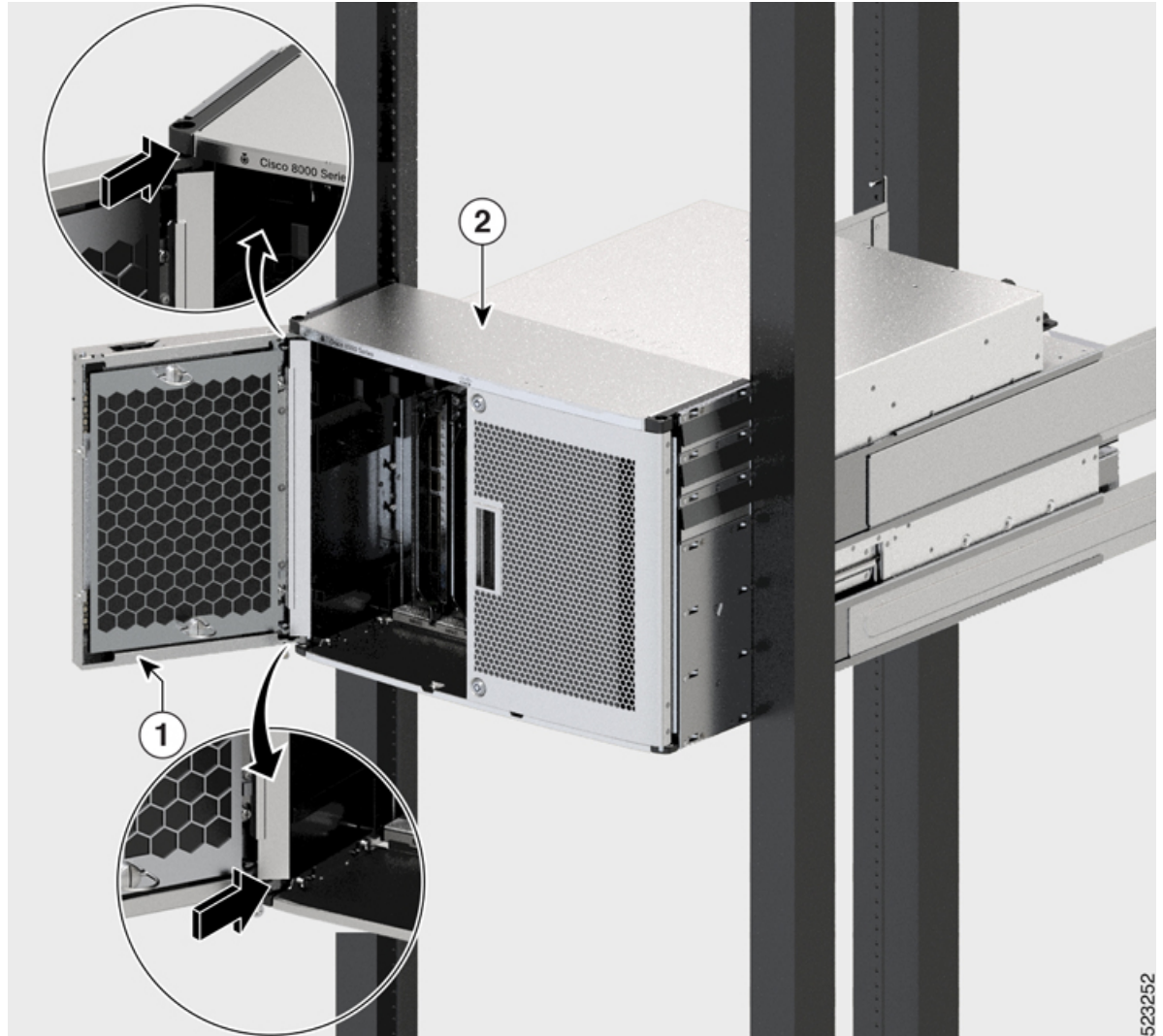

1	Front door	2	Top hood
---	------------	---	----------

Step 5 Repeat Steps 2–5 to install the other front door.

Figure 29: Doors Attached to the Chassis

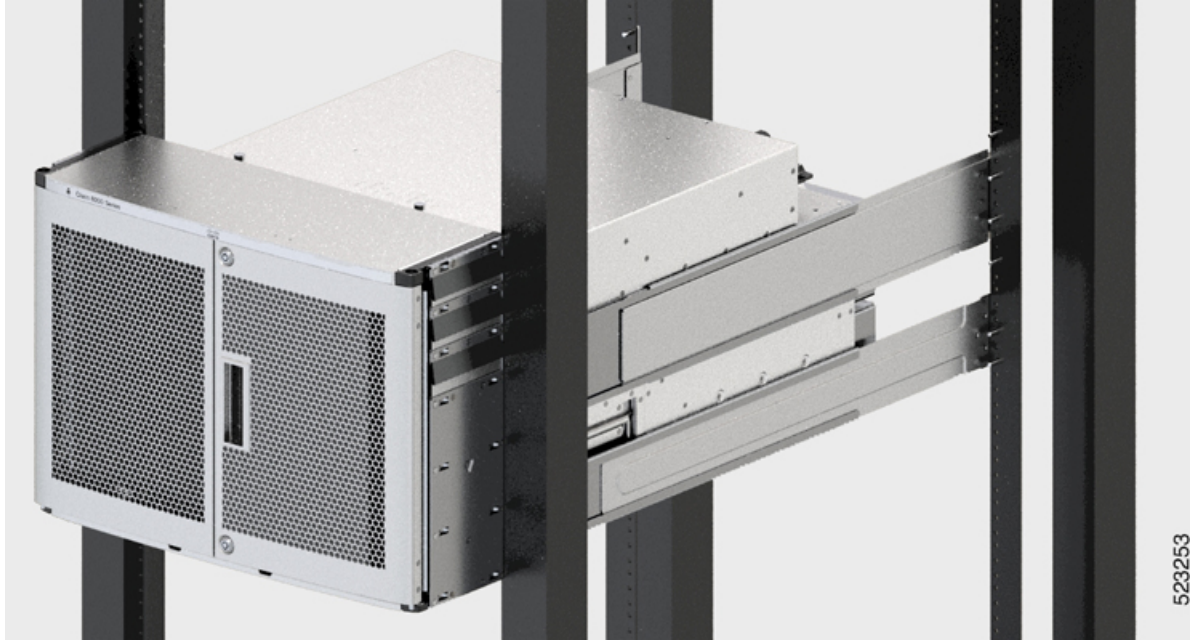



CHAPTER 4

Powering on the Router

This chapter describes how to connect the power modules in the chassis and to power on the router.

- [Power Supply Overview, on page 46](#)
- [Power Connection Guidelines for AC-Powered Systems, on page 47](#)
- [Power Supply Unit Input and Output Ranges, on page 49](#)
- [Connect AC Power to the Chassis, on page 50](#)
- [Connect a DC Power Supply to the Chassis, on page 59](#)
- [Power Supply Power Cord Specifications, on page 67](#)

Power Supply Overview

Table 8: Feature History Table

Hardware	Release Information	Description
PSU4.3KW-HVPI Power Supply Unit for Cisco 8608 Router	Release 24.2.1	<p>We're now introducing a high voltage power supply unit, PSU4.3KW-HVPI that accepts HVAC or HVDC input power to operate the Cisco 8608 router in the port side intake configuration. The PSU4.3KW-HVPI power supply unit has a dual input redundant power supply with 55V (main) and 3.3V (standby) outputs.</p> <p>The benefits of the PSU4.3KW-HVPI power supply unit are:</p> <ul style="list-style-type: none"> • Supports HVDC and HVAC input power • Helps when high power transceivers are installed in the router which need more power to operate • Provides better efficiency for power distribution

You can install up to four 3.2KW or 4.3KW HVAC/HVDC power supplies in the chassis. Ensure that all power connection wiring conforms to the rules and regulations in the National Electrical Code (NEC) and in local codes.



Note

- The Cisco 8608 chassis doesn't support a mix of AC and DC Power Supply Units (PSUs).
- The Cisco 8608 chassis doesn't support a mix of 3.2 KW and 4.3 KW PSUs.

Power Module Specifications

Power Module	Single/Dual Input	Nominal Input Voltage Range	Full Range
PSU3.2KW-ACPI	The AC power modules are single feed input with 3.2KW capacity at 220V. They also support operation at 110V with half the capacity of 1570W. AC power modules are rated at 3.2KW maximum at 230V AC high line input, and 1570W maximum at 115V AC low line input.	100—120V AC 200—240V AC	85—300V AC
PSU3.2KW-DCPI	The DC power modules are dual feed input with 3.2KW capacity at any specified input voltage. DC power modules with single feed at any specified input voltage provide up to 1.6KW maximum capacity.	-48 to -60V DC	-40 to -75V DC
PSU4.3KW-HVPI	The AC power modules are dual feed with 4.3KW capacity at 220V. They also support operation at 110V with reduced capacity of 1570W for single input configuration. The 4.3KW-HVPI PSUs shall operate within specification from 85V—305VAC or 192—400V DC continuously.	100—120V AC 200—240V AC 265—305V AC 192—219V DC 220—289V DC 290—400 V DC	85—305V AC 192—400V DC

Power Connection Guidelines for AC-Powered Systems

When connecting AC-input Power Supply Units (PSUs) to the site power source, observe the guidelines described here.



Warning Statement 1028—More Than One Power Supply

This unit might have more than one power supply connection. To reduce risk of electric shock, remove all connections to de-energize the unit.

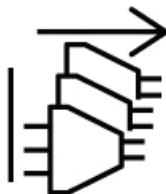

- Ensure that the AC-input power supply module has a detachable power cord.
- Each chassis power supply should have a separate, dedicated branch circuit.
 - North America
 - PSU3.2KW-ACPI only—Power supply modules require a 20 A circuit.
 - International—Circuits should be sized according to local and national codes.
- If you are using a 208 or 240 VAC power source in North America, note that such lines are considered hot and the circuit must be protected by a two-pole circuit breaker.



Warning **Statement 1005**—Circuit Breaker

This product relies on the building's installation for short-circuit (overcurrent) protection. To reduce risk of electric shock or fire, ensure that the protective device is rated not greater than:

-
- 20 A circuit breaker for an AC-input power supply module.
 - 50 A DC-rated circuit breaker for each input of a DC-input power supply module, for safety purposes - irrespective of whether the inputs are power from a single or separate DC sources.



Warning This product requires short-circuit (overcurrent) protection, to be provided as part of the building installation. Install only in accordance with national and local wiring regulations. **Statement 1045**



Warning **Statement 1022**—Disconnect Device

To reduce the risk of electric shock and fire, a readily accessible disconnect device must be incorporated in the fixed wiring.

-
- The source AC outlet must be within 9.84 to 14 feet (3.0 to 4.293 meters) of the system - depending on the length of the power cord, and should be easily accessible.
 - The AC power receptacles used to plug in the chassis must be the grounding type. The grounding conductors that connect to the receptacles should connect to protective earth ground at the service equipment level.

Power Supply Unit Input and Output Ranges

Power Supply Restrictions and Considerations



Warning Statement 1090—Installation by Skilled Person

Only a skilled person should be allowed to install, replace, or service this equipment. See statement 1089 for the definition of a skilled person.

There are no serviceable parts inside. To avoid risk of electric shock, do not open.



Warning Statement 1091—Installation by an Instructed Person

Only an instructed person or skilled person should be allowed to install, replace, or service this equipment. See statement 1089 for the definition of an instructed or skilled person.

There are no serviceable parts inside. To avoid risk of electric shock, do not open.



Warning Statement 1073—No User-Serviceable Parts

There are no serviceable parts inside. To avoid risk of electric shock, do not open.

Observe the following guidelines and limitations:

- Use one type of power supply in a router.
- The power supply type that is used in the router depends on the type and configuration of the transceivers installed in it.
- Do not install a mix of AC and DC power supplies in a router.
- The airflow direction must be the same for all power supply and fan modules in the router.
- The AC-input power supplies support low-line voltage of 120V (Nominal) and high-line voltage of 220V (Nominal). If you need to change voltage type after installation, disconnect the feed from the power supply before switching the input voltage level.

This table summarizes the list of power supplies' input and output power ranges for different input applications:

Table 9: Input and Output Power Ranges at Low Line, High Line, Low Voltage, and High Voltage Applications

Power Supply Unit PIDs	Supported Routers	Input Voltage	Input Current (Max)	Output Power (Single/Dual Input)
PSU3.2KW-ACPI For low line applications	Cisco 8608	100V AC – 115V AC	20A	1570W

Power Supply Unit PIDs	Supported Routers	Input Voltage	Input Current (Max)	Output Power (Single/Dual Input)
PSU3.2KW-ACPI For high line applications	Cisco 8608	180V AC – 300V AC	20A	3200W
PSU3.2KW-DCPI For low line applications	Cisco 8608	-48V DC – -60V AC	55A	1600W
PSU3.2KW-DCPI For high line applications	Cisco 8608	-40V DC – -75V AC	55A	3200W
PSU4.3KW-HVPI For AC low line applications	Cisco 8608	100V AC – 115V AC	20A	1570W/3130W
PSU4.3KW-HVPI For AC high line applications	Cisco 8608	180V AC – 305V AC	20A	3200W/4310W
PSU4.3KW-HVPI For HVDC applications	Cisco 8608	192V DC - 400V DC	20A	3200W/4310W



Note For more information on PSU specifications, see [Power Module Specifications](#).

Connect AC Power to the Chassis



Warning Statement 1017—Restricted Area

This unit is intended for installation in restricted access areas. Only skilled, instructed, or qualified personnel can access a restricted access area.



Warning Statement 1005—Circuit Breaker

This product relies on the building's installation for short-circuit (overcurrent) protection. To reduce risk of electric shock or fire, ensure that the protective device is rated not greater than:

AC: 20A, DC: 50A



Warning **Statement 1028**—More Than One Power Supply

This unit might have more than one power supply connection. To reduce risk of electric shock, remove all connections to de-energize the unit.

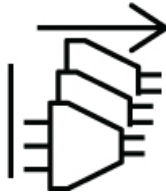

Warning **Statement 1003**—DC Power Disconnection

To reduce risk of electric shock or personal injury, disconnect DC power before removing or replacing components or performing upgrades.



Warning **Statement 1046**—Installing or Replacing the Unit

To reduce risk of electric shock, when installing or replacing the unit, the ground connection must always be made first and disconnected last.

If your unit has modules, secure them with the provided screws.



Warning **Statement 1022**—Disconnect Device

To reduce the risk of electric shock and fire, a readily accessible disconnect device must be incorporated in the fixed wiring.



Warning **Statement 1029**—Blank Faceplates and Cover Panels

Blank faceplates and cover panels serve three important functions: they reduce the risk of electric shock and fire, they contain electromagnetic interference (EMI) that might disrupt other equipment, and they direct the flow of cooling air through the chassis. Do not operate the system unless all cards, faceplates, front covers, and rear covers are in place.



Caution The chassis relies on the protective devices in the building installation to protect against short circuit, overcurrent, and ground faults. Ensure that the protective devices comply with local and national electrical codes.



Note We recommend that you occupy all power supply slots of the router with power supplies. In case a power module fails, it is recommended to retain the failed power module in its slot until it is replaced with a new power module. This recommendation ensures that the system airflow is not impacted adversely, which may then result in the overheating of the router and its components.



Note A dual pole breaker is needed for installation. For determining the recommended breaker size, please adhere to local and national rules and regulations. The breaker size is based on the specifications of the product for the current drawn and the specified voltage level.

Procedure

Step 1 Verify that the AC cable is installed in the correct AC source and outlet type.

Step 2 Set the AC-input power supply switch to the OFF (0) position.

Figure 30: Power Switch in Off Position - PSU3.2KW-ACPI



523363

1	Power supply in the OFF (0) position
---	--------------------------------------

Figure 31: Power Switch in Off Position - PSU4.3KW-HVPI



523989

1	Power supply in the OFF (0) position
---	--------------------------------------

Step 3

Grasp the power supply handle with one hand and place your other hand underneath to support the bottom of the PSU. Slide the PSU all the way into the power supply bay. Ensure that the PSU is fully seated in the bay. When correctly installed, the latch on the PSU locks-in the module, to avoid accidental removal of the module.

Figure 32: Slide the PSU into the Power Supply Bay - PSU3.2KW-ACPI

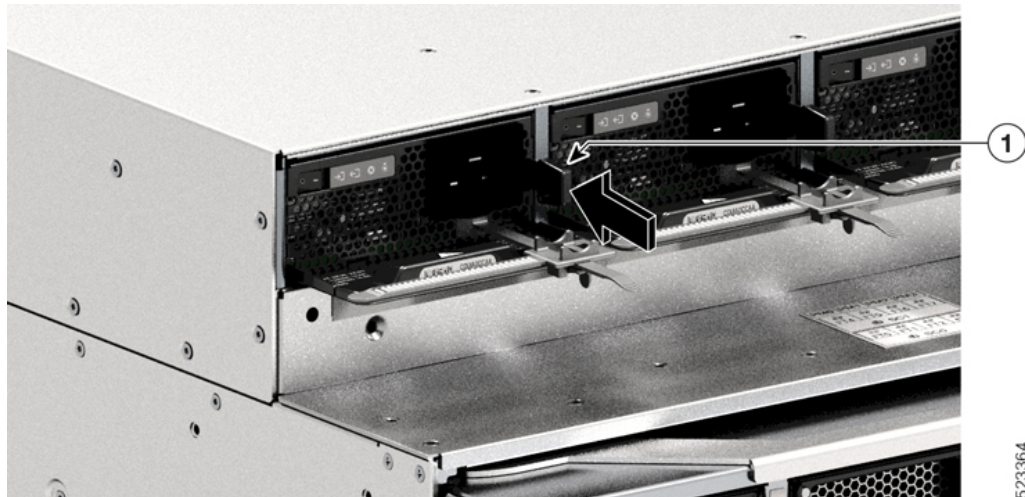

523364

1	Power supply latch, which clicks into place
---	---

Figure 33: Slide the PSU into the Power Supply Bay - PSU4.3KW-HVPI

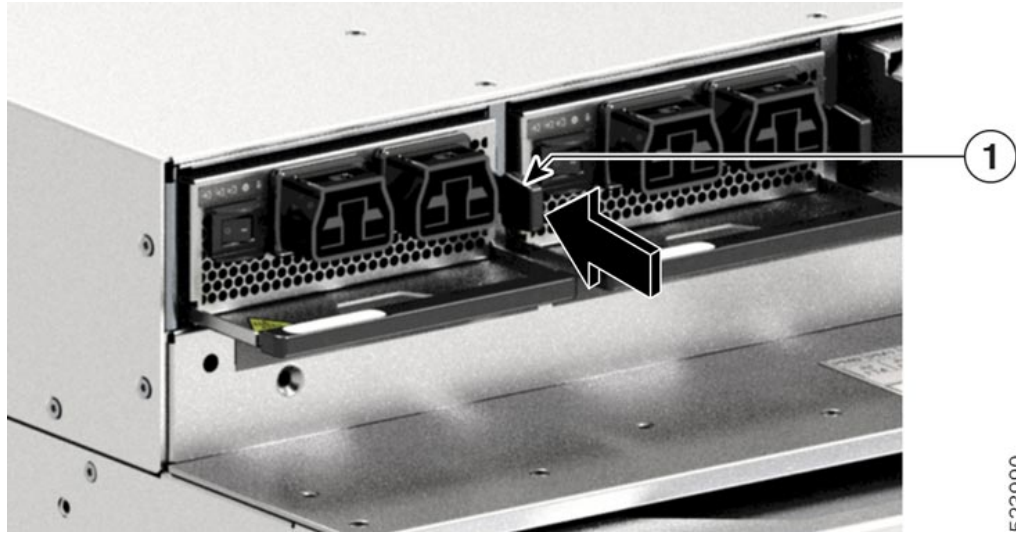

1	Power supply latch, which clicks into place
---	---

Step 4 Verify that all site power and grounding requirements have been met.

Step 5 Verify that you have the correct AC power cord for your location and power supply rating and only then plug the power cord connector into the power supply AC-in receptacle.

Figure 34: Plug Power Cord Connector into AC-in Receptacle - PSU3.2KW-ACPI

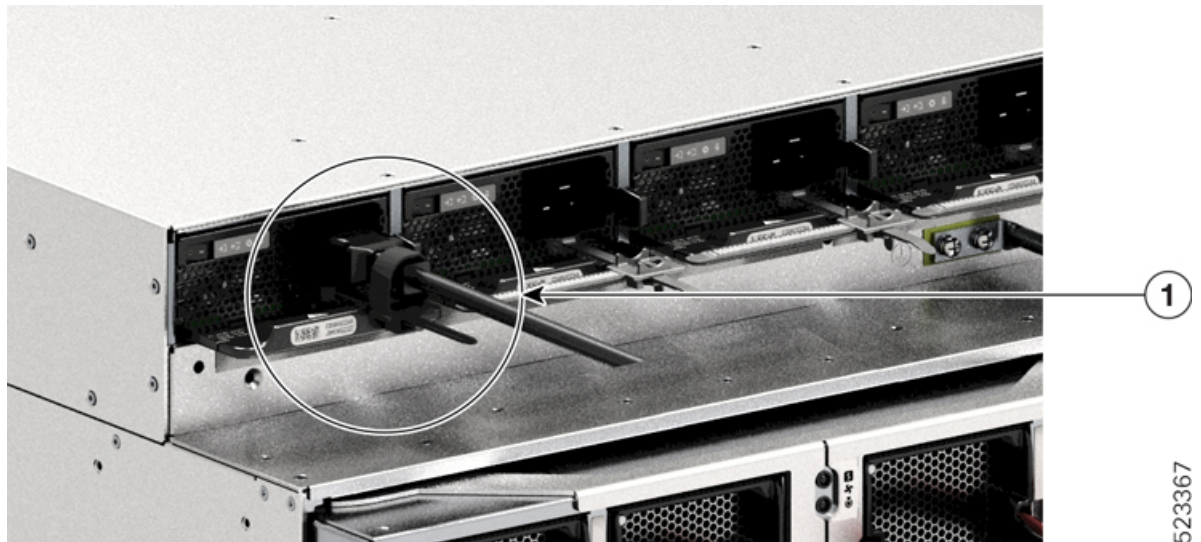

1	Power cord, plugged into the AC-in receptacle
---	---

Figure 35: Plug Power Cord Connector into AC-in Receptacle - PSU4.3KW-HVPI

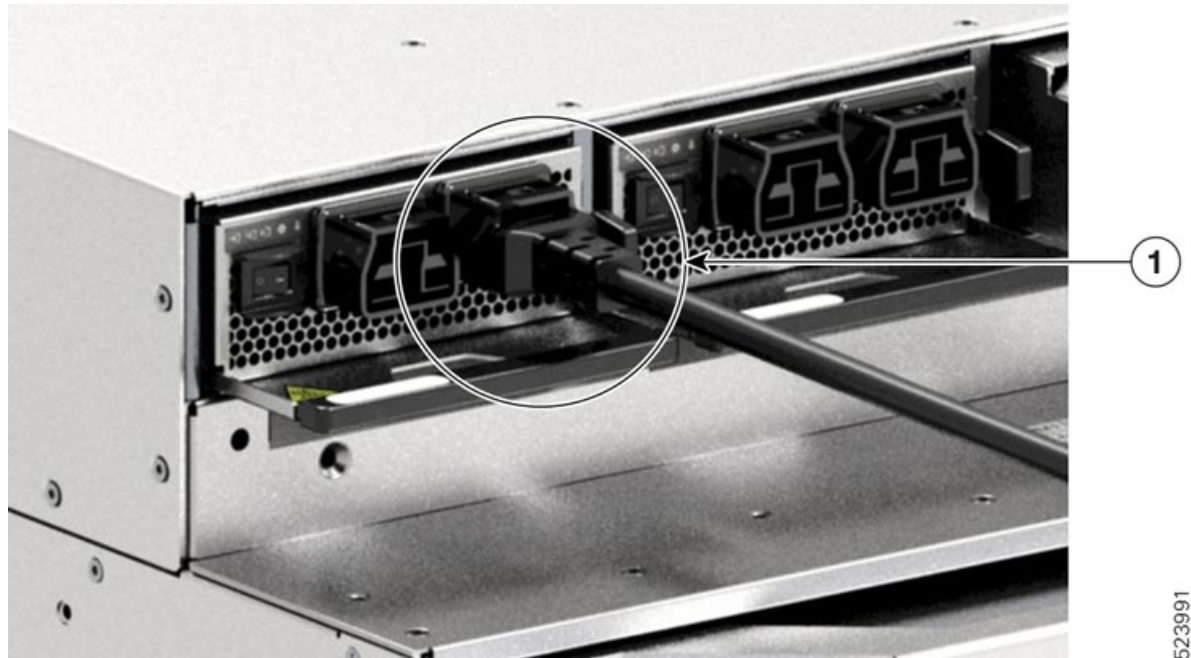

523991

1	Power cord, plugged into the AC-in receptacle
---	---

- Step 6** Strap in the power cord retainer, to hold it in place and avoid accidental removal. For more information, see [Power Cord Retainer Mechanism](#)
- Step 7** Set the power switch to the On (I) position

Power Cord Retainer Mechanism

This section shows how to correctly operate the power cord retainer, to tighten or loosen it while installing or removing the power supply unit.



Note Some of the illustrations do not include the power supply module, for the sake of clarity. The retainer is otherwise permanently fixed to the power supply module.

Figure 36: Parts of the Power Cord Retainer

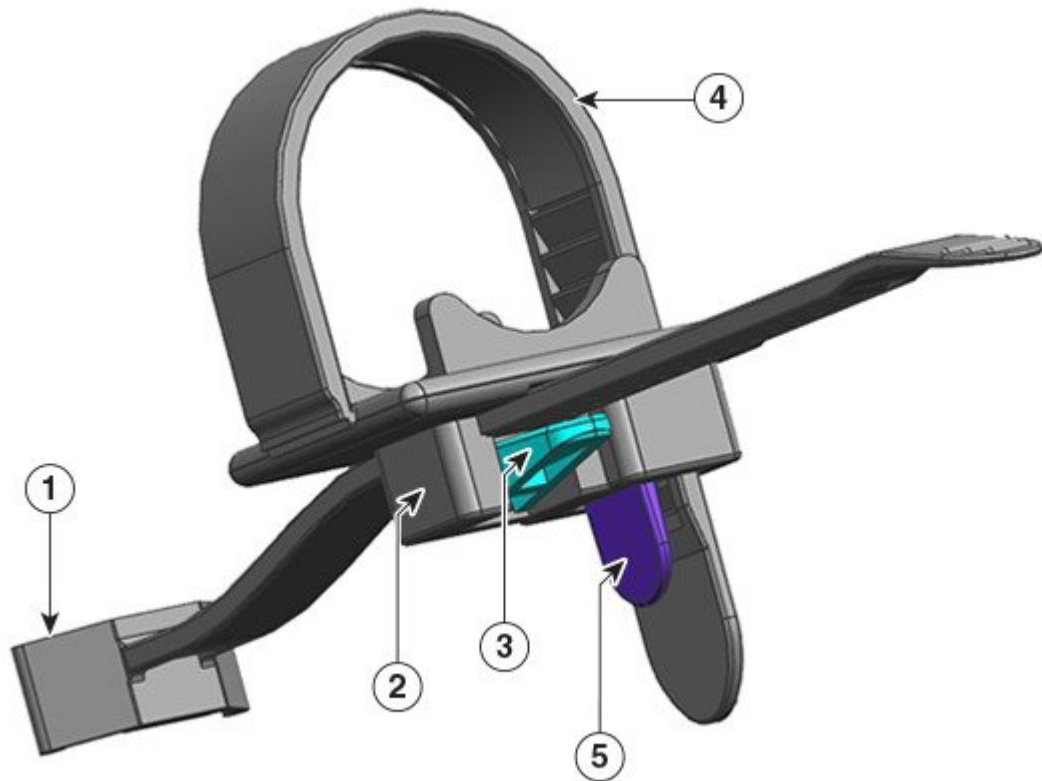

355187

1	The end that is fixed to the power supply unit	4	Flexible retainer strip
2	Clamp which can move towards the power supply or away from it	5	Retainer strip latch
3	Clamp latch		

Installation and Removal Sequence

Installation—After you have inserted the power supply unit into the bay, first position the clamp closest to the power supply, near the plug round cylinder stress relief and then insert the flexible retainer strip into the clamp hole and tighten. The clamp cannot be moved after the flexible retainer strip is inserted into the clamp hole.

Removal—After you have turned off the power supply unit's rocker switch, first remove the flexible retainer strip from the clamp hole and then adjust the position of the clamp to remove the power cord.

Positioning the Clamp

In figure, [Figure 37: Positioning the Clamp](#), the clamp can always move freely in direction 3a. To move the clamp in direction 3b, use a flathead screwdriver or similar device and push the clamp latch down. The figure,

Figure 38: **Clamp Latch - Detail**, provides a clearer view of the clamp latch and the direction in which you have to push the latch to move it in direction 3b.

Figure 37: Positioning the Clamp

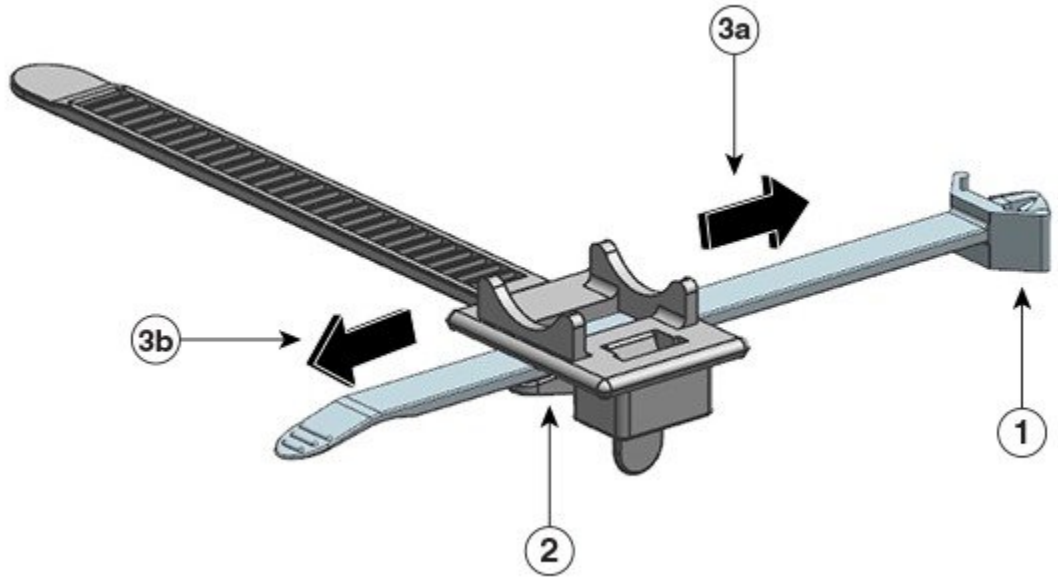

355312

1	The end that is fixed to the power supply unit	3a and 3b	Directions in which the clamp can be moved, towards the power supply and away from it.
2	Clamp Latch		

Figure 38: Clamp Latch - Detail

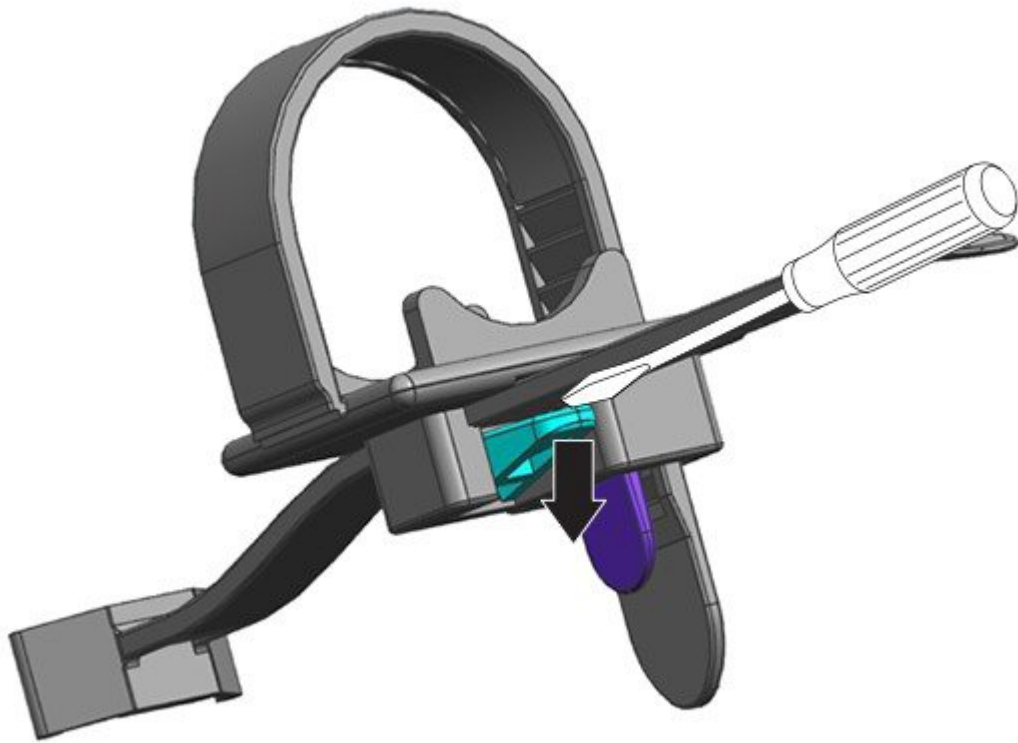

355189

Inserting and Tightening the Retainer Strip

The flexible retainer strip inserts into the clamp hole and should be tightened around the power cord.

To loosen or remove the flexible retainer strip, position a flathead screwdriver or similar device between the flexible retainer strip and the retainer strip latch and push the latch away from the flexible retainer strip.

Figure 39: Flexible Retainer Strip

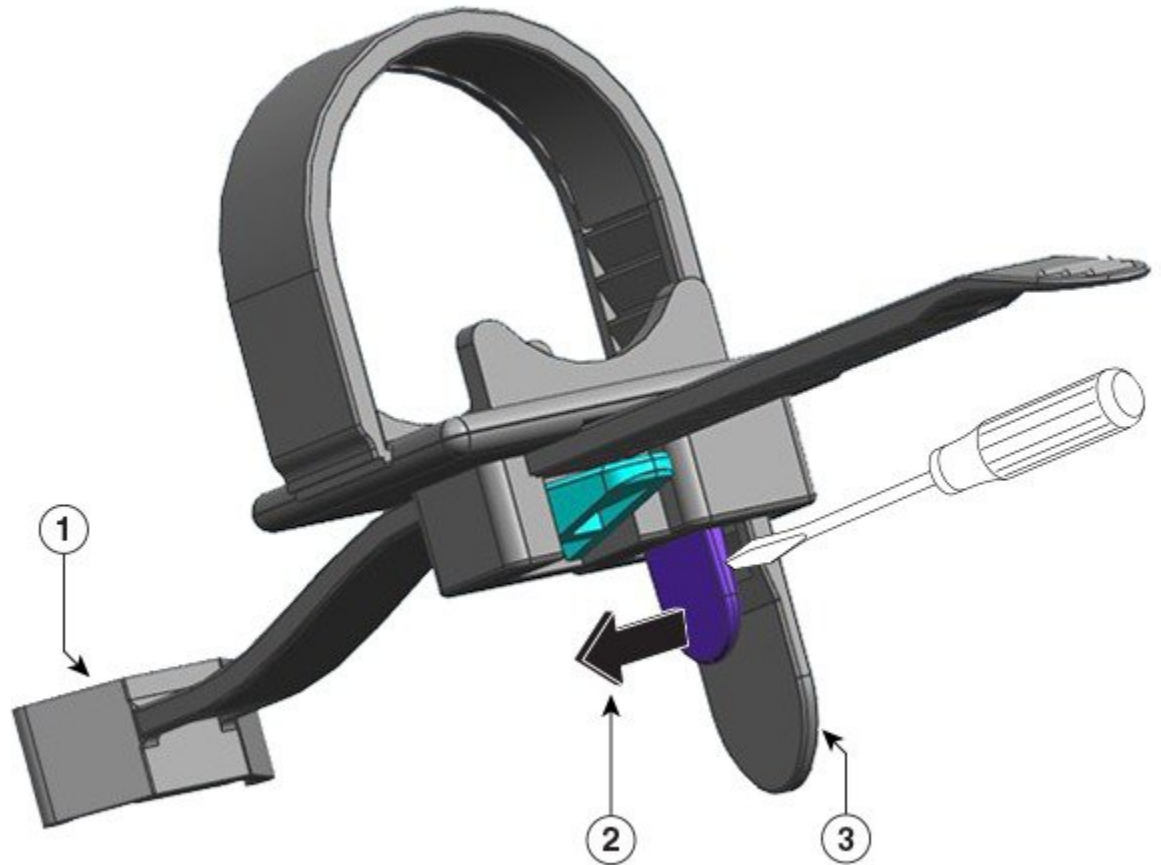

355188

1	The end that is fixed to the power supply unit.	3	Flexible retainer strip
2	Direction in which to push the retainer strip latch, to loosen or remove the strip from the power cord (away from the retainer strip that is behind it)		

Connect a DC Power Supply to the Chassis

When installing a DC-input Power Supply Unit (PSU), you will need access to the terminal block of the PSU in order to connect the DC-input wires. If the front panel of the chassis has limited access because of other interfering cables, consider connecting the DC-input wires to the terminal block, before you install the PSU in the chassis. If you do have clear access to the terminal block, you can install the PSU in the chassis first and then connect the DC-input wires.

The procedure to install the module in the chassis and the procedure to connect the DC-input wires have been described in [Connecting the DC-Input Wires, on page 63](#). You can complete either task first and then move on to the next, and finally power up the PSU.

Install a DC Power Supply Unit in the Chassis



-
- Note** The power button has two modes of operation, which are described below. Press the power button for 10 seconds to toggle between modes; the LOCATE LED blinks for three seconds when you do.
- **Auto-on:** When in this mode, the power supply module automatically starts or restarts on application or restoration of DC input power. This is the default mode.
For NEBS compliance, the power button must be in the auto-on mode. When power is restored after a power failure, the power supply module recovers automatically.
 - **Protected:** When in this mode, if the DC power source output voltage is zero, or drops out for more than three seconds, you must press the power button for two seconds, to restore operation.
-

To install a DC-input Power Supply Unit (PSU) in the chassis, follow the steps described here.

Before you begin



Warning **Statement 1073**—No User-Serviceable Parts

There are no serviceable parts inside. To avoid risk of electric shock, do not open.

Procedure

- Step 1** Remove the new or replacement unit from its packaging.
- Step 2** Grasp the module with one hand. With your other hand, push in the latch on the module.

Figure 40: Push the Latch on the Module

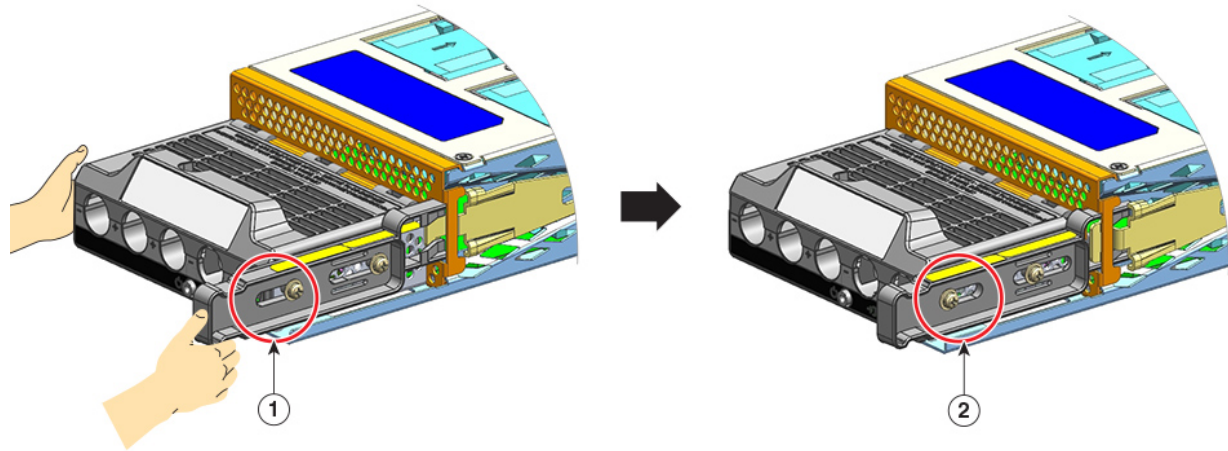

1	Position of the nut on the side of the release latch <i>before</i> the latch is pushed in	2	Position of the nut on the side of the release latch <i>after</i> the latch is pushed in.
---	---	---	---

Step 3

Grasp the terminal block with one hand. Place your other hand underneath as you slide the PSU into the bay. You will hear an audible *click* sound, which indicates that the module is locked into place, and connected with the backplane. Only the terminal block housing is not flush with the chassis.

If you do not push the release latch in before you slide the module into the bay, you will not hear the click sound, but this is an acceptable way of installing the module.

If the module is properly locked in place, you should not be able to remove the module without releasing the latch.

The following figure shows how a PSU slides into the bay:

Figure 41: PSU Slides into the Bay

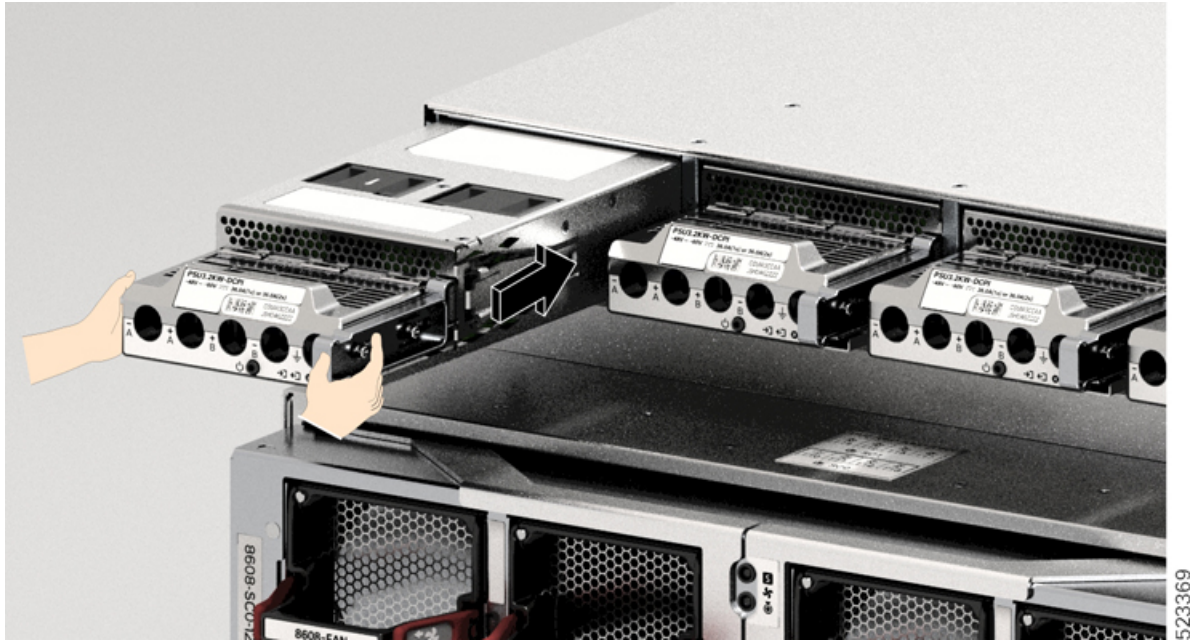

523369

The following figure shows a PSU that is fully installed in the bay:

Figure 42: PSU Installed in the Bay

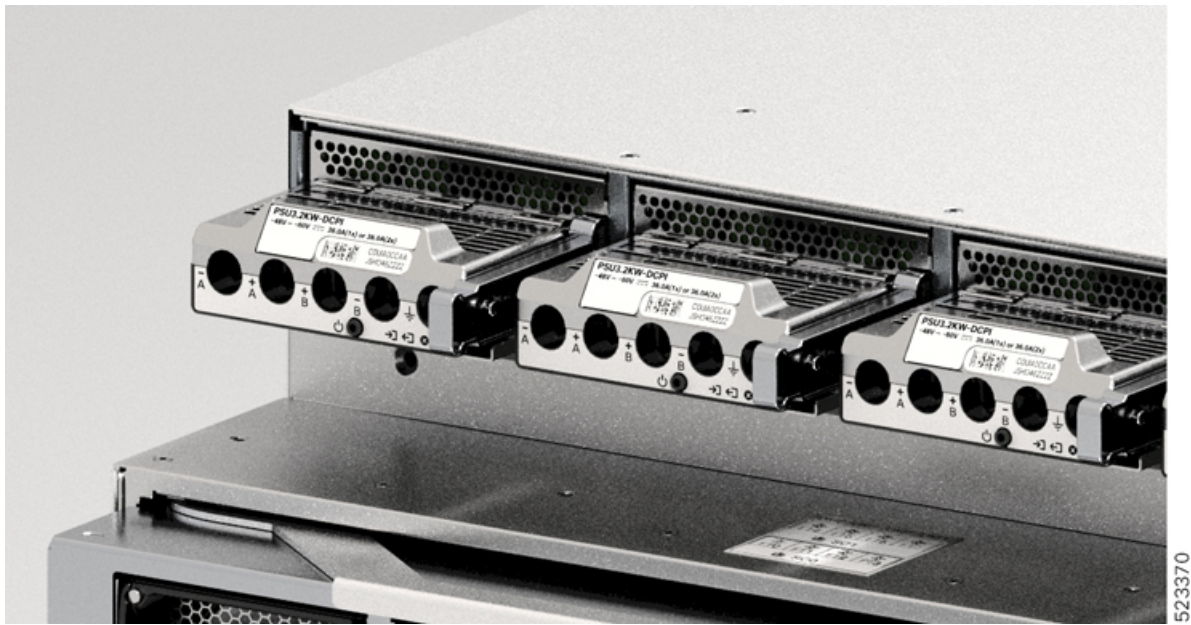

523370

Connecting the DC-Input Wires

When removing a DC Power Supply Unit (PSU), you will need access to the terminal block of the module to disconnect the DC-input wires. If the front panel of the chassis has limited access because of other interfering cables, consider removing the module from the chassis before disconnecting the DC-input wires. If you do have clear access to the terminal block, you can disconnect the DC-input wires and then remove the module from the chassis. In either case (whether you have access to the front panel or not), you must begin by completing all the steps described in [Powering Down the DC-Input Power Supply](#). Proceed with the next task depending on your setup.

The procedures to disconnect DC-input wires and to remove the module from the chassis have been described in [Disconnect the DC-Input Wires, on page 138](#) and [Remove a DC Power Supply Unit from the Chassis, on page 140](#).

To connect to the DC-input power source, follow the steps described here.

Before you begin



Warning Statement 1073—No User-Serviceable Parts

There are no serviceable parts inside. To avoid risk of electric shock, do not open.

Procedure

Step 1 Locate the circuit breaker on the panel board that services the DC circuit, and switch the circuit breaker to the OFF position.

Step 2 Prepare the DC-input wires and the grounding wire. Crimp the lugs to the cable ends according to the lug manufacturer's direction and your local electrical codes for installation.

Use a heat-shrink sleeve to ensure that there is no exposed wiring extending from the terminal block, when installed.

If you are using cables of different colors for your DC-input wires, we recommend one color for all the positive circuits, a second color for all the negative circuits, and a third color, which is normally solid green or green with yellow stripes, for the safety ground connection.

Step 3 Using a number one Phillips screwdriver, loosen the captive installation screw on the terminal block cover.

Step 4 Using a nut driver, loosen and remove the two nuts in the terminal slot meant for grounding, and set them aside.

The nut driver you are using must have at least a three-inch shaft, to clear the height of the terminal block cover and enable you to loosen or tighten the nuts in the terminal slots.

Warning Statement 1046—Installing or Replacing the Unit

To reduce risk of electric shock, when installing or replacing the unit, the ground connection must always be made first and disconnected last.

If your unit has modules, secure them with the provided screws.

Figure 43: Remove the Nuts for Grounding

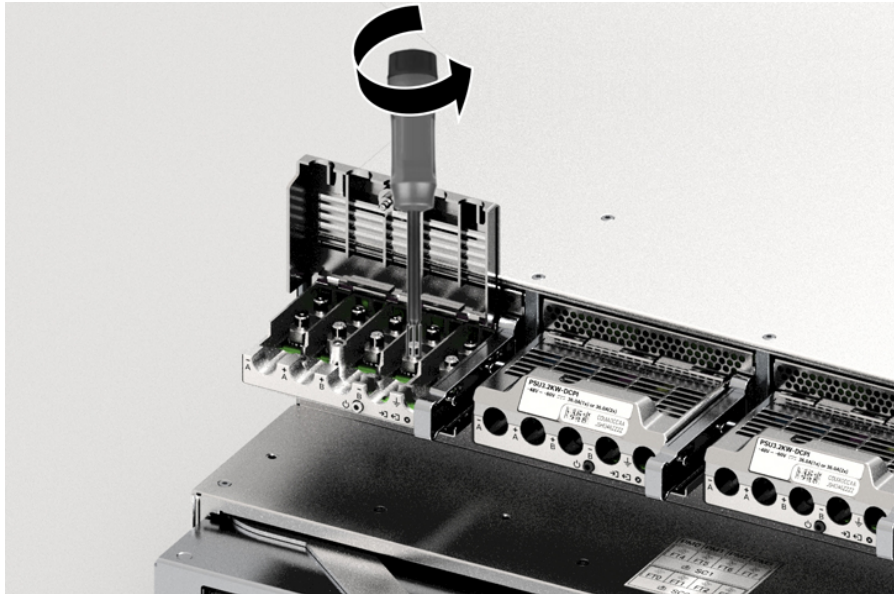

Step 5 Attach the lug to the two posts, secure with the two nuts, and tighten with the torque driver. The fastening torque is between 2.0 and 2.8 Nm. Do not overtorque.

Note Always use a torque driver when you have to tighten nuts; it prevents you from overtightening them.

Figure 44: Tighten the Nuts

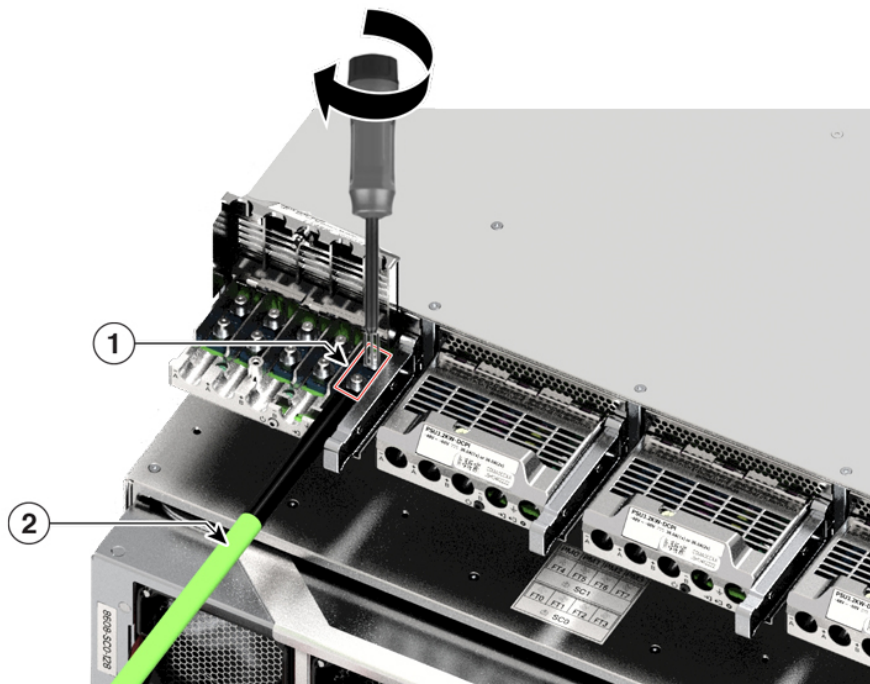

1	Lug secured with the two nuts	2	Grounding wire with heat-shrink sleeve
---	-------------------------------	---	--

Step 6 Attach the four DC-input power source cables similarly.

When facing the terminal block, the circuits are in the following order from left to right: negative (- A), positive (+A), positive (+ B), and negative (-B).

-A and +A form one DC input, and + B and -B form another. Each DC input can be powered either from separate sources, or a suitable single source.

Figure 45: Attach DC-input Power Source Cables

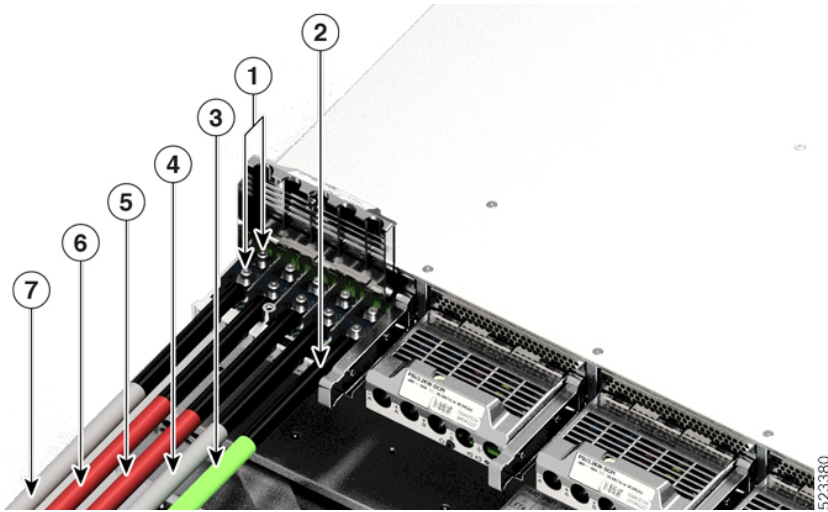

1	Lug secured with two nuts	5	DC-input wire for positive circuit (+ B)
2	Heat-shrink sleeve on all the wires	6	DC-input wire for positive circuit (+A)
3	Grounding wire	7	DC-input wire for negative circuit (- A)
4	DC-input wire for negative circuit (-B)	-	-

Step 7 Close the terminal block cover and finger-tighten the captive installation screw (approximately 0.25 Nm).

Figure 46: Close Terminal Block Cover



Power Up a DC Power Supply Unit

After you have installed the Power Supply Unit (PSU) in the chassis and connected the DC-input wires, follow the steps described here to power up the module and verify that the module is installed correctly.

Before you begin



Warning Statement 1073—No User-Serviceable Parts

There are no serviceable parts inside. To avoid risk of electric shock, do not open.

Procedure

- Step 1** For the powered down circuits connected to the PSUs, turn on the power at the circuit breaker.
- The FAIL LED is illuminated for two to three seconds after DC input is applied through a circuit breaker.
- Step 2** Check that the INPUT and OUTPUT LEDs on the PSU are green.
- Note** DC-input PSUs are shipped with the power button in the default auto-on mode, which means that the unit automatically starts on application of DC-input power. When you install a new or replacement unit straight out of the box, you do not have to press the power button.
- Step 3** Verify the polarity by measuring the voltage between the DC cable leads.
- When measuring, check that the positive (+) lead and the negative (–) lead match the + and – labels on the DC-input PSU's terminal block.

If the DC inputs are powered from separate sources, also check that you have wired the cables straight across to their respective A source and B source, and respective negative and positive terminals. Crossed positive or negative cables constitute a severe safety hazard.

Power Supply Power Cord Specifications

3.2KW Power Supply Unit AC Power Cords

The following table lists the specifications for the AC power cords that are available for the 3.2KW AC-input power supply. The table also includes references to power cord illustrations.



Note All 3.2KW power supply power cord:







- Lengths range from 9.84 – 14 feet (3.0 – 4.293 meters); with most cord lengths between 13 and 14 feet (4.013 and 4.293 meters)
- Have an IEC60320/C19 appliance connector at one end.

Figure 47: IEC60320/C19 Appliance Connector

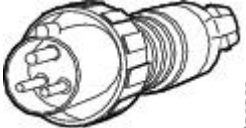
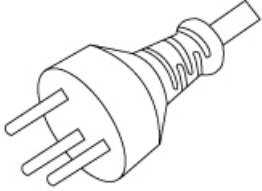

Table 10: 3200 W Power Supply AC Power Cords

Locale	Part Number	Cordset Rating	AC Source Plug Type
Argentina	CAB-I309-C19-INTL	20 A, 250 VAC	<p><i>Figure 48: CAB-I309-C19-INTL= (Argentina)</i></p>
Australia	CAB-AC-16A-AUS	16 A, 250 VAC	<p><i>Figure 49: CAB-AC-16A-AUS= (Australia)</i></p>
China	CAB-9K16A-CH	16 A, 250 VAC	<p><i>Figure 50: CAB-9K16A-CH= (China)</i></p>

Locale	Part Number	Cordset Rating	AC Source Plug Type
Europe	CAB-CEE77-C19-EU	16 A, 250 VAC	Figure 51: CAB-CEE77-C19-EU= and CAB-I309-C19-INTL= (Europe) 
	CAB-I309-C19-INTL	20 A, 250 VAC	
India	CAB-SABS-C19-IND	16 A, 250 VAC	Figure 52: CAB-SABS-C19-IND= (India) 
International	CAB-I309-C19-INTL	20 A, 250 VAC	Figure 53: CAB-I309-C19-INTL= (International) 
Israel	CAB-S132-C19-ISRL	16 A, 250 VAC	Figure 54: CAB-S132-C19-ISRL= (Israel) 
Italy	CAB-C2316-C19-IT	16 A, 250 VAC	Figure 55: CAB-C2316-C19-IT= (Italy) 
Japan, North America (Nonlocking Plug) 200 to 240 VAC Operation	CAB-US620P-C19-US	20 A, 250 VAC	Figure 56: CAB-US620P-C19-US= (Japan, North America - Nonlocking) 
Japan, North America (Locking Plug) 200 to 240 VAC Operation	CAB-L620P-C19-US	20 A, 250 VAC	Figure 57: CAB-L620P-C19-US= (Japan, North America - Locking) 

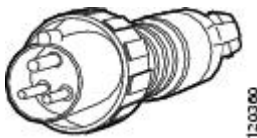
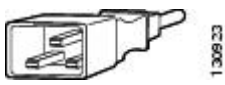
Locale	Part Number	Cordset Rating	AC Source Plug Type
North America	CAB-US520-C19-US	20 A, 125 VAC	Figure 58: CAB-US520-C19-US= (North America) 
South Africa	CAB-I309-C19-INTL	20 A, 250 VAC	Figure 59: CAB-I309-C19-INTL= (South Africa) 
UPS 220V	CAB-C19-CBN	20 A, 250 VAC	Figure 60: 130923 

4.3KW Power Supply Power Cord Specifications



Note Always use the Saf-D-Grid connector toward the router.

Table 11: 30A HVAC/HVDC Cables for PSU4.3KW-HVPI PSU

Locale	Part Number	Cisco Part Number (CPN)	Power Cord Set Rating	Connector Part Number	Power Cord Illustration
AUSTRALIA/NEW ZEALAND	CAB-AC-32A-ANZ	37-101007-01	32A, 250VAC	Saf-D-Grid 3-5958P4 to Hubbell C332P6S Plug	Refer the figure in 30A HVAC/HVDC Cable Illustrations
SWITZERLAND	CAB-AC-32A-CHE	37-101007-01	32A, 250VAC	Saf-D-Grid 3-5958P4 to Hubbell C332P6S Plug	Refer the figure in 30A HVAC/HVDC Cable Illustrations
ITALY	CAB-AC-32A-ITA	37-101007-01	32A, 250VAC	Saf-D-Grid 3-5958P4 to Hubbell C332P6S Plug	Refer the figure in 30A HVAC/HVDC Cable Illustrations
SOUTH AFRICA	CAB-AC-32A-ZAF	37-101007-01	32A, 250VAC	Saf-D-Grid 3-5958P4 to Hubbell C332P6S Plug	Refer the figure in 30A HVAC/HVDC Cable Illustrations
BRAZIL	CAB-AC-32A-BRZ	37-101007-01	32A, 250VAC	Saf-D-Grid 3-5958P4 to Hubbell C332P6S Plug	Refer the figure in 30A HVAC/HVDC Cable Illustrations

4.3KW Power Supply Power Cord Specifications

Locale	Part Number	Cisco Part Number (CPN)	Power Cord Set Rating	Connector Part Number	Power Cord Illustration
ISRAEL	CAB-AC-32A-ISR	37-101007-01	32A, 250VAC	Saf-D-Grid 3-5958P4 to Hubbell C332P6S Plug	Refer the figure in 30A HVAC/HVDC Cable Illustrations
ARGENTINA	CAB-AC-32A-ARG	37-101007-01	32A, 250VAC	Saf-D-Grid 3-5958P4 to Hubbell C332P6S Plug	Refer the figure in 30A HVAC/HVDC Cable Illustrations
INDIA	CAB-AC-32A-IND	37-101007-01	32A, 250VAC	Saf-D-Grid 3-5958P4 to Hubbell C332P6S Plug	Refer the figure in 30A HVAC/HVDC Cable Illustrations
NORTH AMERICA	CAB-AC-30A-US1	37-101008-01	30A, 250VAC	Saf-D-Grid 3-5958P4 to VOLEX 174606	Refer the figure in 30A HVAC/HVDC Cable Illustrations
NORTH AMERICA	CAB-AC-30A-US2	37-101009-01	30A, 250VAC	Saf-D-Grid 3-5958P4 to VOLEX 174606	Refer the figure in 30A HVAC/HVDC Cable Illustrations
NORTH AMERICA	CAB-DC-30A-US1	37-101014-01	30A, 400VDC	Saf-D-Grid 3-5958P4 to Saf-D-Grid 3-5958P4	Refer the figure in 30A HVAC/HVDC Cable Illustrations
NORTH AMERICA	CAB-DC-30A-US2	37-101016-01	30A, 400VDC	Saf-D-Grid 3-5958P4 to Saf-D-Grid 3-5958P4	Refer the figure in 30A HVAC/HVDC Cable Illustrations
NORTH AMERICA	CAB-AC-30A-US3	37-101013-01	30A, 277VAC	Saf-D-Grid 3-5958P4 to HBL2631	Refer the figure in 30A HVAC/HVDC Cable Illustrations
NORTH AMERICA	CAB-AC-30A-US4	37-101018-01	30A, 300VAC	Saf-D-Grid 3-5958P4 to Saf-D-Grid 3-6074P30	Refer the figure in 30A HVAC/HVDC Cable Illustrations
IEC/EU	CAB-AC-32A-EU	37-101019-01	32A, 300VAC	Saf-D-Grid 3-5958P4 to Saf-D-Grid 3-6074P30	Refer the figure in 30A HVAC/HVDC Cable Illustrations
IEC/EU	CAB-DC-32A-EU1	37-101015-01	32A, 400VDC	Saf-D-Grid 3-5958P4 to Saf-D-Grid 3-5958P4	Refer the figure in 30A HVAC/HVDC Cable Illustrations
IEC/EU	CAB-DC-32A-EU2	37-101017-01	32A, 400VDC	Saf-D-Grid 3-5958P4 to Saf-D-Grid 3-5958P4	Refer the figure in 30A HVAC/HVDC Cable Illustrations
CHINA	CAB-AC-32A-CHN	37-101010-01	32A, 250VAC	-	Refer the figure in 30A HVAC/HVDC Cable Illustrations

Locale	Part Number	Cisco Part Number (CPN)	Power Cord Set Rating	Connector Part Number	Power Cord Illustration
KOREA	CAB-AC-32A-KOR	37-101012-01	32A, 250VAC	-	Refer the figure in 30A HVAC/HVDC Cable Illustrations

30A HVAC/HVDC Cable Illustrations

Figure 61: CAB-AC-32A-ANZ, CAB-AC-32A-CHE, CAB-AC-32A-ITA, CAB-AC-32A-BRZ, CAB-AC-32A-ZAF, CAB-AC-32A-ISR, CAB-AC-32A-IND, CAB-AC-32A-ARG Power Cord and Plugs for Standard AC Power Supply

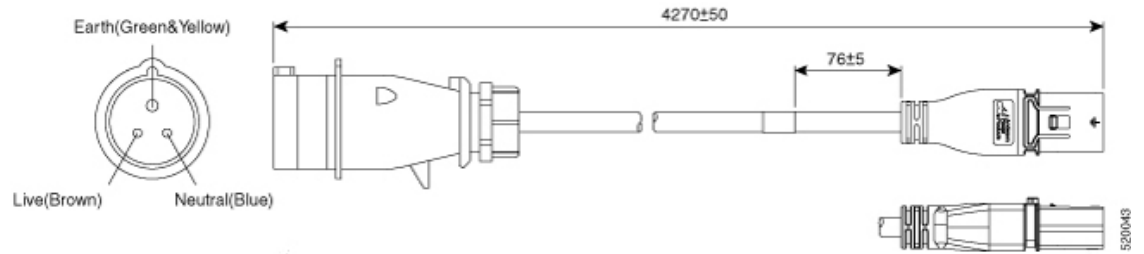

Figure 62: CAB-AC-30A-US1 Power Cord and Plugs for Standard AC Power Supply

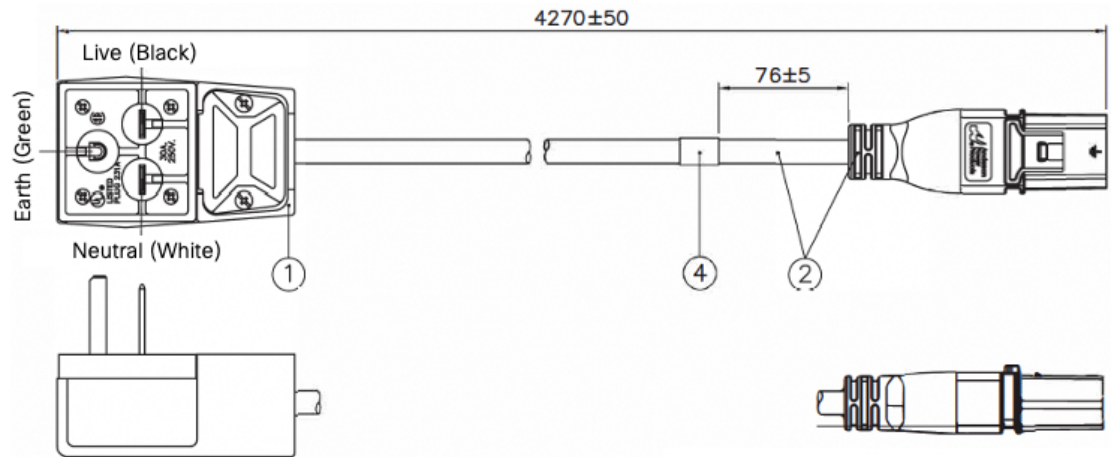

Figure 63: CAB-AC-30A-US2 Power Cord and Plugs for Standard AC Power Supply

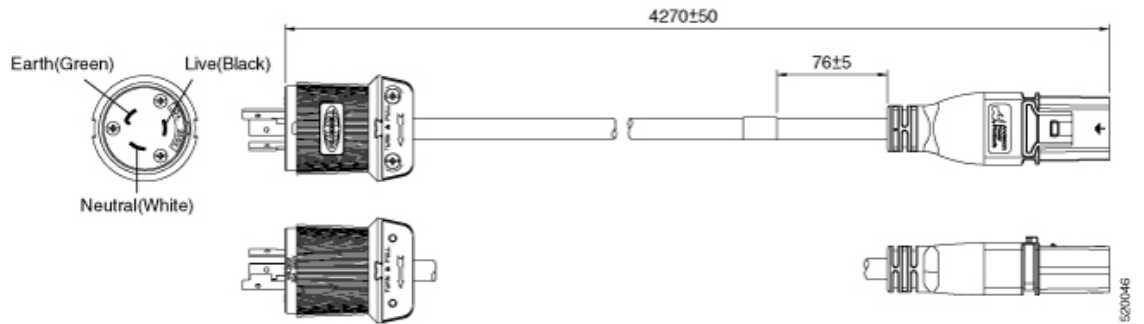

Figure 64: CAB-DC-30A-US1 Power Cord and Plugs for HVDC Power Supply

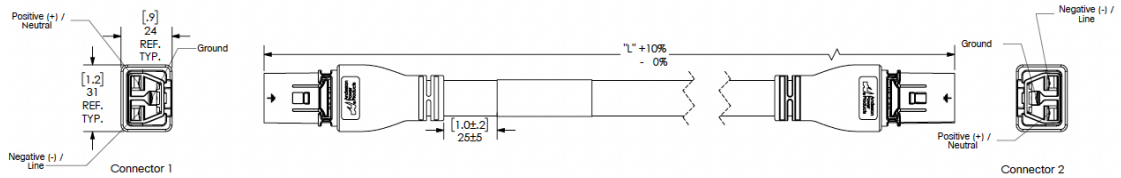

Figure 65: CAB-DC-30A-US2 Power Cord and Plugs for HVDC Power Supply

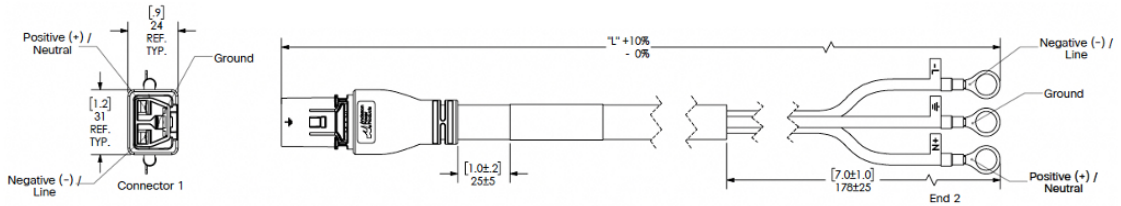

Figure 66: CAB-AC-30A-US3 Power Cord and Plugs for Standard AC Power Supply

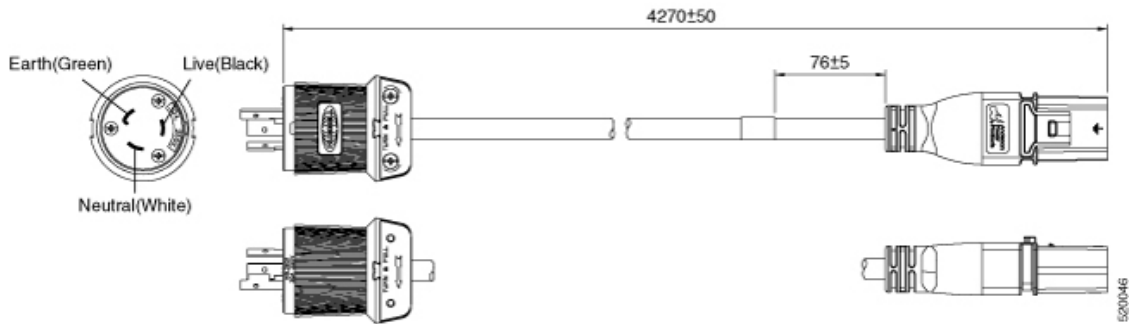

Figure 67: CAB-AC-30A-US4 Power Cord and Plugs for Standard AC Power Supply

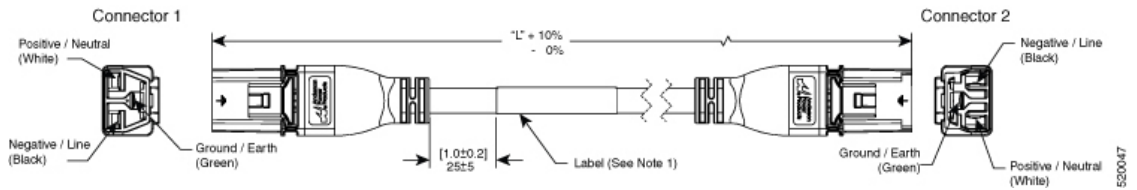

Figure 68: CAB-AC-32A-EU Power Cord and Plugs for Standard AC Power Supply

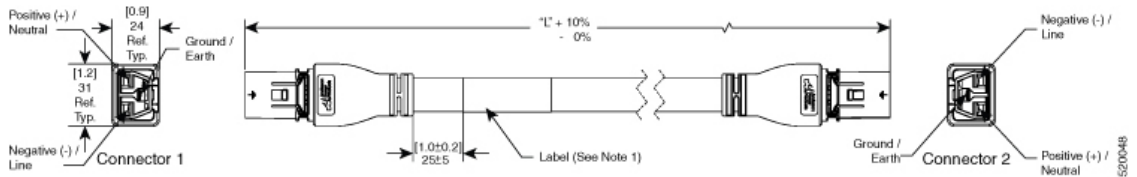

Figure 69: CAB-DC-32A-EU1 Power Cord and Plugs for HVDC Power Supply

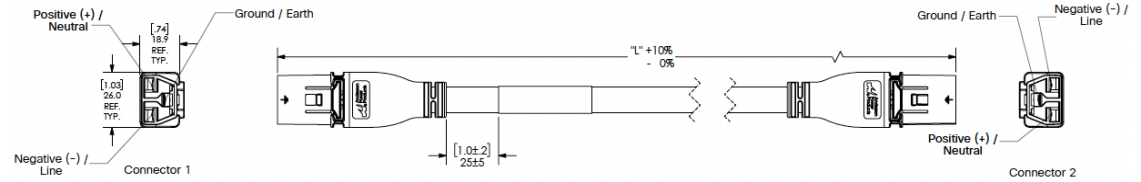

Figure 70: CAB-DC-32A-EU2 Power Cord and Plugs for HVDC Power Supply

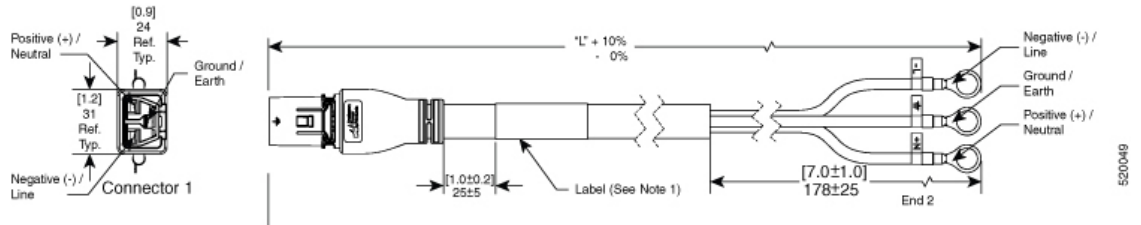

Figure 71: CAB-AC-32A-CHN Power Cord and Plugs for Standard AC Power Supply

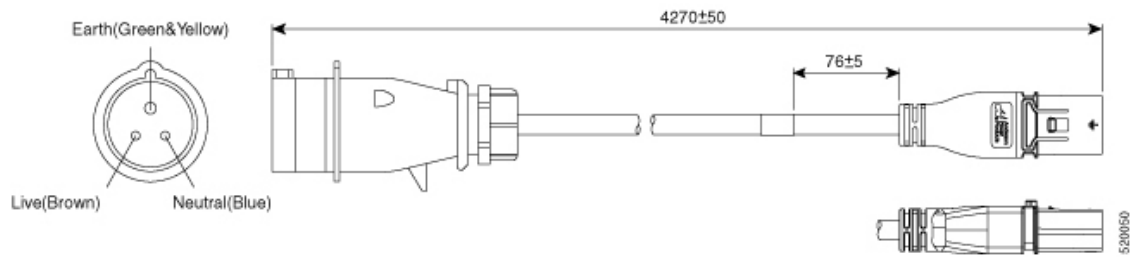

Figure 72: CAB-AC-32A-KOR Power Cord and Plugs for Standard AC Power Supply

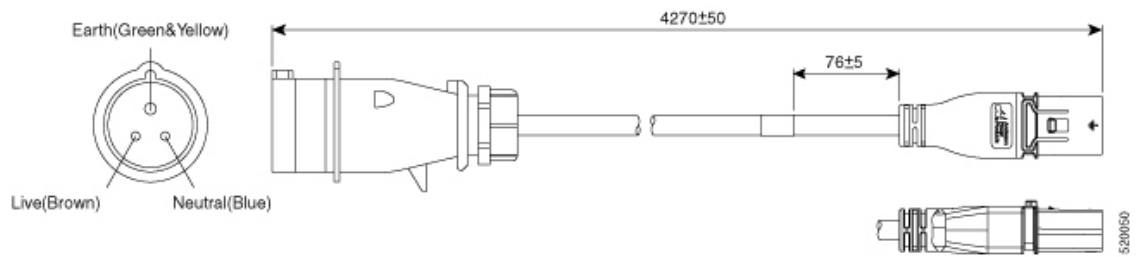

Table 12: 20A HVAC/HVDC Cables for PSU4.3KW-HVPI PSU

Locale	Part Number	Cisco Part Number (CPN)	Length	Power Cord Rating	Connectors	Power Cord Illustration
Argentina	CAB-AC-16A-SG-AR	37-1649-01	14 ft (4.26 m)	16A, 250 VAC	—	Refer the figure in 20A HVAC/HVDC Cables for PSU6.3KW-20A-HV
Australia	CAB-AC-16A-SG-AZ	37-1661-01	14 ft (4.26 m)	16A, 250 VAC	—	Refer the figure in 20A HVAC/HVDC Cables for PSU6.3KW-20A-HV

4.3KW Power Supply Power Cord Specifications

Locale	Part Number	Cisco Part Number (CPN)	Length	Power Cord Rating	Connectors	Power Cord Illustration
Brazil	CAB-AC-16A-SG-BR	37-1650-01	14 ft (4.26 m)	16A, 250 VAC	–	Refer the figure in 20A HVAC/HVDC Cables for PSU6.3KW-20A-HV
China	CAB-AC-16A-SG-CH	37-1655-01	14 ft (4.26 m)	16A, 250 VAC	–	Refer the figure in 20A HVAC/HVDC Cables for PSU6.3KW-20A-HV
China	CAB-AC-16A-CN	37-1655-01	14 ft (4.26 m)	16A, 250 VAC	–	Refer the figure in 20A HVAC/HVDC Cables for PSU6.3KW-20A-HV
Europe	CAB-AC-16A-SG-EU	37-1660-01	14 ft (4.26 m)	16A, 250 VAC	–	Refer the figure in 20A HVAC/HVDC Cables for PSU6.3KW-20A-HV
India	CAB-AC-16A-SG-IND	37-1863-01	14 ft (4.26 m)	16A, 250 VAC	–	Refer the figure in 20A HVAC/HVDC Cables for PSU6.3KW-20A-HV
International/UK	CAB-AC-16A-SG-IN	37-1659-01	14 ft (4.26 m)	16A, 250 VAC	–	Refer the figure in 20A HVAC/HVDC Cables for PSU6.3KW-20A-HV
Israel	CAB-AC-16A-SG-IS	37-1658-01	14 ft (4.26 m)	16A, 250 VAC	–	Refer the figure in 20A HVAC/HVDC Cables for PSU6.3KW-20A-HV
Italy	CAB-AC-16A-SG-IT	37-1651-01	14 ft (4.26 m)	16A, 250 VAC	–	Refer the figure in 20A HVAC/HVDC Cables for PSU6.3KW-20A-HV
Japan	CAB-AC-16A-SG-JPN	37-1656-01	14 ft (4.26 m)	16A, 250 VAC	–	Refer the figure in 20A HVAC/HVDC Cables for PSU6.3KW-20A-HV
South Africa	CAB-AC-16A-SG-SA	37-1647-01	14 ft (4.26 m)	16A, 250 VAC	–	Refer the figure in 20A HVAC/HVDC Cables for PSU6.3KW-20A-HV
Switzerland	CAB-AC-16A-SG-SW	37-1654-01	14 ft (4.26 m)	16A, 250 VAC	–	Refer the figure in 20A HVAC/HVDC Cables for PSU6.3KW-20A-HV
South Korea	CAB-AC-16A-SG-SK	37-1646-01	14 ft (4.26 m)	16A, 250 VAC	–	Refer the figure in 20A HVAC/HVDC Cables for PSU6.3KW-20A-HV

Locale	Part Number	Cisco Part Number (CPN)	Length	Power Cord Rating	Connectors	Power Cord Illustration
UK	CAB-AC-16A-SG-UK	37-1864-01	14 ft (4.26 m)	16A, 250 VAC	–	Refer the figure in 20A HVAC/HVDC Cables for PSU6.3KW-20A-HV
North America (locking) 200-240 VAC operation	CAB-AC-20A-SG-US3	37-1656-01	14 ft (4.26 m)	20A, 250 VAC	Saf-D-Grid to L6-20	Refer the figure in 20A HVAC/HVDC Cables for PSU6.3KW-20A-HV
North America 277 VAC operation	CAB-AC-20A-SG-US4	37-1645-01	14 ft (4.26 m)	20A, 277 VAC	Saf-D-Grid to L7-20	Refer the figure in 20A HVAC/HVDC Cables for PSU6.3KW-20A-HV
North America Cabinet Jumper Power Distribution unit (PDU)	CAB-AC-20A-SG-C20	37-1653-01	14 ft (4.26 m)	20A, 250 VAC	Saf-D-Grid to C20	Refer the figure in 20A HVAC/HVDC Cables for PSU6.3KW-20A-HV
North America, Ring Terminal source plug	CAB-HV-25A-SG-US2	37-1641-01	14 ft (4.26 m)	20A, 300 VAC/500 VDC	Saf-D-Grid to 3 ring terminal	Refer the figure in 20A HVAC/HVDC Cables for PSU6.3KW-20A-HV
International IEC/EU, Ring Terminal source plug	CAB-HV-25A-SG-IN2	37-1640-01	14 ft (4.26 m)	20A, 300 VAC/500 VDC	Saf-D-Grid to 3 ring terminal	Refer the figure in 20A HVAC/HVDC Cables for PSU6.3KW-20A-HV
US, IEC/EU, CANADA, MEXICO, BRAZIL, NETHERLANDS, IRELAND, FRANCE, UK, GERMANY, SWITZERLAND, NORWAY, SPAIN, ITALY, SINGAPORE, CHINA	CAB-AC-20A-NA	37-2126-01	6.6 ft (2m)	20A, 250VAC	Saf-D-Grid 3-5958P2 to IEC 60320 C20	Refer the figure in 20A HVAC/HVDC Cables for PSU6.3KW-20A-HV

20A HVAC/HVDC Cable Illustrations

Figure 73: CAB-AC-16A-SG-AR Power Cord

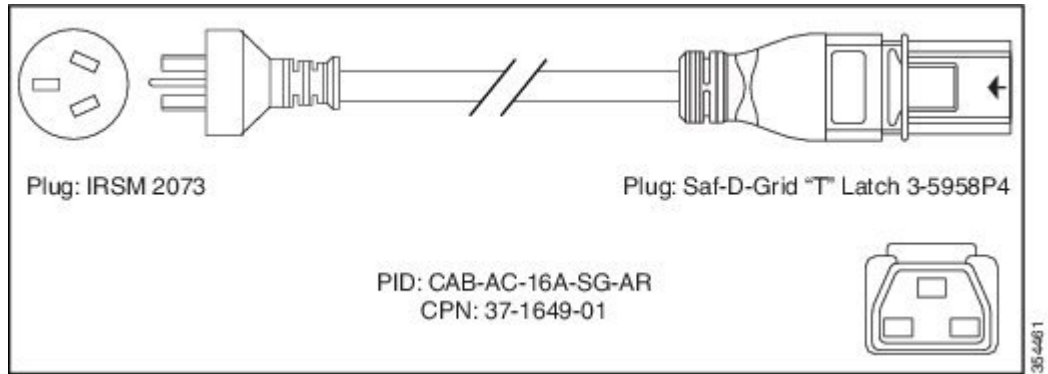

Figure 74: CAB-AC-16A-SG-AZ Power Cord

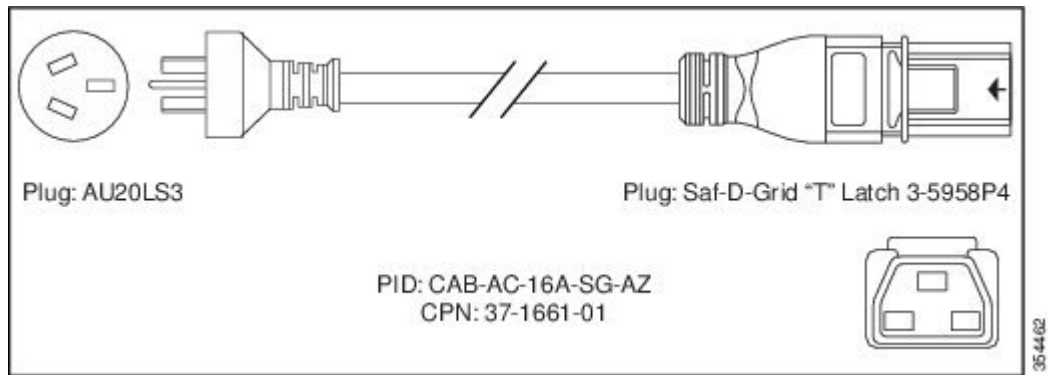

Figure 75: CAB-AC-16A-SG-BR Power Cord

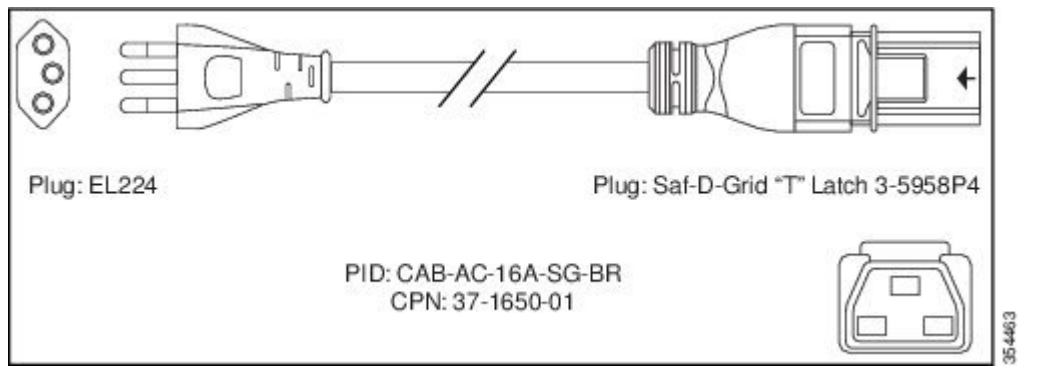

Figure 76: CAB-AC-16A-SG-CH Power Cord

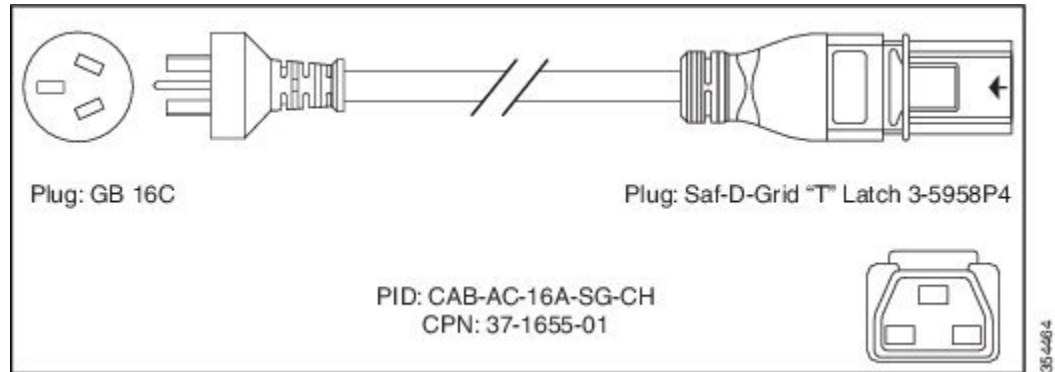

Figure 77: CAB-AC-16A-SG-EU Power Cord

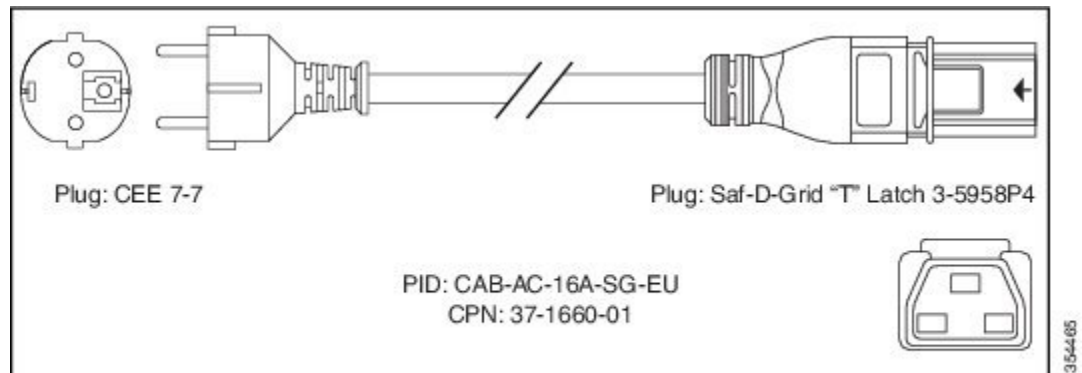

Figure 78: CAB-AC-16A-SG-IND Power Cord

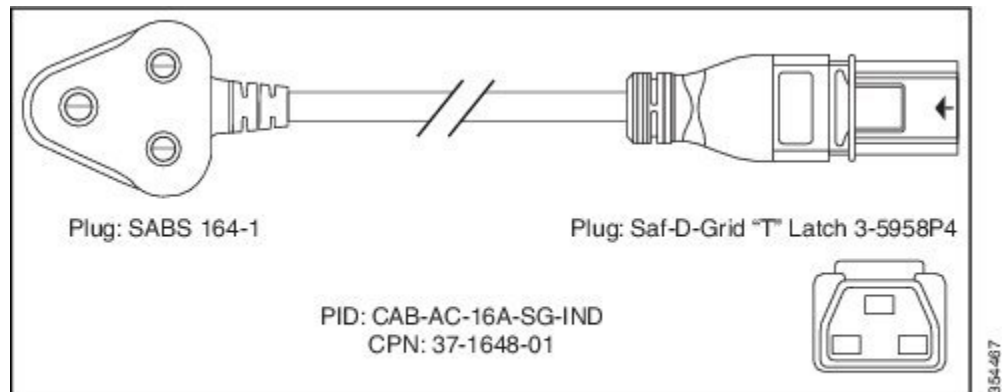

Figure 79: CAB-AC-16A-SG-IN Power Cord

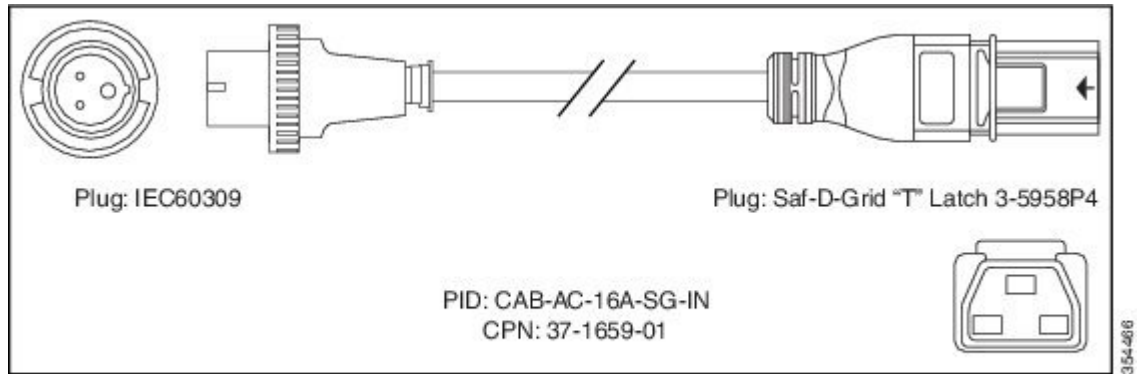

Figure 80: CAB-AC-16A-SG-IS Power Cord

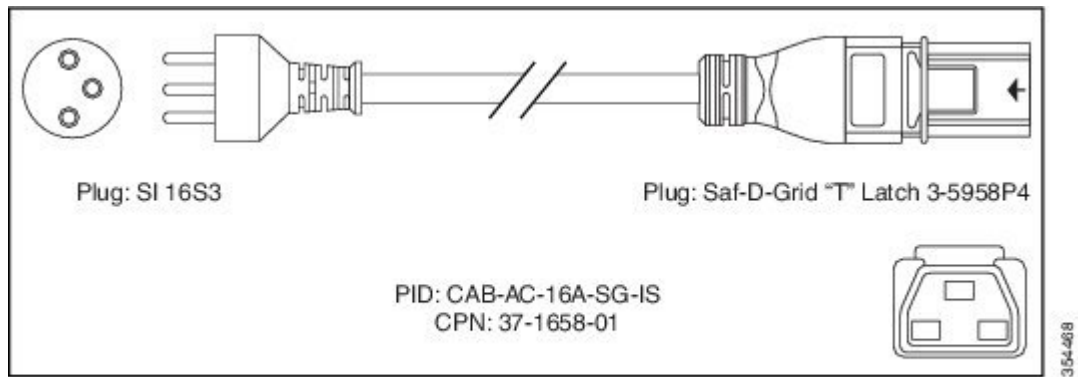

Figure 81: CAB-AC-16A-SG-IT Power Cord

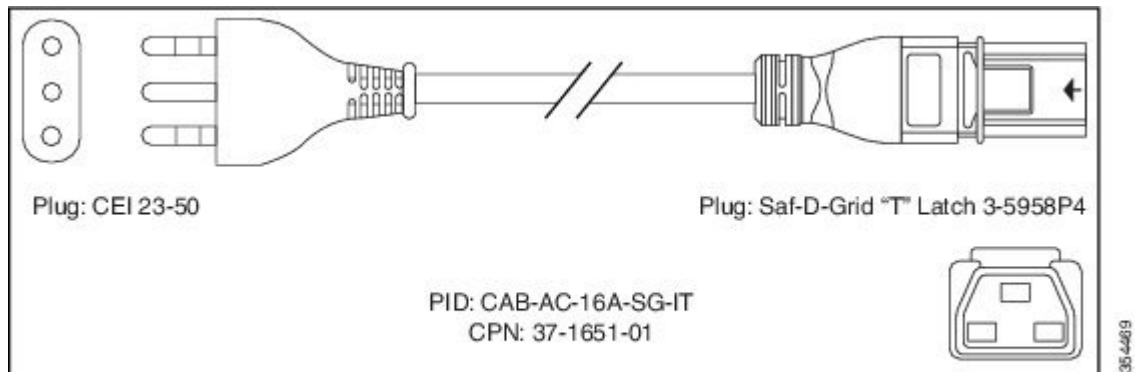

Figure 82: CAB-AC-16A-SG-JPN Power Cord

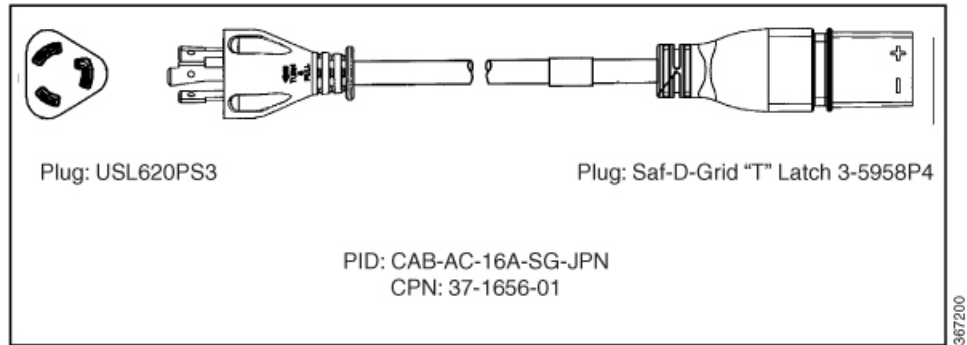

Figure 83: CAB-AC-16A-SG-SA Power Cord

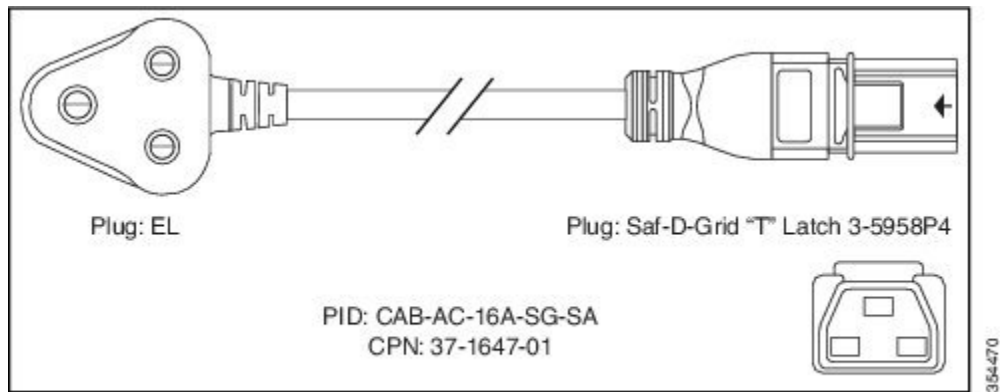

Figure 84: CAB-AC-16A-SG-SW Power Cord

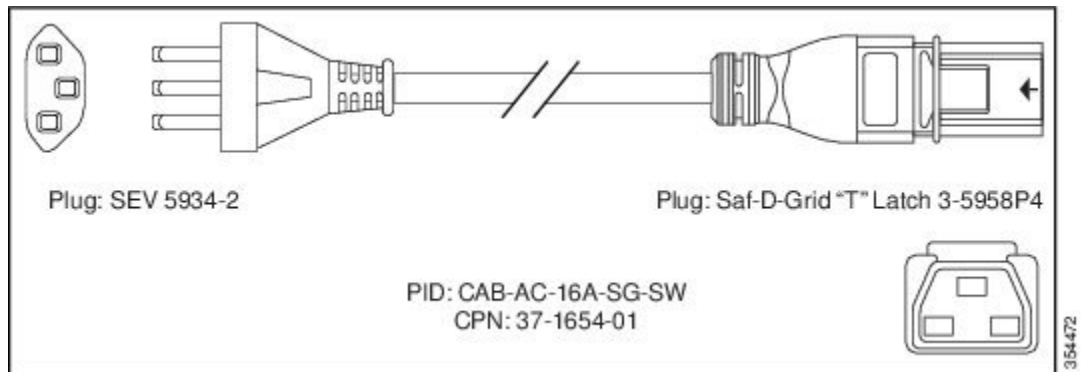

Figure 85: CAB-AC-16A-SG-UK Power Cord

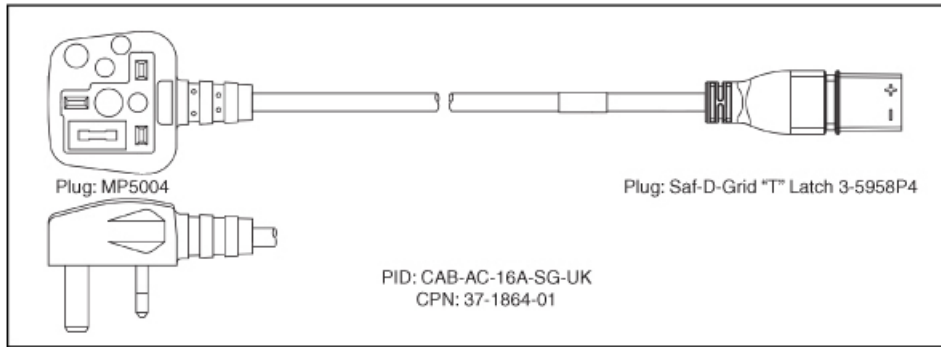

Figure 86: CAB-AC-20A-SG-US Power Cord

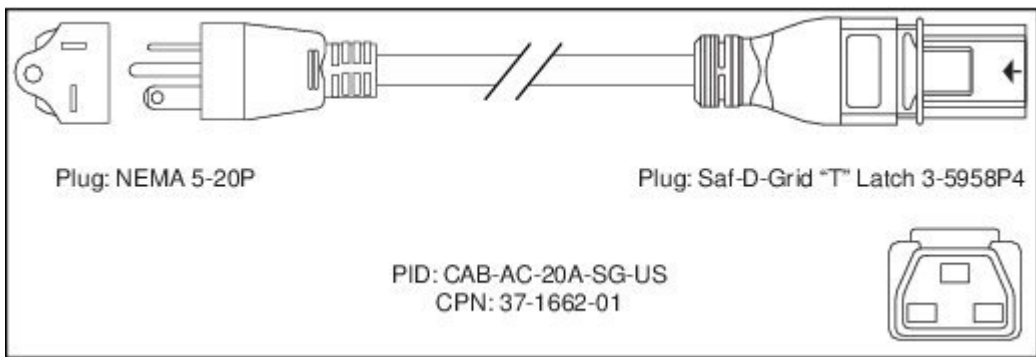

Figure 87: CAB-AC-20A-SG-US1 Power Cord

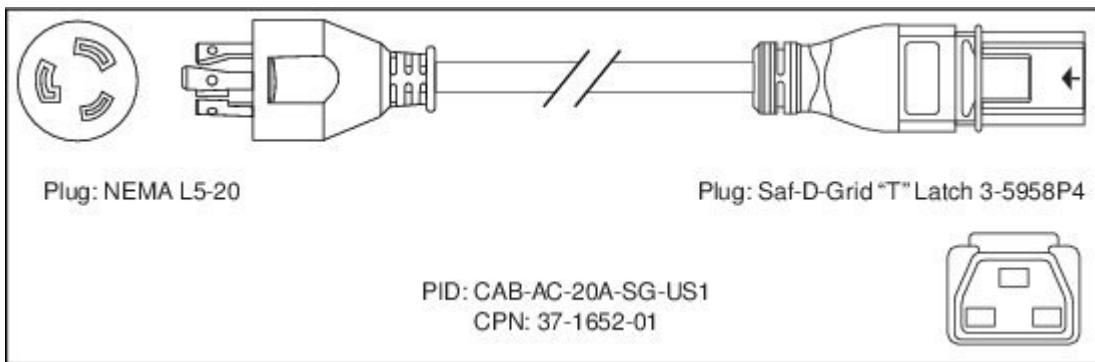

Figure 88: CAB-AC-20A-SG-US2 Power Cord

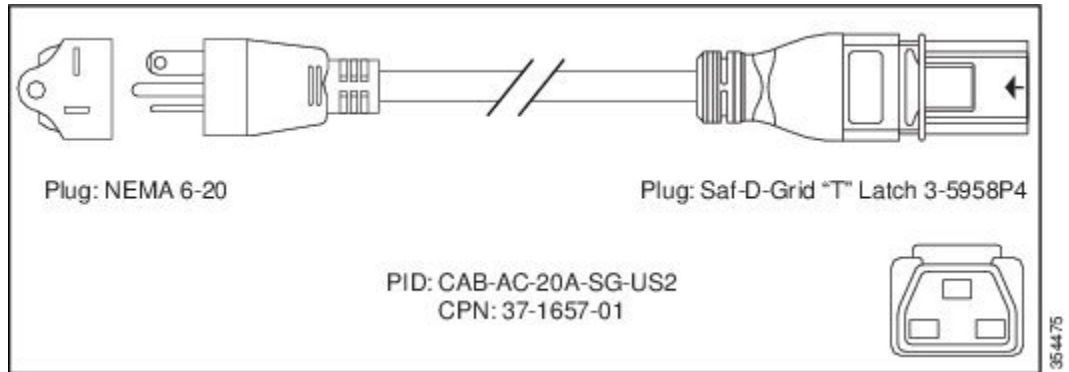

Figure 89: CAB-AC-20A-SG-US3 Power Cord

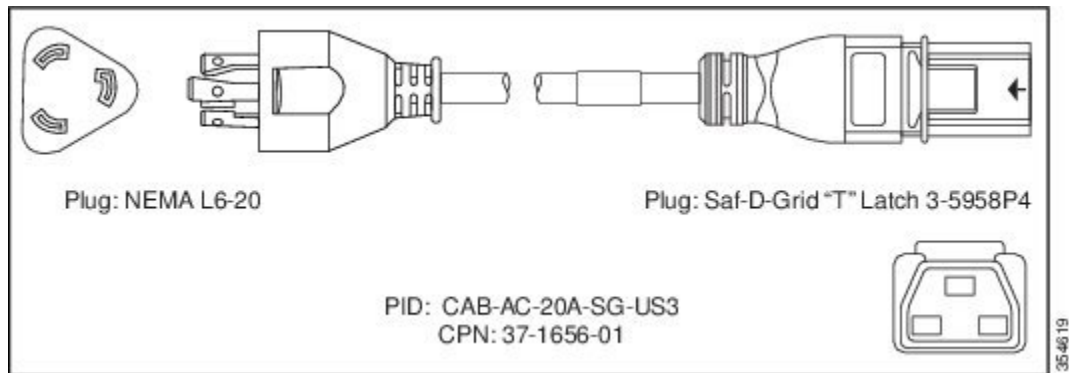

Figure 90: CAB-AC-20A-SG-US4 Power Cord

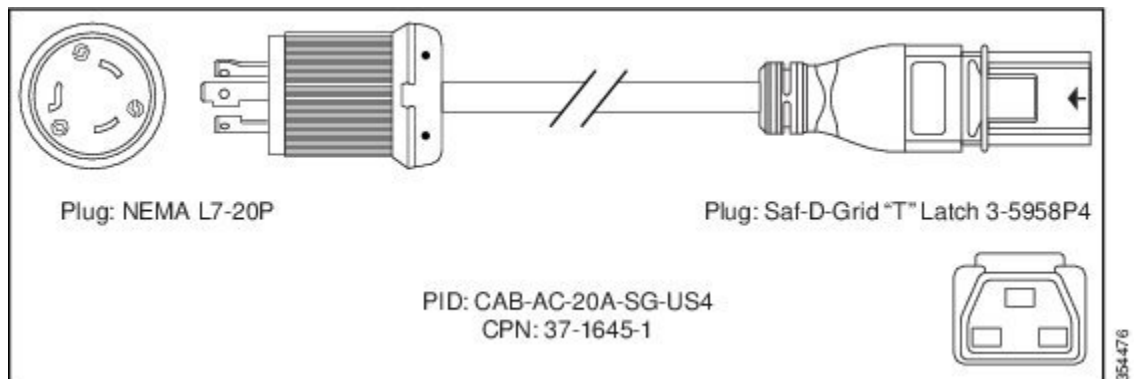

Figure 91: CAB-AC-20A-SG-C20 Power Cord

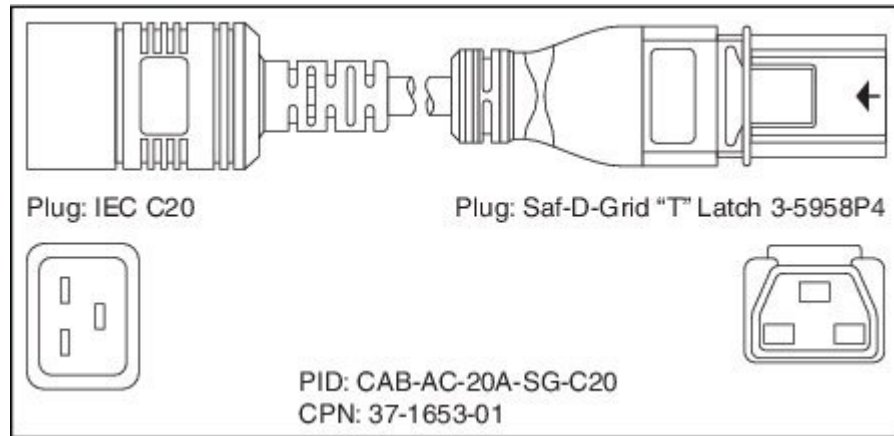

Figure 92: CAB-HV-25A-SG-US2 Power Cord

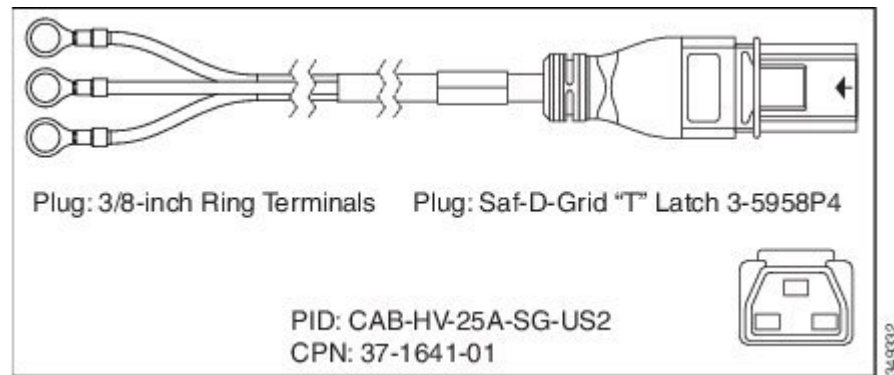

Figure 93: CAB-HV-25A-SG-IN2 Power Cord

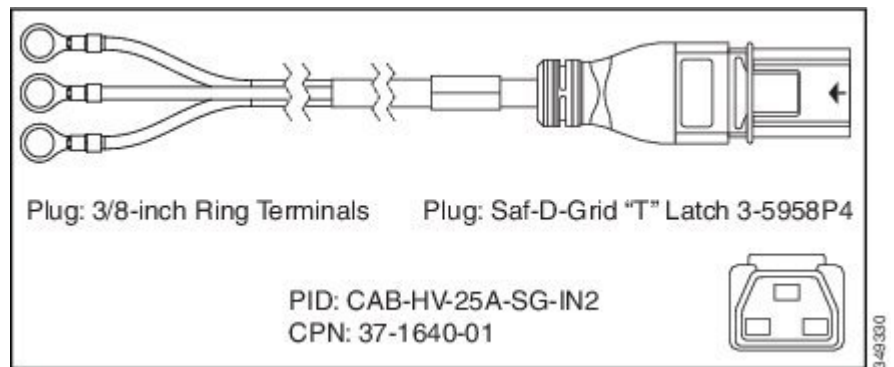

Figure 94: CAB-HV-25A-SG-IN3 Power Cord

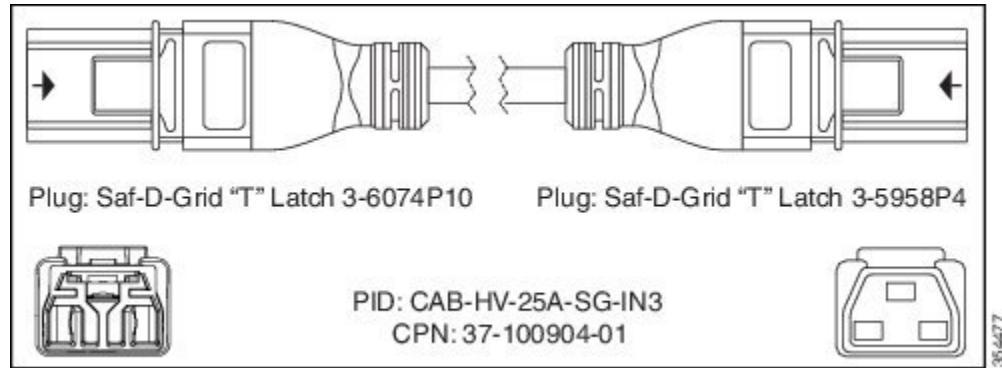
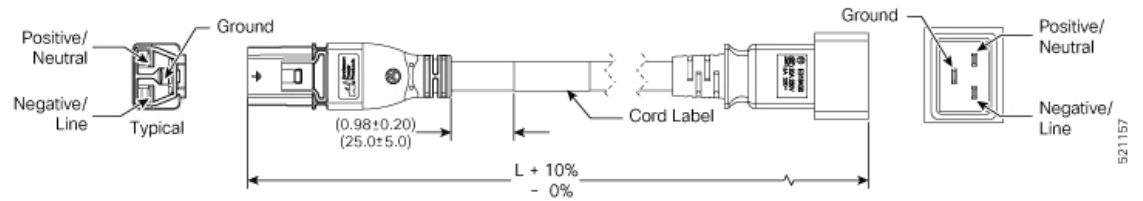

Figure 95: CAB-AC-20A-NA Power Cord





CHAPTER 5

Connect Router to the Network



Note The images in this chapter are only for representation purposes, unless specified otherwise. The chassis' actual appearance and size may vary.

- [Connecting a Console to the Router, on page 85](#)
- [Connect the Management Interface, on page 86](#)
- [Transceivers, Connectors, and Cables, on page 87](#)
- [Install and Remove SFP or SFP+ Modules, on page 88](#)
- [Install and Remove QSFP Transceiver Modules, on page 93](#)
- [Connect Interface Ports, on page 100](#)
- [Maintain Transceivers and Optical Cables, on page 100](#)
- [Create the Initial Router Configuration, on page 100](#)

Connecting a Console to the Router

Before you create a network management connection for the router or connect the router to the network, you must create a local management connection through a console terminal and configure an IP address for the router. The router can be accessed using remote management protocols, such as SSH and Telnet. By default, SSH is included in the software image. But telnet is not part of the software image. You must manually install the telnet optional package to use it.

You also can use the console to perform the following functions, each of which can be performed through the management interface after you make that connection:

- configure the router using the command-line interface (CLI)
- monitor network statistics and errors
- configure Simple Network Management Protocol (SNMP) agent parameters
- initiate software download updates via console

You make this local management connection between the asynchronous serial port on a Route Processor card and a console device capable of asynchronous transmission. Typically, you can use a computer terminal as the console device. On the Route Processor cards, you use the console serial port.



Note Before you can connect the console port to a computer terminal, ensure that the computer terminal supports VT100 terminal emulation. The terminal emulation software makes communication between the router and computer possible during setup and configuration.

Before you begin

- The router must be fully installed in its rack. The router must be connected to a power source and grounded.
- The necessary cabling for the console, management, and network connections must be available.
 - An RJ45 rollover cable and a DB9F/RJ45 adapter.
 - Network cabling should already be routed to the location of the installed router.

Procedure

Step 1 Configure the console device to match the following default port characteristics:

- 115200 baud
- 8 data bits
- 1 stop bit
- No parity

Step 2 Connect an RJ45 rollover cable to a terminal, PC terminal emulator, or terminal server.
The RJ45 rollover cable is not part of the accessory kit.

Step 3 Route the RJ45 rollover cable as appropriate and connect the cable to the console port on the chassis.
If the console or modem cannot use an RJ45 connection, use the DB9F/RJ45F PC terminal adapter. Alternatively, you can use an RJ45/DSUB F/F or RJ45/DSUB R/P adapter, but you must provide those adapters.

What to do next

You are ready to create the initial router configuration.

Connect the Management Interface

The Route Processor management port (MGMT ETH) provides out-of-band management, which lets you to use the command-line interface (CLI) to manage the router by its IP address. This port uses a 10/100/1000 Ethernet connection with an RJ-45 interface.



Note In a dual Route Processor router, you can ensure that the active Route Processor card is always connected to the network by connecting the management interface on both Route Processor cards to the network. That is, you can perform this task for each Route Processor card. When the Route Processor card is active, the router automatically has a management interface that is running and accessible from the network.



Caution To prevent an IP address conflict, do not connect the MGMT 100/1000 Ethernet port until the initial configuration is complete.

Before you begin

You must have completed the initial router configuration.

Procedure

- Step 1** Connect a modular, RJ-45, UTP cable to the MGMT ETH port on the Route Processor card.
- Step 2** Route the cable through the central slot in the cable management system.
- Step 3** Connect the other end of the cable to a 100/1000 Ethernet port on a network device.

What to do next

You are ready to connect the interface ports to the network.

Transceivers, Connectors, and Cables

Transceiver and Cable Specifications

To determine which transceivers and cables are supported by this router, see [Cisco Transceiver Modules Compatibility Information](#).

To see the transceiver specifications and installation information, see [Cisco Transceiver Modules Install and Upgrade Guides](#).

RJ-45 Connectors

The RJ-45 connector connects Category 3, Category 5, Category 5e, Category 6, or Category 6A foil twisted-pair or unshielded twisted-pair cable from the external network to the following module interface connectors:

- Router chassis
 - CONSOLE port
 - MGMT ETH port



Caution To comply with GR-1089 intrabuilding, lightning immunity requirements, you must use a foil twisted-pair (FTP) cable that is properly grounded at both ends.

The following figure shows the RJ-45 connector.

Figure 96: RJ-45 Connector

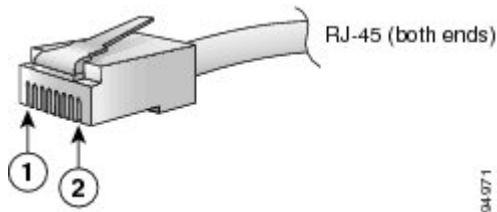

1	Pin 1	2	Pin 8
---	-------	---	-------

Install and Remove SFP or SFP+ Modules

Before you remove or install an SFP or SFP+ module, read the installation information in this section.



Warning **Statement 1051—Laser Radiation**

Invisible laser radiation may be emitted from disconnected fibers or connectors. Do not stare into beams or view directly with optical instruments.



Caution Protect the line card by inserting a clean SFP/SFP+ module cage cover, which is shown in the figure below, into the optical module cage when there is no SFP or SFP+ module installed.

Figure 97: SFP/SFP+ Module Cage Cover

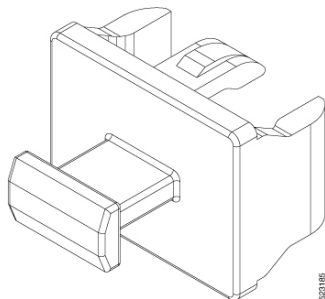



Caution Protect the SFP or SFP+ modules by inserting clean dust covers into them after the cables are removed. Be sure to clean the optic surfaces of the fiber cables before you plug them back into the optical ports of another module. Avoid getting dust and other contaminants into the optical ports of your SFP or SFP+ modules, because the optics do not work correctly when obstructed by dust.



Caution We strongly recommended that you do not install or remove the SFP or SFP+ module with fiber-optic cables that are attached to it because of the potential of damaging the cable, the cable connector, or the optical interfaces in the module. Disconnect all cables before removing or installing an SFP or SFP+ module. Removing and inserting a module can shorten its useful life, so you should not remove and insert modules any more than is absolutely necessary.



Note When installing an SFP or SFP+ module, you should hear a click as the triangular pin on the bottom of the module snaps into the hole in the receptacle. The click indicates that the module is correctly seated and secured in the receptacle. Verify that the modules are seated and secured in their assigned receptacles on the line card by firmly pushing on each SFP or SFP+ module.

Bale Clasp SFP or SFP+ Module

The bale clasp SFP or SFP+ module has a clasp that you use to remove or install the module (see the figure below).

Figure 98: Bale Clasp SFP or SFP+ Module

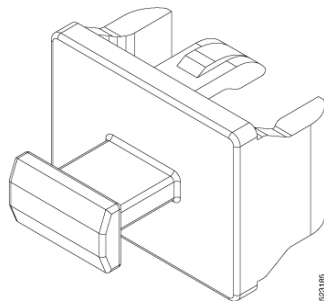

Installing the Transceiver Module



Warning **Statement 1055**—Class 1/1M Laser

Invisible laser radiation is present. Do not expose to users of telescopic optics. This applies to Class 1/1M laser products.



Warning **Statement 1051**—Laser Radiation

Invisible laser radiation may be emitted from disconnected fibers or connectors. Do not stare into beams or view directly with optical instruments.



Warning **Statement 1079**—Hot Surface

This icon is a hot surface warning. To avoid personal injury, do not touch without proper protection.



Caution The transceiver module is a static-sensitive device. Always use an ESD wrist strap or similar individual grounding device when handling transceiver modules or coming into contact with system modules.



Caution Protect the transceiver ports by inserting clean dust caps (8000-QSFP-DCAP) into any ports not in use. Be sure to clean the optic surfaces of the fiber cables before you plug them back into the optical ports of another module. Use dust caps for all the open ports on the chassis.

The router ships with dust caps plugged in. We highly recommend you to keep the dust caps plugged in until you are ready to plug an optic.

The dust caps protect the ports from possible EMI interference and also avoid contamination due to dust collection. To meet the EMI interference requirements, you must use the metal dust caps when the ports are not in use by optical modules.

The QSFP transceiver module has a pull-tab latch. To install a transceiver module, follow these steps:

Procedure

- Step 1** Attach an ESD wrist strap to yourself and a properly grounded point on the chassis or the rack.
- Step 2** Remove the transceiver module from its protective packaging.
- Step 3** Check the label on the transceiver module body to verify that you have the correct model for your network. Do not remove the dust plug until you're ready to attach the network interface cable. Dust plug is not shown in the images.
- Step 4** Hold the transceiver by the pull-tab so that the identifier label is on the top.
- Step 5** Align the transceiver module in front of the module's transceiver socket opening and carefully slide the transceiver into the socket until the transceiver contact with the socket electrical connector.

Figure 99: Installing the QSFP Transceiver Module

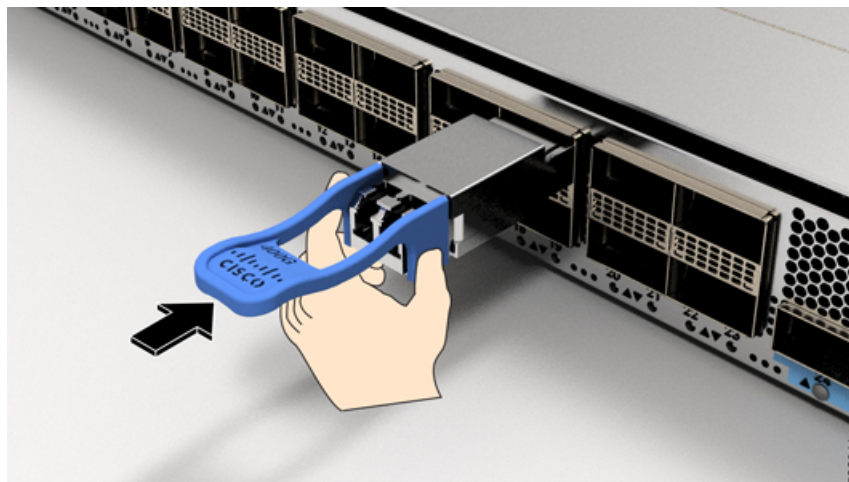

- Step 6** Press firmly on the front of the transceiver module with your thumb to fully seat the transceiver in the module's transceiver socket (see the below figure).

Caution If the latch isn't fully engaged, you might accidentally disconnect the transceiver module.

Figure 100: Seating the QSFP Transceiver Module

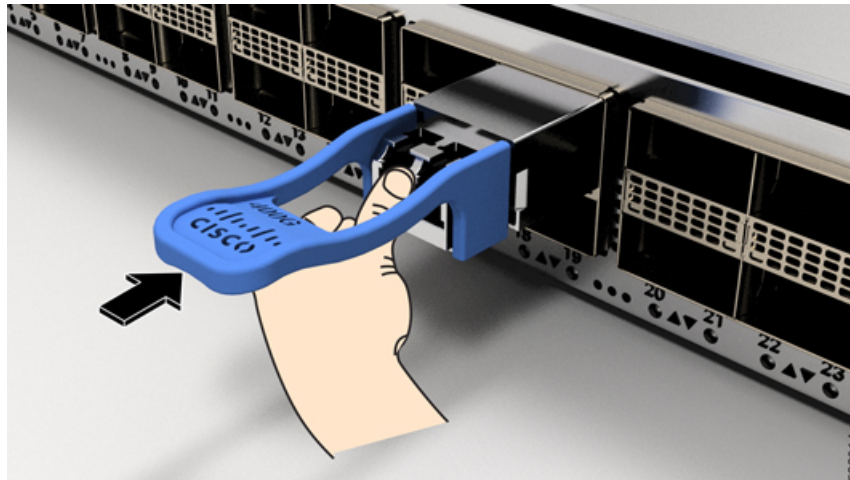

Remove a Bale Clasp SFP or SFP+ Module

To remove this type of SFP or SFP+ module, follow these steps:

Procedure

- Step 1** Attach an ESD-preventive wrist or ankle strap and follow its instructions for use.
- Step 2** Disconnect and remove all interface cables from the ports; note the current connections of the cables to the ports on the line card.
- Step 3** Open the bale clasp on the SFP module with your index finger, as shown in the figure below. If the bale clasp is obstructed and you cannot use your index finger to open it, use a small flat-blade screwdriver or other long, narrow instrument to open the bale clasp.
- Step 4** Grasp the SFP module between your thumb and index finger and carefully remove it from the port, as shown in the figure below.

Note This action must be performed during your first instance. After all the ports are populated, this may not be possible.

Figure 101: Removing a Bale Clasp SFP or SFP+ Module

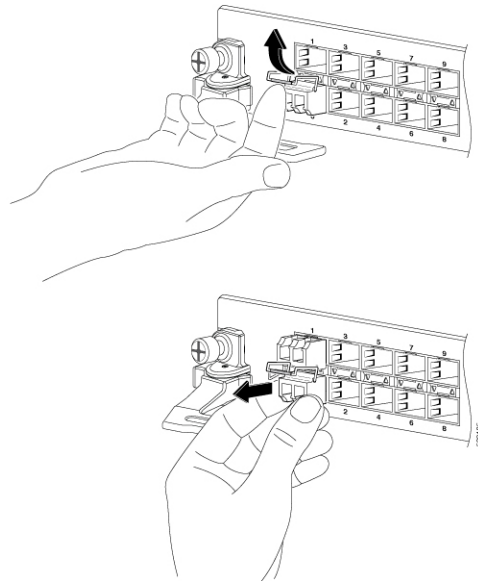

- Step 5** Place the removed SFP module on an antistatic mat, or immediately place it in a static shielding bag if you plan to return it to the factory.
- Step 6** Protect your line card by inserting a clean SFP module cage covers into the optical module cage when there is no SFP module installed.

Install and Remove QSFP Transceiver Modules

This section provides the installation, cabling, and removal instructions for the Quad Small Form-Factor Pluggable transceiver modules. Refer to the [Cisco Optical Transceiver Handling Guide](#) for additional details on optical transceivers.

The following figure shows a 400-Gigabit QSFP-DD optical transceiver.

Figure 102: 400-Gigabit QSFP-DD Transceiver Module

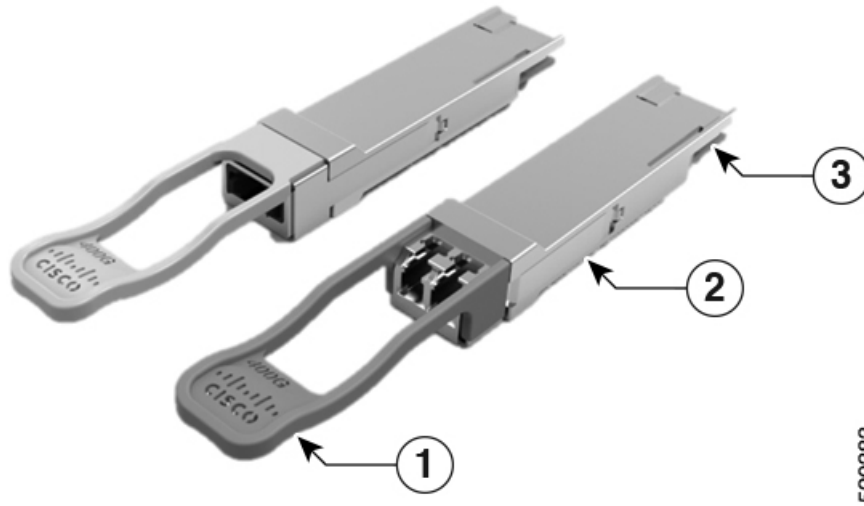

1	Pull-tab	2	QSFP-DD transceiver body
3	Electrical connection to the module circuitry		



Warning Statement 1079—Hot Surface

This icon is a hot surface warning. To avoid personal injury, do not touch without proper protection.



Required Tools and Equipment

You need these tools to install the transceiver modules:

- Wrist strap or other personal grounding device to prevent ESD occurrences.
- Antistatic mat or antistatic foam to set the transceiver on.
- Fiber-optic end-face cleaning tools and inspection equipment.

Installing the Transceiver Module



Warning **Statement 1055**—Class 1/1M Laser

Invisible laser radiation is present. Do not expose to users of telescopic optics. This applies to Class 1/1M laser products.



Warning **Statement 1051**—Laser Radiation

Invisible laser radiation may be emitted from disconnected fibers or connectors. Do not stare into beams or view directly with optical instruments.



Warning **Statement 1079**—Hot Surface

This icon is a hot surface warning. To avoid personal injury, do not touch without proper protection.



Caution The transceiver module is a static-sensitive device. Always use an ESD wrist strap or similar individual grounding device when handling transceiver modules or coming into contact with system modules.

Caution Protect the transceiver ports by inserting clean dust caps (8000-QSFP-DCAP) into any ports not in use. Be sure to clean the optic surfaces of the fiber cables before you plug them back into the optical ports of another module. Use dust caps for all the open ports on the chassis.

The router ships with dust caps plugged in. We highly recommend you to keep the dust caps plugged in until you are ready to plug an optic.

The dust caps protect the ports from possible EMI interference and also avoid contamination due to dust collection. To meet the EMI interference requirements, you must use the metal dust caps when the ports are not in use by optical modules.

The QSFP transceiver module has a pull-tab latch. To install a transceiver module, follow these steps:

Procedure

- Step 1** Attach an ESD wrist strap to yourself and a properly grounded point on the chassis or the rack.
- Step 2** Remove the transceiver module from its protective packaging.
- Step 3** Check the label on the transceiver module body to verify that you have the correct model for your network. Do not remove the dust plug until you're ready to attach the network interface cable. Dust plug is not shown in the images.
- Step 4** Hold the transceiver by the pull-tab so that the identifier label is on the top.
- Step 5** Align the transceiver module in front of the module's transceiver socket opening and carefully slide the transceiver into the socket until the transceiver contact with the socket electrical connector.

Figure 103: Installing the QSFP Transceiver Module

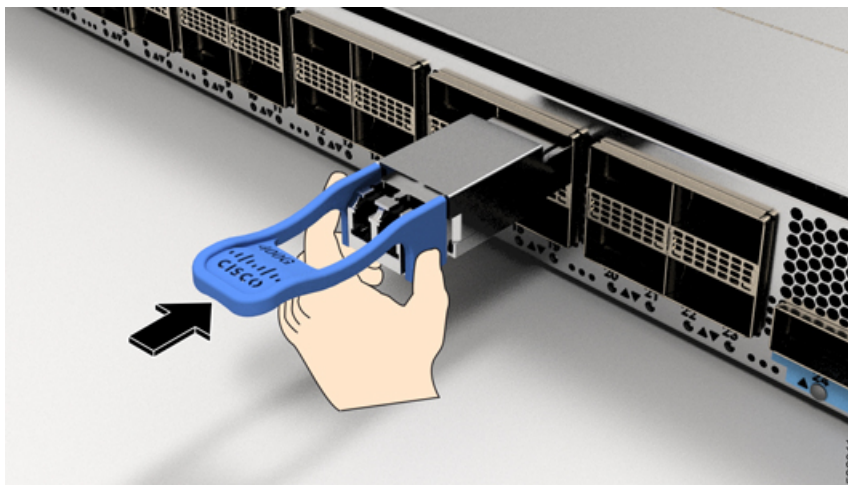

- Step 6** Press firmly on the front of the transceiver module with your thumb to fully seat the transceiver in the module's transceiver socket (see the below figure).

Caution If the latch isn't fully engaged, you might accidentally disconnect the transceiver module.

Figure 104: Seating the QSFP Transceiver Module

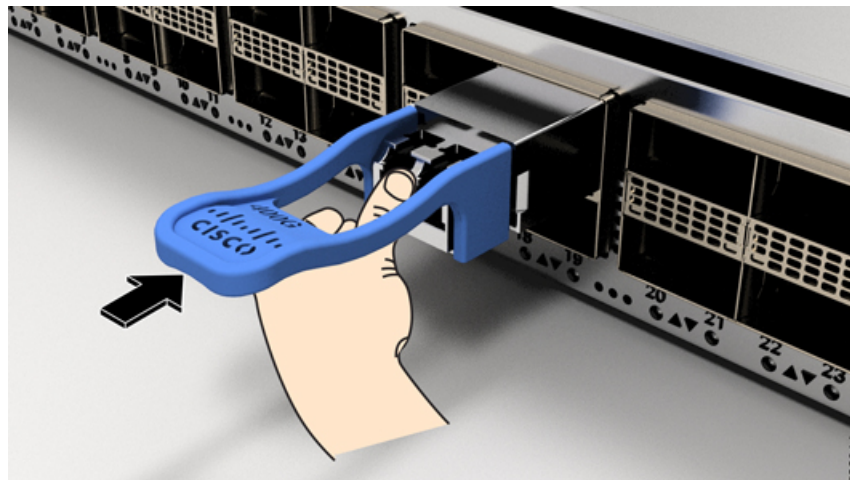

Attach the Optical Network Cable

Before you begin

Before you remove the dust plugs and make any optical connections, follow these guidelines:

- Keep the protective dust plugs installed in the unplugged fiber-optic cable connectors and in the transceiver optical bores until you are ready to make a connection.
- Inspect and clean the optical connector end faces just before you make any connections.
- Grasp the optical connector only by the housing to plug or unplug a fiber-optic cable.



Note The transceiver modules and fiber connectors are keyed to prevent incorrect insertion.



Note The multiple-fiber push-on (MPO) connectors on the optical transceivers support network interface cables with either physical contact (PC) or ultra-physical contact (UPC) flat polished face types. The MPO connectors on the optical transceivers do not support network interface cables with an angle-polished contact (APC) face type.



Note Inspect the MPO connector for the correct cable type, cleanliness, and any damage. For complete information on inspecting and cleaning fiber-optic connections, see the [Inspection and Cleaning Procedures for Fiber-Optic Connections](#) document.

Procedure

- Step 1** Remove the dust plugs from the optical network interface cable MPO connectors and from the transceiver module optical bores. Save the dust plugs for future use.
- Step 2** Attach the network interface cable MPO connectors immediately to the transceiver module.

Figure 105: Cabling a Transceiver Module

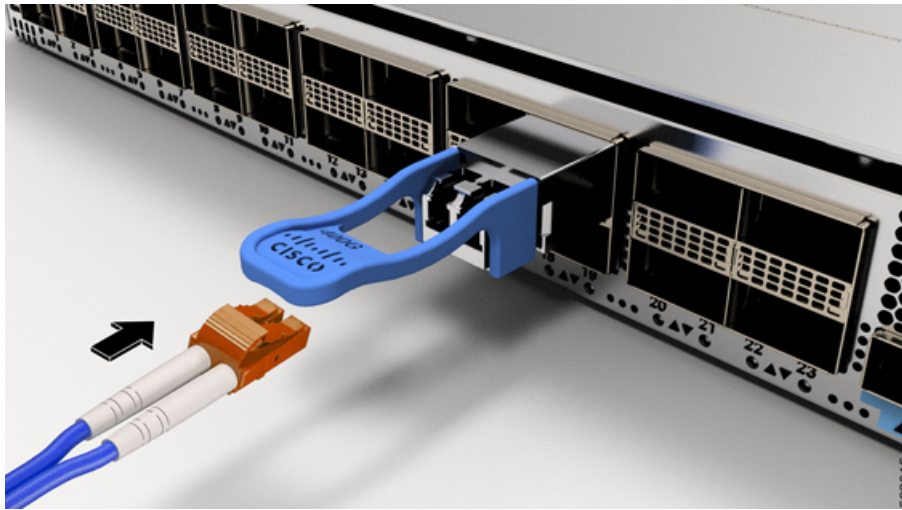

Removing the Transceiver Module



Warning **Statement 1055**—Class 1/1M Laser

Invisible laser radiation is present. Do not expose to users of telescopic optics. This applies to Class 1/1M laser products.



Warning **Statement 1051**—Laser Radiation

Invisible laser radiation may be emitted from disconnected fibers or connectors. Do not stare into beams or view directly with optical instruments.



Warning **Statement 1079—Hot Surface**

This icon is a hot surface warning. To avoid personal injury, do not touch without proper protection.



Caution The transceiver module is a static-sensitive device. Always use an ESD wrist strap or similar individual grounding device when handling transceiver modules or coming into contact with modules.

Caution Protect the transceiver ports by inserting clean dust caps (8000-QSFP-DCAP) into any ports not in use. Be sure to clean the optic surfaces of the fiber cables before you plug them back into the optical ports of another module. Use dust caps for all the open ports on the chassis.

The router ships with dust caps plugged in. We highly recommend you to keep the dust caps plugged in until you are ready to plug an optic.

The dust caps protect the ports from possible EMI interference and also avoid contamination due to dust collection. To meet the EMI interference requirements, you must use the metal dust caps when the ports are not in use by optical modules.

To remove a transceiver module, follow these steps:

Procedure

-
- Step 1** Disconnect the network interface cable from the transceiver connector.
 - Step 2** Install the dust plug immediately into the transceiver's optical bore.
 - Step 3** Grasp the pull-tab and gently pull to release the transceiver from the socket.

Figure 106: Removing the QSFP Transceiver Module

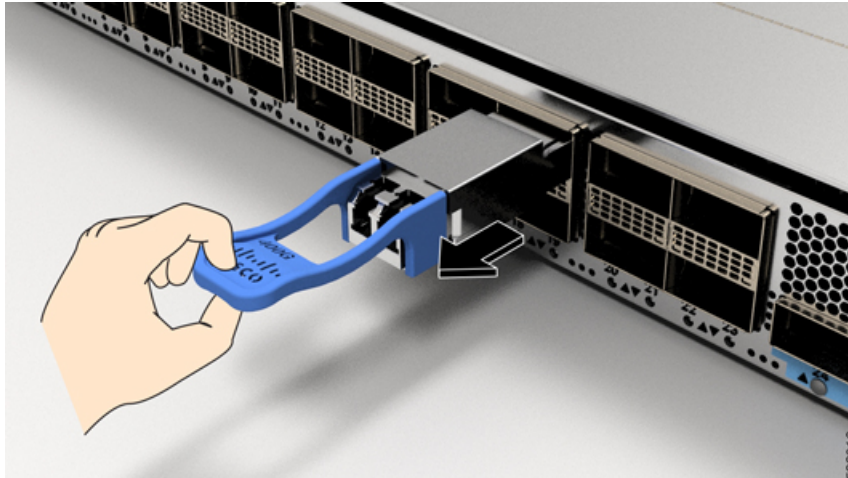

- Step 4** Slide the transceiver out of the socket.
- Step 5** Place the transceiver module into an antistatic bag.
-

Connect Interface Ports

You can connect optical interface ports on line cards with other devices for network connectivity.

Disconnect Optical Ports from the Network

When you need to remove fiber-optic transceivers, you must first remove the fiber-optic cables from the transceiver before you remove the transceiver from the port.

Maintain Transceivers and Optical Cables

Refer to [Inspection and Cleaning Procedures for Fiber-Optic Connections](#) document for inspection and cleaning processes for fiber optic connections.

Create the Initial Router Configuration

Assign an IP address to the router management interface to connect the router to the network.

When you initially power up the router, it boots up and displays a series of configuration-related questions. You can use the default choices for each configuration except for the IP address, which you must provide.

**Note**

- These routers are designed to boot up in less than 30 mins, provided the neighboring devices are in full-operational state.
- When the router is powered on and the console port is connected to the terminal, the RP CPU messages are seen.
- The Cisco 8608 router doesn't support BMC.

Before you begin

- A console device must be connected with the router.
- The router must be connected to a power source.
- Determine the IP address and netmask that is needed for the Management interfaces: `MgmtEth0/RP0/CPU0/0` and `MgmtEth0/RP1/CPU0/0`:

Procedure

Step 1 Power up the router.

The LEDs on each power supply light up (green) when the power supply units are sending power to the router, and the software asks you to specify a password to use with the router.

Step 2 When the system boots up for the first time, the system prompts you to create a new username and password. The following prompt appears:

```
!!!!!!!!!!!!!!!!!!!!!! NO root-system username is configured. Need to configure root-system
username. !!!!!!!!!!!!!!!!!!!!!!!
```

```
--- Administrative User Dialog ---
```

```
Enter root-system username:
% Entry must not be null.
```

```
Enter root-system username: cisco
Enter secret:
Use the 'configure' command to modify this configuration.
User Access Verification
```

```
Username: cisco
Password:
```

```
RP/0/RP0/CPU0:ios#
```

Step 3 Enter a new password to use for this router.

The software checks the security strength of your password and rejects your password if the system doesn't consider it as a strong password. To increase the security strength of your password, ensure that it adheres to the following guidelines:

- At least eight characters
- Minimizes or avoids the use of consecutive characters (such as "abcd")
- Minimizes or avoids repeating characters (such as "AAA")
- Doesn't contain recognizable words in the dictionary
- Doesn't contain proper names
- Contains both uppercase and lowercase characters
- Contains numbers and letters

Note Cleartext passwords can't include the dollar sign (\$) special character.

Tip If a password is trivial (such as a short, easy-to-decipher password), the software rejects that password. Passwords are case-sensitive.

When you enter a strong password, the software asks you to confirm the password.

Step 4 Reenter the password.

When you enter the same password, the software accepts the password.

Step 5 Enter the configuration mode.

Step 6 Enter the IP address for the management interface. If using dual RPs, enter the IP address on both management interfaces.

Step 7 Enter a network mask for the management interface.

Step 8 Save your configuration.

Step 9 The software asks whether you want to edit the configuration.

- **no** - select this option if you don't want to edit your configuration.
- **yes** - select this option if you want to edit your configuration.

Note We recommend that you configure the system location altitude for fan control. This configuration allows you to specify the chassis altitude, so the router can adjust the fan speed to compensate for lower cooling capability at higher altitudes. For more details, see the [environment altitude](#) command.

Verify Chassis Installation

After installing the chassis, use the following **show** commands to verify the installation and configuration in the EXEC mode. Any issue if detected, take corrective action before making further configurations.

Command	Description
show platform	Displays the state information of each card.
show redundancy	Displays the status of route processor redundancy.
show led	Displays LED information for the router, or for a specific LED location.

Command	Description
show hw-module fpd	Displays field-programmable device (FPD) compatibility for all modules or a specific module.
show alarms brief system active	Displays all existing alarms in the router.
show media	Displays the current state of the disk storage media.
show inventory	Displays information about the field replaceable units (FRUs), including product IDs, serial numbers, and version IDs.
show environment power	Displays the power usage information for the entire router.
show environment fan	Displays the status of the fan trays.
show environment temperature	<p>Displays temperature readings for card temperature sensors. Each module has temperature sensors with two thresholds:</p> <ul style="list-style-type: none"> • Minor temperature threshold – When a minor threshold is exceeded, minor alarm occurs and the following actions occur for all four sensors: <ul style="list-style-type: none"> • Displays system messages • Sends SNMP notifications (if configured) • Log environmental alarm event that can be reviewed by running the show alarm command. • Major temperature threshold – When a major threshold is exceeded, a major alarm occurs and the following actions occur: <ul style="list-style-type: none"> • For sensors 1, 3, and 4 (outlet and on board sensors), the following actions occur: <ul style="list-style-type: none"> • Displays system messages. • Sends SNMP notifications (if configured). • Logs environmental alarm event that can be reviewed by running the show alarm command. • For sensor 2 (intake sensor), the following actions occur: <ul style="list-style-type: none"> • If the threshold is exceeded in a switching card, only that card is shut down. • If the threshold exceeds an active Route Processor card with HA-standby or standby present, only that Route Processor card is shut down and the standby Route Processor card takes over. • If you do not have a standby Route Processor card in your router, you have up to 2 minutes to decrease the temperature. During this interval, the software monitors the temperature every 5 seconds and continuously sends system messages as configured. <p>Note</p> <ul style="list-style-type: none"> • Cisco recommends that you install dual Route Processor cards. • For some card temperature sensors, the temperature thresholds for both minor and major might display 'NA'. This is an expected behaviour and indicates that there are no alarms for those corresponding thresholds.

Command	Description
show environment voltage	Displays the voltage for the entire router.
show environment current	Displays the current environment status.
show platform domain	Displays the active and standby modes of Route Processor Cards and Switch Cards.

show platform command

The following example shows a sample output from the **show platform** command:

```
Router#show platform
Wed Jul 12 14:36:14.897 UTC
Node                Type                State                Config state
-----
0/RP0/CPU0          8608-RP (Active)    IOS XR RUN           NSHUT
0/RP1/CPU0          8608-RP (Standby)  IOS XR RUN           NSHUT
0/SC0               8608-SC0-128       OPERATIONAL          NSHUT
0/SC1               8608-SC0-128       OPERATIONAL          NSHUT
0/FB0               8608-SC0-128 [FB]  OPERATIONAL          NSHUT
0/FB1               8608-SC0-128 [FB]  OPERATIONAL          NSHUT
0/0                 86-MPA-4FH-M        OPERATIONAL          NSHUT
0/3                 86-MPA-14H2FH-M    OPERATIONAL          NSHUT
0/FT0               8608-FAN             OPERATIONAL          NSHUT
0/FT1               8608-FAN             OPERATIONAL          NSHUT
0/FT2               8608-FAN             OPERATIONAL          NSHUT
0/FT3               8608-FAN             OPERATIONAL          NSHUT
0/FT4               8608-FAN             OPERATIONAL          NSHUT
0/FT5               8608-FAN             OPERATIONAL          NSHUT
0/FT6               8608-FAN             OPERATIONAL          NSHUT
0/FT7               8608-FAN             OPERATIONAL          NSHUT
0/PM0               PSU3.2KW-ACPI        OPERATIONAL          NSHUT
0/PM1               PSU3.2KW-ACPI        OPERATIONAL          NSHUT
```

show redundancy command

The following example shows a sample output from the **show redundancy** command:

```
Router#show redundancy
Wed Jul 12 14:41:17.597 UTC
Redundancy information for node 0/RP0/CPU0:
=====
Node 0/RP0/CPU0 is in ACTIVE role
Partner node (0/RP1/CPU0) is in STANDBY role
Standby node in 0/RP1/CPU0 is ready
Standby node in 0/RP1/CPU0 is NSR-ready

Reload and boot info
-----
RP reloaded Wed Jul 12 14:01:06 2023: 40 minutes ago
Active node booted Wed Jul 12 14:01:06 2023: 40 minutes ago
Standby node boot Mon Jan 1 19:13:53 2018: 5 years, 27 weeks, 3 days, 19 hours, 27 minutes ago
Standby node last went not ready Wed Jul 12 14:04:03 2023: 37 minutes ago
Standby node last went ready Wed Jul 12 14:05:50 2023: 35 minutes ago
```

Standby node last went not NSR-ready Wed Jul 12 14:03:46 2023: 37 minutes ago
 Standby node last went NSR-ready Wed Jul 12 14:08:20 2023: 32 minutes ago
 There have been 0 switch-overs since reload

Active node reload "0/SC0 reload triggered graceful chassis reload"
 Standby node reload "0/SC0 reload triggered graceful chassis reload"

show led command

The following example shows a sample output from the **show led** command:

```
Router#show led
Wed Jul 12 14:41:20.426 UTC
=====
Location          LED Name          Mode          Color
=====
0
0/0               Attention         OPERATIONAL  OFF
                 Status           OPERATIONAL  GREEN
0/3               Attention         OPERATIONAL  OFF
                 Status           OPERATIONAL  GREEN
0/FB0             Attention         OPERATIONAL  OFF
                 Status           OPERATIONAL  GREEN
0/FB1             Attention         OPERATIONAL  OFF
                 Status           OPERATIONAL  GREEN
0/FT0             Status/Attention OPERATIONAL  GREEN
0/FT1             Status/Attention OPERATIONAL  GREEN
0/FT2             Status/Attention OPERATIONAL  GREEN
0/FT3             Status/Attention OPERATIONAL  GREEN
0/FT4             Status/Attention OPERATIONAL  GREEN
0/FT5             Status/Attention OPERATIONAL  GREEN
0/FT6             Status/Attention OPERATIONAL  GREEN
0/FT7             Status/Attention OPERATIONAL  GREEN
0/PM0             Attention         OPERATIONAL  OFF
                 Fault           OPERATIONAL  OFF
                 Input          OPERATIONAL  GREEN
                 Output         OPERATIONAL  GREEN
0/PM1             Attention         OPERATIONAL  OFF
                 Fault           OPERATIONAL  OFF
                 Input          OPERATIONAL  GREEN
                 Output         OPERATIONAL  GREEN
0/RP0/CPU0       Attention         OPERATIONAL  OFF
                 BITS           OPERATIONAL  OFF
                 GNSS           OPERATIONAL  OFF
                 GPS            OPERATIONAL  OFF
                 RP-Active     OPERATIONAL  GREEN
                 Status        OPERATIONAL  BLINKING RED
```

	Sync	OPERATIONAL	OFF
	Timing-PTP	OPERATIONAL	OFF
0/RP1/CPU0	Attention	OPERATIONAL	OFF
	BITS	OPERATIONAL	OFF
	GNSS	OPERATIONAL	OFF
	GPS	OPERATIONAL	OFF
	RP-Active	OPERATIONAL	OFF
	Status	OPERATIONAL	GREEN
	Sync	OPERATIONAL	OFF
	Timing-PTP	OPERATIONAL	OFF
0/SC0	Attention	OPERATIONAL	OFF
	Status	OPERATIONAL	GREEN
0/SC1	Attention	OPERATIONAL	OFF
	Status	OPERATIONAL	GREEN

show hw-module fpd command

The following example shows a sample output from the **show hw-module fpd** command:

```
Router#show hw-module fpd
Wed Jul 12 14:41:23.437 UTC
```

Auto-upgrade:Enabled

Attribute codes: B golden, P protect, S secure, A Anti Theft aware

Location	Card type	HWver	FPD device	ATR	Status	FPD Versions =====	
Reload Loc						Running	Programd
0/RP0/CPU0	8608-RP	1.0	Bios	S	CURRENT	1.09	1.09
0/RP0/CPU0	8608-RP	1.0	BiosGolden	BS	CURRENT		1.01
0/RP0/CPU0	8608-RP	1.0	IoFpga	S	CURRENT	1.09	1.09
0/RP0/CPU0	8608-RP	1.0	IoFpgaGolden	BS	CURRENT		1.09
0/RP0/CPU0	8608-RP	1.0	SsdMicron7300M2		CURRENT	2.60	2.60
0/RP0/CPU0	8608-RP	1.0	x86Fpga	S	CURRENT	1.07	1.07
0/RP0/CPU0	8608-RP	1.0	x86FpgaGolden	BS	CURRENT		1.07
0/RP0/CPU0	8608-RP	1.0	x86TamFw	S	CURRENT	7.12	7.12
0/RP0/CPU0	8608-RP	1.0	x86TamFwGolden	BS	CURRENT		7.12
0/RP1/CPU0	8608-RP	1.0	Bios	S	CURRENT	1.09	1.09
0/RP1/CPU0	8608-RP	1.0	BiosGolden	BS	CURRENT		1.01
0/RP1/CPU0	8608-RP	1.0	IoFpga	S	CURRENT	1.09	1.09
0/RP1/CPU0	8608-RP	1.0	IoFpgaGolden	BS	CURRENT		1.09
0/RP1/CPU0	8608-RP	1.0	SsdMicron7300M2		CURRENT	2.60	2.60
0/RP1/CPU0	8608-RP	1.0	x86Fpga	S	CURRENT	1.07	1.07
0/RP1/CPU0	8608-RP	1.0	x86FpgaGolden	BS	CURRENT		1.07

```

0/RP1
0/RP1/CPU0 8608-RP          1.0  x86TamFw          S  CURRENT  7.12  7.12
0/RP1
0/RP1/CPU0 8608-RP          1.0  x86TamFwGolden    BS  CURRENT           7.12
0/RP1
0/PM0      PSU3.2KW-ACPI          1.0  EM-LogicMCU       CURRENT  0.10  0.10
NOT REQ
0/PM0      PSU3.2KW-ACPI          1.0  EM-PrimMCU        CURRENT  0.02  0.02
NOT REQ
0/PM0      PSU3.2KW-ACPI          1.0  EM-SecMCU         CURRENT  0.02  0.02
NOT REQ
0/PM1      PSU3.2KW-ACPI          1.0  EM-LogicMCU       CURRENT  0.10  0.10
NOT REQ
0/PM1      PSU3.2KW-ACPI          1.0  EM-PrimMCU        CURRENT  0.02  0.02
NOT REQ
0/PM1      PSU3.2KW-ACPI          1.0  EM-SecMCU         CURRENT  0.02  0.02
NOT REQ
0/0        86-MPA-4FH-M          1.0  IoFpga            S  CURRENT  1.02  1.02
0/0
0/0        86-MPA-4FH-M          1.0  IoFpgaGolden      BS  CURRENT           1.02
0/0
0/3        86-MPA-14H2FH-M      1.0  IoFpga            S  CURRENT  1.02  1.02
0/3
0/3        86-MPA-14H2FH-M      1.0  IoFpgaGolden      BS  CURRENT           1.02
0/3
0/SC0      8608-SC0-128          1.0  IoFpga            S  CURRENT  1.01  1.01
0/SC0
0/SC0      8608-SC0-128          1.0  IoFpgaGolden      BS  CURRENT           1.01
0/SC0
0/SC1      8608-SC0-128          1.0  IoFpga            S  CURRENT  1.01  1.01
0/SC1
0/SC1      8608-SC0-128          1.0  IoFpgaGolden      BS  CURRENT           1.01
0/SC1
0/FB0      8608-SC0-128 [FB]    1.0  IoFpga            CURRENT  1.10  1.10
NOT REQ
0/FB0      8608-SC0-128 [FB]    1.0  IoFpgaGolden      B  CURRENT           1.07
NOT REQ
0/FB1      8608-SC0-128 [FB]    1.0  IoFpga            CURRENT  1.10  1.10
NOT REQ
0/FB1      8608-SC0-128 [FB]    1.0  IoFpgaGolden      B  CURRENT           1.07
NOT REQ

```

show alarms brief system active command

The following example shows a sample output from the **show alarms brief system active** command:

```

Router#show alarms brief system active
Wed Jul 12 14:41:31.583 UTC

```

```

-----
Active Alarms
-----

```

Location	Severity	Group	Set Time	Description
0	Major	Environ	07/12/2023 14:03:04 UTC	Power Module redundancy lost



Note If there's a mismatch of the interface state between the active and standby modes of the components that are available on the front of the chassis, the router generates an alarm. For information on components available on the front of the chassis, see [Cisco 8600 Series Routers](#).

The following is an example of the alarms that are generated when there's an interface state mismatch between the active and standby modes for a component:

```
0/RP0/CPU0      Minor      Fabric      09/29/2021 00:22:48 UTC   Port 0/0/3/0 -
Interface: Intf state between active and standby npu drivers are inconsistent
09/29/2021 00:22:58 UTC
0/RP0/CPU0      Minor      Fabric      09/29/2021 00:22:48 UTC   Port 0/0/3/1 -
Interface: Intf state between active and standby npu drivers are inconsistent
09/29/2021 00:22:58 UTC
0/RP0/CPU0      Minor      Fabric      09/29/2021 00:22:48 UTC   Port 0/0/3/2 -
Interface: Intf state between active and standby npu drivers are inconsistent
```

show media command

The following example shows a sample output from the **show media** command:

```
Router#show media
Wed Jul 12 14:41:36.162 UTC

Media Info for Location: node0_RP0_CPU0
Partition          Size      Used  Percent  Avail
-----
rootfs:            71.6G    9.7G    13%      62G
data:              339.1G   2.7G    1%     336.5G
/var/lib/docker    9.4G     37M    1%      8.8G
disk0:             9.4G     37M    1%      8.8G
log:               9.4G    173M    2%      8.7G
harddisk:          71G     704M    2%      66G
```

show inventory command

The following example shows a sample output from the **show inventory** command:

```
Router#show inventory
Wed Jul 12 14:41:39.052 UTC
NAME: "Rack 0", DESCR: "Cisco 8600 - 8 Slot Centralized Chassis"
PID: 8608-SYS      , VID: V00, SN: FOX2635PQK0

NAME: "0/RP0/CPU0", DESCR: "Cisco 8608 Route Processor"
PID: 8608-RP      , VID: V01, SN: FOC2520N3KW

NAME: "0/RP1/CPU0", DESCR: "Cisco 8608 Route Processor"
PID: 8608-RP      , VID: V01, SN: FOC2520N3LT

NAME: "0/0", DESCR: "Cisco 8600 4x400G RedundantMPA"
PID: 86-MPA-4FH-M , VID: V01, SN: FOC2539NXBZ

NAME: "FourHundredGigE0/0/0/0", DESCR: "Non-Cisco QSFPDD 400G PASSIVE COPPER Pluggable
Optics Module"
PID: 2323766-2    , VID: 2, SN: 18169373

NAME: "FourHundredGigE0/0/0/1", DESCR: "Non-Cisco QSFPDD 400G PASSIVE COPPER Pluggable
```

Optics Module"
PID: 2323766-2 , VID: 2, SN: 18169373

NAME: "FourHundredGigE0/0/0/2", DESCR: "Non-Cisco QSFPDD 400G PASSIVE COPPER Pluggable Optics Module"
PID: 2323766-2 , VID: 2, SN: 18169307

NAME: "FourHundredGigE0/0/0/3", DESCR: "Non-Cisco QSFPDD 400G PASSIVE COPPER Pluggable Optics Module"
PID: 2323766-2 , VID: 2, SN: 18169307

NAME: "0/3", DESCR: "Cisco 8600 14x100G and 2x400G Combo Redundant MPA"
PID: 86-MPA-14H2FH-M , VID: V01, SN: FOC2448N8ZA

NAME: "HundredGigE0/3/0/9", DESCR: "Cisco QSFP28 100G SR4 Pluggable Optics Module"
PID: QSFP-100G-SR4-S , VID: V02, SN: AVF2202S1Y1

NAME: "HundredGigE0/3/0/2", DESCR: "Cisco QSFP28 100G SR4 Pluggable Optics Module"
PID: QSFP-100G-SR4-S , VID: V02, SN: AVF2227S0MZ

NAME: "HundredGigE0/3/0/8", DESCR: "Cisco QSFP28 100G SR4 Pluggable Optics Module"
PID: QSFP-100G-SR4-S , VID: V02, SN: AVF2144S2JH

NAME: "0/SC0", DESCR: "Cisco 8608 12.8T Switch Card"
PID: 8608-SC0-128 , VID: V01, SN: FOC2708N583

NAME: "0/SC1", DESCR: "Cisco 8608 12.8T Switch Card"
PID: 8608-SC0-128 , VID: V01, SN: FOC2708N57N

NAME: "0/FB0", DESCR: "8608 Fan Controller Board on 8608-SC0-128"
PID: 8608-SC0-128[FB] , VID: V01, SN: FOC2708N52Y

NAME: "0/FB1", DESCR: "8608 Fan Controller Board on 8608-SC0-128"
PID: 8608-SC0-128[FB] , VID: V01, SN: FOC2708N24B

NAME: "0/FT0", DESCR: "CISCO 8608 FAN"
PID: 8608-FAN , VID: V01, SN: NCV26307038

NAME: "0/FT1", DESCR: "CISCO 8608 FAN"
PID: 8608-FAN , VID: V01, SN: NCV26307054

NAME: "0/FT2", DESCR: "CISCO 8608 FAN"
PID: 8608-FAN , VID: V01, SN: NCV26307046

NAME: "0/FT3", DESCR: "CISCO 8608 FAN"
PID: 8608-FAN , VID: V01, SN: NCV2630703U

NAME: "0/FT4", DESCR: "CISCO 8608 FAN"
PID: 8608-FAN , VID: V01, SN: NCV2630701R

NAME: "0/FT5", DESCR: "CISCO 8608 FAN"
PID: 8608-FAN , VID: V01, SN: NCV2630705C

NAME: "0/FT6", DESCR: "CISCO 8608 FAN"
PID: 8608-FAN , VID: V01, SN: NCV26307048

NAME: "0/FT7", DESCR: "CISCO 8608 FAN"
PID: 8608-FAN , VID: V01, SN: NCV2630705S

NAME: "0/PM0", DESCR: "Cisco 3.2KW AC Power Supply Unit"
PID: PSU3.2KW-ACPI , VID: V01, SN: ART2522B035

NAME: "0/PM1", DESCR: "Cisco 3.2KW AC Power Supply Unit"
PID: PSU3.2KW-ACPI , VID: V01, SN: ART2546B00S

show environment power command

The following example shows a sample output from the **show environment power** command:

```
Router#show environment power
Wed Jul 12 14:41:45.688 UTC
=====
CHASSIS LEVEL POWER INFO: 0
=====
Total output power capacity (N + 1)      : 6400W + 0W
Total output power required              : 4412W
Total power input                        : 787W
Total power output                       : 705W
=====

Power      Supply      -----Input-----  -----Output---      Status
Module     Type                Volts    Amps    Volts    Amps
=====
0/PM0      PSU3.2KW-ACPI      213.2    2.0    54.7    6.9    OK
0/PM1      PSU3.2KW-ACPI      212.6    1.7    54.7    6.0    OK

Total of Power Modules:                787W/3.7A                705W/12.9A
=====

Location   Card Type                Power      Power      Status
                Allocated  Used
                Watts      Watts
=====
0/RP0/CPU0 8608-RP                  200        49        ON
0/RP1/CPU0 8608-RP                  200        49        ON
0/SC0      8608-SC0-128            550        168       ON
0/SC1      8608-SC0-128            550        166       ON
0/FB0      8608-SC0-128 [FB]       10         -         ON
0/FB1      8608-SC0-128 [FB]       10         -         ON
0/0        86-MPA-4FH-M            350        125       ON
0/1        -                        32         -         RESERVED
0/2        -                        32         -         RESERVED
0/3        86-MPA-14H2FH-M        350        159       ON
0/4        -                        32         -         RESERVED
0/5        -                        32         -         RESERVED
0/6        -                        32         -         RESERVED
0/7        -                        32         -         RESERVED
0/FT0      8608-FAN                250        10        ON
0/FT1      8608-FAN                250        9         ON
0/FT2      8608-FAN                250        10        ON
0/FT3      8608-FAN                250        10        ON
0/FT4      8608-FAN                250        10        ON
0/FT5      8608-FAN                250        9         ON
0/FT6      8608-FAN                250        10        ON
0/FT7      8608-FAN                250        10        ON
```

show environment fan command

The following example shows a sample output from the **show environment fan** command:

```
Router#show environment fan
Wed Jul 12 14:41:50.676 UTC
=====
Location      FRU Type                Fan speed (rpm)
                FAN_0    FAN_1
=====
```

```

0/FT0      8608-FAN      2880    2850
0/FT1      8608-FAN      2820    2880
0/FT2      8608-FAN      2820    2820
0/FT3      8608-FAN      2880    2910
0/FT4      8608-FAN      2880    2910
0/FT5      8608-FAN      2850    2850
0/FT6      8608-FAN      2880    2910
0/FT7      8608-FAN      2910    2880
0/PM0      PSU3.2KW-ACPI  5247    5225
0/PM1      PSU3.2KW-ACPI  5247    5204 G

```

show environment temperature location *location* command

The following example shows a sample output from the **show environment temperature location** command. The location specified is **0/RP0/CPU0**:

```

Router#show environment temperature location 0/RP0/CPU0
Wed Jul 12 14:42:31.532 UTC

```

Location	TEMPERATURE	Value	Crit	Major	Minor	Minor
Major	Crit					
(Hi)	Sensor	(deg C)	(Lo)	(Lo)	(Lo)	(Hi)
(Hi)	(Hi)					

0/RP0/CPU0	Inlet_Temp	27	-10	0	5	NA
50	55					
	X86_CORE_5_T	67	-10	-5	0	NA
100	105					
	DIMM_TEMP1	38	-10	-5	0	NA
95	100					
	DIMM_TEMP2	37	-10	-5	0	NA
95	100					
	SSD_Temp	40	-10	-5	0	NA
80	83					
	T1_2PLUS1_TEMP	43	-10	0	5	NA
105	115					
	T1_1PLUS1_TEMP	39	-10	0	5	NA
105	115					
	Outlet_Temp	38	-10	-5	0	NA
110	115					
	Hot_Spot_Temp	40	NA	NA	NA	NA
NA	140					
	X86_PKG_TEMP	66	-10	-5	0	NA
100	105					
	X86_CORE_0_T	66	-10	-5	0	NA
100	105					
	X86_CORE_1_T	66	-10	-5	0	NA
100	105					
	X86_CORE_2_T	66	-10	-5	0	NA
100	105					
	X86_CORE_3_T	66	-10	-5	0	NA
100	105					
	X86_CORE_4_T	67	-10	-5	0	NA
100	105					

show environment voltage location location command

The following example shows a sample output from the **show environment voltage location** command. The location specified is **0/RP0/CPU0**:

```
Router#show environment voltage location 0/RP0/CPU0
Wed Jul 12 14:42:40.711 UTC
```

Location	VOLTAGE Sensor	Value (mV)	Crit (Lo)	Minor (Lo)	Minor (Hi)	Crit (Hi)

0/RP0/CPU0	P55V	55025	44400	53000	57000	60000
	P1V0_ADC	999	900	950	1050	1100
	P2V5_ADC	2514	2250	2375	2625	2750
	MGTAVTT_OMG_ADC	1196	1080	1140	1260	1320
	EN_VP3P3_ADC	3265	3003	3135	3465	3597
	P1V8_OMG_ADC	1800	1620	1710	1890	1980
	P0V9_ADC	894	810	855	945	990
	IBV	12000	10800	11040	12840	13200
	VP3P3_I210	3307	3003	3135	3465	3597
	VP1P0_VCS	998	910	950	1050	1090
	VP2P5_VCS	2509	2275	2375	2625	2725
	P3V3_ADC	3318	2970	3135	3465	3630
	VP1V8_ZL	1800	1638	1710	1890	1962
	VP3P3_ZL	3300	3003	3135	3465	3597
	VP1P8_OCXO	1800	1638	1710	1890	1962
	VP3P3_OCXO	3299	3003	3135	3465	3597
	VP3P89	3890	3610	3770	4010	4160
	VP3P3_STBY	3299	3003	3135	3465	3597
	VP2P5	2510	2275	2375	2625	2725
	VP3P3_HWL	3306	3003	3135	3465	3597
	VP7P0	7000	6300	6440	7560	7700
	VP3V3_GNSS	3307	3003	3135	3465	3597
	P5V0_ADC	5032	4550	4750	5250	5450
	VP5P0_ANT	5015	4550	4750	5250	5450
	VP1P3_CPU	1300	1183	1235	1365	1417
	VP1P5_CPU	1500	1350	1380	1620	1650
	VP1P7_CPU	1699	1590	1640	1760	1810
	VP3P3_CPU	3305	3003	3135	3465	3597
	VP1P8_CPU	1785	1638	1710	1890	1962
	VP0P6_A_CPU	592	540	552	648	660
	VP1P05_CPU	1050	950	970	1130	1160
	VP1P2_CPU	1197	1080	1100	1300	1320
	VP1P05_CPU_VCCSCSUS	1050	950	970	1130	1160
	P5VISO_ADC	5030	4550	4750	5250	5450
	VP1P2_CPUFPGA_CORE	1200	1080	1100	1300	1320
	VP3P3_SATA	3303	3003	3135	3465	3597
	PVCCIN	1783	1638	1710	1890	1962
	P1V05_VCCSCSUS	1050	950	970	1130	1160
	P1V2_VDDQ	1199	1080	1100	1300	1320
	P1V05_COMBINED	1050	950	970	1130	1160
	USB_5VA_ADC	5030	4550	4750	5250	5450
	P3V3_BPID_ADC	3315	3003	3135	3465	3597
	P5V0_CHLED_ADC	5032	4550	4750	5250	5450
	P1V0_MGT_ADC	999	900	950	1050	1100

show environment current location *location* command

The following example shows a sample output from the **show environment current location** command. The location specified is **0/RP0/CPU0**:

```
Router#show environment current location 0/RP0/CPU0
Wed Jul 12 14:42:48.023 UTC
```

Location	CURRENT Sensor	Value (mA)

0/RP0/CPU0	P55V_CURRENT	897
	CPU_CORE_CURRENT	11468
	P1V05_SUS_CURRENT	748
	DDR4_CURRENT	2058
	P1V05_IO_CURRENT	2335



Note To manually configure the environmental altitude of the chassis, use the [environment altitude](#) command.

show platform domain command

The following example shows a sample output from the **show platform domain** command:

```
Router#show platform domain
Wed Jul 19 21:50:13.913 UTC
ID  Name                Lead                HA Role            State
-----
```

1	DOMAIN_RP0_SC0	0/RP0/CPU0	ACTIVE	READY
2	DOMAIN_RP1_SC1	0/RP1/CPU0	STANDBY	READY



CHAPTER 6

Replace Chassis Components



Note The images in this chapter are only for representation purposes, unless specified otherwise. The chassis' actual appearance and size may vary.



Caution Whenever you replace any card, you must always ensure to secure the ejector thumbscrews properly.

- [Replace a Route Processor Card, on page 115](#)
- [Replace Modular Port Adapters, on page 120](#)
- [Replace a Switch Card, on page 125](#)
- [Replace a Fan Spinner, on page 129](#)
- [Replace a Fan Module, on page 131](#)
- [Replace Power Modules, on page 134](#)

Replace a Route Processor Card

The router supports up to two redundant Route Processor (RP) cards. When two RP cards are installed in the router, one acts as an active card and the other as the standby card. If the router has only one RP card installed, a new RP can be installed in the empty RP slot during operation.



-
- Note**
- The replacement procedure for the RP cards is only applicable to the standby RP card. You need to shutdown the router to replace an RP on a single-RP system. When you shutdown the standby RP card, the router automatically shuts down the standby Switch Card (SC) as both of them belong to the same operational domain. For example, when you shutdown RP0, the router shuts down the corresponding SC0. When you shutdown RP1, the router shuts down SC1.
 - To replace an active RP card, you must trigger a failover using the **redundancy switchover** command.
-



Warning Statement 1029—Blank Faceplates and Cover Panels

Blank faceplates and cover panels serve three important functions: they prevent exposure to hazardous voltages and currents inside the chassis; they contain electromagnetic interference (EMI) that might disrupt other equipment; and they direct the flow of cooling air through the chassis. Do not operate the system unless all cards, faceplates, front covers, and rear covers are in place.



Warning Statement 1034—Backplane Voltage

Hazardous voltage or energy is present on the backplane when the system is operating. Use caution when servicing

Before you begin

Before replacing the Route Processor (RP) card, you must perform a graceful shutdown of the card to avoid disk corruption. Use one of the following procedures to perform graceful shutdown of the card:

- unscrew the captive screws, pull the release latch down, and open ejector lever to trigger auto-shutdown of the card, and then verify that the Status LED is in Off state.
- use the **shutdown location** *location* command in admin EXEC mode to shutdown the card. Then use the **show platform** command to verify that the Status LED is in Off state.

Procedure

- Step 1** Open the packaging for the new RP card, inspect the card for damage, and verify that the card is the same type as the other RP cards installed in the chassis.
- If the RP card is damaged, alert the Technical Assistance Center (TAC).
- Step 2** If you are installing the RP card in an empty slot, remove the blank card that is already in that slot by unscrewing its captive screw and pulling it out of the slot. Go to Step 4.
- Step 3** If you are replacing an RP card that is currently in the chassis, remove the existing card from the chassis by following these steps:
- a) Disconnect the following cables from the card:
 - Console cable
 - Ethernet Management cable
 - b) If there are any external drives attached to the card through its USB ports, detach those drives.
 - c) Perform the graceful shutdown of the RP. Run the **shutdown location** *location* command in admin EXEC mode, which gracefully shuts down RP module to prevent any of the file systems from being corrupted.
 - d) Verify that the RP Status LED for the slot that you specified turns off. Also, you can verify that the card is in the powered off state by running the **show platform** command.
 - e) Rotate the captive screw, press the latch, and rotate the ejector lever away from the front of the card (see Callouts 1 and 2 in the following figure).

The card unseats its connectors from the midplane and moves slightly out of the chassis.

Figure 107: Remove Route Processor Card from Chassis

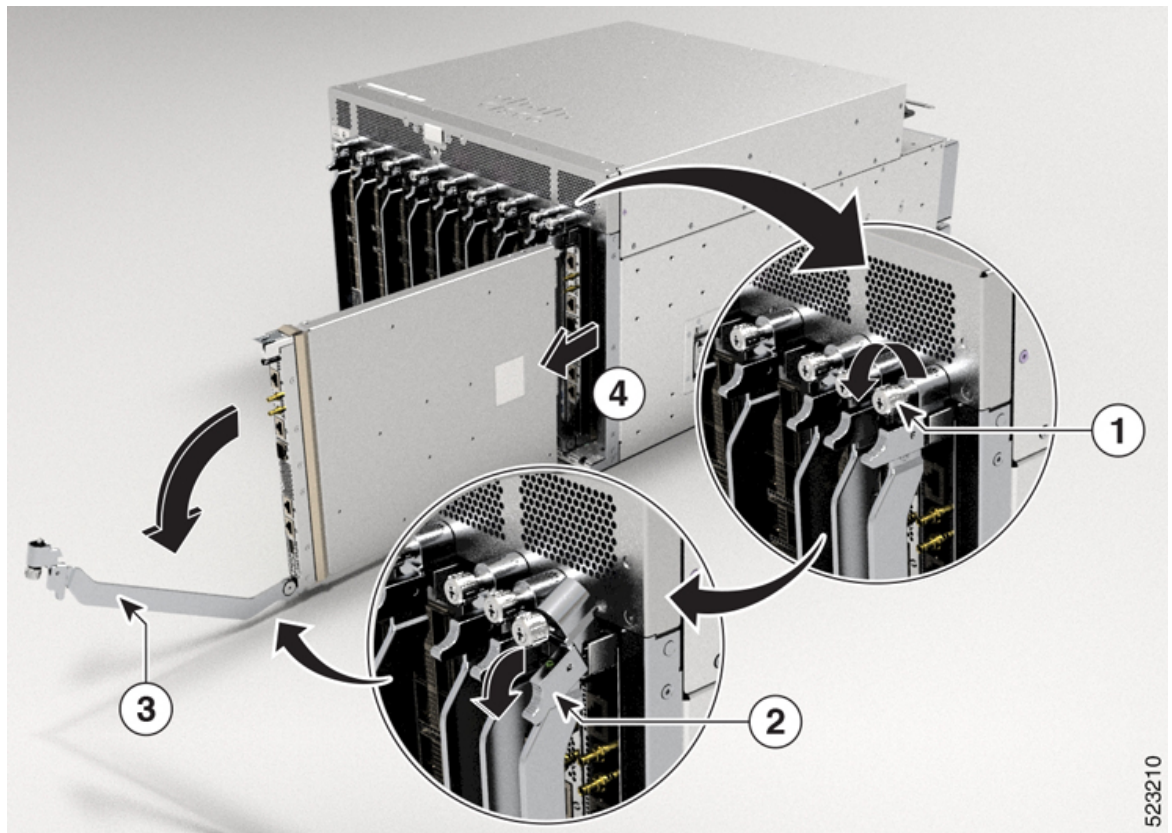

1	Unscrew the captive screw.	2	Release the latch.
3	Rotate the ejector lever away from the card.	4	Pull on the lever to slide the card partly out of the chassis. Release the lever, hold the front of the card, and pull the card all the way out of the chassis.

- f) Use one hand to hold the front of the card, place your other hand under the card to support its weight, pull the card out of the chassis, and set it on an antistatic surface or inside an antistatic bag.

Step 4 To install a new card, follow these steps:

- a) Pull the middle section of the ejector lever toward the end of the lever and rotate the lever away from the front of the card.

This action opens the lever so that the card can be fully inserted into the slot.

- b) Hold the front of the card with one hand and place your other hand under the card to support its weight.
- c) Align the back of the card to the guides in the open route processor slot and slide the card all the way into the slot (see the following figure).

The card stops when its front is about 0.25 inches (0.6 cm) outside the front of the chassis.

Figure 108: Install Route Processor Card into Chassis

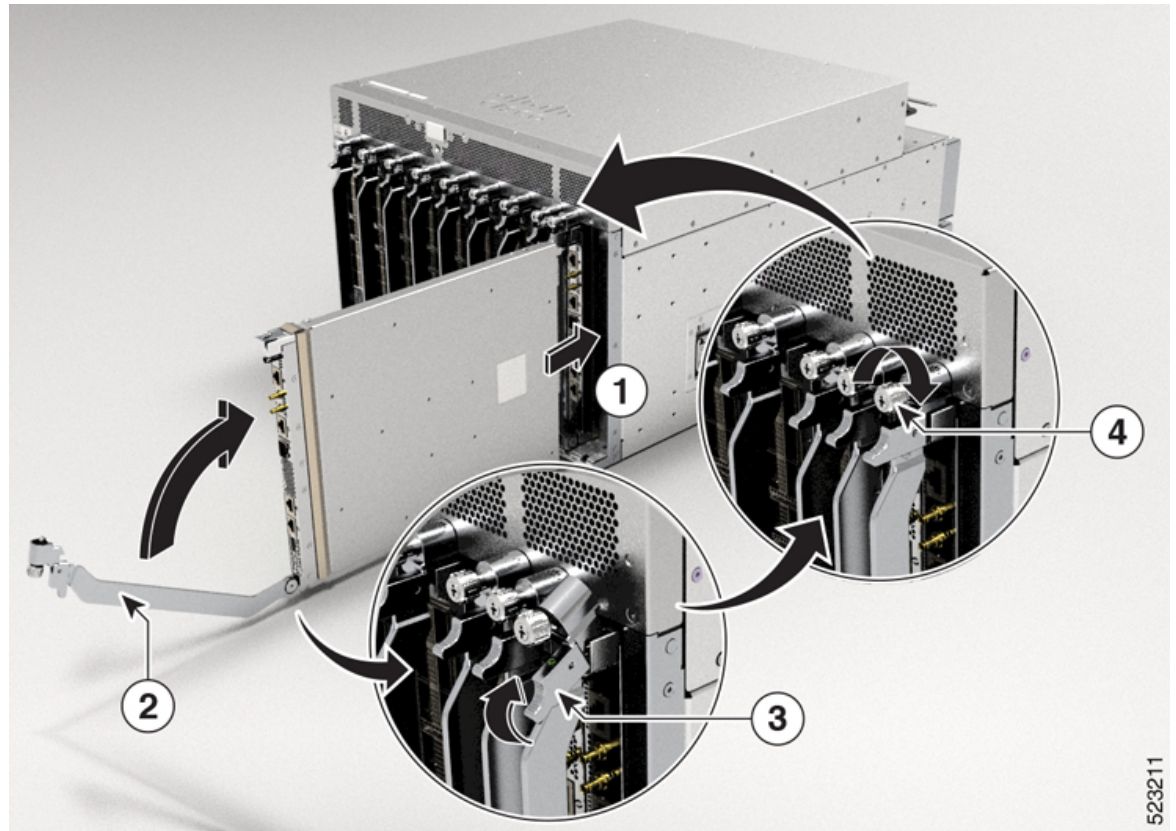

523211

1	Slide the back end of the card into the open route processor slot.	3	Press the latch upwards.
2	Rotate the ejector lever towards the card.	4	Rotate the captive screw to secure the route processor card.

- d) Rotate the lever all the way to the front of the chassis until it locks in place with a click.
Ensure that the other end of the lever engages behind the front of the slot so that the card fully seats onto the connectors on the midplane.
- e) Rotate the captive screw to secure the card to the chassis. Tighten the screws to 9.7 in-lbs (1.09 N-m) of torque.
- f) Attach the following cables to the card:
 - Console cable—Attach to the Console port.
 - Management cable—Attach to the Management Ethernet port.

Note Reload an RP card by using the **reload location** *location* command. Verify that the reloaded RP card is again in the Operational state by using the **show platform** command.

To verify the mode of RP card, if it is in standby or active mode, use the **show platform domain** command.

- g) Verify that the route processor card LEDs turn on and appear as follows:
- The Status LED is in solid amber color and later turns to solid green color.

Figure 109: Route Processor LEDs

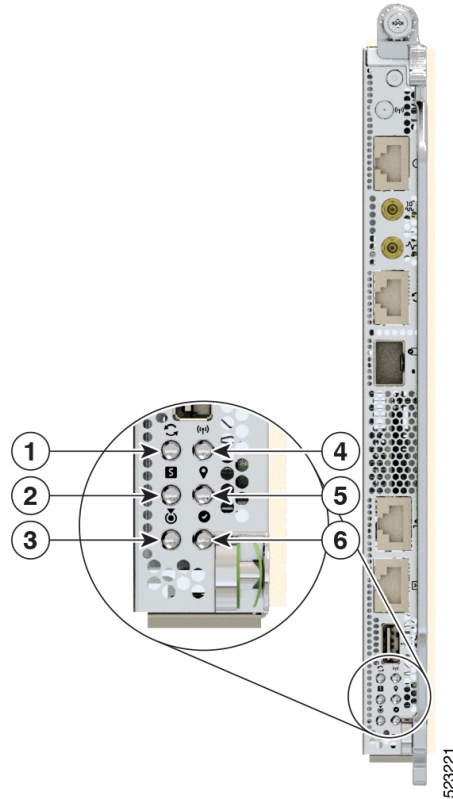

1	Sync
2	Status
3	Attention
4	Management Activity
5	GPS
6	Active

Migrating from Single Route Processor System to Dual-Route Processor System

The Cisco 8608 router supports a single Route Processor (RP) system and a dual Router Processor system. This section provides step-by-step instructions for migrating from a single-RP system to a dual-RP system.

1. From the SC slot, where you want to install a new SC, remove the fan trays, and then remove the Fan Spinner. For more information, see [Remove a Fan Spinner](#).
2. In the slot from where you removed the fan spinner, insert the standby Switch Card (SC). For more information, see [Install a Switch Card](#).
3. After you're done installing the SC, install the fan trays, and then install the RP card. For more information, see [Replace a Route Processor Card](#).

Migrating from Dual-Route Processor System to Single Route Processor System

This section provides step-by-step instructions for migrating from a dual-RP system to a single-RP system.

1. Remove the fan trays from the standby SC that you want to remove.
2. Remove the standby SC from the slot. For more information, see [Remove a Switch Card](#).
3. Install a Fan Spinner in the slot where you've removed the standby SC. For more information, see [Install a Fan Spinner](#).
4. After you're done installing the Fan Spinner, install the fan trays. For more information, see [Replace a Fan Module](#).

Replace Modular Port Adapters

The following sections describe how to remove or install an MPA:

Remove a Modular Port Adapter

Before you begin:

Before replacing the Modular Port Adapter (MPA), you must perform a graceful shutdown of the module to avoid disk corruption. Use one of the following procedures to perform graceful shutdown of the card:

- unscrew the captive screws, pull the release latch down, and open ejector lever to trigger auto-shutdown of the card, and then verify that the Status LED is in Off state.
- use the **shutdown location** *location* command in admin EXEC mode to shutdown the card. Then use the **show platform** command to verify that the Status LED is in Off state.

To remove an MPA, perform the following steps:

1. Ensure the router is in the NSR-ready state. Use the **show redundancy** command as shown in the following example:

```
Router#show redundancy
Thu Jun  1 21:44:12.842 UTC
Redundancy information for node 0/RP0/CPU0:
=====
Node 0/RP0/CPU0 is in ACTIVE role
Partner node (0/RP1/CPU0) is in STANDBY role
Standby node in 0/RP1/CPU0 is ready
Standby node in 0/RP1/CPU0 is NSR-ready

Reload and boot info
```

```

-----
RP reloaded Wed May 31 16:03:53 2023: 1 day, 5 hours, 40 minutes ago
Active node booted Wed May 31 16:03:53 2023: 1 day, 5 hours, 40 minutes ago
Standby node boot Wed May 31 16:04:06 2023: 1 day, 5 hours, 40 minutes ago
Standby node last went not ready Wed May 31 16:07:06 2023: 1 day, 5 hours, 37 minutes ago
Standby node last went ready Wed May 31 16:08:53 2023: 1 day, 5 hours, 35 minutes ago
Standby node last went not NSR-ready Wed May 31 16:06:49 2023: 1 day, 5 hours, 37 minutes ago
Standby node last went NSR-ready Wed May 31 16:13:26 2023: 1 day, 5 hours, 30 minutes ago
There have been 0 switch-overs since reload

Active node reload "User initiated chassis reload"
Standby node reload "User initiated chassis reload"
    
```

2. Perform the graceful shutdown of the MPA. Run the **shutdown location location** command in admin EXEC mode, which gracefully shuts down MPA to prevent any of the file systems from being corrupted.
3. Verify that the MPA Status LED for the slot that you specified turns off. Also, you can verify that the card is in the powered off state by running the **show platform** command.
4. To remove the MPA from the chassis, loosen the captive screws (marked as 1 in the image) on the MPA.
5. Press the tab down (marked as 2 in the image).
6. Pull the ejector lever away from the MPA (marked as 3 in the image).
7. Grasp the MPA and pull the MPA from the chassis (marked as 4 in the image). (You have already disconnected the cables from the MPA.)

Figure 110: Remove an MPA

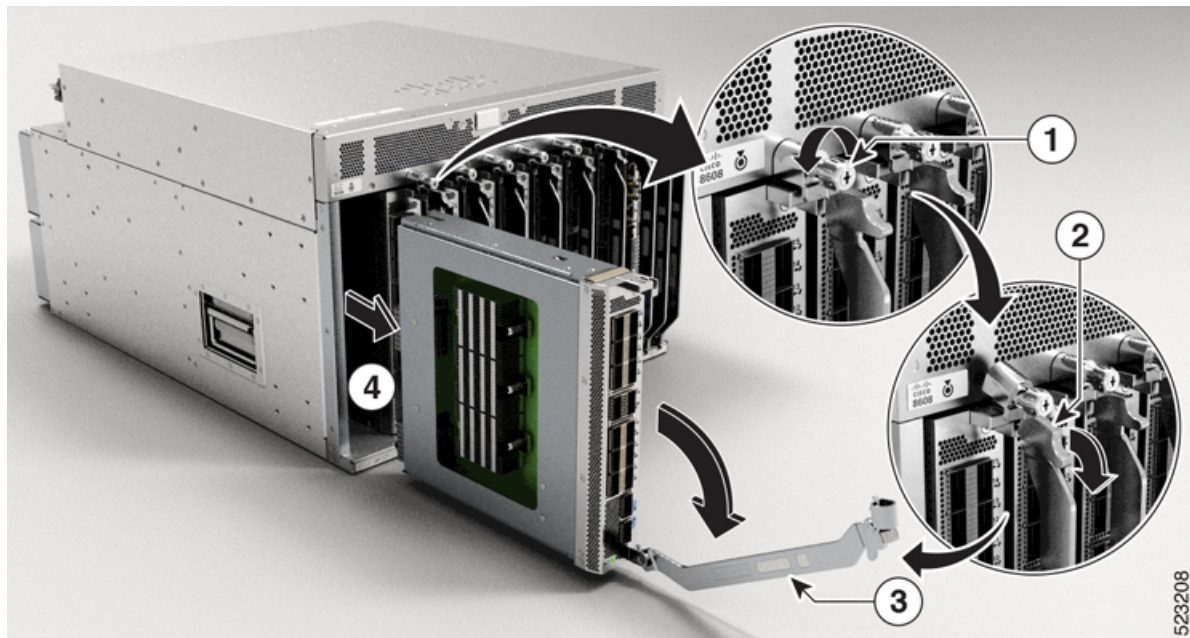

1	Rotate the captive screw to loosen the MPA.	2	Press the tab down.
3	Pull the ejector lever away from the MPA.		

- Verify that the router is in the NSR-ready state. Use the **show redundancy** command as shown in the following example:

```
Router#show redundancy
Thu Jun  1 21:52:36.811 UTC
Redundancy information for node 0/RP0/CPU0:
=====
Node 0/RP0/CPU0 is in ACTIVE role
Partner node (0/RP1/CPU0) is in STANDBY role
Standby node in 0/RP1/CPU0 is ready
Standby node in 0/RP1/CPU0 is NSR-ready

Reload and boot info
-----
RP reloaded Wed May 31 16:03:53 2023: 1 day, 5 hours, 48 minutes ago
Active node booted Wed May 31 16:03:53 2023: 1 day, 5 hours, 48 minutes ago
Standby node boot Wed May 31 16:04:06 2023: 1 day, 5 hours, 48 minutes ago
Standby node last went not ready Wed May 31 16:07:06 2023: 1 day, 5 hours, 45 minutes ago
Standby node last went ready Wed May 31 16:08:53 2023: 1 day, 5 hours, 43 minutes ago
Standby node last went not NSR-ready Wed May 31 16:06:49 2023: 1 day, 5 hours, 45 minutes ago
Standby node last went NSR-ready Wed May 31 16:13:26 2023: 1 day, 5 hours, 39 minutes ago
There have been 0 switch-overs since reload

Active node reload "User initiated chassis reload"
Standby node reload "User initiated chassis reload"
```

- Proceed with installing an MPA.

Install a Modular Port Adapter

This section provides step-by-step instructions for installing a modular port adapter (MPA) in a Cisco 8600 Series router.



Note After you remove the MPA from the slot, wait for 60 seconds before you reinsert an MPA.



Warning During this procedure, wear grounding wrist straps to avoid ESD damage to the card. Do not directly touch the backplane with your hand or any metal tool, or you could shock yourself. Statement 94

To install an MPA, perform the following steps:

- Ensure the router is in the NSR-ready state. Use the **show redundancy** command as shown in the following example:

```
Router#show redundancy
Thu Jun  1 21:44:12.842 UTC
Redundancy information for node 0/RP0/CPU0:
=====
Node 0/RP0/CPU0 is in ACTIVE role
Partner node (0/RP1/CPU0) is in STANDBY role
Standby node in 0/RP1/CPU0 is ready
Standby node in 0/RP1/CPU0 is NSR-ready
```



```
Reload and boot info
```

```
-----
```

```
RP reloaded Wed May 31 16:03:53 2023: 1 day, 5 hours, 40 minutes ago
Active node booted Wed May 31 16:03:53 2023: 1 day, 5 hours, 40 minutes ago
Standby node boot Wed May 31 16:04:06 2023: 1 day, 5 hours, 40 minutes ago
Standby node last went not ready Wed May 31 16:07:06 2023: 1 day, 5 hours, 37 minutes ago
Standby node last went ready Wed May 31 16:08:53 2023: 1 day, 5 hours, 35 minutes ago
Standby node last went not NSR-ready Wed May 31 16:06:49 2023: 1 day, 5 hours, 37 minutes ago
Standby node last went NSR-ready Wed May 31 16:13:26 2023: 1 day, 5 hours, 30 minutes ago
There have been 0 switch-overs since reload
```

```
Active node reload "User initiated chassis reload"
Standby node reload "User initiated chassis reload"
```

2. To insert the MPA, locate the guide rails inside the chassis that hold the MPA in place.
3. Carefully slide the MPA all the way in the chassis until the MPA is firmly seated in the MPA interface connector. When fully seated, the MPA might be slightly behind the faceplate.



Note The MPA will slide easily into the slot if it is properly aligned on the tracks. If the MPA does not slide easily, do NOT force it. Remove the MPA and reposition it, paying close attention to engaging it on the tracks. Push the MPA inside the slot until you hear a click. Continue to push the MPA further until you hear a second click. The MPA is fully seated only after the second click is heard.

4. After the MPA is properly seated, pull the ejector lever towards the chassis (marked as 2 in the image).
5. Pull the tab up (marked as 3 in the image).
6. Use a number 2 Phillips screwdriver to tighten the captive screws (marked as 4 in the image) on the MPA.

Figure 111: Install an MPA

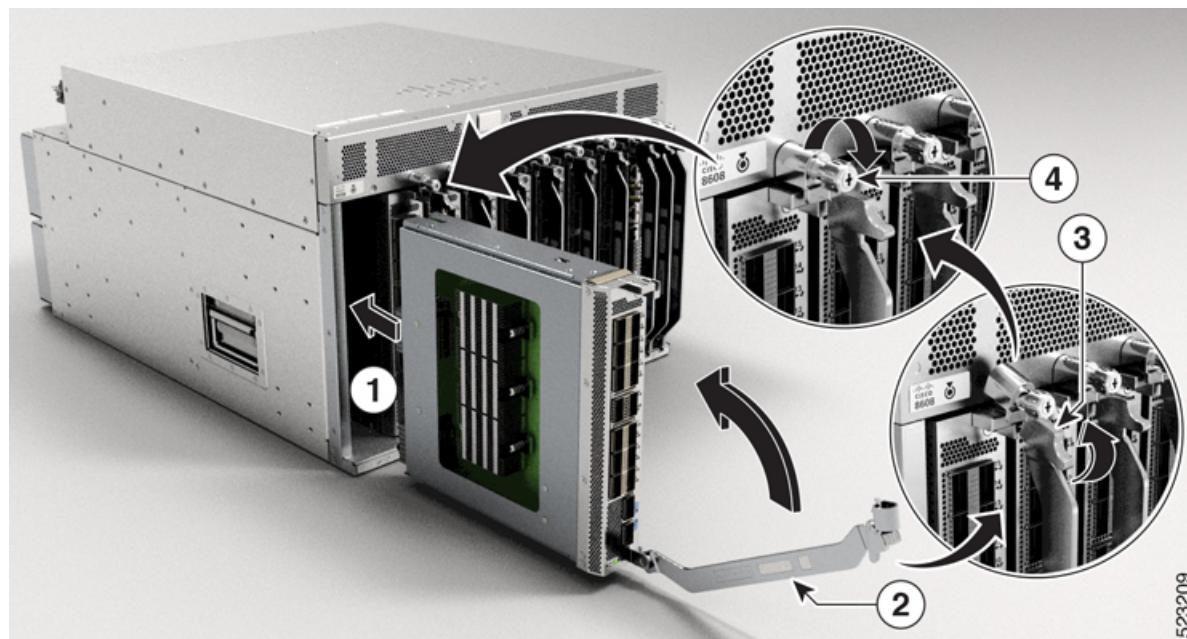

1	Slide the back end of the MPA into the open MPA slot.	2	Pull the ejector lever towards the MPA.
3	Pull the tab up.	4	Rotate the captive screw to tighten the MPA.



Note Tighten the captive screws on the MPA within 10 seconds.



Note Do not over-torque the MPA captive screws when installing the MPA. Tighten the captive screws on the MPA to a torque of 9.7 in-lbs (1.09 N-m).

7. Verify that after you've installed MPA, the router is in the NSR-ready state. Use the **show redundancy** command as shown in the following example:

```
Router#show redundancy
Thu Jun  1 21:52:36.811 UTC
Redundancy information for node 0/RP0/CPU0:
=====
Node 0/RP0/CPU0 is in ACTIVE role
Partner node (0/RP1/CPU0) is in STANDBY role
Standby node in 0/RP1/CPU0 is ready
Standby node in 0/RP1/CPU0 is NSR-ready

Reload and boot info
-----
RP reloaded Wed May 31 16:03:53 2023: 1 day, 5 hours, 48 minutes ago
Active node booted Wed May 31 16:03:53 2023: 1 day, 5 hours, 48 minutes ago
Standby node boot Wed May 31 16:04:06 2023: 1 day, 5 hours, 48 minutes ago
Standby node last went not ready Wed May 31 16:07:06 2023: 1 day, 5 hours, 45 minutes ago
Standby node last went ready Wed May 31 16:08:53 2023: 1 day, 5 hours, 43 minutes ago
Standby node last went not NSR-ready Wed May 31 16:06:49 2023: 1 day, 5 hours, 45 minutes ago
Standby node last went NSR-ready Wed May 31 16:13:26 2023: 1 day, 5 hours, 39 minutes ago
There have been 0 switch-overs since reload

Active node reload "User initiated chassis reload"
Standby node reload "User initiated chassis reload"
```



Note After you install an MPA, you can use the **show interfaces** command to verify the traffic on that MPA.

Replace a Switch Card



Warning **Statement 1090**—Installation by Skilled Person

Only a skilled person should be allowed to install, replace, or service this equipment. See statement 1089 for the definition of a skilled person.

There are no serviceable parts inside. To avoid risk of electric shock, do not open.



Warning **Statement 1091**—Installation by an Instructed Person

Only an instructed person or skilled person should be allowed to install, replace, or service this equipment. See statement 1089 for the definition of an instructed or skilled person.

There are no serviceable parts inside. To avoid risk of electric shock, do not open.



Warning **Statement 1073**—No User-Serviceable Parts

There are no serviceable parts inside. To avoid risk of electric shock, do not open.



Warning **Statement 1029**—Blank Faceplates and Cover Panels

Blank faceplates and cover panels serve three important functions: they prevent exposure to hazardous voltages and currents inside the chassis; they contain electromagnetic interference (EMI) that might disrupt other equipment; and they direct the flow of cooling air through the chassis. Do not operate the system unless all cards, faceplates, front covers, and rear covers are in place.



Warning **Statement 1034**—Backplane Voltage

Hazardous voltage or energy is present on the backplane when the system is operating. Use caution when servicing



Warning **Statement 1051**—Laser Radiation

Invisible laser radiation may be emitted from disconnected fibers or connectors. Do not stare into beams or view directly with optical instruments.

Before you begin:

Before replacing a Switch Card (SC), you must perform a graceful shutdown of the card to avoid disk corruption. Use one of the following procedures to perform graceful shutdown of the card:

- unscrew the captive screws and open ejector handles to trigger auto-shutdown of the card, and then verify that the Status LED is in Off state.
- use the **shutdown location** *location* command in admin EXEC mode to shutdown the card. Then use the **show platform** command to verify that the Status LED is in Off state.



Note The replacement procedure for the SC is only applicable to the standby SC card. Replacement of a standby SC requires you to shutdown the router. When you shutdown the standby SC, the router automatically shuts down the standby Route Processor (RP) card as both of them belong to the same operational domain. For example, when you shutdown RP0, the router shuts down the corresponding SC0. When you shutdown RP1, the router shuts down SC1. Similarly, when you reload RP1, the router reloads SC1. When you reload RP0, the router reloads SC0.

To replace the SC, you must do the following:

1. Shut down the SC being replaced. Use the **shutdown location** *location* command in admin EXEC mode, which gracefully shuts down the SC module. Shutdown the RP-SC domain of the SC being replaced with the location of the RP.
Or, unscrew the captive screws and open ejector handles to trigger auto-shutdown of the card, and then verify that the Status LED is in Off state.
2. Verify that the SC Status LED for the slot that you specified turns off. Also, you can verify that the card is in powered off state by running the **show platform** command.
3. Remove the SC. For more information, see [Remove a Switch Card](#).
4. Install the new SC. For more information, see [Install a Switch Card](#).
5. Reload the SC. To bring up the RP-SC domain to an operational state, reload the RP-SC domain by using **reload location** *location* with the location of the RP.
6. Verify that the reloaded SC is again in the Operational state by using the **show platform** command.
To verify the mode of SC, if it is in standby or active mode, use the **show platform domain** command.



Caution A fully loaded SC (with fans) weighs 27 lbs (12.25 kg). An empty SC (no fans) weighs 21.8 lbs (9.89 kg).

Remove a Switch Card

Before you begin

- You must wear an electrostatic discharge (ESD) wrist strap or other ESD protective device while handling modules.
- Prepare an antistatic surface or packing materials for each module that you remove from the chassis.



Caution Ensure to complete the SC replacement within 3 minutes as removing an SC also removes the fan modules. We recommend that you remove or replace the SC and fan modules as a single unit to save the replacement time.

Procedure

Step 1 If you are replacing an SC, open the packaging for the new module and inspect it for damage. If the SC is damaged, contact your customer service representative and stop this replacement process until you have an undamaged SC to install.

Step 2 Remove the SC that you are replacing by following these steps:

- a) Loosen the captive screws on both sides of the SC. Wait for the Status LED to go in Off state.
- b) Rotate the handles outwards until they stop (see Callout 2 in the following figure).
- c) Use the ejector handles to pull the module a couple of inches (about 5 cm) out of the slot until it stops.

Note Hold the front of the SC with one hand and place your other hand under the SC to support its weight.

Figure 112: Remove Switch Card from Chassis

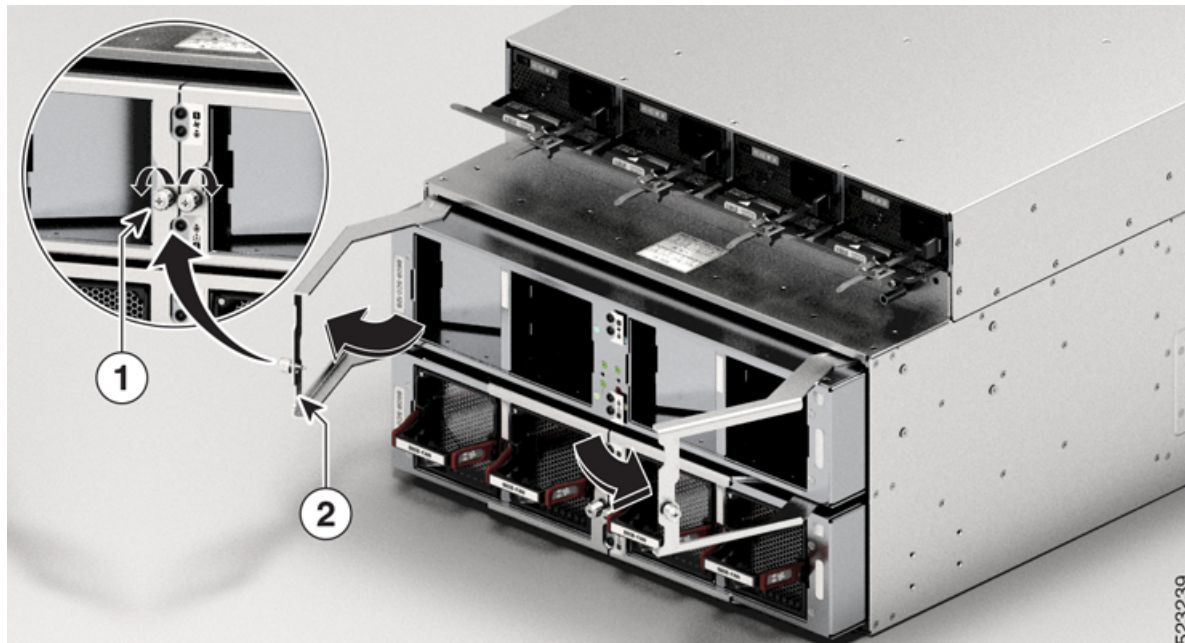

1	Two captive screws (one on each handle)	2	Rotate both ejector handles to the front of the module. Pull on both handles to partially remove the SC from the chassis
---	---	---	--

Figure 113: Pull Switch Card from Chassis

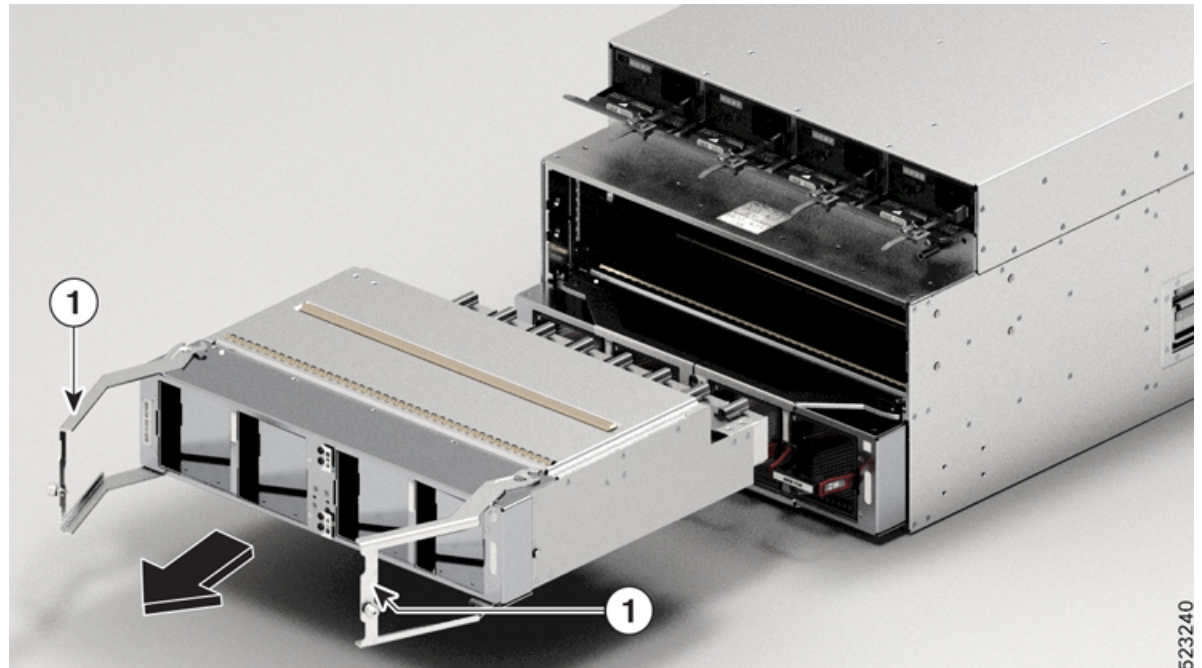

1	Pull on both ejector handles to partially remove the SC from the chassis
---	--

- d) Close the ejector handles and tighten the captive screws to 9.7 in-lbs (1.09 N-m) of torque.
- e) Pull the module out of the slot.

Caution Use caution when handling the SC. A fully loaded SC (with fans) weighs 27 lbs (12.25 kg). An empty SC (no fans) weighs 21.8 lbs (9.89 kg).

- f) Place the SC on an antistatic surface or in an antistatic bag.

Install a Switch Card



Caution Ensure to complete the Switch Card replacement within 3 minutes as removing an SC also removes the fan modules.

We recommend that you remove or replace the SC and fan modules as a single unit to save the replacement time.

Procedure

- Step 1** Unscrew the two captive screws (one on each ejector handle) and rotate the ejector handles until it stops.
- Step 2** Slide the SC into the slot until it stops.

Step 3 Close the ejector levers.

Attention Ensure to close both the ejector levers at the same time so that the SC sits properly in the SC slot.

Step 4 Tighten the captive screw on each side of the SC to 9.7 in-lbs (1.09 N-m) of torque.

Step 5 Reinstall the fan modules into the SC.

Refer to installing the fan tray procedure: [Replace a Fan Module, on page 131](#)

Note Tighten the captive screws on the SC within 10 seconds. If you can't replace an SC within three minutes, we recommend that you leave the SC in the chassis until you are ready to replace it.

Replace a Fan Spinner

The following sections describe how to remove or install a Fan Spinner:

Remove a Fan Spinner

- You must wear an electrostatic discharge (ESD) wrist strap or other ESD protective device while handling modules.
- Prepare an antistatic surface or packing materials for each module that you remove from the chassis.



Caution Ensure to complete the Fan Spinner replacement within 3 minutes as removing a Fan Spinner also removes the fan modules.

We recommend that you remove or replace the Fan Spinner and fan modules as a single unit to save the replacement time.

1. If you are replacing a Fan Spinner, open the packaging for the new module and inspect it for damage.



Note If the Fan Spinner is damaged, contact your customer service representative and stop this replacement process until you have an undamaged Fan Spinner to install.

2. Remove the Fan Spinner that you are replacing by following these steps:
 - a. Loosen the captive screws on both sides of the Fan Spinner.
 - b. Rotate the handles outwards until they stop (see Callout 2 in the following figure).
 - c. Use the ejector handles to pull the module a couple of inches (about 5 cm) out of the slot until it stops.



Note Hold the front of the Fan Spinner with one hand and place your other hand under the Fan Spinner to support its weight.

Figure 114: Remove Fan Spinner from Chassis

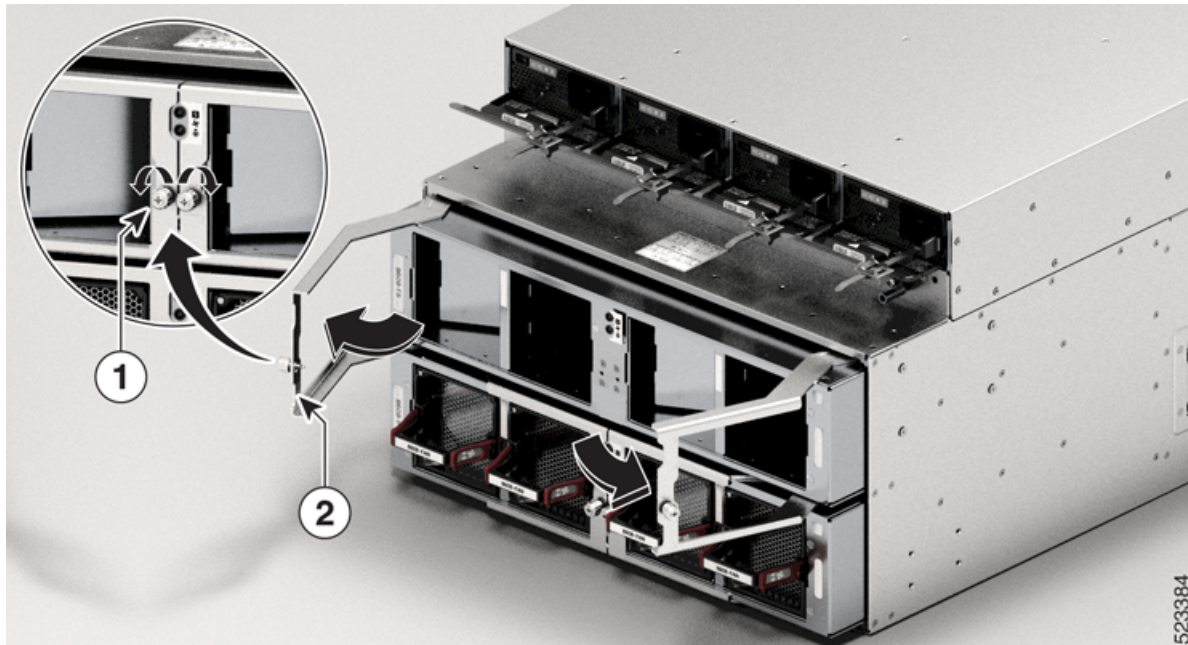

1	Two captive screws (one on each handle)	2	Rotate both ejector handles to the front of the module. Pull on both handles to partially remove the Fan Spinner from the chassis
---	---	---	---

Figure 115: Pull Fan Spinner from Chassis

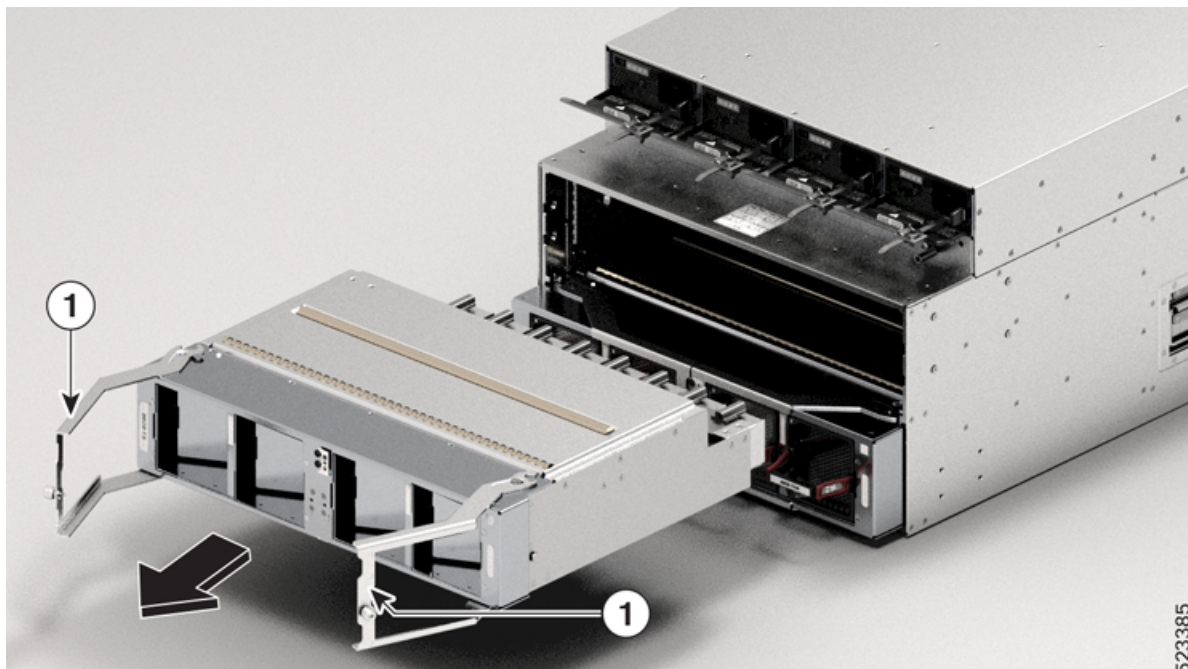

1	Pull on both ejector handles to partially remove the Fan Spinner from the chassis
---	---

- d. Close the ejector handles and tighten the captive screws.
- e. Pull the module out of the slot.



Caution Use caution when handling the Fan Spinner. A fully loaded Fan Spinner (with fans) weighs 17.5 lbs (7.94 kg). An empty Fan Spinner (no fans) weighs 12.3 lbs (5.58 kg).

- f. Place the Fan Spinner on an antistatic surface or in an antistatic bag.

Install a Fan Spinner



Caution Ensure to complete the Fan Spinner replacement within 3 minutes as removing a Fan Spinner also removes the fan modules.

We recommend that you remove or replace the Fan Spinner and fan modules as a single unit to save the replacement time.

1. Unscrew the two captive screws (one on each ejector handle) and rotate the ejector handles until it stops.
2. Slide the Fan Spinner into the slot until it stops.
3. Close the ejector levers.



Attention Ensure to close both the ejector levers at the same time so that the Fan Spinner sits properly in the slot.

4. Tighten the captive screw on each side of the Fan Spinner to 9.7 in-lbs (1.09 N-m) of torque.
5. Reinstall the fan modules into the Fan Spinner.

Refer to installing the fan tray procedure: [Replace a Fan Module, on page 131](#)



Note Tighten the captive screws on the Fan Spinner within 10 seconds. If you can't replace an Fan Spinner within three minutes, we recommend that you leave the Fan Spinner in the chassis until you are ready to replace it.

Replace a Fan Module

The Cisco 8608 router uses eight fan modules (8608-FAN) but it can operate with seven fan modules while you replace one. When you remove one fan module, the other fan modules speed up their fans to maintain the designed airflow.

The fan module is designed to be removed and replaced while the system is operating without presenting an electrical hazard or damage to the system. Please keep the replacement fan modules ready prior to attempting this task.



Note To ensure adequate airflow and prevent overheating, do not operate the router with seven fan modules for more than 10 minutes.

If you cannot replace a fan module within three minutes, we recommend that you leave it in the chassis until you are ready to replace it.



Caution Never remove two fan modules at a time during operation. The router allows up to two minutes of operations before shutting down unless you replace the missing fan module within that time. If the router senses an over temperature condition when multiple fan modules are removed, the shutdown can occur in fewer than two minutes.



Warning **Statement 1090**—Installation by Skilled Person

Only a skilled person should be allowed to install, replace, or service this equipment. See statement 1089 for the definition of a skilled person.

There are no serviceable parts inside. To avoid risk of electric shock, do not open.



Warning **Statement 1091**—Installation by an Instructed Person

Only an instructed person or skilled person should be allowed to install, replace, or service this equipment. See statement 1089 for the definition of an instructed or skilled person.

There are no serviceable parts inside. To avoid risk of electric shock, do not open.



Warning **Statement 1073**—No User-Serviceable Parts

There are no serviceable parts inside. To avoid risk of electric shock, do not open.



Warning **Statement 1029**—Blank Faceplates and Cover Panels

Blank faceplates and cover panels serve three important functions: they prevent exposure to hazardous voltages and currents inside the chassis; they contain electromagnetic interference (EMI) that might disrupt other equipment; and they direct the flow of cooling air through the chassis. Do not operate the system unless all cards, faceplates, front covers, and rear covers are in place.



Warning **Statement 1034**—Backplane Voltage

Hazardous voltage or energy is present on the backplane when the system is operating. Use caution when servicing

**Warning Statement 1051—Laser Radiation**

Invisible laser radiation may be emitted from disconnected fibers or connectors. Do not stare into beams or view directly with optical instruments.

Figure 116: Cisco 8608 Router - Replace Fans

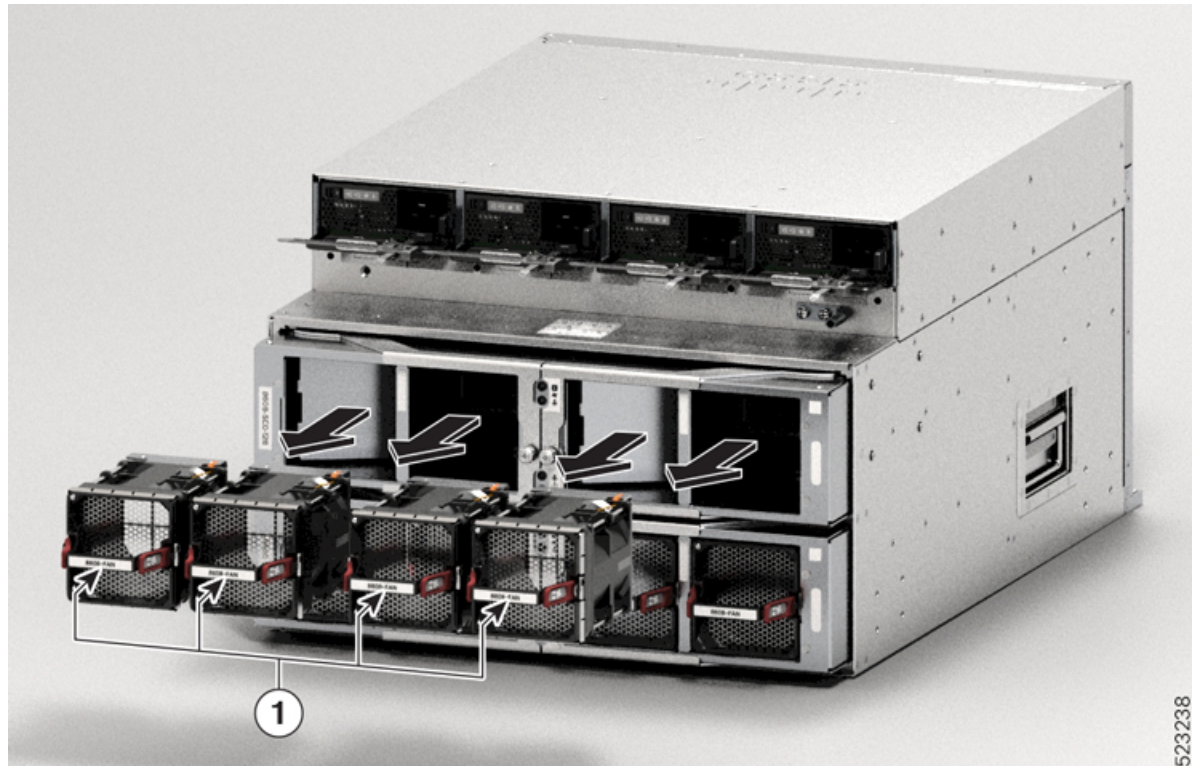

To replace a fan tray, you must perform the following functions:

1. Press the latch to remove the fan to be replaced.
2. Hold the fan module with the LED and PID label at the top.
3. Align the fan module to the open fan slot in the chassis and press the module all the way into the slot until the front of the fan module touches the chassis.

Ensure that the thumbscrew on the fan module is aligned with the screw hole in the chassis.

4. If the chassis is powered on, listen for the fans. You should immediately hear them operating. If you do not hear them, ensure that the fan module is inserted completely in the chassis.
5. Verify that the fan module LED is green. If the LED is not green, one or more fans are faulty. If this situation occurs, contact your customer service representative for replacement parts.

Replace Power Modules

The following sections describe how to remove or install power modules:

Remove an AC Power Supply Unit

To remove an AC Power Supply Unit (PSU), follow the steps described here.

Before you begin



Warning **Statement 1073**—No User-Serviceable Parts

There are no serviceable parts inside. To avoid risk of electric shock, do not open.

Procedure

Step 1 Set the AC-input power supply rocker switch to the OFF (0) position

Figure 117: AC Power Supply Switch Position - PSU3.2KW-ACPI

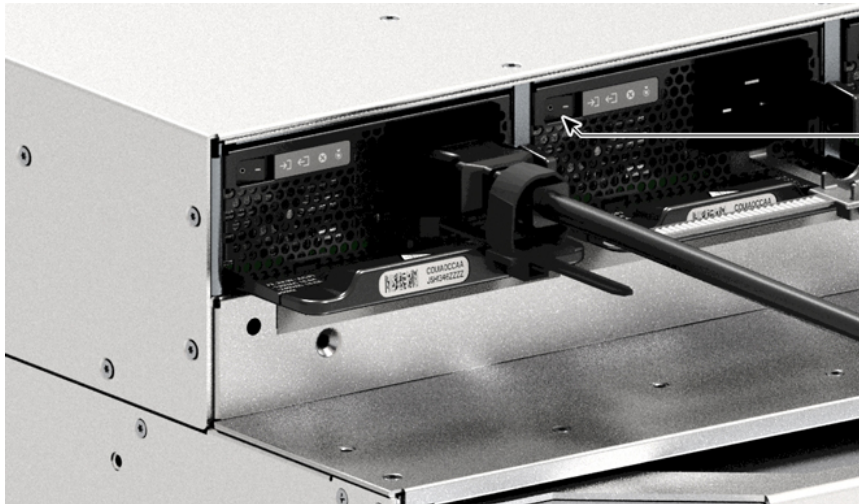

523363

Figure 118: AC Power Supply Switch Position - PSU4.3KW-HVPI



523989

1	Power supply in the OFF (0) position
---	--------------------------------------

Step 2 Loosen and remove the retainer strip that is around the power cord.

See [Power Cord Retainer Mechanism, on page 55](#).

Step 3 Remove the power cord from AC-in receptacle.

Step 4 Press the release latch of the PSU inward.

Figure 119: Release PSU Latch - PSU3.2KW-ACPI

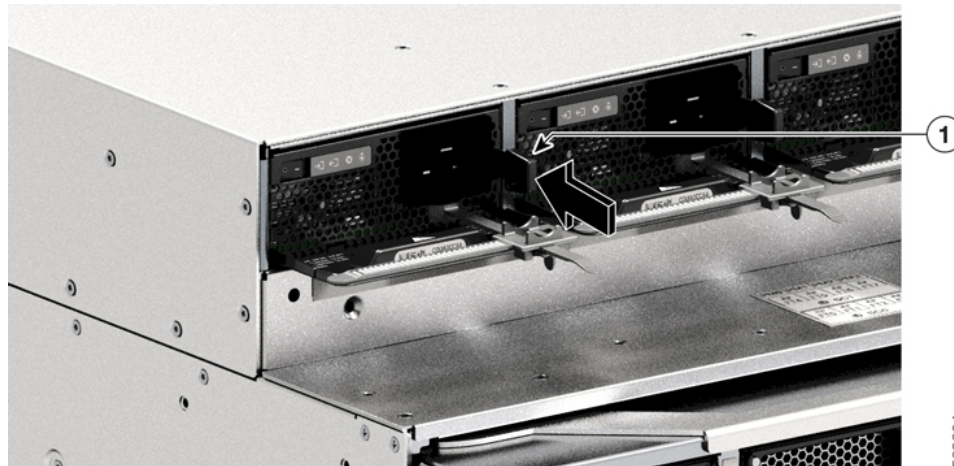

523364

Figure 120: Release PSU Latch - PSU4.3KW-HVPI

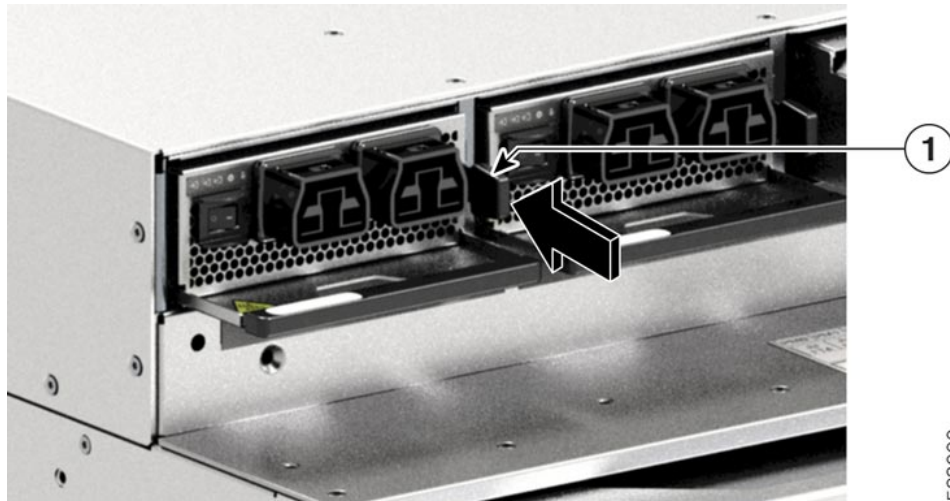

523990

1	Release latch, which should be pressed inwards
---	--

Step 5 Grasp the PSU with one hand; place your other hand underneath to support the bottom of the power supply. Slide it out of the bay completely.

Figure 121: Slide the PSU Out - PSU3.2KW-ACPI



523365

Figure 122: Slide the PSU Out - PSU4.3KW-HVPI

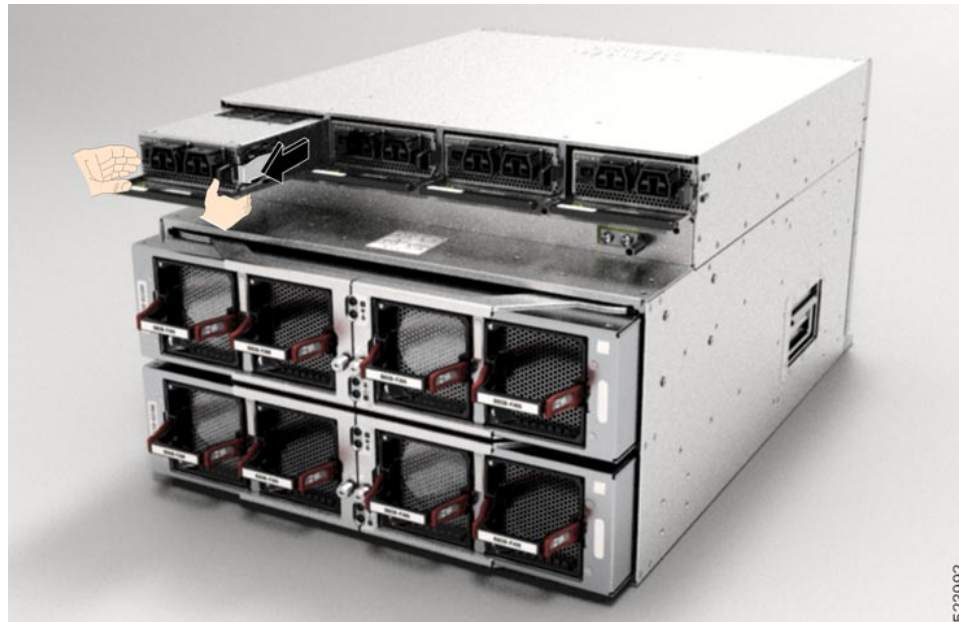

Caution Do not leave any power supply slot open for any amount of time while the system is powered up. Prior to inserting a new PSU, for instance, when replacing the unit, ensure there are no foreign, conductive or other objects, or debris in the slot.

Warning Statement 1028—More Than One Power Supply

This unit might have more than one power supply connection. To reduce risk of electric shock, remove all connections to de-energize the unit.

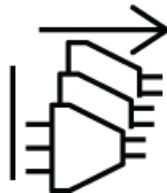

What to do next

Set the power supply aside and proceed with installing the new or replacement PSU. For more information, see [Connect AC Power to the Chassis, on page 50](#).

Remove a DC Power Supply Unit

When removing a DC Power Supply Unit (PSU), you will need access to the terminal block of the module to disconnect the DC-input wires. If the front panel of the chassis has limited access because of other interfering cables, consider removing the module from the chassis before disconnecting the DC-input wires. If you do have clear access to the terminal block, you can disconnect the DC-input wires and then remove the module from the chassis. In either case (whether you have access to the front panel or not), you must begin by

completing all the steps described in [Powering Down the DC-Input Power Supply](#). Proceed with the next task depending on your setup.

The procedures to disconnect DC-input wires and to remove the module from the chassis have been described in [Disconnect the DC-Input Wires](#), on page 138 and [Remove a DC Power Supply Unit from the Chassis](#), on page 140.

Power Down a DC Power Supply Unit

To power down a DC-input Power Supply Unit (PSU), follow the steps described here.

Before you begin



Warning **Statement 1073**—No User-Serviceable Parts

There are no serviceable parts inside. To avoid risk of electric shock, do not open.

Procedure

Step 1 Press the power button on the PSU for two seconds to turn it off. Check that the OUTPUT LED is off.

Figure 123: Power Off the PSU

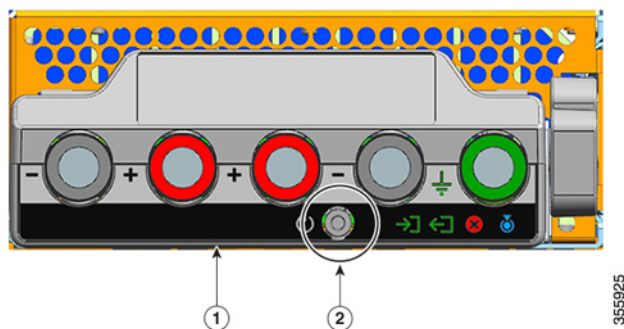

1	Front panel of the PSU3.2KW-DCPI	2	Power button
---	----------------------------------	---	--------------

Step 2 Locate the circuit breaker on the panel board that services the DC circuit, and switch the circuit breaker to the OFF position.

Step 3 Check that the INPUT LED on the PSU is off.

The FAIL LED is illuminated for two to three seconds after DC input is disconnected through a circuit breaker.

Disconnect the DC-Input Wires

To disconnect the DC-input wires, follow the steps described here.

Before you begin**Warning Statement 1073—No User-Serviceable Parts**

There are no serviceable parts inside. To avoid risk of electric shock, do not open.

Procedure

- Step 1** Using a number one Phillips screwdriver, loosen the captive installation screw on the terminal block cover and lift to open.

Figure 124: Open Terminal Block Cover



- Step 2** Using a nut driver, loosen the two nuts of one terminal slot at a time. After the lugs are removed, place the nuts back on the terminal posts and tighten.

The nut driver you are using must have at least a three-inch shaft, to clear the height of the terminal block cover and enable you to loosen or tighten the nuts in the terminal slots.

Disconnect the DC-input wires from the terminal block first, and disconnect the ground wire last.

Figure 125: Disconnect DC-input Wires

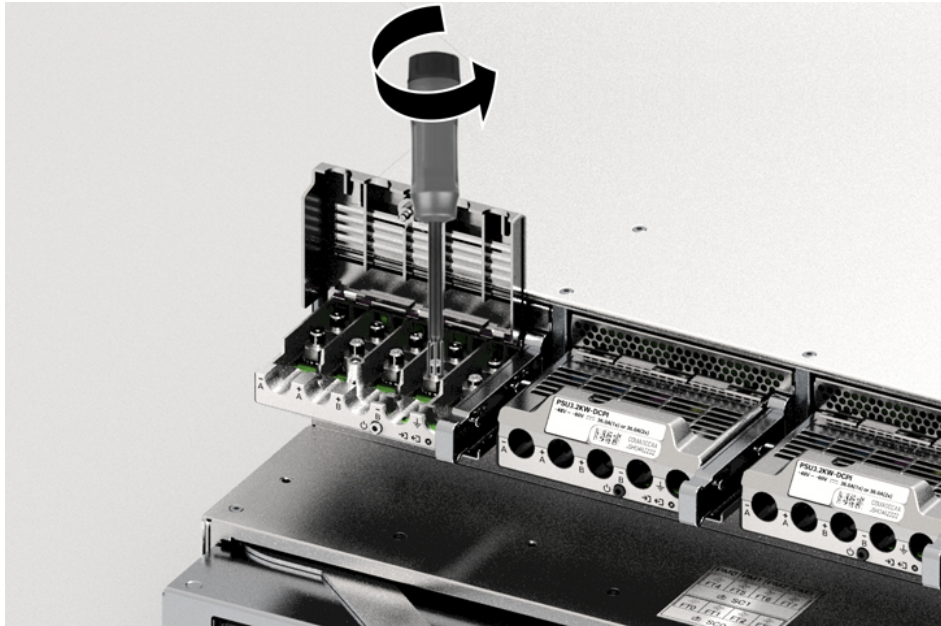

1 Terminal slots of the DC-input wires, which should be removed first	2 Terminal slots of the ground wire, which should be removed last
---	---

Step 3 Close the terminal block cover and finger-tighten the captive installation screw (approximately 0.25 Nm).

Remove a DC Power Supply Unit from the Chassis

To remove a DC-input Power Supply Unit (PSU) from the chassis, follow the steps described here.

Before you begin



Warning **Statement 1073**—No User-Serviceable Parts

There are no serviceable parts inside. To avoid risk of electric shock, do not open.

Procedure

Step 1 Pull out the latch on the module, to unlock it.

Figure 126: Unlock the Module

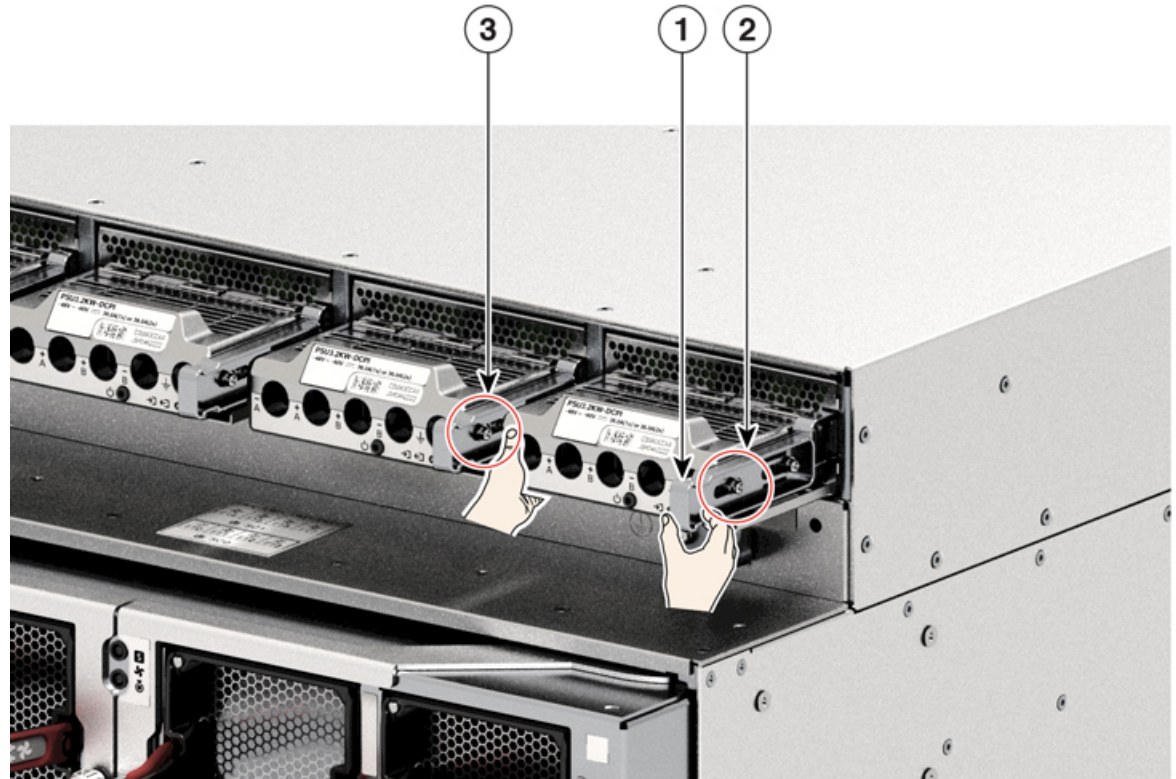

523390

1	Release latch to be pulled out (towards yourself)	3	Comparative location of the nut on a module where the release latch has not been pulled out.
2	Location of the nut on the side when the release latch has been pulled	-	-

Step 2 Grasp the terminal block with one hand and place your other hand underneath as you slide the PSU out of the bay.

Figure 127: Pull the DC PSU Out

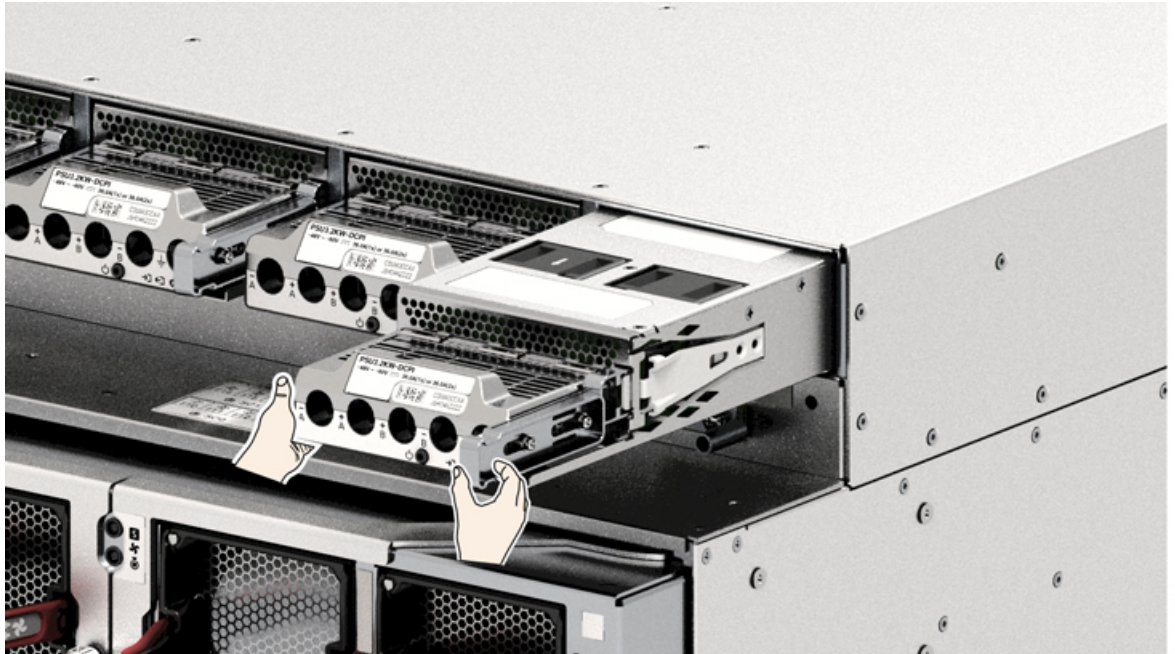

523391

Step 3 Install another power supply module. For information on the installation, see [Install a DC Power Supply Unit in the Chassis](#).

Caution Do not leave any power supply slot open for any amount of time while the system is powered up. Prior to inserting a new power supply unit, for instance, when you are replacing a unit, ensure there are no foreign, conductive, or other objects, or debris in the slot.



CHAPTER 7

LEDs

You can perform the following check on LEDs that assist you with the troubleshooting process:

- [Chassis LED, on page 143](#)
- [Route Processor LEDs, on page 143](#)
- [MPA LEDs, on page 147](#)
- [Power Supply LED, on page 149](#)
- [Fan Tray LED, on page 154](#)
- [Switch Card LED, on page 155](#)
- [Fan Spinner LEDs, on page 157](#)

Chassis LED

This section describes the chassis LED and its status.

Table 13: Chassis LED Descriptions

LED	Color	Status
	Flashing Blue	The operator has activated this LED to identify this chassis.
	Off	The operator has not activated this LED.

Route Processor LEDs

The Route Processor (RP) LEDs are located on the front of the chassis.

Figure 128: RP LEDs - Cisco 8608

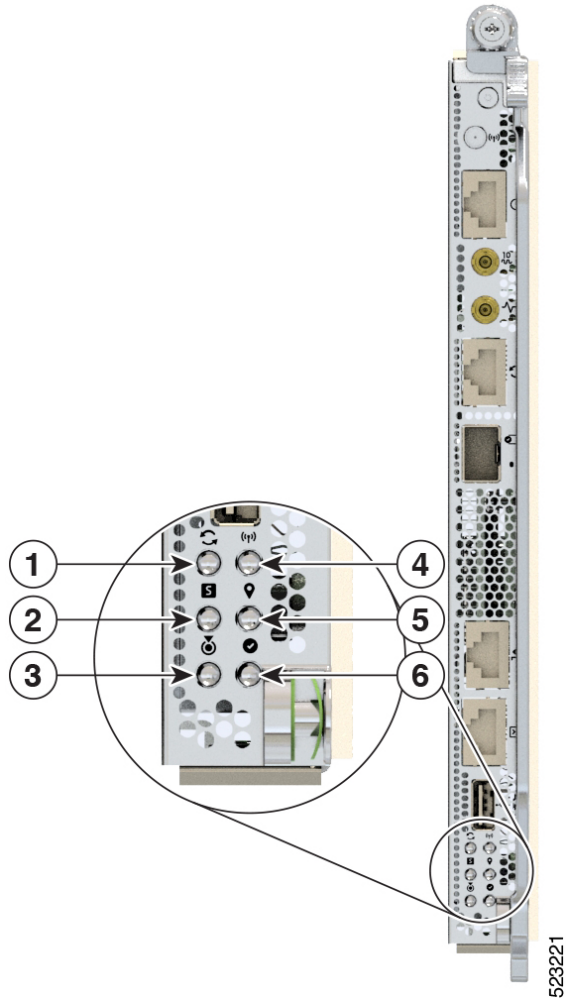

523221

1	Sync
2	Status
3	Attention
4	Management Activity
5	GPS
6	Active

Table 14: RP LED Descriptions

LED	Color	Status
Attention	Flashing Blue	The operator has activated this LED to identify this chassis.
	Solid Blue	During bootup, if secure boot validation check fails on BIOS, it causes the router to halt the booting process. During run time, if secure JTAG detect tampering attempt to the CPU JTAG chain, then the router halts the CPU and sets the LED into this state. Note The router displays two LEDs. Solid Blue for Attention LED and Solid Red for Status LED.
	Off	The operator has not activated this LED.

LED	Color	Status
Status	Solid Amber	The module is in one of the following states: <ul style="list-style-type: none"> • Booting up • Shutting down • Power cycling • Installing image
	Solid Green	This module is operational with no issues.
	Flashing Green	Auto or Manual FPD upgrade is in-progress.
	Flashing Amber	The module has an active minor alarm.
	Flashing Red	The module has an active major or critical alarm.
	Solid Red	The module is in one of the following states: <ul style="list-style-type: none"> • Power-up failure that prevents the CPU from booting. • During bootup, if secure boot validation check fails on BIOS, it causes the router to halt the booting process. During run time, if secure JTAG detect tampering attempt to the CPU JTAG chain, then the router halts the CPU and sets the LED into this state. <p>Note The router displays two LEDs. Solid Blue for Attention LED and Solid Red for Status LED.</p>
Off	The module is in one of the following states: <ul style="list-style-type: none"> • The module is in shutdown state by using either shutdown location <i>location</i> command in the EXEC mode or by using the hw-module shutdown location <i>location</i> command in the Config mode. • While the card is in running state, the ejector lever is opened that triggers the auto-shutdown operation for the module. • The module is placed in shutdown state by the software due to a hardware fault or a critical alarm condition. <p>Note While in this state, the module can be safely removed from the router.</p>	

LED	Color	Status
Active	Solid Green	This module is operational and in active redundancy state
	Off	The module is in one of the following states: <ul style="list-style-type: none"> • The redundancy state, active or standby, is not decided yet. • This module is in the standby redundancy state.
Management Link	Green	The management port is linked up.
	Off	The management port is not linked up.
Management Activity	Flashing Green	The management port is transmitting or receiving.
	Off	The management port is not transmitting or receiving.
1588 Port Link	Green	The 1588 port is linked up.
	Off	The 1588 port is not linked up.
1588 Port Activity	Flashing Green	The 1588 port is transmitting or receiving.
	Off	The 1588 port is not transmitting or receiving.
Sync	Green	The frequency, time, and phase are synchronized with an external interface (BITS, GPS, Recovered RX Clock).
	Amber	The time core is in free-run or holdover mode.
	Off (Default after reset)	The time core clock synchronization is disabled. This is the default state after a reset.
GPS	Green	The GPS interface is provisioned and ports are turned on. Time of day (ToD), 1 packet per second (1PPS), and 10MHz are all valid.
	Off (Default after reset)	Either the interface is not provisioned or the ports are not turned on. ToD, 1PPS, and 10MHz are not valid.

MPA LEDs

The Status LED and the Attention LED are located on the bottom of the MPA. The Link LEDs for each port are located on the right-side of the MPA, next to the ejector lever.

Figure 129: MPA LEDs

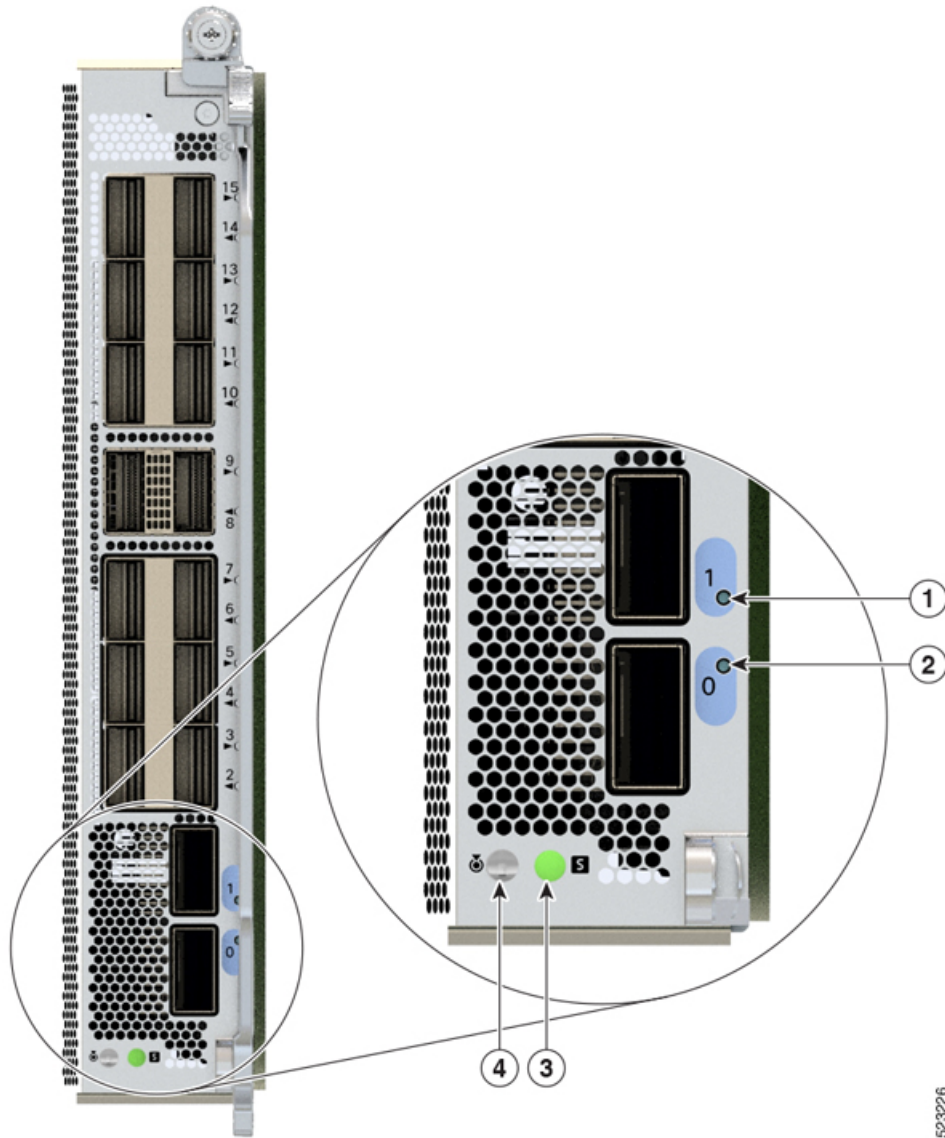

523226

1	Link (Port 1)
2	Link (Port 0)
3	Status
4	Attention

Table 15: MPA LED Descriptions

LED	Color	Status
Attention	Flashing Blue	The operator has activated this LED to identify this module in the chassis.
	Off	This module is not identified by the operator.
Status	Solid Amber	The module is in one of the following states: <ul style="list-style-type: none"> • Booting up • Shutting down • Power cycling
	Solid Green	The module is operational with no issues.
	Solid Red	The module has failed to power-up
	Flashing Green	Auto or manual FPD upgrade is in-progress.
	Flashing Red	The module has an active major or critical alarm.
	Flashing Amber	The module has an active minor alarm.
	Off	The module is in one of the following states: <ul style="list-style-type: none"> • The module is in shutdown state by using either shutdown location location command in the EXEC mode or by using the hw-module shutdown location location command in the Config mode. • While the card is in running state, the ejector lever is opened that triggers the auto-shutdown operation for the module. • The module is placed in shutdown state by the software due to a hardware fault or a critical alarm condition. <p>Note While in this state, the module can be safely removed from the router.</p>
Port (for each port)	Green	The port is administratively enabled and the link is up.
	Amber	The port is administratively enabled and the link is down.
	Off	The port is administratively shut down.

Power Supply LED

For the PSU3.2KW-ACPI and PSU4.3KW-HVPI PSU, the power module LEDs are located on the upper-left portion of the module. For the PSU3.2KW-DCPI PSU, the power module LEDs are located on the lower-right portion of the module.



Note The following figure displays LEDs for an AC PSU.

Figure 130: Power Supply LEDs - PSU3.2KW-ACPI

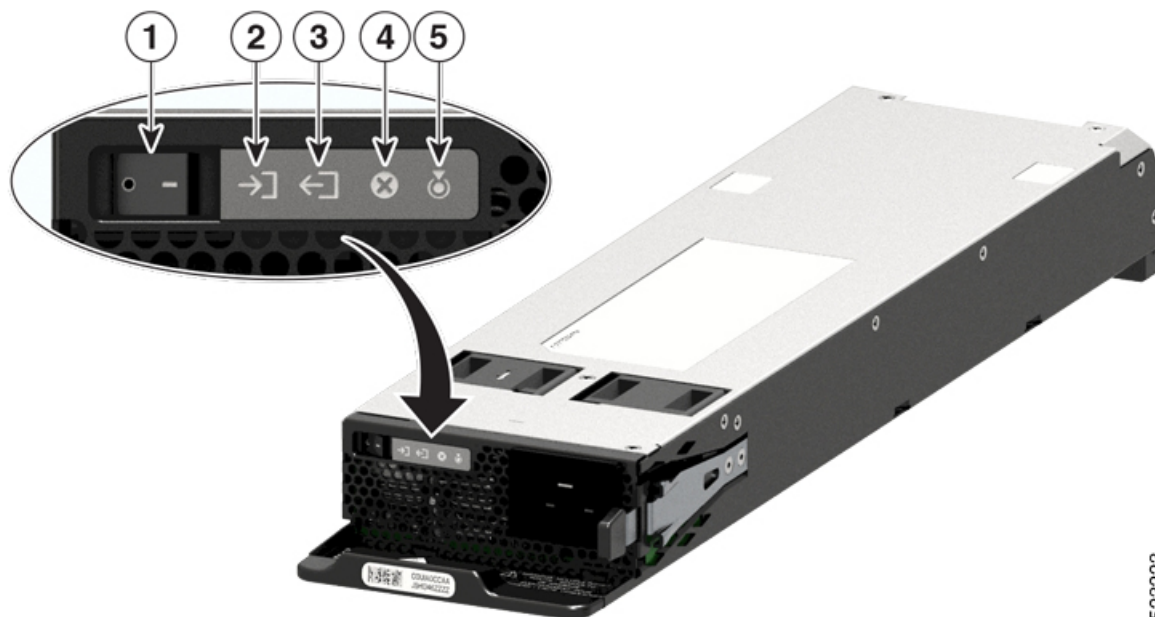

523223

Table 16: Power Supply LEDs Descriptions - PSU3.2KW-ACPI

1	On/Off Switch
2	Input Status
3	Output Status
4	Fault
5	Attention

Table 17: Power Supply LED Status Description - PSU3.2KW-ACPI

LED	Color	Status
Attention	Blinking Blue	The operator has configured this LED to identify this PSU.
	Off	This device is not identified or configured.

LED	Color	Status
Input Status	Green	Both inlet power present Note AC input voltage is 70 V minimum. AC PSU is single-input supply. DC input voltage is -40 V minimum. DC PSU is dual-input supply.
	Blinking Green	The module is in one of the following states: <ul style="list-style-type: none"> • Only one input power present • Hot unplugged Note AC input voltage is between 70 V and 85 V. DC input voltage is: <ul style="list-style-type: none"> • between -27 V and -37 V • greater than -75 V and less than -77 V Note In DC dual-inputs mode, the absence of LED light indicates that DC input(s) are less than -26 V or greater than 77 V. For a DC input voltage between -27 V and -37 V, or greater than -75 V and less than -77 V, the IN LED flashes on/off (0.5 sec ON / 0.5 sec OFF). In single-input mode, the IN LED flashes on/off to indicate an ON state.
	Off	The module is in one of the following states: <ul style="list-style-type: none"> • No input is present • Module firmware upgrade is in-progress Note AC input voltage is less than 70 V. DC input voltage is less than -26 V.
Output Status	Green	The module is in one of the following states: Output power is enabled
	Blinking Green	The module is in one of the following states: <ul style="list-style-type: none"> • Output is out of regulation. • In sleep mode (Not present in DC-60)
	Off	Firmware upgrade is in-progress.

LED	Color	Status
Fault	Red	The module has detected a fault within the power supply unit. Illuminates for 2-3 seconds after input is applied or disconnected through the front panel On/ Off switch (for AC-input power supplies) or On/ Off power button (for DC-input power supplies) or a circuit breaker. Note For DC input voltages that are greater than 77 VDC, this LED blinks on-off (0.5 sec ON / 0.5 sec OFF).
	Blinking Red	Module firmware upgrade is in-progress

Figure 131: Power Supply LEDs - PSU4.3KW-HVPI

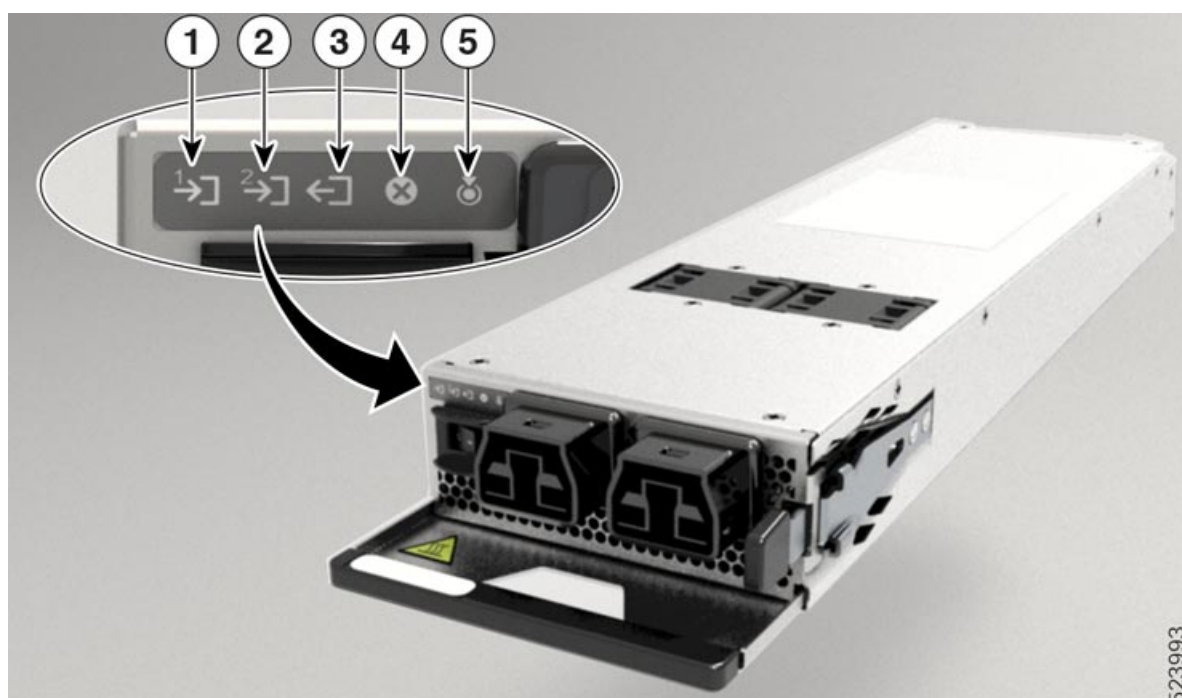

Table 18: Power Supply LEDs Descriptions - PSU4.3KW-HVPI

1	Input Status (Feed A)
2	Input Status (Feed B)
3	Output Status
4	Fault
5	Attention

Table 19: Power Supply LED Status Description - PSU4.3KW-HVPI

LED	Color	Status
Attention	Blinking Blue	The operator has configured this LED to identify this PSU.
	Off	The operator has not configured this LED.
Input Status	Green	Both inlet power present Note The PSUs shall operate within specification from 85V-305V AC or 192-400V DC continuously.
	Blinking Green	The module is in one of the following states: <ul style="list-style-type: none"> • Feed A or Feed B input power present Note AC input voltage is between 180V AC and 305V AC. DC input voltage is between 192V DC and 400V DC
	Off	The module is in one of the following states: <ul style="list-style-type: none"> • No input is present • Module firmware upgrade is in-progress Note AC input voltage is less than 180 V. DC input voltage is less than 192 V.
Output Status	Green	The module is in one of the following states: Output power is enabled
	Blinking Green	The module is in one of the following states: <ul style="list-style-type: none"> • Output is out of range.
	Off	The module is in one of the following states: <ul style="list-style-type: none"> • Firmware upgrade is in-progress. • Power tray switch is in Off position.

LED	Color	Status
Fault	Red	The module has detected a fault within the power supply unit. Illuminates for 2-3 seconds after the PSU is connected or disconnected through the front panel On/ Off switch (for AC-input power supplies) or On/ Off power button (for DC-input power supplies) or a circuit breaker. Note For DC input voltages that are greater than 400 VDC, this LED blinks on-off (0.5 sec ON / 0.5 sec OFF).
	Blinking Red	Module firmware upgrade is in-progress

Fan Tray LED

The fan tray LED is located on the top left portion of the fan tray.

Figure 132: Fan Tray LED

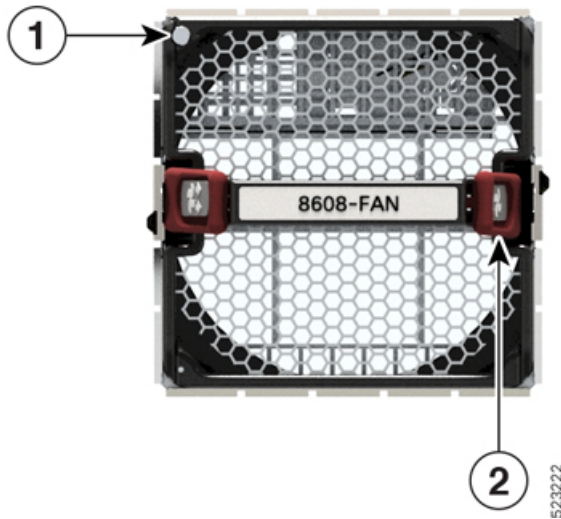

1	Attention or Status
2	Latch

Table 20: Fan Tray LED Descriptions

LED	Color	Status
Attention or Status	Green	The fan is operational, fan speed (RPM) is within normal range.
	Flashing Amber	The module is in one of the following states: <ul style="list-style-type: none"> Fan speed (RPM) is outside normal range for one or more fans. The module has a minor, major, or critical alarm.
	Flashing Blue	The module is identified or activated.
	Off	The module is not receiving power.

Switch Card LED

This section describes the LEDs and their status for Switch Card (SC) and Fan Board.

Figure 133: Switch Card LEDs

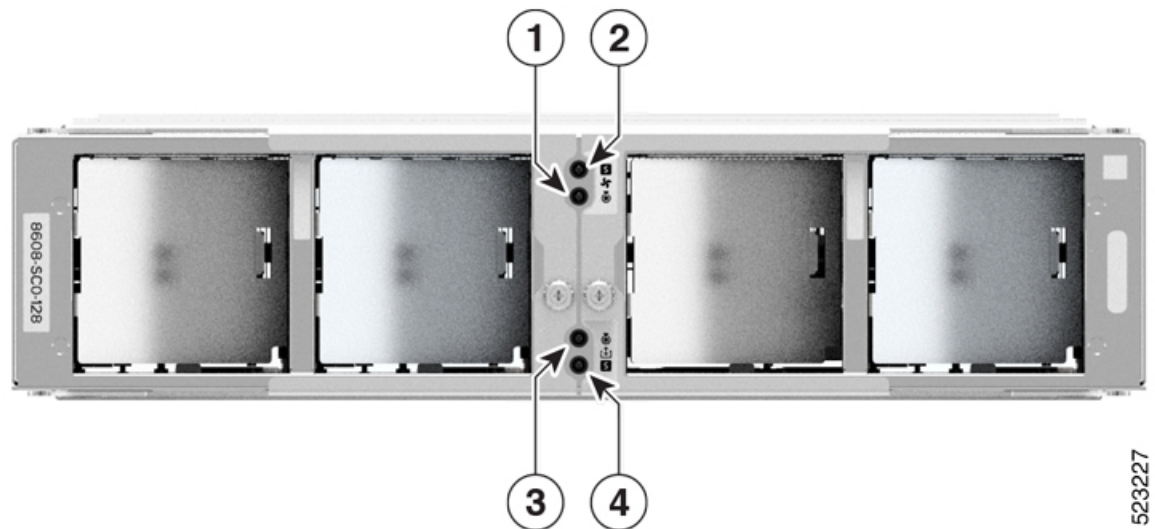

1	Fan Board Attention
2	Fan Board Status
3	Switch Card Attention
4	Switch Card Status

Table 21: Fan Board LED Descriptions

LED	Color	Status
Fan Board Attention	Flashing Blue	The operator has activated this LED to identify this module in the chassis.
	Off	This module is not being identified.
Fan Board Status	Solid Amber	The module is in one of the following states: <ul style="list-style-type: none"> • The module is powered on. • Graceful chassis reload, shutdown, or reimage
	Solid Green	This module is operational with no issues.
	Flashing Green	Auto or Manual FPD upgrade is in-progress.
	Flashing Amber	The module has an active minor alarm.
	Flashing Red	The module has major or critical alarms.



Note The Fan Board is hosted inside an SC. Fan Board controls the fan trays that are installed in the four fan tray slots. The fan tray slots are located in the front panel of the SC.

Table 22: Switch Card LED Descriptions

LED	Color	Status
Switch Card Attention	Flashing Blue	The operator has activated this LED to identify this module in the chassis.
	Off	This module is not being identified.

LED	Color	Status
Switch Card Status	Solid Amber	The module is in one of the following states: <ul style="list-style-type: none"> • The module is powered on. • Graceful chassis reload, shutdown, or reimage
	Solid Green	This module is operational with no issues.
	Solid Red	Power-up failure that prevents the card from powering up.
	Flashing Green	Auto or manual FPD upgrade is in-progress.
	Flashing Amber	The module has an active minor alarm.
	Flashing Red	The module has major or critical alarms.
	Off	<p>The module is in one of the following states:</p> <ul style="list-style-type: none"> • The module is in shutdown state by using either shutdown location location command in the EXEC mode or by using the hw-module shutdown location location command in the Config mode. • While the card is in running state, the ejector lever is opened that triggers the auto-shutdown operation for the module. • The module is placed in shutdown state by the software due to a hardware fault or a critical alarm condition. <p>Note While in this state, the module can be safely removed from the router.</p>

Fan Spinner LEDs

This section describes the Fan Spinner LEDs and their status.

These LEDs are for the fan board that controls the fan trays inserted in the four fan tray slots.

Figure 134: Fan Spinner LEDs

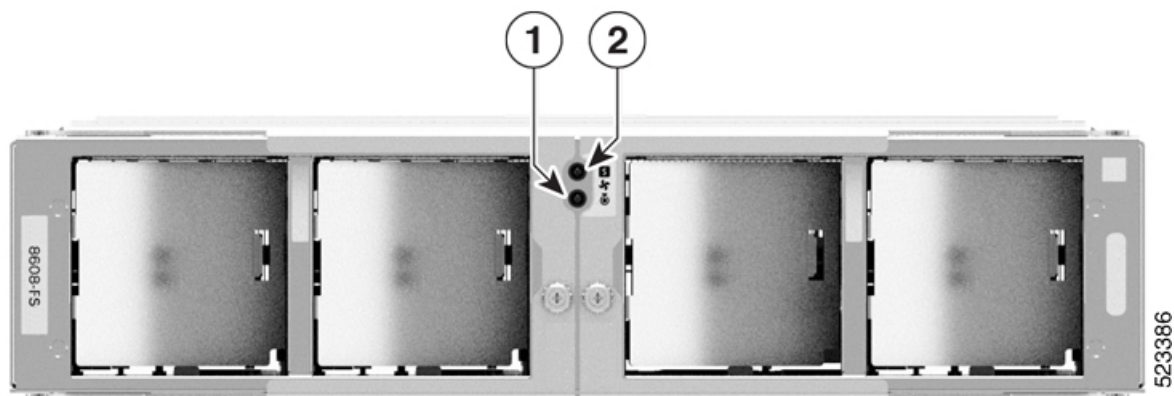

1	Fan Spinner Attention
2	Fan Spinner Status

Table 23: Fan Spinner LED Descriptions

LED	Color	Status
Fan Spinner Attention	Flashing Blue	The operator has activated this LED to identify this module in the chassis.
	Off	This module is not being identified.
Fan Spinner Status	Solid Amber	The module is in one of the following states: <ul style="list-style-type: none"> • The module is powered on. • Graceful chassis reload, shutdown, or reimage
	Solid Green	This module is operational with no issues.
	Flashing Green	Auto or manual FPD upgrade is in-progress.
	Flashing Amber	The module has an active minor alarm.
	Flashing Red	The module has major or critical alarms.