



## **IP Addressing: DHCP Configuration Guide, Cisco IOS XE Fuji 16.9.x**

### **Americas Headquarters**

Cisco Systems, Inc.  
170 West Tasman Drive  
San Jose, CA 95134-1706  
USA  
<http://www.cisco.com>  
Tel: 408 526-4000  
800 553-NETS (6387)  
Fax: 408 527-0883

THE SPECIFICATIONS AND INFORMATION REGARDING THE PRODUCTS IN THIS MANUAL ARE SUBJECT TO CHANGE WITHOUT NOTICE. ALL STATEMENTS, INFORMATION, AND RECOMMENDATIONS IN THIS MANUAL ARE BELIEVED TO BE ACCURATE BUT ARE PRESENTED WITHOUT WARRANTY OF ANY KIND, EXPRESS OR IMPLIED. USERS MUST TAKE FULL RESPONSIBILITY FOR THEIR APPLICATION OF ANY PRODUCTS.

THE SOFTWARE LICENSE AND LIMITED WARRANTY FOR THE ACCOMPANYING PRODUCT ARE SET FORTH IN THE INFORMATION PACKET THAT SHIPPED WITH THE PRODUCT AND ARE INCORPORATED HEREIN BY THIS REFERENCE. IF YOU ARE UNABLE TO LOCATE THE SOFTWARE LICENSE OR LIMITED WARRANTY, CONTACT YOUR CISCO REPRESENTATIVE FOR A COPY.

The Cisco implementation of TCP header compression is an adaptation of a program developed by the University of California, Berkeley (UCB) as part of UCB's public domain version of the UNIX operating system. All rights reserved. Copyright © 1981, Regents of the University of California.

NOTWITHSTANDING ANY OTHER WARRANTY HEREIN, ALL DOCUMENT FILES AND SOFTWARE OF THESE SUPPLIERS ARE PROVIDED "AS IS" WITH ALL FAULTS. CISCO AND THE ABOVE-NAMED SUPPLIERS DISCLAIM ALL WARRANTIES, EXPRESSED OR IMPLIED, INCLUDING, WITHOUT LIMITATION, THOSE OF MERCHANTABILITY, FITNESS FOR A PARTICULAR PURPOSE AND NON-INFRINGEMENT OR ARISING FROM A COURSE OF DEALING, USAGE, OR TRADE PRACTICE.

IN NO EVENT SHALL CISCO OR ITS SUPPLIERS BE LIABLE FOR ANY INDIRECT, SPECIAL, CONSEQUENTIAL, OR INCIDENTAL DAMAGES, INCLUDING, WITHOUT LIMITATION, LOST PROFITS OR LOSS OR DAMAGE TO DATA ARISING OUT OF THE USE OR INABILITY TO USE THIS MANUAL, EVEN IF CISCO OR ITS SUPPLIERS HAVE BEEN ADVISED OF THE POSSIBILITY OF SUCH DAMAGES.

Any Internet Protocol (IP) addresses and phone numbers used in this document are not intended to be actual addresses and phone numbers. Any examples, command display output, network topology diagrams, and other figures included in the document are shown for illustrative purposes only. Any use of actual IP addresses or phone numbers in illustrative content is unintentional and coincidental.

Cisco and the Cisco logo are trademarks or registered trademarks of Cisco and/or its affiliates in the U.S. and other countries. To view a list of Cisco trademarks, go to this URL: [www.cisco.com go trademarks](http://www.cisco.com/go/trademarks). Third-party trademarks mentioned are the property of their respective owners. The use of the word partner does not imply a partnership relationship between Cisco and any other company. (1721R)

© 2018 Cisco Systems, Inc. All rights reserved.



# CONTENTS

---

## CHAPTER 1

### Read Me First 1

---

## CHAPTER 2

### Configuring the Cisco IOS XE DHCP Server 3

Finding Feature Information 3

Prerequisites for Configuring the DHCP Server 3

Information About the Cisco IOS XE DHCP Server 4

Overview of the DHCP Server 4

Database Agents 4

Address Conflicts 4

DHCP Address Pool Conventions 4

DHCP Address Pool Selection 4

Address Bindings 5

Ping Packet Settings 5

DHCP Attribute Inheritance 6

DHCP Server Address Allocation Using Option 82 6

DHCP Address Allocation Using Option 82 Feature Design 7

Usage Scenario for DHCP Address Allocation Using Option 82 8

DHCP Class Capability 8

How to Configure the Cisco IOS XE DHCP Server 9

Configuring a DHCP Database Agent or Disabling Conflict Logging 9

Excluding IP Addresses 10

Configuring DHCP Address Pools 11

Configuring a DHCP Address Pool 11

Configuring a DHCP Address Pool with Secondary Subnets 15

Troubleshooting Tips 20

Verifying the DHCP Address Pool Configuration 20

Configuring Manual Bindings	22
Troubleshooting Tips	24
Configuring DHCP Static Mapping	24
Configuring the DHCP Server to Read a Static Mapping Text File	26
Customizing DHCP Server Operation	28
Configuring a Remote Device to Import DHCP Server Options from a Central DHCP Server	30
Configuring the Central DHCP Server to Update DHCP Options	30
Configuring the Remote Device to Import DHCP Options	31
Configuring DHCP Address Allocation Using Option 82	33
Restrictions for DHCP Address Allocation Using Option 82	33
Enabling Option 82 for DHCP Address Allocation	33
Troubleshooting Tips	34
Defining the DHCP Class and Relay Agent Information Patterns	34
Troubleshooting Tips	35
Defining the DHCP Address Pool	35
Configuring a Static Route with the Next-Hop Dynamically Obtained Through DHCP	36
Clearing DHCP Server Variables	38
Configuration Examples for the Cisco IOS XE DHCP Server	39
Example: Configuring the DHCP Database Agent	39
Example: Excluding IP Addresses	39
Example: Configuring DHCP Address Pools	39
Example: Configuring a DHCP Address Pool with Multiple Disjoint Subnets	41
Configuring Manual Bindings Example	43
Example: Configuring Static Mapping	43
Importing DHCP Options Example	43
Configuring DHCP Address Allocation Using Option 82 Example	44
Configuring a Static Route with the Next-Hop Dynamically Obtained Through DHCP Example	45
Additional References	46
Feature Information for the Cisco IOS XE DHCP Server	47
<b>CHAPTER 3</b>	<b>Configuring the DHCP Server On-Demand Address Pool Manager</b>
	49
Finding Feature Information	49
Prerequisites for Configuring the DHCP Server On-Demand Address Pool Manager	50

Restrictions for Configuring the DHCP Server On-Demand Address Pool Manager	50
Information About the DHCP Server On-Demand Address Pool Manager	50
ODAP Manager Operation	50
Subnet Allocation Server Operation	52
Benefits of Using ODAPs	53
How to Configure the DHCP Server On-Demand Address Pool Manager	53
Defining DHCP ODAPs as the Global Default Mechanism	53
Defining DHCP ODAPs on an Interface	54
Configuring the DHCP Pool as an ODAP	55
Configuring ODAPs to Obtain Subnets Through IPCP Negotiation	56
Configuring AAA	58
Configuring RADIUS	59
ODAP AAA Profile	59
Disabling ODAPs	61
Verifying ODAP Operation	62
Troubleshooting Tips	64
Monitoring and Maintaining the ODAP	64
How to Configure DHCP ODAP Subnet Allocation Server Support	66
Configuring a Global Pool on a Subnet Allocation Server	66
Global Subnet Pools	66
Configuring a VRF Subnet Pool on a Subnet Allocation Server	67
VRF Subnet Pools	67
Using a VPN ID to Configure a VRF Subnet Pool on a Subnet Allocation Server	69
VRF Pools and VPN IDs	69
Verifying the Subnet Allocation and DHCP Bindings	71
Troubleshooting the DHCP ODAP Subnet Allocation Server	72
Configuration Examples for DHCP Server On-Demand Address Pool Manager	73
Defining DHCP ODAPs as the Global Default Mechanism Example	73
Defining DHCP ODAPs on an Interface Example	73
Configuring the DHCP Pool as an ODAP Example	74
Configuring the DHCP Pool as an ODAP for Non-MPLS VPNs Example	76
Configuring AAA and RADIUS Example	77
Configuring a Global Pool for a Subnet Allocation Server Example	77
Configuring a VRF Pool for a Subnet Allocation Server Example	78

Using a VPN ID to Configure a VRF Pool on a Subnet Allocation Server Example 78

Verifying Local Configuration on a Subnet Allocation Server Example 78

Verifying Address Pool Allocation Information Example 79

Verifying Subnet Allocation and DHCP Bindings Example 79

Additional References 80

Feature Information for the DHCP Server On-Demand Address Pool Manager 81

Glossary 82

**CHAPTER 4**

**Configuring the Cisco IOS XE DHCP Relay Agent 85**

Finding Feature Information 85

Prerequisites for Configuring the DHCP Relay Agent 85

Information About the DHCP Relay Agent 86

    DHCP Relay Agent Overview 86

    Packet Forwarding Address 86

    Relay Agent Information Option 87

        Relay Agent Information Reforwarding Policy 88

    DHCP Relay Agent Support for MPLS VPNs 88

    DHCP Relay Support for Option 82 Encapsulation 90

How to Configure the DHCP Relay Agent 91

    Specifying the Packet Forwarding Address 91

    Configuring Relay Agent Information Option Support 92

    Configuring Relay Agent Information Option Support per Interface 94

    Configuring the Subscriber Identifier Suboption of the Relay Agent Information Option 96

    Configuring DHCP Relay Agent Support for MPLS VPNs 98

    Setting the Gateway Address of the DHCP Broadcast to a Secondary Address Using Smart Relay Agent Forwarding 99

    Configuring Relay Agent Information Option Encapsulation Support 100

    Troubleshooting the DHCP Relay Agent 101

Configuration Examples for the DHCP Relay Agent 102

    Example Configuring the DHCP Relay Agent and Relay Agent Information Option Support 102

    Example Configuring the DHCP Relay Agent and Relay Agent Information Option Support per Interface 103

    Example Configuring the Subscriber Identifier Suboption 103

    Example Configuring DHCP Relay Agent Support for MPLS VPNs 104

Example Configuring DHCP Smart Relay Agent Forwarding	104
Additional References	104
Technical Assistance	106
Feature Information for the Cisco IOS XE DHCP Relay Agent	106
Glossary	107

**CHAPTER 5****DHCP Relay Server ID Override and Link Selection Option 82 Suboptions 109**

Finding Feature Information	109
Restrictions for DHCP Relay Server ID Override and Link Selection Option 82 Suboptions	110
Information About DHCP Relay Server ID Override and Link Selection Option 82 Suboptions	110
Server ID Override Suboption	110
Link Selection Suboption	110
DHCP Relay Server ID Override and Link Selection Option 82 Suboptions Feature Design	110
How to Configure Support for the DHCP Relay Server ID Override and Link Selection Suboptions	112
Configuring the DHCP Relay Agent to Insert the DHCP Server ID Override and Link Selection Suboptions into Option 82	112
Configuration Examples for DHCP Relay Server ID Override and Link Selection Option 82 Suboptions	114
Example: DHCP Relay Server ID Override and Link Selection Option 82 Suboptions	114
Additional References for DHCP Relay Server ID Override and Link Selection Option 82 Suboptions	115
Feature Information for DHCP Relay Server ID Override and Link Selection Option 82 Suboptions	116
Glossary	116

**CHAPTER 6****DHCP Server RADIUS Proxy 117**

Finding Feature Information	117
Prerequisites for DHCP Server RADIUS Proxy	117
Restrictions for DHCP Server RADIUS Proxy	118
Information About DHCP Server RADIUS Proxy	118
DHCP Server RADIUS Proxy Overview	118
DHCP Server RADIUS Proxy Architecture	118
DHCP Server and RADIUS Translations	119
RADIUS Profiles for DHCP Server RADIUS Proxy	120

How to Configure DHCP Server RADIUS Proxy 121

- Configuring the DHCP Server for RADIUS-based Authorization 121
- Monitoring and Maintaining the DHCP Server 126

Configuration Examples for DHCP Server Radius Proxy 127

- Configuring the DHCP Server Example 127
- Configuring RADIUS Profiles Example 128

Additional References 128

Technical Assistance 129

Feature Information for DHCP Server RADIUS Proxy 129

Glossary 130

---

**CHAPTER 7**

**Configuring the Cisco IOS XE DHCP Client 131**

- Finding Feature Information 131
- Information About the DHCP Client 131
  - DHCP Client Operation 131
  - DHCP Client Overview 132
- How to Configure the DHCP Client 133
  - Configuring the DHCP Client 133
  - Troubleshooting Tips 134
- Configuration Examples for the DHCP Client 134
  - Configuring the DHCP Client Example 134
  - Customizing the DHCP Client Configuration Example 135
- Additional References 136
- Technical Assistance 137
- Feature Information for the Cisco IOS XE DHCP Client 137

---

**CHAPTER 8**

**Configuring DHCP Services for Accounting and Security 139**

- Finding Feature Information 139
- Prerequisites for Configuring DHCP Services for Accounting and Security 139
- Information About DHCP Services for Accounting and Security 140
  - DHCP Operation in Public Wireless LANs 140
  - Security Vulnerabilities in Public Wireless LANs 140
  - DHCP Services for Security and Accounting Overview 140
  - DHCP Lease Limits 141



How to Configure DHCP Services for Accounting and Security	141
Configuring AAA and RADIUS for DHCP Accounting	141
Troubleshooting Tips	143
Configuring DHCP Accounting	144
Verifying DHCP Accounting	145
Securing ARP Table Entries to DHCP Leases	146
Troubleshooting Tips	147
Configuring a DHCP Lease Limit to Control the Number of Subscribers on an Interface	147
Troubleshooting Tips	149
Configuration Examples for DHCP Services for Accounting and Security	149
Example: Configuring AAA and RADIUS for DHCP Accounting	149
Example: Configuring DHCP Accounting	150
Example: Verifying DHCP Accounting	150
Example: Configuring a DHCP Lease Limit	151
Additional References	151
Technical Assistance	152
Feature Information for DHCP Services for Accounting and Security	153

**CHAPTER 9**

<b>ISSU and SSO--DHCP High Availability Features</b>	<b>155</b>
Finding Feature Information	155
Prerequisites for DHCP High Availability	156
Restrictions for DHCP High Availability	156
Information About DHCP High Availability	156
ISSU	156
SSO	156
ISSU and SSO--DHCP Server	156
ISSU and SSO--DHCP Relay on Unnumbered Interface	157
ISSU and SSO--DHCP Proxy Client	158
ISSU and SSO--DHCP ODAP Client and Server	159
How to Configure DHCP High Availability	160
Configuration Examples for DHCP High Availability	160
Additional References	160
Feature Information for DHCP High Availability Features	162
Glossary	162

---

<b>CHAPTER 10</b>	<b>DHCPv6 Relay and Server - MPLS VPN Support</b>	<b>165</b>
	Finding Feature Information	165
	Information About DHCPv6 Relay and Server - MPLS VPN Support	165
	DHCPv6 Server and Relay—MPLS VPN Support	165
	How to Configure DHCPv6 Relay and Server - MPLS VPN Support	166
	Configuring a VRF-Aware Relay and Server for MPLS VPN Support	166
	Configuring a VRF-Aware Relay	166
	Configuring a VRF-Aware Server	167
	Configuration Examples for DHCPv6 Server - MPLS VPN Support	168
	Example: Configuring a VRF-Aware Relay	168
	Example: Configuring a VRF-Aware Server	168
	Additional References	169
	Feature Information for DHCPv6 Relay and Server - MPLS VPN Support	170

---

<b>CHAPTER 11</b>	<b>IPv6 Access Services: DHCPv6 Relay Agent</b>	<b>173</b>
	Finding Feature Information	173
	Information About IPv6 Access Services: DHCPv6 Relay Agent	173
	DHCPv6 Relay Agent	173
	DHCPv6 Relay Agent Notification for Prefix Delegation	175
	DHCPv6 Relay Options: Remote ID for Ethernet Interfaces	175
	DHCPv6 Relay Options: Reload Persistent Interface ID Option	176
	DHCPv6 Relay Chaining	176
	How to Configure IPv6 Access Services: DHCPv6 Relay Agent	176
	Configuring the DHCPv6 Relay Agent	176
	Configuration Examples for IPv6 Access Services: DHCPv6 Relay Agent	177
	Example: Configuring the DHCPv6 Relay Agent	177
	Additional References	178
	Feature Information for IPv6 Access Services: DHCPv6 Relay Agent	178

---

<b>CHAPTER 12</b>	<b>IPv6 Access Services: Stateless DHCPv6</b>	<b>181</b>
	Finding Feature Information	181
	Information About IPv6 Access Services: Stateless DHCPv6	181
	Information Refresh Server Option	181

SIP Server Options	182
SNTP Server Option	182
How to Configure IPv6 Access Services: Stateless DHCPv6	182
Configuring the Stateless DHCPv6 Function	182
Configuring the Stateless DHCPv6 Server	182
Configuring the Stateless DHCPv6 Client	184
Enabling Processing of Packets with Source Routing Header Options	184
Importing Stateless DHCPv6 Server Options	185
Configuration Examples for IPv6 Access Services: Stateless DHCPv6	189
Example: Configuring the Stateless DHCPv6 Function	189
Additional References	189
Feature Information for IPv6 Access Services: Stateless DHCPv6	190
<hr/>	
<b>CHAPTER 13</b>	<b>IPv6 Access Services: DHCPv6 Prefix Delegation 193</b>
Finding Feature Information	193
Information About IPv6 Access Services: DHCPv6 Prefix Delegation	193
DHCPv6 Prefix Delegation	193
Configuring Nodes Without Prefix Delegation	194
Client and Server Identification	194
Rapid Commit	194
DHCPv6 Client, Server, and Relay Functions	194
How to Configure IPv6 Access Services: DHCPv6 Prefix Delegation	198
Configuring the DHCPv6 Server Function	198
Configuring the DHCPv6 Configuration Pool	198
Configuring a Binding Database Agent for the Server Function	200
Configuring the DHCPv6 Client Function	201
Deleting Automatic Client Bindings from the DHCPv6 Binding Table	202
Configuration Examples for IPv6 Access Services: DHCPv6 Prefix Delegation	202
Example: Configuring the DHCPv6 Server Function	202
Example: Configuring the DHCPv6 Configuration Pool	204
Example: Configuring the DHCPv6 Client Function	205
Example: Configuring a Database Agent for the Server Function	205
Example: Displaying DHCP Server and Client Information on the Interface	205
Additional References	206

Feature Information for IPv6 Access Services: DHCPv6 Prefix Delegation 207

---

**CHAPTER 14**

**DHCP for IPv6 Broadband 209**

- Finding Feature Information 209
- Information About DHCP for IPv6 Broadband 209
  - Prefix Delegation 209
    - Accounting Start and Stop Messages 210
    - Forced Release of a Binding 210
- How to Configure DHCP for IPv6 Broadband 210
  - Enabling the Sending of Accounting Start and Stop Messages 210
  - Removing Delegated Prefix Bindings 211
- Configuration Examples for DHCP for IPv6 Broadband 212
  - Example: Enabling the Sending of Accounting Start and Stop Messages 212
  - Example: Configuration for a Prefix Allocated from a Local Pool 212
- Additional References 212
- Feature Information for DHCP for IPv6 Broadband 213

---

**CHAPTER 15**

**DHCPv6 Server Stateless Autoconfiguration 215**

- Finding Feature Information 215
- Information About DHCPv6 Server Stateless Autoconfiguration 215
  - DHCPv6 Server Stateless Autoconfiguration 215
- How to Configure DHCPv6 Server Stateless Autoconfiguration 217
  - Configuring the Stateless DHCPv6 Server 217
  - Configuring the Stateless DHCPv6 Client 218
  - Enabling Processing of Packets with Source Routing Header Options 219
- Configuration Examples for DHCPv6 Server Stateless Autoconfiguration 220
  - Example: Configuring the Stateless DHCPv6 Function 220
- Additional References for DHCP Overview 221
- Feature Information for DHCPv6 Server Stateless Autoconfiguration 221

---

**CHAPTER 16**

**DHCP Server MIB 223**

- Finding Feature Information 223
- Prerequisites for the DHCP Server MIB 223
- Information About the DHCP Server MIB 224

SNMP Overview	224
DHCP Server Trap Notifications	224
Tables and Objects in the DHCP Server MIB	224
How to Enable DHCP Trap Notifications	228
Configuring the Router to Send SNMP Trap Notifications About DHCP	228
Troubleshooting Tips	229
Configuration Examples for the DHCP Server MIB	230
DHCP Server MIB--Secondary Subnet Trap Example	230
DHCP Server MIB--Address Pool Trap Example	231
DHCP Server MIB--Lease Limit Violation Trap Example	231
Additional References	231
Feature Information for DHCP Server MIB	233





# CHAPTER 1

## Read Me First

---

### Important Information about Cisco IOS XE 16

Effective Cisco IOS XE Release 3.7.0E (for Catalyst Switching) and Cisco IOS XE Release 3.17S (for Access and Edge Routing) the two releases evolve (merge) into a single version of converged release—the Cisco IOS XE 16—providing one release covering the extensive range of access and edge products in the Switching and Routing portfolio.

### Feature Information

Use [Cisco Feature Navigator](#) to find information about feature support, platform support, and Cisco software image support. An account on Cisco.com is not required.

### Related References

- [Cisco IOS Command References, All Releases](#)

### Obtaining Documentation and Submitting a Service Request

For information on obtaining documentation, using the Cisco Bug Search Tool (BST), submitting a service request, and gathering additional information, see [What's New in Cisco Product Documentation](#).

To receive new and revised Cisco technical content directly to your desktop, you can subscribe to the . RSS feeds are a free service.







## CHAPTER 2

# Configuring the Cisco IOS XE DHCP Server

Cisco routers running Cisco IOS XE software include Dynamic Host Configuration Protocol (DHCP) server and relay agent software. The Cisco IOS XE DHCP server is a full DHCP server implementation that assigns and manages IP addresses from specified address pools within the router to DHCP clients. The DHCP server can be configured to assign additional parameters such as the IP address of the domain name system (DNS) server and the default router.

This module describes the concepts and the tasks needed to configure the DHCP server.

- [Finding Feature Information, on page 3](#)
- [Prerequisites for Configuring the DHCP Server, on page 3](#)
- [Information About the Cisco IOS XE DHCP Server, on page 4](#)
- [How to Configure the Cisco IOS XE DHCP Server, on page 9](#)
- [Configuration Examples for the Cisco IOS XE DHCP Server, on page 39](#)
- [Additional References, on page 46](#)
- [Feature Information for the Cisco IOS XE DHCP Server, on page 47](#)

## Finding Feature Information

Your software release may not support all the features documented in this module. For the latest caveats and feature information, see [Bug Search Tool](#) and the release notes for your platform and software release. To find information about the features documented in this module, and to see a list of the releases in which each feature is supported, see the feature information table.

Use Cisco Feature Navigator to find information about platform support and Cisco software image support. To access Cisco Feature Navigator, go to [www.cisco.com/go/cfn](http://www.cisco.com/go/cfn). An account on Cisco.com is not required.

## Prerequisites for Configuring the DHCP Server

- Before you configure a Cisco Dynamic Host Control Protocol (DHCP) server, you must understand the concepts documented in the [Overview of the DHCP Server](#) section.
- The Cisco DHCP server and the relay agent services are enabled by default. Use the **no service dhcp** command to disable the Cisco DHCP server and the relay agent and the **service dhcp** command to reenble the functionality.
- Port 67 (the DHCP server port) is closed in the Cisco DHCP/BOOTP default configuration. There are two logical parts to the **service dhcp** command: service enabled and service running. The DHCP service

is enabled by default, but port 67 does not open until the DHCP service is running. If the DHCP service is running, the **show ip sockets details** or the **show sockets detail** command displays port 67 as open.

- The Cisco DHCP relay agent is enabled on an interface only when you configure the **ip helper-address** command. This command enables a DHCP broadcast to be forwarded to the configured DHCP server.

# Information About the Cisco IOS XE DHCP Server

## Overview of the DHCP Server

The Cisco DHCP server accepts address assignment requests and renewals from the client and assigns the addresses from predefined groups of addresses within DHCP address pools. These address pools can also be configured to supply additional information to the requesting client such as the IP address of the Domain Name System (DNS) server, the default device, and other configuration parameters. The Cisco DHCP server can accept broadcasts from locally attached LAN segments or from DHCP requests that have been forwarded by other DHCP relay agents within the network.

## Database Agents

A DHCP database agent is any host (for example, an FTP, TFTP, or rcp server) or storage media on the DHCP server (for example, flash disk) that stores the DHCP bindings database. You can configure multiple DHCP database agents, and you can configure the interval between database updates and transfers for each agent.

Automatic bindings are IP addresses that have been automatically mapped to the MAC addresses of hosts that are found in the DHCP database. Automatic binding information (such as lease expiration date and time, interface index, and VPN routing and forwarding [VRF] name) is stored on a database agent. The bindings are saved as text records for easy maintenance.

## Address Conflicts

An address conflict occurs when two hosts use the same IP address. During address assignment, DHCP checks for conflicts using ping and gratuitous Address Resolution Protocol (ARP). If a conflict is detected, the address is removed from the pool. The address will not be assigned until the administrator resolves the conflict.

## DHCP Address Pool Conventions

You can configure a DHCP address pool with a name that is a symbolic string (such as “engineering”) or an integer (such as 0). Configuring a DHCP address pool also puts the router into DHCP pool configuration mode--identified by the (dhcp-config)# prompt--from which you can configure pool parameters (for example, the IP subnet number and default router list).

## DHCP Address Pool Selection

DHCP defines a process by which the DHCP server knows the IP subnet in which the DHCP client resides, and it can assign an IP address from a pool of valid IP addresses in that subnet. The process by which the DHCP server identifies which DHCP address pool to use to service a client request is described in this section.

The DHCP server identifies which DHCP address pool to use to service a client request as follows:

- If the client is not directly connected (the giaddr field of the DHCPDISCOVER broadcast message is non-zero), the DHCP server matches the DHCPDISCOVER with a DHCP pool that has the subnet that contains the IP address in the giaddr field. Giaddr field is the gateway IP address field of a DHCP packet. A DHCP relay agent sets the gateway address and adds the relay agent information option (option82) in the packet and forwards it to the DHCP server. The reply from the server is forwarded back to the client after removing option 82.
- If the client is directly connected (the giaddr field is zero), the DHCP server matches the DHCPDISCOVER with DHCP pool(s) that contain the subnet(s) configured on the receiving interface. If the interface has secondary IP addresses, the subnets associated with the secondary IP addresses are examined for possible allocation only after the subnet associated with the primary IP address (on the interface) is exhausted.

Cisco IOS XE DHCP server software supports advanced capabilities for IP address allocation. See the “DHCP Server Address Allocation Using Option 82” section for more information.

## Address Bindings

An address binding is a mapping between the IP address and MAC address of a client. The IP address of a client can be assigned manually by an administrator or assigned automatically from a pool by a DHCP server.

Manual bindings are IP addresses that have been manually mapped to the MAC addresses of hosts that are found in the DHCP database. Manual bindings are stored in NVRAM on the DHCP server. Manual bindings are just special address pools. There is no limit on the number of manual bindings, but you can only configure one manual binding per host pool.

Automatic bindings are IP addresses that have been automatically mapped to the MAC addresses of hosts that are found in the DHCP database. Because the bindings are stored in volatile memory on the DHCP server, binding information is lost in the event of a power failure or upon router reload for any other reason. To prevent the loss of automatic binding information in such an event, a copy of the automatic binding information can be stored on a remote host called a DHCP database agent. The bindings are periodically written to the database agent. If the router reloads, the bindings are read back from the database agent to the DHCP database on the DHCP server.



---

**Note** We strongly recommend using database agents. However, the Cisco IOS XE DHCP server can function without database agents.

---

All DHCP clients send a client identifier (DHCP option 61) in the DHCP packet. To configure manual bindings, you must enter the **client-identifier** DHCP pool configuration command with the appropriate hexadecimal values identifying the DHCP client.

## Ping Packet Settings

By default, the DHCP server pings a pool address twice before assigning a particular address to a requesting client. If the ping is unanswered, the DHCP server assumes (with a high probability) that the address is not in use and assigns the address to the requesting client.

By default, the DHCP server waits 2 seconds before timing out a ping packet.

## DHCP Attribute Inheritance

The DHCP server database is organized as a tree. The root of the tree is the address pool for natural networks, branches are subnetwork address pools, and leaves are manual bindings to clients. Subnetworks inherit network parameters and clients inherit subnetwork parameters. Therefore, common parameters (for example, the domain name) should be configured at the highest (network or subnetwork) level of the tree.

Inherited parameters can be overridden. For example, if a parameter is defined in both the natural network and a subnetwork, the definition of the subnetwork is used.

Address leases are not inherited. If a lease is not specified for an IP address, by default, the DHCP server assigns a one-day lease for the address.

## DHCP Server Address Allocation Using Option 82

The Cisco IOS DHCP server can allocate dynamic IP addresses based on the relay information option (option 82) sent by the relay agent.

DHCP provides a framework for passing configuration information to hosts on a TCP/IP network. Configuration parameters and other control information are carried in tagged data items that are stored in the options field of the DHCP message. The data items are also called options. Option 82 is organized as a single DHCP option that contains information known by the relay agent.

Automatic DHCP address allocation is based on an IP address. This IP address can either be the gateway address (giaddr field of the DHCP packet) or the IP address of an incoming interface. In some networks, it is necessary to use additional information to further determine which IP addresses to allocate. By using option 82, the Cisco IOS DHCP relay agent can include additional information about itself when forwarding client-originated DHCP packets to a DHCP server. The Cisco IOS DHCP server can also use option 82 to provide additional information to properly allocate IP addresses to DHCP clients. The information sent via option 82 is used to identify the port where the DHCP request arrives. Automatic DHCP address allocation does not parse out the individual suboptions contained in option 82. Rather, the address allocation is done by matching a configured pattern byte by byte.

This feature introduces a new DHCP class capability, which is a method to group DHCP clients based on some shared characteristics other than the subnet in which the clients reside.

For example, DHCP clients are connected to two ports of a single switch. Each port can be configured to be a part of two VLANs: VLAN1 and VLAN2. DHCP clients belong to either VLAN1 or VLAN2 and the switch can differentiate the VLAN that a particular DHCP Discover message belongs to (possibly through Layer 2 encapsulation). Each VLAN has its own subnet and all DHCP messages from the same VLAN (same switch) have the giaddr field set to the same value indicating the subnet of the VLAN.

Problems can occur while allocating IP addresses to DHCP clients that are connected to different ports of the same VLAN. These IP addresses must be part of the same subnet but the range of IP addresses must be different. In the preceding example, when a DHCP client that is connected to a port of VLAN1 must be allocated an IP address from a range of IP addresses within the VLAN's subnet, whereas a DHCP client connecting to port 2 of VLAN1 must be allocated an IP address from another range of IP addresses. The two ranges of IP addresses are part of the same subnet (and have the same subnet mask). Generally, during DHCP address allocation, the DHCP server refers only to the giaddr field and is unable to differentiate between the two ranges.

To solve this problem, a relay agent residing at the switch inserts the relay information option (option 82), which carries information specific to the port, and the DHCP server inspects both the giaddr field and the inserted option 82 during the address selection process.

When you enable option 82 on a device, the following sequence of events occurs:

1. The host (DHCP client) generates a DHCP request and broadcasts it on the network.
2. When the device receives the DHCP request, it adds the option 82 information in the packet. The option 82 information contains the device MAC address (the remote ID suboption) and the port identifier, vlan-mod-port, from which the packet is received (the circuit ID suboption).
3. The device adds the IP address of the relay agent to the DHCP packet.
4. The device forwards the DHCP request that includes the option 82 field to the DHCP server.
5. The DHCP server receives the packet. If the server is option 82 capable, it uses the remote ID, the circuit ID, or both to assign IP addresses and implement policies, such as restricting the number of IP addresses that can be assigned to a single remote ID or circuit ID. The DHCP server echoes the option 82 field in the DHCP reply.
6. The DHCP server unicasts the reply to the device if the request is relayed to the server by the device. The device verifies that it originally inserted the option 82 data by inspecting remote ID and possibly circuit ID fields. The device removes the option 82 field and forwards the packet to the interface that connects to the DHCP client that sent the DHCP request.

The Cisco software refers to a pool of IP addresses (giaddr or incoming interface IP address) and matches the request to a class or classes configured in the pool in the order the classes are specified in the DHCP pool configuration.

When a DHCP address pool is configured with one or more DHCP classes, the pool becomes a restricted access pool, which means that no addresses are allocated from the pool unless one or more classes in the pool matches. This design allows DHCP classes to be used either for access control (no default class is configured on the pool) or to provide further address range partitions within the subnet of the pool.

Multiple pools can be configured with the same class, eliminating the need to configure the same pattern in multiple pools.

The following capabilities are supported for DHCP class-based address allocation:

- Specifying the full relay agent information option value as a raw hexadecimal string by using the **relay-information hex** command in new relay agent information configuration mode.
- Support for bit-masking the raw relay information hexadecimal value.
- Support for a wildcard at the end of a hexadecimal string specified by the **relay-information hex** command.

If the relay agent inserts option 82 but does not set the giaddr field in the DHCP packet, the DHCP server interface must be configured as a trusted interface by using the **ip dhcp relay information trusted** command. This configuration prevents the server from dropping the DHCP message.

## DHCP Address Allocation Using Option 82 Feature Design

DHCP provides a framework for passing configuration information to hosts on a TCP/IP network. Configuration parameters and other control information are carried in tagged data items that are stored in the options field of the DHCP message. The data items themselves are also called options. Option 82 is organized as a single DHCP option that contains information known by the relay agent.

This feature is designed to allow the Cisco IOS XE DHCP server to use option 82 information to help determine which IP addresses to allocate to clients. The information sent via option 82 will be used to identify which port the DHCP request came in on. This feature does not parse out the individual suboptions contained within option 82. Rather, the address allocation is done by matching a configured pattern byte by byte.

The feature introduces a new DHCP class capability, which is a method to group DHCP clients based on some shared characteristics other than the subnet in which the clients reside.

## Usage Scenario for DHCP Address Allocation Using Option 82

In an example application, DHCP clients are connected to two ports of a single switch. Each port can be configured to be part of two VLANs: VLAN1 and VLAN2. DHCP clients belong to either VLAN1 or VLAN2 and it is assumed that the switch can differentiate the VLAN that a particular DHCP Discover message belongs to (possibly through Layer 2 encapsulation). Each VLAN has its own subnet and all DHCP messages from the same VLAN (same switch) will have the giaddr field set to the same value indicating the subnet of the VLAN.

The problem is that for a DHCP client connecting to port 1 of VLAN1, it must be allocated an IP address from one range within the VLAN's subnet, whereas a DHCP client connecting to port 2 of VLAN1 must be allocated an IP address from another range. Both these two IP address ranges are part of the same subnet (and have the same subnet mask). In the normal DHCP address allocation, the DHCP server will look only at the giaddr field and thus will not be able to differentiate between the two ranges.

To solve this problem, a relay agent residing at the switch inserts the relay information option (option 82), which carries information specific to the port, and the DHCP server must inspect both the giaddr field and the inserted option 82 during the address selection process.

## DHCP Class Capability

The Cisco IOS XE software will look up a pool based on IP address (giaddr or incoming interface IP address) and then match the request to a class or classes configured in the pool in the order the classes are specified in the DHCP pool configuration.

When a DHCP address pool has been configured with one or more DHCP classes, the pool becomes a restricted access pool, which means that no addresses will be allocated from the pool unless one or more of the classes in the pool is matched. This design allows DHCP classes to be used for either access control (no default class is configured on the pool) or to provide further address range partitions with the subnet of the pool.

Multiple pools can be configured with the same class, eliminating the need to configure the same pattern in multiple pools.

The following capabilities are currently supported for DHCP class-based address allocation:

- Specifying the full relay agent information option value as a raw hexadecimal string by using the **relay-information hex** command in the new relay agent information configuration mode.
- Support for bitmasking the raw relay information hexadecimal value.
- Support for a wildcard at the end of the hexadecimal string specified by the **relay-information hex** command.

## RegEx and Longest Match Support

DHCP server software supports advanced capabilities for IP address allocation. Earlier, DHCP server supported only exact match on hexadecimal codes. Effective with Cisco IOS XE Fuji 16.9.1, DHCP server is enhanced to support Regular expression (RegEx) based match or longest match. DHCP server provides options to set of DHCP clients with Vendor Class ID (VCI). Each set of clients are serviced from specific DHCP pool with one or more Vendor Classes. RegEx based Vendor Class Identifier match is included to support this feature.

For one class option, either Exact Match or RegEx Match or Longest Match is supported. The configured RegEx or hexadecimal string is matched against VCI string received in DHCP packets. In case of successful

match, server assigns an IP address from the address range specified in pool class configuration. In case of multiple class match, the first occurrence of the match is considered. In case of no match, no address is allocated.

# How to Configure the Cisco IOS XE DHCP Server

## Configuring a DHCP Database Agent or Disabling Conflict Logging

A DHCP database agent is any host (for example, an FTP, a TFTP, or a remote copy protocol [RCP] server) or storage media on a DHCP server (for example, disk0) that stores the DHCP bindings database. You can configure multiple DHCP database agents, and the interval between database updates and transfers for each agent.

Automatic bindings are IP addresses that are automatically mapped to the MAC addresses of hosts that are found in the DHCP database. Automatic binding information (such as lease expiration date and time, interface index, and VPN routing and forwarding [VRF] name) is stored in a database agent. The bindings are saved as text records for easy maintenance.

An address conflict occurs when two hosts use the same IP address. During address assignment, DHCP checks for conflicts by using ping and gratuitous Address Resolution Protocol (ARP). If a conflict is detected, the address is removed from the pool. The address is not assigned until the administrator resolves the conflict.



**Note** We strongly recommend using database agents. However, the Cisco DHCP server can run without database agents. If you choose not to configure a DHCP database agent, disable the recording of DHCP address conflicts on the DHCP server by using the **no ip dhcp conflict logging** command in global configuration mode. If there is a conflict logging but no database agent is configured, bindings during a switchover are lost when a device reboots. Possible false conflicts can occur causing the address to be removed from the address pool.

### SUMMARY STEPS

1. **enable**
2. **configure terminal**
3. Do one of the following:
  - **ip dhcp database url [timeout seconds | write-delay seconds]**
  - **no ip dhcp conflict logging**
4. **end**

### DETAILED STEPS

	Command or Action	Purpose
Step 1	<b>enable</b>  <b>Example:</b>  Device> enable	Enables privileged EXEC mode. <ul style="list-style-type: none"> <li>• Enter your password if prompted.</li> </ul>

	Command or Action	Purpose
<b>Step 2</b>	<b>configure terminal</b> <b>Example:</b> <pre>Device# configure terminal</pre>	Enters global configuration mode.
<b>Step 3</b>	Do one of the following: <ul style="list-style-type: none"> <li>• <b>ip dhcp database</b> <i>url</i> [<i>timeout seconds</i>   <b>write-delay</b> <i>seconds</i>]</li> <li>• <b>no ip dhcp conflict logging</b></li> </ul> <b>Example:</b> <pre>Device(config)# ip dhcp database ftp://user:password@172.16.1.1/router-dhcp timeout 80</pre> <b>Example:</b> <pre>Device(config)# no ip dhcp conflict logging</pre>	Configures a DHCP server to save automatic bindings on a remote host called a database agent. or Disables DHCP address conflict logging.
<b>Step 4</b>	<b>end</b> <b>Example:</b> <pre>Device(config)# end</pre>	Exits global configuration mode and returns to privileged EXEC mode.

## Excluding IP Addresses

The IP address configured on a device interface is automatically excluded from the DHCP address pool. The DHCP server assumes that all other IP addresses in a DHCP address pool subnet are available for assigning to DHCP clients.

You must exclude addresses from the pool if the DHCP server does not allocate those IP addresses to DHCP clients. Consider a scenario where two DHCP servers are set up for the same network segment (subnet) for redundancy. If DHCP servers do not coordinate their services with each other using a protocol such as DHCP failover, each DHCP server must be configured to allocate addresses from a nonoverlapping set of addresses in the shared subnet. See the [Configuring Manual Bindings](#) section for a configuration example.

### SUMMARY STEPS

1. **enable**
2. **configure terminal**
3. **ip dhcp excluded-address** *low-address* [*high-address*]
4. **end**

### DETAILED STEPS

	Command or Action	Purpose
<b>Step 1</b>	<b>enable</b>	Enables privileged EXEC mode.



	Command or Action	Purpose
	<b>Example:</b> Device> enable	<ul style="list-style-type: none"> <li>• Enter your password if prompted.</li> </ul>
<b>Step 2</b>	<b>configure terminal</b> <b>Example:</b> Device# configure terminal	Enters global configuration mode.
<b>Step 3</b>	<b>ip dhcp excluded-address</b> <i>low-address</i> [ <i>high-address</i> ] <b>Example:</b> Device(config)# ip dhcp excluded-address 172.16.1.100 172.16.1.103	Specifies IP addresses that the DHCP server should not assign to DHCP clients.
<b>Step 4</b>	<b>end</b> <b>Example:</b> Device(config)# end	Exits global configuration mode and returns to privileged EXEC mode.

## Configuring DHCP Address Pools

### Configuring a DHCP Address Pool

On a per-address pool basis, specify DHCP options for the client as necessary.

You can configure a DHCP address pool with a name that is a string (such as “engineering”) or an integer (such as 0). Configuring a DHCP address pool also puts the device into DHCP pool configuration mode—identified by the (dhcp-config)# prompt—from which you can configure pool parameters (for example, the IP subnet number and default device list).

DHCP defines a process by which the DHCP server knows the IP subnet in which the DHCP client resides, and it can assign an IP address from a pool of valid IP addresses in that subnet. The process by which the DHCP server identifies the DHCP address pool to use for a client request is described in the [Configuring Manual Bindings](#) section.

The DHCP server identifies and uses DHCP address pools for a client request, in the following manner:

- If the client is not directly connected to the DHCP server (the giaddr field of the DHCPDISCOVER broadcast message is nonzero), the server matches the DHCPDISCOVER with the DHCP pool that has the subnet that contains the IP address in the giaddr field.
- If the client is directly connected to the DHCP server (the giaddr field is zero), the DHCP server matches the DHCPDISCOVER with DHCP pools that contain the subnets configured on the receiving interface. If the interface has secondary IP addresses, subnets associated with the secondary IP addresses are examined for possible allocation only after the subnet associated with the primary IP address (on the interface) is exhausted.

Cisco DHCP server software supports advanced capabilities for IP address allocation. See the [Configuring DHCP Address Allocation Using Option 82](#) section for more information.

**Before you begin**

Before you configure the DHCP address pool, you must:

- Identify DHCP options for devices where necessary, including the following:
  - Default boot image name
  - Default devices
  - Domain Name System (DNS) servers
  - Network Basic Input/Output System (NetBIOS) name server
  - Primary subnet
  - Secondary subnets and subnet-specific default device lists (see [Configuring a DHCP Address Pool with Secondary Subnets](#) for information on secondary subnets).
- Decide on a NetBIOS node type (b, p, m, or h).
- Decide on a DNS domain name.

**Note**

You cannot configure manual bindings within the same pool that is configured with the **network** DHCP pool configuration command. To configure manual bindings, see the [Configuring Manual Bindings](#) section.

**SUMMARY STEPS**

1. **enable**
2. **configure terminal**
3. **ip dhcp pool** *name*
4. **utilization mark high** *percentage-number* [**log**]
5. **utilization mark low** *percentage-number* [**log**]
6. **network** *network-number* [*mask* | *prefix-length*] [**secondary**]
7. **domain-name** *domain*
8. **dns-server** *address* [*address2* ... *address8*]
9. **bootfile** *filename*
10. **next-server** *address* [*address2* ... *address8*]
11. **netbios-name-server** *address* [*address2* ... *address8*]
12. **netbios-node-type** *type*
13. **default-router** *address* [*address2* ... *address8*]
14. **option** *code* [*instance number*] {*ascii string* | *hex string* | *ip-address*}
15. **import** {**all** | **interface** *interface\_name*}
16. **lease** {*days* [*hours* [*minutes*]] | **infinite**}
17. **end**

## DETAILED STEPS

	Command or Action	Purpose
Step 1	<b>enable</b> <b>Example:</b> Device> enable	Enables privileged EXEC mode. <ul style="list-style-type: none"> <li>• Enter your password if prompted.</li> </ul>
Step 2	<b>configure terminal</b> <b>Example:</b> Device# configure terminal	Enters global configuration mode.
Step 3	<b>ip dhcp pool <i>name</i></b> <b>Example:</b> Device(config)# ip dhcp pool 1	Creates a name for the DHCP server address pool and enters DHCP pool configuration mode.
Step 4	<b>utilization mark high <i>percentage-number</i> [log]</b> <b>Example:</b> Device(dhcp-config)# utilization mark high 80 log	(Optional) Configures the high utilization mark of the current address pool size. <ul style="list-style-type: none"> <li>• The <b>log</b> keyword enables the logging of a system message. A system message will be generated for a DHCP pool when the pool utilization exceeds the configured high utilization threshold.</li> </ul>
Step 5	<b>utilization mark low <i>percentage-number</i> [log]</b> <b>Example:</b> Device(dhcp-config)# utilization mark low 70 log	(Optional) Configures the low utilization mark of the current address pool size. <ul style="list-style-type: none"> <li>• The <b>log</b> keyword enables the logging of a system message. A system message will be generated for a DHCP pool when the pool utilization falls below the configured low utilization threshold.</li> </ul>
Step 6	<b>network <i>network-number</i> [<i>mask</i>   /<i>prefix-length</i>]</b> <b>[secondary]</b> <b>Example:</b> Device(dhcp-config)# network 172.16.0.0 /16	Specifies the subnet network number and mask of the DHCP address pool.
Step 7	<b>domain-name <i>domain</i></b> <b>Example:</b> Device(dhcp-config)# domain-name cisco.com	Specifies the domain name for the client.
Step 8	<b>dns-server <i>address</i> [<i>address2</i> ... <i>address8</i>]</b> <b>Example:</b> Device(dhcp-config)# dns server 172.16.1.103 172.16.2.103	Specifies the IP address of a DNS server that is available to a DHCP client. <ul style="list-style-type: none"> <li>• One IP address is required; however, you can specify up to eight IP addresses in one command.</li> </ul>

	Command or Action	Purpose
		<ul style="list-style-type: none"> <li>Servers should be listed in order of preference.</li> </ul>
<b>Step 9</b>	<b>bootfile</b> <i>filename</i> <b>Example:</b> <pre>Device(dhcp-config)# bootfile xllboot</pre>	(Optional) Specifies the name of the default boot image for a DHCP client. <ul style="list-style-type: none"> <li>The boot file is used to store the boot image for the client. The boot image is generally the operating system that the client uses to load.</li> </ul>
<b>Step 10</b>	<b>next-server</b> <i>address</i> [ <i>address2</i> ... <i>address8</i> ] <b>Example:</b> <pre>Device(dhcp-config)# next-server 172.17.1.103 172.17.2.103</pre>	(Optional) Configures the next server in the boot process of a DHCP client. <ul style="list-style-type: none"> <li>One address is required; however, you can specify up to eight addresses in one command line.</li> <li>If multiple servers are specified, DHCP assigns them to clients in a round-robin order. The first client gets address 1, the next client gets address 2, and so on.</li> <li>If this command is not configured, DHCP uses the server specified by the <b>ip helper address</b> command as the boot server.</li> </ul>
<b>Step 11</b>	<b>netbios-name-server</b> <i>address</i> [ <i>address2</i> ... <i>address8</i> ] <b>Example:</b> <pre>Device(dhcp-config)# netbios-name-server 172.16.1.103 172.16.2.103</pre>	(Optional) Specifies the NetBIOS WINS server that is available to a Microsoft DHCP client. <ul style="list-style-type: none"> <li>One address is required; however, you can specify up to eight addresses in one command line.</li> <li>Servers should be listed in order of preference.</li> </ul>
<b>Step 12</b>	<b>netbios-node-type</b> <i>type</i> <b>Example:</b> <pre>Device(dhcp-config)# netbios-node-type h-node</pre>	(Optional) Specifies the NetBIOS node type for a Microsoft DHCP client.
<b>Step 13</b>	<b>default-router</b> <i>address</i> [ <i>address2</i> ... <i>address8</i> ] <b>Example:</b> <pre>Device(dhcp-config)# default-router 172.16.1.100 172.16.1.101</pre>	(Optional) Specifies the IP address of the default device for a DHCP client. <ul style="list-style-type: none"> <li>The IP address should be on the same subnet as the client.</li> <li>One IP address is required; however, you can specify up to eight IP addresses in one command line. These default devices are listed in order of preference; that is, <i>address</i> is the most preferred device, <i>address2</i> is the next most preferred device, and so on.</li> <li>When a DHCP client requests an IP address, the device—acting as a DHCP server—accesses the default device list to select another device that the DHCP client will use as the first hop for forwarding</li> </ul>

	Command or Action	Purpose
		messages. After a DHCP client has booted, the client begins sending packets to its default device.
<b>Step 14</b>	<b>option code</b> [ <i>instance number</i> ] { <i>ascii string</i>   <i>hex string</i>   <i>ip-address</i> } <b>Example:</b> <pre>Device(dhcp-config)# option 19 hex 01</pre>	(Optional) Configures DHCP server options. Configuration supports Longest match and RegEx match for option 60. The <b>option code</b> sub command can be used to configure any DHCP options.
<b>Step 15</b>	<b>import</b> { <b>all</b>   <b>interface</b> <i>interface_name</i> } <b>Example:</b> <pre>Device(dhcp-config)# import all Device(dhcp-config) # import interface Ethernet0/0</pre>	The <b>import all</b> command learns options from all the interfaces. The <b>import interface</b> learns options only from the specified interface.
<b>Step 16</b>	<b>lease</b> { <i>days</i> [ <i>hours</i> [ <i>minutes</i> ]]   <b>infinite</b> } <b>Example:</b> <pre>Device(dhcp-config)# lease 30</pre>	(Optional) Specifies the duration of the lease. <ul style="list-style-type: none"> <li>• The default is a one-day lease.</li> <li>• The <b>infinite</b> keyword specifies that the duration of the lease is unlimited.</li> </ul>
<b>Step 17</b>	<b>end</b> <b>Example:</b> <pre>Device(dhcp-config)# end</pre>	Returns to privileged EXEC mode.

## Configuring a DHCP Address Pool with Secondary Subnets

For any DHCP pool, you can configure a primary subnet and any number of secondary subnets. Each subnet is a range of IP addresses that the device uses to allocate an IP address to a DHCP client. The DHCP server multiple subnet functionality enables a Cisco DHCP server address pool to manage additional IP addresses by adding the addresses to a secondary subnet of an existing DHCP address pool (instead of using a separate address pool).

Configuring a secondary DHCP subnetwork places the device in DHCP pool secondary subnet configuration mode—identified by the (config-dhcp-subnet-secondary)# prompt—where you can configure a default address list that is specific to the secondary subnet. You can also specify the utilization rate of the secondary subnet, which allows pools of IP addresses to dynamically increase or reduce in size depending on the address utilization level. This setting overrides the global utilization rate.

If the DHCP server selects an address pool that contains multiple subnets, the DHCP server allocates an IP address from the subnets as follows:

- When the DHCP server receives an address assignment request, it looks for an available IP address in the primary subnet.
- When the primary subnet is exhausted, the DHCP server automatically looks for an available IP address in any of the secondary subnets maintained by the DHCP server (even though the giaddr does not

necessarily match the secondary subnet). The server inspects the subnets for address availability in the order of subnets that were added to the pool.

- If the giaddr matches a secondary subnet in the pool, the DHCP server allocates an IP address from that particular secondary subnet (even if IP addresses are available in the primary subnet and irrespective of the order of secondary subnets that were added).

## SUMMARY STEPS

1. **enable**
2. **configure terminal**
3. **ip dhcp pool** *name*
4. **utilization mark high** *percentage-number* [**log**]
5. **utilization mark low** *percentage-number* [**log**]
6. **network** *network-number* [*mask* | *prefix-length*]
7. **domain-name** *domain*
8. **dns-server** *address* [*address2* ... *address8*]
9. **bootfile** *filename*
10. **next-server** *address* [*address2* ... *address8*]
11. **netbios-name-server** *address* [*address2* ... *address8*]
12. **netbios-node-type** *type*
13. **default-router** *address* [*address2* ... *address8*]
14. **option** *code* [*instance number*] {*ascii string* | *hex string* | *ip-address*}
15. **lease** {*days* [*hours*] [*minutes*] | **infinite**}
16. **network** *network-number* [*mask* | *prefix-length*] [**secondary**]
17. **override default-router** *address* [*address2* ... *address8*]
18. **override utilization high** *percentage-number*
19. **override utilization low** *percentage-number*
20. **end**

## DETAILED STEPS

	Command or Action	Purpose
<b>Step 1</b>	<b>enable</b> <b>Example:</b> Device> enable	Enables privileged EXEC mode. <ul style="list-style-type: none"> <li>• Enter your password if prompted.</li> </ul>
<b>Step 2</b>	<b>configure terminal</b> <b>Example:</b> Device# configure terminal	Enters global configuration mode.
<b>Step 3</b>	<b>ip dhcp pool</b> <i>name</i> <b>Example:</b> Device(config)# ip dhcp pool 1	Creates a name for the DHCP server address pool and enters DHCP pool configuration mode.

	Command or Action	Purpose
Step 4	<p><b>utilization mark high</b> <i>percentage-number</i> [<b>log</b>]</p> <p><b>Example:</b></p> <pre>Device(dhcp-config)# utilization mark high 80 log</pre>	<p>(Optional) Configures the high utilization mark of the current address pool size.</p> <ul style="list-style-type: none"> <li>The <b>log</b> keyword enables logging of a system message. A system message is generated for a DHCP pool when the pool utilization exceeds the configured high utilization threshold.</li> </ul>
Step 5	<p><b>utilization mark low</b> <i>percentage-number</i> [<b>log</b>]</p> <p><b>Example:</b></p> <pre>Device(dhcp-config)# utilization mark low 70 log</pre>	<p>(Optional) Configures the low utilization mark of the current address pool size.</p> <ul style="list-style-type: none"> <li>The <b>log</b> keyword enables logging of a system message. A system message is generated for a DHCP pool when the pool utilization falls below the configured low utilization threshold.</li> </ul>
Step 6	<p><b>network</b> <i>network-number</i> [<i>mask</i>   <i>/prefix-length</i>]</p> <p><b>Example:</b></p> <pre>Device(dhcp-config)# network 172.16.0.0 /16</pre>	Specifies the subnet network number and mask of the primary DHCP address pool.
Step 7	<p><b>domain-name</b> <i>domain</i></p> <p><b>Example:</b></p> <pre>Device(dhcp-config)# domain-name cisco.com</pre>	Specifies the domain name for the client.
Step 8	<p><b>dns-server</b> <i>address</i> [<i>address2</i> ... <i>address8</i>]</p> <p><b>Example:</b></p> <pre>Device(dhcp-config)# dns server 172.16.1.103 172.16.2.103</pre>	<p>Specifies the IP address of a DNS server that is available to a DHCP client.</p> <ul style="list-style-type: none"> <li>One IP address is required; however, you can specify up to eight IP addresses in one command.</li> <li>Servers should be listed in the order of preference.</li> </ul>
Step 9	<p><b>bootfile</b> <i>filename</i></p> <p><b>Example:</b></p> <pre>Device(dhcp-config)# bootfile xllboot</pre>	<p>(Optional) Specifies the name of the default boot image for a DHCP client.</p> <ul style="list-style-type: none"> <li>The boot file is used to store the boot image for the client. The boot image is generally the operating system image that the client loads.</li> </ul>
Step 10	<p><b>next-server</b> <i>address</i> [<i>address2</i> ... <i>address8</i>]</p> <p><b>Example:</b></p> <pre>Device(dhcp-config)# next-server 172.17.1.103 172.17.2.103</pre>	<p>(Optional) Configures the next server in the boot process of a DHCP client.</p> <ul style="list-style-type: none"> <li>One IP address is required; however, you can specify up to eight IP addresses in one command line.</li> <li>If multiple servers are specified, DHCP assigns the servers to clients in a round-robin order. The first client gets address 1, the next client gets address 2, and so on.</li> </ul>

	Command or Action	Purpose
		<ul style="list-style-type: none"> <li>If this command is not configured, DHCP uses the server specified by the <b>ip helper address</b> command as the boot server.</li> </ul>
<b>Step 11</b>	<b>netbios-name-server</b> <i>address</i> [ <i>address2 ... address8</i> ] <b>Example:</b> <pre>Device(dhcp-config)# netbios-name-server 172.16.1.103 172.16.2.103</pre>	(Optional) Specifies the NetBIOS Windows Internet Naming Service (WINS) server that is available to a Microsoft DHCP client. <ul style="list-style-type: none"> <li>One address is required; however, you can specify up to eight addresses in one command line.</li> <li>Servers should be listed in order of preference.</li> </ul>
<b>Step 12</b>	<b>netbios-node-type</b> <i>type</i> <b>Example:</b> <pre>Device(dhcp-config)# netbios-node-type h-node</pre>	(Optional) Specifies the NetBIOS node type for a Microsoft DHCP client.
<b>Step 13</b>	<b>default-router</b> <i>address</i> [ <i>address2 ... address8</i> ] <b>Example:</b> <pre>Device(dhcp-config)# default-router 172.16.1.100 172.16.1.101</pre>	(Optional) Specifies the IP address of the default device for a DHCP client. <ul style="list-style-type: none"> <li>The IP address should be on the same subnet as the client.</li> <li>One IP address is required; however, you can specify a up to eight IP addresses in one command line. These default devices are listed in order of preference; that is, <i>address</i> is the most preferred device, <i>address2</i> is the next most preferred device, and so on.</li> <li>When a DHCP client requests for an IP address, the device—acting as a DHCP server—accesses the default device list to select another device that the DHCP client uses as the first hop for forwarding messages. After a DHCP client has booted, the client begins sending packets to its default device.</li> </ul>
<b>Step 14</b>	<b>option</b> <i>code</i> [ <i>instance number</i> ] { <i>ascii string</i>   <b>hex string</b>   <i>ip-address</i> } <b>Example:</b> <pre>Device(dhcp-config)# option 19 hex 01</pre>	(Optional) Configures DHCP server options.
<b>Step 15</b>	<b>lease</b> { <i>days</i> [ <i>hours</i> ] [ <i>minutes</i> ]   <b>infinite</b> } <b>Example:</b> <pre>Device(dhcp-config)# lease 30</pre>	(Optional) Specifies the duration of the lease. <ul style="list-style-type: none"> <li>The default is a one-day lease.</li> <li>The <b>infinite</b> keyword specifies that the duration of the lease is unlimited.</li> </ul>



	Command or Action	Purpose
Step 16	<p><b>network</b> <i>network-number</i> [<i>mask</i>   <i>/prefix-length</i>] [<b>secondary</b>]</p> <p><b>Example:</b></p> <pre>Device(dhcp-config)# network 10.10.0.0 255.255.0.0 secondary</pre>	<p>(Optional) Specifies the network number and mask of a secondary DHCP server address pool.</p> <ul style="list-style-type: none"> <li>Any number of secondary subnets can be added to a DHCP server address pool.</li> <li>During execution of this command, the configuration mode changes to DHCP pool secondary subnet configuration mode, which is identified by (config-dhcp-subnet-secondary)# prompt. In this mode, the administrator can configure a default device list that is specific to the subnet.</li> <li>See <a href="#">Troubleshooting Tips</a> section if you are using secondary IP addresses under a loopback interface with DHCP secondary subnets.</li> </ul>
Step 17	<p><b>override default-router</b> <i>address</i> [<i>address2</i> ... <i>address8</i>]</p> <p><b>Example:</b></p> <pre>Device(config-dhcp-subnet-secondary)# override default-router 10.10.0.100 10.10.0.101</pre>	<p>(Optional) Specifies the default device list that is used when an IP address is assigned to a DHCP client from a particular secondary subnet.</p> <ul style="list-style-type: none"> <li>If the subnet-specific override value is configured, this override value is used when assigning an IP address from the subnet; the network-wide default device list is used only to set the gateway device for the primary subnet.</li> <li>If this subnet-specific override value is not configured, the network-wide default device list is used when assigning an IP address from the subnet.</li> <li>See <a href="#">Example: Configuring a DHCP Address Pool with Multiple Disjoint Subnets</a> section for a sample configuration.</li> </ul>
Step 18	<p><b>override utilization high</b> <i>percentage-number</i></p> <p><b>Example:</b></p> <pre>Device(config-dhcp-subnet-secondary)# override utilization high 60</pre>	<p>(Optional) Sets the high utilization mark of the subnet size.</p> <ul style="list-style-type: none"> <li>This command overrides the global default setting specified by the <b>utilization mark high</b> command.</li> </ul>
Step 19	<p><b>override utilization low</b> <i>percentage-number</i></p> <p><b>Example:</b></p> <pre>Device(config-dhcp-subnet-secondary)# override utilization low 40</pre>	<p>(Optional) Sets the low utilization mark of the subnet size.</p> <ul style="list-style-type: none"> <li>This command overrides the global default setting specified by the <b>utilization mark low</b> command.</li> </ul>
Step 20	<p><b>end</b></p> <p><b>Example:</b></p> <pre>Device(config-dhcp-subnet-secondary)# end</pre>	<p>Returns to privileged EXEC mode.</p>

## Troubleshooting Tips

If you are using secondary IP addresses under a single loopback interface and using secondary subnets under a DHCP pool, use one DHCP pool to configure networks for all the secondary subnets instead of using one pool per secondary subnet. The **network** *network-number* [*mask* | *prefix-length*] [**secondary**] command must be configured under a single DHCP address pool rather than multiple DHCP address pools.

The following is the correct configuration:

```
!
ip dhcp pool dhcp_1
 network 172.16.1.0 255.255.255.0
 network 172.16.2.0 255.255.255.0 secondary
 network 172.16.3.0 255.255.255.0 secondary
 network 172.16.4.0 255.255.255.0 secondary
!
interface Loopback111
 ip address 172.16.1.1 255.255.255.255 secondary
 ip address 172.16.2.1 255.255.255.255 secondary
 ip address 172.16.3.1 255.255.255.255 secondary
 ip address 172.16.4.1 255.255.255.255 secondary
```

The following is the incorrect configuration:

```
!
ip dhcp pool dhcp_1
 network 172.16.1.0 255.255.255.0
 lease 1 20 30
 accounting default
!
ip dhcp pool dhcp_2
 network 172.16.2.0 255.255.255.0
 lease 1 20 30
 accounting default
!
ip dhcp pool dhcp_3
 network 172.16.3.0 255.255.255.0
 lease 1 20 30
 accounting default
!
ip dhcp pool dhcp_4
 network 172.16.4.0 255.255.255.0
 lease 1 20 30
 accounting default
!
interface Loopback111
 ip address 172.16.1.1 255.255.255.255 secondary
 ip address 172.16.2.1 255.255.255.255 secondary
 ip address 172.16.3.1 255.255.255.255 secondary
 ip address 172.16.4.1 255.255.255.255 secondary
```

## Verifying the DHCP Address Pool Configuration

The following configuration commands are optional. You can enter the **show** commands in any order.

### SUMMARY STEPS

1. **enable**
2. **show ip dhcp pool** [*name*]
3. **show ip dhcp binding** [*address*]

4. **show ip dhcp conflict** *[address]*
5. **show ip dhcp database** *[url]*
6. **show ip dhcp server statistics** *[type-number]*

## DETAILED STEPS

	Command or Action	Purpose
<b>Step 1</b>	<b>enable</b> <b>Example:</b> Device> enable	Enables privileged EXEC mode. <ul style="list-style-type: none"> <li>• Enter your password if prompted.</li> </ul>
<b>Step 2</b>	<b>show ip dhcp pool</b> <i>[name]</i> <b>Example:</b> Device# show ip dhcp pool	(Optional) Displays information about DHCP address pools.
<b>Step 3</b>	<b>show ip dhcp binding</b> <i>[address]</i> <b>Example:</b> Device# show ip dhcp binding	(Optional) Displays a list of all bindings created on a specific DHCP server. <ul style="list-style-type: none"> <li>• Use the <b>show ip dhcp binding</b> command to display the IP addresses that have already been assigned. Verify that the address pool is not exhausted. If necessary, recreate the pool to create a larger pool of addresses.</li> <li>• Use the <b>show ip dhcp binding</b> command to display the lease expiration date and time of the IP address of the host.</li> </ul>
<b>Step 4</b>	<b>show ip dhcp conflict</b> <i>[address]</i> <b>Example:</b> Device# show ip dhcp conflict	(Optional) Displays a list of all IP address conflicts.
<b>Step 5</b>	<b>show ip dhcp database</b> <i>[url]</i> <b>Example:</b> Device# show ip dhcp database	(Optional) Displays recent activity on the DHCP database.
<b>Step 6</b>	<b>show ip dhcp server statistics</b> <i>[type-number]</i> <b>Example:</b> Device# show ip dhcp server statistics	(Optional) Displays count information about server statistics and messages sent and received.

## Configuring Manual Bindings

An address binding is a mapping between the IP address and MAC address of a client. The IP address of a client can be assigned manually by an administrator or assigned automatically from a pool by a DHCP server.

Manual bindings are IP addresses that are manually mapped to MAC addresses of hosts that are found in the DHCP database. Manual bindings are stored in the NVRAM of the DHCP server. Manual bindings are just special address pools. There is no limit to the number of manual bindings, but you can configure only one manual binding per host pool.

Automatic bindings are IP addresses that have been automatically mapped to MAC addresses of hosts that are found in the DHCP database. Because the bindings are stored in the volatile memory of the DHCP server, binding information is lost in the event of power failures or on device reloads. To prevent the loss of automatic binding information, a copy of the automatic binding information is stored on a remote host called the DHCP database agent. The bindings are periodically written to the database agent. When the device reloads, the bindings are read from the database agent to the DHCP database in the DHCP server.



---

**Note** We strongly recommend that you use database agents. However, Cisco DHCP server can function even without database agents.

---

Some DHCP clients send a client identifier (DHCP option 61) in the DHCP packet. To configure manual bindings for such clients, you must enter the **client-identifier** command with the hexadecimal values that identify the DHCP client. To configure manual bindings for clients that do not send a client identifier option, you must enter the **hardware-address** DHCP pool configuration command with the hexadecimal hardware address of the client.

Depending on your release, the DHCP server sends infinite lease time to the clients for which manual bindings are configured.

Depending on your release, the DHCP server sends lease time that is configured using the **lease** command to clients for which manual bindings are configured.



---

**Note** You cannot configure manual bindings within the same pool that is configured with the **network** command in DHCP pool configuration mode. See the [Configuring DHCP Address Pools](#) section for information about DHCP address pools and the **network** command.

---

### SUMMARY STEPS

1. **enable**
2. **configure terminal**
3. **ip dhcp pool** *pool-name*
4. **host** *address* [*mask* | */prefix-length*]
5. **client-identifier** *unique-identifier*
6. **hardware-address** *hardware-address* [*protocol-type* | *hardware-number*]
7. **client-name** *name*
8. **end**

## DETAILED STEPS

	Command or Action	Purpose
<b>Step 1</b>	<b>enable</b> <b>Example:</b> Device> enable	Enables privileged EXEC mode. <ul style="list-style-type: none"> <li>• Enter your password if prompted.</li> </ul>
<b>Step 2</b>	<b>configure terminal</b> <b>Example:</b> Device# configure terminal	Enters global configuration mode.
<b>Step 3</b>	<b>ip dhcp pool <i>pool-name</i></b> <b>Example:</b> Device(config)# ip dhcp pool pool1	Creates a name for the DHCP server address pool and enters DHCP pool configuration mode.
<b>Step 4</b>	<b>host <i>address [mask   /prefix-length]</i></b> <b>Example:</b> Device(dhcp-config)# host 172.16.0.1	Specifies the IP address and subnet mask of the client. <ul style="list-style-type: none"> <li>• There is no limit to the number of manual bindings you can configure. However, you can configure only one manual binding per host pool.</li> </ul>
<b>Step 5</b>	<b>client-identifier <i>unique-identifier</i></b> <b>Example:</b> Device(dhcp-config)# client-identifier 01b7.0813.8811.66	Specifies the unique identifier for DHCP clients. <ul style="list-style-type: none"> <li>• This command is used for DHCP requests.</li> <li>• DHCP clients require client identifiers. You can specify the unique identifier for the client in either of the following ways:               <ul style="list-style-type: none"> <li>• A 7-byte dotted hexadecimal notation. For example, 01b7.0813.8811.66, where 01 represents the Ethernet media type and the remaining bytes represent the MAC address of the DHCP client.</li> <li>• A 27-byte dotted hexadecimal notation. For example, 76566467228030324e39762302e333734312d4661302f31. The equivalent ASCII string for this hexadecimal value is vendor-0024.97b0.3741-fa0/1, where vendor represents the vendor, 0024.97b0.3741 represents the MAC address of the source interface, and fa0/1 represents the source interface of the DHCP client.</li> </ul> </li> <li>• See the Troubleshooting section for information about how to determine the client identifier of the DHCP client.</li> </ul>

	Command or Action	Purpose
		<p><b>Note</b> The identifier specified here is considered for a DHCP client that sends a client identifier in the packet.</p>
<b>Step 6</b>	<p><b>hardware-address</b> <i>hardware-address</i> [<i>protocol-type</i>   <i>hardware-number</i>]</p> <p><b>Example:</b></p> <pre>Device(dhcp-config) # hardware-address b708.1388.f166 ethernet</pre>	<p>Specifies a hardware address for the client.</p> <ul style="list-style-type: none"> <li>This command is used for BOOTP requests.</li> </ul> <p><b>Note</b> The hardware address specified here is considered for a DHCP client that does not send a client identifier in the packet.</p>
<b>Step 7</b>	<p><b>client-name</b> <i>name</i></p> <p><b>Example:</b></p> <pre>Device(dhcp-config) # client-name client1</pre>	<p>(Optional) Specifies the name of the client using any standard ASCII character.</p> <ul style="list-style-type: none"> <li>The client name should not include the domain name. For example, the name client1 should not be specified as client1.cisco.com.</li> </ul>
<b>Step 8</b>	<p><b>end</b></p> <p><b>Example:</b></p> <pre>Device(dhcp-config) # end</pre>	<p>Returns to privileged EXEC mode.</p>

## Troubleshooting Tips

Use the following command to debug any errors that you may encounter when you configure DHCP to automatically generate a unique ID:

- `debug ip dhcp server packets`

## Configuring DHCP Static Mapping

The DHCP Static Mapping feature enables the assignment of static IP addresses (without creating numerous host pools with manual bindings) by using a customer-created text file that the DHCP server reads. The benefit of this feature is that it eliminates the need for a long configuration file and reduces the space required in NVRAM to maintain address pools.

A DHCP database contains the mappings between a client IP address and the hardware address, which is referred to as a binding. There are two types of bindings: manual bindings that map a single hardware address to a single IP address, and automatic bindings that dynamically map a hardware address to an IP address from a pool of IP addresses. Manual (also known as static) bindings can be configured individually directly on the device or by using the DHCP Static Mapping feature. These static bindings can be read from a separate static mapping text file. The static mapping text files are read when a device reloads or the DHCP service restarts. These files are read-only.

The read static bindings are treated just like the manual bindings, in that they are:

- Retained across DHCPRELEASES from the clients.

- Not timed out.
- Deleted only upon deletion of the pool.
- Provided appropriate exclusions for the contained addresses, which are created at the time of the read.

Just like automatic bindings, manual (or static) bindings from the static mapping text file are also displayed by using the **show ip dhcp binding** command.

Perform this task to create the static mapping text file. You will input your addresses in the text file, which is stored in the DHCP database for the DHCP server to read. There is no limit to the number of addresses that can be stored in the file. The file format has the following elements:

- Database version number
- End-of-file designator
- Hardware type
- Hardware address
- IP address
- Lease expiration
- Time the file was created

See the following table for more details about the format of the text file.

The following is a sample static mapping text file:

```
*time* Jan 21 2005 03:52 PM
*version* 2
!IP address      Type      Hardware address      Lease expiration
10.0.0.4 /24     1         0090.bff6.081e        Infinite
10.0.0.5 /28     id        00b7.0813.88f1.66     Infinite
10.0.0.2 /21     1         0090.bff6.081d        Infinite
*end*
```

**Table 1: Static Mapping Text File Field Descriptions**

Field	Description
*time*	Specifies the time the file was created. This field allows DHCP to differentiate between the new and old database versions when multiple agents are configured. The valid format of the time is mm dd yyyy hh:mm AM/PM.
*version* 2	Specifies the database version number.
IP address	Specifies the static IP address. If the subnet mask is not specified, a mask is automatically assigned depending on the IP address. The IP address and the mask is separated by a space.
Type	Specifies the hardware type. For example, type “1” indicates Ethernet. The type “id” indicates that the field is a DHCP client identifier. Legal values can be found online at <a href="http://www.iana.org/assignments/arp-parameters">http://www.iana.org/assignments/arp-parameters</a> in the “Number Hardware Type” list.

Field	Description
Hardware address	<p>Specifies the hardware address.</p> <p>When the type is numeric, the type refers to the hardware media. Legal values can be found online at <a href="http://www.iana.org/assignments/arp-parameters">http://www.iana.org/assignments/arp-parameters</a> in the “Number Hardware Type” list.</p> <p>When the type is “id,” the type refers to a match on the client identifier.</p> <p>For more information about the client identifier, see RFC 2132, <i>DHCP Options and BOOTP Vendor Extensions</i>, section 9.14, located at <a href="http://www.ietf.org/rfc/rfc2132.txt">http://www.ietf.org/rfc/rfc2132.txt</a>, or the <b>client-identifier</b> command.</p> <p>If you are unsure about the client identifier to match with the hardware type, use the <b>debug dhcp detail</b> command to display the client identifier being sent to the DHCP server from the client.</p>
Lease expiration	Specifies the expiration of the lease. “Infinite” specifies that the duration of the lease is unlimited.
*end*	End of file. DHCP uses the *end* designator to detect file truncation.

## Configuring the DHCP Server to Read a Static Mapping Text File

### Before you begin

The administrator must create the static mapping text file in the correct format and configure the address pools before performing this task.

Before editing the file, you must disable the DHCP server using the **no service dhcp** command.



#### Note

The static bindings must not be deleted when a DHCPRELEASE is received or must not be timed out by the DHCP timer. The static bindings should be created by using the **ip dhcp pool** command.

### SUMMARY STEPS

1. **enable**
2. **configure terminal**
3. **ip dhcp pool** *name*
4. **origin file** *url*
5. **end**
6. **show ip dhcp binding** [*address*]

### DETAILED STEPS

	Command or Action	Purpose
Step 1	<b>enable</b> <b>Example:</b>	Enables privileged EXEC mode. <ul style="list-style-type: none"> <li>• Enter your password if prompted.</li> </ul>



	Command or Action	Purpose
	Device> enable	
<b>Step 2</b>	<b>configure terminal</b> <b>Example:</b>  Device# configure terminal	Enters global configuration mode.
<b>Step 3</b>	<b>ip dhcp pool name</b> <b>Example:</b>  Device(config)# ip dhcp pool pool1	Assigns a name to a DHCP pool and enters DHCP configuration mode.  <b>Note</b> If you have already configured the IP DHCP pool name using the <b>ip dhcp pool</b> command and the static file URL using the <b>origin file</b> command, you must perform a fresh read using the <b>no service dhcp</b> command and the <b>service dhcp</b> command.
<b>Step 4</b>	<b>origin file url</b> <b>Example:</b>  Device(dhcp-config)# origin file tftp://10.1.0.1/static-bindings	Specifies the URL that the DHCP server can access to locate the text file.
<b>Step 5</b>	<b>end</b> <b>Example:</b>  Device(dhcp-config)# end	Returns to privileged EXEC mode.
<b>Step 6</b>	<b>show ip dhcp binding [address]</b> <b>Example:</b>  Device# show ip dhcp binding	(Optional) Displays a list of all bindings created on a specific DHCP server.

### Examples

The following sample output from the **show ip dhcp binding** command displays address bindings that are configured:

```
Device# show ip dhcp binding

00:05:14:%SYS-5-CONFIG_I: Configured from console by console
Bindings from all pools not associated with VRF:
IP address Client-ID/          Ls expir   Type      Hw address          User name
10.9.9.4/8  0063.7363.2d30.3036.  Infinite   Static   302e.3762.2e39.3634.  632d.4574.8892.
10.9.9.1/24 0063.6973.636f.2d30.  Infinite   Static   3036.302e.3437.3165.  2e64.6462.342d.
```

The following sample output displays each entry in the static mapping text file:

```
*time* Jan 21 2005 22:52 PM
```

```

!IP address      Type      Hardware address      Lease expiration
10.19.9.1 /24    id        0063.6973.636f.2d30.3036.302e.3437
10.9.9.4         id        0063.7363.2d30.3036.302e.3762.2e39.3634.632d  Infinite
*end*

```

The following sample debug output shows the reading of the static mapping text file from the TFTP server:

```

Device# debug ip dhcp server

Loading abc/static_pool from 10.19.192.33 (via Ethernet0):
[OK - 333 bytes]
*May 26 23:14:21.259: DHCPD: contacting agent tftp://10.19.192.33/abc/static_pool (attempt
0)
*May 26 23:14:21.467: DHCPD: agent tftp://10.19.192.33/abc/static_pool is responding.
*May 26 23:14:21.467: DHCPD: IFS is ready.
*May 26 23:14:21.467: DHCPD: reading bindings from tftp://10.19.192.33/abc/static_pool.
*May 26 23:14:21.707: DHCPD: read 333 / 1024 bytes.
*May 26 23:14:21.707: DHCPD: parsing text line
*time* Apr 22 2002 11:31 AM
*May 26 23:14:21.707: DHCPD: parsing text line ""
*May 26 23:14:21.707: DHCPD: parsing text line
!IP address Type Hardware address Lease expiration
*May 26 23:14:21.707: DHCPD: parsing text line
"10.9.9.1 /24 id 0063.6973.636f.2d30.3036.302e.3437"
*May 26 23:14:21.707: DHCPD: creating binding for 10.9.9.1
*May 26 23:14:21.707: DHCPD: Adding binding to radix tree (10.9.9.1)
*May 26 23:14:21.707: DHCPD: Adding binding to hash tree
*May 26 23:14:21.707: DHCPD: parsing text line
"10.9.9.4 id 0063.7363.2d30.3036.302e.3762.2e39.3634.632d"
*May 26 23:14:21.711: DHCPD: creating binding for 10.9.9.4
*May 26 23:14:21.711: DHCPD: Adding binding to radix tree (10.9.9.4)
*May 26 23:14:21.711: DHCPD: Adding binding to hash tree
*May 26 23:14:21.711: DHCPD: parsing text line "Infinite"
*May 26 23:14:21.711: DHCPD: parsing text line ""
*May 26 23:14:21.711: DHCPD: parsing text line
!IP address Interface-index Lease expiration VRF
*May 26 23:14:21.711: DHCPD: parsing text line "*end*"
*May 26 23:14:21.711: DHCPD: read static bindings from tftp://10.19.192.33/abccomp/static_pool.

```

## Customizing DHCP Server Operation

By default, the DHCP server pings a pool address twice before assigning a particular address to a requesting client. If the ping is unanswered, the DHCP server assumes (with a high probability) that the address is not in use and assigns the address to the requesting client.

By default, the DHCP server waits for 2 seconds before timing out a ping packet.

You can configure the DHCP server to ignore and not reply to any BOOTP requests that the server receives. This functionality is beneficial when there is a mix of BOOTP and DHCP clients in a network segment and there is a BOOTP server and a Cisco DHCP server servicing the network segment. The BOOTP server is configured with static bindings for the BOOTP clients and the BOOTP clients must obtain their addresses from the BOOTP server. However, DHCP servers can also respond to BOOTP requests and the DHCP server may offer an address that causes the BOOTP clients to boot with the address from the DHCP server, instead of the address from the BOOTP server. Configuring the DHCP server to ignore BOOTP requests ensures that the BOOTP clients will receive address information from the BOOTP server and will not accept an address from a DHCP server.

Cisco software can forward these ignored BOOTP request packets to another DHCP server if the **ip helper-address** command is configured on the incoming interface.



**Note** It is not recommended to use DHCP ping checks on Cisco Catalyst switches implemented in switch stack or VSS.

## SUMMARY STEPS

1. **enable**
2. **configure terminal**
3. **ip dhcp ping packets** *number*
4. **ip dhcp ping timeout** *milliseconds*
5. **ip dhcp bootp ignore**
6. **end**

## DETAILED STEPS

	Command or Action	Purpose
Step 1	<b>enable</b> <b>Example:</b> Device> enable	Enables privileged EXEC mode. <ul style="list-style-type: none"> <li>• Enter your password if prompted.</li> </ul>
Step 2	<b>configure terminal</b> <b>Example:</b> Device# configure terminal	Enters global configuration mode.
Step 3	<b>ip dhcp ping packets</b> <i>number</i> <b>Example:</b> Device(config)# ip dhcp ping packets 5	(Optional) Specifies the number of ping packets the DHCP server sends to a pool address before assigning the address to a requesting client. <ul style="list-style-type: none"> <li>• The default is two packets. Setting the <i>number</i> argument to a value of 0 disables the DHCP server ping operation.</li> </ul>
Step 4	<b>ip dhcp ping timeout</b> <i>milliseconds</i> <b>Example:</b> Device(config)# ip dhcp ping timeout 850	(Optional) Specifies the duration the DHCP server waits for a ping reply from an address pool.
Step 5	<b>ip dhcp bootp ignore</b> <b>Example:</b> Device(config)# ip dhcp bootp ignore	(Optional) Allows the DHCP server to selectively ignore and not reply to received BOOTP requests. <ul style="list-style-type: none"> <li>• The <b>ip dhcp bootp ignore</b> command applies to all DHCP pools configured on the device. BOOTP requests cannot be selectively ignored on a per-DHCP pool basis.</li> </ul>

	Command or Action	Purpose
<b>Step 6</b>	<b>end</b> <b>Example:</b> Device(config)# end	Returns to privileged EXEC mode.

## Configuring a Remote Device to Import DHCP Server Options from a Central DHCP Server

The Cisco DHCP server can dynamically configure options such as the Domain Name System (DNS) and Windows Internet Name Service (WINS) addresses to respond to DHCP requests from local clients behind the customer premises equipment (CPE). Earlier, network administrators configured the Cisco DHCP server on each device manually. Now, the Cisco DHCP server is enhanced to allow configuration information to be updated automatically. Network administrators can configure one or more centralized DHCP servers to update specific DHCP options within the DHCP pools. The remote servers can request or “import” these option parameters from centralized servers.

This section contains the following tasks:

### Configuring the Central DHCP Server to Update DHCP Options

Perform the following task to configure the Central DHCP Server to update DHCP options:

#### SUMMARY STEPS

1. **enable**
2. **configure terminal**
3. **ip dhcp pool** *name*
4. **network** *network-number* [*mask* | *prefix-length*]
5. **dns-server** *address* [*address2* ... *address8*]
6. **end**

#### DETAILED STEPS

	Command or Action	Purpose
<b>Step 1</b>	<b>enable</b> <b>Example:</b> Device> enable	Enables privileged EXEC mode. <ul style="list-style-type: none"> <li>• Enter your password if prompted.</li> </ul>
<b>Step 2</b>	<b>configure terminal</b> <b>Example:</b> Device# configure terminal	Enters global configuration mode.
<b>Step 3</b>	<b>ip dhcp pool</b> <i>name</i> <b>Example:</b>	Creates a name for the DHCP server address pool and enters DHCP pool configuration mode.

	Command or Action	Purpose
	Device(config)# ip dhcp pool 1	
<b>Step 4</b>	<b>network</b> <i>network-number</i> [ <i>mask</i>   <i>/prefix-length</i> ] <b>Example:</b>  Device(dhcp-config)# network 172.16.0.0 /16	Specifies the subnet number and mask of the DHCP address pool.
<b>Step 5</b>	<b>dns-server</b> <i>address</i> [ <i>address2</i> ... <i>address8</i> ] <b>Example:</b>  Device(dhcp-config)# dns server 172.16.1.103 172.16.2.103	(Optional) Specifies the IP address of a DNS server that is available to a DHCP client. <ul style="list-style-type: none"> <li>• One IP address is required; however, you can specify up to eight IP addresses in one command line.</li> <li>• Servers should be listed in the order of preference.</li> </ul>
<b>Step 6</b>	<b>end</b> <b>Example:</b>  Device(dhcp-config)# end	Returns to privileged EXEC mode.

## Configuring the Remote Device to Import DHCP Options

Perform the following task to configure the remote device to import DHCP options:



**Note** When two servers provide DHCP addresses to a single device configured with **ip address dhcp** on two different interfaces, the imported information is merged and, for those options that take a single value, the last known option value will be used.

### SUMMARY STEPS

1. **enable**
2. **configure terminal**
3. **ip dhcp pool** *pool-name*
4. **network** *network-number* [*mask* | */prefix-length*]
5. **import** {**all** | **interface** *interface\_name*}
6. **exit**
7. **interface** *type number*
8. **ip address dhcp**
9. **end**
10. **show ip dhcp import**

### DETAILED STEPS

	Command or Action	Purpose
<b>Step 1</b>	<b>enable</b>	Enables privileged EXEC mode.

	Command or Action	Purpose
	<b>Example:</b> Device> enable	<ul style="list-style-type: none"> <li>• Enter your password if prompted.</li> </ul>
<b>Step 2</b>	<b>configure terminal</b> <b>Example:</b> Device# configure terminal	Enters global configuration mode.
<b>Step 3</b>	<b>ip dhcp pool <i>pool-name</i></b> <b>Example:</b> Device(config)# ip dhcp pool pool1	Creates a name for the DHCP server address pool and enters DHCP pool configuration mode.
<b>Step 4</b>	<b>network <i>network-number</i> [<i>mask</i>   <i>/prefix-length</i>]</b> <b>Example:</b> Device(dhcp-config)# network 172.30.0.0 /16	Specifies the subnet network number and mask of the DHCP address pool.
<b>Step 5</b>	<b>import {all   interface <i>interface_name</i>}</b> <b>Example:</b> Device(dhcp-config)# import all Device(dhcp-config) # import interface Ethernet0/0	Imports DHCP option parameters into the DHCP server database.
<b>Step 6</b>	<b>exit</b> <b>Example:</b> Device(dhcp-config)# exit	Exits DHCP pool configuration mode and enters global configuration mode.
<b>Step 7</b>	<b>interface <i>type number</i></b> <b>Example:</b> Device(config)# interface FastEthernet 0/0	Configures an interface and enters interface configuration mode.
<b>Step 8</b>	<b>ip address dhcp</b> <b>Example:</b> Device(config-if)# ip address dhcp	Specifies that the interface acquires an IP address through DHCP.
<b>Step 9</b>	<b>end</b> <b>Example:</b> Device(config-if)# end	Returns to privileged EXEC mode.
<b>Step 10</b>	<b>show ip dhcp import</b> <b>Example:</b>	Displays the options that are imported from the central DHCP server.

	Command or Action	Purpose
	Device# show ip dhcp import	

## Configuring DHCP Address Allocation Using Option 82

### Restrictions for DHCP Address Allocation Using Option 82

If the relay agent inserts option 82 but does not set the giaddr field in the DHCP packet, the DHCP server interface must be configured as a trusted interface by using the **ip dhcp relay information trusted** global configuration command. This configuration prevents the server from dropping the DHCP message.

### Enabling Option 82 for DHCP Address Allocation

By default, the Cisco DHCP server uses information provided by option 82 to allocate IP addresses. If the DHCP address allocation is disabled, perform the task described in this section to reenale this capability.

#### SUMMARY STEPS

1. **enable**
2. **configure terminal**
3. **ip dhcp use class**
4. **end**

#### DETAILED STEPS

	Command or Action	Purpose
<b>Step 1</b>	<b>enable</b> <b>Example:</b> Device> enable	Enables privileged EXEC mode. <ul style="list-style-type: none"> <li>• Enter your password if prompted.</li> </ul>
<b>Step 2</b>	<b>configure terminal</b> <b>Example:</b> Device# configure terminal	Enters global configuration mode.
<b>Step 3</b>	<b>ip dhcp use class</b> <b>Example:</b> Device(config)# ip dhcp use class	Controls DHCP classes that are used for address allocation. <ul style="list-style-type: none"> <li>• This functionality is enabled by default.</li> <li>• Use the <b>no</b> form of this command to disable this functionality without deleting the DHCP class configuration.</li> </ul>
<b>Step 4</b>	<b>end</b> <b>Example:</b> Device(config)# end	Returns to privileged EXEC mode.

## Troubleshooting Tips

If DHCP classes are configured in the pool, but the DHCP server does not use the classes, verify if the **no ip dhcp use class** command was configured.

## Defining the DHCP Class and Relay Agent Information Patterns

### Before you begin

You must know the hexadecimal value of each byte location in option 82 to configure the **relay-information hex** command. The option 82 format may vary from product to product. Contact the relay agent vendor for this information.

Perform this task to define the DHCP class and relay agent information patterns:

### SUMMARY STEPS

1. **enable**
2. **configure terminal**
3. **ip dhcp class** *class-name*
4. **relay agent information**
5. **relay-information hex** *pattern* [\*] [**bitmask** *mask*]
6. Repeat Steps 3 through 5 for each DHCP class you need to configure.
7. **end**

### DETAILED STEPS

	Command or Action	Purpose
<b>Step 1</b>	<b>enable</b> <b>Example:</b>  Device> enable	Enables privileged EXEC mode.  • Enter your password if prompted.
<b>Step 2</b>	<b>configure terminal</b> <b>Example:</b>  Device# configure terminal	Enters global configuration mode.
<b>Step 3</b>	<b>ip dhcp class</b> <i>class-name</i> <b>Example:</b>  Device(config)# ip dhcp class CLASS1	Defines a DHCP class and enters DHCP class configuration mode.
<b>Step 4</b>	<b>relay agent information</b> <b>Example:</b>  Device(dhcp-class)# relay agent information	Enters relay agent information option configuration mode.  • If you omit this step, the DHCP class matches any relay agent information option, whether the relay agent information option value is available or not.



	Command or Action	Purpose
<b>Step 5</b>	<b>relay-information hex <i>pattern</i> [*] [<i>bitmask mask</i>]</b> <b>Example:</b>  <pre>Device(dhcp-class-relayinfo)# relay-information hex 01030a0b0c02050000000123</pre>	(Optional) Specifies a hexadecimal value for full relay information option. <ul style="list-style-type: none"> <li>• The <i>pattern</i> argument creates a pattern that is used to match the DHCP class.</li> <li>• If you omit this step, no pattern is configured and it is considered a match to any relay agent information option value, but the relay information option must be available in the DHCP packet.</li> <li>• You can configure multiple <b>relay-information hex</b> commands in a DHCP class.</li> </ul>
<b>Step 6</b>	Repeat Steps 3 through 5 for each DHCP class you need to configure.	
<b>Step 7</b>	<b>end</b> <b>Example:</b>  <pre>Device(dhcp-class-relayinfo)# end</pre>	Returns to privileged EXEC mode.

## Troubleshooting Tips

If DHCP classes are configured in the pool, but the DHCP server does not use the classes, verify if the **no ip dhcp use class** command was configured.

## Defining the DHCP Address Pool

Perform this task to define the DHCP address pool:

### SUMMARY STEPS

1. **enable**
2. **configure terminal**
3. **ip dhcp pool *name***
4. **network *network-number* [*mask* | *prefix-length*]**
5. **class *class-name***
6. **address range *start-ip end-ip***
7. Repeat Steps 5 and 6 for each DHCP class you need to associate with the DHCP pool.
8. **end**

### DETAILED STEPS

	Command or Action	Purpose
<b>Step 1</b>	<b>enable</b> <b>Example:</b>	Enables privileged EXEC mode. <ul style="list-style-type: none"> <li>• Enter your password if prompted.</li> </ul>

	Command or Action	Purpose
	Device> enable	
<b>Step 2</b>	<b>configure terminal</b> <b>Example:</b> Device# configure terminal	Enters global configuration mode.
<b>Step 3</b>	<b>ip dhcp pool name</b> <b>Example:</b> Device# ip dhcp pool ABC	Configures a DHCP address pool on a Cisco IOS DHCP server and enters DHCP pool configuration mode. <ul style="list-style-type: none"> <li>Multiple pools can be configured with the same class, eliminating the need to configure the same pattern in multiple pools.</li> </ul>
<b>Step 4</b>	<b>network network-number [mask   /prefix-length]</b> <b>Example:</b> Device(dhcp-config)# network 10.0.20.0	Configures the subnet and mask for a DHCP address pool on a Cisco IOS DHCP server.
<b>Step 5</b>	<b>class class-name</b> <b>Example:</b> Device(dhcp-config)# class CLASS1	Associates a class with a pool and enters DHCP pool class configuration mode. <ul style="list-style-type: none"> <li>This command also creates a DHCP class if the DHCP class is not yet defined.</li> </ul>
<b>Step 6</b>	<b>address range start-ip end-ip</b> <b>Example:</b> Device(dhcp-pool-class)# address range 10.0.20.1 10.0.20.100	(Optional) Sets an address range for the DHCP class in a DHCP server address pool. <ul style="list-style-type: none"> <li>If this command is not configured for a class, the default value is the entire subnet of the pool. Each class in the DHCP pool is examined for a match in the order configured.</li> </ul>
<b>Step 7</b>	Repeat Steps 5 and 6 for each DHCP class you need to associate with the DHCP pool.	
<b>Step 8</b>	<b>end</b> <b>Example:</b> Device(dhcp-pool-class)# end	Returns to privileged EXEC mode.

## Configuring a Static Route with the Next-Hop Dynamically Obtained Through DHCP

Perform this task to configure a static route to use a DHCP default gateway as the next-hop router.

This task enables static routes to be assigned using a DHCP default gateway as the next-hop router. This behavior was not possible before the introduction of this feature because the gateway IP address is not known

until after the DHCP address assignment. A static route could not be configured with the command-line interface (CLI) that used that DHCP-supplied address.

The static routes are installed in the routing table when the default gateway is assigned by the DHCP server. The routes remain in the routing table until the DHCP lease expires at which time the routes are removed.

When a DHCP client releases an address, the corresponding static route (the route configured with the **ip route** command) is automatically removed from the routing table. If the DHCP router option (option 3 of the DHCP packet) changes during the client renewal, the DHCP default gateway changes to the new IP address supplied in the renewal.

This feature is particularly useful for VPN deployments such as Dynamic Multipoint VPNs (DMVPNs). This feature is useful when a non-physical interface like a multipoint generic routing encapsulation (mGRE) tunnel is configured on the router and certain traffic needs to be excluded from going to the tunnel interface.

### Before you begin

Verify all DHCP client and server configuration steps. Ensure that the DHCP client and server are properly defined to supply a DHCP router option 3.



#### Note

- If the DHCP client is not able to obtain an IP address or default router IP address, the static route is not installed in the routing table.
- If the lease has expired and the DHCP client cannot renew the address, the DHCP IP address assigned to the client is released and any associated static routes are removed from the routing table.

## SUMMARY STEPS

1. **enable**
2. **configure terminal**
3. **ip route** *prefix mask {ip-address | interface-type interface-number [ip-address]}* **dhcp** [*distance*]
4. **end**
5. **show ip route**

## DETAILED STEPS

	Command or Action	Purpose
Step 1	<b>enable</b> <b>Example:</b> Device> enable	Enables privileged EXEC mode. <ul style="list-style-type: none"> <li>• Enter your password if prompted.</li> </ul>
Step 2	<b>configure terminal</b> <b>Example:</b> Device# configure terminal	Enters global configuration mode.
Step 3	<b>ip route</b> <i>prefix mask {ip-address   interface-type interface-number [ip-address]}</i> <b>dhcp</b> [ <i>distance</i> ] <b>Example:</b>	Assigns a static route for the default next-hop router when the DHCP server is accessed for an IP address.

	Command or Action	Purpose
	<pre>Device(config)# ip route 209.165.200.225 255.255.255.255 GigabitEthernet 0/0/0 dhcp</pre> <p><b>Example:</b></p> <pre>Device(config)# ip route 209.165.200.226 255.255.255.255 GigabitEthernet 0/0/1 dhcp 20</pre>	<ul style="list-style-type: none"> <li>If more than one interface on a router is configured to obtain an IP address from a DHCP server, use the <b>ip route prefix mask interface-type interface-number dhcp</b> command for each interface. If the interface is not specified, the route is added to the routing table as soon as any of the interfaces obtain an IP address and default router.</li> </ul>
<b>Step 4</b>	<p><b>end</b></p> <p><b>Example:</b></p> <pre>Device(config)# end</pre>	Returns to global configuration mode.
<b>Step 5</b>	<p><b>show ip route</b></p> <p><b>Example:</b></p> <pre>Device# show ip route</pre>	<p>(Optional) Displays the current state of the routing table.</p> <ul style="list-style-type: none"> <li>Use this command to display assigned static routes once the DHCP client obtains an address and a default router address from the DHCP server.</li> </ul>

## Clearing DHCP Server Variables

Perform this task to clear DHCP server variables:

### SUMMARY STEPS

1. **enable**
2. **clear ip dhcp binding {address | \*}**
3. **clear ip dhcp conflict {address | \*}**
4. **clear ip dhcp server statistics**

### DETAILED STEPS

	Command or Action	Purpose
<b>Step 1</b>	<p><b>enable</b></p> <p><b>Example:</b></p> <pre>Device&gt; enable</pre>	<p>Enables privileged EXEC mode.</p> <ul style="list-style-type: none"> <li>Enter your password if prompted.</li> </ul>
<b>Step 2</b>	<p><b>clear ip dhcp binding {address   *}</b></p> <p><b>Example:</b></p> <pre>Device# clear ip dhcp binding *</pre>	<p>Deletes an automatic address binding from the DHCP database.</p> <ul style="list-style-type: none"> <li>Specifying the <i>address</i> argument clears the automatic binding for a specific (client) IP address, whereas specifying an asterisk (*) clears all automatic bindings.</li> </ul>
<b>Step 3</b>	<p><b>clear ip dhcp conflict {address   *}</b></p> <p><b>Example:</b></p>	Clears an address conflict from the DHCP database.

	Command or Action	Purpose
	Device# clear ip dhcp conflict 172.16.1.103	<ul style="list-style-type: none"> <li>Specifying the <i>address</i> argument clears the conflict for a specific IP address, whereas specifying an asterisk (*) clears conflicts for all addresses.</li> </ul>
<b>Step 4</b>	<b>clear ip dhcp server statistics</b>  <b>Example:</b>  Device# clear ip dhcp server statistics	Resets all DHCP server counters to 0.

## Configuration Examples for the Cisco IOS XE DHCP Server

### Example: Configuring the DHCP Database Agent

The following example shows how to store bindings on host 172.16.4.253. The file transfer protocol is FTP. The server waits for 2 minutes (120 seconds) before performing database changes.

```
ip dhcp database ftp://user:password@172.16.4.253/router-dhcp write-delay 120
```

### Example: Excluding IP Addresses

In the following example, server A and server B service the subnet 10.0.20.0/24. If the subnet is split equally between the two servers, server A is configured to allocate IP addresses 10.0.20.1 to 10.0.20.125 and server B is configured to allocate IP addresses 10.0.20.126 to 10.0.20.254.

#### Server A

```
ip dhcp excluded-address 10.0.20.126 10.0.20.255
!
ip dhcp pool A
 network 10.0.20.0 255.255.255.0
```

#### Server B

```
ip dhcp excluded-address 10.0.20.0 10.0.20.125
!
ip dhcp pool B
 network 10.0.20.0 255.255.255.0
```

### Example: Configuring DHCP Address Pools

In the following example, three DHCP address pools are created: one in network 172.16.0.0, one in subnetwork 172.16.1.0, and one in subnetwork 172.16.2.0. Attributes from network 172.16.0.0—such as the domain name, Domain Name System (DNS) server, (Network Basic Input/Output System) NetBIOS name server, and NetBIOS node type—are inherited in subnetworks 172.16.1.0 and 172.16.2.0. In each pool, clients are granted 30-day leases and all addresses in each subnetwork, except the excluded addresses, are available to the DHCP

server for assigning to clients. The table below lists the IP addresses for the devices in three DHCP address pools.

**Table 2: DHCP Address Pool Configuration**

Pool 0 (Network 172.16.0.0)	Pool 1 (Subnetwork 172.16.1.0)	Pool 2 (Subnetwork 172.16.2.0)			
Device	IP Address	Device	IP Address	Device	IP Address
Default devices	—	Default devices	172.16.1.100 172.16.1.101	Default devices	172.16.2.100 172.16.2.101
DNS server	172.16.1.102 172.16.2.102	—	—	—	—
NetBIOS name server	172.16.1.103 172.16.2.103	—	—	—	—
NetBIOS node type	h-node	—	—	—	—

```
ip dhcp database ftp://user:password@172.16.4.253/router-dhcp write-delay 120
ip dhcp excluded-address 172.16.1.100 172.16.1.103
ip dhcp excluded-address 172.16.2.100 172.16.2.103
!
ip dhcp pool 0
 network 172.16.0.0 /16
 domain-name cisco.com
 dns-server 172.16.1.102 172.16.2.102
 netbios-name-server 172.16.1.103 172.16.2.103
 netbios-node-type h-node
!
ip dhcp pool 1
 network 172.16.1.0 /24
 default-router 172.16.1.100 172.16.1.101
 lease 30
!
ip dhcp pool 2
 network 172.16.2.0 /24
 default-router 172.16.2.100 172.16.2.101
 lease 30
```

The following example shows how to configure DHCP pool to support RegEx feature:

```
!
ip dhcp pool test
 network 192.168.10.0 255.255.255.0
 default-router 192.168.10.1
 dns-server 40.0.0.100
 class cisco_devices
  address range 192.168.10.2 192.168.10.100
!
class smart_phones
  address range 192.168.10.101 192.168.10.220
!
!
ip dhcp class cisco_devices
 option 60 cisco_string -----<this is option 60 VCI string, exact match>
```

```

!
ip dhcp class smart_phones
 option 60 smartphone* -----<option 60 VCI string, regex match>
!

```

The following example shows how to configure DHCP server class:

```

Router#
Router# conf t
Enter configuration commands, one per line. End with CNTL/Z.
Router(config)#ip dhcp class HATHWAY_STB
Router(config-dhcp-class)#?
DHCP class configuration commands:
  exit      Exit from DHCP class configuration mode
  no        Negate a command or set its defaults
  option    Raw DHCP options
  relay     Enter relay agent information option configuration submode
  remark    Specify a remark for this class

Router(config-dhcp-class)#option ?
<0-254> DHCP option code

Router(config-dhcp-class)#option 60 ?
  hex      Specify hex value of the option
  WORD     Specify a regular expression string

Router(config-dhcp-class)#option 60 stb* ?
<cr>

```

The following example shows how to Import options learnt on specific interface to LAN side DHCP pool:

```

!
ip dhcp pool LAN_Pool
import interface Ethernet0/0
!

Router#
Router# configure terminal
Enter configuration commands, one per line. End with CNTL/Z.

Router(config)# ip dhcp pool pc_pool
Router(dhcp-config)# import ?
  all          all DHCP options
  interface    Select an interface to import options
Router(dhcp-config)# import interface Ethernet0/1

```

## Example: Configuring a DHCP Address Pool with Multiple Disjoint Subnets

Multiple disjoint subnets in a DHCP pool can be used in any of the following network topologies:

- IP address pooling—The DHCP client and server reside on the same subnet.
- DHCP relay—The DHCP client and DHCP server communicate through a DHCP relay agent where the relay interface is configured with secondary IP addresses.
- Hierarchical DHCP—The DHCP server is configured as the DHCP subnet allocation server. The DHCP client and DHCP subnet allocation server communicate through an on-demand address pool (ODAP) router.

In the following example, one DHCP address pool named pool3 is created; the primary subnet is 172.16.0.0/16, one secondary subnet is 172.16.1.0/24, and the other secondary subnet is 172.16.2.0/24.

### Example: Configuring a DHCP Address Pool with Multiple Disjoint Subnets

- When IP addresses in the primary subnet are exhausted, the DHCP server inspects the secondary subnets in the order in which the subnets were added to the pool.
- When the DHCP server allocates an IP address from the secondary subnet 172.16.1.0/24, the server uses the subnet-specific default device list that consists of IP addresses 172.16.1.100 and 172.16.1.101. However, when the DHCP server allocates an IP address from the subnet 172.16.2.0/24, the server uses the pool-wide list that consists of the four IP addresses from 172.16.0.100 to 172.16.0.103.
- Other attributes from the primary subnet 172.16.0.0/16—such as the domain name, DNS server, NetBIOS name server, and NetBIOS node type—are inherited in both the secondary subnets.
- DHCP clients are granted 30-day leases on IP addresses in the pool. All addresses in each subnet, except the excluded addresses, are available to the DHCP server for assigning to clients.

The table below lists the IP addresses for the devices in the DHCP address pool that consists of three disjoint subnets.

**Table 3: DHCP Address Pool Configuration with Multiple Disjoint Subnets**

Primary Subnet (172.16.0.0/16)	First Secondary Subnet (172.16.1.0/24)	Second Secondary Subnet (172.16.2.0/24)			
Device	IP Address	Device	IP Address	Device	IP Address
Default devices	172.16.0.100 172.16.0.101 172.16.0.102 172.16.0.103	Default devices	172.16.1.100 172.16.1.101	Default devices	172.16.0.100 172.16.0.101 172.16.0.102 172.16.0.103
DNS server	172.16.1.102 172.16.2.102	—	—	—	—
NetBIOS name server	172.16.1.103 172.16.2.103	—	—	—	—
NetBIOS node type	h-node	—	—	—	—

```
ip dhcp database ftp://user:password@172.16.4.253/router-dhcp write-delay 120
ip dhcp excluded-address 172.16.0.100 172.16.1.103
ip dhcp excluded-address 172.16.1.100 172.16.1.101
!
ip dhcp pool pool3
network 172.16.0.0 /16
default-router 172.16.0.100 172.16.2.101 172.16.0.102 172.16.0.103
domain-name cisco.com
dns-server 172.16.1.102 172.16.2.102
netbios-name-server 172.16.1.103 172.16.2.103
netbios-node-type h-node
lease 30
!
network 172.16.1.0 /24 secondary
override default-router 172.16.1.100 172.16.1.101
end
```



```
!
network 172.16.2.0 /24 secondary
```

## Configuring Manual Bindings Example

The following example shows how to create a manual binding for a client named Mars.cisco.com. The MAC address of the client is 02c7.f800.0422 and the IP address of the client is 172.16.2.254.

```
ip dhcp pool Mars
 host 172.16.2.254
 hardware-address 02c7.f800.0422 ieee802
 client-name Mars
```

Because attributes are inherited, the previous configuration is equivalent to the following:

```
ip dhcp pool Mars
 host 172.16.2.254 mask 255.255.255.0
 hardware-address 02c7.f800.0422 ieee802
 client-name Mars
 default-router 172.16.2.100 172.16.2.101
 domain-name cisco.com
 dns-server 172.16.1.102 172.16.2.102
 netbios-name-server 172.16.1.103 172.16.2.103
 netbios-node-type h-node
```

## Example: Configuring Static Mapping

The following example shows how to restart the DHCP server, configure the pool, and specify the URL where the static mapping text file is stored:

```
no service dhcp
service dhcp
ip dhcp pool abcpool

origin file tftp://10.1.0.1/staticfilename
```



---

**Note** The static mapping text file can be copied to flash memory on the device and served by the TFTP process of the device. In this case, the IP address in the original file line must be an address owned by the device and one additional line of configuration is required on the device: **tftp-server flash static-filename**.

---

## Importing DHCP Options Example

The following example shows a remote and central server configured to support the importing of DHCP options. The central server is configured to automatically update DHCP options, such as DNS and WINS addresses, within the DHCP pools. In response to a DHCP request from a local client behind CPE equipment, the remote server can request or “import” these option parameters from the centralized server. See the figure below for a diagram of the network topology.

Figure 1: DHCP Example Network Topology

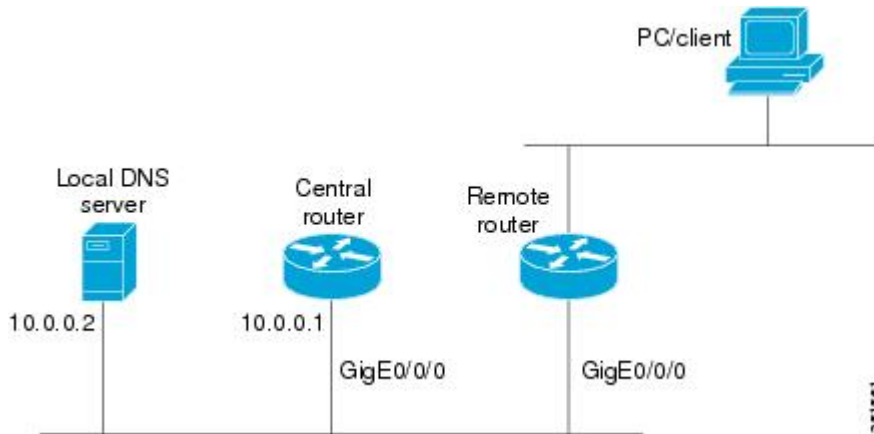

### Central Router

```
!do not assign this range to DHCP clients
ip dhcp-excluded address 10.0.0.1 10.0.0.5
!
ip dhcp pool central
! Specifies network number and mask for DHCP clients
network 10.0.0.0 255.255.255.0
! Specifies the domain name for the client
domain-name central
! Specifies DNS server that will respond to DHCP clients when they need to correlate host
! name to ip address
dns-server 10.0.0.2
! Specifies the NETBIOS WINS server
netbios-name-server 10.0.0.2
!
interface GigabitEthernet0/0/0
ip address 10.0.0.1 255.255.255.0
duplex auto
speed auto
```

### Remote Router

```
ip dhcp pool client
! Imports DHCP option parameters into DHCP server database
import all
network 20.0.0.0 255.255.255.0
!
interface GigabitEthernet0/0/0
ip address dhcp
duplex auto
speed auto
```

## Configuring DHCP Address Allocation Using Option 82 Example

This example configures two DHCP classes. CLASS1 defines the group of DHCP clients whose address requests contain the relay agent information option with the specified hexadecimal values. CLASS2 defines the group of DHCP clients whose address requests contain the configured relay agent information suboptions.

CLASS3 has no pattern configured and is treated as a “match to any” class. This type of class is useful for specifying a “default” class.

In the following example, the subnet of pool ABC has been divided into three ranges without further subnetting of the 10.0.20.0/24 subnet. If there is a DHCP Discover message from the 10.0.20.0/24 subnet with option 82 matching that of class CLASS1, an available address in the range from 10.0.20.1 to 10.0.20.100 will be allocated. If there is no free address in CLASS1's address range, the DHCP Discover message will be matched against CLASS2, and so on.

Thus, each class in the DHCP pool will be examined for a match in the order configured by the user. In pool ABC, the order of matching is CLASS1, CLASS2, and finally CLASS3. In pool DEF, class CLASS2 does not have any address range configured. By default, the address range for a particular class is the pool's entire subnet(s). Therefore, clients matching CLASS2 may be allocated addresses from 11.0.20.1 to 11.0.20.254.

Multiple pools can be configured with the same class, eliminating the need to configure the same patterns in multiple pools. In the future, further classification method may be implemented. For example, there may be a need to specify that one or more pools should only be used to service a particular class of devices (for example, cable modems and IP phones).

```
! Defines the DHCP classes and relay information patterns
ip dhcp class CLASS1
  relay agent information
    relay-information hex 01030a0b0c02050000000123
    relay-information hex 01030a0b0c02*
    relay-information hex 01030a0b0c02050000000000 bitmask 000000000000000000000000FF
ip dhcp class CLASS2
  relay agent information
    relay-information hex 01040102030402020102
    relay-information hex 01040101030402020102
ip dhcp class CLASS3
  relay agent information
! Associates the DHCP pool with DHCP classes
ip dhcp pool ABC
  network 10.0.20.0 255.255.255.0
  class CLASS1
    address range 10.0.20.1 10.0.20.100
  class CLASS2
    address range 10.0.20.101 10.0.20.200
  class CLASS3
    address range 10.0.20.201 10.0.20.254
ip dhcp pool DEF
  network 11.0.20.0 255.255.255.0
  class CLASS1
    address range 11.0.20.1 11.0.20.64
  class CLASS2
```

## Configuring a Static Route with the Next-Hop Dynamically Obtained Through DHCP Example

The following example shows how to configure two GigabitEthernet interfaces to obtain the next-hop router IP address from the DHCP server:

```
ip route 10.10.10.0 255.255.255.0 dhcp 200
ip route 10.10.20.1 255.255.255.255 gigaether 1 dhcp
```

# Additional References

## Related Documents

Related Topic	Document Title
Cisco IOS Commands	<a href="#">Cisco IOS Master Command List, All Releases</a>
DHCP commands: complete command syntax, command mode, command history, defaults, usage guidelines, and examples	<a href="#">Cisco IOS IP Addressing Services Command Reference</a>
DHCP conceptual information	“DHCP Overview” module
DHCP relay agent configuration	“Configuring the Cisco IOS XE DHCP Relay Agent” module
DHCP client configuration	“Configuring the Cisco IOS XE DHCP Client” module
DHCP On-Demand Address Pool Manager	“Configuring the DHCP On-Demand Address Pool Manager” module

## Standards and RFCs

Standard/RFC	Title
RFC 951	<i>Bootstrap Protocol (BOOTP)</i>
RFC 1542	<i>Clarifications and Extensions for the Bootstrap Protocol</i>
RFC 2131	<i>Dynamic Host Configuration Protocol</i>
RFC 2132	<i>DHCP Options and BOOTP Vendor Extensions</i>

## Technical Assistance

Description	Link
<p>The Cisco Support website provides extensive online resources, including documentation and tools for troubleshooting and resolving technical issues with Cisco products and technologies.</p> <p>To receive security and technical information about your products, you can subscribe to various services, such as the Product Alert Tool (accessed from Field Notices), the Cisco Technical Services Newsletter, and Really Simple Syndication (RSS) Feeds.</p> <p>Access to most tools on the Cisco Support website requires a Cisco.com user ID and password.</p>	<a href="http://www.cisco.com/techsupport">http://www.cisco.com/techsupport</a>

## Feature Information for the Cisco IOS XE DHCP Server

The following table provides release information about the feature or features described in this module. This table lists only the software release that introduced support for a given feature in a given software release train. Unless noted otherwise, subsequent releases of that software release train also support that feature.

Use Cisco Feature Navigator to find information about platform support and Cisco software image support. To access Cisco Feature Navigator, go to [www.cisco.com/go/cfn](http://www.cisco.com/go/cfn). An account on Cisco.com is not required.

**Table 4: Feature Information for the Cisco IOS XE DHCP Server**

Feature Name	Releases	Feature Configuration Information
DHCP Server	Cisco IOS XE Release 2.1 Cisco IOS XE Release 3.9S	Cisco routers running Cisco IOS XE software include Dynamic Host Configuration Protocol (DHCP) server and relay agent software. The Cisco IOS XE DHCP server is a full DHCP server implementation that assigns and manages IP addresses from specified address pools within the router to DHCP clients. The DHCP server can be configured to assign additional parameters such as the IP address of the domain name system (DNS) server and the default router.
DHCP Address Allocation Using Option 82	Cisco IOS XE Release 2.1 Cisco IOS XE Release 3.9S	The Cisco IOS XE DHCP server can allocate dynamic IP addresses based on the relay information option (option 82) information sent by the relay agent.  The following commands were introduced by this feature: <b>address range, class, ip dhcp class, ip dhcp use class, relay agent information, relay-information hex.</b>
DHCP Statically Configured Routes Using a DHCP Gateway	Cisco IOS XE Release 2.1 Cisco IOS XE Release 3.9S	This feature enables the configuration of static routes that point to an assigned DHCP next hop router.  The following commands were modified by this feature: <b>ip route, show ip route.</b>
DHCP Server Options - Import and Autoconfiguration	Cisco IOS XE Release 2.3 Cisco IOS XE Release 3.9S	Options imported by multiple subsystems can co-exist in the DHCP address pool. When the session is terminated or the lease is released, the imported options are cleared.
DHCP Server Multiple Subnet	12.4(15)T 12.2(33)SRB 15.3(1)S Cisco IOS XE Release 3.2SE Cisco IOS XE Release 3.9S	The DHCP Server Multiple Subnet feature enables multiple subnets to be configured under the same DHCP address pool.  The following commands were introduced or modified: <b>network(DHCP), override default-router.</b>

Feature Name	Releases	Feature Configuration Information
DHCP Static Mapping	Cisco IOS XE Release 3.9S	Configuring static mapping pools enables the DHCP server to read the static bindings from a separate text file (similar in format to the DHCP database file) that is stored in special pools.  The following commands were introduced or modified: <b>origin.</b>
DHCP Server Import All Enhancement	Cisco IOS XE Release 3.9S	The DHCP Server Import All Enhancement feature is an enhancement to the <b>import all</b> command. Prior to this feature, the options imported through the <b>import all</b> command were overwritten by those imported by another subsystem. Through this feature, options imported by multiple subsystems can coexist in the DHCP address pool. When the session is terminated or the lease is released, the imported options are cleared.
DHCPv4 Client options	Cisco IOS XE Fuji Release 16.9.1	The following features are supported on Cisco 4000 Series ISRs: <ul style="list-style-type: none"> <li>• Regular Expression support for options 60, 77, 124 and 125</li> <li>• Generic support to configure all applicable client DHCP options</li> <li>• Import options learnt on specific interface to DHCP pool</li> <li>• Longest Match support for option 60, 77, 124 and 125</li> </ul>



## CHAPTER 3

# Configuring the DHCP Server On-Demand Address Pool Manager

---

The Cisco IOS XE DHCP server on-demand address pool (ODAP) manager is used to centralize the management of large pools of addresses and simplify the configuration of large networks. ODAP provides a central management point for the allocation and assignment of IP addresses. When a Cisco IOS XE router is configured as an ODAP manager, pools of IP addresses are dynamically increased or reduced in size depending on the address utilization level. A DHCP pool configured in the router can also be used as an IP address pooling mechanism. The IP address pooling mechanism is configured in the router to specify the source of IP addresses for PPP peers.

- [Finding Feature Information, on page 49](#)
- [Prerequisites for Configuring the DHCP Server On-Demand Address Pool Manager, on page 50](#)
- [Restrictions for Configuring the DHCP Server On-Demand Address Pool Manager, on page 50](#)
- [Information About the DHCP Server On-Demand Address Pool Manager, on page 50](#)
- [How to Configure the DHCP Server On-Demand Address Pool Manager, on page 53](#)
- [How to Configure DHCP ODAP Subnet Allocation Server Support, on page 66](#)
- [Configuration Examples for DHCP Server On-Demand Address Pool Manager, on page 73](#)
- [Additional References, on page 80](#)
- [Feature Information for the DHCP Server On-Demand Address Pool Manager, on page 81](#)
- [Glossary, on page 82](#)

## Finding Feature Information

Your software release may not support all the features documented in this module. For the latest caveats and feature information, see [Bug Search Tool](#) and the release notes for your platform and software release. To find information about the features documented in this module, and to see a list of the releases in which each feature is supported, see the feature information table.

Use Cisco Feature Navigator to find information about platform support and Cisco software image support. To access Cisco Feature Navigator, go to [www.cisco.com/go/cfn](http://www.cisco.com/go/cfn). An account on Cisco.com is not required.

## Prerequisites for Configuring the DHCP Server On-Demand Address Pool Manager

Before you configure the ODAP manager, you should understand the concepts documented in the “DHCP Overview” module.

You must configure standard Multiprotocol Label Switching (MPLS) Virtual Private Networks (VPNs) unless you intend to use non-MPLS VPNs.

In order for the IP address pooling mechanism to work correctly, the VPN routing and forwarding instance (VRF) of the PPP session must match that configured on the pool. Typically this matching is done either by configuring the **ip vrf forwarding** *vrf-name* command on the virtual template interface, or if AAA is used to authorize the PPP user, it can be part of the user’s profile configuration.



---

**Note** For a default session, you can apply access interface VRF and VRF service simultaneously.

---

## Restrictions for Configuring the DHCP Server On-Demand Address Pool Manager

- The **ip dhcp excluded-address** global configuration command cannot be used to exclude addresses from VRF associated pools.
- The **vrf** DHCP pool configuration command is currently not supported for host pools.
- Attribute inheritance is not supported on VRF pools.
- A router can be configured as a subnet allocation server and a DHCP server at the same time with one restriction: separate pools must be created for subnet allocation and IP address assignment. An address pool cannot be used by DHCP for both subnet allocation and IP address assignment.

## Information About the DHCP Server On-Demand Address Pool Manager

### ODAP Manager Operation

ODAPs enable pools of IP addresses to be dynamically increased or reduced in size depending on the address utilization level. Once configured, the ODAP is populated with one or more subnets leased from a source server and is ready to serve address requests from DHCP clients or from PPP sessions. The source server can be a remote DHCP server or a RADIUS server (via AAA). Currently, only the Cisco Access Registrar RADIUS server supports ODAPs. Subnets can be added to the pool when a certain utilization level (high utilization mark) is achieved. When the utilization level falls below a certain level (low utilization mark), a subnet can



be returned to the server from which it was originally leased. Summarized routes for each leased subnet must be inserted or removed from the related VRF with each addition or removal of subnets into the ODAP.

ODAPs support address assignment using DHCP for customers using private addresses such as in MPLS VPNs. VPNs allow the possibility that two pools in separate networks can have the same address space, with private network addresses, served by the same DHCP server. These IP addresses can be distinguished by a VPN identifier to help select the VPN to which the client belongs.

Each ODAP is configured and associated with a particular MPLS VPN. Cisco IOS XE software also supports non-MPLS VPN address pools by adding pool name support to the **peer default ip address dhcp-pool pool-name** command.

For MPLS VPNs, each VPN is associated with one or more VRFs. The VRF is a key element in the VPN technology because it maintains the routing information that defines a customer VPN site. This customer site is attached to a provider edge (PE) router. A VRF consists of an IP routing table, a derived Cisco Express Forwarding (CEF) table, a set of interfaces that use the forwarding table, and a set of rules and routing protocol parameters that control the information that is included in the routing table.

A PPP session belonging to a specific VPN is only allocated an address from the ODAP associated with that VPN. These PPP sessions are terminated on a Virtual Home Gateway (VHG)/PE router where the ODAP is configured. The VHG/PE router maps the remote user to the corresponding MPLS VPNs.

For PPP sessions, individual address allocation from an ODAP follows a First Leased subnet First (FLF) policy. FLF searches for a free address beginning on the first leased subnet, followed by a search on the second leased subnet if no free address is available in the first subnet, and so on. This policy provides the benefit of grouping the leased addresses over time to a set of subnets, which allows an efficient subnet release and route summarization.

However, the FLF policy differs from the normal DHCP address selection policy. Normal DHCP address selection takes into account the IP address of the receiving interface or the gateway address if it is nonzero. To support both policies, the DHCP server needs to be able to distinguish between a normal DHCP address request and an address request for a PPP client. The ODAP manager uses an IP address pooling mechanism for PPP that allows the DHCP server to distinguish between a normal DHCP address request and a request from a PPP client.

Subnet release from an ODAP follows a Last Leased subnet First (LLF) policy, which prefers the last leased subnet to be released first. This LLF policy searches for a releasable subnet (a subnet with no addresses currently being leased) starting with the last leased subnet. If a releasable subnet is found (candidate subnet), it is released, and the summarized route for that subnet is removed. If more than one releasable subnet exists at that time, only the most recently allocated is released. If there are no releasable subnets, no action is taken. If by releasing the candidate subnet, the high utilization mark is reached, the subnet is not released. The first leased subnet is never released (regardless of the instantaneous utilization level) until the ODAP is disabled.

When a DHCP pool receives multiple subnets from an upstream DHCP server, an address from each subnet is automatically configured on the client connected interface so that the addresses within the subnets can be requested by DHCP clients.

The first address in the first subnet is automatically assigned to the primary address on the interface. The first address of each subsequent subnet is assigned to secondary addresses on the interface. In addition, as client addresses are reclaimed, the count of lease addresses for that subnet is decremented. Once a lease counter for a subnet reaches zero (that is, lease expiry), the subnet is returned to the pool. The previous address on the interface is removed and the first secondary address on the interface is promoted as the primary address of the interface.

The figure below shows an ODAP manager configured on the Cisco IOS XE DHCP server. The ODAP requests an initial pool from the AAA server. Clients make DHCP requests and the DHCP server fulfills

requests from the pool. When the utilization rate meets 90 percent, the ODAP manager requests an expansion and the AAA server allocates another subnet from which the ODAP manager can allocate addresses.

**Figure 2: ODAP Address Pool Management for MPLS VPNs**

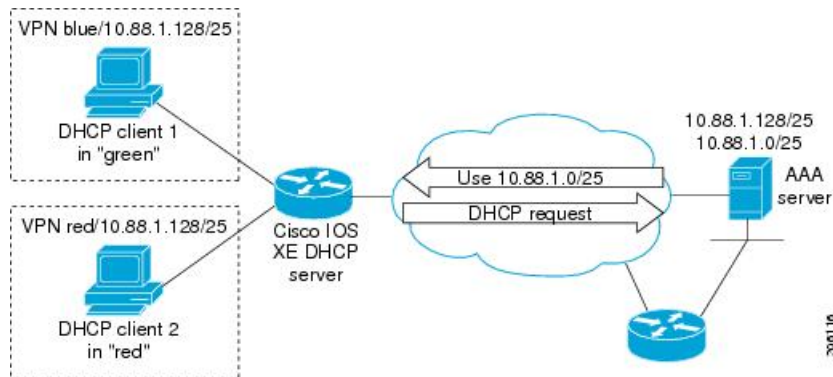

## Subnet Allocation Server Operation

You can also configure the ODAP manager to allocate subnets instead of individual IP addresses.

This capability allows the network operator to configure a Cisco IOS XE router as a subnet allocation server. The operation of a subnet allocation server is similar to the operation of a DHCP server, except that pools of subnets are created and assigned instead of pools of IP addresses. Subnet allocation pools are created and configured by using the **subnet prefix-length** command in DHCP pool configuration mode. The size of each assigned or allocated subnet is set by the *prefix-length* argument, using standard Common InterDomain Routing (CIDR) bit count notation to determine the number of addresses that are configured in each subnet lease.

When a DHCP server is configured as a subnet allocation server, it provides subnet allocation pools for ODAP manager allocation. In the figure below, Router B is the subnet allocation server and allocates subnets to the ODAP manager based on the demand for IP addresses and subnet availability. Router B is configured to allocate an initial amount of address space in the form of subnets to the ODAP manager. The size of the subnet allocated by the ODAP manager is determined by the subnet size that is configured on the subnet allocation server. The ODAP manager will then assign addresses to clients from these subnets and allocate more subnets as the need for address space increases.

**Figure 3: Subnet Allocation Server Topology**



When the ODAP manager allocates a subnet, the subnet allocation server creates a subnet binding. This binding is stored in the DHCP database for as long as the ODAP manager requires the address space. The binding is removed and the subnet is returned to the subnet pool only when the ODAP manager releases the subnet as address space utilization decreases.

The subnet allocation server can also be associated with a VRF. A VRF consists of an IP routing table, a derived CEF table, a set of interfaces that use the forwarding table, and a set of rules and routing protocol parameters that control the information that is included in the routing table.

## Benefits of Using ODAPs

### Efficient Address Management

The ODAP manager allows customers to optimize their use of IP addresses, thus conserving address space.

### Efficient Route Summarization and Update

The ODAP manager inserts a summarized route when a subnet is added to the ODAP.

### Multiple VRF and Independent Private Addressing Support

The ODAP manager automatically injects subnet routing information into the appropriate VRF.

# How to Configure the DHCP Server On-Demand Address Pool Manager

## Defining DHCP ODAPs as the Global Default Mechanism

Perform this task to specify that the global default mechanism to use is on-demand address pooling.

IP addressing allows configuration of a global default address pooling mechanism. The DHCP server needs to be able to distinguish between a normal DHCP address request and an address request for a PPP client.

### SUMMARY STEPS

1. `enable`
2. `configure terminal`
3. `ip address-pool dhcp-pool`

### DETAILED STEPS

	Command or Action	Purpose
Step 1	<b>enable</b> <b>Example:</b> Router> enable	Enables privileged EXEC mode. <ul style="list-style-type: none"> <li>• Enter your password if prompted.</li> </ul>
Step 2	<b>configure terminal</b> <b>Example:</b> Router# configure terminal	Enters global configuration mode.
Step 3	<b>ip address-pool dhcp-pool</b> <b>Example:</b>	Enables on-demand address pooling as the global default IP address mechanism.

	Command or Action	Purpose
	<code>Router(config)# ip address-pool dhcp-pool</code>	<ul style="list-style-type: none"> <li>For remote access (PPP) sessions into MPLS VPNs, IP addresses are obtained from locally configured VRF-associated DHCP pools.</li> </ul>

## Defining DHCP ODAPs on an Interface

Perform this task to configure on-demand address pools on an interface.

The interface on-demand address pooling configuration overrides the global default mechanism on that interface.

### SUMMARY STEPS

1. `enable`
2. `configure terminal`
3. `interface type number`
4. `peer default ip address dhcp-pool [pool-name]`

### DETAILED STEPS

	Command or Action	Purpose
<b>Step 1</b>	<b>enable</b> <b>Example:</b> <code>Router&gt; enable</code>	Enables privileged EXEC mode. <ul style="list-style-type: none"> <li>Enter your password if prompted.</li> </ul>
<b>Step 2</b>	<b>configure terminal</b> <b>Example:</b> <code>Router# configure terminal</code>	Enters global configuration mode.
<b>Step 3</b>	<b>interface type number</b> <b>Example:</b> <code>Router(config)# interface Virtual-Templatel</code>	Specifies the interface and enters interface configuration mode.
<b>Step 4</b>	<b>peer default ip address dhcp-pool [pool-name]</b> <b>Example:</b> <code>Router(config-if)# peer default ip address dhcp-pool mypool</code>	Specifies an IP address from an on-demand address pool to be returned to a remote peer connecting to this interface. <ul style="list-style-type: none"> <li>The <i>pool-name</i> argument supports non-MPLS VPNs and is mandatory if the session is not associated with any VRF. Multiple pool names can be accepted but must be separated by white space.</li> </ul>

## Configuring the DHCP Pool as an ODAP

Perform this task to configure a DHCP address pool as an ODAP pool.

### SUMMARY STEPS

1. **enable**
2. **configure terminal**
3. **ip dhcp pool *pool-name***
4. **vrf *name***
5. **origin {dhcp | aaa | ipcp} [subnet size initial *size* [autogrow *size*]]**
6. **utilization mark low *percentage-number***
7. **utilization mark high *percentage-number***
8. **end**
9. **show ip dhcp pool [*pool-name*]**

### DETAILED STEPS

	Command or Action	Purpose
Step 1	<b>enable</b> <b>Example:</b>  Router> enable	Enables privileged EXEC mode.  • Enter your password if prompted.
Step 2	<b>configure terminal</b> <b>Example:</b>  Router# configure terminal	Enters global configuration mode.
Step 3	<b>ip dhcp pool <i>pool-name</i></b> <b>Example:</b>  Router(config)# ip dhcp pool red-pool	Configures a DHCP address pool on a Cisco IOS XE DHCP server and enters DHCP pool configuration mode.
Step 4	<b>vrf <i>name</i></b> <b>Example:</b>  Router(dhcp-config)# vrf red	(Optional) Associates the address pool with a VRF name.  • Only use this command for MPLS VPNs.
Step 5	<b>origin {dhcp   aaa   ipcp} [subnet size initial <i>size</i> [autogrow <i>size</i>]]</b> <b>Example:</b>  Router(dhcp-config)# origin dhcp subnet size initial /16 autogrow /16	Configures an address pool as an on-demand address pool.  • If you do not configure the pool as an autogrow pool, the pool will not request additional subnets if one subnet is already in the pool.  • You can enter size as either the subnet mask (nnnn.nnnn.nnnn.nnnn) or prefix size (/nn). The valid values are /0 and /4 to /30.

	Command or Action	Purpose
		<ul style="list-style-type: none"> <li>When a DHCP pool receives multiple subnets from an upstream DHCP server, an address from each subnet is automatically configured on the client connected interface so that the addresses within the subnets can be requested by DHCP clients. The first address in the first subnet is automatically assigned to the primary address on the interface. The first address of each subsequent subnet is assigned to secondary addresses on the interface. In addition, as client addresses are reclaimed, the count of lease addresses for that subnet is decremented. Once a lease counter for a subnet reaches zero (that is, lease expiry), the subnet is returned to the pool. The previous address on the interface is removed and the first secondary address on the interface is promoted as the primary address of the interface.</li> <li>If the <b>origin aaa</b> option is configured, AAA must be configured.</li> </ul>
<b>Step 6</b>	<p><b>utilization mark low</b> <i>percentage-number</i></p> <p><b>Example:</b></p> <pre>Router(dhcp-config)# utilization mark low 40</pre>	<p>Sets the low utilization mark of the pool size.</p> <ul style="list-style-type: none"> <li>This command cannot be used unless the <b>autogrow size</b> option of the <b>origin</b> command is configured.</li> <li>The default value is 0 percent.</li> </ul>
<b>Step 7</b>	<p><b>utilization mark high</b> <i>percentage-number</i></p> <p><b>Example:</b></p> <pre>Router(dhcp-config)# utilization mark high 60</pre>	<p>Sets the high utilization mark of the pool size.</p> <ul style="list-style-type: none"> <li>This command cannot be used unless the <b>autogrow size</b> option of the <b>origin</b> command is configured.</li> <li>The default value is 100 percent.</li> </ul>
<b>Step 8</b>	<p><b>end</b></p> <p><b>Example:</b></p> <pre>Router(dhcp-config)# end</pre>	<p>Returns to global configuration mode.</p>
<b>Step 9</b>	<p><b>show ip dhcp pool</b> [<i>pool-name</i>]</p> <p><b>Example:</b></p> <pre>Router# show ip dhcp pool</pre>	<p>(Optional) Displays information about DHCP address pools.</p> <ul style="list-style-type: none"> <li>Information about the primary and secondary interface address assignment is also displayed.</li> </ul>

## Configuring ODAPs to Obtain Subnets Through IPCP Negotiation

Perform this task to configure your router to use subnets obtained through IP Control Protocol (IPCP) negotiation.

You can assign IP address pools to customer premises equipment (CPE) devices, which, in turn, assign IP addresses to the CPE and to a DHCP pool. This functionality has three requirements:

- The Cisco IOS XE CPE device must be able to request and use the subnet.
- The RADIUS server (via AAA) must be able to provide that subnet and insert the framed route into the proper VRF table.
- The PE router must be able to facilitate providing the subnet through (IPCP) negotiation.

## SUMMARY STEPS

1. **enable**
2. **configure terminal**
3. **ip dhcp pool** *pool-name*
4. **import** {**all** | **interface** *interface\_name*}
5. **origin ipcp**
6. **exit**
7. **interface** *type number*
8. **ip address pool** *pool-name*

## DETAILED STEPS

	Command or Action	Purpose
Step 1	<b>enable</b> <b>Example:</b> Router> enable	Enables privileged EXEC mode. <ul style="list-style-type: none"> <li>• Enter your password if prompted.</li> </ul>
Step 2	<b>configure terminal</b> <b>Example:</b> Router# configure terminal	Enters global configuration mode.
Step 3	<b>ip dhcp pool</b> <i>pool-name</i> <b>Example:</b> Router(config)# ip dhcp pool red-pool	Configures a DHCP address pool on a Cisco IOS XE DHCP server and enters DHCP pool configuration mode.
Step 4	<b>import</b> { <b>all</b>   <b>interface</b> <i>interface_name</i> } <b>Example:</b> Device(dhcp-config)# import all Device(dhcp-config) # import interface Ethernet0/0	Imports DHCP option parameters into the DHCP server database.
Step 5	<b>origin ipcp</b> <b>Example:</b> Router(dhcp-config)# origin ipcp	Configures an address pool as an on-demand address pool using IPCP as the subnet allocation protocol.

	Command or Action	Purpose
<b>Step 6</b>	<b>exit</b> <b>Example:</b> Router(dhcp-config)# exit	Exits DHCP pool configuration mode.
<b>Step 7</b>	<b>interface</b> <i>type number</i> <b>Example:</b> Router(config)# interface GigabitEthernet 0/0/0	Specifies the interface and enters interface configuration mode.
<b>Step 8</b>	<b>ip address pool</b> <i>pool-name</i> <b>Example:</b> Router(config-if)# ip address pool red-pool	Specifies that the interface IP address will be automatically configured from the named pool, when the pool is populated with a subnet from IPCP.

## Configuring AAA

Perform this task to configure AAA.

To allow ODAP to obtain subnets from the AAA server, the AAA client must be configured on the VHG/PE router.

### SUMMARY STEPS

1. **enable**
2. **configure terminal**
3. **aaa new-model**
4. **aaa authorization configuration default group radius**
5. Do one of the following:
  - **aaa accounting network default start-stop group radius**
  - or
  - **aaa accounting network default stop-only group radius**
6. **aaa session-id common**

### DETAILED STEPS

	Command or Action	Purpose
<b>Step 1</b>	<b>enable</b> <b>Example:</b> Router> enable	Enables privileged EXEC mode. <ul style="list-style-type: none"> <li>• Enter your password if prompted.</li> </ul>
<b>Step 2</b>	<b>configure terminal</b> <b>Example:</b>	Enters global configuration mode.



	Command or Action	Purpose
	Router# configure terminal	
<b>Step 3</b>	<b>aaa new-model</b> <b>Example:</b> Router(config)# aaa new-model	Enables AAA access control.
<b>Step 4</b>	<b>aaa authorization configuration default group radius</b> <b>Example:</b> Router(config)# aaa authorization configuration default group radius	Downloads static route configuration information from the AAA server using RADIUS.
<b>Step 5</b>	Do one of the following: <ul style="list-style-type: none"> <li>• <b>aaa accounting network default start-stop group radius</b></li> <li>• or</li> <li>• <b>aaa accounting network default stop-only group radius</b></li> </ul> <b>Example:</b> Router(config)# aaa accounting network default start-stop group radius  <b>Example:</b> Router(config)# aaa accounting network default stop-only group radius	Enables AAA accounting of requested services for billing or security purposes when you use RADIUS. Sends a “start” accounting notice at the beginning of a process.  or  Enables AAA accounting of requested services for billing or security purposes when you use RADIUS. Sends a “stop” accounting notice at the end of the requested user process.
<b>Step 6</b>	<b>aaa session-id common</b> <b>Example:</b> Router(config)# aaa session-id common	Ensures that the same session ID will be used for each AAA accounting service type within a call.

## Configuring RADIUS

### ODAP AAA Profile

The AAA server sends the RADIUS Cisco AV pair attributes “pool-addr” and “pool-mask” to the Cisco IOS XE DHCP server in the access request and access accept. The pool-addr attribute is the IP address and the pool-mask attribute is the network mask (for example, pool-addr=192.168.1.0 and pool-mask=255.255.0.0). Together, these attributes make up a network address (address/mask) that is allocated by the AAA server to the Cisco IOS XE DHCP server.

## SUMMARY STEPS

1. **enable**
2. **configure terminal**
3. **ip radius source-interface** *subinterface-name*
4. **radius-server host** *ip-address* **auth-port** *port-number* **acct-port** *port-number*
5. **radius server attribute 32 include-in-access-req**
6. **radius server attribute 44 include-in-access-req**
7. **radius-server vsa send accounting**
8. **radius-server vsa send authentication**

## DETAILED STEPS

	Command or Action	Purpose
<b>Step 1</b>	<b>enable</b> <b>Example:</b> <pre>Router&gt; enable</pre>	Enables privileged EXEC mode. <ul style="list-style-type: none"> <li>• Enter your password if prompted.</li> </ul>
<b>Step 2</b>	<b>configure terminal</b> <b>Example:</b> <pre>Router# configure terminal</pre>	Enters global configuration mode.
<b>Step 3</b>	<b>ip radius source-interface</b> <i>subinterface-name</i> <b>Example:</b> <pre>Router(config)# ip radius source-interface GigabitEthernet0/0/0</pre>	Forces RADIUS to use the IP address of a specified interface for all outgoing RADIUS packets.
<b>Step 4</b>	<b>radius-server host</b> <i>ip-address</i> <b>auth-port</b> <i>port-number</i> <b>acct-port</b> <i>port-number</i> <b>Example:</b> <pre>Router(config)# radius-server host 172.16.1.1 auth-port 1645 acct-port 1646</pre>	Specifies a RADIUS server host. <ul style="list-style-type: none"> <li>• The <i>ip-address</i> argument specifies the IP address of the RADIUS server host.</li> </ul>
<b>Step 5</b>	<b>radius server attribute 32 include-in-access-req</b> <b>Example:</b> <pre>Router(config)# radius server attribute 32 include-in-access-req</pre>	Sends RADIUS attribute 32 (NAS-Identifier) in an access request or accounting request.
<b>Step 6</b>	<b>radius server attribute 44 include-in-access-req</b> <b>Example:</b>	Sends RADIUS attribute 44 (Accounting Session ID) in an access request or accounting request.

	Command or Action	Purpose
	<pre>Router(config)# radius server attribute 44 include-in-access-req</pre>	
<b>Step 7</b>	<p><b>radius-server vsa send accounting</b></p> <p><b>Example:</b></p> <pre>Router(config)# radius-server vsa send accounting</pre>	Configures the network access server (NAS) to recognize and use vendor-specific accounting attributes.
<b>Step 8</b>	<p><b>radius-server vsa send authentication</b></p> <p><b>Example:</b></p> <pre>Router(config)# radius-server vsa send authentication</pre>	Configures the NAS to recognize and use vendor-specific authentication attributes.

### What to do next

## Disabling ODAPs

This task shows how to disable an ODAP from a DHCP pool.

When an ODAP is disabled, all leased subnets are released. If active PPP sessions are using addresses from the released subnets, those sessions will be reset. DHCP clients leasing addresses from the released subnets will not be able to renew their leases.

### SUMMARY STEPS

1. **enable**
2. **configure terminal**
3. **ip dhcp pool *pool-name***
4. **no origin {dhcp|aaa|ipcp}**

### DETAILED STEPS

	Command or Action	Purpose
<b>Step 1</b>	<p><b>enable</b></p> <p><b>Example:</b></p> <pre>Router&gt; enable</pre>	Enables privileged EXEC mode. <ul style="list-style-type: none"> <li>• Enter your password if prompted.</li> </ul>
<b>Step 2</b>	<p><b>configure terminal</b></p> <p><b>Example:</b></p> <pre>Router# configure terminal</pre>	Enters global configuration mode.

	Command or Action	Purpose
Step 3	<b>ip dhcp pool</b> <i>pool-name</i> <b>Example:</b> <pre>Router(config)# ip dhcp pool red-pool</pre>	Configures a DHCP address pool on a Cisco IOS XE DHCP server and enters DHCP pool configuration mode.
Step 4	<b>no origin</b> { <b>dhcp aaa ipcp</b> } <b>Example:</b> <pre>Router(dhcp-config)# no origin dhcp</pre>	Disables the ODAP.

## Verifying ODAP Operation

Perform this task to verify ODAP operation.

### SUMMARY STEPS

1. **enable**
2. **show ip dhcp pool** [*pool-name*] The following output is for two DHCP pools: Green and Global. Pool Green is configured with a high utilization mark of 50 and a low utilization mark of 30. The pool is also configured to obtain more subnets when the high utilization mark is reached (autogrow). The Subnet size field indicates the values configured in the **origin** command as the initial and incremental subnet sizes that would be requested by the pool named Green. The Total addresses field is a count of all the usable addresses in the pool. The Leased addresses field is a total count of how many bindings were created from the pool. The Pending event field shows subnet request, which means that a subnet request is pending for the pool. The subnet request was scheduled because the Leased addresses count has exceeded the high utilization level of the pool. Subnets currently added to pool Green are shown in sequence. The Current index column shows the address that would be allocated next from this subnet. The IP address range column shows the range of usable addresses from the subnet. The Leased addresses column shows individual count of bindings created from each subnet. Three subnets are currently added to pool Green. The first two subnets have used all their addresses and thus the Current index is showing 0.0.0.0. Notice that pool Green and pool Global can have the same subnet (172.16.0.1-172.16.0.6) because pool Green is configured to be in VRF Green, while pool Global is configured to be in the global address space.
3. **show ip dhcp binding** The following output shows the bindings from pool Green. The Type field shows On-demand, which indicates that the address binding was created for a PPP session. The Lease expiration field shows Infinite, which means that the binding is valid as long as the session is up. If a subnet must be released back to the leasing server while the session is still up, the session is reset so that it will be forced to obtain a new IP address. The Hardware address column for an On-demand entry shows the identifier for the session as detected by PPP. There are no bindings shown under the Bindings from all pools not associated with VRF field because the Global pool has not allocated any addresses.

### DETAILED STEPS

- 
- Step 1**    **enable**
- Enables privileged EXEC mode. Enter your password if prompted.
- Example:**

```
Router> enable
```

**Step 2** **show ip dhcp pool** [*pool-name*] The following output is for two DHCP pools: Green and Global. Pool Green is configured with a high utilization mark of 50 and a low utilization mark of 30. The pool is also configured to obtain more subnets when the high utilization mark is reached (autogrow). The Subnet size field indicates the values configured in the **origin** command as the initial and incremental subnet sizes that would be requested by the pool named Green. The Total addresses field is a count of all the usable addresses in the pool. The Leased addresses field is a total count of how many bindings were created from the pool. The Pending event field shows subnet request, which means that a subnet request is pending for the pool. The subnet request was scheduled because the Leased addresses count has exceeded the high utilization level of the pool. Subnets currently added to pool Green are shown in sequence. The Current index column shows the address that would be allocated next from this subnet. The IP address range column shows the range of usable addresses from the subnet. The Leased addresses column shows individual count of bindings created from each subnet. Three subnets are currently added to pool Green. The first two subnets have used all their addresses and thus the Current index is showing 0.0.0.0. Notice that pool Green and pool Global can have the same subnet (172.16.0.1-172.16.0.6) because pool Green is configured to be in VRF Green, while pool Global is configured to be in the global address space.

**Example:**

```
Router# show ip dhcp pool
Pool Green :
Utilization mark (high/low)      : 50 / 30
Subnet size (first/next)         : 24 / 24 (autogrow)
VRF name                          : Green
Total addresses                  : 18
Leased addresses                 : 13
Pending event                    : subnet request
3 subnets are currently in the pool :
Current index      IP address range      Leased addresses
0.0.0.0           172.16.0.1 - 172.16.0.6           6
0.0.0.0           172.16.0.9 - 172.16.0.14          6
172.16.0.18      172.16.0.17 - 172.16.0.22         1
Pool Global :
Utilization mark (high/low)      : 100 / 0
Subnet size (first/next)         : 24 / 24 (autogrow)
Total addresses                  : 6
Leased addresses                 : 0
Pending event                    : none
1 subnet is currently in the pool :
Current index      IP address range      Leased addresses
172.16.0.1         172.16.0.1 - 172.16.0.6           0
```

**Step 3** **show ip dhcp binding** The following output shows the bindings from pool Green. The Type field shows On-demand, which indicates that the address binding was created for a PPP session. The Lease expiration field shows Infinite, which means that the binding is valid as long as the session is up. If a subnet must be released back to the leasing server while the session is still up, the session is reset so that it will be forced to obtain a new IP address. The Hardware address column for an On-demand entry shows the identifier for the session as detected by PPP. There are no bindings shown under the Bindings from all pools not associated with VRF field because the Global pool has not allocated any addresses.

**Example:**

```
Router# show ip dhcp binding

Bindings from all pools not associated with VRF:
IP address      Hardware address      Lease expiration      Type
Bindings from VRF pool Green:
IP address      Hardware address      Lease expiration      Type
172.16.0.1      5674.312d.7465.7374.  Infinite              On-demand
                2d38.3930.39
```

172.16.0.2	5674.312d.7465.7374. 2d38.3839.31	Infinite	On-demand
172.16.0.3	5674.312d.7465.7374. 2d36.3432.34	Infinite	On-demand
172.16.0.4	5674.312d.7465.7374. 2d38.3236.34	Infinite	On-demand
172.16.0.5	5674.312d.7465.7374. 2d34.3331.37	Infinite	On-demand
172.16.0.6	5674.312d.7465.7374. 2d37.3237.39	Infinite	On-demand
172.16.0.9	5674.312d.7465.7374. 2d39.3732.36	Infinite	On-demand
172.16.0.10	5674.312d.7465.7374. 2d31.3637	Infinite	On-demand
172.16.0.11	5674.312d.7465.7374. 2d39.3137.36	Infinite	On-demand
172.16.0.12	5674.312d.7465.7374. 2d37.3838.30	Infinite	On-demand
172.16.0.13	5674.312d.7465.7374. 2d32.3339.37	Infinite	On-demand
172.16.0.14	5674.312d.7465.7374. 2d31.3038.31	Infinite	On-demand
172.16.0.17	5674.312d.7465.7374. 2d38.3832.38	Infinite	On-demand
172.16.0.18	5674.312d.7465.7374. 2d32.3735.31	Infinite	On-demand

## Troubleshooting Tips

You can determine the client identifier by using the **debug ip dhcp server packet** command. In the following sample output, the client is identified by the value 0b07.1134.a029:

```
Device# debug ip dhcp server packet

DHCPD:DHCPDISCOVER received from client 0b07.1134.a029 through relay 10.1.0.253.
DHCPD:assigned IP address 10.1.0.3 to client 0b07.1134.a029.
.
.
.
```

## Monitoring and Maintaining the ODAP

This task shows how to monitor and maintain the ODAP.

Note the following behavior for the **clear ip dhcp binding**, **clear ip dhcp conflict**, and **clear ip dhcp subnet** commands:

- If you do not specify the **pool pool-name** option and an IP address is specified, it is assumed that the IP address is an address in the global address space and will look among all the non-VRF DHCP pools for the specified binding/conflict/subnet.
- If you do not specify the **pool pool-name** option and the \* option is specified, it is assumed that all automatic/ or on-demand bindings/conflicts/subnets in all VRF and non-VRF pools are to be deleted.
- If you specify both the **pool pool-name** option and the \* option, all automatic or on-demand bindings/conflicts/subnets in the specified pool only will be cleared.

- If you specify the **pool** *pool-name* option and an IP address, the specified binding/conflict or the subnet containing the specified IP address will be deleted from the specified pool.

## SUMMARY STEPS

1. **enable**
2. **clear ip dhcp [pool *pool-name*] binding {\* | *address*}**
3. **clear ip dhcp [pool *pool-name*] conflict {\* | *address*}**
4. **clear ip dhcp [pool *pool-name*] subnet{\*| *address*}**
5. **debug dhcp details**
6. **debug ip dhcp server events**
7. **show ip dhcp import**
8. **show ip interface [type number]**
9. **show ip dhcp pool *pool-name***

## DETAILED STEPS

	Command or Action	Purpose
<b>Step 1</b>	<b>enable</b> <b>Example:</b> Router> enable	Enables privileged EXEC mode. <ul style="list-style-type: none"> <li>• Enter your password if prompted.</li> </ul>
<b>Step 2</b>	<b>clear ip dhcp [pool <i>pool-name</i>] binding {*   <i>address</i>}</b> <b>Example:</b> Router# clear ip dhcp binding *	Deletes an automatic address binding or objects from a specific pool from the DHCP server database.
<b>Step 3</b>	<b>clear ip dhcp [pool <i>pool-name</i>] conflict {*   <i>address</i>}</b> <b>Example:</b> Router# clear ip dhcp conflict *	Clears an address conflict or conflicts from a specific pool from the DHCP server database.
<b>Step 4</b>	<b>clear ip dhcp [pool <i>pool-name</i>] subnet{*  <i>address</i>}</b> <b>Example:</b> Router# clear ip dhcp subnet *	Clears all currently leased subnets in the named DHCP pool or all DHCP pools if <i>name</i> is not specified.
<b>Step 5</b>	<b>debug dhcp details</b> <b>Example:</b> Router# debug dhcp details	Monitors the subnet allocation/releasing in the on-demand address pools.
<b>Step 6</b>	<b>debug ip dhcp server events</b> <b>Example:</b> Router# debug ip dhcp server events	Reports DHCP server events, like address assignments and database updates.

	Command or Action	Purpose
<b>Step 7</b>	<b>show ip dhcp import</b> <b>Example:</b> <pre>Router# show ip dhcp import</pre>	Displays the option parameters that were imported into the DHCP server database.
<b>Step 8</b>	<b>show ip interface</b> <i>[type number]</i> <b>Example:</b> <pre>Router# show ip interface</pre>	Displays the usability status of interfaces configured for IP.
<b>Step 9</b>	<b>show ip dhcp pool</b> <i>pool-name</i> <b>Example:</b> <pre>Router# show ip dhcp pool green</pre>	Displays DHCP address pool information.

# How to Configure DHCP ODAP Subnet Allocation Server Support

## Configuring a Global Pool on a Subnet Allocation Server

Perform this task to configure a global subnet pool on a subnet allocation server.

### Global Subnet Pools

Global subnet pools are created in a centralized network. The ODAP manager allocates subnets from the subnet allocation server based on subnet availability. When the ODAP manager allocates a subnet, the subnet allocation server creates a subnet binding. This binding is stored in the DHCP database for as long as the ODAP manager requires the address space. The binding is destroyed and the subnet is returned to the subnet pool only when the ODAP manager releases the subnet as address space utilization decreases.

### SUMMARY STEPS

1. **enable**
2. **configure terminal**
3. **ip dhcp pool** *pool-name*
4. **network** *network-number* [*mask* / *prefix-length*]
5. **subnet prefix-length** *prefix-length*

### DETAILED STEPS

	Command or Action	Purpose
<b>Step 1</b>	<b>enable</b> <b>Example:</b> <pre>Router&gt; enable</pre>	Enables privileged EXEC mode. <ul style="list-style-type: none"> <li>• Enter your password if prompted.</li> </ul>



	Command or Action	Purpose
Step 2	<b>configure terminal</b> <b>Example:</b> <pre>Router# configure terminal</pre>	Enters global configuration mode.
Step 3	<b>ip dhcp pool <i>pool-name</i></b> <b>Example:</b> <pre>Router(config)# ip dhcp pool GLOBAL-POOL</pre>	Enters DHCP pool configuration mode and specifies the subnet pool name.
Step 4	<b>network <i>network-number</i> [<i>mask</i> / <i>prefix-length</i>]</b> <b>Example:</b> <pre>Router(dhcp-config)# network 10.0.0.0 255.255.255.0</pre>	Configures the subnet number and mask for a DHCP address pool on a DHCP server. <ul style="list-style-type: none"> <li>The subnet mask or the prefix length can be configured in this step. The values that can be configured for the <i>prefix-length</i> argument follow CIDR bit count notation. The forward slash character must be used when configuring the <i>prefix-length</i> argument.</li> </ul>
Step 5	<b>subnet prefix-length <i>prefix-length</i></b> <b>Example:</b> <pre>Router(dhcp-config)# subnet prefix-length 8</pre>	Configures the subnet prefix length. The range of the <i>prefix-length</i> argument is from 1 to 31. <ul style="list-style-type: none"> <li>This command configures the number of IP addresses that each subnet is configured to allocate from the subnet pool. The values that can be configured for the <i>prefix-length</i> argument follow CIDR bit count notation format.</li> </ul>

## Configuring a VRF Subnet Pool on a Subnet Allocation Server

### VRF Subnet Pools

A subnet allocation server can be configured to assign subnets from VRF subnet allocation pools for MPLS VPN clients. VPN routes between the ODAP manager and the subnet allocation server are configured based on VRF name or VPN ID configuration. The VRF and VPN ID are configured to maintain routing information that defines customer VPN sites. The VPN customer site (or Customer Equipment [CE]) is attached to a provider edge (PE) router. The VRF is used to specify the VPN and consists of an IP routing table, a derived Cisco Express Forwarding (CEF) table, a set of interfaces that use the forwarding table, and a set of rules and routing protocol parameters that control the information that is included in the routing table.

#### Before you begin

The VRF name and VPN ID can be configured on the ODAP manager and subnet allocation server prior to the configuration of the subnet allocation pool.

### SUMMARY STEPS

1. enable

2. **configure terminal**
3. **ip dhcp pool** *pool-name*
4. **vrf** *vrf-name*
5. **network** *network-number* [*mask* /*prefix-length*]
6. **subnet** *prefix-length* *prefix-length*

## DETAILED STEPS

	Command or Action	Purpose
<b>Step 1</b>	<b>enable</b> <b>Example:</b> <pre>Router&gt; enable</pre>	Enables privileged EXEC mode. <ul style="list-style-type: none"> <li>• Enter your password if prompted.</li> </ul>
<b>Step 2</b>	<b>configure terminal</b> <b>Example:</b> <pre>Router# configure terminal</pre>	Enters global configuration mode.
<b>Step 3</b>	<b>ip dhcp pool</b> <i>pool-name</i> <b>Example:</b> <pre>Router(config)# ip dhcp pool VRF-POOL</pre>	Enters DHCP pool configuration mode and specifies the subnet pool name.
<b>Step 4</b>	<b>vrf</b> <i>vrf-name</i> <b>Example:</b> <pre>Router(dhcp-config)# vrf RED</pre>	Associates the on-demand address pool with a VPN routing and forwarding (VRF) instance name (or tag). <ul style="list-style-type: none"> <li>• The <b>vrf</b> keyword and <i>vrf-name</i> argument are used to specify the VPN for the VRF pool. The <i>vrf-name</i> argument must match the VRF name (or tag) that is configured for the client.</li> </ul>
<b>Step 5</b>	<b>network</b> <i>network-number</i> [ <i>mask</i> / <i>prefix-length</i> ] <b>Example:</b> <pre>Router(dhcp-config)# network 10.1.1.0 /24</pre>	Configures the subnet number and mask for a DHCP address pool on a Cisco IOS XE DHCP server. <ul style="list-style-type: none"> <li>• The subnet mask or the prefix length can be configured in this step. The values that can be configured for the <i>prefix-length</i> argument follow CIDR bit count notation. The forward slash character must be used when configuring the <i>prefix-length</i> argument.</li> </ul>
<b>Step 6</b>	<b>subnet</b> <i>prefix-length</i> <i>prefix-length</i> <b>Example:</b> <pre>Router(dhcp-config)# subnet prefix-length 16</pre>	Configures the subnet prefix length. The range of the <i>prefix-length</i> argument is from 1 to 31. <ul style="list-style-type: none"> <li>• This command configures the number of IP addresses that each subnet is configured to allocate from the subnet pool. The values that can be configured for the <i>prefix-length</i> argument follow CIDR bit count notation format.</li> </ul>

## Using a VPN ID to Configure a VRF Subnet Pool on a Subnet Allocation Server

Perform this task to configure a VRF subnet pool, using a VPN ID, on a subnet allocation server.

### VRF Pools and VPN IDs

A subnet allocation server can also be configured to assign subnets from VPN subnet allocation pools based on the VPN ID of a client. The VPN ID (or Organizational Unique Identifier [OUI]) is a unique identifier assigned by the IEEE.

#### Before you begin

The VRF name and VPN ID can be configured on the ODAP manager and subnet allocation server prior to the configuration of the subnet allocation pool.

### SUMMARY STEPS

1. **enable**
2. **configure terminal**
3. **ip vrf vrf-name**
4. **rd route-distinguisher**
5. **route-target both route-target-number**
6. **vpn id vpn-id**
7. **exit**
8. **ip dhcp pool pool-name**
9. **vrf vrf-name**
10. **network network-number [mask /prefix-length]**
11. **subnet prefix-length prefix-length**

### DETAILED STEPS

	Command or Action	Purpose
Step 1	<b>enable</b> <b>Example:</b> Router> enable	Enables privileged EXEC mode. <ul style="list-style-type: none"> <li>• Enter your password if prompted.</li> </ul>
Step 2	<b>configure terminal</b> <b>Example:</b> Router# configure terminal	Enters global configuration mode.
Step 3	<b>ip vrf vrf-name</b> <b>Example:</b> Router(config)#ip vrf RED	Creates a VRF routing table and specifies the VRF name (or tag). <ul style="list-style-type: none"> <li>• The <i>vrf-name</i> argument must match the VRF name that is configured for the client and VRF pool in Step 9.</li> </ul>

	Command or Action	Purpose
<b>Step 4</b>	<b>rd</b> <i>route-distinguisher</i> <b>Example:</b> <pre>Router(config-vrf)# rd 100:1</pre>	<p>Creates routing and forwarding tables for a VRF instance created in Step 3.</p> <ul style="list-style-type: none"> <li>There are two formats for configuring the route distinguisher argument. It can be configured in the as-number:network number (ASN:nn) format, as shown in the example, or it can be configured in the IP address:network number format (IP-address:nn).</li> </ul>
<b>Step 5</b>	<b>route-target both</b> <i>route-target-number</i> <b>Example:</b> <pre>Router(config-vrf)# route-target both 100:1</pre>	<p>Creates a route-target extended community for the VRF instance that was created in Step 3.</p> <ul style="list-style-type: none"> <li>The <b>both</b> keyword is used to specify which routes should be imported and exported to the target VPN extended community (or the ODAP manager in this configuration).</li> <li>The <i>route-target-number</i> argument follows the same format as the <i>route-distinguisher</i> argument in Step 4. These two arguments must match.</li> </ul>
<b>Step 6</b>	<b>vpn id</b> <i>vpn-id</i> <b>Example:</b> <pre>Router(config-vrf)# vpn id 1234:123456</pre>	<p>Configures the VPN ID.</p> <ul style="list-style-type: none"> <li>This command is only used if the client (ODAP manager) is also configured with or assigned a VPN ID.</li> </ul>
<b>Step 7</b>	<b>exit</b> <b>Example:</b> <pre>Router(config-vrf)# exit</pre>	<p>Exits VRF configuration mode and enters global configuration mode.</p>
<b>Step 8</b>	<b>ip dhcp pool</b> <i>pool-name</i> <b>Example:</b> <pre>Router(config)# ip dhcp pool VPN-POOL</pre>	<p>Enters DHCP pool configuration mode and specifies the subnet pool name.</p> <ul style="list-style-type: none"> <li>The <b>VRF</b> keyword and <i>vrf-name</i> argument are used to specify the VPN for the VRF pool. The <i>vrf-name</i> argument must match the VRF name (or tag) that is configured for the client.</li> </ul>
<b>Step 9</b>	<b>vrf</b> <i>vrf-name</i> <b>Example:</b> <pre>Router(dhcp-config)#vrf RED</pre>	<p>Associates the on-demand address pool with a VRF instance name.</p> <ul style="list-style-type: none"> <li>The <i>vrf-name</i> argument must match the <i>vrf-name</i> argument that was configured in Step 3.</li> </ul>
<b>Step 10</b>	<b>network</b> <i>network-number</i> [ <i>mask</i> / <i>prefix-length</i> ] <b>Example:</b> <pre>Router(dhcp-config)# network 192.168.0.0 /24</pre>	<p>Configures the subnet number and mask for a DHCP address pool on a Cisco IOS XE DHCP server.</p> <ul style="list-style-type: none"> <li>The subnet mask or the prefix length can be configured in this step. The values that can be</li> </ul>

	Command or Action	Purpose
		configured for the <i>prefix-length</i> argument follow CIDR bit count notation. The forward slash character must be used when configuring the <i>prefix-length</i> argument.
<b>Step 11</b>	<b>subnet prefix-length</b> <i>prefix-length</i> <b>Example:</b> <pre>Router(dhcp-config)# subnet prefix-length 16</pre>	Configures the subnet prefix length. <ul style="list-style-type: none"> <li>• The range of the <i>prefix-length</i> argument is from 1 to 31.</li> <li>• This command configures the number of IP addresses that each subnet is configured to allocate from the subnet pool. The values that can be configured for the <i>prefix-length</i> argument follow CIDR bit count notation format.</li> </ul>

## Verifying the Subnet Allocation and DHCP Bindings

Perform this task to verify subnet allocation and DHCP bindings.

The **show ip dhcp pool** and **show ip dhcp binding** commands do not need to be issued together or even in the same session as there are differences in the information that is provided. These commands, however, can be used to display and verify subnet allocation and DHCP bindings. The **show running-config | begin dhcp** command is used to display the local configuration of DHCP and the configuration of the **subnet prefix-length** command.

### SUMMARY STEPS

1. **enable**
2. **show running-config | begin dhcp**
3. **show ip dhcp pool [pool-name]**
4. **show ip dhcp binding [ip-address]**

### DETAILED STEPS

	Command or Action	Purpose
<b>Step 1</b>	<b>enable</b> <b>Example:</b> <pre>Router&gt; enable</pre>	Enables privileged EXEC mode. <ul style="list-style-type: none"> <li>• Enter your password if prompted.</li> </ul>
<b>Step 2</b>	<b>show running-config   begin dhcp</b> <b>Example:</b> <pre>Router# show running-config   begin dhcp</pre>	Used to display the local configuration of the router. <ul style="list-style-type: none"> <li>• The configuration of the <b>subnet prefix-length</b> command will be displayed under the DHCP pools, for which subnet lease allocation has been configured. The subnet allocation size will be shown, following this command, in CIDR bit count notation.</li> </ul>

	Command or Action	Purpose
		<ul style="list-style-type: none"> <li>The sample output is filtered with the <b>begin</b> keyword to start displaying output at the DHCP section of the running configuration.</li> </ul>
<b>Step 3</b>	<b>show ip dhcp pool [pool-name]</b> <b>Example:</b> <pre>Router# show ip dhcp pool</pre>	Displays information about DHCP pools. <ul style="list-style-type: none"> <li>This command can be used to verify subnet allocation pool configuration on both the subnet allocation server and the ODAP manager.</li> <li>The output of this command displays specific address pool information, including the name of the pool, utilization of address space, subnet size, number of total addresses, number of leased address, and pending events.</li> </ul>
<b>Step 4</b>	<b>show ip dhcp binding [ip-address]</b> <b>Example:</b> <pre>Router# show ip dhcp binding</pre>	Displays information about DHCP bindings. <ul style="list-style-type: none"> <li>This command can be used to display subnet allocation to DHCP binding mapping information.</li> <li>The output from this command displays binding information for individual IP address assignment and allocated subnets. The output that is generated for DHCP IP address assignment and subnet allocation is almost identical, except that subnet leases display an IP address followed by the subnet mask (which shows the size of the allocated subnet). Bindings for individual IP address only display an IP address and are not followed by a subnet mask.</li> </ul>

## Troubleshooting the DHCP ODAP Subnet Allocation Server

Perform this task to troubleshoot the DHCP ODAP subnet allocation server.

### SUMMARY STEPS

1. **enable**
2. **debug dhcp [detail]**
3. **debug ip dhcp server {events | packets | linkage}**

### DETAILED STEPS

	Command or Action	Purpose
<b>Step 1</b>	<b>enable</b> <b>Example:</b> <pre>Router&gt; enable</pre>	Enables privileged EXEC mode. <ul style="list-style-type: none"> <li>Enter your password if prompted.</li> </ul>

	Command or Action	Purpose
Step 2	<b>debug dhcp [detail]</b> <b>Example:</b> <pre>Router# debug dhcp detail</pre>	Displays debugging information about DHCP client activities and monitors the status of DHCP packets. <ul style="list-style-type: none"> <li>This example is issued with the <b>detail</b> keyword on the ODAP manager. The <b>detail</b> keyword is used to display and monitor the lease entry structure of the client and the state transitions of lease entries. This command also displays the values of the op, htype, hlen, hops, server identifier option, xid, secs, flags, ciaddr, yiaddr, siaddr, and giaddr fields of the DHCP packet that are shown in addition to the length of the options field.</li> </ul>
Step 3	<b>debug ip dhcp server {events   packets   linkage}</b> <b>Example:</b> <pre>Router# debug ip dhcp server packets</pre> <b>Example:</b> <pre>Router# debug ip dhcp server events</pre>	Enables DHCP server debugging. <ul style="list-style-type: none"> <li>This example is issued with the <b>packets</b> and <b>events</b> keywords on the subnet allocation server. The output displays lease transition and reception, as well as database information.</li> </ul>

## Configuration Examples for DHCP Server On-Demand Address Pool Manager

### Defining DHCP ODAPs as the Global Default Mechanism Example

The following example shows how to configure the on-demand address pooling mechanism to be used to serve an address request from a PPP client.

```
ip address-pool dhcp-pool
!
ip dhcp pool Green-pool
```

### Defining DHCP ODAPs on an Interface Example

The following example shows how to configure an interface to retrieve an IP address from an on-demand address pool:

```
interface Virtual-Templat1
 ip vrf forwarding green
 ip unnumbered loopback1
 ppp authentication chap
 peer default ip address dhcp-pool
!
```

## Configuring the DHCP Pool as an ODAP Example

The following example shows two ODAPs configured to obtain their subnets from an external DHCP server:

```
Router# show run
Building configuration...
Current configuration : 3943 bytes
!
version 12.2
service timestamps debug uptime
service timestamps log uptime
no service password-encryption
!
hostname Router
!
no logging console
enable password lab
!
username vpn_green_net1 password 0 lab
username vpn_red_net1 password 0 lab
ip subnet-zero
!
ip dhcp pool green_pool
  vrf Green
  utilization mark high 60
  utilization mark low 40
  origin dhcp subnet size initial /24 autogrow /24
!
ip dhcp pool red_pool
  vrf Red
  origin dhcp
!
ip vrf Green
  rd 200:1
  route-target export 200:1
  route-target import 200:1
!
ip vrf Red
  rd 300:1
  route-target export 300:1
  route-target import 300:1
ip cef
ip address-pool dhcp-pool
!
no voice hpi capture buffer
no voice hpi capture destination
!
interface Loopback0
  ip address 1.1.1.1 255.255.255.255
!
interface Loopback1
  ip vrf forwarding Green
  ip address 100.10.10.1 255.255.255.255
!
interface Loopback2
  ip vrf forwarding Red
  ip address 110.10.10.1 255.255.255.255
!
interface ATM2/0/0
  no ip address
  shutdown
  no atm ilmi-keepalive
!
```



```
interface ATM3/0/0
  no ip address
  no atm ilmi-keepalive
!
interface GigabitEthernet0/0/0
  ip address 10.0.105.12 255.255.255.224
  duplex half
!
interface GigabitEthernet0/0/1
  ip address 150.10.10.1 255.255.255.0
  duplex half
!
interface GigabitEthernet0/0/2
  ip address 120.10.10.1 255.255.255.0
  duplex half
  tag-switching ip
!
interface Virtual-Template1
  ip vrf forwarding Green
  ip unnumbered Loopback1
  ppp authentication chap
!
interface Virtual-Template2
  ip vrf forwarding Green
  ip unnumbered Loopback1
  ppp authentication chap
!
interface Virtual-Template3
  ip vrf forwarding Green
  ip unnumbered Loopback1
  ppp authentication chap
!
interface Virtual-Template4
  ip vrf forwarding Red
  ip unnumbered Loopback2
  ppp authentication chap
!
interface Virtual-Template5
  ip vrf forwarding Red
  ip unnumbered Loopback2
  ppp authentication chap
!
interface Virtual-Template6
  ip vrf forwarding Red
  ip unnumbered Loopback2
  ppp authentication chap
!
router ospf 100
  log-adjacency-changes
  redistribute connected
  network 1.1.1.1 0.0.0.0 area 0
  network 120.10.10.0 0.0.0.255 area 0
  network 150.10.10.0 0.0.0.255 area 0
!
router bgp 100
  no synchronization
  bgp log-neighbor-changes
  neighbor 3.3.3.3 remote-as 100
  neighbor 3.3.3.3 update-source Loopback0
!
  address-family ipv4 vrf Red
  redistribute connected
  redistribute static
  no auto-summary
```

```

no synchronization
network 110.0.0.0
exit-address-family
!
address-family ipv4 vrf Green
redistribute connected
redistribute static
no auto-summary
no synchronization
network 100.0.0.0
exit-address-family
!
address-family vpnv4
neighbor 3.3.3.3 activate
neighbor 3.3.3.3 send-community extended
exit-address-family
!
ip classless
ip route 172.19.0.0 255.255.0.0 10.0.105.1
no ip http server
ip pim bidir-enable
!
call rsvp-sync
!
mgcp profile default
!
dial-peer cor custom
!
gatekeeper
shutdown
!
line con 0
exec-timeout 0 0
line aux 0
line vty 0 4
password lab
login
!
end

```

## Configuring the DHCP Pool as an ODAP for Non-MPLS VPNs Example

The following example shows how to configure an interface to retrieve an IP address from an on-demand address pool. In this example, two non-VRF ODAPs are configured. There are two virtual-templates and two DHCP address pools, `usergroup1` and `usergroup2`. Each virtual-template interface is configured to obtain IP addresses for the peer from the associated address pool.

```

!
ip dhcp pool usergroup1
origin dhcp subnet size initial /24 autogrow /24
lease 0 1
!
ip dhcp pool usergroup2
origin dhcp subnet size initial /24 autogrow /24
lease 0 1
!
interface virtual-template1
ip unnumbered loopback1
peer default ip address dhcp-pool usergroup1
!
interface virtual-template2

```

```
ip unnumbered loopback1
peer default ip address dhcp-pool usergroup2
```

## Configuring AAA and RADIUS Example

The following example shows one pool “Green” configured to obtain its subnets from the AAA (RADIUS) server located at IP address 172.16.1.1:

```
!
aaa new-model
!
aaa authorization configuration default group radius
aaa accounting network default start-stop group radius
aaa session-id common
!
ip subnet-zero
!
ip dhcp ping packets 0
!
ip dhcp pool Green
  vrf Green
  utilization mark high 50
  utilization mark low 30
  origin aaa subnet size initial /28 autogrow /28
!
ip vrf Green
  rd 300:1
  route-target export 300:1
  route-target import 300:1
!
interface GigabitEthernet0/1/1
  ip address 172.16.1.12 255.255.255.0
  duplex half
!
interface Virtual-Template1
  ip vrf forwarding Green
  no ip address
!
ip radius source-interface GigabitEthernet0/1/1
!
!IP address of the RADIUS server host
radius-server host 172.16.1.1 auth-port 1645 acct-port 1646
radius-server retransmit 3
radius-server attribute 32 include-in-access-req
radius-server attribute 44 include-in-access-req
radius-server key cisco
radius-server vsa send accounting
radius-server vsa send authentication
```

## Configuring a Global Pool for a Subnet Allocation Server Example

The following example shows how to configure a router to be a subnet allocation server and create a global subnet allocation pool named “GLOBAL-POOL” that allocates subnets from the 10.0.0.0/24 network. The configuration of the **subnet prefix-length** command in this example configures the size of each subnet that is allocated from the subnet pool to support 254 host IP addresses.

```
ip dhcp pool GLOBAL-POOL
  network 10.0.0.0 255.255.255.0
```

```

subnet prefix-length 24
!

```

## Configuring a VRF Pool for a Subnet Allocation Server Example

The following example shows how to configure a router to be a subnet allocation server and create a VRF subnet allocation pool named “VRF-POOL” that allocates subnets from the 172.16.0.0/16 network and configures the VPN to match the VRF named “RED.” The configuration of the **subnet prefix-length** command in this example configures the size of each subnet that is allocated from the subnet pool to support 62 host IP addresses.

```

ip dhcp pool VRF-POOL
vrf RED
network 172.16.0.0 /16
subnet prefix-length 26
!

```

## Using a VPN ID to Configure a VRF Pool on a Subnet Allocation Server Example

The following example shows how to configure a router to be a subnet allocation server and create a VRF subnet allocation pool named “VRF-POOL” that allocates subnets from the 192.168.0.0/24 network and configures the VRF named “RED.” The VPN ID must match the unique identifier that is assigned to the client site. The route target and route distinguisher are configured in the as-number:network-number format. The route target and route distinguisher must match. The configuration of the **subnet prefix-length** command in this example configures the size of each subnet that is allocated from the subnet pool to support 30 host IP addresses.

```

ip vrf RED
rd 100:1
route-target both 100:1
vpn id 1234:123456
exit
ip dhcp pool VPN-POOL
vrf RED
network 192.168.0.0 /24
subnet prefix-length /27
exit

```

## Verifying Local Configuration on a Subnet Allocation Server Example

The following example is output from the **show running-config** command. This command can be used to verify the local configuration on a subnet allocation server. The output from this command displays the configuration of the subnet prefix-length command under the DHCP pool named “GLOBAL-POOL.” The total size of the subnet allocation pool is set to 254 addresses with the **network** command. The configuration of the **subnet prefix-length** command configures this pool to allocate a subnet that will support 254 host IP addresses. Because the total pool size supports only 254 addresses, only one subnet can be allocated from this pool.

```

Router# show running-config | begin dhcp
ip dhcp pool GLOBAL-POOL
  network 10.0.0.0 255.255.255.0
  subnet prefix-length 24
!

```

## Verifying Address Pool Allocation Information Example

The following examples are output from the **show ip dhcp pool** command. This command can be used to verify subnet allocation pool configuration on the subnet allocation server and the ODAP manager. The output from this command displays information about the address pool name, utilization level, configured subnet size, total number of addresses (from subnet), pending events, and specific subnet lease information.

The following sample output shows that the configured subnet allocation size is /24 (254 IP addresses), that there is a pending subnet allocation request, and there are no subnets in the pool:

```
Router> show ip dhcp pool ISP-1
Pool ISP-1 :
  Utilization mark (high/low)      :100 / 0
  Subnet size (first/next)         :24 / 24 (autogrow)
  Total addresses                  :0
  Leased addresses                 :0
  Pending event                    :subnet request
  0 subnet is currently in the pool
```

The next example shows that the configured subnet allocation size is /24 (254 IP address), the configured VRF name is “RED”, and a subnet containing 254 IP addresses has been allocated but no IP addresses have been leased from the subnet:

```
Router> show ip dhcp pool SUBNET-ALLOC
Pool SUBNET-ALLOC :
  Utilization mark (high/low)      :100 / 0
  Subnet size (first/next)         :24 / 24 (autogrow)
  VRF name                        :RED
  Total addresses                  :254
  Leased addresses                 :0
  Pending event                    :none
  1 subnet is currently in the pool :
  Current index      IP address range      Leased addresses
  10.0.0.1           10.0.0.1 - 10.0.0.254          0
```

## Verifying Subnet Allocation and DHCP Bindings Example

The following example is from the **show ip dhcp binding** command. This command can be used to display subnet allocation to DHCP binding mapping information. The output of this command shows the subnet lease to MAC address mapping, the lease expiration, and the lease type (subnet lease bindings are configured to be automatically created and released by default). The output that is generated for DHCP IP address assignment and subnet allocation is almost identical, except that subnet leases display an IP address followed by the subnet mask (which shows the size of the allocated subnet) in CIDR bit count notation. Bindings for individual IP address only display an IP address and are not followed by a subnet mask.

```
Router# show ip dhcp binding
Bindings from all pools not associated with VRF:
IP address      Client-ID/      Lease expiration      Type
                Hardware address/
                User name
10.0.0.0/26    0063.6973.636f.2d64.  Mar 29 2009 04:36 AM  Automatic
                656d.6574.6572.2d47.
                4c4f.4241.4c
```

## Additional References

The following sections provide references related to configuring the DHCP ODAP manager.

### Related Documents

Related Topic	Document Title
DHCP commands: complete command syntax, command modes, command history, defaults, usage guidelines, and examples	<i>Cisco IOS IP Addressing Services Command Reference</i>
DHCP conceptual information	“DHCP Overview” module
DHCP server configuration	“Configuring the Cisco IOS XE DHCP Server” module
DHCP client configuration	“Configuring the Cisco IOS XE DHCP Client” module
DHCP relay agent configuration	“Configuring the Cisco IOS XE DHCP Relay Agent” module
DHCP advanced features	“Configuring DHCP Services for Accounting and Security” module

### Standards

Standards	Title
No new or modified standards are supported by this functionality.	--

### MIBs

MIBs	MIBs Link
No new or modified MIBs are supported by this feature.	To locate and download MIBs for selected platforms, Cisco IOS XE software releases, and feature sets, use Cisco MIB Locator found at the following URL:  <a href="http://www.cisco.com/go/mibs">http://www.cisco.com/go/mibs</a>

### RFCs

RFCs	Title
RFC 951	<i>Bootstrap Protocol (BOOTP)</i>
RFC 1542	<i>Clarifications and Extensions for the Bootstrap Protocol</i>
RFC 2131	<i>Dynamic Host Configuration Protocol</i>
RFC 2685	<i>Virtual Private Networks Identifier</i>

RFCs	Title
RFC 3046	<i>DHCP Relay Information Option</i>

### Technical Assistance

Description	Link
<p>The Cisco Support website provides extensive online resources, including documentation and tools for troubleshooting and resolving technical issues with Cisco products and technologies.</p> <p>To receive security and technical information about your products, you can subscribe to various services, such as the Product Alert Tool (accessed from Field Notices), the Cisco Technical Services Newsletter, and Really Simple Syndication (RSS) Feeds.</p> <p>Access to most tools on the Cisco Support website requires a Cisco.com user ID and password.</p>	<a href="http://www.cisco.com/public/support/tac/home.shtml">http://www.cisco.com/public/support/tac/home.shtml</a>

## Feature Information for the DHCP Server On-Demand Address Pool Manager

The following table provides release information about the feature or features described in this module. This table lists only the software release that introduced support for a given feature in a given software release train. Unless noted otherwise, subsequent releases of that software release train also support that feature.

Use Cisco Feature Navigator to find information about platform support and Cisco software image support. To access Cisco Feature Navigator, go to [www.cisco.com/go/cfn](http://www.cisco.com/go/cfn). An account on Cisco.com is not required.

**Table 5: Feature Information for the DHCP On-Demand Address Pool Manager**

Feature Name	Releases	Feature Configuration Information
DHCP Server On-Demand Address Pool Manager for Non-MPLS VPNs	Cisco IOS XE Release 2.3 Cisco IOS XE Release 3.9S	This feature was enhanced to provide ODAP support for non-MPLS VPNs. The following command was modified by this feature: <b>peer default ip address</b>
DHCP ODAP Server Support	Cisco IOS XE Release 2.3 Cisco IOS XE Release 3.9S	This feature introduces the capability to configure a DHCP server (or router) as a subnet allocation server. This capability allows the Cisco IOS DHCP server to be configured with a pool of subnets for lease to ODAP clients. The following commands were introduced or modified by this feature: <b>subnet prefix-length</b> and <b>show ip dhcp binding</b>

Feature Name	Releases	Feature Configuration Information
DHCP Server On-Demand Address Pool Manager	Cisco IOS XE Release 2.3	<p>The ODAP manager is used to centralize the management of large pools of addresses and simplify the configuration of large networks. ODAP provides a central management point for the allocation and assignment of IP addresses. When a Cisco IOS router is configured as an ODAP manager, pools of IP addresses are dynamically increased or reduced in size depending on the address utilization level.</p> <p>The following commands were introduced by this feature: <b>aaa session-id, clear ip dhcp subnet, ip address pool, ip dhcp aaa default username, origin, show ip dhcp pool, utilization mark high, utilization mark low, vrf.</b></p> <p>The following commands were modified by this feature: <b>clear ip dhcp binding, clear ip dhcp conflict, ip address-pool, peer default ip address.</b></p>

## Glossary

**AAA** --authentication, authorization, and accounting. Suite of network security services that provide the primary framework through which access control can be set up on your Cisco router or access server.

**Cisco Access Registrar** --A RADIUS server that supports service provider deployment of access services by centralizing AAA information and simplifying provisioning and management.

**client** --A host trying to configure its interface (obtain an IP address) using DHCP or BOOTP protocols.

**DHCP** --Dynamic Host Configuration Protocol.

**incremental subnet size** --The desired size of the second and subsequent subnets requested for an on-demand pool.

**initial subnet size** --The desired size of the first subnet requested for an on-demand pool.

**IPCP** --IP Control Protocol. Protocol that establishes and configures IP over PPP.

**MPLS** --Multiprotocol Label Switching. Emerging industry standard upon which tag switching is based.

**ODAP** --on-demand address pool.

**PE router** --provider edge router.

**PPP** --Point-to-Point Protocol.

**RADIUS** -- Remote Authentication Dial-In User Service. Database for authenticating modem and ISDN connections and for tracking connection time.

**relay agent** --A router that forwards DHCP and BOOTP messages between a server and a client on different subnets.

**releasable subnet** --A leased subnet that has no address leased from it.

**server** --DHCP or BOOTP server.

**VHG** --Virtual Home Gateway. A Cisco IOS software component that terminates PPP sessions. It is owned and managed by the service provider on behalf of its customer to provide access to remote users of that



customers network. A single service provider device (router) can host multiple VHGs of different customers. A VHG can be dynamically brought up and down based on the access pattern of the remote users. Note that there is no single IOS feature called the VHG; it is a collection of function and features.

**VHG/PE router**--A device that terminates PPP sessions and maps the remote users to the corresponding MPLS VPNs.

**VPN** --Virtual Private Network. Enables IP traffic to use tunneling to travel securely over a public TCP/IP network.

**VPN information** --In this document, VPN information refers to VRF name or VPN ID.

**VRF** --VPN routing and forwarding instance. A VRF consists of an IP routing table, a derived forwarding table, a set of interfaces that use the forwarding table, and a set of rules and routing protocols that determine what goes into the forwarding table. In general, a VRF includes the routing information that defines a customer VPN site that is attached to a PE router. Each VPN instantiated on the PE router has its own VRF.





## CHAPTER 4

# Configuring the Cisco IOS XE DHCP Relay Agent

Cisco routers running Cisco IOS XE software include Dynamic Host Configuration Protocol (DHCP) server and relay agent software. A DHCP relay agent is any host that forwards DHCP packets between clients and servers. This module describes the concepts and tasks needed to configure the Cisco IOS XE DHCP relay agent.

- [Finding Feature Information, on page 85](#)
- [Prerequisites for Configuring the DHCP Relay Agent, on page 85](#)
- [Information About the DHCP Relay Agent, on page 86](#)
- [How to Configure the DHCP Relay Agent, on page 91](#)
- [Configuration Examples for the DHCP Relay Agent, on page 102](#)
- [Additional References, on page 104](#)
- [Technical Assistance, on page 106](#)
- [Feature Information for the Cisco IOS XE DHCP Relay Agent, on page 106](#)
- [Glossary, on page 107](#)

## Finding Feature Information

Your software release may not support all the features documented in this module. For the latest caveats and feature information, see [Bug Search Tool](#) and the release notes for your platform and software release. To find information about the features documented in this module, and to see a list of the releases in which each feature is supported, see the feature information table.

Use Cisco Feature Navigator to find information about platform support and Cisco software image support. To access Cisco Feature Navigator, go to [www.cisco.com/go/cfn](http://www.cisco.com/go/cfn). An account on Cisco.com is not required.

## Prerequisites for Configuring the DHCP Relay Agent

Before you configure the DHCP relay agent, you should understand the concepts documented in the “DHCP Overview” module.

The Cisco IOS XE DHCP server and relay agent are enabled by default. You can verify if they have been disabled by checking your configuration file. If they have been disabled, the **no service dhcp** command will appear in the configuration file. Use the **service dhcp** command to reenabling the functionality if necessary.

The Cisco IOS XE DHCP relay agent will be enabled on an interface only when the **ip helper-address** is configured. This command enables the DHCP broadcast to be forwarded to the configured DHCP server.

# Information About the DHCP Relay Agent

## DHCP Relay Agent Overview

A DHCP relay agent is any host that forwards DHCP packets between clients and servers. Relay agents are used to forward requests and replies between clients and servers when they are not on the same physical subnet. Relay agent forwarding is distinct from the normal forwarding of an IP device, where IP datagrams are switched between networks somewhat transparently. By contrast, relay agents receive DHCP messages and then generate a new DHCP message to send out on another interface. The relay agent sets the gateway IP address (giaddr field of the DHCP packet) and, if configured, adds the relay agent information option (option82) in the packet and forwards it to the DHCP server. The reply from the server is forwarded back to the client after removing option 82.

The DHCP relay agent supports the use of unnumbered interfaces. An unnumbered interface can “borrow” the IP address of another interface already configured on the device, which conserves network and address space. For DHCP clients connected through the unnumbered interfaces, the DHCP relay agent automatically adds a static host route once the DHCP client obtains an address, specifying the unnumbered interface as the outbound interface. The route is automatically removed once the lease time expires or when the client releases the address.

## Packet Forwarding Address

DHCP clients need to use User Datagram Protocol (UDP) broadcasts to send their initial DHCPDISCOVER messages because they don't have information about the network to which they are attached. If the client is on a network segment that does not include a server, UDP broadcasts normally are not forwarded because most routers are configured to not forward broadcast traffic.

You can remedy this situation by configuring the interface of your router that is receiving the broadcasts to forward certain classes of broadcasts to a helper address. You can use more than one helper address per interface.

When a router forwards these address assignment/parameter requests, it is acting as a DHCP relay agent. The Cisco router implementation of the DHCP relay agent is provided via the **ip helper-address** interface configuration command.

In the figure below, the DHCP client broadcasts a request for an IP address and additional configuration parameters on its local LAN. Router B, acting as a DHCP relay agent, picks up the broadcast and generates a new DHCP message to send out on another interface. As part of this DHCP message, the relay agent inserts the IP address of the interface containing the **ip helper-address** command into the gateway IP address (giaddr) field of the DHCP packet. This IP address enables the DHCP server to determine which subnet should receive the offer and identify the appropriate IP address range to offer. The DHCP relay agent sends the local broadcast, via IP unicast, to the DHCP server address 172.16.1.2 specified by the **ip helper-address** interface configuration command.

Figure 4: Forwarding UDP Broadcasts to a DHCP Server Using a Helper Address

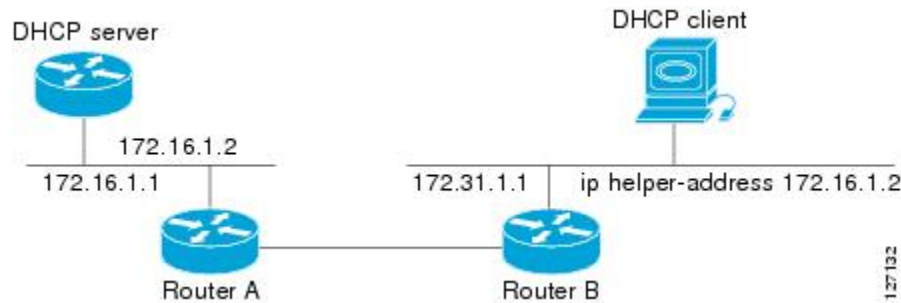

## Relay Agent Information Option

Automatic DHCP address allocation is typically based on an IP address, whether it be the gateway IP address (giaddr field of the DHCP packet) or the incoming interface IP address. In some networks, it is necessary to use additional information to further determine which IP addresses to allocate. By using the relay agent information option (option 82), the Cisco IOS XE relay agent can include additional information about itself when forwarding client-originated DHCP packets to a DHCP server.

Cisco IOS XE supports this functionality by using the **ip dhcp relay information option** command. The relay agent will automatically add the circuit identifier suboption and the remote ID suboption to the relay agent information option and forward them to the DHCP server.

The DHCP server can use this information to assign IP addresses, perform access control, and set quality of service (QoS) and security policies (or other parameter-assignment policies) for each subscriber of a service provider network.



### Note

When CTS role-based enforcement is enabled, broadcast packets are dropped if the default policy is deny all. To allow the DHCP snooping broadcast packets, the default policy must have an ACE to permit the DHCP broadcast traffic.

The figure below shows how the relay agent information option is inserted into the DHCP packet as follows:

1. The DHCP client generates a DHCP request and broadcasts it on the network.
2. The DHCP relay agent intercepts the broadcast DHCP request packet and inserts the relay agent information option (option 82) in the packet. The relay agent information option contains the related suboptions.
3. The DHCP relay agent unicasts the DHCP packet to the DHCP server.
4. The DHCP server receives the packet and uses the suboptions to assign IP addresses and other configuration parameters and forwards them back to the client.
5. The relay agent strips off the suboption fields of the packet while forwarding to the client.

Figure 5: Relay Agent Information Option Operation

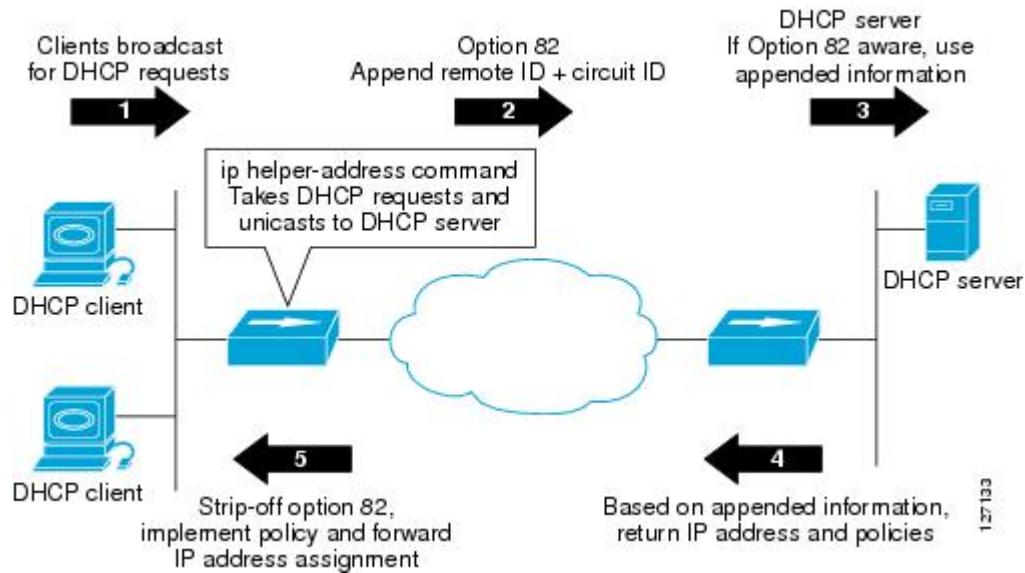

## Relay Agent Information Reforwarding Policy

A DHCP relay agent may receive a message from another DHCP relay agent that already contains relay information. By default, the relay information from the previous relay agent is replaced. If this behavior is not suitable for your network, you can use the **ip dhcp relay information policy {drop | keep | replace}** global configuration command to change it.

To ensure the correct operation of the reforwarding policy, make sure to disable the relay agent information check by using the **no ip dhcp relay information check** global configuration command.

## DHCP Relay Agent Support for MPLS VPNs

DHCP relay support for Multiprotocol Label Switching (MPLS) Virtual Private Networks (VPNs) enables a network administrator to conserve address space by allowing overlapping addresses. The relay agent can support multiple clients on different VPNs, and many of these clients from different VPNs can share the same IP address.

Configuring VPNs involves an adjustment to the usual DHCP host IP address designation. VPNs use private address spaces that might not be unique across the Internet.

In some environments, a relay agent resides in a network element that also has access to one or more MPLS VPNs. A DHCP server that provides service to DHCP clients on those different VPNs must locate the VPN in which each client resides. The network element that contains the relay agent typically captures the VPN association of the DHCP client and includes this information in the relay agent information option of the DHCP packet.

DHCP relay support for MPLS VPNs allows the relay agent to forward this necessary VPN-related information to the DHCP server using the following three suboptions of the DHCP relay agent information option:

- VPN identifier
- Subnet selection

- Server identifier override

The VPN identifier suboption is used by the relay agent to tell the DHCP server the VPN for every DHCP request it passes on to the DHCP server, and it is also used to properly forward any DHCP reply that the DHCP server sends back to the relay agent. The VPN identifier suboption contains the VPN ID configured on the incoming interface to which the client is connected. If you configure the VRF name but not the VPN ID, the VRF name is used as the VPN identifier suboption. If the interface is in global routing space, the VPN suboptions are not added.

The subnet selection suboption allows the separation of the subnet where the client resides from the IP address used to communicate with the relay agent. In typical DHCP processing, the gateway address specifies both the subnet on which a DHCP client resides and the IP address that the server can use to communicate with the relay agent. Situations exist where the relay agent needs to specify the subnet on which a DHCP client resides that is different from the IP address the server can use to communicate with the relay agent. The subnet selection suboption is included in the relay agent information option and passed on to the DHCP server. The gateway address is changed to the outgoing interface of the relay agent toward the DHCP server. The DHCP server uses this gateway address to send reply packets back to the relay agent.

The server identifier override suboption value is copied in the reply packet from the DHCP server instead of the normal server ID address. The server identifier override suboption contains the incoming interface IP address, which is the IP address on the relay agent that is accessible from the client. Using this information, the DHCP client sends all renew and release packets to the relay agent. The relay agent adds all of the VPN suboptions and then forwards the renew and release packets to the original DHCP server.

After adding these suboptions to the DHCP relay agent information option, the gateway address is changed to the outgoing interface of the relay agent toward the DHCP server. When the packets are returned from the DHCP server, the relay agent removes the relay agent information options and forwards the packets to the DHCP client on the correct VPN.

The figure below shows a VPN scenario where the DHCP relay agent and DHCP server can recognize the VPN that each client resides within. DHCP client 1 is part of VPN green and DHCP client 2 is part of VPN red and both have the same private IP address 192.168.1.0/24. Because the clients have the same IP address, the DHCP relay agent and DHCP server use the VPN identifier, subnet selection, and server identifier override suboptions of the relay agent information option to distinguish the correct VPN of the client.

Figure 6: Virtual Private Network DHCP Configuration

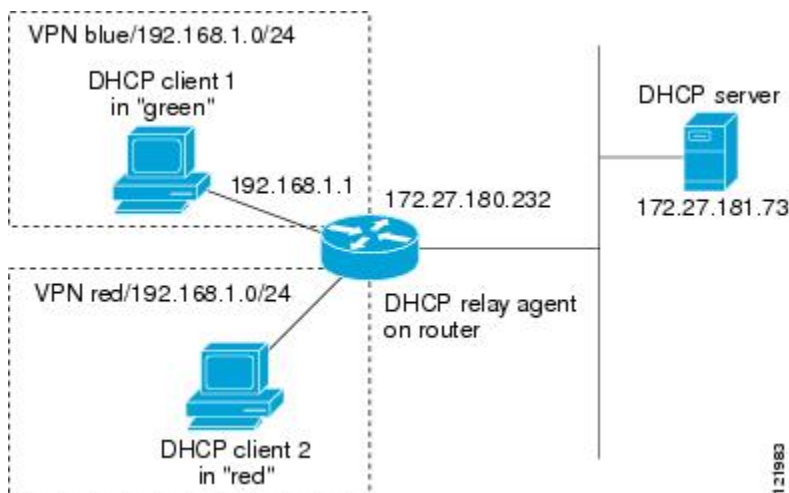

## DHCP Relay Support for Option 82 Encapsulation

When two relay agents are relaying messages between the DHCP client and DHCP server, the second relay agent (closer to the server), by default, replaces the first option 82 information with its own option 82. The remote ID and circuit ID information from the first relay agent is lost. In some deployment scenarios, it is necessary to maintain the initial option 82 from the first relay agent, in addition to the option 82 from the second relay agent. For example, an Intelligent Service Gateway (ISG) acting as a second relay agent is connected to a Layer 2 device. The Layer 2 device connects to the household and identifies the household with its own option 82.

The DHCP Relay Option 82 Encapsulation feature allows the second relay agent to encapsulate option 82 information in a received message from the first relay agent if it is also configured to add its own option 82 information. This configuration allows the DHCP server to use option 82 information from both relay agents. The DHCP server can use the VPN information from the second relay agent along with the option 82 information from the first relay agent to send correct address assignments and other configuration parameters for the client devices based on the VRF, option 60, and encapsulated option 82. The reply message from the DHCP server to the DHCP client traverses the same path as the request messages through the two relay agents to the DHCP client.

Figure 4 shows the processing that occurs on the two relay agents and the DHCP server when this feature is configured:

1. The DHCP client generates a DHCP message (including option 60) and broadcasts it on the network.
2. The first DHCP relay agent intercepts the broadcast DHCP request packet and inserts its own option 82 in the packet.
3. The relay agent automatically adds the circuit ID suboption and the remote ID suboption to option 82 and forwards them to the second relay agent.
4. The second relay agent encapsulates the first relay agent's option 82 and inserts its own option 82.
5. The gateway IP address (giaddr) is set to the incoming interface on the second relay agent and the original giaddr from the first relay agent is encapsulated.
6. The second DHCP relay agent unicasts the DHCP packet to the DHCP server.
7. The DHCP server receives the packet and uses the VPN suboption information from the second relay, along with the option 82 information from the first relay agent, to assign IP addresses and other configuration parameters and forwards the packet back to the second relay agent.
8. When the second relay agent receives the reply message from the server, it restores the encapsulated option 82 and prior giaddr from the first relay agent. The reply message is then sent to the prior giaddr.
9. The option 82 is stripped off of the packet by the first relay agent before forwarding to the client.



Figure 7: DHCP Relay Agent Information Option Encapsulation Support Processing

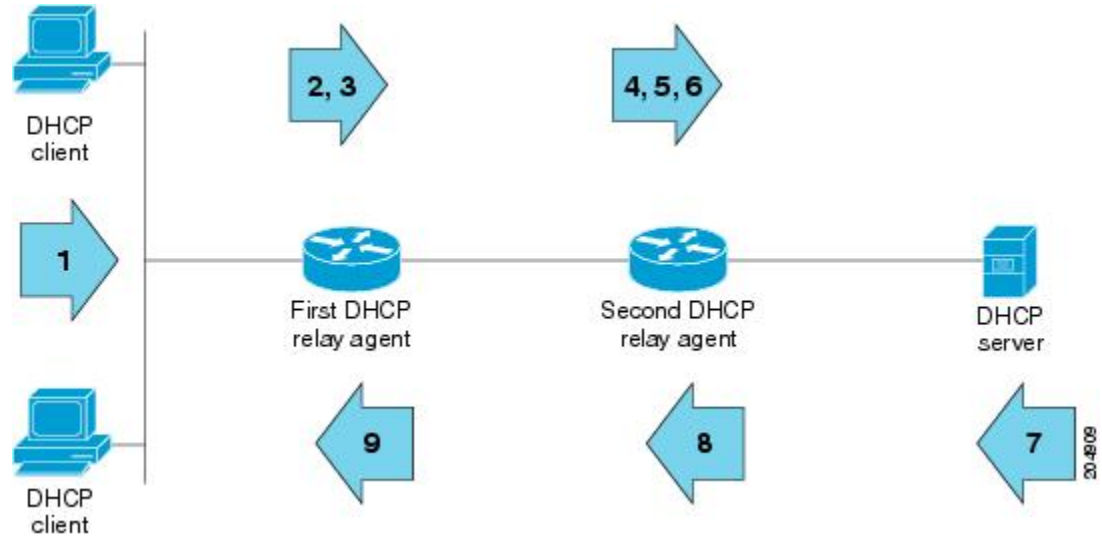

# How to Configure the DHCP Relay Agent

## Specifying the Packet Forwarding Address

Perform this task to configure the DHCP relay agent to forward packets to a DHCP server.

### SUMMARY STEPS

1. `enable`
2. `configure terminal`
3. `interface type number`
4. `ip helper-address address`

### DETAILED STEPS

	Command or Action	Purpose
Step 1	<code>enable</code> <b>Example:</b> Device> enable	Enables privileged EXEC mode. <ul style="list-style-type: none"> <li>• Enter your password if prompted.</li> </ul>
Step 2	<code>configure terminal</code> <b>Example:</b> Device# configure terminal	Enters global configuration mode.

	Command or Action	Purpose
<b>Step 3</b>	<b>interface</b> <i>type number</i> <b>Example:</b> <pre>Device(config)# interface GigabitEthernet0/0/0</pre>	Configures an interface and enters interface configuration mode.
<b>Step 4</b>	<b>ip helper-address</b> <i>address</i> <b>Example:</b> <pre>Device(config-if)# ip helper-address 172.16.1.2</pre>	Forwards UPD broadcasts, including BOOTP and DHCP. <ul style="list-style-type: none"> <li>• The <i>address</i> argument can be a specific DHCP server address, or it can be the network address if other DHCP servers are on the destination network segment. Using the network address enables other servers to respond to DHCP requests.</li> <li>• If you have multiple servers, you can configure one helper address for each server.</li> </ul> <p><b>Note</b> If Intelligent Wireless Access Gateway (IWAG) router is relaying DHCP packets to external DHCP server, it requires to configure DHCP relay pool instead of <b>ip helper address</b> under subscriber interface to be stateful.</p> <pre><b>ip dhcp pool</b> <i>DHCP_Relay_pool_name</i></pre> <pre>ip dhcp pool relay_pool1 relay source 10.56.151.76 relay destination 10.48.155.76</pre>

## Configuring Relay Agent Information Option Support

Perform this task to enable support for the DHCP relay agent information option.



### Note

- If an **ip dhcp relay information** command is configured in global configuration mode but not configured in interface configuration mode, the global configuration is applied to all interfaces.
- If an **ip dhcp relay information** command is configured in both global configuration mode and interface configuration mode, the interface configuration command takes precedence over the global configuration command. However, the global configuration is applied to interfaces without the interface configuration.
- If an **ip dhcp relay information** command is not configured in global configuration mode but is configured in interface configuration mode, only the interface with the configuration option applied is affected. All other interfaces are not impacted by the configuration.

See the "Configuring Relay Agent Information Option Support per Interface" section for more information on per-interface support for the relay agent information option. >

### SUMMARY STEPS

1. enable

2. **configure terminal**
3. **ip dhcp relay information option**
4. **ip dhcp relay information check**
5. **ip dhcp relay information policy {drop | keep | replace}**
6. **ip dhcp relay information trust-all**
7. **end**
8. **show ip dhcp relay information trusted-sources**

## DETAILED STEPS

	Command or Action	Purpose
Step 1	<b>enable</b> <b>Example:</b> <pre>Router&gt; enable</pre>	Enables privileged EXEC mode. <ul style="list-style-type: none"> <li>• Enter your password if prompted.</li> </ul>
Step 2	<b>configure terminal</b> <b>Example:</b> <pre>Router# configure terminal</pre>	Enters global configuration mode.
Step 3	<b>ip dhcp relay information option</b> <b>Example:</b> <pre>Router(config)# ip dhcp relay information option</pre>	Enables the system to insert the DHCP relay agent information option (option-82 field) in forwarded BOOTREQUEST messages to a DHCP server. <ul style="list-style-type: none"> <li>• This function is disabled by default.</li> </ul>
Step 4	<b>ip dhcp relay information check</b> <b>Example:</b> <pre>Router(config)# ip dhcp relay information check</pre>	(Optional) Configures DHCP to check that the relay agent information option in forwarded BOOTREPLY messages is valid. <ul style="list-style-type: none"> <li>• By default, DHCP checks that the option-82 field in DHCP reply packets it receives from the DHCP server is valid. If an invalid message is received, the relay agent drops it. If a valid message is received, the relay agent removes the option-82 field and forwards the packet. Use the <b>ip dhcp relay information check</b> command to reenabling this functionality if it has been disabled.</li> </ul>
Step 5	<b>ip dhcp relay information policy {drop   keep   replace}</b> <b>Example:</b> <pre>Router(config)# ip dhcp relay information policy replace</pre>	(Optional) Configures the reforwarding policy for a DHCP relay agent (what a relay agent should do if a message already contains relay information). <ul style="list-style-type: none"> <li>• See the "Relay Agent Information Reforwarding Policy" section for more information.</li> </ul>
Step 6	<b>ip dhcp relay information trust-all</b> <b>Example:</b>	(Optional) Configures all interfaces on a router as trusted sources of the DHCP relay information option.

	Command or Action	Purpose
	<pre>Router(config)# ip dhcp relay information trust-all</pre>	<ul style="list-style-type: none"> <li>• By default, if the gateway address is set to all zeros in the DHCP packet and the relay agent information option is already present in the packet, the DHCP relay agent will discard the packet. Use the <b>ip dhcp relay information trust-all</b> command to override this behavior and accept the packets.</li> <li>• This command is useful if there is a switch in between the client and the relay agent that may insert option 82. Use this command to ensure that these packets do not get dropped.</li> <li>• You can configure an individual interface as a trusted source of the DHCP relay information option by using the <b>ip dhcp relay information trusted</b> interface configuration mode command.</li> </ul>
<b>Step 7</b>	<p><b>end</b></p> <p><b>Example:</b></p> <pre>Router(config)# end</pre>	Returns to privileged EXEC mode.
<b>Step 8</b>	<p><b>show ip dhcp relay information trusted-sources</b></p> <p><b>Example:</b></p> <pre>Router# show ip dhcp relay information trusted-sources</pre>	(Optional) Displays all interfaces configured to be a trusted source for the DHCP relay information option.

## Configuring Relay Agent Information Option Support per Interface

Perform this task to enable support for the DHCP relay agent information option (option 82) on a per interface basis.

The interface configuration allows the subscribers with different DHCP option 82 requirements on different interfaces to be reached from one Cisco router.

### Before you begin

Read the “Restrictions” and “Relay Agent Information Reforwarding Policy” sections to understand how DHCP processes the relay agent information option for global configurations.

**Note**

- If an **ip dhcp relay information** command is configured in global configuration mode but not configured in interface configuration mode, the global configuration is applied to all interfaces.
- If an **ip dhcp relay information** command is configured in both global configuration mode and interface configuration mode, the interface configuration command takes precedence over the global configuration command. However, the global configuration is applied to interfaces without the interface configuration.
- If an **ip dhcp relay information** command is not configured in global configuration mode but is configured in interface configuration mode, only the interface with the configuration option applied is affected. All other interfaces are not impacted by the configuration.

&gt;

**SUMMARY STEPS**

1. **enable**
2. **configure terminal**
3. **interface** *type number*
4. **ip dhcp relay information option-insert** [none]
5. **ip dhcp relay information check-reply** [none]
6. **ip dhcp relay information policy-action** {drop| keep| replace}
7. **exit**
8. Repeat Steps 3 through 7 to configure relay agent information settings on different interfaces.

**DETAILED STEPS**

	Command or Action	Purpose
<b>Step 1</b>	<b>enable</b> <b>Example:</b> Router> enable	Enables privileged EXEC mode. <ul style="list-style-type: none"> <li>• Enter your password if prompted.</li> </ul>
<b>Step 2</b>	<b>configure terminal</b> <b>Example:</b> Router# configure terminal	Enters global configuration mode.
<b>Step 3</b>	<b>interface</b> <i>type number</i> <b>Example:</b> Router(config)# interface GigabitEthernet0/0/0	Configures an interface and enters interface configuration mode.
<b>Step 4</b>	<b>ip dhcp relay information option-insert</b> [none] <b>Example:</b> Router(config-if)# ip dhcp relay information option-insert	Enables the system to insert the DHCP relay agent information option (option-82 field) in forwarded BOOTREQUEST messages to a DHCP server. <ul style="list-style-type: none"> <li>• This function is disabled by default. However, if support for the relay agent information option is configured in global configuration mode, but not in</li> </ul>

	Command or Action	Purpose
		<p>interface configuration mode, the interface inherits the global configuration.</p> <ul style="list-style-type: none"> <li>The <b>ip dhcp relay information option-insert none</b> interface configuration command is saved in the running configuration. This command takes precedence over any global relay agent information configuration.</li> </ul>
<b>Step 5</b>	<p><b>ip dhcp relay information check-reply [none]</b></p> <p><b>Example:</b></p> <pre>Router(config-if)# ip dhcp relay information check-reply</pre>	<p>Configures a DHCP server to validate the relay information option in forwarded BOOTREPLY messages.</p> <ul style="list-style-type: none"> <li>By default, DHCP checks that the option-82 field in DHCP reply packets it receives from the DHCP server is valid. If an invalid message is received, the relay agent drops it. If a valid message is received, the relay agent removes the option-82 field and forwards the packet. Use the <b>ip dhcp relay information check-reply</b> command to reenble this functionality if it has been disabled.</li> <li>The <b>ip dhcp relay information check-reply none</b> interface configuration command option is saved in the running configuration. This command takes precedence over any global relay agent information configuration.</li> </ul>
<b>Step 6</b>	<p><b>ip dhcp relay information policy-action {drop  keep  replace}</b></p> <p><b>Example:</b></p> <pre>Router(config-if)# ip dhcp relay information policy-action replace</pre>	<p>Configures the information reforwarding policy for a DHCP relay agent (what a relay agent should do if a message already contains relay information).</p>
<b>Step 7</b>	<p><b>exit</b></p> <p><b>Example:</b></p> <pre>Router(config-if)# exit</pre>	<p>Exits interface configuration mode.</p>
<b>Step 8</b>	<p>Repeat Steps 3 through 7 to configure relay agent information settings on different interfaces.</p>	<p>(Optional)</p>

## Configuring the Subscriber Identifier Suboption of the Relay Agent Information Option

Perform this task to enable an Internet service provider (ISP) to add a unique identifier to the subscriber-identifier suboption of the relay agent information option.

The unique identifier enables an ISP to identify a subscriber, to assign specific actions to that subscriber (for example, assignment of host IP address, subnet mask, and domain name system DNS), and to trigger accounting.

Before the introduction of this feature, if a subscriber moved, each ISP had to be informed of the change and all ISPs had to reconfigure the DHCP settings for the affected customers at the same time. Even if the service was not changed, every move involved administrative changes in the ISP environment. With the introduction of this feature, if a subscriber moves from one Network Access Server to another, there is no need for a change in the configuration on the part of the DHCP server or ISP.

### Before you begin

You should configure the unique identifier for each subscriber.

The new configurable subscriber-identifier option should be configured on the interface connected to the client. When a subscriber moves from one interface to the other, the interface configuration should also be changed.

The server should be able to recognize the new suboption.

## SUMMARY STEPS

1. **enable**
2. **configure terminal**
3. **ip dhcp relay information option**
4. **interface** *type number*
5. **ip dhcp relay information option subscriber-id** *string*

## DETAILED STEPS

	Command or Action	Purpose
Step 1	<b>enable</b> <b>Example:</b>  Device> enable	Enables privileged EXEC mode.  • Enter your password if prompted.
Step 2	<b>configure terminal</b> <b>Example:</b>  Device# configure terminal	Enters global configuration mode.
Step 3	<b>ip dhcp relay information option</b> <b>Example:</b>  Device(config)# ip dhcp relay information option	Enables the system to insert the DHCP relay agent information option (option-82 field) in forwarded BOOTREQUEST messages to a DHCP server.  • This function is disabled by default.
Step 4	<b>interface</b> <i>type number</i> <b>Example:</b>  Device(config)# interface atm4/0/0	Configures an interface and enters interface configuration mode.
Step 5	<b>ip dhcp relay information option subscriber-id</b> <i>string</i> <b>Example:</b>	Specifies that a DHCP relay agent add a subscriber identifier suboption to the relay information option.

	Command or Action	Purpose
	<pre>Device(config-if)# ip dhcp relay information option subscriber-id newsubscriber123</pre>	<ul style="list-style-type: none"> <li>The <i>string</i> argument can be up to a maximum of 50 characters and can be alphanumeric.</li> </ul> <p><b>Note</b> If more than 50 characters are configured, the string is truncated.</p> <p><b>Note</b> The <b>ip dhcp relay information option subscriber-id</b> command is disabled by default to ensure backward capability.</p>

## Configuring DHCP Relay Agent Support for MPLS VPNs

Perform this task to configure DHCP relay agent support for MPLS VPNs.

### Before you begin

Before configuring DHCP relay support for MPLS VPNs, you must configure standard MPLS VPNs.

### SUMMARY STEPS

- enable
- configure terminal
- ip dhcp relay information option vpn
- interface *type number*
- ip helper-address vrf *name* [**global**] *address*

### DETAILED STEPS

	Command or Action	Purpose
<b>Step 1</b>	<pre>enable</pre> <p><b>Example:</b></p> <pre>Device&gt; enable</pre>	Enables privileged EXEC mode. <ul style="list-style-type: none"> <li>Enter your password if prompted.</li> </ul>
<b>Step 2</b>	<pre>configure terminal</pre> <p><b>Example:</b></p> <pre>Device# configure terminal</pre>	Enters global configuration mode.
<b>Step 3</b>	<pre>ip dhcp relay information option vpn</pre> <p><b>Example:</b></p> <pre>Device(config)# ip dhcp relay information option vpn</pre>	Enables the system to insert VPN suboptions into the DHCP relay agent information option in forwarded BOOTREQUEST messages to a DHCP server and sets the gateway address to the outgoing interface toward the DHCP server. <ul style="list-style-type: none"> <li>The VPN suboptions are also added to the BOOTP broadcast packets when the command is configured.</li> </ul>



	Command or Action	Purpose
Step 4	<b>interface</b> <i>type number</i> <b>Example:</b> <pre>Device(config)# interface GigabitEthernet0/0/0</pre>	Configures an interface and enters interface configuration mode.
Step 5	<b>ip helper-address vrf</b> <i>name</i> [ <b>global</b> ] <i>address</i> <b>Example:</b> <pre>Device(config-if)# ip helper-address vrf blue 172.27.180.232</pre>	Forwards UDP broadcasts, including BOOTP, received on an interface. <ul style="list-style-type: none"> <li>• If the DHCP server resides in a different VPN or global space that is different from the VPN, then the <b>vrf</b> <i>name</i> or <b>global</b> options allow you to specify the name of the VRF or global space in which the DHCP server resides.</li> </ul>

## Setting the Gateway Address of the DHCP Broadcast to a Secondary Address Using Smart Relay Agent Forwarding

You only need to configure helper addresses on the interface where the UDP broadcasts that you want to forward to the DHCP server are being received. You only need to configure the **ip dhcp smart-relay** command if you have secondary addresses on that interface and you want the device to step through each IP network when forwarding DHCP requests. If smart relay agent forwarding is not configured, all requests are forwarded using the primary IP address on the interface.

If the **ip dhcp smart-relay** command is configured, the relay agent counts the number of times that the client retries sending a request to the DHCP server when there is no DHCPOFFER message from the DHCP server. After three retries, the relay agent sets the gateway address to the secondary address. If the DHCP server still does not respond after three more retries, then the next secondary address is used as the gateway address.

This functionality is useful when the DHCP server cannot be configured to use secondary pools.

### SUMMARY STEPS

1. **enable**
2. **configure terminal**
3. **ip dhcp smart-relay**
4. **exit**

### DETAILED STEPS

	Command or Action	Purpose
Step 1	<b>enable</b> <b>Example:</b> <pre>Device&gt; enable</pre>	Enables privileged EXEC mode. <ul style="list-style-type: none"> <li>• Enter your password if prompted.</li> </ul>
Step 2	<b>configure terminal</b> <b>Example:</b>	Enters global configuration mode.

	Command or Action	Purpose
	Device# configure terminal	
<b>Step 3</b>	<b>ip dhcp smart-relay</b> <b>Example:</b> Device(config)# ip dhcp smart-relay	Allows the DHCP relay agent to switch the gateway address (giaddr field of a DHCP packet) to a secondary address when there is no DHCPOFFER message from a DHCP server.
<b>Step 4</b>	<b>exit</b> <b>Example:</b> Device(config)# exit	Returns to privileged EXEC mode.

## Configuring Relay Agent Information Option Encapsulation Support

Perform this task to enable support for the encapsulation of the DHCP relay agent information option (option 82).

### SUMMARY STEPS

1. enable
2. configure terminal
3. ip dhcp relay information option
4. ip dhcp relay information option vpn
5. ip dhcp relay information policy encapsulate
6. interface *type number*
7. ip dhcp relay information policy-action encapsulate

### DETAILED STEPS

	Command or Action	Purpose
<b>Step 1</b>	<b>enable</b> <b>Example:</b> Router> enable	Enables privileged EXEC mode. <ul style="list-style-type: none"> <li>• Enter your password if prompted.</li> </ul>
<b>Step 2</b>	<b>configure terminal</b> <b>Example:</b> Router# configure terminal	Enters global configuration mode.
<b>Step 3</b>	<b>ip dhcp relay information option</b> <b>Example:</b> Router(config)# ip dhcp relay information option	Enables the system to insert the DHCP relay agent information option (option-82 field) in forwarded BOOTREQUEST messages to a DHCP server. <ul style="list-style-type: none"> <li>• This function is disabled by default.</li> </ul>

	Command or Action	Purpose
Step 4	<p><b>ip dhcp relay information option vpn</b></p> <p><b>Example:</b></p> <pre>Router(config)# ip dhcp relay information option vpn</pre>	<p>(Optional) Enables the system to insert VPN suboptions into the DHCP relay agent information option in forwarded BOOTREQUEST messages to a DHCP server and sets the gateway address to the outgoing interface toward the DHCP server.</p> <ul style="list-style-type: none"> <li>The VPN suboptions are also added to the BOOTP broadcast packets when the command is configured.</li> </ul>
Step 5	<p><b>ip dhcp relay information policy encapsulate</b></p> <p><b>Example:</b></p> <pre>Router(config)# ip dhcp relay information policy encapsulate</pre>	<p>Enables the system to encapsulate the DHCP relay agent information option (option-82 field) received from a prior relay agent in forwarded BOOTREQUEST messages to a DHCP server.</p> <ul style="list-style-type: none"> <li>Option 82 information from both relay agents will be forwarded to the DHCP server.</li> </ul>
Step 6	<p><b>interface type number</b></p> <p><b>Example:</b></p> <pre>Router(config)# interface FastEthernet0/0</pre>	<p>(Optional) Configures an interface and enters interface configuration mode.</p> <ul style="list-style-type: none"> <li>If you configure the <b>ip dhcp relay information</b> command in global configuration mode, there is no need to configure the command in interface configuration mode unless you want a different configuration to apply on specific interfaces.</li> </ul>
Step 7	<p><b>ip dhcp relay information policy-action encapsulate</b></p> <p><b>Example:</b></p> <pre>Router(config-if)# ip dhcp relay information policy-action encapsulate</pre>	<p>(Optional) Enables the system to encapsulate the DHCP relay agent information option (option-82 field) received on an interface from a prior relay agent in forwarded BOOTREQUEST messages to a DHCP server on an interface.</p> <ul style="list-style-type: none"> <li>This function is disabled by default. This command has precedence over any global configuration. However, if support for the relay agent information option encapsulation support is configured in global configuration mode, but not in interface configuration mode, the interface inherits the global configuration.</li> </ul>

## Troubleshooting the DHCP Relay Agent

Perform this task to troubleshoot the DHCP relay agent.

The **show ip route dhcp** command is useful to help you understand any problems with the DHCP relay agent adding routes to clients from unnumbered interfaces. All routes added to the routing table by the DHCP server and relay agent are displayed.

### SUMMARY STEPS

1. **enable**

2. `show ip route dhcp`
3. `show ip route dhcp ip-address`
4. `show ip route vrf vrf-name dhcp`
5. `clear ip route [vrf vrf-name] dhcp [ip-address]`

## DETAILED STEPS

	Command or Action	Purpose
<b>Step 1</b>	<b>enable</b> <b>Example:</b> Device> enable	Enables privileged EXEC mode. <ul style="list-style-type: none"> <li>• Enter your password if prompted.</li> </ul>
<b>Step 2</b>	<b>show ip route dhcp</b> <b>Example:</b> Device# show ip route dhcp	Displays all routes added by the DHCP server and relay agent.
<b>Step 3</b>	<b>show ip route dhcp ip-address</b> <b>Example:</b> Device# show ip route dhcp 172.16.1.3	Displays all routes added by the DHCP server and relay agent associated with an IP address.
<b>Step 4</b>	<b>show ip route vrf vrf-name dhcp</b> <b>Example:</b> Device# show ip route vrf red dhcp	Displays all routes added by the DHCP server and relay agent associated with the named VRF.
<b>Step 5</b>	<b>clear ip route [vrf vrf-name] dhcp [ip-address]</b> <b>Example:</b> Device# clear ip route dhcp	Removes routes from the routing table added by the DHCP server and relay agent for the DHCP clients on unnumbered interfaces.

# Configuration Examples for the DHCP Relay Agent

## Example Configuring the DHCP Relay Agent and Relay Agent Information Option Support

The following example shows how to enable the DHCP server, the relay agent, and the insertion and removal of the DHCP relay information option (option 82). Note that the Cisco IOS XE DHCP server is enabled by default. In this example, the DHCP server was disabled:

```
!reenables the DHCP server
service dhcp
ip dhcp relay information option
!
```

```
interface GigabitEthernet 0/0/0
 ip address 192.168.100.1 255.255.255.0
 ip helper-address 10.55.11.3
```

## Example Configuring the DHCP Relay Agent and Relay Agent Information Option Support per Interface

The following example shows that for subscribers being serviced by the same aggregation router, the relay agent information option needs to be processed differently for Asynchronous Transfer Mode (ATM) subscribers than for Gigabit Ethernet digital subscribers. For ATM subscribers, the relay agent information option is configured to be removed from the packet by the relay agent before forwarding to the client. For Gigabit Ethernet subscribers, the connected device provides the relay agent information option, and it is configured to remain in the packet and be forwarded to the client.

```
ip dhcp relay information trust-all
interface Loopback0
 ip address 10.16.0.1 255.255.255.0
!
interface ATM 3/0/0
 no ip address
!
interface ATM 3/0/0
 ip helper-address 10.16.1.2
 ip unnumbered loopback0
 ip dhcp relay information option-insert
!
interface Loopback1
 ip address 10.18.0.1 255.255.255.0
!
interface GigabitEthernet0/0/0
 no ip address
!
interface GigabitEthernet 0/0/1
 encaps dot1q 123
 ip unnumbered loopback1
 ip helper-address 10.18.1.2
 ip dhcp relay information policy-action keep
```

## Example Configuring the Subscriber Identifier Suboption

The following example shows how to add a unique identifier to the subscriber-identifier suboption of the relay agent information option.

```
ip dhcp relay information option
!
interface Loopback0
 ip address 10.1.1.129 255.255.255.192
!
interface ATM 4/0/0
 no ip address
!
interface ATM 4/0/1 point-to-point
 ip helper-address 10.16.1.2
 ip unnumbered Loopback0
 ip dhcp relay information option subscriber-id newperson123
 atm route-bridged ip
```

```
pvc 88/800
encapsulation aal5snap
```

## Example Configuring DHCP Relay Agent Support for MPLS VPNs

In the following example, the DHCP relay agent receives a DHCP request on Gigabit Ethernet interface 0/0/0 and sends the request to the DHCP server located at IP helper address 10.44.23.7, which is associated with the VRF named red:

```
ip dhcp relay information option vpn
!
interface GigabitEthernet 0/0/0
 ip helper-address vrf red 10.44.23.7
!
```

## Example Configuring DHCP Smart Relay Agent Forwarding

In the following example, the router will forward the DHCP broadcast received on Gigabit Ethernet interface 0/0 to the DHCP server (10.55.11.3), inserting 192.168.100.1 in the giaddr field of the DHCP packet. If the DHCP server has a scope or pool configured for the 192.168.100.0/24 network, it will respond; otherwise it will not respond.

Because the **ip dhcp smart-relay** global configuration command is configured, if the router sends three requests using 192.168.100.1 in the giaddr field, and doesn't get a response, it will move on and start using 172.16.31.254 in the giaddr field instead. Without the smart relay functionality, the route only uses 192.168.100.1 in the giaddr field.

```
ip dhcp smart-relay
!
interface GigabitEthernet0/0/0
 ip address 192.168.100.1 255.255.255.0
 ip address 172.16.31.254 255.255.255.0
 ip helper-address 10.55.11.3
!
```

## Additional References

### Related Documents

Related Topic	Document Title
Cisco IOS commands	<a href="#">Cisco IOS Master Commands List, All Releases</a>
DHCP commands: complete command syntax, command modes, command history, defaults, usage guidelines, and examples	<i>Cisco IOS IP Addressing Services Command Reference</i>
DHCP conceptual information	“DHCP Overview” module
DHCP server configuration	“Configuring the Cisco IOS XE DHCP Server” module
DHCP client configuration	“Configuring the Cisco IOS XE DHCP Client” module

Related Topic	Document Title
DHCP server on-demand address pool manager configuration	“Configuring the DHCP Server On-Demand Address Pool Manager” module
DHCP advanced features	“Configuring DHCP Services for Accounting and Security” module

### Standards

Standards	Title
No new or modified standards are supported by this functionality.	--

### MIBs

MIBs	MIBs Link
No new or modified MIBs are supported, and support for existing MIBs has not been modified.	To locate and download MIBs for selected platforms, Cisco software releases, and feature sets, use Cisco MIB Locator found at the following URL: <a href="http://www.cisco.com/go/mibs">http://www.cisco.com/go/mibs</a>

### RFCs

RFCs	Title
RFC 951	<i>Bootstrap Protocol (BOOTP)</i>
RFC 1542	<i>Clarifications and Extensions for the Bootstrap Protocol</i>
RFC 2131	<i>Dynamic Host Configuration Protocol</i>
RFC 2685	<i>Virtual Private Networks Identifier</i>
RFC 3046	<i>DHCP Relay Information Option</i>

## Technical Assistance

Description	Link
<p>The Cisco Support website provides extensive online resources, including documentation and tools for troubleshooting and resolving technical issues with Cisco products and technologies.</p> <p>To receive security and technical information about your products, you can subscribe to various services, such as the Product Alert Tool (accessed from Field Notices), the Cisco Technical Services Newsletter, and Really Simple Syndication (RSS) Feeds.</p> <p>Access to most tools on the Cisco Support website requires a Cisco.com user ID and password.</p>	<a href="http://www.cisco.com/cisco/web/support/index.html">http://www.cisco.com/cisco/web/support/index.html</a>

## Feature Information for the Cisco IOS XE DHCP Relay Agent

The following table provides release information about the feature or features described in this module. This table lists only the software release that introduced support for a given feature in a given software release train. Unless noted otherwise, subsequent releases of that software release train also support that feature.

Use Cisco Feature Navigator to find information about platform support and Cisco software image support. To access Cisco Feature Navigator, go to [www.cisco.com/go/cfn](http://www.cisco.com/go/cfn). An account on Cisco.com is not required.

*Table 6: Feature Information for the Cisco IOS XE DHCP Relay Agent*

Feature Name	Releases	Feature Configuration Information
DHCP Relay Option 82 per Interface Support	Cisco IOS XE Release 2.1 Cisco IOS XE Release 3.9S	<p>This feature enables support for the DHCP relay agent information option (option 82) on a per interface basis. The interface configuration allows different DHCP servers, with different DHCP option 82 requirements to be reached from one Cisco router.</p> <p>The following commands were introduced by this feature: <b>ip dhcp relay information check-reply</b>, <b>ip dhcp relay information option-insert</b>, <b>ip dhcp relay information policy-action</b>.</p>
DHCP Subscriber Identifier Suboption of Option 82	Cisco IOS XE Release 2.1	<p>This feature enables an ISP to add a unique identifier to the subscriber-identifier suboption of the relay agent information option.</p> <p>The following command was introduced by this feature: <b>ip dhcp relay information option subscriber-id</b>.</p>



Feature Name	Releases	Feature Configuration Information
DHCP Relay MPLS VPN Support	Cisco IOS XE Release 2.1 Cisco IOS XE Release 3.9S	DHCP relay support for MPLS VPNs enables a network administrator to conserve address space by allowing overlapping addresses. The relay agent can support multiple clients on different VPNs, and many of these clients from different VPNs can share the same IP address.  The following commands were modified by this feature: <b>ip dhcp relay information option, ip helper address.</b>
DHCP Relay Agent Support for Unnumbered Interfaces	Cisco IOS XE Release 2.1 Cisco IOS XE Release 3.9S	The Cisco IOS XE DHCP relay agent supports the use of unnumbered interfaces.
DHCP Relay Option 82 Encapsulation	Cisco IOS XE Release 3.1S	This feature allows a second DHCP relay agent to encapsulate the relay agent information option (option 82) from a prior relay agent, add its own option 82, and forward the packet to the DHCP server. The DHCP server can use the VPN information from the second relay agent along with the option 82 information from the first relay agent to send correct address assignments and other configuration parameters for the client devices based on the VRF, option 60, and encapsulated option 82.  The following commands were added or modified by this feature: <b>ip dhcp relay information policy, ip dhcp relay information policy-action.</b>

## Glossary

**client** --A host trying to configure its interface (obtain an IP address) using DHCP or BOOTP protocols.

**DHCP** --Dynamic Host Configuration Protocol.

**giaddr** --Gateway IP address. The giaddr field of the DHCP message provides the DHCP server with information about the IP address subnet on which the client is to reside. It also provides the DHCP server with an IP address where the response messages are to be sent.

**MPLS** --Multiprotocol Label Switching. Emerging industry standard upon which tag switching is based.

**relay agent** --A device that forwards DHCP and BOOTP messages between a server and a client on different subnets.

**server** --DHCP or BOOTP server.

**VPN** --Virtual Private Network. Enables IP traffic to use tunneling to travel securely over a public TCP/IP network.

**VRF** --VPN routing and forwarding instance. A VRF consists of an IP routing table, a derived forwarding table, a set of interfaces that use the forwarding table, and a set of rules and routing protocols that determine what goes into the forwarding table. In general, a VRF includes the routing information that defines a customer VPN site that is attached to a PE device. Each VPN instantiated on the PE device has its own VRF.





## CHAPTER 5

# DHCP Relay Server ID Override and Link Selection Option 82 Suboptions

The DHCP Relay Server ID Override and Link Selection Option 82 Suboptions feature enables the relay agent to be part of all Dynamic Host Configuration Protocol (DHCP) message exchanges by supporting the use of two suboptions of the relay agent information option (option 82). This design allows DHCPv4 to operate in networks where direct communication between the client and server is not possible or desired. These two suboptions used together enable the deployment of an architecture where having all DHCP traffic flow through the relay agent is desirable, allowing for greater control of DHCP communications.

This feature also introduces the capability to manually configure the interface for the relay agent to use as the source IP address for messages relayed to the DHCP server. This configuration allows the network administrator to specify a stable, hardware-independent IP address (such as a loopback interface).

- [Finding Feature Information, on page 109](#)
- [Restrictions for DHCP Relay Server ID Override and Link Selection Option 82 Suboptions, on page 110](#)
- [Information About DHCP Relay Server ID Override and Link Selection Option 82 Suboptions, on page 110](#)
- [How to Configure Support for the DHCP Relay Server ID Override and Link Selection Suboptions, on page 112](#)
- [Configuration Examples for DHCP Relay Server ID Override and Link Selection Option 82 Suboptions, on page 114](#)
- [Additional References for DHCP Relay Server ID Override and Link Selection Option 82 Suboptions, on page 115](#)
- [Feature Information for DHCP Relay Server ID Override and Link Selection Option 82 Suboptions, on page 116](#)
- [Glossary, on page 116](#)

## Finding Feature Information

Your software release may not support all the features documented in this module. For the latest caveats and feature information, see [Bug Search Tool](#) and the release notes for your platform and software release. To find information about the features documented in this module, and to see a list of the releases in which each feature is supported, see the feature information table.

Use Cisco Feature Navigator to find information about platform support and Cisco software image support. To access Cisco Feature Navigator, go to [www.cisco.com/go/cfn](http://www.cisco.com/go/cfn). An account on Cisco.com is not required.

# Restrictions for DHCP Relay Server ID Override and Link Selection Option 82 Suboptions

If the DHCP Relay Server ID Override and Link Selection Option 82 Suboptions feature and the DHCP Relay MPLS VPN Support feature are both configured, the DHCP Relay MPLS VPN Support feature takes precedence.

## Information About DHCP Relay Server ID Override and Link Selection Option 82 Suboptions

### Server ID Override Suboption

The server identifier (ID) override suboption allows the DHCP relay agent to specify a new value for the server ID option, which is inserted by the Dynamic Host Configuration Protocol (DHCP) server in the reply packet. This suboption allows the DHCP relay agent to act as the actual DHCP server such that the renew requests will come to the relay agent rather than the DHCP server directly. The server ID override suboption contains the incoming interface IP address, which is the IP address on the relay agent that is accessible from the client. The DHCP client uses this information to send all renew and release request packets to the relay agent. The relay agent adds all of the appropriate suboptions and then forwards the renew and release request packets to the original DHCP server.

### Link Selection Suboption

The link selection suboption provides a mechanism to separate the subnet/link on which the DHCP client resides from the gateway address (giaddr), which can be used to communicate with the relay agent by the DHCP server. The relay agent will set the suboption to the correct subscriber subnet and the DHCP server will use that value to assign an IP address rather than the giaddr value. The relay agent will set the giaddr to its own IP address so that DHCP messages are routable over the network.

## DHCP Relay Server ID Override and Link Selection Option 82 Suboptions Feature Design

The Dynamic Host Configuration Protocol (DHCP) IPv4 deployment model assumes a single routing domain between the DHCP client and DHCP server. In some network designs, the DHCP server cannot directly communicate with DHCP clients. Customers may choose this design to make critical infrastructure servers inaccessible and to protect the DHCP server from client attacks.

Relay agents are used to forward requests and replies between clients and servers when they are not on the same physical subnet. In all cases, the DHCP relay agent must be able to communicate directly with both the DHCP server and DHCP client. By using the relay agent information option (option 82), the DHCP relay agent can include additional information about itself when forwarding client-originated DHCP packets to a DHCP server.

The DHCP Relay Server ID Override and Link Selection Option 82 Suboptions feature enables the relay agent to be part of all DHCP message exchanges by supporting the use of two suboptions of option 82: server ID override and link selection. This design results in all DHCP messages flowing through the relay agent, allowing for greater control of DHCP communications.

Communication from the DHCP server through the relay agent can be an issue. If the server needs to reach the client, it must do so through the relay agent. The IP address of the relay agent might not be ideal. For example, if the network is renumbered or if the interface at the relay agent is down for some reason, the server may not be able to reach the client. This feature introduces the capability to manually configure the interface for the relay agent to use as the source IP address for messages relayed to the DHCP server. This configuration allows the network administrator to specify a stable, hardware-independent IP address (such as a loopback interface).

The figure and the numbered list that follows it shows the processing that occurs on the DHCP relay agent and DHCP server when this feature is configured.

**Figure 8: DHCP Relay Agent and DHCP Server Processing of Option 82 Suboptions**

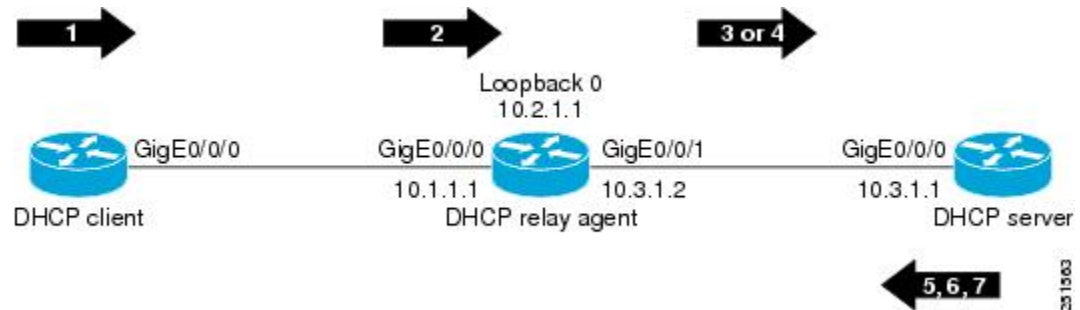

1. The DHCP client generates a DHCP request and broadcasts it on the network.
2. The DHCP relay agent intercepts the broadcast DHCP request packet and inserts a server ID override suboption and link selection suboption to its relay agent information option in the DHCP packet. The server ID override and link selection suboptions contain the incoming interface IP address, which is the IP address on the relay agent that is accessible from the client (10.1.1.1 in this case).
3. The relay agent sets the gateway IP address (giaddr) to the IP address of an interface that is reachable by the DHCP server (typically the server-facing interface that will be used to transmit the message, 10.3.1.2 in this case).
4. If the source interface is explicitly configured on a loopback interface (using the **ip dhcp-relay source-interface** command), the relay agent will use that address as the source IP address (giaddr) for messages relayed to the DHCP server (10.2.1.1 in this case).

The following processing occurs on the DHCP server after receiving the forwarded packets from the relay agent:

1. The DHCP server uses the link selection suboption to locate the correct address pools for the DHCP client.
2. The DHCP server sets the server ID option to the value specified by the server ID override suboption of the DHCP packet.
3. The DHCP server sends the reply message to the IP address specified in the giaddr.

The DHCP client will see the relay agent address as the server ID and use that address when unicasting RENEW messages.

# How to Configure Support for the DHCP Relay Server ID Override and Link Selection Suboptions

## Configuring the DHCP Relay Agent to Insert the DHCP Server ID Override and Link Selection Suboptions into Option 82



**Note** If the DHCP Relay Server ID Override and Link Selection Option 82 Suboptions feature and the DHCP Relay MPLS VPN Support feature are both configured, the DHCP Relay MPLS VPN Support feature takes precedence.

### SUMMARY STEPS

1. **enable**
2. **configure terminal**
3. **ip dhcp-relay information option server-override**
4. **ip dhcp-relay source-interface** *type number*
5. **interface** *type number*
6. **ip dhcp relay information option server-id-override**
7. **ip dhcp relay source-interface** *type number*
8. **end**

### DETAILED STEPS

	Command or Action	Purpose
<b>Step 1</b>	<b>enable</b> <b>Example:</b> Device> enable	Enables privileged EXEC mode. <ul style="list-style-type: none"> <li>• Enter your password if prompted.</li> </ul>
<b>Step 2</b>	<b>configure terminal</b> <b>Example:</b> Device# configure terminal	Enters global configuration mode.
<b>Step 3</b>	<b>ip dhcp-relay information option server-override</b> <b>Example:</b> Device(config)# ip dhcp-relay information option server-override	Enables the system to globally insert the server ID override and link selection suboptions into the DHCP relay agent information option in forwarded BOOTREQUEST messages to a Dynamic Host Configuration Protocol (DHCP) server. <ul style="list-style-type: none"> <li>• If the <b>ip dhcp relay information option server-id-override</b> command is configured on an</li> </ul>

	Command or Action	Purpose
		interface, it overrides the global configuration on that interface only.
<b>Step 4</b>	<p><b>ip dhcp-relay source-interface</b> <i>type number</i></p> <p><b>Example:</b></p> <pre>Device(config)# ip dhcp-relay source-interface loopback 0</pre>	<p>(Optional) Globally configures the source interface for the relay agent to use as the source IP address for relayed messages.</p> <ul style="list-style-type: none"> <li>• This command allows the network administrator to specify a stable, hardware-independent IP address (such as a loopback interface).</li> <li>• If the <b>ip dhcp relay source-interface</b> command is configured on an interface, it overrides the global configuration on that interface only.</li> </ul>
<b>Step 5</b>	<p><b>interface</b> <i>type number</i></p> <p><b>Example:</b></p> <pre>Device(config)# interface GigabitEthernet 0/0/0</pre>	(Optional) Configures an interface and enters interface configuration mode.
<b>Step 6</b>	<p><b>ip dhcp relay information option server-id-override</b></p> <p><b>Example:</b></p> <pre>Device(config-if)# ip dhcp relay information option server-id-override</pre>	(Optional) Enables the system to insert the server ID override and link selection suboptions on a specific interface into the DHCP relay agent information option in forwarded BOOTREQUEST messages to a DHCP server.
<b>Step 7</b>	<p><b>ip dhcp relay source-interface</b> <i>type number</i></p> <p><b>Example:</b></p> <pre>Device(config-if)# ip dhcp relay source-interface loopback 2</pre>	(Optional) Configures the source interface for the relay agent to use as the source IP address for relayed messages.
<b>Step 8</b>	<p><b>end</b></p> <p><b>Example:</b></p> <pre>Device(config-if)# end</pre>	Exits interface configuration mode and returns to privileged EXEC mode.

# Configuration Examples for DHCP Relay Server ID Override and Link Selection Option 82 Suboptions

## Example: DHCP Relay Server ID Override and Link Selection Option 82 Suboptions

In the following example, the IP address of the loopback interface is used as the source IP address for relayed messages. The client initiates IP address negotiation from GigabitEthernet interface 0/0/0. The Dynamic Host Configuration Protocol (DHCP) relay agent is configured globally to insert the server ID override suboption and link selection suboption into the relay agent information option of the DHCP packet. The relay agent uses the server ID override suboption to force the DHCP server to use that value as the server ID in the DHCP message. The DHCP server uses the link selection suboption to determine from which subnet to assign an IP address.

### DHCP Client

```
interface GigabitEthernet 0/0/0
 ip address dhcp
```

### DHCP Relay Agent

```
ip dhcp-relay information option server-override
ip dhcp-relay source-interface loopback 0
!
interface Loopback0
 ip address 10.2.1.1 255.255.255.0
!
interface GigabitEthernet 0/0/0
 ip address 10.1.1.1 255.255.255.0
 ip helper-address 10.3.1.1
!
interface GigabitEthernet 1/0/0
 ip address 10.3.1.2 255.255.255.0
```

### DHCP Server

```
ip dhcp excluded-address 10.3.0.1
ip dhcp pool pool1
 network 10.1.1.0 255.255.255.0
 lease 0 0 1
!
interface GigabitEthernet 0/0/0
 ip address 10.3.1.1 255.255.255.0
```



# Additional References for DHCP Relay Server ID Override and Link Selection Option 82 Suboptions

## Related Documents

Related Topic	Document Title
Cisco IOS commands	<a href="#">Cisco IOS Master Command List, All Releases</a>
IP addressing commands	<a href="#">Cisco IOS IP Addressing Services Command Reference</a>
DHCP conceptual information	<i>DHCP Overview</i>
DHCP server configuration tasks, examples, and conceptual information	<i>Configuring the Cisco IOS DHCP Server</i>
DHCP relay agent configuration tasks, examples, and conceptual information	<i>Configuring the Cisco IOS DHCP Relay Agent</i>

## Standards and RFCs

Standard/RFC	Title
RFC 3527	<i>Link Selection Suboption</i>
RFC 5107	<i>DHCP Server Identifier Override Suboption</i>

## Technical Assistance

Description	Link
The Cisco Support and Documentation website provides online resources to download documentation, software, and tools. Use these resources to install and configure the software and to troubleshoot and resolve technical issues with Cisco products and technologies. Access to most tools on the Cisco Support and Documentation website requires a Cisco.com user ID and password.	<a href="http://www.cisco.com/cisco/web/support/index.html">http://www.cisco.com/cisco/web/support/index.html</a>

## Feature Information for DHCP Relay Server ID Override and Link Selection Option 82 Suboptions

The following table provides release information about the feature or features described in this module. This table lists only the software release that introduced support for a given feature in a given software release train. Unless noted otherwise, subsequent releases of that software release train also support that feature.

Use Cisco Feature Navigator to find information about platform support and Cisco software image support. To access Cisco Feature Navigator, go to [www.cisco.com/go/cfn](http://www.cisco.com/go/cfn). An account on Cisco.com is not required.

*Table 7: Feature Information for DHCP Relay Server ID Override and Link Selection Option 82 Suboptions*

Feature Name	Releases	Feature Configuration Information
DHCP Relay Server ID Override and Link Selection Option 82 Suboptions		<p>The DHCP Relay Server ID Override and Link Selection Option 82 Suboptions feature enables the relay agent to be part of all Dynamic Host Configuration Protocol (DHCP) message exchanges by supporting the use of two suboptions of the relay agent information option (option 82). This design allows DHCPv4 to operate in networks where direct communication between the client and server is not possible or desired. These two suboptions used together enable the deployment of an architecture where having all DHCP traffic flow through the relay agent is desirable, allowing for greater control of DHCP communications.</p> <p>The following commands were introduced or modified: <b>ip dhcp relay information option server-id-override</b>, <b>ip dhcp relay source-interface</b>, <b>ip dhcp-relay information option server-override</b>, <b>ip dhcp-relay source-interface</b>.</p>

## Glossary

**client**—A host trying to configure its interface (obtain an IP address) using DHCP or BOOTP protocols.

**DHCP**—Dynamic Host Configuration Protocol.

**DHCP options and suboptions**—Configuration parameters and other control information are carried in tagged data items that are stored in the options field of the DHCP message. Options provide a method of appending additional information. Vendors that want to provide additional information to their client not designed into the protocol can use options.

**giaddr**—Gateway IP address field of the DHCP packet. The giaddr provides the DHCP server with information about the IP address subnet in which the client resides. The giaddr also provides the DHCP server with an IP address where the DHCP response messages can be sent.

**relay agent**—A router that forwards DHCP and BOOTP messages between a server and a client on different subnets.



## CHAPTER 6

# DHCP Server RADIUS Proxy

---

The Dynamic Host Configuration Protocol (DHCP) Server RADIUS Proxy is a RADIUS-based address assignment mechanism in which a DHCP server authorizes remote clients and allocates addresses based on replies from a RADIUS server.

- [Finding Feature Information, on page 117](#)
- [Prerequisites for DHCP Server RADIUS Proxy, on page 117](#)
- [Restrictions for DHCP Server RADIUS Proxy, on page 118](#)
- [Information About DHCP Server RADIUS Proxy, on page 118](#)
- [How to Configure DHCP Server RADIUS Proxy, on page 121](#)
- [Configuration Examples for DHCP Server Radius Proxy, on page 127](#)
- [Additional References, on page 128](#)
- [Technical Assistance, on page 129](#)
- [Feature Information for DHCP Server RADIUS Proxy, on page 129](#)
- [Glossary, on page 130](#)

## Finding Feature Information

Your software release may not support all the features documented in this module. For the latest caveats and feature information, see [Bug Search Tool](#) and the release notes for your platform and software release. To find information about the features documented in this module, and to see a list of the releases in which each feature is supported, see the feature information table.

Use Cisco Feature Navigator to find information about platform support and Cisco software image support. To access Cisco Feature Navigator, go to [www.cisco.com/go/cfn](http://www.cisco.com/go/cfn). An account on Cisco.com is not required.

## Prerequisites for DHCP Server RADIUS Proxy

Before you can configure the DHCP Server RADIUS Proxy, you must be running DHCPv4 or a later version. For information about release and platform support, see "Feature Information for DHCP Server RADIUS Proxy".

# Restrictions for DHCP Server RADIUS Proxy

The DHCP Server RADIUS Proxy supports only one address authorization pool on the router.

## Information About DHCP Server RADIUS Proxy

### DHCP Server RADIUS Proxy Overview

The DHCP Server RADIUS Proxy feature is an address allocation mechanism for RADIUS-based authorization of DHCP leases. This feature supports DHCP options 60 and 121.

1. The DHCP server passes client information to a RADIUS server.
2. The RADIUS server returns all required information to the DHCP server as RADIUS attributes.
3. The DHCP server translates the RADIUS attributes into DHCP options, and sends this information back to RADIUS in a DHCP OFFER message.
4. DHCP binding is synchronized after the RADIUS server authorizes the client session.

If a local pool and an authorization pool are configured on the router, the DHCP server can assign addresses from both pools for different client interfaces.

### DHCP Server RADIUS Proxy Architecture

The allocation of addresses in a DHCP and RADIUS solution occurs as follows:

1. The client accesses the network from a residential gateway and sends a DHCP DISCOVER broadcast message to the relay agent. The DHCP DISCOVER message contains the client IP address, hostname, vendor class identifier, and client identifier.
2. The relay agent sends a DHCP DISCOVER unicast message containing the following information to the router:
  - Relay agent information (option 82) with the remote ID suboption containing the inner and outer VLAN IDs
  - Client information in the DHCP DISCOVER packet

The router determines the address of the DHCP server from the IP helper address on the interface that receives the DHCP packet.

1. RADIUS receives an access-request message to translate the DHCP options to RADIUS attributes.
2. RADIUS responds with an access-accept message, and delivers the following attributes to the DHCP server:
  - Framed-IP-Address
  - Framed-IP-Netmask
  - Session-Timeout
  - Session-Duration

3. The DHCP server sends an OFFER unicast message containing the following translations from the RADIUS server access-accept message to the client:
  - Framed-IP-Address inserted into the DHCP header.
  - Framed-IP-Netmask inserted into DHCP option 1 (subnet mask).
  - Session-Timeout inserted into DHCP option 51 (IP address lease time).
  - Framed-Route that is translated from the standard Cisco Framed-Route format into DHCP option 121 or the DHCP default gateway option (if the network and netmask are appropriate for a default route).
  - A copy of relay agent information (option 82). Before the DHCP client receives the packet, the relay removes option 82.
  - T1 time set to the Session-Timeout and T2 time set to the Session-Duration.
4. The client returns a formal request for the offered IP address to the DHCP server in a DHCP REQUEST broadcast message.
5. The DHCP confirms that the IP address is allocated to the client by returning a DHCP ACK unicast message containing lease information and the DHCP options to the client.
6. A RADIUS server accounting request starts, followed by a RADIUS server accounting response that is used by the AAA subsystem.

When a RADIUS server attribute is not present in an access-accept message, the corresponding DHCP option is not sent to the DHCP client. If the required information to produce a particular RADIUS server attribute is not available to the DHCP server, the DHCP server does not include information in the RADIUS packet. Non-inclusion can be in the form of not sending an attribute (if there is no information at all), or omitting information from the attribute (in the case of CLI-based format strings).

If a DHCP option is provided to the DHCP server but is invalid, the DHCP server may not transmit the corresponding RADIUS attribute in the access-request, or may transmit an invalid RADIUS server attribute.

## DHCP Server and RADIUS Translations

The table below lists the translations of DHCP options in a DHCP DISCOVER message to attributes in a RADIUS server access-request message.

**Table 8: DHCP DISCOVER to RADIUS Access-Request Translations**

DHCP DISCOVER	RADIUS Access-Request
Virtual MAC address of the residential gateway	User-Name
Not Applicable	User-Password as configured on the DHCP server
Gateway address of the relay agent (giaddr field of a DHCP packet)	NAS-identifier
Hostname	Cisco AV pair client-hostname that equals the value of DHCP option 12
Vendor class	Cisco AV pair dhcp-vendor-class that equals a hexadecimal-encoded value of DHCP option 60

DHCP DISCOVER	RADIUS Access-Request
Client identifier	Cisco AV pair dhcp-client-id that equals the hexadecimal-encoded value of DHCP option 61
DHCP relay information option that can contain VLAN parameter on the D-router	Cisco AV pair dhcp-relay-info that equals the hexadecimal-encoded value of DHCP option 82

The table below lists the translations of attributes in a RADIUS server access-accept message to DHCP options in a DHCP OFFER message.

**Table 9: RADIUS Access-Accept to DHCP OFFER Translations**

RADIUS Access-Accept	DHCP OFFER
Framed-IP-Address	IP address of the residential gateway
Framed-IP-Netmask	Subnet mask (option 1)
Session-Timeout	IP address lease time (option 51)
Cisco AV pair session-duration in seconds, where seconds is greater than or equal to the number of seconds in the Session-Timeout attribute.	Provides session control on the DHCP server. This attribute is not transmitted to the DHCP client.
Framed-Route (RADIUS attribute 22). One route for each DHCP option is allowed with a maximum of 16 Framed-Route options for a RADIUS packet.	Contains up to 16 classless routes in one option (option 121)

## RADIUS Profiles for DHCP Server RADIUS Proxy

When you configure RADIUS server user profiles for DHCP server RADIUS proxy, use the following guidelines:

- The Session-Timeout attribute must contain a value, in seconds. If this attribute is not present, the DHCP OFFER is not sent to the client.
- A RADIUS user profile must contain the following attributes:
  - Framed-IP-Address
  - Framed-IP-Netmask
  - Framed-Route
  - Session-Timeout
  - Session-Duration--Session-Duration is the Cisco AV pair session-duration = seconds, where seconds is the maximum time for the duration of a lease including all renewals. The value for Session-Duration must be greater than or equal to the Session-Timeout attribute value, and it cannot be zero.
- Additional RADIUS server attributes are allowed but are not required. The DHCP server ignores additional attributes that it does not understand. If a RADIUS server user profile contains a required attribute that is empty, the DHCP server does not generate the DHCP options.

# How to Configure DHCP Server RADIUS Proxy

## Configuring the DHCP Server for RADIUS-based Authorization

Perform this task on the DHCP server to configure address allocation for RADIUS-based authorization of DHCP leases.

### SUMMARY STEPS

1. **enable**
2. **configure terminal**
3. **service dhcp**
4. **aaa new-model**
5. **aaa group server radius** *group-name*
6. **server** *ip-address* [**auth-port** *port-number*] [**acct-port** *port-number*]
7. **exit**
8. **aaa authorization network** *method-list-name* **group** *group-name*
9. **aaa accounting network** *method-list-name* **start-stop** **group** *group-name*
10. **ip dhcp pool** *name*
11. **accounting** *method-list-name*
12. **authorization method** *method-list-name*
13. **authorization shared-password** *password*
14. **authorization username** *string*
15. **exit**
16. **interface** *type slot / subslot / port* [*.subinterface*]
17. **encapsulation dot1q** *vlan-id* **second-dot1q** {**any** | *vlan-id*[, *vlan-id*[- *vlan-id*]]}
18. **ip address** *address mask*
19. **no shutdown**
20. **radius-server host** *ip-address* [**auth-port** *port-number*] [**acct-port** *port-number*]
21. **radius-server key** {*0 string* | *7 string* | *string*}
22. **exit**

### DETAILED STEPS

	Command or Action	Purpose
Step 1	<b>enable</b> <b>Example:</b> <pre>Router&gt; enable</pre>	Enables privileged EXEC mode. <ul style="list-style-type: none"> <li>• Enter your password if prompted.</li> </ul>
Step 2	<b>configure terminal</b> <b>Example:</b> <pre>Router# configure terminal</pre>	Enters global configuration mode.

	Command or Action	Purpose
<b>Step 3</b>	<b>service dhcp</b> <b>Example:</b> Router(config)# <b>service dhcp</b>	Enables DHCP server and relay agent features on the router. By default, these features are enabled on the router.
<b>Step 4</b>	<b>aaa new-model</b> <b>Example:</b> Router(config)# <b>aaa new-model</b>	Enables the authentication, authorization, and accounting (AAA) access control system.
<b>Step 5</b>	<b>aaa group server radius <i>group-name</i></b> <b>Example:</b> Router(config)# <b>aaa group server radius group1</b>	Specifies the name of the server host list to group RADIUS server hosts. Enters server-group configuration mode. <i>group-name</i> --Character string to name the server group. The following words cannot be used as group name: <ul style="list-style-type: none"> <li>• auth-guest</li> <li>• enable</li> <li>• guest</li> <li>• if-authenticated</li> <li>• if-needed</li> <li>• krb5</li> <li>• krb-instance</li> <li>• krb-telnet</li> <li>• line</li> <li>• local</li> <li>• none</li> <li>• radius</li> <li>• rcmd</li> <li>• tacacs</li> <li>• tacacsplus</li> </ul>
<b>Step 6</b>	<b>server <i>ip-address</i> [auth-port <i>port-number</i>] [acct-port <i>port-number</i>]</b> <b>Example:</b> Router(config-sg)# <b>server 10.1.1.1 auth-port 1700 acct-port 1701</b>	Specifies the IP address of the RADIUS server host for the defined server group. Repeat this command for each RADIUS server host to associate with the server group. <ul style="list-style-type: none"> <li>• <i>ip-address</i>-- IP address of the RADIUS server host.</li> <li>• <b>auth-port <i>port-number</i></b>-- (Optional) Specifies the UDP destination port for authentication requests. Default value is 1645.</li> </ul>



	Command or Action	Purpose
		<ul style="list-style-type: none"> <li>• <b>acct-port</b> <i>port-number</i>-- (Optional) Specifies the UDP destination port for accounting requests. Default value is 1646.</li> </ul>
<b>Step 7</b>	<b>exit</b> <b>Example:</b> <pre>Router(config-sg) # exit</pre>	Exits server-group configuration mode.
<b>Step 8</b>	<b>aaa authorization network</b> <i>method-list-name</i> <b>group</b> <i>group-name</i> <b>Example:</b> <pre>Router(config) # aaa authorization network auth1 group group1</pre>	Specifies the methods list and server group for DHCP authorization. <ul style="list-style-type: none"> <li>• <b>method-list-name</b> --Character string to name the authorization methods list.</li> <li>• <b>group</b> --Specifies a server group.</li> <li>• <b>group-name</b> --Name of the server group to apply to DHCP authorization.</li> </ul>
<b>Step 9</b>	<b>aaa accounting network</b> <i>method-list-name</i> <b>start-stop</b> <i>group</i> <i>group-name</i> <b>Example:</b> <pre>Router(config) # aaa accounting network acct1 start-stop group group1</pre>	Specifies that AAA accounting runs for all network service requests. <ul style="list-style-type: none"> <li>• <b>method-list-name</b> --Character string to name the accounting methods list.</li> <li>• <b>start-stop</b> --Sends a start accounting notice at the beginning of a process and a stop accounting notice at the end of a process. The start accounting record is sent in the background. The requested user process begins regardless of whether or not the start accounting notice is received by the accounting server.</li> <li>• <b>group</b> --Specifies a server group.</li> <li>• <b>group-name</b> --Name of the server group to apply to DHCP accounting.</li> </ul>
<b>Step 10</b>	<b>ip dhcp pool</b> <i>name</i> <b>Example:</b> <pre>Router(config) # ip dhcp pool pool1</pre>	Specifies a name for the DHCP server address pool. Enters DHCP pool configuration mode. <ul style="list-style-type: none"> <li>• <b>name</b> --Name of the pool.</li> </ul>
<b>Step 11</b>	<b>accounting</b> <i>method-list-name</i> <b>Example:</b> <pre>Router(config-dhcp) # accounting acct1</pre>	Enables DHCP accounting. <ul style="list-style-type: none"> <li>• <b>method-list-name</b> --Name of the accounting methods list.</li> </ul>
<b>Step 12</b>	<b>authorization method</b> <i>method-list-name</i>	Enables DHCP authorization.

	Command or Action	Purpose
	<p><b>Example:</b></p> <pre>Router (config-dhcp) # authorization method auth1</pre>	<ul style="list-style-type: none"> <li>• <i>method-list-name</i> --Name of the authorization methods list.</li> </ul>
<b>Step 13</b>	<p><b>authorization shared-password</b> password</p> <p><b>Example:</b></p> <pre>Router (config-dhcp) # authorization shared-password cisco</pre>	Specifies the password that is configured in the RADIUS user profile.
<b>Step 14</b>	<p><b>authorization username</b> string</p> <p><b>Example:</b></p> <pre>Router (config-dhcp) # authorization username %%c-user1</pre>	<p>Specifies the parameters that RADIUS sends to a DHCP server when downloading configuration information for a DHCP client.</p> <p>The <i>string</i> command argument contains the following formatting characters to insert DHCP client information:</p> <ul style="list-style-type: none"> <li>• <b>%c-</b> --Ethernet address of the DHCP client (chaddr field)</li> <li>• <b>%i-</b> --Inner VLAN ID from the DHCP relay information (option 82)</li> <li>• <b>%o---</b>Outer VLAN ID from the DHCP relay information (option 82)</li> <li>• <b>%p</b> --Port number from the DHCP relay information (option 82)</li> <li>• <b>%g</b> --Gateway address of the DHCP relay agent (giaddr field)</li> <li>• <b>%%</b> --Transmits the percent sign (%) character in the string sent to the RADIUS server</li> </ul> <p><b>Note</b> The percent (%) is a marker to insert the DHCP client information associated with the specified character. The % is not sent to the RADIUS server unless you specify the %% character.</p>
<b>Step 15</b>	<p><b>exit</b></p> <p><b>Example:</b></p> <pre>Router (config-dhcp) # exit</pre>	Exits DHCP pool configuration mode.
<b>Step 16</b>	<p><b>interface</b> <i>type slot / subslot / port</i> [<i>.subinterface</i>]</p> <p><b>Example:</b></p> <pre>Router (config) # interface ethernet 1/10.0</pre>	Configures an interface or subinterface that allows the DHCP client to obtain an IP address from the DHCP server. Enters interface or subinterface configuration mode.

	Command or Action	Purpose
Step 17	<p><b>encapsulation dot1q</b> <i>vlan-id</i> <b>second-dot1q</b> {<i>any</i>   <i>vlan-id</i>[, <i>vlan-id</i>[- <i>vlan-id</i>]]}</p> <p><b>Example:</b></p> <pre>Router(config-subif)# encapsulation dot1q 100 second-dot1q 200</pre>	<p>(Optional) Enables IEEE 802.1Q encapsulation of traffic on a subinterface in a virtual LAN (VLAN).</p> <ul style="list-style-type: none"> <li>• <i>vlan-id</i> --VLAN ID, integer in the range 1 to 4094. To separate the starting and ending VLAN ID values that are used to define a range of VLAN IDs, enter a hyphen. (Optional) To separate each VLAN ID range from the next range, enter a comma.</li> <li>• <i>second-dot1q</i>--Supports the IEEE 802.1Q-in-Q VLAN Tag Termination feature to configure an inner VLAN ID.</li> <li>• <b>any</b> --Any second tag in the range 1 to 4094.</li> </ul>
Step 18	<p><b>ip address</b> <i>address mask</i></p> <p><b>Example:</b></p> <pre>Router(config-if)# ip address 192.168.1.1 255.255.255.0</pre>	<p>Specifies an IP address for an interface or subinterface.</p> <ul style="list-style-type: none"> <li>• <i>address</i> is the IP address of the interface or subinterface.</li> <li>• <i>mask</i> is the subnet address for the IP address.</li> </ul>
Step 19	<p>no shutdown</p> <p><b>Example:</b></p> <pre>Router(config-if)# no shutdown</pre>	<p>Enables the interface or subinterface.</p>
Step 20	<p><b>radius-server host</b> <i>ip-address</i> [<b>auth-port</b> <i>port-number</i>] [<b>acct-port</b> <i>port-number</i>]</p> <p><b>Example:</b></p> <pre>Router(config)# radius-server host 10.1.1.1</pre>	<p>Specifies a RADIUS server host.</p> <ul style="list-style-type: none"> <li>• <i>ip-address</i> is the IP address of the RADIUS server host.</li> <li>• <b>auth-port</b> <i>port-number</i>-- (Optional) Specifies the UDP destination port for authentication requests. Default value is 1645.</li> <li>• <b>acct-port</b> <i>port-number</i>-- (Optional) Specifies the UDP destination port for accounting requests. Default value is 1646.</li> </ul>
Step 21	<p><b>radius-server key</b> {<i>0 string</i>   <i>7 string</i>   <i>string</i>}</p> <p><b>Example:</b></p> <pre>Router(config)# radius-server key cisco</pre>	<p>Specifies the authentication and encryption key for all RADIUS communications between the router and the RADIUS daemon.</p> <ul style="list-style-type: none"> <li>• <b>0 string</b>-- Specifies an unencrypted (cleartext) shared key</li> <li>• <b>7 string</b> -- Specifies a hidden shared key.</li> </ul>

	Command or Action	Purpose
		<b>Note</b> Any key you enter must match the key on the RADIUS daemon. All leading spaces are ignored, but spaces within and at the end of the key are used. If you use spaces in your key, do not enclose the key in quotation marks unless the quotation marks are part of the key.
<b>Step 22</b>	<code>exit</code>	Exits global configuration mode.

## Monitoring and Maintaining the DHCP Server

Perform this task to verify and monitor DHCP server information:

### SUMMARY STEPS

1. `enable`
2. `debug ip dhcp server packet`
3. `debug ip dhcp server events`
4. `show ip dhcp binding [address]`
5. `show ip dhcp server statistics`
6. `show ip dhcp pool [name]`
7. `show ip route dhcp [address]`

### DETAILED STEPS

	Command or Action	Purpose
<b>Step 1</b>	<b>enable</b> <b>Example:</b> <pre>Router&gt; enable</pre>	Enables privileged EXEC mode. <ul style="list-style-type: none"> <li>• Enter your password if prompted.</li> </ul>
<b>Step 2</b>	<b>debug ip dhcp server packet</b> <b>Example:</b> <pre>Router# debug ip dhcp server packet</pre>	(Optional) Enables DHCP server debugging.
<b>Step 3</b>	<b>debug ip dhcp server events</b> <b>Example:</b> <pre>Router# debug ip dhcp server events</pre>	(Optional) Reports DHCP server events, such as address assignments and database updates.
<b>Step 4</b>	<b>show ip dhcp binding [address]</b> <b>Example:</b> <pre>Router# show ip dhcp binding</pre>	(Optional) Displays a list of all bindings created on a specific DHCP server. <ul style="list-style-type: none"> <li>• Use the <b>show ip dhcp binding</b> command to display the IP addresses that have already been assigned. Verify that the address pool has not been exhausted.</li> </ul>

	Command or Action	Purpose
		<p>If necessary, re-create the pool to create a larger pool of addresses.</p> <ul style="list-style-type: none"> <li>• Use the <b>show ip dhcp binding</b> command to display the lease expiration date and time of the IP address of the host.</li> </ul>
<b>Step 5</b>	<p><b>show ip dhcp server statistics</b></p> <p><b>Example:</b></p> <pre>Router# show ip dhcp server statistics</pre>	(Optional) Displays count information about server statistics and messages sent and received.
<b>Step 6</b>	<p><b>show ip dhcp pool [name]</b></p> <p><b>Example:</b></p> <pre>Router# show ip dhcp pool</pre>	(Optional) Displays the routes added to the routing table by the DHCP server and relay agent.
<b>Step 7</b>	<p><b>show ip route dhcp [address]</b></p> <p><b>Example:</b></p> <pre>Router# show ip route dhcp [address]</pre>	(Optional) Displays information about DHCP address pools.

## Configuration Examples for DHCP Server Radius Proxy

### Configuring the DHCP Server Example

The following example shows how to configure a DHCP server for RADIUS-based authorization of DHCP leases. In this example, DHCP clients can attach to Ethernet interface 4/0/1 and Ethernet subinterface 4/0/3.10. The username string (%c-user1) specifies that the RADIUS server sends the Ethernet address of DHCP client named user1 to the DHCP server.

```
Router> enable
Router# configure terminal
Router(config)# service dhcp
Router(config)# aaa new-model
Router(config)# aaa group server radius rad1
Router(config-sg)# server 10.1.1.1
Router(config-sg)# server 10.1.5.10
Router(config-sg)# exit
Router(config)# aaa authorization network auth1 group group1
Router(config)# aaa accounting network acct1 start-stop group group1
Router(config)# aaa session-id common
Router(config)# ip dhcp database tftp://172.16.1.1/router-dhcp write-delay 100 timeout 5
!
Router(config)# ip dhcp pool pool_common
Router(config-dhcp)# accounting acct1
Router(config-dhcp)# authorization method auth1
Router(config-dhcp)# authorization shared-password cisco
```

```

Router(config-dhcp)# authorization username %c-user1
Router(config-dhcp)# exit
!
Router(config)# interface ethernet4/0/1
Router(config-if)# ip address 15.0.0.1 255.255.255.0
Router(config-if)# exit
Router(config-if)# interface ethernet4/0/3.10

Router(config-if)# encapsulation dot1q 100 second-dot1q 200
Router(config-if)# ip address 10.1.1.1 255.255.255.0
Router(config-if)# exit
Router(config)# radius-server host 10.1.3.2
Router(config)# radius-server key cisco
Router(config)# exit

```

## Configuring RADIUS Profiles Example

The following example shows how to configure a typical RADIUS user profile to send attributes in an access-accept message to the DHCP server:

```

DHCP-00059A3C7800 Password = "metta"
Service-Type = Framed,
Framed-Ip-Address = 10.3.4.5,
Framed-Netmask = 255.255.255.0,
Framed-Route = "0.0.0.0 0.0.0.0 10.3.4.1",
Session-Timeout = 3600,
Cisco:Cisco-Avpair = "session-duration=7200"

```

## Additional References

The following sections provide references related to the DHCP Server RADIUS Proxy feature.

### Related Documents

Related Topic	Document Title
DHCP relay configuration	<i>Configuring the Cisco IOS XE DHCP Relay Agent</i>
DHCP commands: complete command syntax, command mode, command history, defaults, usage guidelines, and examples	<i>Cisco IOS IP Addressing Services Command Reference</i>

### Standards

Standards	Title
No new or modified standards are supported by this functionality.	--

**MIBs**

MIBs	MIBs Link
No new or modified MIBs are supported by this feature, and support for existing MIBs has not been modified by this feature.	To locate and download MIBs for selected platforms, Cisco IOS XE software releases, and feature sets, use Cisco MIB Locator found at the following URL: <a href="http://www.cisco.com/go/mibs">http://www.cisco.com/go/mibs</a>

**RFCs**

RFCs	Title
No new or modified RFCs are supported by this feature, and support for existing RFCs was not modified by this feature.	--

## Technical Assistance

Description	Link
<p>The Cisco Support website provides extensive online resources, including documentation and tools for troubleshooting and resolving technical issues with Cisco products and technologies.</p> <p>To receive security and technical information about your products, you can subscribe to various services, such as the Product Alert Tool (accessed from Field Notices), the Cisco Technical Services Newsletter, and Really Simple Syndication (RSS) Feeds.</p> <p>Access to most tools on the Cisco Support website requires a Cisco.com user ID and password.</p>	<a href="http://www.cisco.com/techsupport">http://www.cisco.com/techsupport</a>

## Feature Information for DHCP Server RADIUS Proxy

The following table provides release information about the feature or features described in this module. This table lists only the software release that introduced support for a given feature in a given software release train. Unless noted otherwise, subsequent releases of that software release train also support that feature.

Use Cisco Feature Navigator to find information about platform support and Cisco software image support. To access Cisco Feature Navigator, go to [www.cisco.com/go/cfn](http://www.cisco.com/go/cfn). An account on Cisco.com is not required.

Table 10: Feature Information for the Cisco IOS XE DHCP Relay Agent

Feature Name	Releases	Feature Configuration Information
DHCP Server RADIUS Proxy	Cisco IOS XE Release 2.4 Cisco IOS XE Release 3.9S	DHCP Server RADIUS Proxy enables a server to authorize remote clients and allocate addresses based on replies from the server.  In Cisco IOS XE 2.4, this feature was introduced on the Cisco ASR 1000 Series Aggregation Services Routers.  The following commands were modified by this feature: <b>authorization method (dhcp), authorization shared-password, authorization username (dhcp).</b>

## Glossary

**client** --A host trying to configure its interface (obtain an IP address) using DHCP or BOOTP protocols.

**DHCP** --Dynamic Host Configuration Protocol.

**giaddr** --Gateway IP address. The giaddr field of the DHCP message provides the DHCP server with information about the IP address subnet on which the client is to reside. It also provides the DHCP server with an IP address where the response messages are to be sent.

**MPLS** --Multiprotocol Label Switching. Emerging industry standard upon which tag switching is based.

**relay agent** --A router that forwards DHCP and BOOTP messages between a server and a client on different subnets.

**server** --DHCP or BOOTP server.

**VPN** --Virtual Private Network. Enables IP traffic to use tunneling to travel securely over a public TCP/IP network.

**VRF** --VPN routing and forwarding instance. A VRF consists of an IP routing table, a derived forwarding table, a set of interfaces that use the forwarding table, and a set of rules and routing protocols that determine what goes into the forwarding table. In general, a VRF includes the routing information that defines a customer VPN site that is attached to a PE router. Each VPN instantiated on the PE router has its own VRF.





## CHAPTER 7

# Configuring the Cisco IOS XE DHCP Client

Cisco IOS XE Dynamic Host Configuration Protocol (DHCP) client software provides the flexibility to include various configuration options for the DHCP client. A DHCP client is defined as an Internet host using DHCP to obtain configuration parameters such as an IP address. This module describes the concepts and tasks needed to configure the Cisco IOS XE DHCP client.

- [Finding Feature Information, on page 131](#)
- [Information About the DHCP Client, on page 131](#)
- [How to Configure the DHCP Client, on page 133](#)
- [Configuration Examples for the DHCP Client, on page 134](#)
- [Additional References, on page 136](#)
- [Technical Assistance, on page 137](#)
- [Feature Information for the Cisco IOS XE DHCP Client, on page 137](#)

## Finding Feature Information

Your software release may not support all the features documented in this module. For the latest caveats and feature information, see [Bug Search Tool](#) and the release notes for your platform and software release. To find information about the features documented in this module, and to see a list of the releases in which each feature is supported, see the feature information table.

Use Cisco Feature Navigator to find information about platform support and Cisco software image support. To access Cisco Feature Navigator, go to [www.cisco.com/go/cfn](http://www.cisco.com/go/cfn). An account on Cisco.com is not required.

## Information About the DHCP Client

### DHCP Client Operation

The Dynamic Host Configuration Protocol (DHCP) provides a framework for passing configuration information to hosts on a TCP/IP network. A DHCP client is an Internet host using DHCP to obtain configuration parameters such as an IP address. The figure below shows the basic steps that occur when a DHCP client requests an IP address from a DHCP server. The client, Host A, sends a DHCPDISCOVER broadcast message to locate a DHCP server. A DHCP server offers configuration parameters (such as an IP address, a MAC address, a domain name, and a lease for the IP address) to the client in a DHCPOFFER unicast message.

Figure 9: DHCP Request for an IP Address from a DHCP Server

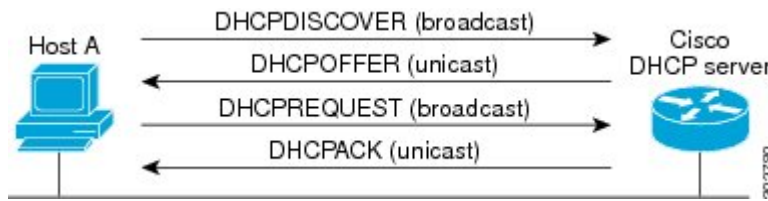

A DHCP client may receive offers from multiple DHCP servers and can accept any one of the offers; however, the client usually accepts the first offer it receives. The offer from the DHCP server is not a guarantee that the IP address will be allocated to the client; however, the server usually reserves the address until the client has had a chance to formally request the address.

The client returns a formal request for the offered IP address to the DHCP server in a DHCPREQUEST broadcast message. The DHCP server confirms that the IP address has been allocated to the client by returning a DHCPACK unicast message to the client.

## DHCP Client Overview

The configurable dynamic host configuration protocol client functionality allows a DHCP client to use a user-specified client identifier, class identifier, or suggested lease time when requesting an address from a DHCP server.

Configuration parameters and other control information are carried in tagged data items that are stored in the options field of the DHCP message. The DHCP client provides flexibility by allowing the following options to be configured for a DHCP client:

- Option 12—This option specifies the name of the client. The name may or may not be qualified with the local domain.
- Option 51—This option is used in a client request (DHCPDISCOVER or DHCPREQUEST) to allow the client to request a lease time for the IP address.
- Option 55—This option allows the DHCP client to request certain options from the DHCP server. The **ip dhcp client request** command allows the system administrator to turn off some of the requested options, thus removing them from the request list.
- Option 60—This option allows the user to configure the vendor class identifier string to use in the DHCP interaction.
- Option 61—This option is used by DHCP clients to specify their unique identifier. DHCP servers use this value to index their database of address bindings. This value is expected to be unique for all clients in an administrative domain.
- Option 77—This option is used by a DHCP clients to optionally identify the type or category of user or applications it represents. The information contained in this option represents the user class of which the client is a member. Based on this class, a DHCP server selects the appropriate address pool to assign an address to the client and the appropriate configuration parameters.
- Option 120—This option is used to specify a 32-bit (binary) IPv4 address to be used by the Session Initiation Protocol (SIP) client to locate a SIP server.

- Option 121—This option is used to configure classless static routes by specifying classless network destinations; that is, each routing table entry includes a subnet mask. Upto ten classless static routes are supported using option 121 on the DHCP client.



**Note** If a request includes both static routes and classless static routes, the client uses only the classless static routes. If the DHCP server returns both a classless static route option and a router option, the DHCP client ignores the router option.

- Option 124—This option is used by DHCP clients and servers to exchange vendor-class information.
- Option 125—This option is used by DHCP clients and servers to exchange vendor-specific information.

# How to Configure the DHCP Client

## Configuring the DHCP Client

Cisco devices running Cisco software include the Dynamic Host Configuration Protocol (DHCP) server and relay agent software, which are enabled by default. Your device can act as both the DHCP client and the DHCP server. Use the **ip address dhcp** command to obtain IP address information for the configured interface.

### SUMMARY STEPS

1. **enable**
2. **configure terminal**
3. **interface** *type number*
4. **ip address dhcp**
5. **end**
6. **debug dhcp detail**
7. **debug ip dhcp server packets**

### DETAILED STEPS

	Command or Action	Purpose
Step 1	<b>enable</b> <b>Example:</b> Device> enable	Enables privileged EXEC mode. <ul style="list-style-type: none"> <li>• Enter your password if prompted.</li> </ul>
Step 2	<b>configure terminal</b> <b>Example:</b> Device# configure terminal	Enters global configuration mode.

	Command or Action	Purpose
<b>Step 3</b>	<b>interface</b> <i>type number</i> <b>Example:</b>  Device(config)# interface GigabitEthernet 0/0/1	Configures an interface type and enters interface configuration mode.
<b>Step 4</b>	<b>ip address dhcp</b> <b>Example:</b>  Device(config-if)# ip address dhcp	Acquires an IP address on an interface from DHCP.
<b>Step 5</b>	<b>end</b> <b>Example:</b>  Device(config-if)# end	Returns to privileged EXEC mode.
<b>Step 6</b>	<b>debug dhcp detail</b> <b>Example:</b>  Device# debug dhcp detail	Displays the DHCP packets that were sent and received.
<b>Step 7</b>	<b>debug ip dhcp server packets</b> <b>Example:</b>  Device# debug ip dhcp server packets	Displays the server side of the DHCP interaction.

## Troubleshooting Tips

To verify the configuration, you can use the **debug dhcp detail** EXEC command to display the DHCP packets that were sent and received. To display the server side of the DHCP interaction, use the **debug ip dhcp server packets** command.

# Configuration Examples for the DHCP Client

## Configuring the DHCP Client Example

The figure below shows a simple network diagram of a DHCP client on an Ethernet LAN.

**Figure 10: Topology Showing DHCP Client with GigabitEthernet Interface**



On the DHCP server, the configuration is as follows:

```
ip dhcp pool 1
 network 10.1.1.0 255.255.255.0
 lease 1 6
```

On the DHCP client, the configuration is as follows on interface GigabitEthernet 0/0/0:

```
interface GigabitEthernet 0/0/0
 ip address dhcp
```

This configuration allows the DHCP client to acquire an IP address from the DHCP server through GigabitEthernet interface 0/0/0.

## Customizing the DHCP Client Configuration Example

The following example shows how to customize the DHCP client configuration with various options on GigabitEthernet interface 0/0/1:

```
interface GigabitEthernet 0/0/1
 ip dhcp client client-id ascii my-test1
 ip dhcp client class-id my-class-id
 ip dhcp client lease 0 1 0
 ip dhcp client hostname sanfran
 no ip dhcp client request tftp-server-address
 ip address dhcp
```

The following example shows DHCP Client configuration on GigabitEthernet 0/0/1 to generically request options:

```
!
interface GigabitEthernet 0/0/1
 ip dhcp client request option 4 5 7 8 9 10 11 17 18 40 41 42 66 68 69 70 71 72 73 74 75 76
 124 138 141 142 160
 no ip address
 shutdown
!
```

The following example shows how to configure DHCP Client options with parameters, IP address and string:

```
!
interface GigabitEthernet 0/0/1
 ip dhcp client option 1 ip 1.1.1.1
 ip dhcp client option 13 ascii test13
 ip dhcp client option 14 ascii test14
 ip dhcp client option 16 ip 1.1.1.16
 ip dhcp client option 46 ascii test46
 ip dhcp client option 47 ascii test47
 ip dhcp client option 50 ip 1.1.1.50
 ip dhcp client option 51 ascii test51
 ip dhcp client option 52 ascii test52
 ip dhcp client option 54 ascii test54
 ip dhcp client option 58 ascii test58
 ip dhcp client option 59 ascii test59
 ip dhcp client option 60 ascii test60
 ip dhcp client option 61 ascii test61
 ip dhcp client option 62 ascii test62
 ip dhcp client option 63 ip 1.1.1.63
 ip dhcp client option 64 ascii test64
```

```

ip dhcp client option 65 ip 1.1.1.65
ip dhcp client option 67 ascii test67
ip dhcp client option 90 ascii test90
ip dhcp client option 116 ascii test116
ip dhcp client option 118 ip 1.1.1.118
ip dhcp client option 220 ip 1.1.1.220
ip dhcp client option 221 ascii test221
ip address dhcp
shutdown
!
```

## Additional References

### Related Documents

Related Topic	Document Title
Cisco IOS commands	<a href="#">Cisco IOS Master Command List, All Releases</a>
DHCP commands: complete command syntax, command modes, command history, defaults, usage guidelines, and examples.	<a href="#">Cisco IOS IP Addressing Services Command Reference</a>
DHCP conceptual information	“DHCP Overview” module
DHCP server configuration	“Configuring the Cisco IOS XE DHCP Server” module
DHCP server on-demand address pools	“Configuring the DHCP Server On-Demand Address Pool Manager” module
DHCP relay agent configuration	“Configuring the Cisco IOS XE DHCP Relay Agent” module
DHCP advanced features	“Configuring DHCP Services for Accounting and Security” module

### RFCs

RFCs	Title
RFC 2131	Dynamic Host Configuration Protocol
RFC 2132	DHCP Options and BOOTP Vendor Extensions

**Technical Assistance**

Description	Link
The Cisco Support and Documentation website provides online resources to download documentation, software, and tools. Use these resources to install and configure the software and to troubleshoot and resolve technical issues with Cisco products and technologies. Access to most tools on the Cisco Support and Documentation website requires a Cisco.com user ID and password.	<a href="http://www.cisco.com/cisco/web/support/index.html">http://www.cisco.com/cisco/web/support/index.html</a>

## Technical Assistance

Description	Link
<p>The Cisco Support website provides extensive online resources, including documentation and tools for troubleshooting and resolving technical issues with Cisco products and technologies.</p> <p>To receive security and technical information about your products, you can subscribe to various services, such as the Product Alert Tool (accessed from Field Notices), the Cisco Technical Services Newsletter, and Really Simple Syndication (RSS) Feeds.</p> <p>Access to most tools on the Cisco Support website requires a Cisco.com user ID and password.</p>	<a href="http://www.cisco.com/techsupport">http://www.cisco.com/techsupport</a>

## Feature Information for the Cisco IOS XE DHCP Client

The following table provides release information about the feature or features described in this module. This table lists only the software release that introduced support for a given feature in a given software release train. Unless noted otherwise, subsequent releases of that software release train also support that feature.

Use Cisco Feature Navigator to find information about platform support and Cisco software image support. To access Cisco Feature Navigator, go to [www.cisco.com/go/cfn](http://www.cisco.com/go/cfn). An account on Cisco.com is not required.

*Table 11: Feature Information for the Cisco IOS XE DHCP Client*

Feature Name	Releases	Feature Configuration Information
DHCP Client	Cisco IOS XE Release 2.3 Cisco IOS XE Release 3.9S	A DHCP client is defined as an Internet host using DHCP to obtain configuration parameters such as an IP address.  The following command was introduced by this feature: <b>ip address dhcp</b>

Feature Name	Releases	Feature Configuration Information
Configurable DHCP Client	Cisco IOS XE Release 2.3 Cisco IOS XE Release 3.9S	<p>The configurable DHCP client functionality allows a DHCP client to use a user-specified client identifier, class identifier, or suggested lease time when requesting an address from a DHCP server.</p> <p>The following commands were introduced by this feature:  <b>ip dhcp client class-id, ip dhcp client client-id, ip dhcp client hostname, ip dhcp client lease, ip dhcp client request</b></p>
DHCPv4 Client Options	Cisco IOS XE Fuji 16.9.1	The DHCP Client supports configuration of all 1-254 options.





## CHAPTER 8

# Configuring DHCP Services for Accounting and Security

---

Cisco IOS XE software supports several capabilities that enhance DHCP security, reliability, and accounting in Public Wireless LANs (PWLANS). This functionality can also be used in other network implementations. This module describes the concepts and tasks needed to configure DHCP services for accounting and security.

- [Finding Feature Information, on page 139](#)
- [Prerequisites for Configuring DHCP Services for Accounting and Security, on page 139](#)
- [Information About DHCP Services for Accounting and Security, on page 140](#)
- [How to Configure DHCP Services for Accounting and Security, on page 141](#)
- [Configuration Examples for DHCP Services for Accounting and Security, on page 149](#)
- [Additional References, on page 151](#)
- [Technical Assistance, on page 152](#)
- [Feature Information for DHCP Services for Accounting and Security, on page 153](#)

## Finding Feature Information

Your software release may not support all the features documented in this module. For the latest caveats and feature information, see [Bug Search Tool](#) and the release notes for your platform and software release. To find information about the features documented in this module, and to see a list of the releases in which each feature is supported, see the feature information table.

Use Cisco Feature Navigator to find information about platform support and Cisco software image support. To access Cisco Feature Navigator, go to [www.cisco.com/go/cfn](http://www.cisco.com/go/cfn). An account on Cisco.com is not required.

## Prerequisites for Configuring DHCP Services for Accounting and Security

Before you configure DHCP services for accounting and security, you should understand the concepts documented in the “DHCP Overview” module.

# Information About DHCP Services for Accounting and Security

## DHCP Operation in Public Wireless LANs

The configuration of DHCP in a public wireless LAN (PWLAN) simplifies the configuration of wireless clients and reduces the overhead necessary to maintain the network. DHCP clients are leased IP addresses by the DHCP server and then authenticated by the Service Selection Gateway (SSG), which allows the clients to access network services. The DHCP server and client exchange DHCP messages for IP address assignments. When a DHCP server assigns an IP address to a client, a DHCP binding is created. The IP address is leased to the client until the client explicitly releases the IP address and disconnects from the network. If the client disconnects without releasing the address, the server terminates the lease after the lease time is over. In either case, the DHCP server removes the binding and the IP address is returned to the pool.

## Security Vulnerabilities in Public Wireless LANs

As more people start using PWLANs, security becomes an important concern. Most implementations of PWLANs rely on DHCP for users to obtain an IP address while in a hot spot (such as a coffee shop, airport terminal, hotel, and so on) and use this IP address provided by the DHCP server throughout their session.

IP spoofing is a common technique used by hackers to spoof IP addresses. For example, customer A obtains an IP address from DHCP and has already been authenticated to use the PWLAN, but a hacker spoofs the IP address of customer A and uses this IP address to send and receive traffic. Customer A will still be billed for the service even though he or she is not using the service.

Address Resolution Protocol (ARP) table entries are dynamic by design. Request and reply ARP packets are sent and received by all the networking devices in a network. In a DHCP network, the DHCP server stores the leased IP address to the MAC address or the client-identifier of the client in the DHCP binding. But as ARP entries are learned dynamically, an unauthorized client can spoof the IP address given by the DHCP server and start using that IP address. The MAC address of this unauthorized client will replace the MAC address of the authorized client in the ARP table allowing the unauthorized client to freely use the spoofed IP address.

## DHCP Services for Security and Accounting Overview

DHCP security and accounting features have been designed and implemented to address the security concerns in PWLANs but also can be used in other network implementations.

DHCP accounting provides authentication, authorization, and accounting (AAA) and Remote Authentication Dial-In User Service (RADIUS) support for DHCP. The AAA and RADIUS support improves security by sending secure START and STOP accounting messages. The configuration of DHCP accounting adds a layer of security that allows DHCP lease assignment and termination to be triggered for the appropriate RADIUS START and STOP accounting records so that the session state is properly maintained by upstream devices, such as an SSG. This additional security can help to prevent unauthorized clients or hackers from gaining illegal entry to the network by spoofing authorized DHCP leases.

The DHCP Secured IP Address Assignment feature prevents IP spoofing by synchronizing the database of the DHCP server with the ARP table to avoid address hijacking. This secure ARP functionality adds an entry to the ARP table for a client when an address is allocated that can be deleted by the DHCP server only when a binding expires.

The third feature is ARP autologoff, which adds finer control for probing when authorized users log out. The **arp probe interval** command specifies when to start a probe (the timeout), how frequent a peer is probed (the interval), and the maximum number of retries (the count).

## DHCP Lease Limits

You can control the number of subscribers globally or on a per-interface basis by configuring a DHCP lease limit. This functionality allows an Internet service provider (ISP) to limit the number of leases available to clients per household or connection.

# How to Configure DHCP Services for Accounting and Security

## Configuring AAA and RADIUS for DHCP Accounting

Perform this task to configure AAA and RADIUS for DHCP accounting.

RADIUS provides the accounting capability for the transmission of secure START and STOP messages. AAA and RADIUS are enabled prior to the configuration of DHCP accounting but can also be enabled to secure an insecure DHCP network. The configuration steps in this section are required for configuring DHCP accounting in a new or existing network.

DHCP accounting introduces the attributes shown in the table below. These attributes are processed directly by the RADIUS server when DHCP accounting is enabled. These attributes can be monitored in the output of the debug radius command. The output will show the status of the DHCP leases and specific configuration details about the client. The accounting keyword can be used with the debug radius command to filter the output and display only DHCP accounting messages.

**Table 12: RADIUS Accounting Attributes**

Attribute	Description
Calling-Station-ID	The output from this attribute displays the MAC address of the client.
Framed-IP-Address	The output from this attribute displays the IP address that is leased to the client.
Acct-Terminate-Cause	The output from this attribute displays the message “session-timeout” if a client does not explicitly disconnect.

### SUMMARY STEPS

1. **enable**
2. **configure terminal**
3. **aaa new-model**
4. **aaa group server radius *group-name***
5. **server *ip-address* **auth-port** *port-number* **acct-port** *port-number***
6. **exit**
7. **aaa accounting {system | network | exec | connection | commands *level*} {default | *list-name*} {start-stop | stop-only | none} [broadcast] group *group-name***
8. **aaa session-id {common | unique}**

9. **ip radius source-interface** *type number* [*vrf vrf-name*]
10. **radius-server host** {*hostname | ip-address*} [**auth-port** *port-number*] [**acct-port** *port-number*]
11. **radius-server attribute 31 send nas-port-detail mac-only**
12. **radius-server retransmit number-of-retries**

## DETAILED STEPS

	Command or Action	Purpose
Step 1	<b>enable</b> <b>Example:</b> Device> enable	Enables privileged EXEC mode. <ul style="list-style-type: none"> <li>• Enter your password if prompted.</li> </ul>
Step 2	<b>configure terminal</b> <b>Example:</b> Device# configure terminal	Enters global configuration mode.
Step 3	<b>aaa new-model</b> <b>Example:</b> Device(config)# aaa new-model	Enables the AAA access control model. <ul style="list-style-type: none"> <li>• DHCP accounting functions only in the access control model.</li> </ul> <p><b>Note</b> TACACS and extended TACACS commands are not available after this command is configured and are not supported by DHCP accounting.</p>
Step 4	<b>aaa group server radius</b> <i>group-name</i> <b>Example:</b> Device(config)# aaa group server radius RGROUP-1	Creates a server group for AAA or TACACS+ services and enters server group configuration mode. <ul style="list-style-type: none"> <li>• The server group is created in this step so that accounting services can be applied.</li> </ul>
Step 5	<b>server</b> <i>ip-address</i> <b>auth-port</b> <i>port-number</i> <b>acct-port</b> <i>port-number</i> <b>Example:</b> Device(config-sg-radius)# server 10.0.0.1 auth-port 1645 acct-port 1646	Specifies the servers that are members of the server group that was created in Step 4. <ul style="list-style-type: none"> <li>• You must open port numbers for authorization and accounting. 1645 is the default port number for authorization, and 1646 is the default port number for accounting. The range of port numbers that can be specified is from 0 to 65535.</li> <li>• The values entered for the auth-port port-number and acct-port port-number keywords and arguments must match the port numbers that will be configured in Step 10.</li> </ul>
Step 6	<b>exit</b> <b>Example:</b>	Exits server group configuration mode and enters global configuration mode.

	Command or Action	Purpose
	Device(config-sg-radius)# exit	
<b>Step 7</b>	<p><b>aaa accounting</b> {system   network   exec   connection   commands <i>level</i>} {default   list-name} {start-stop   stop-only   none} [broadcast] group group-name</p> <p><b>Example:</b></p> <pre>Device(config)# aaa accounting network RADIUS-GROUP1 start-stop group RGROUP-1</pre>	<p>Configures RADIUS accounting for the specified server group.</p> <ul style="list-style-type: none"> <li>The RADIUS accounting server is specified in the first list-name argument (RADIUS-GROUP1), and the target server group is specified in the second group-name argument (RGROUP-1).</li> <li>This command enables start and stop accounting for DHCP accounting. The start-stop keyword enables the transmission of both START and STOP accounting messages. The stop-only keyword will enable the generation and verification of STOP accounting messages only.</li> </ul>
<b>Step 8</b>	<p><b>aaa session-id</b> {common   unique}</p> <p><b>Example:</b></p> <pre>Device(config)# aaa session-id common</pre>	Specifies whether the same session ID will be used for each AAA accounting service type within a call or whether a different session ID will be assigned to each accounting service type.
<b>Step 9</b>	<p><b>ip radius source-interface</b> <i>type number</i> [<i>vrf vrf-name</i>]</p> <p><b>Example:</b></p> <pre>Device(config)# ip radius source-interface GigabitEthernet 0/0/0</pre>	Forces RADIUS to use the IP address of the specified interface for all outgoing RADIUS packets.
<b>Step 10</b>	<p><b>radius-server host</b> {hostname   ip-address} [<b>auth-port</b> <i>port-number</i>] [<b>acct-port</b> <i>port-number</i>]</p> <p><b>Example:</b></p> <pre>Device(config)# radius-server host 10.1.1.1 auth-port 1645 acct-port 1646</pre>	<p>Specifies the radius server host.</p> <ul style="list-style-type: none"> <li>The values entered for the auth-port port-number and acct-port port-number keywords and arguments must match the port numbers that were configured in Step 5.</li> </ul>
<b>Step 11</b>	<p><b>radius-server attribute 31 send nas-port-detail mac-only</b></p> <p><b>Example:</b></p> <pre>Device(config)# radius-server attribute 31 send nas-port-detail mac-only</pre>	(Optional) Allows the MAC address of the client to be included in the Calling-Station-ID attribute. The Calling-Station-ID attribute is processed by the RADIUS server when DHCP accounting is enabled.
<b>Step 12</b>	<p><b>radius-server retransmit number-of-retries</b></p> <p><b>Example:</b></p> <pre>Device(config)# radius-server retransmit 3</pre>	Specifies the number of times that Cisco IOS XE software will look for RADIUS server hosts.

## Troubleshooting Tips

To monitor and troubleshoot the configuration of RADIUS accounting, use the following command:

Command	Purpose
<b>debug radius accounting</b>  Device# debug radius accounting	The <b>debug radius</b> command is used to display RADIUS events on the console of the device. These events provide information about RADIUS processes. DHCP accounting information can be filtered with the accounting keyword. START and STOP accounting message information will also be displayed.

## Configuring DHCP Accounting

Perform this task to configure DHCP accounting.

DHCP accounting is enabled with the **accounting** command. This command configures DHCP to operate with AAA and RADIUS to enable secure START and STOP accounting messages. This configuration adds a layer of security that allows DHCP lease assignment and termination to be triggered for the appropriate RADIUS START and STOP accounting records so that the session state is properly maintained by upstream devices, such as the SSG.

DHCP accounting is configured on a per-client or per-lease basis. Separate DHCP accounting processes can be configured on a per-pool basis.

### Before you begin

You must configure an SSG for client authentication. AAA and RADIUS must be enabled before DHCP accounting will operate.



**Note** The following restrictions apply to DHCP accounting:

- DHCP accounting can be configured only for DHCP network pools in which bindings are created automatically and destroyed upon lease termination or when the client sends a DHCPRELEASE message.
- DHCP bindings are destroyed when the **clear ip dhcp binding** or **no service dhcp** commands are entered, which also triggers an accounting STOP message. You should exercise caution when entering these commands if a pool is configured with DHCP accounting, as these commands will clear active leases.

### SUMMARY STEPS

1. **enable**
2. **configure terminal**
3. **ip dhcp pool** *pool-name*
4. **accounting** *method-list-name*

### DETAILED STEPS

	Command or Action	Purpose
Step 1	<b>enable</b>  <b>Example:</b>	Enables privileged EXEC mode. <ul style="list-style-type: none"> <li>• Enter your password if prompted.</li> </ul>

	Command or Action	Purpose
	Device> enable	
<b>Step 2</b>	<b>configure terminal</b> <b>Example:</b> Device# configure terminal	Enters global configuration mode.
<b>Step 3</b>	<b>ip dhcp pool <i>pool-name</i></b> <b>Example:</b> Device(config)# ip dhcp pool WIRELESS-POOL	Configures a DHCP address pool and enters DHCP pool configuration mode.
<b>Step 4</b>	<b>accounting <i>method-list-name</i></b> <b>Example:</b> Device(dhcp-config)# accounting RADIUS-GROUP1	Enables DHCP accounting if the specified server group is configured to run RADIUS accounting. <ul style="list-style-type: none"> <li>The example configures DHCP accounting START and STOP messages to be sent if RADIUS-GROUP1 is configured as a start-stop group. STOP messages will only be sent if RADIUS-GROUP1 is configured as a stop-only group. See Step 7 in the "Configuring AAA and RADIUS for DHCP Accounting" configuration task table for more details.</li> </ul>

## Verifying DHCP Accounting

Perform this task to verify the DHCP accounting configuration.

The debug radius, debug ip dhcp server events, debug aaa accounting, debug aaa id commands do not need to be issued together or in the same session as there are differences in the information that is provided. These commands, however, can be used to display DHCP accounting start and stop events, AAA accounting messages, and information about AAA and DHCP hosts and clients. See the "RADIUS Accounting Attributes" section of this module for a list of AAA attributes that have been introduced by DHCP accounting. The show running-config | begin dhcp command can be used to display the local DHCP configuration including the configuration of DHCP accounting.

### SUMMARY STEPS

1. enable
2. debug radius accounting
3. debug ip dhcp server events
4. debug aaa accounting
5. debug aaa id
6. show running-config | begin dhcp

## DETAILED STEPS

	Command or Action	Purpose
<b>Step 1</b>	<b>enable</b> <b>Example:</b> Device> enable	Enables higher privilege levels, such as privileged EXEC mode. <ul style="list-style-type: none"> <li>• Enter your password if prompted.</li> </ul>
<b>Step 2</b>	<b>debug radius accounting</b> <b>Example:</b> Device# debug radius accounting	Displays RADIUS events on the console of the device. <ul style="list-style-type: none"> <li>• These events provide information about RADIUS processes. DHCP accounting information can be filtered with the accounting keyword. START and STOP accounting messages will be displayed in the output.</li> </ul>
<b>Step 3</b>	<b>debug ip dhcp server events</b> <b>Example:</b> Device# debug ip dhcp server events	Displays DHCP IP address assignments, DHCP lease expirations, and DHCP database changes.
<b>Step 4</b>	<b>debug aaa accounting</b> <b>Example:</b> Device# debug aaa accounting	Displays AAA accounting events. <ul style="list-style-type: none"> <li>• START and STOP accounting messages will be displayed in the output.</li> </ul>
<b>Step 5</b>	<b>debug aaa id</b> <b>Example:</b> Device# debug aaa id	Displays AAA events as they relate to unique AAA session IDs.
<b>Step 6</b>	<b>show running-config   begin dhcp</b> <b>Example:</b> Device# show running-config   begin dhcp	The <b>show running-config</b> command is used to display the local configuration of the device. The sample output is filtered with the <b>begin</b> keyword to start displaying output at the DHCP section of the running configuration.

## Securing ARP Table Entries to DHCP Leases

Perform this task to secure ARP table entries to DHCP leases in the DHCP database.

When the **update arp** command is used, ARP table entries and their corresponding DHCP leases are secured automatically for all new leases and DHCP bindings. However, existing active leases are not secured. These leases are still insecure until they are renewed. When the lease is renewed, it is treated as a new lease and will be secured automatically. If this command is disabled on the DHCP server, all existing secured ARP table entries will automatically change to dynamic ARP entries.

## SUMMARY STEPS

1. enable



2. `configure terminal`
3. `ip dhcp pool pool-name`
4. `update arp`
5. `renew deny unknown`

## DETAILED STEPS

	Command or Action	Purpose
Step 1	<b>enable</b> <b>Example:</b> <pre>Device&gt; enable</pre>	Enables privileged EXEC mode. <ul style="list-style-type: none"> <li>• Enter your password if prompted.</li> </ul>
Step 2	<b>configure terminal</b> <b>Example:</b> <pre>Device# configure terminal</pre>	Enters global configuration mode.
Step 3	<b>ip dhcp pool pool-name</b> <b>Example:</b> <pre>Device(config)# ip dhcp pool WIRELESS-POOL</pre>	Configures a DHCP address pool and enters DHCP pool configuration mode.
Step 4	<b>update arp</b> <b>Example:</b> <pre>Device(dhcp-config)# update arp</pre>	Secures insecure ARP table entries to the corresponding DHCP leases. <ul style="list-style-type: none"> <li>• Existing active DHCP leases will not be secured until they are renewed. Using the <b>no update arp</b> command will change secured ARP table entries back to dynamic ARP table entries.</li> </ul>
Step 5	<b>renew deny unknown</b> <b>Example:</b> <pre>Device(dhcp-config)# renew deny unknown</pre>	(Optional) Configures the renewal policy for unknown clients. <ul style="list-style-type: none"> <li>• See the <a href="#">Troubleshooting Tips, on page 143</a> section for information about when to use this command.</li> </ul>

## Troubleshooting Tips

Use the `debug ip dhcp server class` command to display the class matching results.

## Configuring a DHCP Lease Limit to Control the Number of Subscribers on an Interface

Perform this task to limit the number of DHCP leases allowed on an interface.

This feature allows an ISP to limit the number of leases available to clients per household or connection on an interface.

If this feature is enabled on the Cisco IOS XE DHCP server directly connected to clients through unnumbered interfaces, the server allocates addresses and increments the number of leases per subinterface. If a new client tries to obtain an IP address, the server will not offer an IP address if the number of leases on the subinterface has already reached the configured lease limit.



**Note** This feature is not supported on numbered interfaces. The lease limit can be applied only to ATM with RBE unnumbered interfaces or serial unnumbered interfaces.

## SUMMARY STEPS

1. **enable**
2. **configure terminal**
3. **ip dhcp limit lease log**
4. **interface** *type number*
5. **ip dhcp limit lease** *lease-limit*
6. **end**
7. **show ip dhcp limit lease** [*type number*]
8. **show ip dhcp server statistics** [*type number*]

## DETAILED STEPS

	Command or Action	Purpose
<b>Step 1</b>	<b>enable</b> <b>Example:</b>  Device> enable	Enables privileged EXEC mode.  • Enter your password if prompted.
<b>Step 2</b>	<b>configure terminal</b> <b>Example:</b>  Device# configure terminal	Enters global configuration mode.
<b>Step 3</b>	<b>ip dhcp limit lease log</b> <b>Example:</b>  Device(config)# ip dhcp limit lease log	(Optional) Enables DHCP lease violation logging when a DHCP lease limit threshold is exceeded.  • If this command is configured, any lease limit violations will display in the output of the <b>show ip dhcp limit lease</b> command.
<b>Step 4</b>	<b>interface</b> <i>type number</i> <b>Example:</b>  Device(config)# interface Serial0/0/0	Enters interface configuration mode.
<b>Step 5</b>	<b>ip dhcp limit lease</b> <i>lease-limit</i> <b>Example:</b>	Limits the number of leases offered to DHCP clients per interface.

	Command or Action	Purpose
	Device(config-if)# ip dhcp limit lease 6	<ul style="list-style-type: none"> <li>The interface configuration will override any global setting specified by the <b>ip dhcp limit lease per interface global configuration</b> command.</li> </ul>
<b>Step 6</b>	<b>end</b> <b>Example:</b> Device(config-if)# end	Exits the configuration mode and returns to privileged EXEC mode.
<b>Step 7</b>	<b>show ip dhcp limit lease</b> [ <i>type number</i> ] <b>Example:</b> Device# show ip dhcp limit lease Serial10/0/0	(Optional) Displays the number of times the lease limit threshold has been violated. <ul style="list-style-type: none"> <li>You can use the <b>clear ip dhcp limit lease</b> privileged EXEC command to manually clear the stored lease violation entries.</li> </ul>
<b>Step 8</b>	<b>show ip dhcp server statistics</b> [ <i>type number</i> ] <b>Example:</b> Device# show ip dhcp server statistics Serial 0/0/0	(Optional) Displays DHCP server statistics.

## Troubleshooting Tips

You can use the **debug ip dhcp server packet** and **debug ip server events** commands to troubleshoot the DHCP lease limit.

# Configuration Examples for DHCP Services for Accounting and Security

## Example: Configuring AAA and RADIUS for DHCP Accounting

The following example shows how to configure AAA and RADIUS for DHCP accounting:

```

aaa new-model
aaa group server radius RGROUP-1
 server 10.1.1.1 auth-port 1645 acct-port 1646
 exit
aaa accounting network RADIUS-GROUP1 start-stop group RGROUP-1
aaa session-id common
ip radius source-interface GigabitEthernet0/0/0
radius-server host 10.1.1.1 auth-port 1645 acct-port 1646
radius-server attribute 31 send nas-port-detail mac-only
radius-server retransmit 3
exit

```

## Example: Configuring DHCP Accounting

DHCP accounting is configured on a per-client or per-lease basis. Separate DHCP accounting processes can be configured on a per-pool basis. The following example shows how to configure DHCP accounting START and STOP messages to be sent if RADIUS-GROUP1 is configured as a start-stop group.

```
ip dhcp pool WIRELESS-POOL
  accounting RADIUS-GROUP1
exit
```

## Example: Verifying DHCP Accounting

DHCP accounting is enabled after both RADIUS and AAA for DHCP are configured. DHCP START and STOP accounting generation information can be monitored with the **debug radius accounting** and **debug ip dhcp server events** commands. See the "RADIUS Accounting Attributes" section of this module for a list of AAA attributes that have been introduced by DHCP accounting.

The following is sample output from the **debug radius accounting** command. The output shows the DHCP lease session ID, the MAC address, and the IP address of the client interface.

```
00:00:53: RADIUS: Pick NAS IP for uid=2 tableid=0 cfg_addr=10.0.18.3 best_addr=0.0.0.0
00:00:53: RADIUS(00000002): sending
00:00:53: RADIUS(00000002): Send to unknown id 21645/1 10.1.1.1 :1646, Accounting-Request,
  len 76
00:00:53: RADIUS: authenticator C6 FE EA B2 1F 9A 85 A2 - 9A 5B 09 B5 36 B5 B9 27
00:00:53: RADIUS: Acct-Session-Id [44] 10 "00000002"
00:00:53: RADIUS: Framed-IP-Address [8] 6 10.0.0.10
00:00:53: RADIUS: Calling-Station-Id [31] 16 "00000c59df76"
00:00:53: RADIUS: Acct-Status-Type [40] 6 Start [1]
00:00:53: RADIUS: Service-Type [6] 6 Framed [2]
00:00:53: RADIUS: NAS-IP-Address [4] 6 10.0.18.3
00:00:53: RADIUS: Acct-Delay-Time [41] 6 0
```

The following is sample output from the **debug ip dhcp server events** command. The output was generated on a DHCP server and shows an exchange of DHCP messages between the client and server to negotiate a DHCP lease. The acknowledgment that confirms to the DHCP server that the client has accepted the assigned IP address triggers the accounting START message. It is shown in the last line of the following output:

```
00:45:50:DHCPD:DHCPDISCOVER received from client
0063.6973.636f.2d30.3030.312e.3432.6339.2e65.6337.352d.4574.31 on
interface GigabitEthernet0/0/0.
00:45:52:DHCPD:assigned IP address 10.10.10.16 to client
0063.6973.636f.2d30.3030.312e.3432.6339.2e65.6337.352d.4574.31.
00:45:52:DHCPD:Sending DHCPPOFFER to client
0063.6973.636f.2d30.3030.312e.3432.6339.2e65.6337.352d.4574.31(10.10.10.16)
00:45:52:DHCPD:broadcasting BOOTREPLY to client 0001.42c9.ec75.
00:45:52:DHCPD:DHCPREQUEST received from client
0063.6973.636f.2d30.3030.312e.3432.6339.2e65.6337.352d.4574.31.
00:45:52:DHCPD:Sending DHCPACK to client
0063.6973.636f.2d30.3030.312e.3432.6339.2e65.6337.352d.4574.31
(10.10.10.16) .
00:45:52:DHCPD:broadcasting BOOTREPLY to client 0001.42c9.ec75.
00:45:52:DHCPD:triggered Acct Start for 0001.42c9.ec75 (10.10.10.16) .
```

The following is sample output from the **debug ip dhcp server events** command. The output was generated on a DHCP server and shows the receipt of an explicit release message from the DHCP client. The DHCP

server triggers an accounting STOP message and then returns the IP address to the DHCP pool. Information about the accounting STOP message is shown in the third line of the following output:

```
00:46:26:DHCPD:DHCPRELEASE message received from client
0063.6973.636f.2d30.3030.312e.3432.6339.2e65.6337.352d.4574.31 (10.10.10.16)
00:46:26:DHCPD:triggered Acct Stop for (10.10.10.16).
00:46:26:DHCPD:returned 10.10.10.16 to address pool WIRELESS-POOL.
```

## Example: Configuring a DHCP Lease Limit

In the following example, 5 DHCP clients are allowed to receive IP addresses. If a sixth client tries to obtain an IP address, the DHCPDISCOVER messages will not be forwarded to the DHCP server and a trap will be sent to the SNMP manager.

```
ip dhcp limit lease log
!
ip dhcp pool pool1
 network 10.1.1.0 255.255.255.0
!
interface loopback0
 ip address 10.1.1.1 255.255.255.0
!
interface serial 0/0.2 point-to-point
 ip dhcp limit lease 5
 ip unnumbered loopback0
 exit
snmp-server enable traps dhcp interface
```

## Additional References

The following sections provide references related to configuring DHCP services for accounting and security.

### Related Documents

Related Topic	Document Title
ARP commands: complete command syntax, command modes, defaults, usage guidelines, and examples	<i>Cisco IOS IP Addressing Services Command Reference</i>
DHCP commands: complete command syntax, command modes, defaults, usage guidelines, and examples	<i>Cisco IOS IP Addressing Services Command Reference</i>
DHCP conceptual information	“DHCP Overview” module
DHCP server configuration	“Configuring the Cisco IOS XE DHCP Server” module
DHCP ODAP configuration	“Configuring the DHCP Server On-Demand Address Pool Manager” module
DHCP client configuration	“Configuring the Cisco IOS XE DHCP Client” module

Related Topic	Document Title
DHCP relay agent configuration	“Configuring the Cisco IOS XE DHCP Relay Agent” module
AAA and RADIUS configuration tasks	<i>Cisco IOS Security Configuration Guide</i>
AAA and RADIUS commands: complete command syntax, command mode, defaults, usage guidelines, and examples	<i>Cisco IOS Security Command Reference</i>

### MIBs

MIBs	MIBs Link
No new or modified MIBs are supported by this feature, and support for existing MIBs has not been modified by this feature.	To locate and download MIBs for selected platforms, Cisco IOS XE software releases, and feature sets, use Cisco MIB Locator found at the following URL:  <a href="http://www.cisco.com/go/mibs">http://www.cisco.com/go/mibs</a>

### Technical Assistance

Description	Link
The Cisco Support and Documentation website provides online resources to download documentation, software, and tools. Use these resources to install and configure the software and to troubleshoot and resolve technical issues with Cisco products and technologies. Access to most tools on the Cisco Support and Documentation website requires a Cisco.com user ID and password.	<a href="http://www.cisco.com/cisco/web/support/index.html">http://www.cisco.com/cisco/web/support/index.html</a>

## Technical Assistance

Description	Link
<p>The Cisco Support website provides extensive online resources, including documentation and tools for troubleshooting and resolving technical issues with Cisco products and technologies.</p> <p>To receive security and technical information about your products, you can subscribe to various services, such as the Product Alert Tool (accessed from Field Notices), the Cisco Technical Services Newsletter, and Really Simple Syndication (RSS) Feeds.</p> <p>Access to most tools on the Cisco Support website requires a Cisco.com user ID and password.</p>	<a href="http://www.cisco.com/techsupport">http://www.cisco.com/techsupport</a>

# Feature Information for DHCP Services for Accounting and Security

The following table provides release information about the feature or features described in this module. This table lists only the software release that introduced support for a given feature in a given software release train. Unless noted otherwise, subsequent releases of that software release train also support that feature.

Use Cisco Feature Navigator to find information about platform support and Cisco software image support. To access Cisco Feature Navigator, go to [www.cisco.com/go/cfn](http://www.cisco.com/go/cfn). An account on Cisco.com is not required.

**Table 13: Feature Information for DHCP Services for Accounting and Security**

Feature Name	Releases	Feature Configuration Information
DHCP Per Interface Lease Limit and Statistics	Cisco IOS XE Release 2.1	This feature limits the number of DHCP leases offered to DHCP clients on an interface. DHCP server statistics reporting was enhanced to display interface-level statistics.  The following commands were introduced or modified by this feature: <b>ip dhcp limit lease</b> , <b>ip dhcp limit lease log</b> , <b>clear ip dhcp limit lease</b> , <b>show ip dhcp limit lease</b> , and <b>show ip dhcp server statistics</b> .
DHCP Accounting	Cisco IOS XE Release 2.1 Cisco IOS XE Release 3.9S	DHCP accounting introduces AAA and RADIUS support for DHCP configuration.  The following command was introduced by this feature: <b>accounting</b> .
DHCP Secured IP Address Assignment	Cisco IOS XE Release 2.3 Cisco IOS XE Release 3.9S	DHCP secure IP address assignment provides the capability to secure ARP table entries to DHCP leases in the DHCP database. This feature secures and synchronizes the MAC address of the client to the DHCP binding, preventing unauthorized clients or hackers from spoofing the DHCP server and taking over a DHCP lease of an authorized client.  The following command was introduced by this feature: <b>update arp</b> .  The following command was modified by this feature: <b>show ip dhcp server statistics</b> .
ARP Auto-logoff	Cisco IOS XE Release 3.9S	The ARP Auto-logoff feature enhances DHCP authorized ARP by providing finer control and probing of authorized clients to detect a logoff.  The following command was introduced by this feature: <b>arp probe interval</b> .







## CHAPTER 9

# ISSU and SSO--DHCP High Availability Features

Cisco IOS XE Release 2.1 and 2.3 introduce the following series of Dynamic Host Configuration Protocol (DHCP) High Availability features:

- ISSU--DHCP Server
- SSO--DHCP Server
- ISSU--DHCP Relay on Unnumbered Interface
- SSO--DHCP Relay on Unnumbered Interface
- ISSU--DHCP Proxy Client
- SSO--DHCP Proxy Client
- ISSU--DHCP ODAP Client and Server
- SSO--DHCP ODAP Client and Server

These features are enabled by default when the redundancy mode of operation is set to Stateful Switchover (SSO).

- [Finding Feature Information, on page 155](#)
- [Prerequisites for DHCP High Availability, on page 156](#)
- [Restrictions for DHCP High Availability, on page 156](#)
- [Information About DHCP High Availability, on page 156](#)
- [How to Configure DHCP High Availability, on page 160](#)
- [Configuration Examples for DHCP High Availability, on page 160](#)
- [Additional References, on page 160](#)
- [Feature Information for DHCP High Availability Features, on page 162](#)
- [Glossary, on page 162](#)

## Finding Feature Information

Your software release may not support all the features documented in this module. For the latest caveats and feature information, see [Bug Search Tool](#) and the release notes for your platform and software release. To find information about the features documented in this module, and to see a list of the releases in which each feature is supported, see the feature information table.

Use Cisco Feature Navigator to find information about platform support and Cisco software image support. To access Cisco Feature Navigator, go to [www.cisco.com/go/cfn](http://www.cisco.com/go/cfn). An account on Cisco.com is not required.

## Prerequisites for DHCP High Availability

- The Cisco IOS XE In-Service Software Upgrade (ISSU) process must be configured and working properly. See the “Cisco IOS XE In-Service Software Upgrade Process” feature module for more information.
- Stateful Switchover (SSO) must be configured and working properly. See the “Stateful Switchover” feature module for more information.
- Nonstop Forwarding (NSF) must be configured and working properly. See the “Cisco Nonstop Forwarding” feature module for more information.

## Restrictions for DHCP High Availability

The DHCP high availability features do not support DHCP accounting or DHCP authorized Address Resolution Protocol (ARP).

## Information About DHCP High Availability

### ISSU

The ISSU process allows Cisco IOS XE software to be updated or otherwise modified while packet forwarding continues. In most networks, planned software upgrades are a significant cause of downtime. ISSU allows Cisco IOS XE software to be modified while packet forwarding continues, which increases network availability and reduces downtime caused by planned software upgrades.

### SSO

SSO refers to the implementation of Cisco IOS XE software that allows applications and features to maintain a defined state between an active and standby Route Processor (RP).

In specific Cisco networking devices that support dual RPs, SSO takes advantage of RP redundancy to increase network availability. The SSO feature takes advantage of RP redundancy by establishing one of the RPs as the active RP while the other RP is designated as the standby RP, and then synchronizing critical state information between them. Following an initial synchronization between the two processors, SSO dynamically maintains RP state information between them.

A switchover from the active to the standby processor occurs when the active RP fails, is removed from the networking device, or is manually taken down for maintenance.

## ISSU and SSO--DHCP Server

The DHCP server that is ISSU and SSO aware is able to detect when a router is failing over to the standby RP and preserve the DHCP lease across a switchover event.

Each DHCP binding is synchronized and re-created from the active RP to the standby RP upon lease commit. The figure below illustrates this process. The lease extension and release are also synchronized to the standby RP.

**Figure 11: DHCP Server Maintaining States Between the Active and Standby Route Processor**

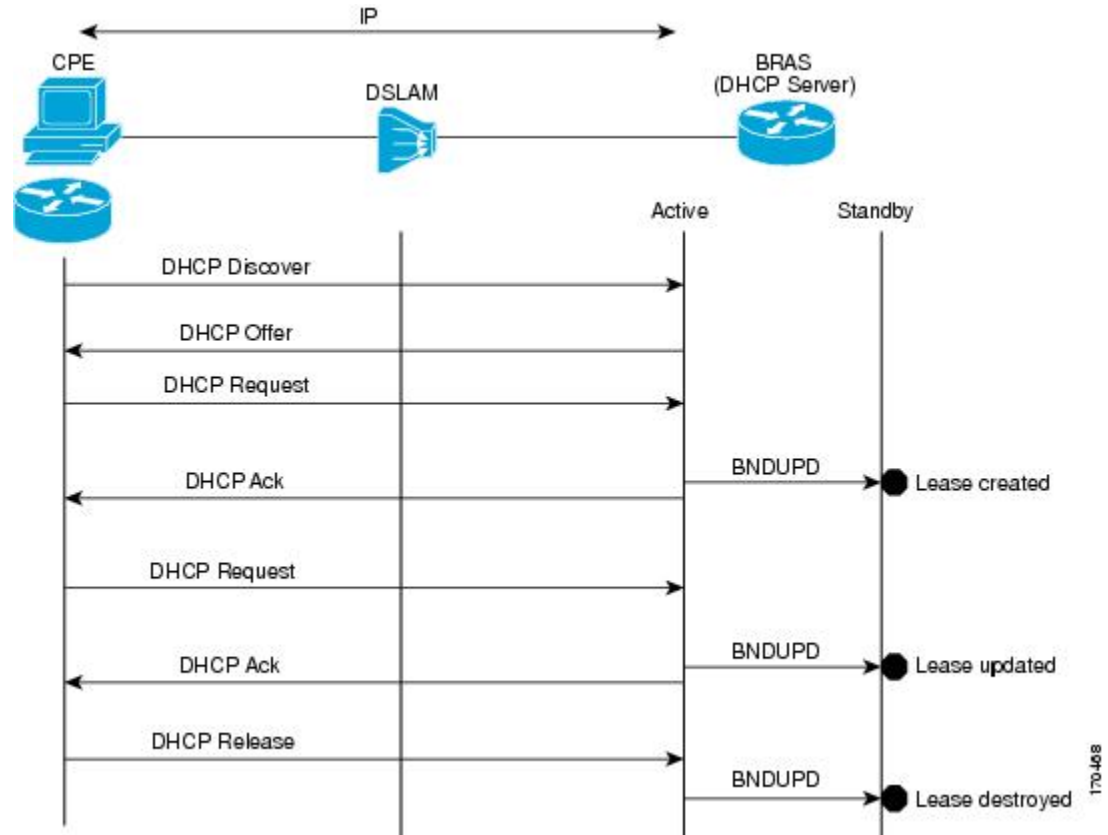

## ISSU and SSO--DHCP Relay on Unnumbered Interface

The DHCP relay agent supports the use of unnumbered interfaces. For DHCP clients connected through the unnumbered interfaces, the DHCP relay agent automatically adds a static host route once the DHCP client obtains an address, specifying the unnumbered interface as the outbound interface. The route is automatically removed once the lease time expires or when the client releases the address.

The **ip helper-address** interface configuration command must be configured on the unnumbered interface to enable the Cisco IOS XE DHCP relay agent on unnumbered interfaces. See the “Configuring the Cisco IOS XE DHCP Relay Agent” configuration module for more information.

The ISSU and SSO DHCP relay on unnumbered interface functionality adds high availability support for host routes to clients connected through unnumbered interfaces. The DHCP relay agent can now detect when a router is failing over to the standby RP and keep the states related to unnumbered interfaces. The figure below illustrates the process.

Figure 12: DHCP Maintaining States with an IP Unnumbered Interface

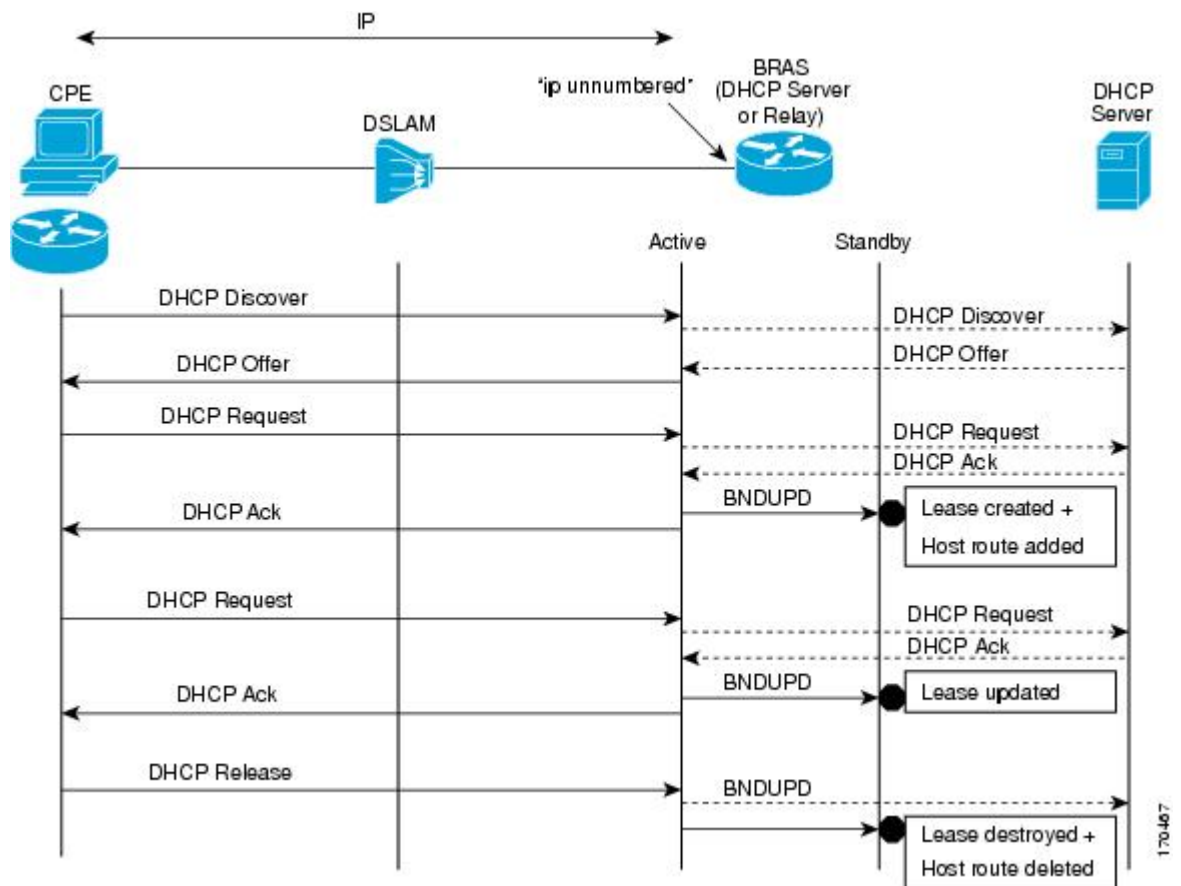

## ISSU and SSO--DHCP Proxy Client

The DHCP proxy client enables the router to obtain a lease for configuration parameters from a DHCP server for a remote Point-to-Point Protocol (PPP) client. The DHCP proxy client that is ISSU and SSO aware is able to request a lease from the DHCP server and the state of the lease is synchronized between the active and standby RP. The figure below illustrates the process.

Figure 13: DHCP Proxy Client Lease Synchronization

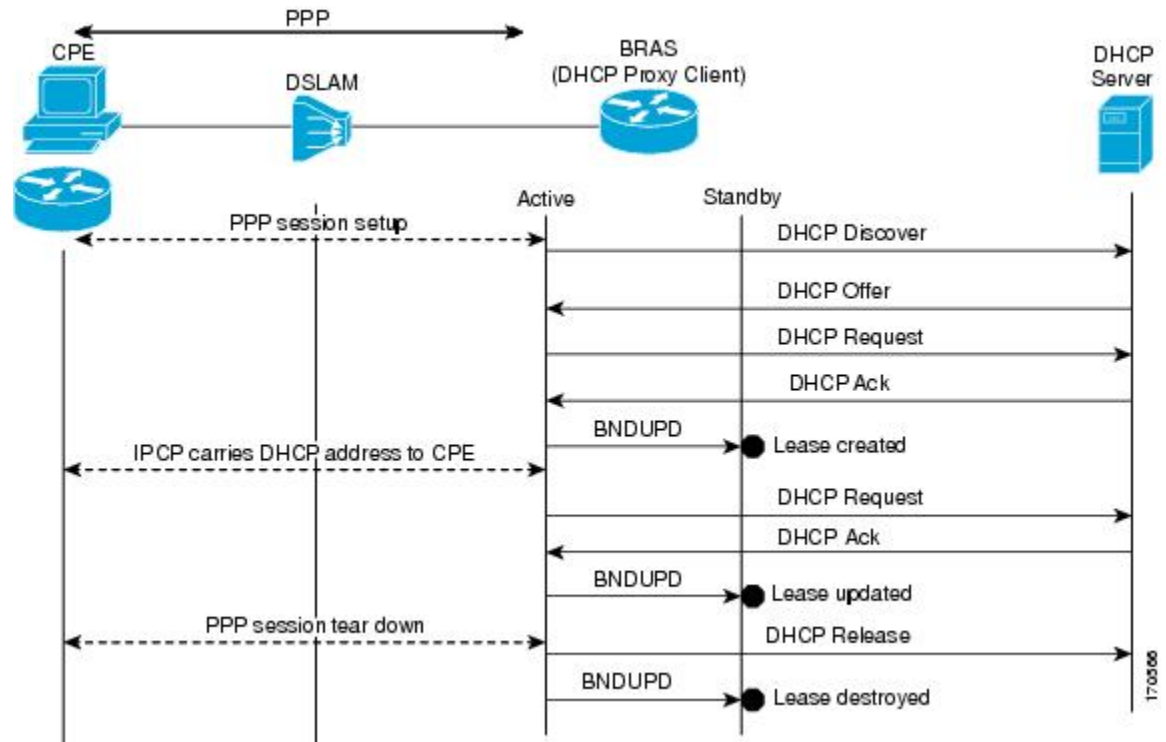

## ISSU and SSO--DHCP ODAP Client and Server

The DHCP on-demand address pool (ODAP) client that is ISSU and SSO aware can request a lease for a subnet from the DHCP ODAP server. After the DHCP ODAP server allocates the subnet to the client, the state of the lease is synchronized between the active and standby RP through binding updates. Following a switchover event, the DHCP ODAP client can continue to allocate IP addresses from the same subnets and also continue to renew the subnets from the DHCP ODAP server. The figure below illustrates the process.

Figure 14: ODAP Subnet Lease Synchronization

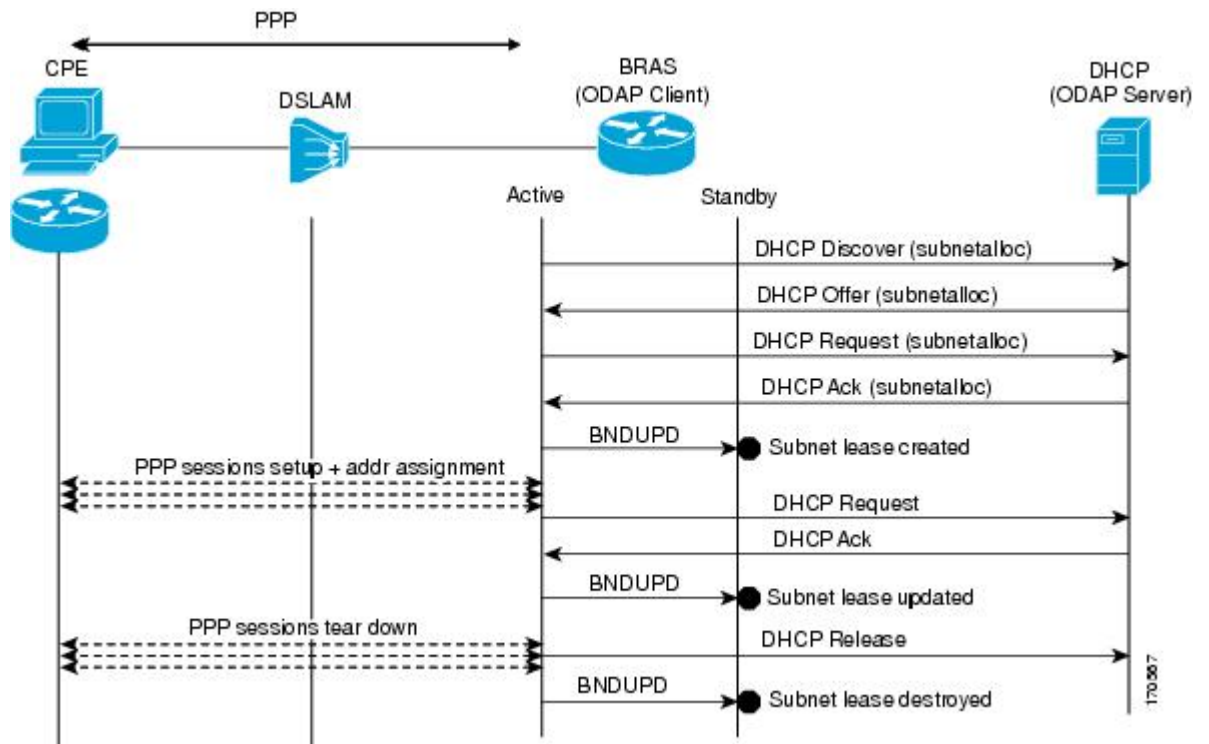

## How to Configure DHCP High Availability

There are no configuration tasks. The DHCP high availability features are enabled by default when the redundancy mode of operation is set to SSO.

## Configuration Examples for DHCP High Availability

There are no configuration examples for DHCP high availability features.

## Additional References

The following sections provide references related to DHCP high availability features.

### Related Documents

Related Topic	Document Title
DHCP commands: complete command syntax, command modes, command history, defaults, usage guidelines, and examples	<i>Cisco IOS IP Addressing Services Command Reference</i>

Related Topic	Document Title
DHCP conceptual and configuration information	<i>Cisco IOS XE IP Addressing Services Configuration Guide</i>
In-Service Software Upgrade process conceptual and configuration information	"Cisco IOS XE In Service Software Upgrade Process" module
Nonstop Forwarding conceptual and configuration information	"Cisco Nonstop Forwarding" module
Stateful switchover conceptual and configuration information	"Stateful Switchover" module

### Standards

Standard	Title
No new or modified standards are supported by this feature.	--

### MIBs

MIB	MIBs Link
No new or modified MIBs are supported by this feature.	To locate and download MIBs for selected platforms, Cisco IOS XE software releases, and feature sets, use Cisco MIB Locator found at the following URL:  <a href="http://www.cisco.com/go/mibs">http://www.cisco.com/go/mibs</a>

### RFCs

RFC	Title
No new or modified RFCs are supported by this feature.	--

### Technical Assistance

Description	Link
<p>The Cisco Support website provides extensive online resources, including documentation and tools for troubleshooting and resolving technical issues with Cisco products and technologies.</p> <p>To receive security and technical information about your products, you can subscribe to various services, such as the Product Alert Tool (accessed from Field Notices), the Cisco Technical Services Newsletter, and Really Simple Syndication (RSS) Feeds.</p> <p>Access to most tools on the Cisco Support website requires a Cisco.com user ID and password.</p>	<a href="http://www.cisco.com/techsupport">http://www.cisco.com/techsupport</a>

## Feature Information for DHCP High Availability Features

The following table provides release information about the feature or features described in this module. This table lists only the software release that introduced support for a given feature in a given software release train. Unless noted otherwise, subsequent releases of that software release train also support that feature.

Use Cisco Feature Navigator to find information about platform support and Cisco software image support. To access Cisco Feature Navigator, go to [www.cisco.com/go/cfn](http://www.cisco.com/go/cfn). An account on Cisco.com is not required.

**Table 14: Feature Information for DHCP High Availability Features**

Feature Name	Releases	Feature Information
ISSU--DHCP Server	Cisco IOS XE Release 2.1	The DHCP server has been enhanced to support ISSU.
SSO--DHCP Server	Cisco IOS XE Release 2.1	The DHCP server has been enhanced to support SSO.
ISSU--DHCP Relay on Unnumbered Interface	Cisco IOS XE Release 2.3	The DHCP relay on unnumbered interface has been enhanced to support ISSU.
SSO--DHCP Relay on Unnumbered Interface	Cisco IOS XE Release 2.1	The DHCP relay on unnumbered interface has been enhanced to support SSO.
ISSU--DHCP Proxy Client	Cisco IOS XE Release 2.3	The DHCP proxy client has been enhanced to support ISSU.
SSO--DHCP Proxy Client	Cisco IOS XE Release 2.3	The DHCP proxy client has been enhanced to support SSO.
ISSU--DHCP ODAP Client and Server	Cisco IOS XE Release 2.3	The DHCP ODAP client and server have been enhanced to support ISSU.
SSO--DHCP ODAP Client and Server	Cisco IOS XE Release 2.3	The DHCP ODAP client and server have been enhanced to support SSO.

## Glossary

**CPE** --customer premises equipment. Terminating equipment, such as terminals, telephones, and modems, supplied by the service provider, installed at customer sites, and connected to the network.

**DSLAM** --digital subscriber line access multiplexer. A device that connects many digital subscriber lines to a network by multiplexing the DSL traffic onto one or more network trunk lines.

**ISSU** --In Service Software Upgrade. ISSU is a process that allows Cisco IOS software to be updated or otherwise modified while packet forwarding continues.

**ODAP** --On-Demand Address Pool. ODAPs enable pools of IP addresses to be dynamically increased or reduced in size depending on the address utilization level. Once configured, the ODAP is populated with one or more subnets leased from a source server and is ready to serve address requests from DHCP clients or from PPP sessions.



**RP** --Route Processor. A generic term for the centralized control unit in a chassis.

**SSO** --Stateful Switchover. SSO refers to the implementation of Cisco IOS software that allows applications and features to maintain a defined state between an active and standby RP. When a switching occurs, forwarding and sessions are maintained. SSO makes an RP failure undetectable to the network.





## CHAPTER 10

# DHCPv6 Relay and Server - MPLS VPN Support

- [Finding Feature Information, on page 165](#)
- [Information About DHCPv6 Relay and Server - MPLS VPN Support, on page 165](#)
- [How to Configure DHCPv6 Relay and Server - MPLS VPN Support, on page 166](#)
- [Configuration Examples for DHCPv6 Server - MPLS VPN Support, on page 168](#)
- [Additional References, on page 169](#)
- [Feature Information for DHCPv6 Relay and Server - MPLS VPN Support, on page 170](#)

## Finding Feature Information

Your software release may not support all the features documented in this module. For the latest caveats and feature information, see [Bug Search Tool](#) and the release notes for your platform and software release. To find information about the features documented in this module, and to see a list of the releases in which each feature is supported, see the feature information table.

Use Cisco Feature Navigator to find information about platform support and Cisco software image support. To access Cisco Feature Navigator, go to [www.cisco.com/go/cfn](http://www.cisco.com/go/cfn). An account on Cisco.com is not required.

## Information About DHCPv6 Relay and Server - MPLS VPN Support

### DHCPv6 Server and Relay—MPLS VPN Support

To facilitate managed central services in a Multiprotocol Label Switching (MPLS)-based network, DHCPv6 must be made MPLS-aware so that a single resource can be used to serve multiple VPNs instead of dedicating a resource to a single VPN.

The DHCPv6 server implementation of MPLS VPN allows a per-pool configuration so that DHCPv6 pools can be associated with a VPN routing and forwarding (VRF) instance. The DHCPv6 server differentiates clients from various VRFs and assigns an IPv6 prefix accordingly from the respective VRF pools. Meanwhile, the DHCPv6 bindings store the clients' VRF information.

The DHCPv6 relay implementation allows the configuration of the destination VRF instance to which the relay messages will be forwarded. The relay adds the client's VPN information while forwarding the client's

DHCPv6 requests toward the server, and the relay agent then processes the client's VPN information in reply packets from the server.

The relay agent adds IPv6 static routes for delegated prefixes in corresponding clients' VRF, and the relay agent's high availability (HA) functionality synchronizes the VRF information while synchronizing static routes created by the relay process.

The DHCPv6 relay and server VRF-aware features are disabled by default.

# How to Configure DHCPv6 Relay and Server - MPLS VPN Support

## Configuring a VRF-Aware Relay and Server for MPLS VPN Support

### Configuring a VRF-Aware Relay



**Note** You do not have to configure this feature on specified interfaces. If you want the feature to be enabled globally only on a device, perform steps 1, 2, and 3

#### SUMMARY STEPS

1. **enable**
2. **configure terminal**
3. **ipv6 dhcp-relay option vpn**
4. **interface** *type number*
5. **ipv6 dhcp relay option vpn**
6. **ipv6 dhcp relay destination** *ipv6-address* [*interface-type interface-number* | **vrf** *vrf-name* | **global**]
7. **end**

#### DETAILED STEPS

	Command or Action	Purpose
<b>Step 1</b>	<b>enable</b> <b>Example:</b> Device> enable	Enables privileged EXEC mode. <ul style="list-style-type: none"> <li>• Enter your password if prompted.</li> </ul>
<b>Step 2</b>	<b>configure terminal</b> <b>Example:</b> Device# configure terminal	Enters global configuration mode.
<b>Step 3</b>	<b>ipv6 dhcp-relay option vpn</b> <b>Example:</b>	Enables the DHCP for IPv6 relay VRF-aware feature globally.

	Command or Action	Purpose
	Device(config)# ipv6 dhcp-relay option vpn	
<b>Step 4</b>	<b>interface</b> <i>type number</i> <b>Example:</b> Device(config)# interface gigabitethernet 0/0/0	Specifies an interface type and number, and enters interface configuration mode.
<b>Step 5</b>	<b>ipv6 dhcp relay option vpn</b> <b>Example:</b> Device(config-if)# ipv6 dhcp relay option vpn	Enables the DHCP for IPv6 relay VRF-aware feature on the specified interface. Enabling this command supersedes the configuration that is enabled by using the <b>ipv6 dhcp-relay option vpn</b> command.
<b>Step 6</b>	<b>ipv6 dhcp relay destination</b> <i>ipv6-address</i> [ <i>interface-type interface-number</i>   <b>vrf</b> <i>vrf-name</i>   <b>global</b> ] <b>Example:</b> Device(config-if)# ipv6 dhcp relay destination FE80::250:A2FF:FEBF:A056 ethernet 0/0	Specifies a destination address to which client messages are forwarded.
<b>Step 7</b>	<b>end</b> <b>Example:</b> Device(config-if)# end	Returns to privileged EXEC mode.

## Configuring a VRF-Aware Server

### SUMMARY STEPS

1. enable
2. configure terminal
3. interface *type number*
4. ipv6 dhcp server vrf enable
5. end

### DETAILED STEPS

	Command or Action	Purpose
<b>Step 1</b>	<b>enable</b> <b>Example:</b> Device> enable	Enables privileged EXEC mode. <ul style="list-style-type: none"><li>• Enter your password if prompted.</li></ul>
<b>Step 2</b>	<b>configure terminal</b> <b>Example:</b> Device# configure terminal	Enters global configuration mode.

	Command or Action	Purpose
<b>Step 3</b>	<b>interface</b> <i>type number</i> <b>Example:</b> Device(config)# interface gigabitethernet 0/0/0	Specifies an interface type and number, and enters interface configuration mode.
<b>Step 4</b>	<b>ipv6 dhcp server vrf enable</b> <b>Example:</b> Device(config-if)# ipv6 dhcp server vrf enable	Enables the DHCPv6 server VRF-aware feature on an interface.
<b>Step 5</b>	<b>end</b> <b>Example:</b> Device(config-if)# end	Returns to privileged EXEC mode.

## Configuration Examples for DHCPv6 Server - MPLS VPN Support

### Example: Configuring a VRF-Aware Relay

```
Router# show ipv6 dhcp relay binding

Relay Bindings associated with default vrf:
Prefix: 2001:DB8:0:1::/64 (GigabitEthernet0/0/0)
  DUID: 00030001AABBCC006500
  IAID: 196609
  lifetime: 2592000
  expiration: 12:34:28 IST Oct 14 2010
Summary:
  Total number of Relay bindings = 1
  Total number of Relay bindings added by Bulk lease = 0
```

### Example: Configuring a VRF-Aware Server

```
Router# show ipv6 dhcp binding

Client: FE80::A8BB:CCFF:FE00:6400
  DUID: 00030001AABBCC006400
  VRF : global
  Interface : GigabitEthernet0/0/0
  IA PD: IA ID 0x00030001, T1 302400, T2 483840
  Prefix: 2001::1/64
         preferred lifetime 604800, valid lifetime 2592000
         expires at Oct 15 2010 03:18 PM (2591143 seconds)

Router# show ipv6 route status

IPv6 Routing Table - default - 4 entries
```

```

Codes: C - Connected, L - Local, S - Static, U - Per-user Static route
       B - BGP, R - RIP, I1 - ISIS L1, I2 - ISIS L2
       IA - ISIS interarea, IS - ISIS summary, D - EIGRP, EX - EIGRP external
       ND - Neighbor Discovery
       O - OSPF Intra, OI - OSPF Inter, OE1 - OSPF ext 1, OE2 - OSPF ext 2
       ON1 - OSPF NSSA ext 1, ON2 - OSPF NSSA ext 2
S    2001::/64 [1/0]
    via FE80::A8BB:CFFF:FE00:6400, GigabitEthernet0/0/0

```

## Additional References

### Related Documents

Related Topic	Document Title
IPv6 addressing and connectivity	<i>IPv6 Configuration Guide</i>
Cisco IOS commands	<i>Cisco IOS Master Commands List, All Releases</i>
IPv6 commands	<i>Cisco IOS IPv6 Command Reference</i>
Cisco IOS IPv6 features	<i>Cisco IOS IPv6 Feature Mapping</i>

### Standards and RFCs

Standard/RFC	Title
RFCs for IPv6	<i>IPv6 RFCs</i>

### MIBs

MIB	MIBs Link
	To locate and download MIBs for selected platforms, Cisco IOS releases, and feature sets, use Cisco MIB Locator found at the following URL: <a href="http://www.cisco.com/go/mibs">http://www.cisco.com/go/mibs</a>

**Technical Assistance**

Description	Link
The Cisco Support and Documentation website provides online resources to download documentation, software, and tools. Use these resources to install and configure the software and to troubleshoot and resolve technical issues with Cisco products and technologies. Access to most tools on the Cisco Support and Documentation website requires a Cisco.com user ID and password.	<a href="http://www.cisco.com/cisco/web/support/index.html">http://www.cisco.com/cisco/web/support/index.html</a>

## Feature Information for DHCPv6 Relay and Server - MPLS VPN Support

The following table provides release information about the feature or features described in this module. This table lists only the software release that introduced support for a given feature in a given software release train. Unless noted otherwise, subsequent releases of that software release train also support that feature.

Use Cisco Feature Navigator to find information about platform support and Cisco software image support. To access Cisco Feature Navigator, go to [www.cisco.com/go/cfn](http://www.cisco.com/go/cfn). An account on Cisco.com is not required.

*Table 15: Feature Information for DHCPv6 Relay and Server - MPLS VPN Support*

Feature Name	Releases	Feature Information
DHCPv6 Relay - MPLS VPN Support	Cisco IOS XE Release 3.3S	<p>The DHCPv6 relay implementation allows the configuration of the destination VRF instance to which the relay messages will be forwarded.</p> <p>The following commands were introduced or modified: <b>ipv6 dhcp relay destination</b>, <b>ipv6 dhcp relay option vpn</b>, <b>ipv6 dhcp server vrf enable</b>, <b>show ipv6 dhcp relay binding</b>.</p>



Feature Name	Releases	Feature Information
DHCPv6 Server - MPLS VPN Support	Cisco IOS XE Release 3.3S	<p>The DHCPv6 server implementation of MPLS VPN support allows a per-pool configuration so DHCPv6 pools can be associated with a VRF instance.</p> <p>The following commands were introduced or modified: <b>ipv6 dhcp relay destination, ipv6 dhcp relay option vpn, ipv6 dhcp server vrf enable, show ipv6 dhcp relay binding.</b></p>





## CHAPTER 11

# IPv6 Access Services: DHCPv6 Relay Agent

A Dynamic Host Configuration Protocol for IPv6 (DHCPv6) relay agent, which may reside on the client's link, is used to relay messages between the client and the server.

- [Finding Feature Information, on page 173](#)
- [Information About IPv6 Access Services: DHCPv6 Relay Agent, on page 173](#)
- [How to Configure IPv6 Access Services: DHCPv6 Relay Agent, on page 176](#)
- [Configuration Examples for IPv6 Access Services: DHCPv6 Relay Agent, on page 177](#)
- [Additional References, on page 178](#)
- [Feature Information for IPv6 Access Services: DHCPv6 Relay Agent, on page 178](#)

## Finding Feature Information

Your software release may not support all the features documented in this module. For the latest caveats and feature information, see [Bug Search Tool](#) and the release notes for your platform and software release. To find information about the features documented in this module, and to see a list of the releases in which each feature is supported, see the feature information table.

Use Cisco Feature Navigator to find information about platform support and Cisco software image support. To access Cisco Feature Navigator, go to [www.cisco.com/go/cfn](http://www.cisco.com/go/cfn). An account on Cisco.com is not required.

## Information About IPv6 Access Services: DHCPv6 Relay Agent

### DHCPv6 Relay Agent

A DHCPv6 relay agent, which may reside on the client's link, is used to relay messages between the client and the server. The DHCPv6 relay agent operation is transparent to the client. A DHCPv6 client locates a DHCPv6 server using a reserved, link-scoped multicast address. For direct communication between the DHCPv6 client and the DHCPv6 server, both of them must be attached to the same link. However, in some situations where ease of management, economy, or scalability is a concern, it is desirable to allow a DHCPv6 client to send a message to a DHCPv6 server that is not connected to the same link. IPv6 enable is required for IPv6 DHCP relay, although IPv6 address is configured.

### DHCPv6 Relay Agent Notification for Prefix Delegation

The DHCPv6 relay agent notification for prefix delegation allows the device working as a DHCPv6 relay agent to find prefix delegation options by reviewing the contents of a DHCPv6 RELAY-REPLY packet that is relayed by the relay agent to the client. When a prefix delegation option is found by the relay agent, the relay agent extracts the information about the prefix that is being delegated and inserts an IPv6 static route matching the prefix delegation information onto the relay agent. Future packets destined to that prefix via relay will be forwarded based on the information contained in the prefix delegation. The IPv6 static route is then left in the routing table until the prefix delegation lease time expires or the relay agent receives a release packet from the client releasing the prefix delegation.

No user configuration is required for this feature. Static route management is done automatically by the relay agent.

IPv6 routes are added when the relay agent relays a RELAY-REPLY packet, and IPv6 routes are deleted when the prefix delegation lease time expires or the relay agent receives a release message. An IPv6 static route in the routing table of the relay agent can be updated when the prefix delegation lease time is extended.

The DHCP—DHCPv6 Relay Agent Notification for Prefix Delegation feature leaves a static IPv6 route on the routing table of the relay agent. The registered IPv6 address allows unicast reverse packet forwarding (uRPF) to work by allowing the device doing the reverse lookup to confirm that the IPv6 address on the relay agent is not malformed or spoofed. The static route that remains in the routing table of the relay agent can be redistributed to other routing protocols to advertise the subnets to other nodes. Static routes will be removed when a DHCP\_DECLINE message is sent by the client.

### DHCPv6 Relay Options: Remote-ID for Gigabit Ethernet and Fast Ethernet Interfaces

The DHCPv6 Ethernet Remote ID Option feature adds the remote identification (remote-ID) option to relayed (RELAY-FORWARD) DHCPv6 packets.

The remote-ID option provides information to the DHCPv6 server, which includes port information, the system's DUID, and the VLAN ID. This information can be used to uniquely identify both the relay and the port on the relay through which the client packet arrived. The DHCPv6 server uses this information to select parameters specific to a particular user, host, or subscriber modem.

The addition of the remote-ID option to the RELAY-FORWARD packet occurs automatically and no user configuration is necessary.

The DHCPv6 server does not need to echo the remote-ID option in the RELAY-REPLY packet. The Internet Assigned Numbers Authority (IANA) has assigned the DHCPv6 option code 37 for the relay agent remote-ID option.

If the remote-ID option is included in the RELAY-REPLY packet, the option is removed from the packet before it is relayed to the client.

### DHCPv6 Relay Options: Reload Persistent Interface ID

The DHCPv6 Relay—Reload Persistent Interface ID Option feature makes the interface ID option persistent. The interface ID is used by relay agents to decide which interface should be used to forward a RELAY-REPLY packet. A persistent interface-ID option will not change if the device acting as a relay agent goes offline during a reload or a power outage. When the device acting as a relay agent returns online, it is possible that changes to the internal interface index of the relay agent may have occurred in certain scenarios (such as, when the relay agent reboots and the number of interfaces in the interface index changes, or when the relay agents boot up and has more virtual interfaces than it did before the reboot). This feature prevents such scenarios from causing any problems.

This feature changes the DHCPv6 interface-ID option to be expressed as the short form of the interface name. The interface name as the DHCPv6 interface ID helps avoid potential problems that could arise due to physical or logical interfaces changing on the relay agent after a reload.

### DHCPv6 Relay Chaining

DHCPv6 messages can be relayed through multiple relay agents. This configuration is called *relay chaining*. A relay chaining configuration can be supported only when each relay agent adds information to DHCPv6 messages before relaying them. The information helps in relaying the DHCPv6 reply back to the DHCPv6 client through the same path.

The delegated IPv6 prefix must be routable in order to be useful. The actual DHCPv6 Prefix Delegation (PD) client may not be permitted to inject routes into the delegating network. In service provider (SP) networks, for example, an edge device typically acts as a DHCPv6 relay agent, and this edge device often has the responsibility to maintain routes within the SP network for clients' PD bindings. In the event that DHCPv6 requests and responses are relayed through a chain of DHCPv6 relays, there may be a need to introduce appropriate routes (particularly with DHCPv6 PD) in the Forwarding Information Base (FIB) so that routing is handled transparently.

## DHCPv6 Relay Agent Notification for Prefix Delegation

The DHCPv6 relay agent notification for prefix delegation allows the device working as a DHCPv6 relay agent to find prefix delegation options by reviewing the contents of a DHCPv6 RELAY-REPLY packet that is relayed by the relay agent to the client. When a prefix delegation option is found by the relay agent, the relay agent extracts the information about the prefix that is being delegated and inserts an IPv6 static route matching the prefix delegation information onto the relay agent. Future packets destined to that prefix via relay will be forwarded based on the information contained in the prefix delegation. The IPv6 static route is then left in the routing table until the prefix delegation lease time expires or the relay agent receives a release packet from the client releasing the prefix delegation.

No user configuration is required for this feature. Static route management is done automatically by the relay agent.

IPv6 routes are added when the relay agent relays a RELAY-REPLY packet, and IPv6 routes are deleted when the prefix delegation lease time expires or the relay agent receives a release message. An IPv6 static route in the routing table of the relay agent can be updated when the prefix delegation lease time is extended.

The DHCP—DHCPv6 Relay Agent Notification for Prefix Delegation feature leaves a static IPv6 route on the routing table of the relay agent. The registered IPv6 address allows unicast reverse packet forwarding (uRPF) to work by allowing the device doing the reverse lookup to confirm that the IPv6 address on the relay agent is not malformed or spoofed. The static route that remains in the routing table of the relay agent can be redistributed to other routing protocols to advertise the subnets to other nodes. Static routes will be removed when a DHCP\_DECLINE message is sent by the client.

## DHCPv6 Relay Options: Remote ID for Ethernet Interfaces

This feature adds the remote identification (remote-ID) option to relayed (RELAY-FORWARD) DHCPv6 packets.

The remote-ID option provides information to the DHCPv6 server, including port information, the system's DUID, and the VLAN ID. Collectively, this information can be used to uniquely identify both the relay and the port on the relay through which the client's packet arrived. The DHCPv6 server uses this information to select parameters specific to a particular user, host, or subscriber modem. This feature works only for Ethernet interfaces at this time.

This feature introduces no user configuration. Because the addition of the remote-ID option to the RELAY-FORWARD packet occurs automatically, no user configuration is necessary.

The DHCPv6 server does not need to echo the remote-ID option in the RELAY-REPLY packet. Internet Assigned Numbers Authority (IANA) has assigned the DHCPv6 option code 37 for the relay agent remote-ID option.

If the remote-ID option is included in the RELAY-REPLY packet, the option is stripped out of the packet before the packet is relayed to the client.

## DHCPv6 Relay Options: Reload Persistent Interface ID Option

This feature makes the interface-ID option, which is used by relay agents to decide which interface should be used when forwarding a RELAY-REPLY packet, persistent. A persistent interface-ID option will not change if the router acting as a relay agent goes offline (such as during a reload or a power outage). When the router acting as a relay agent returns online, it is possible that changes to the internal interface index of the relay agent may have occurred in certain scenarios (such as cases where the relay agent reboots and has a change in the number of interfaces in the interface index, or the relay agents boots up and has more virtual interfaces than it did before the reboot). This feature prevents this scenario from causing any problems.

This feature changes the DHCPv6 interface-ID option to be expressed as simply the short form of the interface name. This syntax helps avoid potential problems that could arise due to physical or logical interfaces changing on the relay agent after a reload.

## DHCPv6 Relay Chaining

This feature makes the interface-ID option, which is used by relay agents to decide which interface should be used when forwarding a RELAY-REPLY packet, persistent. A persistent interface-ID option will not change if the router acting as a relay agent goes offline (such as during a reload or a power outage). When the router acting as a relay agent returns online, it is possible that changes to the internal interface index of the relay agent may have occurred in certain scenarios (such as cases where the relay agent reboots and has a change in the number of interfaces in the interface index, or the relay agents boots up and has more virtual interfaces than it did before the reboot). This feature prevents this scenario from causing any problems.

This feature changes the DHCPv6 interface-ID option to be expressed as simply the short form of the interface name. This syntax helps avoid potential problems that could arise due to physical or logical interfaces changing on the relay agent after a reload.

# How to Configure IPv6 Access Services: DHCPv6 Relay Agent

## Configuring the DHCPv6 Relay Agent

### SUMMARY STEPS

1. **enable**
2. **configure terminal**
3. **interface** *type number*
4. **ipv6 enable**
5. **ipv6 dhcp relay destination** *ipv6-address* [*interface-type interface-number*]
6. **end**

## DETAILED STEPS

	Command or Action	Purpose
Step 1	<b>enable</b> <b>Example:</b> Device> enable	Enables privileged EXEC mode. <ul style="list-style-type: none"> <li>• Enter your password if prompted.</li> </ul>
Step 2	<b>configure terminal</b> <b>Example:</b> Device# configure terminal	Enters global configuration mode.
Step 3	<b>interface</b> <i>type number</i> <b>Example:</b> Device(config)# interface gigabitethernet 4/2/0	Specifies an interface type and number, and enters interface configuration mode.
Step 4	<b>ipv6 enable</b> <b>Example:</b> Device(config-if)# ipv6 enable	Enables IPv6 processing on an interface.
Step 5	<b>ipv6 dhcp relay destination</b> <i>ipv6-address [interface-type interface-number]</i> <b>Example:</b> Device(config-if) ipv6 dhcp relay destination FE80::250:A2FF:FEBF:A056 gigabitethernet 4/3/0	Specifies a destination address to which client packets are forwarded and enables the DHCPv6 relay service on the interface.
Step 6	<b>end</b> <b>Example:</b> Device(config-if)# end	Returns to privileged EXEC mode.

## Configuration Examples for IPv6 Access Services: DHCPv6 Relay Agent

### Example: Configuring the DHCPv6 Relay Agent

```

Device# show ipv6 dhcp interface

Ethernet1/0 is in relay mode
  Relay destinations:
    3FFB:C00:C18:6:A8BB:CCFF:FE03:2701
Serial3/0 is in relay mode

```

```
Relay destinations:
 3FFB:C00:C18:6:A8BB:CCFF:FE03:2600
 FE80::A8BB:CCFF:FE03:2801 on Serial3/0
 FF05::1:3
```

## Additional References

### Related Documents

Related Topic	Document Title
Cisco IOS commands	<a href="#">Cisco IOS Master Commands List, All Releases</a>
IPv6 commands	<a href="#">Cisco IOS IPv6 Command Reference</a>
IPv6 addressing and connectivity	<a href="#">IPv6 Configuration Guide</a>
Cisco IOS IPv6 features	<a href="#">Cisco IOS IPv6 Feature Mapping</a>

### Standards and RFCs

Standard/RFC	Title
RFCs for IPv6	<a href="#">IPv6 RFCs</a>

### Technical Assistance

Description	Link
The Cisco Support and Documentation website provides online resources to download documentation, software, and tools. Use these resources to install and configure the software and to troubleshoot and resolve technical issues with Cisco products and technologies. Access to most tools on the Cisco Support and Documentation website requires a Cisco.com user ID and password.	<a href="http://www.cisco.com/cisco/web/support/index.html">http://www.cisco.com/cisco/web/support/index.html</a>

## Feature Information for IPv6 Access Services: DHCPv6 Relay Agent

The following table provides release information about the feature or features described in this module. This table lists only the software release that introduced support for a given feature in a given software release train. Unless noted otherwise, subsequent releases of that software release train also support that feature.

Use Cisco Feature Navigator to find information about platform support and Cisco software image support. To access Cisco Feature Navigator, go to [www.cisco.com/go/cfn](http://www.cisco.com/go/cfn). An account on Cisco.com is not required.



Table 16: Feature Information for IPv6 Access Services: DHCPv6 Relay Agent

Feature Name	Releases	Feature Information
IPv6 Access Services: DHCPv6 Relay Agent		<p>A DHCP relay agent, which may reside on the client's link, is used to relay messages between the client and server.</p> <p>The following commands were introduced or modified: <b>ipv6 dhcp relay destination, show ipv6 dhcp interface.</b></p>
DHCPv6 Relay Agent Notification for Prefix Delegation		<p>DHCPv6 relay agent notification for prefix delegation allows the device working as a DHCPv6 relay agent to find prefix delegation options by reviewing the contents of a DHCPv6 packet that is being relayed by the relay agent to the client.</p>
DHCPv6 Relay: Reload Persistent Interface ID Option		<p>This feature makes the interface-ID option, which is used by relay agents to decide which interface should be used when forwarding a RELAY-REPLY packet, persistent.</p>





## CHAPTER 12

# IPv6 Access Services: Stateless DHCPv6

The stateless Dynamic Host Configuration Protocol for IPv6 (DHCPv6) feature allows DHCPv6 to be used for configuring a node with parameters that do not require a server to maintain any dynamic state for the node.

- [Finding Feature Information, on page 181](#)
- [Information About IPv6 Access Services: Stateless DHCPv6, on page 181](#)
- [How to Configure IPv6 Access Services: Stateless DHCPv6, on page 182](#)
- [Configuration Examples for IPv6 Access Services: Stateless DHCPv6, on page 189](#)
- [Additional References, on page 189](#)
- [Feature Information for IPv6 Access Services: Stateless DHCPv6, on page 190](#)

## Finding Feature Information

Your software release may not support all the features documented in this module. For the latest caveats and feature information, see [Bug Search Tool](#) and the release notes for your platform and software release. To find information about the features documented in this module, and to see a list of the releases in which each feature is supported, see the feature information table.

Use Cisco Feature Navigator to find information about platform support and Cisco software image support. To access Cisco Feature Navigator, go to [www.cisco.com/go/cfn](http://www.cisco.com/go/cfn). An account on Cisco.com is not required.

## Information About IPv6 Access Services: Stateless DHCPv6

### Information Refresh Server Option

The DHCPv6 information refresh option can specify an upper boundary for the length of time a client should wait before refreshing information retrieved from DHCPv6. This option is used with stateless DHCPv6, because there are no addresses or other entities with lifetimes that can tell the client when to contact the DHCPv6 server to refresh its configuration.

## SIP Server Options

Session initiation protocol (SIP) server options contain either a list of domain names or IPv6 addresses that can be mapped to one or more SIP outbound proxy servers. One option carries a list of domain names, and the other option carries a list of 128-bit IPv6 addresses.

SIP is an application-layer control protocol that can establish, modify and terminate multimedia sessions or calls. A SIP system has several logical components: user agents, proxy servers, redirect servers, and registrars. User agents may contain SIP clients; proxy servers always contain SIP clients.

## SNTP Server Option

The SNTP server option provides a list of one or more IPv6 addresses of SNTP servers available to the client for synchronization. The clients use these SNTP servers to synchronize their system time to that of the standard time servers. The server may list the SNTP servers in decreasing order of preference, but clients must treat the list of SNTP servers as an ordered list.

# How to Configure IPv6 Access Services: Stateless DHCPv6

## Configuring the Stateless DHCPv6 Function

The server maintains no state related to clients; for example, no prefix pools and records of allocation are maintained. Therefore, this function is “stateless” DHCPv6.

## Configuring the Stateless DHCPv6 Server

### SUMMARY STEPS

1. **enable**
2. **configure terminal**
3. **ipv6 dhcp pool *poolname***
4. **dns-server *ipv6-address***
5. **domain-name *domain***
6. **exit**
7. **interface *type number***
8. **ipv6 dhcp server *poolname* [**rapid-commit**] [**preference *value***] [**allow-hint**]**
9. **ipv6 nd other-config flag**
10. **end**

### DETAILED STEPS

	Command or Action	Purpose
Step 1	<b>enable</b> <b>Example:</b> Device> enable	Enables privileged EXEC mode. <ul style="list-style-type: none"> <li>• Enter your password if prompted.</li> </ul>

	Command or Action	Purpose
<b>Step 2</b>	<b>configure terminal</b> <b>Example:</b>  Device# configure terminal	Enters global configuration mode.
<b>Step 3</b>	<b>ipv6 dhcp pool <i>poolname</i></b> <b>Example:</b>  Device(config)# ipv6 dhcp pool dhcp-pool	Configures a Dynamic Host Configuration Protocol for IPv6 (DHCPv6) configuration information pool and enters DHCPv6 pool configuration mode.
<b>Step 4</b>	<b>dns-server <i>ipv6-address</i></b> <b>Example:</b>  Device(config-dhcp)# dns-server 2001:DB8:3000:3000::42	Specifies the Domain Name System (DNS) IPv6 servers available to a DHCPv6 client.
<b>Step 5</b>	<b>domain-name <i>domain</i></b> <b>Example:</b>  Device(config-dhcp)# domain-name example.com	Configures a domain name for a DHCPv6 client.
<b>Step 6</b>	<b>exit</b> <b>Example:</b>  Device(config-dhcp)# exit	Exits DHCPv6 pool configuration mode, and returns the device to global configuration mode.
<b>Step 7</b>	<b>interface <i>type number</i></b> <b>Example:</b>  Device(config)# interface serial 3	Specifies an interface type and number, and places the device in interface configuration mode.
<b>Step 8</b>	<b>ipv6 dhcp server <i>poolname</i> [<b>rapid-commit</b>] [<b>preference value</b>] [<b>allow-hint</b>]</b> <b>Example:</b>  Device(config-if)# ipv6 dhcp server dhcp-pool	Enables DHCPv6 on an interface.
<b>Step 9</b>	<b>ipv6 nd other-config flag</b> <b>Example:</b>  Device(config-if)# ipv6 nd other-config flag	Sets the “other stateful configuration” flag in IPv6 router advertisements (RAs).
<b>Step 10</b>	<b>end</b> <b>Example:</b>  Device(config-if)# end	Returns to privileged EXEC mode.

## Configuring the Stateless DHCPv6 Client

### SUMMARY STEPS

1. **enable**
2. **configure terminal**
3. **interface** *type number*
4. **ipv6 address autoconfig** [default]
5. **end**

### DETAILED STEPS

	Command or Action	Purpose
<b>Step 1</b>	<b>enable</b> <b>Example:</b> Device> enable	Enables privileged EXEC mode. <ul style="list-style-type: none"> <li>• Enter your password if prompted.</li> </ul>
<b>Step 2</b>	<b>configure terminal</b> <b>Example:</b> Device# configure terminal	Enters global configuration mode.
<b>Step 3</b>	<b>interface</b> <i>type number</i> <b>Example:</b> Device(config)# interface serial 3	Specifies an interface type and number, and places the device in interface configuration mode.
<b>Step 4</b>	<b>ipv6 address autoconfig</b> [default] <b>Example:</b> Device(config-if)# ipv6 address autoconfig	Enables automatic configuration of IPv6 addresses using stateless autoconfiguration on an interface and enables IPv6 processing on the interface.
<b>Step 5</b>	<b>end</b> <b>Example:</b> Device(config-if)# end	Returns to privileged EXEC mode.

## Enabling Processing of Packets with Source Routing Header Options

### SUMMARY STEPS

1. **enable**
2. **configure terminal**
3. **ipv6 source-route**
4. **end**

## DETAILED STEPS

	Command or Action	Purpose
Step 1	<b>enable</b> <b>Example:</b> Device> enable	Enables privileged EXEC mode. <ul style="list-style-type: none"> <li>• Enter your password if prompted.</li> </ul>
Step 2	<b>configure terminal</b> <b>Example:</b> Device# configure terminal	Enters global configuration mode.
Step 3	<b>ipv6 source-route</b> <b>Example:</b> Device(config)# ipv6 source-route	Enables processing of the IPv6 type 0 routing header.
Step 4	<b>end</b> <b>Example:</b> Device(config-if)# end	Returns to privileged EXEC mode.

## Importing Stateless DHCPv6 Server Options

## SUMMARY STEPS

1. enable
2. configure terminal
3. ipv6 dhcp pool *poolname*
4. import dns-server
5. import domain-name
6. end

## DETAILED STEPS

	Command or Action	Purpose
Step 1	<b>enable</b> <b>Example:</b> Router> enable	Enables privileged EXEC mode. <ul style="list-style-type: none"> <li>• Enter your password if prompted.</li> </ul>
Step 2	<b>configure terminal</b> <b>Example:</b> Router# configure terminal	Enters global configuration mode.

## Configuring the Sntp Server Option

	Command or Action	Purpose
<b>Step 3</b>	<b>ipv6 dhcp pool</b> <i>poolname</i> <b>Example:</b>  Router(config)# ipv6 dhcp pool pool1	Configures a DHCPv6 configuration information pool and enters DHCPv6 pool configuration mode.
<b>Step 4</b>	<b>import dns-server</b> <b>Example:</b>  Router(config-dhcp)# import dns-server	Imports the DNS recursive name server option to a DHCPv6 client.
<b>Step 5</b>	<b>import domain-name</b> <b>Example:</b>  Router(config-dhcp)# import domain-name	Imports the domain search list option to a DHCPv6 client.
<b>Step 6</b>	<b>end</b> <b>Example:</b>  Router(config-dhcp)# end	Returns to privileged EXEC mode.

## Configuring the Sntp Server Option

## SUMMARY STEPS

1. enable
2. configure terminal
3. ipv6 dhcp pool *poolname*
4. sntp address *ipv6-address*
5. end

## DETAILED STEPS

	Command or Action	Purpose
<b>Step 1</b>	<b>enable</b> <b>Example:</b>  Device> enable	Enables privileged EXEC mode.  • Enter your password if prompted.
<b>Step 2</b>	<b>configure terminal</b> <b>Example:</b>  Device# configure terminal	Enters global configuration mode.
<b>Step 3</b>	<b>ipv6 dhcp pool</b> <i>poolname</i> <b>Example:</b>	Configures a DHCPv6 configuration information pool and enters DHCPv6 pool configuration mode.



	Command or Action	Purpose
	Device(config)# ipv6 dhcp pool pool1	
<b>Step 4</b>	<b>sntp address</b> <i>ipv6-address</i> <b>Example:</b> Device(config-dhcp)# sntp address 2001:DB8:2000:2000::33	Specifies the SNTP server list to be sent to the client.
<b>Step 5</b>	<b>end</b> <b>Example:</b> Device(config-dhcp)# end	Returns to privileged EXEC mode.

## Importing SIP Server Information

### SUMMARY STEPS

1. **enable**
2. **configure terminal**
3. **ipv6 dhcp pool** *poolname*
4. **import sip address**
5. **import sip domain-name**
6. **end**

### DETAILED STEPS

	Command or Action	Purpose
<b>Step 1</b>	<b>enable</b> <b>Example:</b> Router> enable	Enables privileged EXEC mode. <ul style="list-style-type: none"> <li>• Enter your password if prompted.</li> </ul>
<b>Step 2</b>	<b>configure terminal</b> <b>Example:</b> Router# configure terminal	Enters global configuration mode.
<b>Step 3</b>	<b>ipv6 dhcp pool</b> <i>poolname</i> <b>Example:</b> Router(config)# ipv6 dhcp pool pool1	Configures a DHCPv6 configuration information pool and enters DHCPv6 pool configuration mode.
<b>Step 4</b>	<b>import sip address</b> <b>Example:</b> Router(config-dhcp)# import sip address	Imports the SIP server IPv6 address list option to the outbound SIP proxy server.

## Importing the SNTP Server Option

	Command or Action	Purpose
<b>Step 5</b>	<b>import sip domain-name</b> <b>Example:</b> <pre>Router(config-dhcp)# import sip domain-name</pre>	Imports a SIP server domain-name list option to the outbound SIP proxy server.
<b>Step 6</b>	<b>end</b> <b>Example:</b> <pre>Router(config-dhcp)# end</pre>	Returns to privileged EXEC mode.

## Importing the SNTP Server Option

## SUMMARY STEPS

1. **enable**
2. **configure terminal**
3. **ipv6 dhcp pool *poolname***
4. **import sntp address *ipv6-address***
5. **end**

## DETAILED STEPS

	Command or Action	Purpose
<b>Step 1</b>	<b>enable</b> <b>Example:</b> <pre>Device&gt; enable</pre>	Enables privileged EXEC mode. <ul style="list-style-type: none"> <li>• Enter your password if prompted.</li> </ul>
<b>Step 2</b>	<b>configure terminal</b> <b>Example:</b> <pre>Device# configure terminal</pre>	Enters global configuration mode.
<b>Step 3</b>	<b>ipv6 dhcp pool <i>poolname</i></b> <b>Example:</b> <pre>Device(config)# ipv6 dhcp pool pool1</pre>	Configures a DHCPv6 configuration information pool and enters DHCPv6 pool configuration mode.
<b>Step 4</b>	<b>import sntp address <i>ipv6-address</i></b> <b>Example:</b> <pre>Device(config-dhcp)# import sntp address 2001:DB8:2000:2000::33</pre>	Imports the SNTP server option to a DHCPv6 client.
<b>Step 5</b>	<b>end</b> <b>Example:</b>	Returns to privileged EXEC mode.

	Command or Action	Purpose
	Device(config-dhcp)# end	

## Configuration Examples for IPv6 Access Services: Stateless DHCPv6

### Example: Configuring the Stateless DHCPv6 Function

The following example shows how to use the DHCPv6 function to configure clients with information about the name lookup system. The server is configured with a DHCP pool, which contains the name lookup information that is to be passed to clients. It does not need to contain a prefix pool. This DHCP pool is attached to the access link to customers (GigabitEthernet0/0/0) using the **ipv6 dhcp server** command. The access link also has the **ipv6 nd other-config-flag** command enabled. RA messages sent from this interface will inform clients that they should use DHCPv6 for “other” (for example, nonaddress) configuration information.

```

ipv6 dhcp pool dhcp-pool
 dns-server 2001:DB8:A:B::1
 dns-server 2001:DB8:3000:3000::42
 domain-name example.com
!
interface GigabitEthernet0/0/0
 description Access link down to customers
 ipv6 address 2001:DB8:1234:42::1/64
 ipv6 nd other-config-flag
 ipv6 dhcp server dhcp-pool

```

The client has no obvious DHCPv6 configuration. However, the **ipv6 address autoconfig** command on the uplink to the service provider (GigabitEthernet 0/0/0) causes the following two events:

- Addresses are autoconfigured on the interface, based on prefixes in RA messages received from the server.
- If received RA messages have the “other configuration” flag set, the interface will attempt to acquire the other (for example, nonaddress) configuration from any DHCPv6 servers.

## Additional References

### Related Documents

Related Topic	Document Title
IPv6 addressing and connectivity	<i>IPv6 Configuration Guide</i>
Cisco IOS commands	<i>Cisco IOS Master Commands List, All Releases</i>

Related Topic	Document Title
IPv6 commands	<i>Cisco IOS IPv6 Command Reference</i>
Cisco IOS IPv6 features	<a href="#">Cisco IOS IPv6 Feature Mapping</a>

### Standards and RFCs

Standard/RFC	Title
RFCs for IPv6	<i>IPv6 RFCs</i>

### MIBs

MIB	MIBs Link
	To locate and download MIBs for selected platforms, Cisco IOS releases, and feature sets, use Cisco MIB Locator found at the following URL: <a href="http://www.cisco.com/go/mibs">http://www.cisco.com/go/mibs</a>

### Technical Assistance

Description	Link
The Cisco Support and Documentation website provides online resources to download documentation, software, and tools. Use these resources to install and configure the software and to troubleshoot and resolve technical issues with Cisco products and technologies. Access to most tools on the Cisco Support and Documentation website requires a Cisco.com user ID and password.	<a href="http://www.cisco.com/cisco/web/support/index.html">http://www.cisco.com/cisco/web/support/index.html</a>

## Feature Information for IPv6 Access Services: Stateless DHCPv6

The following table provides release information about the feature or features described in this module. This table lists only the software release that introduced support for a given feature in a given software release train. Unless noted otherwise, subsequent releases of that software release train also support that feature.

Use Cisco Feature Navigator to find information about platform support and Cisco software image support. To access Cisco Feature Navigator, go to [www.cisco.com/go/cfn](http://www.cisco.com/go/cfn). An account on Cisco.com is not required.

Table 17: Feature Information for IPv6 Access Services: Stateless DHCPv6

Feature Name	Releases	Feature Information
IPv6 Access Services: Stateless DHCPv6	Cisco IOS XE Release 2.5 Cisco IOS XE Release 3.9S	<p>Stateless DHCPv6 allows DHCPv6 to be used for configuring a node with parameters that do not require a server to maintain any dynamic state for the node.</p> <p>The following commands were introduced or modified: <b>dns-server</b>, <b>domain-name</b>, <b>import dns-server</b>, <b>import domain-name</b>, <b>import sip address</b>, <b>import sip domain-name</b>, <b>import sntp address</b>, <b>ipv6 address autoconfig</b>, <b>ipv6 dhcp pool</b>, <b>ipv6 dhcp server</b>, <b>ipv6 nd other-config-flag</b>, <b>ipv6 source-route</b>, <b>sntp address</b>.</p>





## CHAPTER 13

# IPv6 Access Services: DHCPv6 Prefix Delegation

The Dynamic Host Configuration Protocol for IPv6 (DHCPv6) prefix delegation feature can be used to manage link, subnet, and site addressing changes.

- [Finding Feature Information, on page 193](#)
- [Information About IPv6 Access Services: DHCPv6 Prefix Delegation, on page 193](#)
- [How to Configure IPv6 Access Services: DHCPv6 Prefix Delegation, on page 198](#)
- [Configuration Examples for IPv6 Access Services: DHCPv6 Prefix Delegation, on page 202](#)
- [Additional References, on page 206](#)
- [Feature Information for IPv6 Access Services: DHCPv6 Prefix Delegation, on page 207](#)

## Finding Feature Information

Your software release may not support all the features documented in this module. For the latest caveats and feature information, see [Bug Search Tool](#) and the release notes for your platform and software release. To find information about the features documented in this module, and to see a list of the releases in which each feature is supported, see the feature information table.

Use Cisco Feature Navigator to find information about platform support and Cisco software image support. To access Cisco Feature Navigator, go to [www.cisco.com/go/cfn](http://www.cisco.com/go/cfn). An account on Cisco.com is not required.

## Information About IPv6 Access Services: DHCPv6 Prefix Delegation

### DHCPv6 Prefix Delegation

The IPv6 Access Services—DHCPv6 Prefix Delegation feature can be used to manage link, subnet, and site addressing changes. Dynamic Host Configuration Protocol for IPv6 (DHCPv6) can be used in environments to deliver stateful and stateless information, which are defined as follows:

- **Stateful prefix delegation**—Address assignment is centrally managed and clients must obtain configuration information such as address autoconfiguration and neighbor discovery that is not available through protocols.

- Stateless prefix delegation—Stateless configuration parameters do not require a server to maintain any dynamic state for individual clients, such as Domain Name System (DNS) server addresses and domain search list options.

Extensions to DHCPv6 also enable prefix delegation, through which an ISP can automate the process of assigning prefixes to a customer for use within the customer's network. The prefix delegation occurs between a provider edge (PE) device and customer premises equipment (CPE) using the DHCPv6 prefix delegation option. Once the ISP has delegated prefixes to a customer, the customer may further subnet and assign prefixes to the links in the customer's network.

## Configuring Nodes Without Prefix Delegation

Stateless DHCPv6 allows DHCPv6 to be used for configuring a node with parameters that do not require a server to maintain any dynamic state for the node. The use of stateless DHCP is controlled by router advertisement (RA) messages multicasted by routers. The Cisco IOS XE DHCPv6 client will invoke stateless DHCPv6 when it receives an RA. The Cisco IOS XE DHCPv6 server will respond to a stateless DHCPv6 request with configuration parameters, such as the DNS servers and domain search list options.

## Client and Server Identification

Each DHCPv6 client and server is identified by a DHCP unique identifier (DUID). The DUID is carried in client identifier and server identifier options. The DUID is unique across all DHCP clients and servers, and it is stable for any specific client or server. DHCPv6 uses DUIDs based on link-layer addresses for both the client and server identifier. The device uses the MAC address from the lowest-numbered interface to form the DUID. The network interface is assumed to be permanently attached to the device.

When a DHCPv6 client requests two prefixes with the same DUID but with different identity association identifiers (IAIDs) on two different interfaces, these prefixes are considered to be for two different clients, and the interface information is maintained for both.

## Rapid Commit

The DHCPv6 client can obtain configuration parameters from a server either through a rapid two-message exchange (solicit, reply) or through a four-message exchange (solicit, advertise, request, and reply). By default, the four-message exchange is used. When the rapid-commit option is enabled by both the client and the server, the two-message exchange is used.

## DHCPv6 Client, Server, and Relay Functions

The DHCPv6 client, server, and relay functions are mutually exclusive on an interface. When one of these functions is enabled and a user tries to configure a different function on the same interface, one of the following messages is displayed: "Interface is in DHCP client mode," "Interface is in DHCP server mode," or "Interface is in DHCP relay mode."

The following sections describe these functions:

### Client Function

The DHCPv6 client function can be enabled on individual IPv6-enabled interfaces.



#### Note

You need APPX license package to enable the DHCPv6 client function on the device.



The DHCPv6 client can request and accept those configuration parameters that do not require a server to maintain any dynamic state for individual clients, such as DNS server addresses and domain search list options.

The DHCPv6 client can also request the delegation of prefixes. The prefixes acquired from a delegating device will be stored in a local IPv6 general prefix pool. The prefixes in the general prefix pool can then be referred to from other applications; for example, the general prefix pool can be used to number device downstream interfaces.

### Server Selection

A DHCPv6 client builds a list of potential servers by sending a solicit message and by collecting advertise message replies from servers. These messages are ranked based on the preference value, and servers may add a preference option to their advertise messages explicitly stating their preference value. If the client needs to acquire prefixes from servers, only servers that have advertised prefixes are considered.

### IAPD and IAID

An Identity Association for Prefix Delegation (IAPD) is a collection of prefixes assigned to a requesting device. A requesting device may have more than one IAPD; for example, one for each of its interfaces.

Each IAPD is identified by an IAID. The IAID is chosen by the requesting device and is unique among the IAPD IAIDs on the requesting device. IAIDs are made consistent across reboots by using information from the associated network interface, which is assumed to be permanently attached to the device.

## Server Function

The DHCPv6 server function can be enabled on individual IPv6-enabled interfaces.

The DHCPv6 server can provide configuration parameters that do not require the server to maintain any dynamic state for individual clients, such as DNS server addresses and domain search list options. The DHCPv6 server may be configured to perform prefix delegation.

All the configuration parameters for clients are independently configured into DHCPv6 configuration pools, which are stored in the NVRAM. A configuration pool can be associated with a particular DHCPv6 server on an interface when it is started. Prefixes that are to be delegated to clients may be specified either as a list of preassigned prefixes for a particular client or as IPv6 local prefix pools that are also stored in the NVRAM. The list of manually configured prefixes or IPv6 local prefix pools can be referenced and used by DHCPv6 configuration pools.

The DHCPv6 server maintains an automatic binding table in memory to track the assignment of some configuration parameters, such as prefixes between the server and its clients. Automatic bindings can be stored permanently in the database agent, such as a remote TFTP server or a local NVRAM file system.

### Configuration Information Pool

A DHCPv6 configuration information pool is a named entity that includes information about available configuration parameters and policies that the control assignment of the parameters to clients from the pool. A pool is configured independently and is associated with the DHCPv6 service through the CLI.

Each configuration pool can contain the following configuration parameters and operational information:

- Prefix delegation information, which includes:
  - A prefix pool name and associated preferred and valid lifetimes
  - A list of available prefixes for a particular client and associated preferred and valid lifetimes
- A list of IPv6 addresses of DNS servers

- A domain search list, which is a string containing domain names for the DNS resolution

### DHCP for IPv6 Address Assignment

DHCPv6 enables DHCP servers to pass configuration parameters, such as IPv6 network addresses, to IPv6 clients. The DHCPv6 Individual Address Assignment feature manages nonduplicate address assignment in the correct prefix based on the network where the host is connected. Assigned addresses can be from one or multiple prefix pools. Additional options, such as the default domain and DNS name-server address, can be passed back to the client. Address pools can be assigned for use on a specific interface or on multiple interfaces, or the server can automatically find the appropriate pool.

### Prefix Assignment

A prefix-delegating router (DHCPv6 server) selects prefixes to be assigned to a requesting router (DHCPv6 client) upon receiving a request from the client. The server can select prefixes for a requesting client by using static and dynamic assignment mechanisms. Administrators can manually configure a list of prefixes and associated preferred and valid lifetimes for an IAPD of a specific client that is identified by its DUID.

When the delegating router receives a request from a client, it checks if there is a static binding configured for the IAPD in the client's message. If a static binding is present, the prefixes in the binding are returned to the client. If no such binding is found, the server attempts to assign prefixes for the client from other sources.

The Cisco IOS XE DHCPv6 server can assign prefixes dynamically from an IPv6 local prefix pool. When the server receives a prefix request from a client, it attempts to obtain unassigned prefixes from the pool. After the client releases the previously assigned prefixes, the server returns them to the pool for reassignment.

An IPv6 prefix delegating router can also select prefixes for a requesting router based on an external authority such as a RADIUS server using the Framed-IPv6-Prefix attribute.

### Automatic Binding

Each DHCPv6 configuration pool has an associated binding table. The binding table contains records of all prefixes in the configuration pool that have been explicitly delegated to clients. Each entry in the binding table contains the following information:

- Client DUID.
- Client IPv6 address.
- A list of IAPDs associated with the client.
- A list of prefixes delegated to each IAPD.
- Preferred and valid lifetimes for each prefix.
- The configuration pool to which this binding table belongs.
- The network interface on which the server that is using the pool is running.

A binding table entry is automatically created whenever a prefix is delegated to a client from the configuration pool, and the entry is updated when the client renews, rebinds, or confirms the prefix delegation. A binding table entry is deleted when the client voluntarily releases all the prefixes in the binding, the valid lifetimes of all prefixes have expired, or administrators run the **clear ipv6 dhcp binding** command.

## Binding Database

Each permanent storage to which the binding database is saved is called the database agent. A database agent can be a remote host, such as an FTP server, or a local file system, such as the NVRAM.

Automatic bindings are maintained in the RAM and can be saved to some permanent storage so that information about configurations, such as prefixes assigned to clients, is not lost after a system reload. The bindings are stored as text records for easy maintenance. Each record contains the following information:

- DHCPv6 pool name from which the configuration was assigned to the client.
- Interface identifier from which the client requests were received.
- The client IPv6 address.
- The client DUID.
- IAID of the IAPD.
- Prefix delegated to the client.
- The prefix length.
- The prefix preferred lifetime in seconds.
- The prefix valid lifetime in seconds.
- The prefix expiration time stamp.
- Optional local prefix pool name from which the prefix was assigned.

## DHCPv6 Server Stateless Autoconfiguration

Hierarchical DHCPv6 for stateless configuration parameters allows a stateless or stateful DHCPv6 client to export configuration parameters (DHCPv6 options) to a local DHCPv6 server pool. The local DHCPv6 server can then provide the imported configuration parameters to other DHCPv6 clients.

The figure below shows a typical broadband deployment.

**Figure 15: Broadband Topology**

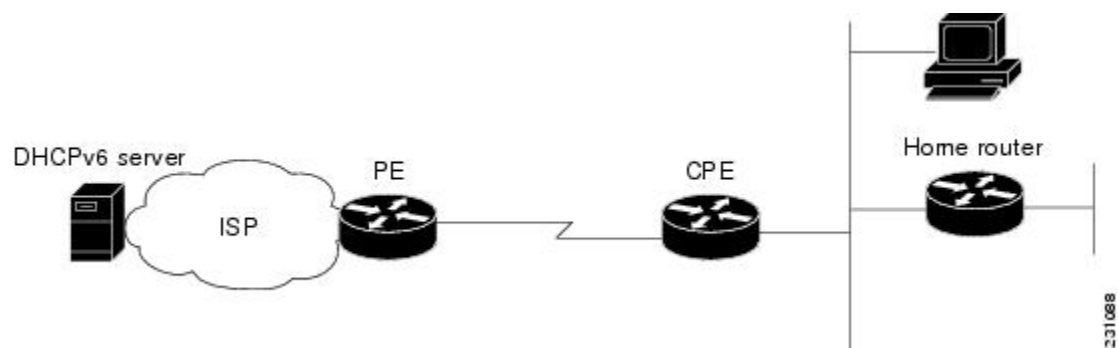

The CPE interface towards the PE can be a stateless or stateful DHCPv6 client. In either case, the ISP-side DHCPv6 server may provide configuration parameters such as DNS server addresses, domain names, and Simple Network Time Protocol (SNTP) servers to the DHCP client on the CPE. Such information can be specific to ISPs.

In addition to being a DHCPv6 client (for example, towards the ISP), the CPE may act as a DHCPv6 server to the home network. For example, neighbor discovery followed by a stateless or stateful DHCPv6 client can occur on the link between the CPE and the home devices (such as the home router or PC). In some cases, the information to be provided to the home network is the same as that obtained from the ISP-side DHCPv6 server. Because this information can be dynamically changed, it cannot be hard-configured in the CPE's configuration. Therefore, the DHCPv6 component on the CPE allows automatic importing of configuration parameters from the DHCPv6 client to the DHCPv6 server pool.

DHCPv6 supports the following options for IPv6 on the server:

#### **Information Refresh Server Option**

The DHCPv6 information refresh option can specify a maximum limit for the length of time a client should wait before refreshing the information retrieved from DHCPv6. This option is used with stateless DHCPv6 because there are no addresses or other entities with lifetimes that can tell the client when to contact the DHCPv6 server to refresh its configuration.

#### **NIS- and NIS+-Related Server Options**

Users can configure the network information service (NIS) or NIS plus (NIS+) address or domain name of a DHCPv6 server using NIS- and NIS+-related options, and then import that information to the DHCPv6 client.

#### **SIP Server Options**

Session Initiation Protocol (SIP) server options contain either a list of domain names or a list of IPv6 addresses that can be mapped to one or more SIP outbound proxy servers. One option carries a list of domain names, and the other option carries a list of 128-bit IPv6 addresses.

SIP is an application-layer control protocol that can establish, modify, and terminate multimedia sessions or calls. A SIP system has several logical components: user agents, proxy servers, redirect servers, and registrars. User agents may contain SIP clients; proxy servers always contain SIP clients.

#### **SNTP Server Option**

The SNTP server option provides a list of one or more IPv6 addresses of SNTP servers available to the client for synchronization. Clients use these SNTP servers to synchronize their system time to that of the standard time servers. The DHCPv6 server may list the SNTP servers in decreasing order of preference, but clients treat the list of SNTP servers as an ordered list.

# How to Configure IPv6 Access Services: DHCPv6 Prefix Delegation

## Configuring the DHCPv6 Server Function

### Configuring the DHCPv6 Configuration Pool

#### SUMMARY STEPS

1. `enable`

2. **configure terminal**
3. **ipv6 dhcp pool** *poolname*
4. **domain-name** *domain*
5. **dns-server** *ipv6-address*
6. **prefix-delegation** *ipv6-prefix / prefix-length client-duid* [**iaid** *iaid*] [*lifetime*]
7. **prefix-delegation pool** *poolname* [**lifetime** *valid-lifetime preferred-lifetime*]
8. **exit**
9. **interface** *type number*
10. **ipv6 dhcp server** *poolname* [**rapid-commit**] [**preference** *value*] [**allow-hint**]
11. **end**

## DETAILED STEPS

	Command or Action	Purpose
<b>Step 1</b>	<b>enable</b> <b>Example:</b> Device> enable	Enables privileged EXEC mode. <ul style="list-style-type: none"> <li>• Enter your password if prompted.</li> </ul>
<b>Step 2</b>	<b>configure terminal</b> <b>Example:</b> Device# configure terminal	Enters global configuration mode.
<b>Step 3</b>	<b>ipv6 dhcp pool</b> <i>poolname</i> <b>Example:</b> Device(config)# ipv6 dhcp pool pool1	Configures a DHCPv6 configuration information pool and enters DHCPv6 pool configuration mode.
<b>Step 4</b>	<b>domain-name</b> <i>domain</i> <b>Example:</b> Device(config-dhcp)# domain-name example.com	Configures a domain name for a DHCPv6 client.
<b>Step 5</b>	<b>dns-server</b> <i>ipv6-address</i> <b>Example:</b> Device(config-dhcp)# dns-server 2001:DB8:3000:3000::42	Specifies the DNS IPv6 servers available to a DHCPv6 client.
<b>Step 6</b>	<b>prefix-delegation</b> <i>ipv6-prefix / prefix-length client-duid</i> <b>[iaid</b> <i>iaid</i> ] [ <i>lifetime</i> ] <b>Example:</b> Device(config-dhcp)# prefix-delegation 2001:DB8:1263::/48 0005000400F1A4D070D03	Specifies a manually configured numeric prefix to be delegated to a specified client's IAPD.

	Command or Action	Purpose
<b>Step 7</b>	<p><b>prefix-delegation pool</b> <i>poolname</i> [<i>lifetime valid-lifetime preferred-lifetime</i>]</p> <p><b>Example:</b></p> <pre>Device(config-dhcp)# prefix-delegation pool pool1 lifetime 1800 60</pre>	Specifies a named IPv6 local prefix pool from which prefixes are delegated to DHCPv6 clients.
<b>Step 8</b>	<p><b>exit</b></p> <p><b>Example:</b></p> <pre>Device(config-dhcp)# exit</pre>	Exits DHCPv6 pool configuration mode, and returns the device to global configuration mode.
<b>Step 9</b>	<p><b>interface</b> <i>type number</i></p> <p><b>Example:</b></p> <pre>Device(config)# interface serial 3</pre>	Specifies an interface type and number, and enters interface configuration mode.
<b>Step 10</b>	<p><b>ipv6 dhcp server</b> <i>poolname</i> [<b>rapid-commit</b>] [<b>preference value</b>] [<b>allow-hint</b>]</p> <p><b>Example:</b></p> <pre>Device(config-if)# ipv6 dhcp server pool1</pre>	
<b>Step 11</b>	<p><b>end</b></p> <p><b>Example:</b></p> <pre>Device(config-if)# end</pre>	Returns to privileged EXEC mode.

## Configuring a Binding Database Agent for the Server Function

### SUMMARY STEPS

1. enable
2. configure terminal
3. ipv6 dhcp database *agent* [**write-delay seconds**] [**timeout seconds**]
4. end

### DETAILED STEPS

	Command or Action	Purpose
<b>Step 1</b>	<p><b>enable</b></p> <p><b>Example:</b></p> <pre>Device&gt; enable</pre>	<p>Enables privileged EXEC mode.</p> <ul style="list-style-type: none"> <li>• Enter your password if prompted.</li> </ul>

	Command or Action	Purpose
<b>Step 2</b>	<b>configure terminal</b> <b>Example:</b>  Device# configure terminal	Enters global configuration mode.
<b>Step 3</b>	<b>ipv6 dhcp database agent [write-delay seconds] [timeout seconds]</b> <b>Example:</b>  Device(config)# ipv6 dhcp database tftp://10.0.0.1/dhcp-binding	Specifies DHCPv6 binding database agent parameters.
<b>Step 4</b>	<b>end</b> <b>Example:</b>  Device(config)# end	Returns to privileged EXEC mode.

## Configuring the DHCPv6 Client Function

General prefixes can be defined dynamically from a prefix received by a DHCPv6 prefix delegation client. The delegated prefix is stored in a general prefix.

### SUMMARY STEPS

1. enable
2. configure terminal
3. interface *type number*
4. ipv6 dhcp client pd {*prefix-name* | hint *ipv6-prefix*} [rapid-commit]
5. end

### DETAILED STEPS

	Command or Action	Purpose
<b>Step 1</b>	<b>enable</b> <b>Example:</b>  Device> enable	Enables privileged EXEC mode. <ul style="list-style-type: none"> <li>• Enter your password if prompted.</li> </ul>
<b>Step 2</b>	<b>configure terminal</b> <b>Example:</b>  Device# configure terminal	Enters global configuration mode.
<b>Step 3</b>	<b>interface type number</b> <b>Example:</b>	Specifies an interface type and number, and enters interface configuration mode.

	Command or Action	Purpose
	Device(config)# interface fastethernet 0/0/0	
<b>Step 4</b>	<b>ipv6 dhcp client pd</b> { <i>prefix-name</i>   <b>hint</b> <i>ipv6-prefix</i> } <b>[rapid-commit]</b>  <b>Example:</b>  Device(config-if)# ipv6 dhcp client pd dhcp-prefix	Enables the DHCPv6 client process and enables a request for prefix delegation through a specified interface.
<b>Step 5</b>	<b>end</b>  <b>Example:</b>  Device(config-if)# end	Returns to privileged EXEC mode.

## Deleting Automatic Client Bindings from the DHCPv6 Binding Table

### SUMMARY STEPS

1. enable
2. clear ipv6 dhcp binding [*ipv6-address*] [**vrf** *vrf-name*]

### DETAILED STEPS

	Command or Action	Purpose
<b>Step 1</b>	<b>enable</b>  <b>Example:</b>  Device> enable	Enables privileged EXEC mode. <ul style="list-style-type: none"> <li>• Enter your password if prompted.</li> </ul>
<b>Step 2</b>	<b>clear ipv6 dhcp binding</b> [ <i>ipv6-address</i> ] [ <b>vrf</b> <i>vrf-name</i> ]  <b>Example:</b>  Device# clear ipv6 dhcp binding	Deletes automatic client bindings from the DHCPv6 binding table.

## Configuration Examples for IPv6 Access Services: DHCPv6 Prefix Delegation

### Example: Configuring the DHCPv6 Server Function

DHCPv6 clients are connected to the DHCPv6 server on Gigabit Ethernet interface 0/0/0. The server is configured to use parameters from the DHCP pool called dhcp-pool. This pool provides clients with the IPv6 address of a DNS server and the domain name to be used. It also specifies that prefixes can be delegated from the prefix pool called client-prefix-pool1. The prefixes delegated will have valid and preferred lifetimes of



1800 and 600 seconds respectively. The prefix pool named client-prefix-pool1 has a prefix of length /40 from which it will delegate (sub) prefixes of length /48.

```

ipv6 dhcp pool dhcp-pool
  prefix-delegation pool client-prefix-pool1 lifetime 1800 600
  dns-server 2001:DB8:3000:3000::42
  domain-name example.com
!

description downlink to clients
ipv6 address FEC0:240:104:2001::139/64
ipv6 dhcp server dhcp-pool
!
ipv6 local pool client-prefix-pool1 2001:DB8:1200::/40 48

```

The following example from the **show ipv6 dhcp** command shows the DUID of the device:

```
Router# show ipv6 dhcp
```

```
This device's DHCPv6 unique identifier(DUID): 000300010002FCA5DC1C
```

In the following example, the **show ipv6 dhcp binding** command shows information about two clients, including their DUIDs, IAPDs, prefixes, and preferred and valid lifetimes:

```
Router# show ipv6 dhcp binding
```

```

Client: FE80::202:FCFF:FEA5:DC39 (GigabitEthernet2/1/0)
  DUID: 000300010002FCA5DC1C
  IA PD: IA ID 0x00040001, T1 0, T2 0
    Prefix: 3FFE:C00:C18:11::/68
      preferred lifetime 180, valid lifetime 12345
      expires at Nov 08 2002 02:24 PM (12320 seconds)
Client: FE80::202:FCFF:FEA5:C039 (GigabitEthernet2/1/0)
  DUID: 000300010002FCA5C01C
  IA PD: IA ID 0x00040001, T1 0, T2 0
    Prefix: 3FFE:C00:C18:1::/72
      preferred lifetime 240, valid lifetime 54321
      expires at Nov 09 2002 02:02 AM (54246 seconds)
    Prefix: 3FFE:C00:C18:2::/72
      preferred lifetime 300, valid lifetime 54333
      expires at Nov 09 2002 02:03 AM (54258 seconds)
    Prefix: 3FFE:C00:C18:3::/72
      preferred lifetime 280, valid lifetime 51111

```

In the following example, the **show ipv6 dhcp database** command provides information on the binding database agents TFTP, NVRAM, and flash:

```
Router# show ipv6 dhcp database
```

```

Database agent tftp://172.19.216.133/db.tftp:
  write delay: 69 seconds, transfer timeout: 300 seconds
  last written at Jan 09 2003 01:54 PM,
    write timer expires in 56 seconds
  last read at Jan 06 2003 05:41 PM
  successful read times 1
  failed read times 0
  successful write times 3172
  failed write times 2
Database agent nvram:/dhcpv6-binding:
  write delay: 60 seconds, transfer timeout: 300 seconds
  last written at Jan 09 2003 01:54 PM,
    write timer expires in 37 seconds
  last read at never
  successful read times 0

```

## Example: Configuring the DHCPv6 Configuration Pool

```

failed read times 0
successful write times 3325
failed write times 0
Database agent flash:/dhcpv6-db:
write delay: 82 seconds, transfer timeout: 3 seconds
last written at Jan 09 2003 01:54 PM,
  write timer expires in 50 seconds
last read at never
successful read times 0
failed read times 0
successful write times 2220
failed write times 614

```

## Example: Configuring the DHCPv6 Configuration Pool

In the following example, the `show ipv6 dhcp pool` command provides information on the configuration pool named `svr-p1`, including the static bindings, prefix information, the DNS server, and the domain names found in the `svr-p1` pool:

```

Router# show ipv6 dhcp pool

DHCPv6 pool: svr-p1
Static bindings:
  Binding for client 000300010002FCA5C01C
    IA PD: IA ID 00040002,
      Prefix: 3FFE:C00:C18:3::/72
        preferred lifetime 604800, valid lifetime 2592000
    IA PD: IA ID not specified; being used by 00040001
      Prefix: 3FFE:C00:C18:1::/72
        preferred lifetime 240, valid lifetime 54321
      Prefix: 3FFE:C00:C18:2::/72
        preferred lifetime 300, valid lifetime 54333
      Prefix: 3FFE:C00:C18:3::/72
        preferred lifetime 280, valid lifetime 51111
  Prefix from pool: local-p1, Valid lifetime 12345, Preferred lifetime 180
  DNS server: 2001:DB8:1001::1
  DNS server: 2001:DB8:1001::2
  Domain name: example1.net
  Domain name: example2.net
  Domain name: example3.net
Active clients: 2
Current configuration : 22324 bytes
!
! Last configuration change at 14:59:38 PST Tue Jan 16 2001
! NVRAM config last updated at 04:25:39 PST Tue Jan 16 2001 by bird
!
hostname Router
!
ip cef
ipv6 unicast-routing
ipv6 cef
ipv6 cef accounting prefix-length
!
!
interface GigabitEthernet0/0/0
ip address 10.4.9.11 255.0.0.0
media-type 10BaseT
ipv6 address 2001:DB8:C18:1::/64 eui-64

```

## Example: Configuring the DHCPv6 Client Function

This DHCPv6 client has three interfaces: Gigabit Ethernet interface 0/0/0 is the upstream link to a service provider, which has a DHCPv6 server function enabled. The Fast Ethernet interfaces 0/0/0 and 0/1/0 are links to local networks.

The upstream interface, Gigabit Ethernet interface 0/0/0, has the DHCPv6 client function enabled. Prefixes delegated by the provider are stored in the general prefix called prefix-from-provider.

The local networks, Fast Ethernet interfaces 0/0/0 and 0/1/0, both assign interface addresses based on the general prefix called prefix-from-provider. The bits on the left of the addresses come from the general prefix, and the bits on the right of the addresses are specified statically.

```
interface GigabitEthernet 0/0/0
  description uplink to provider DHCP IPv6 server
  ipv6 dhcp client pd prefix-from-provider
!
interface FastEthernet 0/0/0
  description local network 0
  ipv6 address prefix-from-provider ::5:0:0:0:100/64
!
interface FastEthernet 0/1/0
  description local network 1
  ipv6 address prefix-from-provider ::6:0:0:0:100/64
```

## Example: Configuring a Database Agent for the Server Function

The DHCPv6 server is configured to store table bindings to the file named dhcp-binding on the server at address 10.0.0.1 using the TFTP protocol. The bindings are saved every 120 seconds.

```
ipv6 dhcp database tftp://10.0.0.1/dhcp-binding write-delay 120
```

The following example shows how to specify DHCP for IPv6 binding database agent parameters and store binding entries in bootflash:

```
ipv6 dhcp database bootflash
```

## Example: Displaying DHCP Server and Client Information on the Interface

The following is sample output from the **show ipv6 dhcp interface** command. In the first example, the command is used on a router that has an interface acting as a DHCPv6 server. In the second example, the command is used on a router that has an interface acting as a DHCPv6 client:

```
Router1# show ipv6 dhcp interface
```

```
is in server mode
Using pool: svr-pl
Preference value: 20
Rapid-Commit is disabled
```

```
Router2# show ipv6 dhcp interface
```

```
is in client mode
State is OPEN (1)
List of known servers:
  Address: FE80::202:FCFF:FEA1:7439, DUID 000300010002FCA17400
```

```

Preference: 20
IA PD: IA ID 0x00040001, T1 120, T2 192
  Prefix: 3FFE:C00:C18:1::/72
    preferred lifetime 240, valid lifetime 54321
    expires at Nov 08 2002 09:10 AM (54319 seconds)
  Prefix: 3FFE:C00:C18:2::/72
    preferred lifetime 300, valid lifetime 54333
    expires at Nov 08 2002 09:11 AM (54331 seconds)
  Prefix: 3FFE:C00:C18:3::/72
    preferred lifetime 280, valid lifetime 51111
    expires at Nov 08 2002 08:17 AM (51109 seconds)
DNS server: 2001:DB8:1001::1
DNS server: 2001:DB8:1001::2
Domain name: example1.net
Domain name: example2.net
Domain name: example3.net
Prefix name is cli-pl
Rapid-Commit is enabled

```

## Additional References

### Related Documents

Related Topic	Document Title
IPv6 addressing and connectivity	<i>IPv6 Configuration Guide</i>
Cisco IOS commands	<i>Cisco IOS Master Commands List, All Releases</i>
IPv6 commands	<i>Cisco IOS IPv6 Command Reference</i>
Cisco IOS IPv6 features	<i>Cisco IOS IPv6 Feature Mapping</i>

### Standards and RFCs

Standard/RFC	Title
RFCs for IPv6	<i>IPv6 RFCs</i>

### MIBs

MIB	MIBs Link
	To locate and download MIBs for selected platforms, Cisco IOS releases, and feature sets, use Cisco MIB Locator found at the following URL: <a href="http://www.cisco.com/go/mibs">http://www.cisco.com/go/mibs</a>

**Technical Assistance**

Description	Link
The Cisco Support and Documentation website provides online resources to download documentation, software, and tools. Use these resources to install and configure the software and to troubleshoot and resolve technical issues with Cisco products and technologies. Access to most tools on the Cisco Support and Documentation website requires a Cisco.com user ID and password.	<a href="http://www.cisco.com/cisco/web/support/index.html">http://www.cisco.com/cisco/web/support/index.html</a>

## Feature Information for IPv6 Access Services: DHCPv6 Prefix Delegation

*Table 18: Feature Information for IPv6 Access Services: DHCPv6 Prefix Delegation*

Feature Name	Releases	Feature Information
IPv6 Access Services: DHCPv6 Prefix Delegation		<p>The DHCPv6 Prefix Delegation feature can be used to manage link, subnet, and site addressing changes. DHCPv6 can be used in environments to deliver stateful and stateless information.</p> <p>The following commands were introduced or modified: <b>clear ipv6 dhcp binding, dns-server, domain-name, ipv6 dhcp client pd, ipv6 dhcp database, ipv6 dhcp pool, ipv6 dhcp server, prefix-delegation, prefix-delegation pool, show ipv6 dhcp, show ipv6 dhcp binding, show ipv6 dhcp interface, show ipv6 dhcp pool.</b></p>





## CHAPTER 14

# DHCP for IPv6 Broadband

The DHCP for IPv6 Broadband feature highlights the DHCP enhancements that support IPv6 broadband deployments. This feature briefly explains the different ways a delegating device selects prefixes for a requesting device, enabling accounting messages on a device, and forced release of delegated prefix bindings associated with a PPP virtual interface when the PPP virtual interface is terminated.

- [Finding Feature Information, on page 209](#)
- [Information About DHCP for IPv6 Broadband, on page 209](#)
- [How to Configure DHCP for IPv6 Broadband, on page 210](#)
- [Configuration Examples for DHCP for IPv6 Broadband, on page 212](#)
- [Additional References, on page 212](#)
- [Feature Information for DHCP for IPv6 Broadband, on page 213](#)

## Finding Feature Information

Your software release may not support all the features documented in this module. For the latest caveats and feature information, see [Bug Search Tool](#) and the release notes for your platform and software release. To find information about the features documented in this module, and to see a list of the releases in which each feature is supported, see the feature information table.

Use Cisco Feature Navigator to find information about platform support and Cisco software image support. To access Cisco Feature Navigator, go to [www.cisco.com/go/cfn](http://www.cisco.com/go/cfn). An account on Cisco.com is not required.

## Information About DHCP for IPv6 Broadband

### Prefix Delegation

An IPv6 prefix delegating device selects IPv6 prefixes to be assigned to a requesting device upon receiving a request from the client. The delegating device might select prefixes for a requesting device in the following ways:

- Dynamic assignment from a pool of available prefixes.
- Dynamic assignment from a pool name obtained from the RADIUS server.
- Assignment of prefix obtained from the RADIUS sever.

Contrary to IPv4 address assignment, an IPv6 user will be assigned a prefix, not a single address. Typically the Internet service provider (ISP) assigns a 64- or 48-bit prefix.

## Accounting Start and Stop Messages

PPP calls a registry to allow DHCPv6 to append the delegated prefix information to accounting start and stop messages. When accounting is configured for a DHCPv6 pool, accounting interim packets are sent to broadband sessions after binding is provided from the pool.

## Forced Release of a Binding

The DHCPv6 server maintains an automatic binding table in memory to track the assignment of some configuration parameters, such as prefixes between the server and its clients. The automatic bindings can be stored permanently in the database agent, which can be, for example, a remote TFTP server or local NVRAM file system.

DHCPv6 invokes a routine when the virtual interface used by PPP terminates. This routine automatically releases any delegated prefix bindings associated with the PPP virtual interface that is being terminated.

When a PPP virtual interface terminates, the routine runs through the full table of DHCPv6 bindings checking for the matching interface. Because PPP uses a virtual interface, this subroutine clears any related lease information when the PPP connection terminates.



---

**Note** In IPv6 broadband deployment using DHCPv6, you must enable release of prefix bindings associated with a PPP virtual interface using the **ipv6 dhcp binding track ppp** command. This ensures that DHCPv6 bindings are tracked together with PPP sessions, and in the event of DHCP REBIND failure, the client initiates DHCPv6 negotiation again.

---

# How to Configure DHCP for IPv6 Broadband

## Enabling the Sending of Accounting Start and Stop Messages

### SUMMARY STEPS

1. **enable**
2. **configure terminal**
3. **ipv6 dhcp pool *poolname***
4. **accounting *mlist***

### DETAILED STEPS

	Command or Action	Purpose
Step 1	<b>enable</b>  <b>Example:</b>  Device> enable	Enables privileged EXEC mode. <ul style="list-style-type: none"> <li>• Enter your password if prompted.</li> </ul>



	Command or Action	Purpose
<b>Step 2</b>	<b>configure terminal</b> <b>Example:</b>  Device# configure terminal	Enters global configuration mode.
<b>Step 3</b>	<b>ipv6 dhcp pool <i>poolname</i></b> <b>Example:</b>  Device(config)# ipv6 dhcp pool pool1	Configures a DHCP for IPv6 configuration information pool and enters DHCP for IPv6 pool configuration mode.
<b>Step 4</b>	<b>accounting <i>m</i>list</b> <b>Example:</b>  Device(config-dhcp)# accounting list1	Enables accounting start and stop messages to be sent.

## Removing Delegated Prefix Bindings

Perform this task to release any delegated prefix bindings associated with the PPP virtual interface that is being terminated.

### SUMMARY STEPS

1. **enable**
2. **configure terminal**
3. **interface *type number***
4. **ipv6 dhcp bindings track ppp**

### DETAILED STEPS

	Command or Action	Purpose
<b>Step 1</b>	<b>enable</b> <b>Example:</b>  Device> enable	Enables privileged EXEC mode. <ul style="list-style-type: none"> <li>• Enter your password if prompted.</li> </ul>
<b>Step 2</b>	<b>configure terminal</b> <b>Example:</b>  Device# configure terminal	Enters global configuration mode.
<b>Step 3</b>	<b>interface <i>type number</i></b> <b>Example:</b>  Device(config)# interface VirtualAccess2.2	Specifies an interface type and number, and places the router in interface configuration mode.

	Command or Action	Purpose
<b>Step 4</b>	<b>ipv6 dhcp bindings track ppp</b> <b>Example:</b> Device(config-if)# ipv6 dhcp bindings track ppp	Releases any delegated prefix leases associated with the PPP virtual interface that is being terminated.

## Configuration Examples for DHCP for IPv6 Broadband

### Example: Enabling the Sending of Accounting Start and Stop Messages

This example shows how to enable a device to send accounting start and stop messages.

```
Device(config)# ipv6 dhcp pool pool1
Device(config-dhcp)# accounting list1
```

### Example: Configuration for a Prefix Allocated from a Local Pool

DHCPv6 clients are connected to the DHCPv6 server on Gigabit Ethernet interface 0/0/0. The server is configured to use parameters from the DHCP pool called dhcp-pool. This pool provides clients with the IPv6 address of a DNS server and the domain name to be used. It also specifies that prefixes can be delegated from the prefix pool called client-prefix-pool1. The prefixes delegated will have valid and preferred lifetimes of 1800 and 600 seconds respectively. The prefix pool named client-prefix-pool1 has a prefix of length /40 from which it will delegate (sub) prefixes of length /48.

```
ipv6 dhcp pool dhcp-pool
 prefix-delegation pool client-prefix-pool1 lifetime 1800 600
 dns-server 2001:DB8:3000:3000::42
 domain-name example.com
!
interface GigabitEthernet0/0/0
 description downlink to clients
 ipv6 address FEC0:240:104:2001::139/64
 ipv6 dhcp server dhcp-pool
!
ipv6 local pool client-prefix-pool1 2001:DB8:1200::/40 48
```

## Additional References

### Related Documents

Related Topic	Document Title
IPv6 addressing and connectivity	<i>IPv6 Configuration Guide</i>

Related Topic	Document Title
Cisco IOS commands	<a href="#">Cisco IOS Master Commands List, All Releases</a>
IPv6 commands	<a href="#">Cisco IOS IPv6 Command Reference</a>
Cisco IOS IPv6 features	<a href="#">Cisco IOS IPv6 Feature Mapping</a>

### Standards and RFCs

Standard/RFC	Title
RFCs for IPv6	<i>IPv6 RFCs</i>

### MIBs

MIB	MIBs Link
	To locate and download MIBs for selected platforms, Cisco IOS releases, and feature sets, use Cisco MIB Locator found at the following URL: <a href="http://www.cisco.com/go/mibs">http://www.cisco.com/go/mibs</a>

### Technical Assistance

Description	Link
The Cisco Support and Documentation website provides online resources to download documentation, software, and tools. Use these resources to install and configure the software and to troubleshoot and resolve technical issues with Cisco products and technologies. Access to most tools on the Cisco Support and Documentation website requires a Cisco.com user ID and password.	<a href="http://www.cisco.com/cisco/web/support/index.html">http://www.cisco.com/cisco/web/support/index.html</a>

## Feature Information for DHCP for IPv6 Broadband

The following table provides release information about the feature or features described in this module. This table lists only the software release that introduced support for a given feature in a given software release train. Unless noted otherwise, subsequent releases of that software release train also support that feature.

Use Cisco Feature Navigator to find information about platform support and Cisco software image support. To access Cisco Feature Navigator, go to [www.cisco.com/go/cfn](http://www.cisco.com/go/cfn). An account on Cisco.com is not required.

Table 19: Feature Information for DHCP for IPv6 Broadband

Feature Name	Releases	Feature Information
DHCP Enhancements to Support IPv6 Broadband Deployments	Cisco IOS XE Release 2.5	<p>The feature highlights the DHCP enhancements that support IPv6 broadband deployments, such as, the different ways a delegating device selects prefixes for a requesting device, enabling accounting messages on a device, and forced release of delegated prefix bindings associated with a PPP virtual interface when the PPP virtual interface is terminated.</p> <p>The following commands were introduced or modified:  <b>accounting, ipv6 dhcp bindings track ppp, ipv6 dhcp pool.</b></p>
DHCPv6 Prefix Delegation RADIUS VSA	Cisco IOS XE Release 2.5	When the user requests a prefix from the prefix delegator, typically the NAS, the prefix is allocated using DHCPv6.
DHCP Accounting Attribute	Cisco IOS XE Release 3.13S	The DHCP Accounting Attribute feature allows DHCPv6 to append delegated prefix information to accounting start and stop messages.



## CHAPTER 15

# DHCPv6 Server Stateless Autoconfiguration

Hierarchical Dynamic Host Configuration Protocol for IPv6 (DHCPv6) for stateless configuration parameters allows a stateless or stateful DHCPv6 client to export configuration parameters (DHCPv6 options) to a local DHCPv6 server pool. The local DHCPv6 server can then provide the imported configuration parameters to other DHCPv6 clients.

- [Finding Feature Information, on page 215](#)
- [Information About DHCPv6 Server Stateless Autoconfiguration, on page 215](#)
- [How to Configure DHCPv6 Server Stateless Autoconfiguration, on page 217](#)
- [Configuration Examples for DHCPv6 Server Stateless Autoconfiguration, on page 220](#)
- [Additional References for DHCP Overview, on page 221](#)
- [Feature Information for DHCPv6 Server Stateless Autoconfiguration, on page 221](#)

## Finding Feature Information

Your software release may not support all the features documented in this module. For the latest caveats and feature information, see [Bug Search Tool](#) and the release notes for your platform and software release. To find information about the features documented in this module, and to see a list of the releases in which each feature is supported, see the feature information table.

Use Cisco Feature Navigator to find information about platform support and Cisco software image support. To access Cisco Feature Navigator, go to [www.cisco.com/go/cfn](http://www.cisco.com/go/cfn). An account on Cisco.com is not required.

## Information About DHCPv6 Server Stateless Autoconfiguration

### DHCPv6 Server Stateless Autoconfiguration

Hierarchical Dynamic Host Configuration Protocol for IPv6 (DHCPv6) for stateless configuration parameters allows a stateless or stateful DHCPv6 client to export configuration parameters (DHCPv6 options) to a local DHCPv6 server pool. The local DHCPv6 server can then provide the imported configuration parameters to other DHCPv6 clients.

The figure below shows a typical broadband deployment.

Figure 16: Broadband Topology

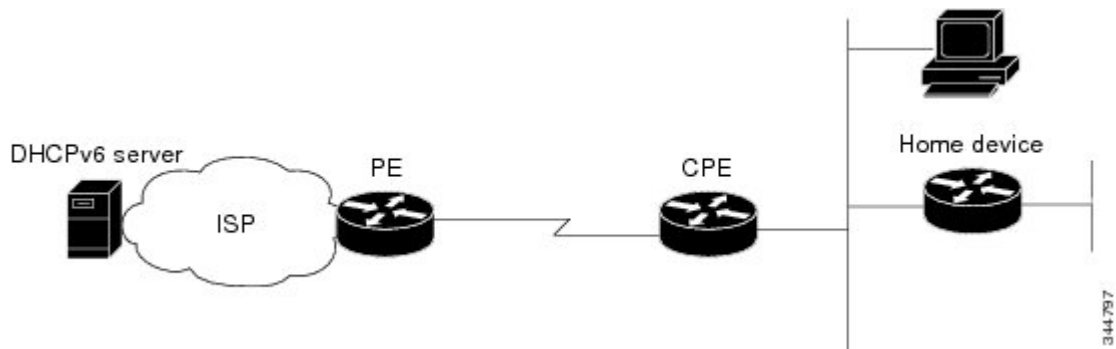

The customer premises edge (CPE) interface toward the provider edge (PE) can be a stateless or stateful DHCPv6 client. In either case, the ISP-side DHCPv6 server might provide configuration parameters such as Domain Name System (DNS) server addresses, domain names, and Simple Network Time Protocol (SNTP) servers to the DHCP client on the CPE. Such information can be specific to ISPs.

In addition to being a DHCPv6 client (for example, toward the ISP), the CPE can act as a DHCPv6 server to the home network. For example, neighbor discovery followed by a stateless or stateful DHCPv6 client can occur on the link between the CPE and the home devices. In some cases, the information to be provided to the home network is the same as that obtained from the ISP-side DHCPv6 server. Because this information can be dynamically changed, it cannot be hard-configured in the CPE's configuration. Therefore, the DHCPv6 component on the CPE allows automatic importing of configuration parameters from the DHCPv6 client to the DHCPv6 server pool.

DHCPv6 supports the options for IPv6 on the server described in the following sections.

### Information Refresh Server Option

The DHCPv6 information refresh server option can specify a maximum limit for the length of time a client should wait before refreshing the information retrieved from DHCPv6. This option is used with stateless DHCPv6 because there are no addresses or other entities with lifetimes that can tell the client when to contact the DHCPv6 server to refresh its configuration.

### NIS- and NIS+-Related Server Options

Users can configure the network information service (NIS) or NIS plus (NIS+) address or domain name of a DHCPv6 server using NIS- and NIS+-related options, and then import that information to the DHCPv6 client.

### SIP Server Options

Session Initiation Protocol (SIP) server options contain either a list of domain names or a list of IPv6 addresses that can be mapped to one or more SIP outbound proxy servers. One option carries a list of domain names, and the other option carries a list of 128-bit IPv6 addresses.

SIP is an application-layer control protocol that can establish, modify, and terminate multimedia sessions or calls. A SIP system has several logical components: user agents, proxy servers, redirect servers, and registrars. User agents can contain SIP clients; proxy servers always contain SIP clients.

### SNTP Server Option

The Simple Network Time Protocol (SNTP) server option provides a list of one or more IPv6 addresses of SNTP servers available to the client for synchronization. Clients use these SNTP servers to synchronize their

system time to that of the standard time servers. The DHCPv6 server can list the SNTP servers in decreasing order of preference, but clients treat the list of SNTP servers as an ordered list.

# How to Configure DHCPv6 Server Stateless Autoconfiguration

## Configuring the Stateless DHCPv6 Server

### SUMMARY STEPS

1. **enable**
2. **configure terminal**
3. **ipv6 dhcp pool *poolname***
4. **dns-server *ipv6-address***
5. **domain-name *domain***
6. **exit**
7. **interface *type number***
8. **ipv6 dhcp server *poolname* [**rapid-commit**] [**preference *value***] [**allow-hint**]**
9. **ipv6 nd other-config flag**
10. **end**

### DETAILED STEPS

	Command or Action	Purpose
<b>Step 1</b>	<b>enable</b>  <b>Example:</b>  Device> enable	Enables privileged EXEC mode.  • Enter your password if prompted.
<b>Step 2</b>	<b>configure terminal</b>  <b>Example:</b>  Device# configure terminal	Enters global configuration mode.
<b>Step 3</b>	<b>ipv6 dhcp pool <i>poolname</i></b>  <b>Example:</b>  Device(config)# ipv6 dhcp pool dhcp-pool	Configures a Dynamic Host Configuration Protocol for IPv6 (DHCPv6) configuration information pool and enters DHCPv6 pool configuration mode.
<b>Step 4</b>	<b>dns-server <i>ipv6-address</i></b>  <b>Example:</b>  Device(config-dhcp)# dns-server 2001:DB8:3000:3000::42	Specifies the Domain Name System (DNS) IPv6 servers available to a DHCPv6 client.

	Command or Action	Purpose
<b>Step 5</b>	<b>domain-name</b> <i>domain</i> <b>Example:</b>  Device(config-dhcp)# domain-name example.com	Configures a domain name for a DHCPv6 client.
<b>Step 6</b>	<b>exit</b> <b>Example:</b>  Device(config-dhcp)# exit	Exits DHCPv6 pool configuration mode, and returns the device to global configuration mode.
<b>Step 7</b>	<b>interface</b> <i>type number</i> <b>Example:</b>  Device(config)# interface serial 3	Specifies an interface type and number, and places the device in interface configuration mode.
<b>Step 8</b>	<b>ipv6 dhcp server</b> <i>poolname</i> [ <b>rapid-commit</b> ] [ <b>preference value</b> ] [ <b>allow-hint</b> ] <b>Example:</b>  Device(config-if)# ipv6 dhcp server dhcp-pool	Enables DHCPv6 on an interface.
<b>Step 9</b>	<b>ipv6 nd other-config flag</b> <b>Example:</b>  Device(config-if)# ipv6 nd other-config flag	Sets the “other stateful configuration” flag in IPv6 router advertisements (RAs).
<b>Step 10</b>	<b>end</b> <b>Example:</b>  Device(config-if)# end	Returns to privileged EXEC mode.

## Configuring the Stateless DHCPv6 Client

### SUMMARY STEPS

1. enable
2. configure terminal
3. interface *type number*
4. ipv6 address autoconfig [default]
5. end

### DETAILED STEPS

	Command or Action	Purpose
<b>Step 1</b>	enable	Enables privileged EXEC mode.



	Command or Action	Purpose
	<b>Example:</b> Device> enable	<ul style="list-style-type: none"> <li>• Enter your password if prompted.</li> </ul>
<b>Step 2</b>	<b>configure terminal</b> <b>Example:</b> Device# configure terminal	Enters global configuration mode.
<b>Step 3</b>	<b>interface <i>type number</i></b> <b>Example:</b> Device(config)# interface serial 3	Specifies an interface type and number, and places the device in interface configuration mode.
<b>Step 4</b>	<b>ipv6 address autoconfig [default]</b> <b>Example:</b> Device(config-if)# ipv6 address autoconfig	Enables automatic configuration of IPv6 addresses using stateless autoconfiguration on an interface and enables IPv6 processing on the interface.
<b>Step 5</b>	<b>end</b> <b>Example:</b> Device(config-if)# end	Returns to privileged EXEC mode.

## Enabling Processing of Packets with Source Routing Header Options

### SUMMARY STEPS

1. enable
2. configure terminal
3. ipv6 source-route
4. end

### DETAILED STEPS

	Command or Action	Purpose
<b>Step 1</b>	<b>enable</b> <b>Example:</b> Device> enable	Enables privileged EXEC mode. <ul style="list-style-type: none"> <li>• Enter your password if prompted.</li> </ul>
<b>Step 2</b>	<b>configure terminal</b> <b>Example:</b> Device# configure terminal	Enters global configuration mode.

	Command or Action	Purpose
<b>Step 3</b>	<b>ipv6 source-route</b> <b>Example:</b> Device(config)# ipv6 source-route	Enables processing of the IPv6 type 0 routing header.
<b>Step 4</b>	<b>end</b> <b>Example:</b> Device(config-if)# end	Returns to privileged EXEC mode.

## Configuration Examples for DHCPv6 Server Stateless Autoconfiguration

### Example: Configuring the Stateless DHCPv6 Function

The following example shows how to use the Dynamic Host Configuration Protocol for IPv6 (DHCPv6) function to configure clients with information about the name lookup system. The server is configured with a DHCP pool, which contains the name lookup information that is to be passed to clients. It does not need to contain a prefix pool. This DHCP pool is attached to the access link to customers (Ethernet 0/0) when you enter the **ipv6 dhcp server** command. The access link also has the **ipv6 nd other-config-flag** command enabled. Router advertisement (RA) messages sent from this interface inform clients that they should use DHCPv6 for “other” (for example, nonaddress) configuration information.

```

ipv6 dhcp pool dhcp-pool
 dns-server 2001:DB8:A:B::1
 dns-server 2001:DB8:3000:3000::42
 domain-name example.com
!
interface Ethernet 0/0
 description Access link down to customers
 ipv6 address 2001:DB8:1234:42::1/64
 ipv6 nd other-config-flag
 ipv6 dhcp server dhcp-pool

```

The client has no obvious DHCPv6 configuration. However, the **ipv6 address autoconfig** command on the uplink to the service provider (Ethernet 0/0) causes the following two events:

- Addresses are autoconfigured on the interface, based on prefixes in RA messages received from the server.
- If received RA messages have the “other configuration” flag set, the interface attempts to acquire the other (for example, nonaddress) configuration from any DHCPv6 servers.

## Additional References for DHCP Overview

### Related Documents

Related Topic	Document Title
Cisco IOS commands	<a href="#">Cisco IOS Master Command List, All Releases</a>
DHCP commands	<a href="#">Cisco IOS IP Addressing Services Command Reference</a>
IPv6 commands	<a href="#">Cisco IOS IPv6 Command Reference</a>
IPv6 addressing and connectivity	<i>IPv6 Configuration Guide</i>
Cisco IOS IPv6 features	<a href="#">Cisco IOS IPv6 Feature Mapping</a>

### Standards and RFCs

Standard/RFC	Title
RFC 951	<i>Bootstrap Protocol (BOOTP)</i>
RFC 1542	<i>Clarifications and Extensions for the Bootstrap Protocol</i>
RFCs for IPv6	<i>IPv6 RFCs</i>

### Technical Assistance

Description	Link
The Cisco Support and Documentation website provides online resources to download documentation, software, and tools. Use these resources to install and configure the software and to troubleshoot and resolve technical issues with Cisco products and technologies. Access to most tools on the Cisco Support and Documentation website requires a Cisco.com user ID and password.	<a href="http://www.cisco.com/cisco/web/support/index.html">http://www.cisco.com/cisco/web/support/index.html</a>

## Feature Information for DHCPv6 Server Stateless Autoconfiguration

The following table provides release information about the feature or features described in this module. This table lists only the software release that introduced support for a given feature in a given software release train. Unless noted otherwise, subsequent releases of that software release train also support that feature.

Use Cisco Feature Navigator to find information about platform support and Cisco software image support. To access Cisco Feature Navigator, go to [www.cisco.com/go/cfn](http://www.cisco.com/go/cfn). An account on Cisco.com is not required.

**Table 20: Feature Information for DHCPv6 Server Stateless Autoconfiguration**

Feature Name	Releases	Feature Information
DHCPv6 Server Stateless Autoconfiguration		<p>Hierarchical DHCPv6 for stateless configuration parameters allows a stateless or stateful DHCPv6 client to export configuration parameters (DHCPv6 options) to a local DHCPv6 server pool.</p> <p>The following commands were introduced or modified: <b>dns-server</b>, <b>domain-name</b>, <b>ipv6 address autoconfig</b>, <b>ipv6 dhcp pool</b>, <b>ipv6 dhcp server</b>, <b>ipv6 nd other-config-flag</b>, <b>ipv6 source-route</b>.</p>



## CHAPTER 16

# DHCP Server MIB

---

The DHCP Server MIB feature provides Simple Network Management Protocol (SNMP) access to and control of Cisco IOS Dynamic Host Configuration Protocol (DHCP) server software on a Cisco router by an external network management device.

- [Finding Feature Information, on page 223](#)
- [Prerequisites for the DHCP Server MIB, on page 223](#)
- [Information About the DHCP Server MIB, on page 224](#)
- [How to Enable DHCP Trap Notifications, on page 228](#)
- [Configuration Examples for the DHCP Server MIB, on page 230](#)
- [Additional References, on page 231](#)
- [Feature Information for DHCP Server MIB, on page 233](#)

## Finding Feature Information

Your software release may not support all the features documented in this module. For the latest caveats and feature information, see [Bug Search Tool](#) and the release notes for your platform and software release. To find information about the features documented in this module, and to see a list of the releases in which each feature is supported, see the feature information table.

Use Cisco Feature Navigator to find information about platform support and Cisco software image support. To access Cisco Feature Navigator, go to [www.cisco.com/go/cfn](http://www.cisco.com/go/cfn). An account on Cisco.com is not required.

## Prerequisites for the DHCP Server MIB

SNMP must be enabled on the router before DHCP server trap notifications can be configured.

# Information About the DHCP Server MIB

## SNMP Overview

SNMP is an application-layer protocol that provides a message format for communication between SNMP managers and agents. SNMP provides a standardized framework and a common language that is used for monitoring and managing devices in a network.

SNMP defines two main types of entities: managers and agents. The SNMP manager is a system that controls and monitors the activities of network hosts using SNMP. The agent is the software component within a remote networking device that maintains the data and reports this data, as needed, to the manager. The manager and agent share a Management Information Base (MIB) that defines the information that the agent can make available to the manager.

An important feature of SNMP is the capability to generate unsolicited notifications from an SNMP agent. These trap notifications are messages alerting the SNMP manager to conditions on the network. Traps are considered an agent-to-manager function and a request for confirmation of receipt from the SNMP manager is not required.

## DHCP Server Trap Notifications

DHCP server trap notifications are sent to the SNMP manager for the following events:

- Address utilization for a subnet has risen above or fallen below a configurable threshold.
- Address utilization for an address pool has risen above or fallen below a configurable threshold.
- A lease limit violation is detected. The lease limit configuration allows you to control the number of subscribers per interface.
- The DHCP server has started or stopped.
- A duplicate IP address is detected.

The DHCP Server MIB feature does not send the same type of trap notification back-to-back for the same threshold event. For example, if the low threshold value for available free addresses becomes equal to or less than the configured value, a free address low event trap notification on the subnet or pool is generated. This same trap notification will not be resent until the value for the available free addresses has exceeded the value of the free high threshold and vice versa. This threshold control mechanism applies to all trap notifications concerning thresholds in addition to the trap notifications for the DHCP server start and stop time and the lease limit violation. The duplicate IP address trap notification is not subject to this threshold control mechanism.

## Tables and Objects in the DHCP Server MIB

The DHCP Server MIB consists of the following tables and objects. The first character of a row in the table begins with “c” (Cisco) and is mapped to the object defined in the IETF draft RFC, *Dynamic Host Configuration Protocol for IPv4 Server MIB*. If the information is not currently available in Cisco IOS software, the value in the second column is displayed as 0 (zero).

- cDhcpv4SrvSystemsObjects (see Table 7)--System description and object IDs

- cBootpHCCounterObjects (see Table 8)--BOOTP counter information
- cDhcpv4HCCounterObjects (see Table 9)--DHCPv4 counter information
- cDhcpv4ServerSharedNetTable (see Table 10)--DHCP address pool information
- cDhcpv4ServerSubnetTable (see Table 11)--Additional DHCP address pool subnet information including secondary subnet information
- cDhcpv4SrvExtSubnetTable (see Table 12)--Additional DHCP address pool subnet information
- cDhcpv4ServerNotifyObjectsGroup (see Table 13)--This objects group is used by the cDhcpv4ServerNotificationsGroup notifications group.
- cDhcpv4ServerNotificationsGroup (see Table 14)--This notifications group consists of all traps defined in the Cisco IOS DHCP server.
- cDhcpv4SrvExtNotifyGroup (see Table 15)--This notifications group consists of all traps not defined in the draft DHCPv4 Server MIB RFC.

**Table 21: cDhcpv4SrvSystemsObjects and Descriptions**

Name	Description
cDhcpv4SrvSystemDescr	Contains a textual description of the server (full name and version identification).
cDhcpv4SrvSystemObjectID	Cisco experiment node for the DHCP Server MIB. For example, 1.3.6.1.4.1.9.10.102...

**Table 22: cBootpHCCounterObjects and Descriptions**

Name	Description
cBootpHCCountRequests	The number of packets received that do contain a BOOTREQUEST message type in the first octet.
cBootpHCCountInvalids	0
cBootpHCCountReplies	The number of packets received that contain a BOOTREPLY message type in the first octet.
cBootpHCCountDroppedUnknown Clients	0
cBootpHCCountDroppedNotServingSubnet	0

**Table 23: cDhcpv4HCCounterObjects and Descriptions**

Name	Description
cDhcpv4HCCountDiscovers	The number of DHCPDISCOVER packets received.
cDhcpv4HCCountOffers	The number of DHCP OFFER packets sent.
cDhcpv4HCCountRequests	The number of DHCPREQUEST packets sent.

Name	Description
cDhcpv4HCCountDeclines	The number of DHCPDECLINE packets sent.
cDhcpv4HCCountAcks	The number of DHCPACK packets sent.
cDhcpv4HCCountNaks	The number of DHCPNACK packets sent.
cDhcpv4HCCountReleases	The number of DHCPRELEASE packets sent.
cDhcpv4HCCountInforms	The number of DHCPINFORM packets sent.
cDhcpv4HCCountForcedRenews	0
cDhcpv4HCCountInvalids	The number of DHCP packets received whose DHCP message type is not understood or handled by the DHCP server.
cDhcpv4HCCountDropUnknownClient	0
cDhcpv4HCCountDropNotServingSubnet	0

**Table 24: cDhcpv4ServerSharedNetTable and Descriptions**

Name	Description
cDhcpv4ServerSharedNetName	The DHCP address pool name.
cDhcpv4ServerSharedNetFreeAddr LowThreshold	This entry value corresponds to the <b>utilization mark high</b> command in DHCP pool configuration mode multiplied by the total pool addresses then divided by 100.
cDhcpv4ServerSharedNetFreeAddrHighThreshold	This entry value corresponds to the <b>utilization mark low</b> command in DHCP pool configuration mode multiplied by the total subnet addresses then divided by 100.
cDhcpv4ServerSharedNetFree Addresses	The number of IPv4 addresses that are available within this shared network.
cDhcpv4ServerSharedNetReserved Addresses	The number of IP addresses that are reserved for the pool (not available for assignment). This entry corresponds to the <b>ip dhcp excluded-address</b> global configuration command. The value is zero if no excluded addresses are defined for the pool.
cDhcpv4ServerSharedNetTotal Addresses	The number of IP addresses that are available within this shared network.

**Table 25: cDhcpv4ServerSubnetTable and Descriptions**

Name	Description
cDhcpv4ServerSubnetAddress	The IP address of the subnet entry in the table.



Name	Description
cDhcpv4ServerSubnetMask	The subnet mask of the subnet.
cDhcpv4ServerSubnetSharedNetworkName	The DHCP address pool name to which the subnet belongs.
cDhcpv4ServerSubnetFreeAddrLowThreshold	This entry value corresponds to the <b>override utilization high</b> command in DHCP pool secondary subnet configuration mode multiplied by the total subnet addresses then divided by 100.
cDhcpv4ServerSubnetFreeAddrHighThreshold	This entry value corresponds to the <b>override utilization low</b> command in DHCP pool secondary subnet configuration mode multiplied by the total subnet addresses then divided by 100.
cDhcpv4ServerSubnetFree Addresses	The number of free IP addresses that are available in the subnet.

**Table 26: cDhcpv4SrvExtSubnetTable and Descriptions**

Name	Description
cDhcpv4ServerDefaultRouterAddress	The entry corresponds to the <b>override default-router</b> command in DHCP pool secondary subnet configuration mode.
cDhcpv4ServerSubnetStartAddress	The first subnet IP address.
cDhcpv4ServerSubnetEndAddress	The last subnet IP address.

**Table 27: cDhcpv4ServerNotifyObjectsGroups and Descriptions**

Name	Description
cDhcpv4ServerNotifyDuplicateIpAddr	The IP address is found to be a duplicate. Duplicates are detected by servers who send a PING before offering an IP address lease or by a client sending a gratuitous ARP message reported through a DHCPDECLINE message.
cDhcpv4ServerNotifyDuplicateMac	The offending MAC address that caused a duplicate IPv4 address to be detected, if captured by the server, otherwise set to 00-00-00-00-00-00.
cDhcpv4ServerNotifyClientOrServerDetected	This object is set by the server to client if the client used DHCPDECLINE to mark the offered address as in use, or to server if the server discovered that address was in use by a client before offering it.
cDhcpv4ServerNotifyServerStart	The date and time when the server began operation, which is controlled by the <b>service dhcp</b> command.
cDhcpv4ServerNotifyServerStop	The date and time when the server ceased operation, which is controlled by <b>no service dhcp</b> command.

Table 28: cDhcpv4ServerNotificationsGroup and Descriptions

Name	Description
cDhcpv4ServerFreeAddressLow	This notification signifies that the number of available IP addresses for a DHCP address pool has fallen below the defined low threshold. This notification corresponds to the <b>snmp-server enable traps dhcp</b> global configuration command.
cDhcpv4ServerFreeAddressHigh	This notification signifies that the number of available IP addresses for a DHCP address pool has risen above the defined high threshold. This notification corresponds to the <b>snmp-server enable traps dhcp</b> global configuration command.
cDhcpv4ServerStartTime	This notification signifies that the server has started. This notification corresponds to the <b>service dhcp</b> and <b>snmp-server enable traps dhcp time</b> global configuration commands.
cDhcpv4ServerStopTime	This notification signifies that the server has stopped normally. This notification corresponds to the <b>no service dhcp</b> and <b>snmp-server enable traps dhcp time</b> global configuration commands.
cDhcpv4ServerDuplicateAddress	This notification signifies that a duplicate IP address has been detected. This notification corresponds to the <b>snmp-server enable traps dhcp duplicate</b> global configuration command.

Table 29: cDhcpv4SrvNotifyGroup and Descriptions

Name (not in the RFC draft)	Description
cDhcpv4ServerIfLeaseLimitExceeded	This notification signifies that a per interface lease limit is exceeded. This notification corresponds to the <b>snmp-server enable traps dhcp interface</b> global configuration command.
cDhcpv4ServerSubnetFreeAddressLow	This notification signifies that the number of available IP addresses for a subnet has fallen below the defined low threshold. This notification corresponds to the <b>snmp-server enable traps dhcp subnet</b> global configuration command.
cDhcpv4ServerSubnetFreeAddressHigh	This notification signifies that the number of available IPv4 addresses for a subnet has risen above the defined high threshold. This notification corresponds to the <b>snmp-server enable traps dhcp subnet</b> global configuration command.

## How to Enable DHCP Trap Notifications

### Configuring the Router to Send SNMP Trap Notifications About DHCP

DHCP trap notifications are disabled by default. The trap notification is disabled if the corresponding trap configuration is not enabled.

## SUMMARY STEPS

1. **enable**
2. **configure terminal**
3. **snmp-server enable traps dhcp duplicate ] [interface] [pool] [subnet] [time**
4. **end**

## DETAILED STEPS

	Command or Action	Purpose
Step 1	<b>enable</b> <b>Example:</b> Router> enable	Enables privileged EXEC mode. <ul style="list-style-type: none"> <li>• Enter your password if prompted.</li> </ul>
Step 2	<b>configure terminal</b> <b>Example:</b> Router# configure terminal	Enters global configuration mode.
Step 3	<b>snmp-server enable traps dhcp duplicate ] [interface] [pool] [subnet] [time</b> <b>Example:</b> Router(config)# snmp-server enable traps dhcp	Enables the sending of DHCP SNMP trap notifications. <ul style="list-style-type: none"> <li>• <b>duplicate</b> --Sends notification about duplicate IP addresses.</li> <li>• <b>interface</b> --Sends notification that a per interface lease limit is exceeded.</li> <li>• <b>pool</b> --Sends notification when address utilization for an address pool has risen above or fallen below a configurable threshold.</li> <li>• <b>subnet</b> --Sends notification when address utilization for a subnet has risen above or fallen below a configurable threshold.</li> <li>• <b>time</b> --Sends notification that the DHCP server has started or stopped.</li> <li>• If you specify the <b>snmp-server enables traps dhcp</b> command without any of the optional keywords, all DHCP trap notifications are enabled.</li> </ul>
Step 4	<b>end</b> <b>Example:</b> Router(config)# end	Returns the router to privileged EXEC mode.

## Troubleshooting Tips

If you are using secondary IP addresses under a single loopback interface and using secondary subnets under a DHCP pool, use one DHCP pool to configure networks for all the secondary subnets instead of using one

pool per secondary subnet. The **network** *network-number* [*mask* | */prefix-length*] [**secondary**] command must be configured under a single DHCP address pool rather than multiple DHCP address pools.

The following is the correct configuration:

```
!
ip dhcp pool dhcp_1
 network 172.16.1.0 255.255.255.0
 network 172.16.2.0 255.255.255.0 secondary
 network 172.16.3.0 255.255.255.0 secondary
 network 172.16.4.0 255.255.255.0 secondary
!
interface Loopback111
 ip address 172.16.1.1 255.255.255.255 secondary
 ip address 172.16.2.1 255.255.255.255 secondary
 ip address 172.16.3.1 255.255.255.255 secondary
 ip address 172.16.4.1 255.255.255.255 secondary
```

The following is the incorrect configuration:

```
!
ip dhcp pool dhcp_1
 network 172.16.1.0 255.255.255.0
 lease 1 20 30
 accounting default
!
ip dhcp pool dhcp_2
 network 172.16.2.0 255.255.255.0
 lease 1 20 30
 accounting default
!
ip dhcp pool dhcp_3
 network 172.16.3.0 255.255.255.0
 lease 1 20 30
 accounting default
!
ip dhcp pool dhcp_4
 network 172.16.4.0 255.255.255.0
 lease 1 20 30
 accounting default
!
interface Loopback111
 ip address 172.16.1.1 255.255.255.255 secondary
 ip address 172.16.2.1 255.255.255.255 secondary
 ip address 172.16.3.1 255.255.255.255 secondary
 ip address 172.16.4.1 255.255.255.255 secondary
```

## Configuration Examples for the DHCP Server MIB

### DHCP Server MIB--Secondary Subnet Trap Example

The following example configures 192.0.2.0/24 as the subnetwork number and mask of the DHCP pool named pool2 and then adds the DHCP pool secondary subnet specified by the subnet number and mask 192.0.4.0/30. The IP addresses in pool2 consist of two disjoint subnets: the addresses from 192.0.2.1 to 192.0.2.254 and the addresses from 192.0.4.1 to 192.0.4.2.

The address pool utilization mark, configured at the global level, will be overridden at the secondary subnet level. A trap is sent to the SNMP manager if the subnet size of the secondary subnet exceeds or goes below the level specified by the **override utilization** commands.

The **utilization mark {high|low} log** command enables a system message to be generated for a DHCP address pool or secondary subnet when the utilization exceeds the configured high utilization threshold or falls below the configured low utilization threshold.

```
!
ip dhcp pool pool2
  utilization mark high 80 log
  utilization mark low 70 log
  network 192.0.2.0 255.255.255.0
  network 192.0.4.0 255.255.255.252 secondary
  override utilization high 40
  override utilization low 30
!
snmp-server enable traps dhcp subnet
```

## DHCP Server MIB--Address Pool Trap Example

In the following example, if the address utilization exceeds the high threshold or drops below the low threshold, an SNMP trap will be sent to the SNMP manager and a system message will be generated.

```
ip dhcp pool pool3
  utilization mark high 80 log
  utilization mark low 70 log
!
snmp-server enable traps dhcp pool
```

## DHCP Server MIB--Lease Limit Violation Trap Example

In the following example, four DHCP clients are allowed to receive IP addresses. If a fifth client tries to obtain an IP address, the DHCPDISCOVER messages will not be forwarded to the DHCP server and a trap will be sent to the SNMP manager.

```
ip dhcp limit lease log
interface Serial 0/0
  ip dhcp limit lease 4
  exit
snmp-server enable traps dhcp interface
```

## Additional References

The following sections provide references related to the DHCP Server MIB feature.

### Related Documents

Related Topic	Document Title
SNMP configuration tasks	“Configuring SNMP Support” module

Related Topic	Document Title
DHCP commands: complete command syntax, command mode, command history, defaults, usage guidelines, and examples	<i>Cisco IOS IP Addressing Services Command Reference</i>
DHCP server configuration tasks including subnet utilization tasks	“Configuring the Cisco IOS DHCP Server” module
DHCP per interface lease limit functionality	“Configuring DHCP Services for Accounting and Security” module
DHCP ODAP tasks including address pool utilization tasks	“Configuring the DHCP Server On-Demand Address Pool Manager” module

### Standards

Standard	Title
No new or modified standards are supported by this feature.	--

### MIBs

MIB	MIBs Link
<ul style="list-style-type: none"> <li>• CISCO-IETF-DHCP-SERVER-MIB</li> <li>• CISCO-IETF-DHCP-SERVER-EXT-MIB</li> </ul>	<p>To locate and download MIBs for selected platforms, Cisco IOS releases, and feature sets, use Cisco MIB Locator found at the following URL:</p> <p><a href="http://www.cisco.com/go/mibs">http://www.cisco.com/go/mibs</a></p>

### RFCs

RFC	Title
Draft RFC: draft-ietf-dhc-server-mib-10.txt	<a href="#">Dynamic Host Configuration Protocol for IPv4 (DHCPv4) Server MIB</a>

### Technical Assistance

Description	Link
The Cisco Support and Documentation website provides online resources to download documentation, software, and tools. Use these resources to install and configure the software and to troubleshoot and resolve technical issues with Cisco products and technologies. Access to most tools on the Cisco Support and Documentation website requires a Cisco.com user ID and password.	<a href="http://www.cisco.com/cisco/web/support/index.html">http://www.cisco.com/cisco/web/support/index.html</a>

## Feature Information for DHCP Server MIB

The following table provides release information about the feature or features described in this module. This table lists only the software release that introduced support for a given feature in a given software release train. Unless noted otherwise, subsequent releases of that software release train also support that feature.

Use Cisco Feature Navigator to find information about platform support and Cisco software image support. To access Cisco Feature Navigator, go to [www.cisco.com/go/cfn](http://www.cisco.com/go/cfn). An account on Cisco.com is not required.

**Table 30: Feature Information for DHCP Server MIB**

Feature Name	Releases	Feature Information
DHCP Server MIB		<p>The DHCP Server MIB feature provides SNMP access to and control of Cisco IOS DHCP server software on a Cisco router by an external network management device.</p> <p>The following commands were introduced by this feature: <b>snmp-server enable traps dhcp</b> and <b>debug ip dhcp server snmp</b>.</p>

