



ISSU and SSO--DHCP High Availability Features

Cisco IOS XE Release 2.1 and 2.3 introduce the following series of Dynamic Host Configuration Protocol (DHCP) High Availability features:

- ISSU--DHCP Server
- SSO--DHCP Server
- ISSU--DHCP Relay on Unnumbered Interface
- SSO--DHCP Relay on Unnumbered Interface
- ISSU--DHCP Proxy Client
- SSO--DHCP Proxy Client
- ISSU--DHCP ODAP Client and Server
- SSO--DHCP ODAP Client and Server

These features are enabled by default when the redundancy mode of operation is set to Stateful Switchover (SSO).

- [Finding Feature Information, page 2](#)
- [Prerequisites for DHCP High Availability, page 2](#)
- [Restrictions for DHCP High Availability, page 2](#)
- [Information About DHCP High Availability, page 2](#)
- [How to Configure DHCP High Availability, page 6](#)
- [Configuration Examples for DHCP High Availability, page 6](#)
- [Additional References, page 6](#)
- [Feature Information for DHCP High Availability Features, page 8](#)
- [Glossary, page 9](#)

Finding Feature Information

Your software release may not support all the features documented in this module. For the latest caveats and feature information, see [Bug Search Tool](#) and the release notes for your platform and software release. To find information about the features documented in this module, and to see a list of the releases in which each feature is supported, see the feature information table.

Use Cisco Feature Navigator to find information about platform support and Cisco software image support. To access Cisco Feature Navigator, go to www.cisco.com/go/cfn. An account on Cisco.com is not required.

Prerequisites for DHCP High Availability

- The Cisco IOS XE In-Service Software Upgrade (ISSU) process must be configured and working properly. See the “Cisco IOS XE In-Service Software Upgrade Process” feature module for more information.
- Stateful Switchover (SSO) must be configured and working properly. See the “Stateful Switchover” feature module for more information.
- Nonstop Forwarding (NSF) must be configured and working properly. See the “Cisco Nonstop Forwarding” feature module for more information.

Restrictions for DHCP High Availability

The DHCP high availability features do not support DHCP accounting or DHCP authorized Address Resolution Protocol (ARP).

Information About DHCP High Availability

ISSU

The ISSU process allows Cisco IOS XE software to be updated or otherwise modified while packet forwarding continues. In most networks, planned software upgrades are a significant cause of downtime. ISSU allows Cisco IOS XE software to be modified while packet forwarding continues, which increases network availability and reduces downtime caused by planned software upgrades.

SSO

SSO refers to the implementation of Cisco IOS XE software that allows applications and features to maintain a defined state between an active and standby Route Processor (RP).

In specific Cisco networking devices that support dual RPs, SSO takes advantage of RP redundancy to increase network availability. The SSO feature takes advantage of RP redundancy by establishing one of the RPs as the active RP while the other RP is designated as the standby RP, and then synchronizing critical state

information between them. Following an initial synchronization between the two processors, SSO dynamically maintains RP state information between them.

A switchover from the active to the standby processor occurs when the active RP fails, is removed from the networking device, or is manually taken down for maintenance.

ISSU and SSO--DHCP Server

The DHCP server that is ISSU and SSO aware is able to detect when a router is failing over to the standby RP and preserve the DHCP lease across a switchover event.

Each DHCP binding is synchronized and re-created from the active RP to the standby RP upon lease commit. The figure below illustrates this process. The lease extension and release are also synchronized to the standby RP.

Figure 1: DHCP Server Maintaining States Between the Active and Standby Route Processor

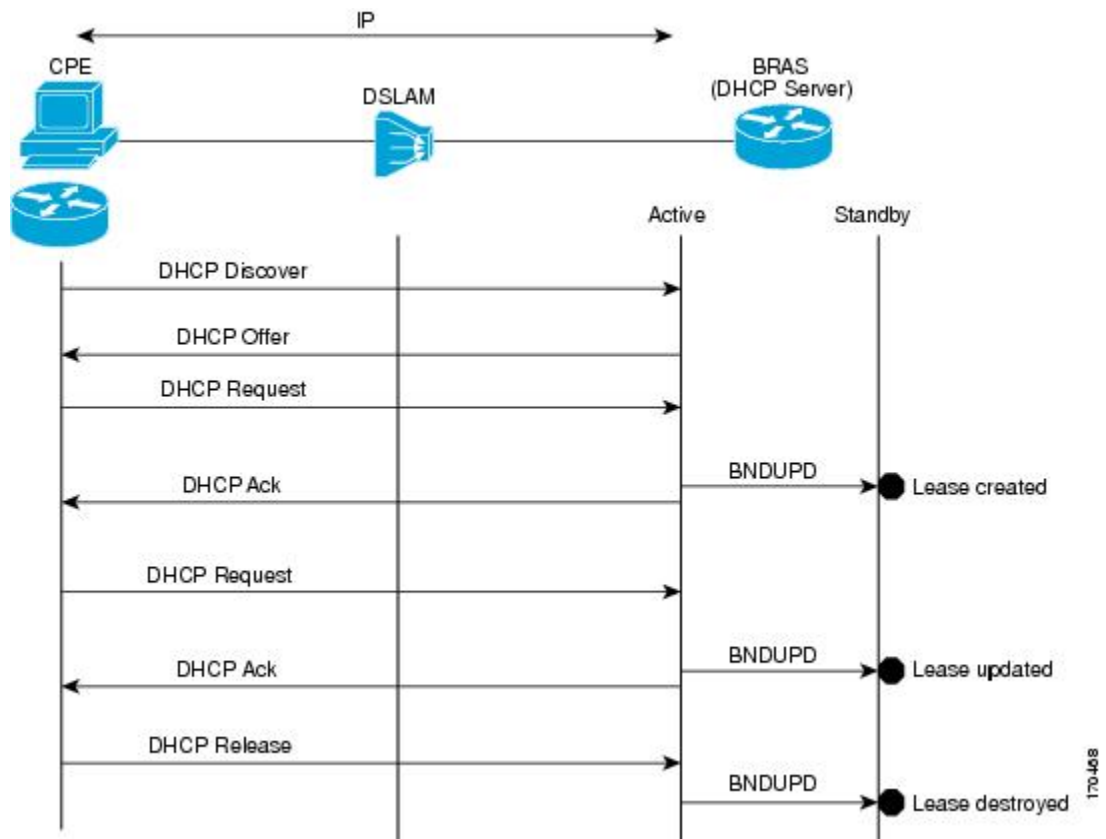

ISSU and SSO--DHCP Relay on Unnumbered Interface

The DHCP relay agent supports the use of unnumbered interfaces. For DHCP clients connected through the unnumbered interfaces, the DHCP relay agent automatically adds a static host route once the DHCP client obtains an address, specifying the unnumbered interface as the outbound interface. The route is automatically removed once the lease time expires or when the client releases the address.

The `ip helper-address` interface configuration command must be configured on the unnumbered interface to enable the Cisco IOS XE DHCP relay agent on unnumbered interfaces. See the “Configuring the Cisco IOS XE DHCP Relay Agent” configuration module for more information.

The ISSU and SSO DHCP relay on unnumbered interface functionality adds high availability support for host routes to clients connected through unnumbered interfaces. The DHCP relay agent can now detect when a router is failing over to the standby RP and keep the states related to unnumbered interfaces. The figure below illustrates the process.

Figure 2: DHCP Maintaining States with an IP Unnumbered Interface

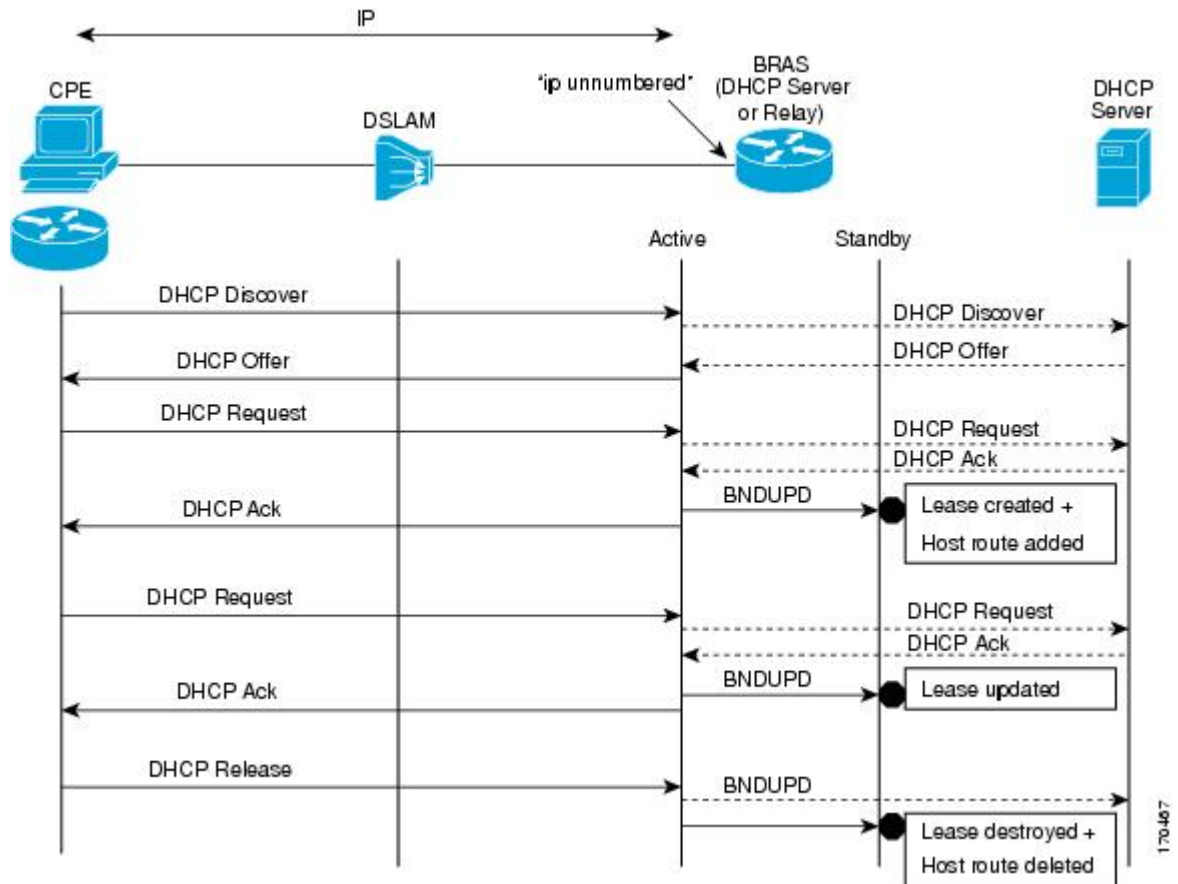

ISSU and SSO--DHCP Proxy Client

The DHCP proxy client enables the router to obtain a lease for configuration parameters from a DHCP server for a remote Point-to-Point Protocol (PPP) client. The DHCP proxy client that is ISSU and SSO aware is able

to request a lease from the DHCP server and the state of the lease is synchronized between the active and standby RP. The figure below illustrates the process.

Figure 3: DHCP Proxy Client Lease Synchronization

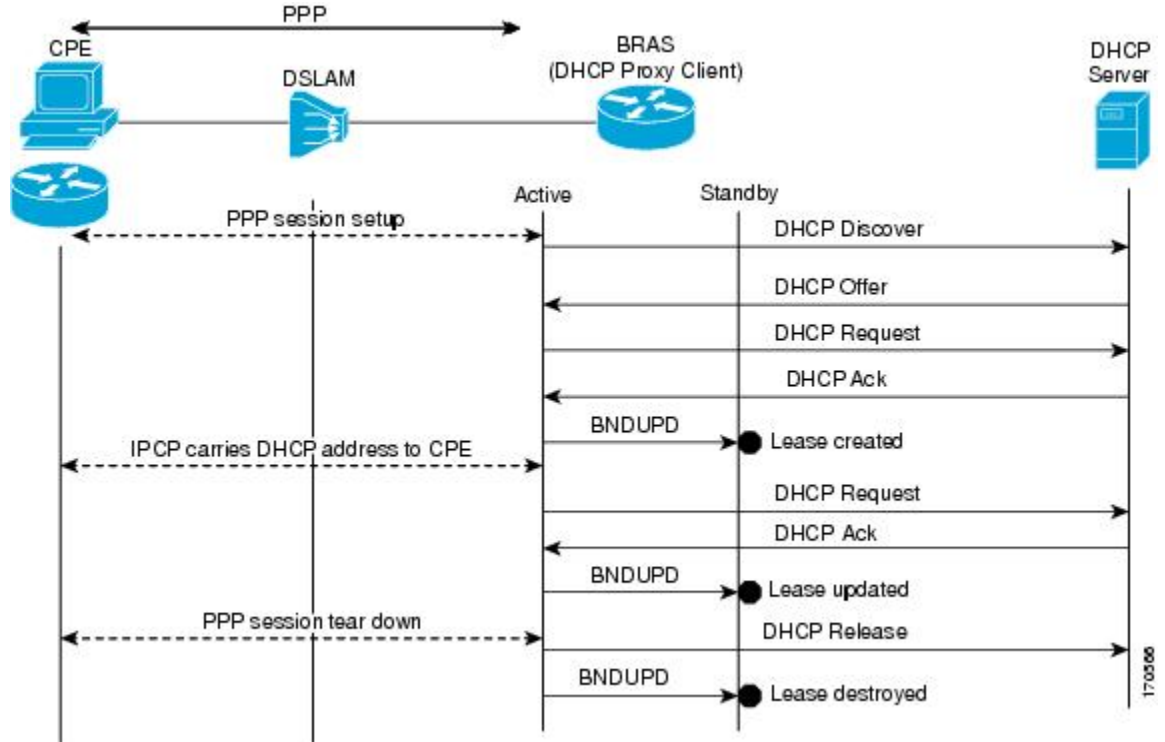

ISSU and SSO--DHCP ODAP Client and Server

The DHCP on-demand address pool (ODAP) client that is ISSU and SSO aware can request a lease for a subnet from the DHCP ODAP server. After the DHCP ODAP server allocates the subnet to the client, the state of the lease is synchronized between the active and standby RP through binding updates. Following a

switchover event, the DHCP ODAP client can continue to allocate IP addresses from the same subnets and also continue to renew the subnets from the DHCP ODAP server. The figure below illustrates the process.

Figure 4: ODAP Subnet Lease Synchronization

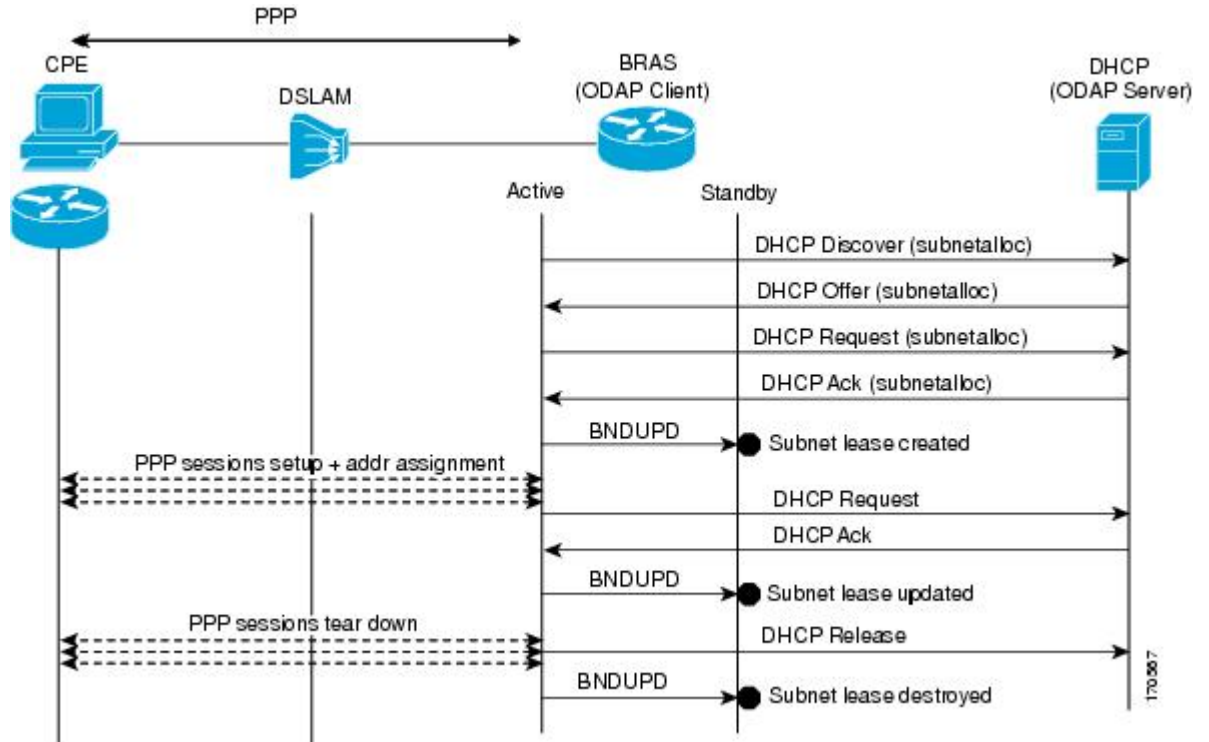

How to Configure DHCP High Availability

There are no configuration tasks. The DHCP high availability features are enabled by default when the redundancy mode of operation is set to SSO.

Configuration Examples for DHCP High Availability

There are no configuration examples for DHCP high availability features.

Additional References

The following sections provide references related to DHCP high availability features.

Related Documents

Related Topic	Document Title
DHCP commands: complete command syntax, command modes, command history, defaults, usage guidelines, and examples	<i>Cisco IOS IP Addressing Services Command Reference</i>
DHCP conceptual and configuration information	<i>Cisco IOS XE IP Addressing Services Configuration Guide</i>
In-Service Software Upgrade process conceptual and configuration information	"Cisco IOS XE In Service Software Upgrade Process" module
Nonstop Forwarding conceptual and configuration information	"Cisco Nonstop Forwarding" module
Stateful switchover conceptual and configuration information	"Stateful Switchover" module

Standards

Standard	Title
No new or modified standards are supported by this feature.	--

MIBs

MIB	MIBs Link
No new or modified MIBs are supported by this feature.	To locate and download MIBs for selected platforms, Cisco IOS XE software releases, and feature sets, use Cisco MIB Locator found at the following URL: http://www.cisco.com/go/mibs

RFCs

RFC	Title
No new or modified RFCs are supported by this feature.	--

Technical Assistance

Description	Link
<p>The Cisco Support website provides extensive online resources, including documentation and tools for troubleshooting and resolving technical issues with Cisco products and technologies.</p> <p>To receive security and technical information about your products, you can subscribe to various services, such as the Product Alert Tool (accessed from Field Notices), the Cisco Technical Services Newsletter, and Really Simple Syndication (RSS) Feeds.</p> <p>Access to most tools on the Cisco Support website requires a Cisco.com user ID and password.</p>	<p>http://www.cisco.com/techsupport</p>

Feature Information for DHCP High Availability Features

The following table provides release information about the feature or features described in this module. This table lists only the software release that introduced support for a given feature in a given software release train. Unless noted otherwise, subsequent releases of that software release train also support that feature.

Use Cisco Feature Navigator to find information about platform support and Cisco software image support. To access Cisco Feature Navigator, go to www.cisco.com/go/cfn. An account on Cisco.com is not required.

Table 1: Feature Information for DHCP High Availability Features

Feature Name	Releases	Feature Information
ISSU--DHCP Server	Cisco IOS XE Release 2.1	The DHCP server has been enhanced to support ISSU.
SSO--DHCP Server	Cisco IOS XE Release 2.1	The DHCP server has been enhanced to support SSO.
ISSU--DHCP Relay on Unnumbered Interface	Cisco IOS XE Release 2.3	The DHCP relay on unnumbered interface has been enhanced to support ISSU.
SSO--DHCP Relay on Unnumbered Interface	Cisco IOS XE Release 2.1	The DHCP relay on unnumbered interface has been enhanced to support SSO.
ISSU--DHCP Proxy Client	Cisco IOS XE Release 2.3	The DHCP proxy client has been enhanced to support ISSU.
SSO--DHCP Proxy Client	Cisco IOS XE Release 2.3	The DHCP proxy client has been enhanced to support SSO.

Feature Name	Releases	Feature Information
ISSU--DHCP ODAP Client and Server	Cisco IOS XE Release 2.3	The DHCP ODAP client and server have been enhanced to support ISSU.
SSO--DHCP ODAP Client and Server	Cisco IOS XE Release 2.3	The DHCP ODAP client and server have been enhanced to support SSO.

Glossary

CPE --customer premises equipment. Terminating equipment, such as terminals, telephones, and modems, supplied by the service provider, installed at customer sites, and connected to the network.

DSLAM --digital subscriber line access multiplexer. A device that connects many digital subscriber lines to a network by multiplexing the DSL traffic onto one or more network trunk lines.

ISSU --In Service Software Upgrade. ISSU is a process that allows Cisco IOS software to be updated or otherwise modified while packet forwarding continues.

ODAP --On-Demand Address Pool. ODAPs enable pools of IP addresses to be dynamically increased or reduced in size depending on the address utilization level. Once configured, the ODAP is populated with one or more subnets leased from a source server and is ready to serve address requests from DHCP clients or from PPP sessions.

RP --Route Processor. A generic term for the centralized control unit in a chassis.

SSO --Stateful Switchover. SSO refers to the implementation of Cisco IOS software that allows applications and features to maintain a defined state between an active and standby RP. When a switching occurs, forwarding and sessions are maintained. SSO makes an RP failure undetectable to the network.

