



Ethernet Virtual Connections Configuration

An Ethernet Virtual Connection (EVC) is defined by the Metro-Ethernet Forum (MEF) as an association between two or more user network interfaces that identifies a point-to-point or multipoint-to-multipoint path within the service provider network. An EVC is a conceptual *service pipe* within the service provider network. A *bridge domain* is a local broadcast domain that is VLAN-ID-agnostic. An Ethernet flow point (EFP) service instance is a logical interface that connects a bridge domain to a physical port or to an EtherChannel group.

An EVC broadcast domain is determined by a bridge domain and the EFPs that are connected to it. You can connect multiple EFPs to the same bridge domain on the same physical interface, and each EFP can have its own matching criteria and rewrite operation. An incoming frame is matched against EFP matching criteria on the interface, learned on the matching EFP, and forwarded to one or more EFPs in the bridge domain. If there are no matching EFPs, the frame is dropped.

You can use EFPs to configure VLAN translation. For example, if there are two EFPs egressing the same interface, each EFP can have a different VLAN rewrite operation, which is more flexible than the traditional switchport VLAN translation model.

This document describes how to configure EVC features.

For detailed information about the commands, see:

- Cisco IOS XE 3S Carrier Ethernet Command Reference:
http://www.cisco.com/en/US/docs/ios/cether/command/reference/ce_book.html
- Master Command Index for Cisco IOS XE Release 3S:
http://www.cisco.com/en/US/docs/ios/mcl/allreleasemcl/all_book.html
- [Supported EVC Features, on page 1](#)
- [Limitations, on page 3](#)
- [Ethernet Virtual Connections, on page 4](#)
- [Configuring EFPs, on page 14](#)
- [Configuration Examples, on page 19](#)
- [Configuring Other Features on EFPs, on page 23](#)
- [Configuring a Static MAC Address, on page 37](#)

Supported EVC Features

- Service instance—you create, delete, and modify EFP service instances on Ethernet interfaces.
- Encapsulation—you can map traffic to EFPs based on:

- 802.1Q VLANs (a single VLAN or a list or range of VLANs)
- 802.1Q tunneling (QinQ) VLANs (a single outer VLAN and a list or range of inner VLANs)
- Double-tagged frames mapped to EVC based on C-tags (wildcard S-Tags)
- Bridge domains—you can configure EFPs as members of a bridge domain (up to 64 EFPs per bridge domain for bridge domain with BDIs.).
- Rewrite (VLAN translation)
 - Pop symmetric
 - pop 1** removes the outermost tag
 - pop 2** removes the two outermost tags
 - pop symmetric** adds a tag (or 2 tags for **pop 2 symmetric**) on egress for a *push* operation
 - Ingress push—The **rewrite ingress tag push dot1q vlan-id symmetric** command adds a tag to an ingress packet
 - QinQ with rewrite

rewrite ingress tag push is supported on QoS with CoS Marking for EVCs on RSP2 module.



Note Ingress push on Qos on for EVC is *not* supported on RSP1 module.



Note EVC push is also supported on 802.1ad.

- EVC forwarding
- MAC address learning and aging
- EVCs on EtherChannels
- Hairpinning
- Split horizon
- Layer 2 protocol tunneling and QinQ
- Bridging between EFPs
- MSTP (MST on EVC bridge domain)
- EFP statistics (packets and bytes)
- QoS aware EVC/EFP per service instance
- Static MAC Addresses

These Layer 2 port-based features can run with EVC configured on the port:

- LACP

- CDP
- MSTP
- EVC egress filtering

Limitations

The following limitations apply when configuring EVC features:

- Egress filtering on ASIC results in packets loss for VLAN ranges below 5 and also the comma-separated VLANs are forwarded only with packets having the first VLAN. To avoid packet drops, ensure to configure a VLAN range value greater than 5.
- Encapsulation with untag and dot1q cannot be configured on single EVC on the RSP3 module.
- You can create a maximum of 32 VLAN ranges or VLAN lists, of 5 VLANs and above on each ASIC in the RSP3 module. If the VLAN range is configured on a port-channel, then it applies to both ASICs.
- Translate operations are *not* supported.
- You can create a maximum of 8000 EVCs per interface. For more information, see section 16K EFP Support in the [Quality of Service Configuration Guidelines, Cisco IOS XE Fuji 16.7.x \(Cisco ASR 900 Series\)](#).
- You can create a maximum of 256 EFPs per bridge-domain.
- A delay of 30-40 ms is observed while adding or removing the VLAN ID on any EFP for existing traffic on the RSP3 module.
- The **no mac address-table learning bridge-domain** *bridge-id* global configuration command is *not* currently supported.
- Only dot1q encapsulation is supported on trunk EFPs.
- Priority tagging and encapsulation untagged are *not* supported under the same EFP on the RSP3 module.
- BDI statistics is supported on the RSP3 module starting Cisco IOS XE Fuji 16.9.3 Release.
- On the RSP3 module, the Trunk EFP does not drop unallowed VLANs, when any other EFP does not exist to filter the VLANs. The traffic for those VLANs is bridged across to the corresponding BD, if it exists.
- Ingress mapping of Differentiated Services Code Point (DSCP) or Class of Service (CoS) to the C-CoS or S-CoS is supported.
- Egress classification and queuing is based on DSCP or CoS.
- Ethertype encapsulation and CoS value encapsulation are *not* supported on the RSP3 module.
- For layer 2 VPN and VPLS, when one end is configured as "encapsulation default" and other end is configured without any rewrite options, the packets drop and these dropped packets are considered as "Output Drops". This is an expected behavior.

This behavior is applicable to Cisco RSP2 Module. This behavior is not seen in Cisco RSP1 and Cisco RSP3 Modules.

- Overlapping of VLAN range is not supported on EFPs configured on the same interface on the RSP3 module.
- If a Layer3 bridge domain interface (BDI) is associated with a bridge domain, then 64 EFPs are supported on that bridge domain across a single or multiple interfaces on the RSP3 module.
- Remote MEPs are not learnt when SH group 1 and SH group 2 are configured in the access EVC BD.
- TCAM exhaustion message is displayed even when TEFP with 900 VLAN has a QoS policy that is configured to match a single VLAN. As a result, the TEFP scale is affected.
- Configurable MAC is not supported on BDIs with multiple EFPs per port. If configured, it may lead to erroneous behaviour.
- The following features are not supported on BDIs with multiple EFPs:
 - BFD
 - All Layer3 multicast features
 - PTP
 - DHCP snooping
- 1024 EFPs per port are supported, which fall into the category of second or higher EFP configured under any BDI on that port.
- Fast Reroute (FRR) is not supported on BDI with multiple EFPs.
- By default, ARP throttling is not supported on RSP3 module as excess entries leads to error objects. You can use the **arp entries interface-limit** command to enable the throttle.

Ethernet Virtual Connections

You use the **ethernet evc** *evc-id* global configuration command to create an Ethernet virtual connection (EVC). The *evc-id* or name is a text string from 1 to 100 bytes. Entering this command puts the device into service configuration mode (config-srv) where you configure all parameters that are common to an EVC.

In this mode you can enter these commands:

- **default**—Sets a command to its defaults
- **exit**—Exits EVC configuration mode
- **no**—Negates a command or sets its defaults
- **oam**—Specifies the OAM Protocol
- **uni**—Configures a count UNI under EVC

Service Instances and EFPs

Configuring a service instance on a Layer 2 port or EtherChannel creates a pseudoport or Ethernet flow point (EFP) on which you configure EVC features. Each service instance has a unique number per interface, but you can use the same number on different interfaces because service instances on different ports are not related.

If you have defined an EVC by entering the **ethernet evc** *evc-id* global configuration command, you can associate the EVC with the service instance (optional). There is no default behavior for a service instance.

Use the **service instance** *number* **ethernet** [*name*] interface configuration command to create an EFP on a Layer 2 interface or EtherChannel and to enter service instance configuration mode. You use service instance configuration mode to configure all management and control data plane attributes and parameters that apply to the service instance on a per-interface basis.

- The **service instance** *number* is the EFP identifier, an integer from 1 to 4000.
- The optional **ethernet** *name* is the name of a previously configured EVC. You do not need to enter an EVC name, but you must enter **ethernet**. Different EFPs can share the same name when they correspond to the same EVC. EFPs are tied to a global EVC through the common name.

When you enter service instance configuration mode, you can configure these options:

- **default**—Sets a command to its defaults
- **description**—Adds a service instance specific description
- **encapsulation**—Configures Ethernet frame match criteria
- **ethernet**—Configures Ethernet-lmi parameters
- **exit**— Exits from service instance configuration mode
- **ip**—Interface Internet Protocol config commands
- **ipv6**—IPv6 interface subcommands
- **l2protocol**—Configures Layer 2 control protocol processing
- **mac**—Commands for MAC address-based features
- **no**—Negates a command or sets its defaults
- **service-policy** —Attaches a policy-map to an EFP
- **shutdown**—Takes the service instance out of service
Enter the [**no**] **shutdown** service-instance configuration mode to shut down or bring up a service instance.
- **snmp**—Modify SNMP service instance parameters

Encapsulation

Encapsulation defines the matching criteria that maps a VLAN, a range of VLANs, class of service (CoS) bits, Ethertype, or a combination of these to a service instance. You configure encapsulation in service instance configuration mode. You must configure one encapsulation command per EFP (service instance).

Use the **encapsulation** service-instance configuration mode command to set encapsulation criteria. Different types of encapsulations are default, dot1q, dot1ad, priority-tagged and untagged. Supported Ethernets include ipv4, ipv6, pppoe-all, pppoe-discovery, and pppoe-session.

Encapsulation classification options also include:

- outer tag VLAN
- outer tag CoS

- inner tag VLAN
- inner tag CoS
- payload ethertype

After you have entered an encapsulation method, these keyword options are available in service instance configuration mode:

- **bridge-domain**—Configures a bridge domain
- **rewrite**—Configures Ethernet rewrite criteria

Table 1: Supported Encapsulation Types

	Description
encapsulation dot1q <i>vlan-id</i> [<i>vlan-id</i> [- <i>vlan-id</i>]]	<p>Defines the matching criteria to be used to map 802.1Q frames ingress on an interface to the appropriate EFP. The options are a single VLAN, a range of VLANs, or lists of VLANs or VLAN ranges. VLAN IDs are 1 to 4094.</p> <ul style="list-style-type: none"> • Enter a single VLAN ID for an exact match of the outermost tag. • Enter a VLAN range for a ranged outermost match.
encapsulation dot1q <i>vlan-id</i> second-dot1q <i>vlan-id</i> [<i>vlan-id</i> [- <i>vlan-id</i>]]	<p>Double-tagged 802.1Q encapsulation. Matching criteria to be used to map QinQ frames ingress on an interface to the appropriate EFP. The outer tag is unique and the inner tag can be a single VLAN, a range of VLANs or lists of VLANs or VLAN ranges.</p> <ul style="list-style-type: none"> • Enter a single VLAN ID in each instance for an exact match of the outermost two tags. • Enter a VLAN range for second-dot1q for an exact outermost tag and a ranged second tag.
encapsulation dot1q { any <i>vlan-id</i> [<i>vlan-id</i> [- <i>vlan-id</i>]]} etype <i>ethertype</i>	<p>Ethertype encapsulation is the payload encapsulation type after VLAN encapsulation.</p> <ul style="list-style-type: none"> • ethertype—The etype string can have these values: ipv4, ipv6, pppoe-discovery, pppoe-session, or pppoe-all. • Matches any or an exact outermost VLAN or VLAN range and a payload ethertype.

	Description
encapsulation dot1q <i>vlan_id cos cos_value</i> second-dot1q <i>vlan-id cos cos_value</i>	<p>CoS value encapsulation defines match criterion after including the CoS for the S-Tag and the C-Tag. The CoS value is a single digit between 1 and 7 for S-Tag and C-Tag.</p> <p>You cannot configure CoS encapsulation with encapsulation untagged, but you can configure it with encapsulation priority-tag.</p> <p>The result is an exact outermost VLAN and CoS match and second tag. You can also use VLAN ranges.</p>
encapsulation dot1q any	encapsulation Matches any packet with one or more VLANs.
encapsulation dot1q add encapsulation dot1q add inner <i>vlan range</i> encapsulation dot1ad add encapsulation dot1ad add inner <i>vlan range</i>	<p>Adds one or more VLAN tag values for matching criteria. This command is also used with show run command when the encapsulation configuration command is more than the terminal width and ethernet service multi-line command is configured or if the encapsulation command is more than 255 characters.</p>
encapsulation dot1q remove encapsulation dot1ad remove	Removes one or more VLAN tag values for matching criteria.
ethernet service multi-line	<p>Permits use of multi-line output based on the screen width. This is applicable to encapsulation dot1q add command. This is visible only when show running config command is executed when this command is enabled.</p> <p>Values are <i>on</i> or <i>off</i></p>
encapsulation untagged	<p>Matching criteria to be used to map untagged (native) Ethernet frames entering an interface to the appropriate EFP.</p> <p>Only one EFP per port can have untagged encapsulation. However, a port that hosts EFP matching untagged traffic can also host other EFPs that match tagged frames.</p>

	Description
encapsulation default	<p>Configures the default EFP on an interface, acting as a catch-all encapsulation. All packets are seen as native. If you enter the rewrite command with encapsulation default, the command is rejected.</p> <p>If the default EFP is the only one configured on a port, it matches all ingress frames on that port. If you configure the default EFP on a port, you cannot configure any other EFP on the same port with the same bridge domain.</p> <p>You can configure only one default EFP per interface. If you try to configure more than one, the command is rejected.</p>
encapsulation priority-tagged	<p>Specifies priority-tagged frames. A priority-tagged packet has VLAN ID 0 and CoS value of 0 to 7.</p>

If a packet entering or leaving a port does not match any of the encapsulations on that port, the packet is dropped, resulting in *filtering* on both ingress and egress. The encapsulation must match the packet *on the wire* to determine filtering criteria. *On the wire* refers to packets ingressing the router before any rewrites and to packets egressing the router after all rewrites.



Note The router does not allow overlapping encapsulation configurations.

Ethertype

The router uses the default ether types 0x8100 and 0x88a8 for dot1q and Q-in-Q encapsulations.

The ethertypes 0x9100 and 0x9200 are supported using the custom ethertype feature by configuring the **dot1q tunneling ethertype** command on a physical port.

Custom ethertype allows configuration of the ethertype per port. The 0x9100 and 0x9200 ethertypes are supported in the custom ethertype model. 802.1q (0x8100) ethertype is the default ethertype, and is configured under each service instance.

Custom Ethertype

With the custom dot1q ethertype, you can select a non-standard (0x9100 and 0x9200) 2-byte ethertype in order to identify 802.1Q tagged frames. The router is allowed to interoperate with third party vendors' switches that do not use the standard 0x8100 ethertype to identify 802.1Q-tagged frames. For instance, if 0x9100 ethertype is used as the custom dot1q ethertype on a particular port, incoming frames containing the ethertype are assigned to the VLAN contained in the tag, immediately following the ethertype. Frames that arrive on that same port containing ethertypes other than 0x9100 and 0x8100 are forwarded to service instance with untagged encapsulation, if present.

The interface can be configured with the following ethertypes:

- 0x9100
- 0x9200

Restrictions for Custom Ethertypes

- If a custom ethertype is configured under a physical port, all tagged service instances under the physical port are forced to use that particular ethertype.
- Rewrite push is not supported on CET interfaces.
- Custom ethertype is *not* supported on IP configured/routed interfaces.
- Custom ethertype config 0x88a8 is *not* supported. Only 0x9100 and 0x9200 are supported.
- Custom Ethertype dynamic update from Dot1q to Tunneling or Tunneling to Dot1q is *not* supported.
- Outer 0x8100 packets are supported.
- Dot1q Tunneling Ethertype CFI preservation is *not* supported.
- CFM with Custom Ethertype is *not* supported.
- Mac-learning limit is *not* supported.
- 802.1ad not supported for CET.
- DHCP snooping not supported for CET.

Configuration Example

```
interface GigabitEthernet 0/0/1
  dot1q tunneling ethertype [0x9100 | 0x9200]
  service instance 1 ethernet
    encapsulation dot1q vlan 1 [second-dot1q vlan 2]
    rewrite ingress tag pop 1 symmetric
```

Split-Horizon

The split-horizon feature allows service instances in a bridge domain to join groups. Service instances in the same bridge domain and split-horizon group cannot forward data between each other, but can forward data between other service instances that are in the same bridge domain, but not in the same split-horizon group.

Service instances do not have to be in a split-horizon group. If a service instance does not belong to a group, it can send and receive from all ports within the bridge domain. A service instance cannot join more than one split-horizon group.

Enter the **bridge-domain *bridge-id* split-horizon group *group_id*** service-instance configuration mode command to configure a split-horizon group. The *group_id* is an integer from 0 to 2. All members of the bridge-domain that are configured with the same *group_id* are part of the same split-horizon group. EFPs that are not configured with an explicit *group_id* do not belong to any group.

You can configure no more than 64 service instances per bridge domain. When a bridge domain contains a service instance that is part of a split-horizon group, this decreases the number of service instances allowed to be configured in that split-horizon group. The switch supports up to three split-horizon groups plus the default (no group).

In Table 2, the left column means that a bridge domain belongs to a service instance that is part of the indicated split horizon group. Therefore, if a service instance joins split-horizon group 2, it can have no more than 16 members in split horizon group 2 in the same bridge domain. We recommend that you add split horizon groups in numerical order to maximize the number of service instances that can belong to a group.

Table 2: Maximum Allowed Service Instance Configuration with and without Split Horizons

Configured in Bridge Domain	Maximum Service Instances in the Group				Total Service Instances in Bridge Domain
	No group	Group 0	Group 1	Group 2	
No Group 1	64	–	–	–	64
Split Group 0	32	32	–	–	64
Split Group 1	16	16	16	–	48
Split Group 2	16	16	16	16	64

¹ No group refers to a bridge-domain not belonging to any split horizon group. The traffic flows between the EFPs in the same bridge-domain.

**Note**

- If you configure Split-horizon feature on a bridge-domain without any specific group number mentioned (using only split-horizon keyword without any group number), then by default it is part of group 0 and the scale is inherited as in the Table 2.
- If a VPLS VFI is part of the bridge-domain configuration, the VPLS is by default part of Split-horizon group 0 and the scale for Split-horizon group 1-2 and No group is applicable as in the Table 2.
- If there is a Layer3 BDI associated with the bridge-domain, then the maximum number of EFPs supported on the bridge-domain is 24.
- Layer3 BDI interface counter does not increment for traffic transit through Cisco RSP3 Module.

Restrictions for Split-Horizon on RSP2

- Maximum number of EFPs per bridge-domain is 128. The EFPs can be distributed among split-horizon groups 0 to 13.
- VPLS uses the reserved internal Split-horizon group 15 which *does not* overlap with manually configured split groups. In case VPLS is configured on the same bridge-domain, the scale of 128 EFPs is achieved on the same bridge-domain.
- 64 VFIs are supported on the same bridge-domain.

Split Horizon Enhancements on the RSP3 Module

Starting with Cisco IOS XE Release 16.6.1, the **efp_feat_ext** template is introduced. This template when enabled allows configuration of two split-horizon groups on the EVC bridge-domain.

- Two Split-horizon groups—Group 0 and Group 1 are configured through using the **bridge-domain bd number split-horizon group 0-1** command.

Prerequisites for Split-Horizon Groups on the RSP3 Module

- The `efp_feat_ext` template must be configured to enable the feature.
- Metro services license must be enabled; `LICENSE_ACTIVE_LEVEL=metroaggrservices,all:ASR-903`;

Restrictions for Split-Horizon Groups on the RSP3 Module

- The overall scale of EFPs is 8K, only if the split-horizon groups are configured. For information, see supported scale.



Note If split-horizon based-EFPs are not configured, the total EFPs supported are 4K.

- EFPs configured on the same bridge domain and same split-horizon group, cannot forward to or receive traffic from each other.
- We do not recommend configuration of Y.1564 and split-horizon group on the same EFP.
- We do not recommend configuring MAC security with split-horizon group.
- Split-horizon group is not supported for CFM on this template. Configuring split-horizon groups on CFM based MEPs may result in MEPs being unlearned, and unexpected behavior may be observed.
- If ethernet loopback is configured, and if a dynamic change in split-horizon group occurs on the EFP-BD, the ELB session must be restarted.
- A change in the split-horizon group configuration on a regular EFP results in hardware programming update and may impact L2 traffic. This results in a MAC-flush and re-learn of traffic with new MAC address.

Following are known behavior of split-horizon groups:

- Changing the split-horizon group on any EFP, results in traffic flooding back to same EFP for few milliseconds.
- A small traffic leak may be observed on defaulting an interface with higher number of EFP with split-horizon configured.
- BFD flaps and underlying IGP flaps may be observed upon changing split-horizon groups, if BFD is hardware based.

Split-Horizon Supported Scale

8K EFPs are supported across RSP3-400 and 4K EFPs on RSP3-200.



Note If Split-horizon configuration does not exist, number of EFPs supported are reduced to 4K EFPs.

Table 3: Split-Horizon Supported Template

Split-Horizon Group	RSP3-400	RSP3-200
Default (No config)	4K EFP	2K EFP
Group 0	2K EFP	1K EFP
Group 1	2K EFP	1K EFP



Note Port-channel scale is half the regular scale of the EFP.

Configuring Split-Horizon Group on the RSP3 Module

```
interface GigabitEthernet0/2/2
service instance 1 ethernet
  encapsulation dot1q 100
  bridge-domain 100 split-horizon group 0 □ When you configure split-horizon group 0, (0
is optional)

interface GigabitEthernet0/2/2
service instance 2 ethernet
  encapsulation dot1q 102
  bridge-domain 102 split-horizon group 1 □ When you configure split-horizon group 1
```

Bridge Domains

A service instance must be attached to a bridge domain. Flooding and communication behavior of a bridge domain is similar to that of a VLAN domain. Bridge-domain membership is determined by which service instances have joined it, while VLAN domain membership is determined by the VLAN tag in the packet.



Note You must configure encapsulation before you can configure the bridge domain.

Use the **bridge-domain** *bridge-id* service-instance configuration mode command to bind the EFP to a bridge domain instance. The *bridge-id* is the identifier for the bridge domain instance, an integer from 1 to 4000.

You can enable BDI MTU using the **enable_bdi_mtu sdm** template.

Setting Bandwidth

We recommend you set the bandwidth of the BDI associated with 1-Gigabit Ethernet or 10-Gigabit Ethernet interfaces. The default BDI value is 1 Gigabit for both, 1-Gigabit Ethernet and 10-Gigabit Ethernet interfaces.

Use the **bandwidth** command to set the bandwidth on the interfaces.

The following example shows the bandwidth configuration for BDI interface 120:

```
Router(config)# interface bdi 120
Router(config-if)# bandwidth 10000000
Router(config-if)# end
```

The following example displays the configured bandwidth for BDI interface 120:

```
Router# show interface bdi 120
BDI120 is up, line protocol is up
  Hardware is BDI, address is 7426.acf7.2ebf (bia 7426.acf7.2ebf)
  Internet address is 192.168.1.1/24
  MTU 1500 bytes, BW 10000000 Kbit/sec, DLY 10 usec
```

Rewrite Operations

You can use the **rewrite** command to modify packet VLAN tags. You can use this command to emulate traditional 802.1Q tagging, where packets enter a router on the native VLAN and VLAN tagging properties are added on egress. You can also use the **rewrite** command to facilitate VLAN translation and QinQ.

The Cisco router supports only these **rewrite** commands.

- **rewrite ingress tag pop 1 symmetric**
- **rewrite ingress tag pop 2 symmetric**
- **rewrite ingress tag push dot1q *vlan-id* symmetric**

Enter the **rewrite ingress tag pop {1 | 2} symmetric** service-instance configuration mode command to specify the encapsulation adjustment to be performed on the frame ingress to the EFP. Entering **pop 1** pops (removes) the outermost tag; entering **pop 2** removes two outermost tags.



Note The **symmetric** keyword is required to complete **rewrite** to configuration.

When you enter the **symmetric** keyword, the egress counterpart performs the inverse action and pushes (adds) the encapsulation VLAN. You can use the **symmetric** keyword only with ingress rewrites and only when single VLANs are configured in encapsulation. If you configure a list of VLANs or a VLAN range or **encapsulation default** or **encapsulation any**, the **symmetric** keyword is not accepted for rewrite operations.

Restrictions for Rewrite

- The router does *not* support **rewrite** commands for **translate** in release 3.7.
- Possible translation combinations are 1-to-1, 1-to-2, 2-to-1, and 2-to-2. When forwarding to or from a Layer 2 port, you cannot achieve 2-to-2 translation because a Layer 2 port is implicitly defined to be **rewrite ingress tag pop 1 symmetric**.
- The router does *not* support egress rewrite operations beyond the second VLAN that a packet carries. Because of the egress rewrite limitation, if an EFP has a **pop 2 rewrite** operation at ingress, no other EFP in the same bridge domain can have a rewrite operation.
- Rewrite PUSH configuration over port-channel is *not* supported for bridge domain interfaces.

Static MAC Addresses

The Cisco router supports multicast static MAC addresses, which allow you to enable multicast at the layer 2 level. You can use multicast static MAC addresses to forward multicast packets to specific EFPs on a network.

For instructions on how to configure static MAC addresses, see [Configuring a Static MAC Address](#).

Layer 2 Protocol Features

The Cisco router supports layer 2 protocol peering, forwarding, and tunneling on CDP, LACP, LLDP, PAGP, STP, UDLD, and VTP traffic. For more information about these features, see:

- [Layer 2 Protocol Peering](#)
- [Layer 2 Protocol Forwarding](#)
- [Layer 2 Protocol Tunneling](#)

Configuring EFPs

Default EVC Configuration

No EFPs are configured. No service instances or bridge domains are configured.

Configuration Guidelines

The following guidelines apply when you configure EVCs.



Note

For information about supported EVC scale, see the [Cisco NCS 4200 Series Software Configuration Guide](#).

- To configure a service instance on an interface, these commands are prerequisites:

```
Router (config)# interface gigabitethernet0/0/1
Router (config-if)# service instance 22 Ethernet ether
Router (config-if-srv)# encapsulation dot1q 10
Router (config-if-srv)# bridge-domain 10
```

- You must configure encapsulation on a service instance before configuring bridge domain.
- ISL trunk encapsulation is not supported.
- The router does not support overlapping configurations on the same interface and same bridge domain. If you have configured a VLAN range encapsulation, or encapsulation default, or encapsulation any on service instance 1, you cannot configure any other encapsulations that also match previous encapsulations in the same interface and bridge domain.
- QinQ is not supported on Trunk EFP interfaces.

Creating Service Instances

Beginning in privileged EXEC mode, follow these steps to create an EFP service instance:

SUMMARY STEPS

1. **configure terminal**

2. **interface** *interface-id*
3. **service instance** *number ethernet* [*name*]
4. **encapsulation** {**default** | **dot1q** | **priority-tagged** | **untagged**}
5. **rewrite ingress tag pop** {**1** | **2**} **symmetric**
6. **bridge-domain** *bridge-id* [**split-horizon group** *group-id*]
7. **end**
8. **show ethernet service instance show bridge-domain** [*n* | **split-horizon**]
9. **copy running-config startup-config**

DETAILED STEPS

	Command or Action	Purpose
Step 1	configure terminal	Enter global configuration mode.
Step 2	interface <i>interface-id</i>	Specify the port to attach to the policy map, and enter interface configuration mode. Valid interfaces are physical ports.
Step 3	service instance <i>number ethernet</i> [<i>name</i>]	Configure an EFP (service instance) and enter service instance configuration mode. <ul style="list-style-type: none"> • The number is the EFP identifier, an integer from 1 to 4000. • (Optional) ethernet name is the name of a previously configured EVC. You do not need to use an EVC name in a service instance.
Step 4	encapsulation { default dot1q priority-tagged untagged }	Configure encapsulation type for the service instance. <ul style="list-style-type: none"> • default—Configure to match all unmatched packets. • dot1q—Configure 802.1Q encapsulation. See for details about options for this keyword. • priority-tagged—Specify priority-tagged frames, VLAN-ID 0 and CoS value of 0 to 7. • untagged—Map to untagged VLANs. Only one EFP per port can have untagged encapsulation.
Step 5	rewrite ingress tag pop { 1 2 } symmetric	(Optional) Specify that encapsulation modification to occur on packets at ingress. <ul style="list-style-type: none"> • pop 1—Pop (remove) the outermost tag. • pop 2—Pop (remove) the two outermost tags. • symmetric—Configure the packet to undergo the reverse of the ingress action at egress. If a tag is popped at ingress, it is pushed (added) at egress. This keyword is required for rewrite to function properly.

	Command or Action	Purpose
Step 6	bridge-domain <i>bridge-id</i> [split-horizon group <i>group-id</i>]	Configure the bridge domain ID. The range is from 1 to 4000. You can use the split-horizon keyword to configure the port as a member of a split horizon group. The <i>group-id</i> range is from 0 to 2.
Step 7	end	Return to privileged EXEC mode.
Step 8	show ethernet service instance show bridge-domain [<i>n</i> split-horizon]	Verify your entries.
Step 9	copy running-config startup-config	(Optional) Save your entries in the configuration file. Use the no forms of the commands to remove the service instance, encapsulation type, or bridge domain or to disable the rewrite operation.

Creating a Trunk EFP

Beginning in privileged EXEC mode, follow these steps to create an EFP service instance:



Note Use the no forms of the commands to remove the service instance, encapsulation type, or bridge domain or to disable the rewrite operation.



Note Trunk EFPs on port-channel interfaces is supported. Traffic may *not* flow to the TEFP when the port-channel or its member links are in down state.

SUMMARY STEPS

1. **configure terminal**
2. **interface** *interface-id*
3. **service instance** [**trunk**] *number* **ethernet**
4. **encapsulation** {**default** | **dot1q** | **priority-tagged** | **untagged**}
5. **rewrite ingress tag pop** {**1** | **2**} **symmetric**
6. **bridge-domain** *bridge-id*
7. **end**
8. Use one of the following commands
 - **show ethernetservice instance**
 - **show bridge-domain** [*n* | **split-horizon**]
9. **copy running-config startup-config**

DETAILED STEPS

	Command or Action	Purpose
Step 1	<code>configure terminal</code>	Enter global configuration mode.
Step 2	<code>interface interface-id</code>	Specify the port to attach to the policy map, and enter interface configuration mode. Valid interfaces are physical ports.
Step 3	<code>service instance [trunk] number ethernet</code>	<p>Configure an EFP (service instance) and enter service instance configuration mode.</p> <ul style="list-style-type: none"> The number is the EFP identifier, an integer from 1 to 4000. The trunk keyword identifies the trunk ID to which the service instance is assigned. <p>Note Trunk EFP (without port channel) supports encapsulation of up to 1000 VLANs.</p>
Step 4	<code>encapsulation {default dot1q priority-tagged untagged}</code>	<p>Note Only dot1q encapsulation is supported on trunk EFPs.</p> <p>Configure encapsulation type for the service instance.</p> <ul style="list-style-type: none"> default—Configure to match all unmatched packets. dot1q—Configure 802.1Q encapsulation. See Table 1 for details about options for this keyword. priority-tagged—Specify priority-tagged frames, VLAN-ID 0 and CoS value of 0 to 7. untagged—Map to untagged VLANs. Only one EFP per port can have untagged encapsulation.
Step 5	<code>rewrite ingress tag pop {1 2} symmetric</code>	<p>(Optional) Specify that encapsulation modification to occur on packets at ingress.</p> <ul style="list-style-type: none"> pop 1—Pop (remove) the outermost tag. pop 2—Pop (remove) the two outermost tags. <p>Caution The pop2 option is not currently supported on Trunk EFPs.</p> <ul style="list-style-type: none"> symmetric—Configure the packet to undergo the reverse of the ingress action at egress. If a tag is popped at ingress, it is pushed (added) at egress. This keyword is required for rewrite to function properly.
Step 6	<code>bridge-domain bridge-id</code>	Configures the router to derive bridge domains from the encapsulation VLAN list.
Step 7	<code>end</code>	Return to privileged EXEC mode.

	Command or Action	Purpose
Step 8	Use one of the following commands <ul style="list-style-type: none"> • show ethernetservice instance • show bridge-domain [n split-horizon] 	Verify your entries.
Step 9	copy running-config startup-config	(Optional) Save your entries in the configuration file.

Configuring Asymmetric EFPs

You can configure asymmetric rewrite rules in both ingress and egress directions of the EFP.

Encapsulation (EVC filtering) is verified at the egress for these rewrite rules:

- No rewrite rule
- Rewrite rule is **rewrite ingress tag push dot1q <value> symmetric**
- Rewrite rule is **rewrite ingress tag push dot1q <value>**
- Rewrite rule is **rewrite egress tag pop 1**

Pre-requisites

- Ensure that split-horizon groups are configured to avoid flooding between EFPs of the same Bridge Domain (BD).

Restrictions

- Transparent CFM is not supported with Asymmetric EFP.
- Q-in-Q encapsulation type in the EFP is not supported. Frames with dot1q greater than value 1 is supported. Dot1ad is not supported.
- Trunk-EFPs usage is not supported
- 2 Tag push or pop is not supported.
- Translate option, in VLAN Translation, is not supported with asymmetric rewrite rules.
- External Loopback operations are not supported.
- Ignoring MLD reports (IPv6) is not supported
- When the encapsulation is untagged in one of the EFPs, for example if **rewrite egress tag pop 1** is configured on the EFP, then **rewrite ingress tag pop 1** will cancel the rewrite rule and the packet is sent without rewrites.
- If there are different EFPs in the same BD that are carrying unicast and multicast traffic, then MAC learning should be disabled on the multicast EFP using **disable-learning** command.
- Asymmetric rewrite configuration fails for the priority-tagged encapsulation.

- When the encapsulation is untagged in one of the EFPs, for example if **rewrite egress tag pop 1** is configured on the EFP, then single tagged frames will cancel the rewrite rule and the packet is sent without rewrites.
- When two EFPs are configured at the egress under the same bridge-domain such that one of the EFPs matches the tag pushed at the egress and the other EFP does not check for encapsulation match, MAC movement can happen between the EFPs which would lead the VLAN tagging output based on the EFP on which the MAC address is learnt at the given point in time. This is an expected behavior by design. Split-horizon can be used to isolate the EFPs to avoid this behavior.

Procedure

```
enable
configure terminal
interface TenGigabitEthernet0/0/26
no ip address
service instance 1 ethernet
encapsulation dot1q 30
rewrite ingress tag pop 1
igmp ingress ignore-rewrite
bridge-domain 30
end
```

Configuration Examples

Example for Configuring a Service Instance

```
Router (config)# interface gigabitethernet0/0/1
Router (config-if)# service instance 22 Ethernet ether
Router (config-if-srv)# encapsulation dot1q 10
Router (config-if-srv)# bridge-domain 10
```

Example for Encapsulation Using a VLAN Range

```
Router (config)# interface gigabitethernet0/0/1
Router (config-if)# service instance 22 Ethernet
Router (config-if-srv)# encapsulation dot1q 22-44
Router (config-if-srv)# bridge-domain 10
```

Configuration Example for Larger String VLAN in Encapsulation

Configuration Example

```
show running config

ethernet service multi-line
!
interface GigabitEthernet0/0/0
service instance 1 ethernet
encapsulation dot1q 10,13,19-21,24,29,32-36,41,46-48,55,61,63-66
encapsulation dot1q add 69-73,78,80,83-86
```

Example for Two Service Instances Joining the Same Bridge Domain

```

!
service instance 2 ethernet
encapsulation dot1q 1 second-dot1q 10,13,19-21,24,29,32-36,41
encapsulation dot1q add outer 2-5,7
encapsulation dot1q add inner 46-48,55,61,63-66,69-73,78,80,83-86
encapsulation dot1q add inner 91,95-99,101
!
interface GigabitEthernet0/0/0
ethernet dot1ad nni
service instance 3 ethernet
encapsulation dot1ad 10,13,19-21,24,29,32-36,41,46-48,55,61,63-66
encapsulation dot1ad add 69-73,78,80,83-86
!
service instance 4 ethernet
encapsulation dot1ad 1 dot1q 10,13,19-21,24,29,32-36,41,46-48,55
encapsulation dot1ad add inner 61,63-66,69-73,78,80,83-86
!
!

```

Example for Two Service Instances Joining the Same Bridge Domain

In this example, service instance 1 on interfaces Gigabit Ethernet 0/0/1 and 0/0/2 can bridge between each other.

```

Router (Router (config)# interface gigabitethernet0/0/1
Router (config-if)# service instance 1 Ethernet
Router (config-if-srv)# encapsulation dot1q 10
Router (config-if-srv)# bridge-domain 10

Router (config)# interface gigabitethernet0/0/2
Router (config-if)# service instance 1 Ethernet
Router (config-if-srv)# encapsulation dot1q 10
Router (config-if-srv)# bridge-domain 10

```

Example for Bridge Domains and VLAN Encapsulation

Unlike VLANs, the bridge-domain number does not need to match the VLAN encapsulation number.

```

Router (config)# interface gigabitethernet0/0/1
Router (config-if)# service instance 1 Ethernet
Router (config-if-srv)# encapsulation dot1q 10
Router (config-if-srv)# bridge-domain 3000

Router (config)# interface gigabitethernet0/0/2
Router (config-if)# service instance 1 Ethernet
Router (config-if-srv)# encapsulation dot1q 20
Router (config-if-srv)# bridge-domain 3000

```

However, when encapsulations do not match in the same bridge domain, traffic cannot be forwarded. In this example, the service instances on Gigabit Ethernet 0/0/1 and 0/0/2 can not forward between each other, since the encapsulations don't match (filtering criteria). However, you can use the **rewrite** command to allow communication between these two.

```

Router (config)# interface gigabitethernet0/0/1
Router (config-if)# service instance 1 Ethernet
Router (config-if-srv)# encapsulation dot1q 10
Router (config-if-srv)# bridge-domain 3000

```

```
Router (config)# interface gigabitethernet0/0/2
Router (config-if)# service instance 1 Ethernet
Router (config-if-srv)# encapsulation dot1q 99
Router (config-if-srv)# bridge-domain 3000
```

Example for Rewrite

In this example, a packet that matches the encapsulation will have one tag removed (popped off). The **symmetric** keyword allows the reverse direction to have the inverse action: a packet that egresses out this service instance will have the encapsulation (VLAN 10) added (pushed on).

```
Router (config)# interface gigabitethernet0/0/1
Router (config-if)# service instance 1 Ethernet
Router (config-if-srv)# encapsulation dot1q 10
Router (config-if-srv)# rewrite ingress tag pop 1 symmetric
Router (config-if-srv)# bridge-domain 3000
```

Example for Split Horizon

In this example, service instances 1 and 2 cannot forward and receive packets from each other. Service instance 3 can forward traffic to any service instance in bridge domain 3000 since no other service instance in bridge domain 3000 is in split-horizon group 2. Service instance 4 can forward traffic to any service instance in bridge domain 3000 since it has not joined any split-horizon groups.

```
Router (config)# interface gigabitethernet0/0/1
Router (config-if)# service instance 1 Ethernet
Router (config-if-srv)# encapsulation dot1q 10
Router (config-if-srv)# rewrite ingress pop 1 symmetric
Router (config-if-srv)# bridge-domain 3000 split-horizon group 1
Router (config-if-srv)# exit
Router (config-if)# service instance 2 Ethernet
Router (config-if-srv)# encapsulation dot1q 99
Router (config-if-srv)# rewrite ingress pop 1 symmetric
Router (config-if-srv)# bridge-domain 3000 split-horizon group 1

Router (config)# interface gigabitethernet0/0/2
Router (config-if)# service instance 3 Ethernet
Router (config-if-srv)# encapsulation dot1q 10
Router (config-if-srv)# rewrite ingress pop 1 symmetric
Router (config-if-srv)# bridge-domain 3000 split-horizon group 2
Router (config-if-srv)# exit
Router (config-if)# service instance 4 Ethernet
Router (config-if-srv)# encapsulation dot1q 99
Router (config-if-srv)# rewrite ingress pop 1 symmetric
Router (config-if-srv)# bridge-domain 3000
```

Example for Hairpinning

The switch supports *hairpinning*, which refers to traffic ingressing and egressing same interface. To achieve haripinning, configure two EFPs in the same bridge domain on the same physical interface, as in this example.

```
Router (config)# interface gigabitethernet0/0/2
Router (config-if)# service instance 1 Ethernet
Router (config-if-srv)# encapsulation dot1q 10
Router (config-if-srv)# rewrite ingress tag pop 1 symmetric
```

```

Router (config-if-srv)# bridge-domain 4000
Router (config-if-srv)# exit
Router (config-if)# service instance 2 Ethernet
Router (config-if-srv)# encapsulation dot1q 20
Router (config-if-srv)# rewrite ingress tag pop 1 symmetric
Router (config-if-srv)# bridge-domain 4000

```

Example for Egress Filtering

In EVC switching, egress filtering is performed before the frame is sent on the egress EFP. Egress filtering ensures that when a frame is sent, it conforms to the matching criteria of the service instance applied on the ingress direction. EFP does not require egress filtering if the number of pops is the same as the number of VLANs specified in the **encapsulation** command.

Egress Filtering is not supported on the RSP3 module.



Note

Specifying the **cos** keyword in the encapsulation command is relevant only in the ingress direction. For egress filtering, **cos** is ignored.

For example, consider the following configuration.

```

Router (config)# interface gigabitethernet0/0/1
Router (config-if)# service instance 1 Ethernet
Router (config-if-srv)# encapsulation dot1q 20
Router (config-if-srv)# bridge-domain 19

Router (config)# interface gigabitethernet0/0/2
Router (config-if)# service instance 2 Ethernet
Router (config-if-srv)# encapsulation dot1q 30
Router (config-if-srv)# bridge-domain 19

Router (config)# interface gigabitethernet0/0/3
Router (config-if)# service instance 3 Ethernet
Router (config-if-srv)# encapsulation dot1q 10 second-dot1q 20
Router (config-if-srv)# rewrite ingress pop 1 symmetric
Router (config-if-srv)# bridge-domain 19

```

If a packet with VLAN tag 10 or 20 is received on Gigabit Ethernet 0/0/3, the ingress logical port would be service instance 3. For the frame to be forwarded on a service instance, the egress frame must match the encapsulation defined on that service instance after the rewrite is done. Service instance 1 checks for outermost VLAN 20; service instance 2 checks for VLAN 30. In this example, the frame with VLAN tags 10 and 20 can be sent to service instance 1 but not to service instance 2.

Configuring Examples for Asymmetric EFPs

Configuring Asymmetric EFP with POP

```

enable
configure terminal
interface TenGigabitEthernet0/0/26
no ip address
service instance 1 ethernet
encapsulation untagged
rewrite egress tag pop 1

```

```
bridge-domain 30
end
```

Configuring Asymmetric EFP with Single Tag Push

```
enable
configure terminal
interface TenGigabitEthernet0/0/26
no ip address
service instance 1 ethernet
encapsulation untagged
rewrite ingress tag push dot1q 10
bridge-domain 30
end
```

Configuring Asymmetric EFP with Ingress VLAN Rewrite Disabled for IGMP Control Packets"

```
enable
configure terminal
interface TenGigabitEthernet0/0/26
no ip address
service instance 1 ethernet
encapsulation dot1q 30
rewrite ingress tag pop 1
igmp ingress ignore-rewrite
bridge-domain 30
end
```

Configuring Asymmetric EFP with Disabled MAC Address Learning

```
enable
configure terminal
interface TenGigabitEthernet0/0/26
no ip address
service instance 1 ethernet
encapsulation dot1q 30
rewrite egress tag push dotq 30
disable-learning
bridge-domain 30 split-horizon group 1
end
```

Configuring Other Features on EFPs

EFPs and EtherChannels

You can configure EFP service instances on EtherChannel port channels, but EtherChannels are not supported on ports configured with service instances. Load-balancing on port channels is based on the MAC address or IP address of the traffic flow on the EtherChannel interface.

This example configures a service instance on an EtherChannel port channel. Configuration on the ports in the port channel are independent from the service instance configuration.

```
Router (config)# interface port-channel 4
Router (config-if)# service instance 1 ethernet
Router (config-if-srv)# encapsulation untagged
Router (config-if-srv)# bridge-domain {any vlan}
Router (config-if-srv)# l2protocol peer {lACP | pagp}
```

Layer 2 Protocol Peering

For Layer 2 protocols (CDP, UDLD, LLDP, MSTP, LACP, PAGP, VTP, and DTP) to peer with a neighbor on a port that has an EFP service instance configured, you need to enter the **l2 protocol peer protocol** service-instance configuration command on the service instance.

This example shows how to configure CDP to peer with a neighbor on a service instance:

```
Router (config)# interface gigabitEthernet0/0/1
Router (config-if)# service instance 1 Ethernet
Router (config-if-srv)# encapsulation untagged
Router (config-if-srv)# l2protocol peer cdp
Router (config-if-srv)# bridge-domain 10
Router (config-if-srv)# end
```

Layer 2 Protocol Forwarding

Layer 2 protocol forwarding is based on the bridge domain ID and the destination MAC address.

Selecting the l2protocol forward option causes the router to flood interfaces in the same VLAN or bridge-domain with untagged or tagged BPDU packets. You can apply the l2protocol forward command to CDP, LACP, LLDP, PAGP, STP, UDLD, and VTP traffic. This is an example how to configure the l2protocol forward option:

```
interface GigabitEthernet0/0/9
ethernet uni id PRAV-PE2
service instance 1 ethernet
encapsulation untagged
l2protocol forward cdp
bridge-domain 500
!
service instance 10 ethernet xcon
encapsulation dot1q 100
l2protocol forward cdp
xconnect 4.3.2.1 12 encapsulation mpls
!
```

Configuring IEEE 802.1Q Tunneling and Layer 2 Protocol Tunneling Using EFPs

Tunneling is a feature used by service providers whose networks carry traffic of multiple customers and who are required to maintain the VLAN and Layer 2 protocol configurations of each customer without impacting the traffic of other customers. The Cisco router uses EFPs to support QinQ and Layer 2 protocol tunneling.

802.1Q Tunneling (QinQ)

Service provider customers often have specific requirements for VLAN IDs and the number of VLANs to be supported. The VLAN ranges required by different customers in the same service-provider network might overlap, and traffic of customers through the infrastructure might be mixed. Assigning a unique range of

VLAN IDs to each customer would restrict customer configurations and could easily exceed the VLAN limit (4096) of the 802.1Q specification.

Using the EVCs, service providers can encapsulate packets that enter the service-provider network with multiple customer VLAN IDs (C-VLANs) and a single 0x8100 Ethertype VLAN tag with a service provider VLAN (S-VLAN). Within the service provider network, packets are switched based on the S-VLAN. When the packets egress the service provider network onto the customer network, the S-VLAN tag is decapsulated and the original customer packet is restored.

Figure below shows the tag structures of the double-tagged packets.

In figure below, Customer A was assigned VLAN 30, and Customer B was assigned VLAN 40. Packets entering the edge switches with 802.1Q tags are double-tagged when they enter the service-provider network, with the outer tag containing VLAN ID 30 or 40, appropriately, and the inner tag containing the original VLAN number, for example, VLAN 100. Even if both Customers A and B have VLAN 100 in their networks, the traffic remains segregated within the service-provider network because the outer tag is different. Each customer controls its own VLAN numbering space, which is independent of the VLAN numbering space used by other customers and the VLAN numbering space used by the service-provider network. At the outbound port, the original VLAN numbers on the customer's network are recovered.

Method 1

In this example, for Customer A, interface Gigabit Ethernet 0/0/1 is the customer-facing port, and Gigabit Ethernet 0/0/2 is a trunk port facing the service provider network. For Customer B, Gigabit Ethernet 0/0/3 is the customer-facing port, and Gigabit Ethernet 0/0/4 is the trunk port facing the service provider network.

Customer A

```
Router (config)# interface gigabitethernet0/0/1
Router (config-if)# service instance 1 Ethernet
Router (config-if-srv)# encapsulation dot1q 1-100
Router (config-if-srv)# bridge-domain 4000

Router (config)# interface gigabitethernet0/0/2
Router (config-if)# service instance 2 Ethernet
Router (config-if-srv)# encapsulation dot1q 30

Router (config-if-srv)# rewrite ingress tag push dot1q 1 symmetric
Router (config-if-srv)# bridge-domain 4000
```

For Customer A, service instance 1 on Gigabit Ethernet 0/0/1 is configured with the VLAN encapsulations used by the customer: C-VLANs 1–100. These are forwarded on bridge-domain 4000. The service provider facing port is configured with a service instance on the same bridge-domain and with an **encapsulation dot1q** command matching the S-VLAN. The **rewrite ingress pop 1 symmetric** command also implies a push of the configured encapsulation on egress packets. Therefore, the original packets with VLAN tags between 1 and 100 are encapsulated with another S-VLAN (VLAN 30) tag when exiting Gigabit Ethernet port 0/0/2.

Similarly, for double-tagged (S-VLAN = 30, C-VLAN = 1–100) packets coming from the provider network, the **rewrite ingress pop 1 symmetric** command causes the outer S-VLAN tag to be popped and the original C-VLAN tagged frame to be forwarded over bridge-domain 4000 out to Gigabit Ethernet 0/0/1.

The same scenario applies to Customer B.

Customer B

```
Router (config)# interface gigabitethernet0/0/3
Router (config-if)# service instance 1 Ethernet
Router (config-if-srv)# encapsulation dot1q 1-200
```

```

Router (config-if-srv)# bridge-domain 4000

Router (config)# interface gigabitethernet0/0/4
Router (config-if)# service instance 2 Ethernet
Router (config-if-srv)# encapsulation dot1q 40

Router (config-if-srv)# rewrite ingress tag push dot1q 1 symmetric
Router (config-if-srv)# bridge-domain 4000

```

Method 2

QinQ is also supported when sending packets between an EFP and a trunk EFP. The same external behavior as Method 1 can be achieved with this configuration:

Customer A

```

Router (config)# interface gigabitethernet0/0/1
Router (config-if)# service instance 1 Ethernet
Router (config-if-srv)# encapsulation dot1q 1-100
Router (config-if-srv)# bridge-domain 30
Router (config)# interface gigabitethernet0/0/2
Router (config-if)# service instance 1 ethernet
Router (config-if-srv)# encapsulation dot1q 30

Router (config-if-srv)# rewrite ingress tag push dot1q 1 symmetric
Router (config-if-srv)# bridge-domain from-encapsulation

```

Again, service instance 1 on Gigabit Ethernet port 0/0/1 is configured with the VLAN encapsulations used by the customer. These are forwarded on bridge-domain 30. The service provider facing port is configured as a trunk port. The trunk port pushes a tag matching the bridge-domain that the packet is forwarded on (in this case S-VLAN 30).

For double tagged (S-VLAN = 30, C-VLAN = 1 to 100) packets coming in from the provider network, the trunk port pops the outer S-VLAN (30) and forwards the packet on that bridge-domain.

Customer B

```

Router (config)# interface gigabitethernet0/0/3
Router (config-if)# service instance 1 Ethernet
Router (config-if-srv)# encapsulation dot1q 1-200
Router (config-if-srv)# bridge-domain 40
Router (config)# interface gigabitethernet0/0/4
Router (config-if)# service instance 2 Ethernet
Router (config-if-srv)# encapsulation dot1q 40

Router (config-if-srv)# rewrite ingress tag push dot1q 1 symmetric
Router (config-if-srv)# bridge-domain from-encapsulation

```

You can also combine the customer A and B configurations, as follows:

Customer A and B

```

Router (config)# interface gigabitethernet0/0/2
Router (config-if)# service instance 1 ethernet
Router (config-if-srv)# encapsulation dot1q 30,40

Router (config-if-srv)# rewrite ingress tag push dot1q 1 symmetric
Router (config-if-srv)# bridge-domain from-encapsulation

```

For information about the effect on cost of service (CoS) for different EFT tagging operations, see the [Cisco ASR 903 Router Chassis Software Configuration Guide](#).

Example for VLAN Translation Configurations

- For 1-to-1 VLAN translation (EFP to EFP), ingress port configuration:

```
Router (config)# interface gigabitethernet0/0/1
Router (config-if)# service instance 10 Ethernet
Router (config-if-srv)# encapsulation dot1q 10
Router (config-if-srv)# rewrite ingress tag pop 1 symmetric
Router (config-if-srv)# bridge-domain 10
```

You must apply the QoS policy in case of ingress EVC with the **rewrite push** option.

```
Router (config)# interface gigabitethernet0/0/1
Router (config-if)# service instance 1 Ethernet
Router (config-if-srv)# encapsulation untagged
Router (config-if-srv)# rewrite ingress tag push dot1q 10
Router (config-if-srv)# service policy input policy-dscp
Router (config-if-srv)# bridge-domain 20
```

Egress port configuration:

```
Router (config)# )# interface gigabitethernet0/0/1
Router (config-if)# service instance 10 Ethernet
Router (config-if-srv)# encapsulation dot1q 20
Router (config-if-srv)# rewrite ingress tag pop 1 symmetric
Router (config-if-srv)# bridge-domain 10
```

Egress interface with EVC pop and EVC policy:

```
Router (config)# )# interface gigabitethernet0/0/3
Router (config-if)# service instance 1 Ethernet
Router (config-if-srv)# encapsulation dot1q 30
Router (config-if-srv)# rewrite ingress tag pop 1 symmetric
Router (config-if-srv)# service policy output policy-dscp
Router (config-if-srv)# bridge-domain 20
```

In the above example, GigabitEthernet 0/0/3 is the output interface and GigabitEthernet 0/0/1 is the input interface. If you want to apply the EVC policy in the output direction on GigabitEthernet 0/0/3, ensure that you apply the same criteria for the input policy for the incoming traffic on GigabitEthernet 0/0/1.

- For 1-to-2 VLAN translation (EFP to EFP), ingress port configuration:

```
Router (config)# interface gigabitethernet0/0/1
Router (config-if)# service instance 10 Ethernet
Router (config-if-srv)# encapsulation dot1q 10
Router (config-if-srv)# rewrite ingress tag pop 1 symmetric
Router (config-if-srv)# bridge-domain 10
```

Egress port configuration:

```
Router (config)# interface gigabitethernet0/0/2
Router (config-if)# service instance 10 Ethernet
Router (config-if-srv)# encapsulation dot1q 20 second dot1q 30
Router (config-if-srv)# rewrite ingress tag pop 2 symmetric
Router (config-if-srv)# bridge-domain 10
```

- For 2-to-1 VLAN translation (EFP to EFP), ingress port configuration:

```
Router (config)# interface gigabitethernet0/0/1
Router (config-if)# service instance 10 Ethernet
Router (config-if-srv)# encapsulation dot1q 10 second-dot1q 20
Router (config-if-srv)# rewrite ingress tag pop 2 symmetric
Router (config-if-srv)# bridge-domain 10
```

Egress port configuration:

```
Router (config)# interface gigabitethernet0/0/2
Router (config-if)# service instance 10 Ethernet
Router (config-if-srv)# encapsulation dot1q 30
Router (config-if-srv)# rewrite ingress tag pop 1 symmetric
Router (config-if-srv)# bridge-domain 10
```

- For 2-to-2 VLAN translation (EFP to EFP), ingress port configuration:

```
Router (config)# interface gigabitethernet0/0/1
Router (config-if)# service instance 10 Ethernet
Router (config-if-srv)# encapsulation dot1q 10 second-dot1q 20
Router (config-if-srv)# rewrite ingress tag pop 2 symmetric
Router (config-if-srv)# bridge-domain 10
```

Egress port configuration:

```
Router (config)# interface gigabitethernet0/0/2
Router (config-if)# service instance 10 Ethernet
Router (config-if-srv)# encapsulation dot1q 30 second-dot1q 40
Router (config-if-srv)# rewrite ingress tag pop 2 symmetric
Router (config-if-srv)# bridge-domain 10
```

Example for Ingress Mapping of C-CoS to S-CoS

S-CoS is marked with the S-CoS value when the packet is matched with the C-CoS value at ingress. In the following example, GigabitEthernet 0/0/1 is the ingress interface and GigabitEthernet 0/0/3 is the egress interface. This classification is done at the ingress interface and the S-CoS value is set at 4.

```
policy-map policy-dscp
class class-dscp/customer-cos
set cos 4

interface GigabitEthernet0/0/1-> Input interface with EVC Push and policy on EVC
service instance 1 ethernet
encapsulation untagged
rewrite ingress tag push dot1q 10
service-policy input policy-dscp
bridge-domain 20

interface GigabitEthernet0/0/3
service instance 1 ethernet
encapsulation dot1q 30
bridge-domain 20
```

Example for Ingress Mapping of C-CoS to C-CoS

In the following example, both C-CoS and S-CoS are configured with CoS=4. The example also illustrates the ingress mapping of C-DSCP or C-CoS to C-CoS, where CoS is marked for both S-CoS and C-CoS.

```

policy-map policy-dscp
class class-dscp/customer-cos
set cos 4          -> This sets the value of S-CoS.

interface GigabitEthernet0/1    ->Input interface with EVC Push and EVC policy
service instance 1 ethernet
 encapsulation untagged
 rewrite ingress tag push dot1q 10
 service-policy input policy-dscp
 bridge-domain 20

interface GigabitEthernet0/3
service instance 1 ethernet
 encapsulation dot1q 30
 rewrite ingress tag pop1 symmetric
 bridge-domain 20

```

Example for Egress Classification Based on CoS

```

interface GigabitEthernet0/1    -> Input interface with EVC Push and EVC policy
service instance 1 ethernet
 encapsulation untagged
 rewrite ingress tag push dot1q 10
 service-policy input set-cos
 bridge-domain 20

interface GigabitEthernet0/3
service instance 1 ethernet
 encapsulation dot1q 30
 service-policy output policy-dscp
 bridge-domain 20

```

Layer 2 Protocol Tunneling

Customers at different sites connected across a service-provider network need to use various Layer 2 protocols to scale their topologies to include all remote sites, as well as the local sites. STP must run properly, and every VLAN should build a proper spanning tree that includes the local site and all remote sites across the service-provider network. Cisco Discovery Protocol (CDP) must discover neighboring Cisco devices from local and remote sites.

VLAN Trunking Protocol (VTP) must provide consistent VLAN configuration throughout all sites in the customer network that are participating in VTP. Similarly, DTP, LACP, LLDP, PAgP, and UDLD can also run across the service-provider network.

When protocol tunneling is enabled, edge switches on the inbound side of the service-provider network encapsulate Layer 2 protocol packets with a special MAC address (0100.0CCD.CDD0) and send them across the service-provider network. Core switches in the network do not process these packets but forward them as normal (unknown multicast data) packets. Layer 2 protocol data units (PDUs) for the configured protocols cross the service-provider network and are delivered to customer switches on the outbound side of the service-provider network. Identical packets are received by all customer ports on the same VLANs with these results:

- Users on each of a customer's sites can properly run STP, and every VLAN can build a correct spanning tree based on parameters from all sites and not just from the local site.
- CDP discovers and shows information about the other Cisco devices connected through the service-provider network.
- VTP provides consistent VLAN configuration throughout the customer network, propagating to all switches through the service provider that support VTP.

Customers use Layer 2 protocol tunneling to tunnel BPDUs through a service-provider network without interfering with internal provider network BPDUs.



Note Layer 2 protocol tunneling is supported on EFPs, but not on switchports. Layer 2 protocol tunneling is not supported on cross-connect EFPs.

In figure below, Customer X has four switches in the same VLAN, which are connected through the service-provider network. If the network does not tunnel PDUs, switches on the far ends of the network cannot properly run STP, CDP, and other Layer 2 protocols. For example, STP for a VLAN on a switch in Customer X, Site 1, will build a spanning tree on the switches at that site without considering convergence parameters based on Customer X's switch in Site 2. This could result in the topology shown in figure below.

Figure 1: Layer 2 Protocol Tunneling

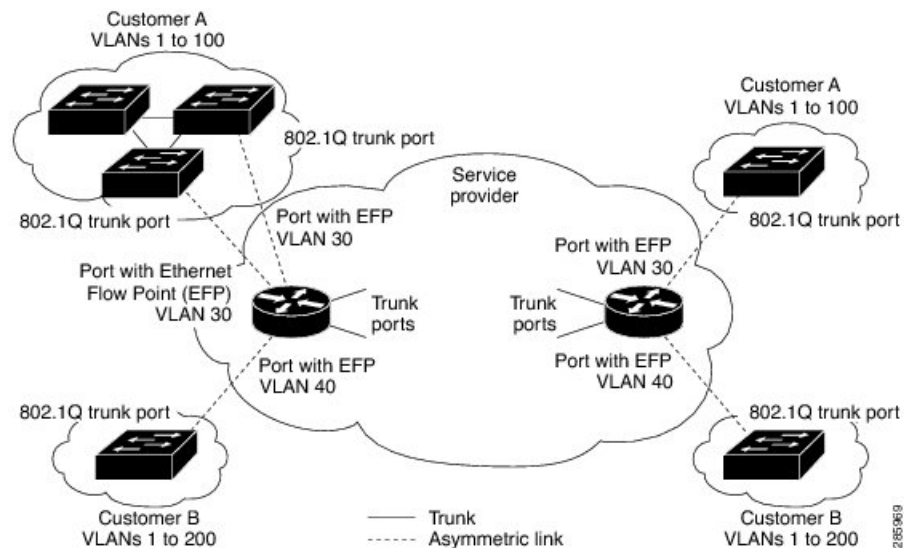
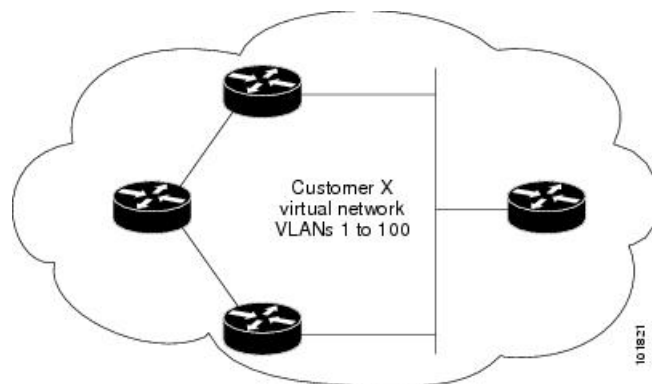

Figure 2: Layer 2 Network Topology without Proper Convergence



In a service-provider network, you can use Layer 2 protocol tunneling to enhance the creation of EtherChannels by emulating a point-to-point network topology. When you enable protocol tunneling (PAgP or LACP) on the service-provider switch, remote customer switches receive the PDUs and can negotiate the automatic creation of EtherChannels.

For example, in figure below, Customer A has two switches in the same VLAN that are connected through the SP network. When the network tunnels PDUs, switches on the far ends of the network can negotiate the automatic creation of EtherChannels without needing dedicated lines.

Figure 3: Layer 2 Protocol Tunneling for EtherChannels

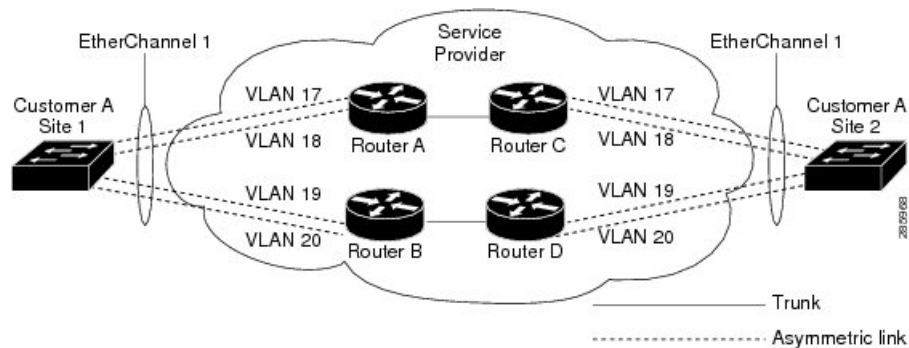

Use the **`l2protocol tunnel protocol service-instance`** configuration command to enable Layer 2 protocol tunneling on a service instance:

Valid protocols include CDP, LACP, LLDP, PAgP, STP, UDLD, and VTP. If a protocol is not specified for a service instance, the protocol frame is dropped at the interface.

This is an example of Layer 2 protocol tunneling configuration:

```
Router (config)# interface gigabitethernet0/0/2
Router (config-if)# service instance 10 Ethernet
Router (config-if-srv)# encapsulation untagged, dot1q 200 second-dot1q 300
Router (config-if-srv)# l2protocol tunnel cdp stp vtp dtp pagp lacp
Router (config-if-srv)# bridge-domain 10
```



Note To enable tunneling of most Layer 2 protocol, you must configure **encapsulation untagged** because Layer 2 protocol PDUs are usually untagged.

Layer 2 protocol tunneling statistics

The following command is used to view the Layer 2 protocol tunneling statistics:

show ethernet service instance id *service-instance id* *interface interface* platform.

This is an example of Layer 2 protocol tunneling statistics:

```
2020#sh run int gi0/0/9
Building configuration...

Current configuration : 228 bytes
interface GigabitEthernet0/0/9
  no ip address
  media-type auto-select
  negotiation auto
  no keepalive
  service instance 200 ethernet
  encapsulation untagged
  l2protocol tunnel
  xconnect 2.2.2.2 1 encapsulation mpls
end

2020#show ethernet service instance id 200 inter gig 0/0/9 platform

Service Instance (EFP) L2 PDU Handling Info

EFP          CDP   STP   VTP   DTP   PAGP  LLDP  LACP  UDLD  LOAM  ESMC  ELMI  PTPPD
RES4 RES5 RES6 RES8 RES9 RESA RESB RESC RESD RESF CFG  NH
-----
Gi0/0/9.Efp200  TUNL TUNL TUNL DROP TUNL TUNL TUNL TUNL TUNL TUNL TUNL TUNL TUNL
TUNL TUNL TUNL TUNL TUNL TUNL TUNL TUNL TUNL TUNL Y  N

EFP L2PT Tunnel statistics
-----
L2protocol      Encapped      Decapped
-----
CDP:              0              0
STP:             4059           13661
VTP:              0              0
DTP:              0              0
PAGP:             0              0
LLDP:             0              0
LACP:             0              0
UDLD:             0              0
LOAM:             0              0
ESMC:             0              0
ELMI:             0              0
PTPPD:           0              0
```



Note Layer 2 Protocol Tunnel decap statistics increments on core port for Layer 2 Protocol Tunnel over BD/VPLS scenario and Layer 2 Protocol Tunnel.

EFPs and Ethernet over Multiprotocol Layer Switching (EoMPLS)

When you configure a pseudowire under a VLAN interface (for example, VLAN 33), the pseudowire becomes a virtual Layer 2 port in that VLAN (VLAN 33), or bridge domain. In this bridge domain, you can configure other types of Layer 2 ports, such as EFP ports. Switching functionalities, such as MAC address learning, flooding, and forwarding to learned MAC addresses, apply to all the Layer 2 ports, including the pseudowire.



Note When a pseudowire is present in the same bridge domain as an EFP, you cannot configure the EFP with the **rewrite ingress tag pop 2 symmetric** service instance configuration command. Other restrictions about switching between EFPs or between EFPs also still apply.

For more information about configuring pseudowire, see the [Cisco NCS 4200 Series Software Configuration Guide](#).

Bridge Domain Routing

The switch supports IP routing and multicast routing for bridge domains, including Layer 3 and Layer 2 VPNs, using the BDI model. There are the limitations:

- You must configure BDIs for bridge-domain routing.
- The bridge domain must be in the range of 1 to 4094 to match the supported VLAN range.
- You can use bridge domain routing with only native packets.

This is an example of configuring bridge-domain routing with a single tag EFP:

```
Router (config)# interface gigabitethernet0/0/2
Router (config-if)# service instance 1 Ethernet
Router (config-if-srv)# encapsulation dot1q 10
Router (config-if-srv)# rewrite ingress tag pop 1 symmetric
Router (config-if-srv)# bridge-domain 100
```

```
Router (config)# interface bdi 100
Router (config-if)# ip address 20.1.1.1 255.255.255.255
```

This is an example of configuring bridge-domain routing with two tags:

```
Router (config)# interface gigabitethernet0/0/2
Router (config-if)# service instance 1 Ethernet
Router (config-if-srv)# encapsulation dot1q 10 second-dot1q 20
Router (config-if-srv)# rewrite ingress tag pop 2 symmetric
Router (config-if-srv)# bridge-domain 100
```

```
Router (config)# interface bdi 100
Router (config-if)# ip address 20.1.1.1 255.255.255.255
```

EFPs and Trunk Port MAC Addresses

Because forwarding can occur between EFPs and trunk ports, MAC address movement can occur on learned addresses. Addresses learned on EFPs will have the format of interface + EFP ID, for example gigabitethernet 0/0/1 + EFP 1. When an address moves between a non-secured EFP and a trunk port, the behavior is similar to that of moving between trunk ports.

To see MAC address information for bridge domains, use the **show mac-address-table bdomain** *domain* command.

When an EFP property changes (bridge domain, rewrite, encapsulation, split-horizon, secured or unsecured, or a state change), the old dynamic MAC addresses are flushed from their existing tables. This is to prevent old invalid entries from lingering.

EFPs and MSTP

EFP bridge domains are supported by the Multiple Spanning Tree Protocol (MSTP). These restrictions apply when running STP with bridge domains.

- EVC supports only MSTP.
- All incoming VLANs (outer-most or single) mapped to a bridge domain must belong to the same MST instance or loops could occur.
- For all EFPs that are mapped to the same MST instance, you must configure backup EFPs on every redundant path to prevent loss of connectivity due to STP blocking a port.

L3 Unicast and Multicast Routing on a Bridge Domain with Multiple EFPs

L3 unicast routing and L3 multicast routing are supported on bridge domains with multiple EFPs. This feature provides the following functionality:

- Broadcast domains are determined through bridge-domains rather than VLANs
- Multiple EFPs on a single bridge domain and physical interface with L3 multicast routing enabled is supported
- Each EFP has its own match criteria and its own ingress and egress rewrite operations

Figure below shows an access-facing port with multiple EFPs configured to the route or bridge.

Example for Configuring L3 Multicast Routing on a Bridge Domain

The following example shows how to configure L3 multicast routing on a bridge domain using existing IOS commands.

```
ip routing
Ip multicast-routing
!
!
interface bdi 100
    ip address 1.1.1.1 255.255.255.0
    ip pim sparse-mode
    Icmp version v3
!
interface GigabitEthernet0/1
    service instance 1 ethernet
    encapsulation dot1q 33
    rewrite ingress tag pop 1 symmetric
    bridge-domain 100
!
service instance 2 ethernet
    encapsulation dot1q 55
    rewrite ingress tag pop 1 symmetric
    bridge-domain 100
```

Cross-Connect on EFP Interfaces

Cross-connect provides the ability to match the encapsulation of received packets on the ingress side of an EFP interface and send them out with the same encapsulation through the egress side of the EFP interface. Cross-connect bridge-domain entries are provided, and encapsulation matching is achieved by matching bridge-domain entries for the EFPs on which cross-connect is configured.

The following types of encapsulation tags are supported:

- untagged
- rewrite tags with pop1

Restrictions

- A bridge-domain cannot be configured on an EFP if cross-connect is already configured.
- Cross-connect works only when the MPLS license is enabled.
- Priority-tagged encapsulation is not supported.
- L2VPN VC statistics are not supported on the RSP3 module.

Configuring Cross-Connect on an EFP Interface

Beginning in privileged EXEC mode, follow these steps to configure cross-Connect on an EFP Interface.

SUMMARY STEPS

1. **configure terminal**
2. **interface** *interface-id*
3. **service instance** *number* **ethernet** [*name*]
4. **encapsulation dot1q** *vlan_id* **cos** *cos_value* **second-dot1q** *vlan-id* **cos** *cos_value*
5. **xconnect** *peer-router-id* *vcid* **pw-class** *pw-class name*
6. **end**

DETAILED STEPS

	Command or Action	Purpose
Step 1	configure terminal	Enter global configuration mode.
Step 2	interface <i>interface-id</i>	Specify an interface to configure, and enter interface configuration mode.
Step 3	service instance <i>number</i> ethernet [<i>name</i>]	Configure an EFP (service instance) and enter service instance configuration mode. <ul style="list-style-type: none"> • The number is the EFP identifier, an integer from 1 to 4000. • (Optional) ethernet name is the name of a previously configured EVC. You do not need to use an EVC name in a service instance.

	Command or Action	Purpose
Step 4	<code>encapsulation dot1q vlan_id cos cos_value second-dot1q vlan-id cos cos_value</code>	CoS value encapsulation defines match criterion after including the CoS for the S-Tag and the C-Tag. The CoS value is a single digit between 1 and 7 for S-Tag and C-Tag. You cannot configure CoS encapsulation with <code>encapsulation untagged</code> . The result is an exact outermost VLAN and CoS match and second tag. You can also use VLAN ranges.
Step 5	<code>xconnect peer-router-id vcid pw-class pw-class name</code>	Bind the attachment circuit to a pseudowire virtual circuit (VC) and enter xconnect configuration mode.
Step 6	<code>end</code>	Return to privileged EXEC mode. This is an example configuration of cross-connect on an EFP interface: <pre>interface gigabitethernet 0/0/3 service instance 30 ethernet encap dot1q x second dot1q y xconnect <10.10.10.10> 123 encapsulation mpls</pre>

MAC Address Forwarding, Learning and Aging on EFPs

- Layer 2 forwarding is based on the bridge domain ID and the destination MAC address. The frame is forwarded to an EFP if the binding between the bridge domain, destination MAC address, and EFP is known. Otherwise, the frame is flooded to all the EFPs or ports in the bridge domain.
- MAC address learning is based on bridge domain ID, source MAC addresses, and logical port number. MAC addresses are managed per bridge domain when the incoming packet is examined and matched against the EFPs configured on the interface. If there is no EFP configured, the bridge domain ID equal to the outer-most VLAN tag is used as forwarding and learning look-up key.

If there is no matching entry in the Layer 2 forwarding table for the ingress frame, the frame is flooded to all the ports within the bridge domain. Flooding within the bridge domain occurs for unknown unicast, unknown multicast, and broadcast.

- Dynamic addresses are addresses learned from the source MAC address when the frame enters the router. All unknown source MAC addresses are sent to the CPU along with ingress logical port number and bridge domain ID for learning. Once the MAC address is learned, the subsequent frame with the destination MAC address is forwarded to the learned port. When a MAC address moves to a different port, the Layer 2 forwarding entry is updated with the corresponding port.



Note The Cisco router does not currently support the `no mac address-table learning bridge-domain bridge-id` global configuration command.

- Dynamic addresses are aged out if there is no frame from the host with the MAC address. If the aged-out frame is received by the switch, it is flooded to the EFPs in the bridge domain and the Layer 2 forwarding entry is created again. The default for aging dynamic addresses is 5 minutes. However, when MST

undergoes a topology change, the aging time is reduced to the *forward-delay* time configured by the spanning tree. The aging time reverts back to the last configured value when the topology change expires.

You can configure a dynamic address aging time per bridge domain using the **mac aging-time time** command. The range is in seconds and valid values are 120-360. The default value is 300. An aging time of 0 means that the address aging is disabled.

- MAC address movement is detected when the host moves from one port to another. If a host moves to another port or EFP, the learning lookup for the installed entry fails because the ingress logical port number does not match and a new learning cache entry is created. The detection of MAC address movement is disabled for static MAC addresses where the forwarding behavior is configured by the user.

Configuring a Static MAC Address

This section describes how to configure a static MAC address. For an overview of static MAC addresses, see [Static MAC Addresses](#).

Limitations

The following limitations apply when configuring static MAC addresses:

- Static MAC addresses are supported only on egress ports.
- You can configure up to 1024 multicast static MAC addresses
- You can assign up to 24 EFPs to a bridge domain configured with a multicast static MAC address.
- MAC entries configured across different bridge-domains are represented as separate entries in the router MAC table.
- Multicast static MAC addresses apply only to layer 2 traffic; layer 3 multicast traffic is not affected by a static MAC configuration and is forwarded to all EFPs in a bridge domain.

Configuring a Multicast Static MAC Address

SUMMARY STEPS

1. **configure terminal**
2. **interface** *interface-id*
3. **service instance** *number* **ethernet** [*name*]
4. **encapsulation** {**default** | **dot1q** | **priority-tagged** | **untagged**}
5. **bridge-domain** *bridge-id* [**split-horizon group** *group-id*]
6. **mac static address** *address*
7. **end**

DETAILED STEPS

	Command or Action	Purpose
Step 1	configure terminal Example: Router# configure terminal	Enter global configuration mode.
Step 2	interface <i>interface-id</i> Example: Router(config)# interface gigabitethernet 0/3/6	Specify the port to attach to the policy map, and enter interface configuration mode. Valid interfaces are physical ports.
Step 3	service instance <i>number</i> ethernet [<i>name</i>] Example: Router(config)# service instance 1 ethernet	Configure an EFP (service instance) and enter service instance configuration) mode. <ul style="list-style-type: none"> • The number is the EFP identifier, an integer from 1 to 4000. • (Optional) ethernet name is the name of a previously configured EVC. You do not need to use an EVC name in a service instance.
Step 4	encapsulation {default dot1q priority-tagged untagged} Example: Router(config-if-srv)# encapsulation dot1q 1	Configure encapsulation type for the service instance. <ul style="list-style-type: none"> • default—Configure to match all unmatched packets. • dot1q—Configure 802.1Q encapsulation. See Table 1: Supported Encapsulation Types for details about options for this keyword. • priority-tagged—Specify priority-tagged frames, VLAN-ID 0 and CoS value of 0 to 7. • untagged—Map to untagged VLANs. Only one EFP per port can have untagged encapsulation.
Step 5	bridge-domain <i>bridge-id</i> [split-horizon group <i>group-id</i>] Example: Router(config-if-srv)# bridge-domain 1	Configure the bridge domain ID. The range is from 1 to 4000. You can use the split-horizon keyword to configure the port as a member of a split horizon group. The <i>group-id</i> range is from 0 to 2.
Step 6	mac static address <i>address</i> Example: Router(config-if-srv)# mac static address 1302.4302.23c3	Specifies the multicast MAC address.
Step 7	end Example: Router(config-if-srv)# end	Return to privileged EXEC mode.

Configuration Example

This is an example configuration of a static MAC address on an EFP interface:

```
interface gigabitEthernet 0/0/3
  service instance 10 ethernet
  encapsulation dot1q 10
  bridge-domain 100
  mac static address 1302.4302.23c3
```

This configuration specifies that any layer 2 traffic sent to destination MAC address 1302.4302.23c3 is forwarded only to service instance 10 of bridge-domain interface Gigabit Ethernet 0/0/3.

To disable a static MAC configuration, apply the **mac static address** *address* command to the service instance:

```
Router (config)# interface gigabitEthernet0/0/1
Router (config-if)# service instance 1 Ethernet
Router (config-if-srv)# mac static address 1302.4302.23c3
```

Monitoring EVC

Table 4: Supported show Commands

	Description
show ethernet service evc [<i>id evc-id</i> interface <i>interface-id</i>] [detail]	Displays information about all EVCs, or a specific EVC when you enter an EVC ID, or all EVCs on an interface when you enter an interface ID. The detail option provides additional information about the EVC.
show ethernet service instance [<i>id instance-id</i> interface <i>interface-id</i> interface <i>interface-id</i>] {[detail] [<i>stats</i>]}	Displays information about one or more service instance (EFPs). If you specify an EFP ID and interface, only data pertaining to that particular EFP is displayed. If you specify only an interface ID, data is displayed for all EFPs on the interface.
show bridge-domain [<i>n</i>]	When you enter <i>n</i> , this command displays all the members of the specified bridge-domain, if a bridge-domain with the specified number exists. If you do not enter <i>n</i> , the command displays all the members of all bridge-domains in the system.
show bridge-domain <i>n</i> split-horizon [group { <i>group-id</i> all }]	When you do not specify a group <i>group-id</i> , this command displays all the members of bridge-domain <i>n</i> that belong to split horizon group 0. If you specify a numerical <i>group-id</i> , this command displays all the members of the specified group id. When you enter group all , the command displays all members of any split horizon group.

	Description
show ethernet service instance detail	This command displays detailed service instance information, including Layer 2 protocol information. This is an example of the output: Router# show ethernet service instance detail Service Instance ID: 1 Associated Interface: Ethernet0/0 Associated EVC: L2protocol tunnel pagp CE-Vlans: State: Up EFP Statistics: Pkts In Bytes In Pkts Out Bytes Out 0 0 0 0
show mac address-table	This command displays dynamically learned or statically configured MAC security addresses.
show mac address-table bridge-domain <i>bridge-domain id</i>	This command displays MAC address table information for the specified bridge domain.
show mac address-table count bridge-domain <i>bridge-domain id</i>	This command displays the number of addresses present for the specified bridge domain.
show mac address-table learning bridge-domain <i>bridge-domain id</i>	This command displays the learning status for the specified bridge domain.

This is an example of output from the **show ethernet service instance detail** command:

```
Router# show ethernet service instance id 1 interface gigabitEthernet 0/0/1 detail
Service Instance ID: 1
Associated Interface: GigabitEthernet0/0/13
Associated EVC: EVC_P2P_10
L2protocol drop
CE-Vlans:
Encapsulation: dot1q 10 vlan protocol type 0x8100
Interface Dot1q Tunnel Ethertype: 0x8100
State: Up
EFP Statistics:
    Pkts In   Bytes In   Pkts Out   Bytes Out
          214   15408    97150   6994800
EFP Microblocks:
*****
Microblock type: Bridge-domain
Bridge-domain: 10
```

This is an example of output from the **show bridge-domain** command:

```
Router# show bridge-domain 100
Bridge-domain 100 (1 ports in all)
State: UP Mac learning: Enabled
Aging-Timer: 300 second(s)
Maximum address limit: 256000
GigabitEthernet0/0/0 service instance 1
```



```
Nile Mac Address Entries
```

```
BD mac addr type ports
```

```
-----  
100 0000.bbbb.cccc STATIC Gi0/0/0.Efp1
```

```
sh mac-address-table bdomain 100
```

```
Nile Mac Address Entries
```

```
BD mac addr type ports
```

```
-----  
100 0000.bbbb.cccc STATIC Gi0/0/0.Efp1
```

This is an example of output from the **show ethernet service instance** statistics command:

```
Router# show ethernet service instance id 1 interface gigabitEthernet 0/0/13 stats  
Service Instance 1, Interface GigabitEthernet0/0/13  
Pkts In   Bytes In   Pkts Out  Bytes Out  
    214     15408     97150    6994800
```

This is an example of output from the **show mac-address table count** command:

```
Router# show mac address-table count bridge-domain 10
```

```
Mac Entries for BD 10:
```

```
-----  
Dynamic Address Count : 20  
Static Address Count  : 0  
Total Mac Addresses   : 20
```

