



## Layer 2 Ethernet over GRE

---

Ethernet over Soft Generic Routing Encapsulation (EoGRE) is an aggregation solution for aggregating WiFi traffic from hotspots. This solution enables customer premises equipment (CPE) devices to bridge the Ethernet traffic from an end host, and encapsulates the traffic in Ethernet packets over an IP GRE tunnel. The IP GRE tunnel terminates on a service provider broadband network gateway, which then terminates the end host traffic and manages the subscriber session for the end host.

- [Finding Feature Information, on page 1](#)
- [Restrictions for Layer 2 Ethernet over GRE, on page 1](#)
- [Information About Layer 2 Ethernet over GRE, on page 2](#)
- [Configuration Example: Two-box Deployment Model, on page 3](#)
- [Additional References, on page 3](#)
- [Feature Information for Layer 2 Ethernet over GRE, on page 4](#)

### Finding Feature Information

Your software release may not support all the features documented in this module. For the latest caveats and feature information, see [Bug Search Tool](#) and the release notes for your platform and software release. To find information about the features documented in this module, and to see a list of the releases in which each feature is supported, see the feature information table.

Use Cisco Feature Navigator to find information about platform support and Cisco software image support. To access Cisco Feature Navigator, go to <https://cfng.cisco.com/>. An account on Cisco.com is not required.

### Restrictions for Layer 2 Ethernet over GRE

- Transport on IPv6 is not supported.
- Virtual Ethernet interface does not support encapsulation untagged.
- L2 EoGRE is only supported on Cisco ASR 1000 routers. It is not supported on Cisco CSR1000V or Cisco 4000 Series ISR routers.
- Multicast traffic is not supported.

# Information About Layer 2 Ethernet over GRE

The ASR 1000 platform services as the SP broadband network gateway which:

- Terminates the IP GRE tunnel, and/or
- Manages the subscriber session for the end-host client.

**Figure 1: Ethernet over Soft GRE Deployment**

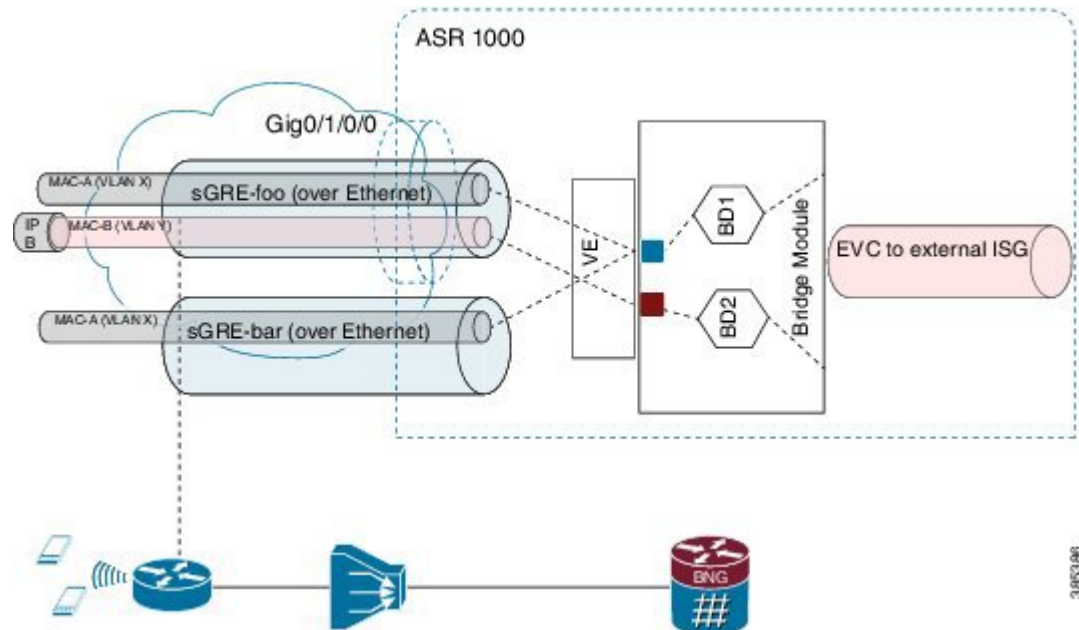

The deployment model that is supported is the two-box model:

- In the two-box model, the ASR 1000 router provides only the functionality to terminate the bridged Ethernet over soft GRE traffic. The ISG subscriber management resides in an external router which is connected with the router using L2 bridge-domain.

The major components involved in L2 EoGRE are:

- Virtual Ethernet interface.
- Ethernet service instance.
- IP GRE tunnel data plane.
- L2 bridge-domain data plane.

**Control Plane**—After the Virtual Ethernet interface is configured, the Virtual Ethernet interface is downloaded to the ASR 1000 platform as a virtual interface.

Service instances (EVCs) are configured under the virtual ethernet interface and are downloaded to ASR1K platform. The service instances are then propagated in the ASR 1000 platform to fman-rp, fman-fp, cpp-client and cpp dataplane, where the EVC feature invocation arrays (FIAs) are enabled.

**Data Plane**—When receiving the IP GRE encapsulated Ethernet packet, the data plane tunnel ingress processing checks the protocol field in the GRE header. If the protocol is transparent Ethernet bridging protocol (0x6558), the packet is identified as Ethernet over soft GRE packet and is directed to the Ethernet service instance classification module. The Ethernet service instance classification module classifies the packet into the service instance configured under the Virtual Ethernet interface using the VLAN tag in the packet. After the Ethernet service instance is identified, the packet goes through the programmed processing FIA under the Ethernet service instance such as vlan tag manipulation and is then sent to L2 bridge domain for further processing. At the L2 bridge domain processing module, the client source MAC address is dynamically learned, and so is the IP GRE tunnel end-points. As a result, the MAC address table contains the IP GRE tunnel end-points for the client MAC address.

The packet is then either bridged to the external ISG for subscriber processing in the case of the two-box deployment model. In the direction where the ISG, either external or internal, sends a packet to the mobile client, the L2 bridge domain looks up the destination MAC address using the L2 bridge domain MAC address table. Once the result is found, the IP GRE tunnel end point addresses are also retrieved from the MAC address table. The L2 Ethernet packet is then encapsulated into the IP GRE tunnel using the retrieved tunnel end point address. Once encapsulated into the IP GRE packet, IP lookup is then performed and the packet is sent to the CPE.

## Configuration Example: Two-box Deployment Model

```
Interface GigabitEthernet0/0/0
  description Connect-Internet-Gateway
  no ip address
  negotiation auto
  service instance 140 Ethernet
    encapsulation dot1q 140
    bridge-domain 140

Interface Virtual-Ethernet1
  description L2 EoGRE Tunnel
  arp timeout 0
  service instance 140 Ethernet
    encapsulation dot1q 140
    rewrite egress tag translate 1-to-1 dot1q 140
    bridge-domain 140
```

## Additional References

### Related Documents

Related Topic	Document Title
Configuration guide	<i>Cisco IOS Carrier Ethernet Configuration Guide</i> , Release 12.2SR
Carrier Ethernet commands: complete command syntax, command mode, command history, defaults, usage guidelines, and examples	<i>Cisco IOS Carrier Ethernet Command Reference</i>

**Standards**

Standard	Title
None	--

**MIBs**

MIB	MIBs Link
None	To locate and download MIBs for selected platforms, Cisco software releases, and feature sets, use Cisco MIB Locator found at the following URL:  <a href="http://www.cisco.com/go/mibs">http://www.cisco.com/go/mibs</a>

**RFCs**

RFC	Title
None	--

**Technical Assistance**

Description	Link
The Cisco Support and Documentation website provides online resources to download documentation, software, and tools. Use these resources to install and configure the software and to troubleshoot and resolve technical issues with Cisco products and technologies. Access to most tools on the Cisco Support and Documentation website requires a Cisco.com user ID and password.	<a href="http://www.cisco.com/cisco/web/support/index.html">http://www.cisco.com/cisco/web/support/index.html</a>

## Feature Information for Layer 2 Ethernet over GRE

The following table provides release information about the feature or features described in this module. This table lists only the software release that introduced support for a given feature in a given software release train. Unless noted otherwise, subsequent releases of that software release train also support that feature.

Use Cisco Feature Navigator to find information about platform support and Cisco software image support. To access Cisco Feature Navigator, go to [www.cisco.com/go/cfn](http://www.cisco.com/go/cfn). An account on Cisco.com is not required.

**Table 1: Feature Information for Layer 2 Ethernet over GRE**

<b>Feature Name</b>	<b>Releases</b>	<b>Feature Information</b>
Layer 2 Ethernet over GRE	Cisco IOS XE Release 3.9S	Ethernet over Soft Generic Routing Encapsulation (EoGRE) is an aggregation solution for aggregating WiFi traffic from hotspots. This solution enables customer premises equipment (CPE) devices to bridge the Ethernet traffic from an end host, and encapsulates the traffic in Ethernet packets over an IP GRE tunnel. The IP GRE tunnel terminates on a service provider broadband network gateway, which then terminates the end host traffic and manages the subscriber session for the end host.

