

# Microsoft Azure Local Connectivity to Cisco Nexus 9000 Series Switches in Cisco NX-OS and Cisco® Application Centric Infrastructure (Cisco ACI™) Mode

## Contents

Introduction .....	5
<b>Prerequisites</b> .....	<b>5</b>
<b>Terminologies</b> .....	<b>5</b>
Executive Summary .....	6
<b>Document Purpose</b> .....	<b>7</b>
<b>Technology Overview</b> .....	<b>7</b>
About Cisco ACI .....	7
Cisco ACI Architecture .....	8
Cisco Nexus 9000 NX-OS based Fabric .....	9
Solution Design.....	10
<b>Physical Architecture</b> .....	<b>10</b>
<b>Logical Architecture</b> .....	<b>11</b>
<b>Cisco Nexus 9000 Series Switch based Fabric and Benefit</b> .....	<b>16</b>
<b>Cisco ACI Design for Azure Local Connectivity</b> .....	<b>17</b>
Cisco ACI for Azure Local Connectivity .....	17
Azure Local ACI Tenant Model Overview.....	19
<b>Cisco NX-OS based Fabric Design for Azure Local Connectivity</b> .....	<b>19</b>
Cisco NX-OS based Fabric for Azure Local Connectivity.....	20
Solution Deployment.....	21
<b>Cisco ACI Configuration for Azure Local</b> .....	<b>21</b>
Configuring Leaf Interfaces Connected to Azure Local Servers .....	21
Configure QoS .....	33
Configure EPGs .....	40
<b>Cisco NX-OS based Fabric configuration for Azure Local</b> .....	<b>47</b>
Configure QoS .....	47
Configure LLDP .....	52
Configure Networks for Azure Local.....	52
Build External Connectivity for Azure Local servers.....	58
Appendix .....	59
<b>Design Example with Microsoft Software Defined Networking (SDN) in Azure Local</b> .....	<b>59</b>
Microsoft Azure SDN Components .....	59
Logical Architecture.....	60
Cisco ACI Design for PA Network and SLB Connectivity .....	61
Cisco ACI Design for Azure Local VNET Connectivity.....	62
Logical Network .....	Error! Bookmark not defined.
Azure Local VNET Connectivity .....	Error! Bookmark not defined.
Solution Deployment.....	64

<b>Cisco ACI Configuration for PA Network and SLB Connectivity .....</b>	<b>70</b>
<b>Cisco ACI Configuration for Azure Local VNET &amp; Gateway VM Connectivity .....</b>	<b>82</b>
<b>Cisco NX-OS based Fabric Design .....</b>	<b>Error! Bookmark not defined.</b>
For more information .....	89
Revision history.....	90

**Note:** This document contains material and data with multiple dependencies. The information may be updated as and when necessary and is subject to change without notice.

Privileged/Confidential information is contained in this document and may be subject to legal privilege. Access to this material by anyone other than those intended is unauthorized. If you are not the intended recipient (or responsible for delivery of the information to such person), you may not use, copy, distribute, or deliver to anyone this information (or any part of its contents) or take any action in reliance on it. In such case, you should destroy this information and notify Cisco immediately. If you have received this material in error, please notify us immediately and delete the material from any computer. If you or your employer does not consent to this message, please notify us immediately. Our company cannot accept responsibility for any loss or damage arising from the use of this material.

## Introduction

This document describes the network design considerations for Microsoft Azure Local, formerly known as Microsoft Azure Stack HCI, in a Cisco Nexus 9000 Series Switches-based network with Cisco NX-OS and Cisco® Application Centric Infrastructure (Cisco ACI™).

## Prerequisites

This document assumes that you have a basic knowledge of Cisco ACI and Cisco NX-OS VXLAN technologies.

For more information on Cisco ACI, refer to the white papers on Cisco.com:

<https://www.cisco.com/c/en/us/solutions/data-center-virtualization/application-centric-infrastructure/white-paper-listing.html>

For more information on Cisco NX-OS based VXLAN fabrics, refer to the white papers on Cisco.com:

<https://www.cisco.com/c/en/us/products/switches/nexus-9000-series-switches/white-paper-listing.html>

## Terminologies

- Cisco ACI related terminologies
  - BD: bridge domain
  - EPG: endpoint group
  - L3Out: Layer 3 Out or external routed network
  - L3Out EPG: subnet-based EPG in L3Out
  - VRF: Virtual Routing and Forwarding
  - Border leaf: ACI leaf where L3Out is deployed
- Cisco NX-OS related terminologies
  - NDFC: Nexus Dashboard Fabric Controller
  - VXLAN: Virtual Extensible LAN
  - VNI: Virtual Network Identifier (one to one co-relation between VLAN to VNI)
  - DAG: Distributed Anycast Gateway
  - Leaf: Performs VXLAN encapsulation and decapsulation function also referred as Virtual Tunnel End-Point (VTEP). End-hosts are connected to Leafs in the VXLAN fabric
  - Spine: Provides Underlay Layer-3 connectivity between the leafs in the VXLAN fabric
  - Border Leaf: Performs similar function to a Leaf. In addition, Border leafs connect the VXLAN fabric to external networks and are placed at the edge of the VXLAN fabric
  - External Connectivity: Provide L3 connectivity outside of the VXLAN fabric
- Microsoft Azure Local related terminologies
  - RDMA: Remote Direct Memory Access
  - RoCE: RDMA over Converged Ethernet
  - SET: Switch Embedded Teaming
  - SMB: Server Message Block
  - Storage Spaces Direct: A feature of the Microsoft Azure Local and Windows Server that enables you to cluster servers with an internal storage into a software-defined storage solution. Storage Spaces Direct uses SMB3, including SMB Direct and SMB Multichannel over Ethernet to communicate between servers

SMB Direct: The Windows Server includes a feature called SMB Direct, which supports the use of network adapters that have RDMA capability. Network adapters with RDMA capability can function at full speed with lower latency without compromising CPU utilization. SMB Direct requires network adapters with RDMA capability on the servers and RDMA over Converged Ethernet (RoCEv2) on the network

## Executive Summary

Beginning with Cisco ACI Release 6.0(3e) and NX-OS 10.3(2)F, Nexus 9000 Series Switches support the Microsoft [Azure Local requirements](#). This document details the Microsoft Azure Local network design with Cisco Nexus 9000 Series Switches in either Cisco ACI or Cisco NX-OS mode.

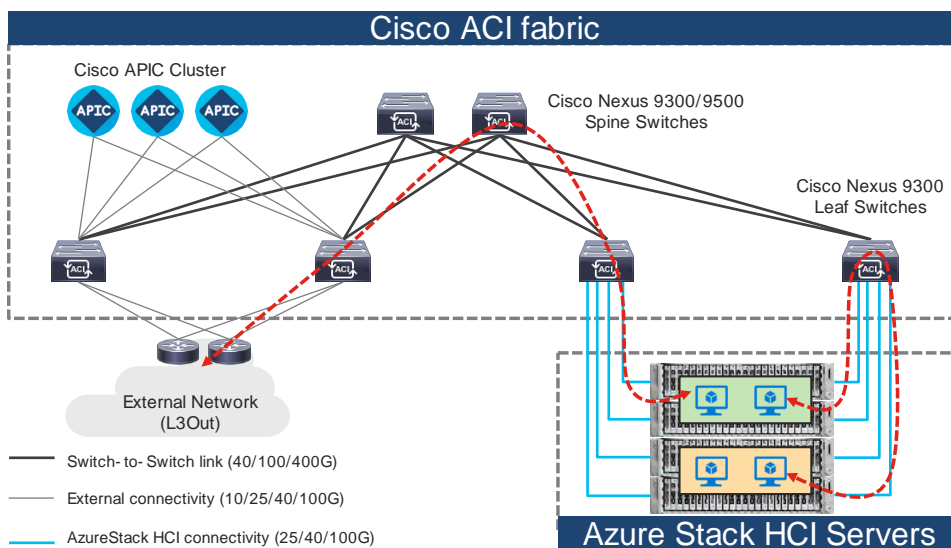

**Figure 1.** Topology example with Nexus 9000 Series Switches in Cisco ACI mode

**Note:** Cisco Application Policy Infrastructure Controller (APIC) can be connected to leaf switches directly or connected through the Layer 3 network via spine switches.

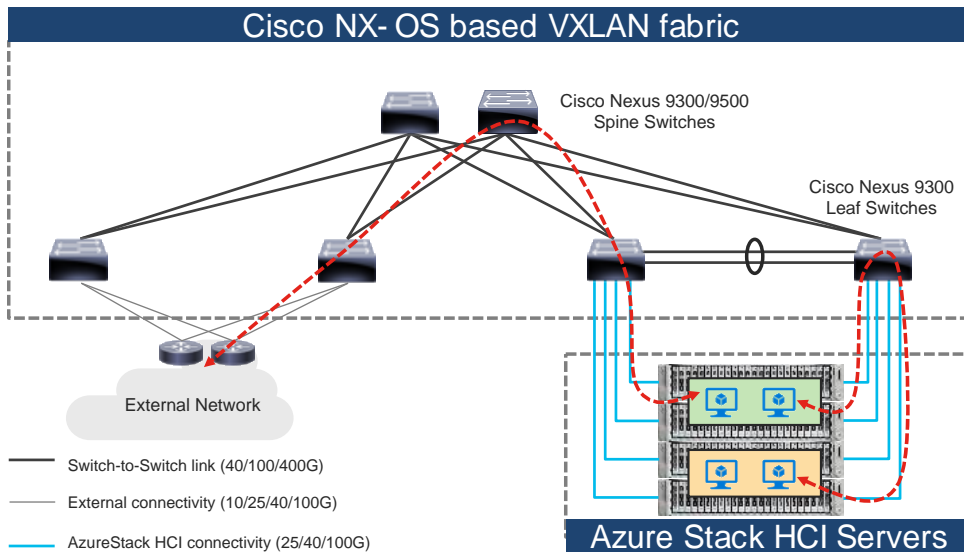

**Figure 2.** Topology example with Nexus 9000 Series Switches in Cisco NX-OS mode

## Document Purpose

You must ensure that there are direct connections from the Microsoft Azure Local servers to the Cisco Nexus 9000 Top-of-Rack (ToR) switches and accessibility to the data center among other required tasks, when installing the Microsoft Azure Local.

This document provides information, education, and guidance for connecting the Microsoft Azure Local servers to an existing Cisco Nexus 9000 Series Switch-based network in the data centers. The document provides fundamental information and recommended configurations based on internal testing of the solution. This document does not cover the installation and configuration of Cisco ACI or NX-OS based infrastructure nor does it detail the setup of Microsoft Azure Local.

This document uses Cisco UCS C240 M6/M7 servers as the Microsoft Azure Local servers. For Cisco UCS configuration and design considerations, refer to the Cisco Validated Design (CVD) on cisco.com: [https://www.cisco.com/c/en/us/td/docs/unified\\_computing/ucs/UCS\\_CVDs/ucs\\_mas\\_hci\\_m7.html](https://www.cisco.com/c/en/us/td/docs/unified_computing/ucs/UCS_CVDs/ucs_mas_hci_m7.html).

The Microsoft Azure Local internal networks are not managed using a Cisco controller such as Cisco APIC and NDFC in this solution. The Azure Local system is connected to the Nexus 9000 Series Switch-based network, which acts as the gateway to allow the Azure Local Virtual Machines (VM) to connect with other VMs, the external network, and other internal network services in the datacenter.

## Technology Overview

This section introduces the technologies that are used in the solution, which are described in this document.

### About Cisco ACI

Cisco ACI is an evolutionary leap from SDN's initial vision of operational efficiency through network agility and programmability. Cisco ACI has industry leading innovations in management automation, programmatic policies, and dynamic workload provisioning. The ACI fabric accomplishes this with a combination of hardware, policy-based control systems, and closely coupled software to provide advantages that are not possible in other architectures.

Cisco ACI takes a policy-based systems approach to operationalizing the data center network. The policy is centered around the needs (reachability, access to services, and security policies) of the applications. Cisco ACI delivers a resilient fabric to satisfy today's dynamic applications.

### Cisco ACI Architecture

The Cisco ACI fabric is a leaf-and-spine architecture where each leaf connects to every spine using high-speed 40/100/400-Gbps Ethernet links, with no direct connection between the spine switches or leaf switches. The ACI fabric is a routed fabric with a VXLAN overlay network, where every leaf is VXLAN Tunnel Endpoint (VTEP). Cisco ACI provides both Layer 2 (L2) and Layer 3 (L3) forwarding across this routed fabric infrastructure.

The following are the ACI fabric components:

**Cisco APIC:** Cisco Application Policy Infrastructure Controller (APIC) is the unifying point of automation and management for the Cisco ACI fabric. Cisco APIC is a centralized, clustered controller that provides centralized access to all fabric information, optimizes the application lifecycle for scale and performance, and supports flexible application provisioning across physical and virtual resources. Cisco APIC exposes northbound APIs through XML and JSON and provides both a command-line interface (CLI) and a GUI, which utilize the APIs to manage the fabric.

**Leaf Switches:** The ACI leaf provides physical connectivity for servers, storage devices, and other access layer components, and enforces the ACI policies. Leaf switches also provide connectivity to an existing enterprise or a service provider infrastructure. The leaf switches provide options starting at 1G up through 400G Ethernet ports for connectivity.

**Spine Switches:** In ACI, spine switches provide the mapping database function and connectivity between leaf switches. A spine switch can be the modular Cisco Nexus 9500 series equipped with ACI ready line cards or a fixed form-factor switch, such as the Cisco Nexus 9332D-GX2B. Spine switches provide high-density 40/100/400 Gigabit Ethernet connectivity to the leaf switches.

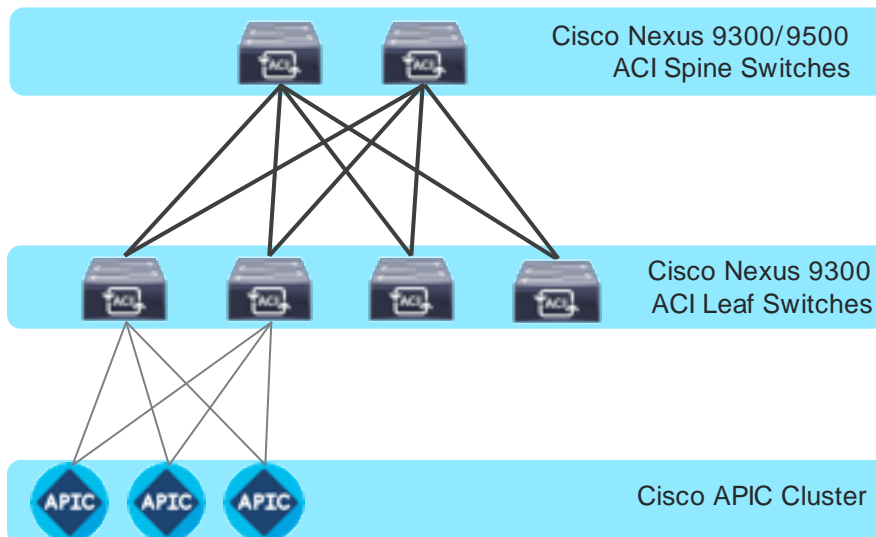

**Figure 3.**  
Cisco ACI Fabric Components



## Cisco Nexus 9000 NX-OS based Fabric

Cisco NX-OS based fabric is another option for building a data center by using the Nexus 9000 series switches. These switches act as independent devices and have their own control-plane and data-plane. Nexus 9000 series switches running NX-OS offer various data Center fabric options, such as VXLAN, L3 Routed or traditional (2-tier or 3-tier) LAN.

This document only focuses on connecting the Azure Local to the VXLAN fabric. However, NX-OS based L3 Routed or traditional LAN fabrics can also be used.

The following are the Cisco NX-OS based VXLAN fabric components:

**NDFC:** Cisco Nexus Dashboard Fabric Controller (NDFC) is an Orchestration and Automation tool to build and manage data center fabrics. Cisco NDFC can be used either in LAN or SAN mode. In LAN mode, NDFC supports various fabric templates to create VXLAN, VXLAN Multisite, L3 Routed Fabric, and traditional LAN and IP Fabrics for media. Cisco NDFC offers the following day 0 to day 2 operations:

- Day 0: Bootstrap (POAP) support for the devices and pre-provisioning of the fabrics.
- Day 1: Automation of new Greenfield fabrics as well as support for Brownfield fabrics, deployment for Networks & VRFs, and L4-L7 service insertion.
- Day 2: Image Management, RMA workflow, Change Control & Rollback, monitoring of devices health and interfaces.

Cisco NDFC is optional. A VXLAN fabric can also be managed through the traditional CLI. But using Cisco NDFC has its own advantages. As stated above Cisco NDFC provides full automation support for all types of data center fabrics by eliminating the chance for human errors.

**Nexus 9000 Series Switches:** Nexus 9000 switches are data center switches for a hybrid cloud networking foundation. The Cisco Nexus 9000 Series offers modular and fixed form-factors and can deliver 1Gig to 800 Gig of line-rate forwarding.

**VXLAN EVPN Fabric:** VXLAN EVPN is the de-facto standard of building large scale data center fabrics, which provides seamless mobility of the hosts, tenant isolation, large name space for L2 segments, and traffic entropy across all the ECMP paths.

**Spine Switches:** In the VXLAN fabric, spine switches provide connectivity between all the leaf switches by using high speed links. Spines are not used to connect end-hosts.

**Leaf Switches:** Leaf switches function as VTEP and are responsible for the encapsulation and decapsulation of the VXLAN header. End-hosts are terminated on the leaf switches.

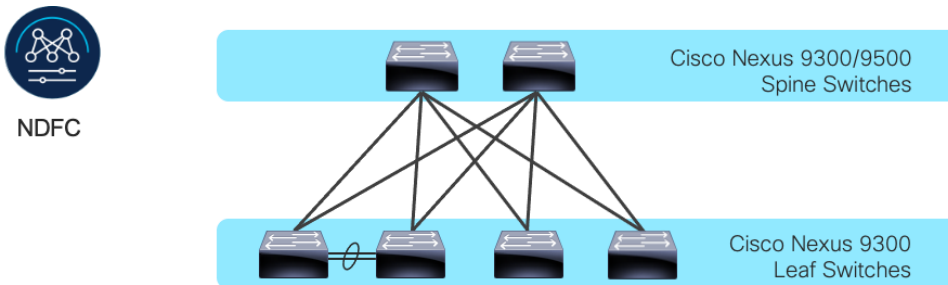

**Figure 4.**  
Cisco NX-OS based Fabric Components

## Solution Design

Prior to implementing the solution, it is important to understand the logical architecture of the Microsoft Azure Local and how it maps to the underlying physical architecture. This section describes the logical and physical connectivity of the Microsoft Azure Local, and the Nexus 9000 Series Switch based network with either the Cisco ACI or Cisco NX-OS mode.

### Physical Architecture

Each Cisco UCS C240 M6/M7 server is connected to a pair of Cisco Nexus 9000 Top-of-Rack (ToR) switches using dual 100-Gb connections. In this example, the Cisco Nexus 9000 Series Switch based data center network carries all the Azure Local network traffic (management for host operating system, cluster communication, compute, and storage traffic). You can also use different networks.

Physical server management, such as Cisco Integrated Management Controller (CIMC) on Cisco UCS C series, is facilitated through an Out-of-band (OOB) management network that connects the server's dedicated management port to an OOB management switch with 1GbE links.

The following diagram illustrates a high-level physical architecture design:

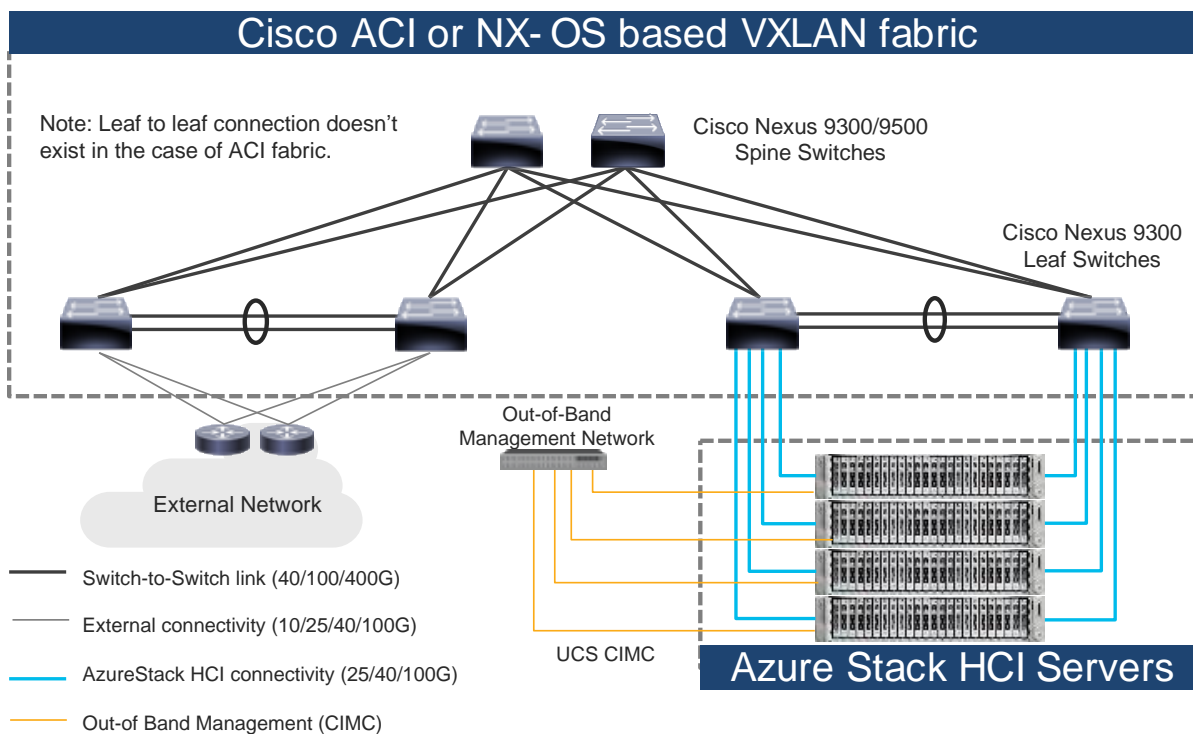

**Figure 5.**  
Physical Architecture (Cisco ACI or NX-OS mode)

In the case of Cisco NX-OS mode, the use of spine-leaf topology is not mandatory though it's a common design option whereas the Cisco ACI mode requires spine-leaf topology. Although downstream vPC is not used to connect the Microsoft Azure Local server to a pair of ToR switches, the use of vPC peer-link is recommended.

**Note:** As the only difference between ACI based fabric and NX-OS based fabric is a vPC peer-link, this document uses the topology illustration with a vPC peer-link. This vPC peer-link doesn't exist in the ACI fabric.

Physical connectivity considerations include the following:

- Microsoft recommends a 10+ Gigabit Ethernet network with remote-direct memory access (RDMA). For UCS C240 M6/M7 based Azure Local, the NVIDIA ConnectX-6X dual Port 100 Gigabit Ethernet NIC card is required. (Cisco VIC is currently not an option).  
Microsoft requires that all server nodes be configured the same.  
Up to 16 Azure Local servers per cluster.
- The Microsoft Azure Local server interfaces are connected to a pair of ToR switches with individual links, not Virtual Port Channel (vPC).
- The pair of ToR switches don't have to be dedicated to Azure Local connectivity.
- The ToR switches are configured for a MTU size of 9216. The MTU size for the packets sent on the network are controlled by the endpoints.

## Logical Architecture

The network infrastructure for Azure Local consists of several logical networks:

- Tenant (Compute) Network: The tenant network is a VLAN trunk that carries one or more VLANs that provide access to the tenant virtual machines. Each VLAN is provisioned in the ToR switch and the SET switch that is running on the physical server. Each tenant VLAN is expected have an IP subnet assigned to it.
- Management Network (native VLAN is preferred but tagged VLAN is also supported): The management network is a VLAN that carries network traffic to the parent partition. This management network is used to access the host operating system. The connectivity to the management network is provided by the management (Mgmt) vNIC in the parent partition. Fault tolerance for the management vNIC is provided by the SET switch. A bandwidth limit can be assigned to the management, as necessary.
- Storage Network: The storage network carries RoCEv2 network traffic that is used for Storage Spaces Direct, storage replication, and Live Migration network traffic. The storage network has a Storage A and a Storage B segment, each with its own IP subnet. This design keeps the east-west RDMA isolated to the ToR switches.  
In this document, the storage network is also used as a preferred path for cluster communication. (If both Storage A and Storage B segments are not available, the management network is used for cluster communication).

The following diagrams illustrate the tenant and management network (Figure 6) and storage network (Figure 7). For tenant and management network, ToRs provide the gateway functionality.

The default gateway of servers running on Azure Local are the anycast gateways provided by the ToRs.

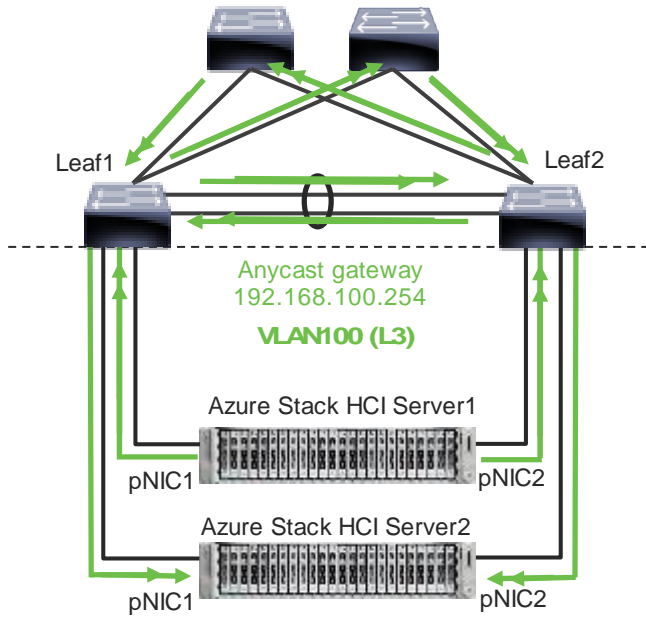

Note: vPC peer-link doesn't exist for ACI fabric.

**Figure 6.**  
Azure Local Logical Architecture (tenant and management network)

Unlike tenant and management networks, storage networks require separate VLANs to connect a pair of ToRs. For example, VLAN 10 is used to connect Leaf1 (Storage A segment) and VLAN 20 is used to connect Leaf2 (Storage B segment).

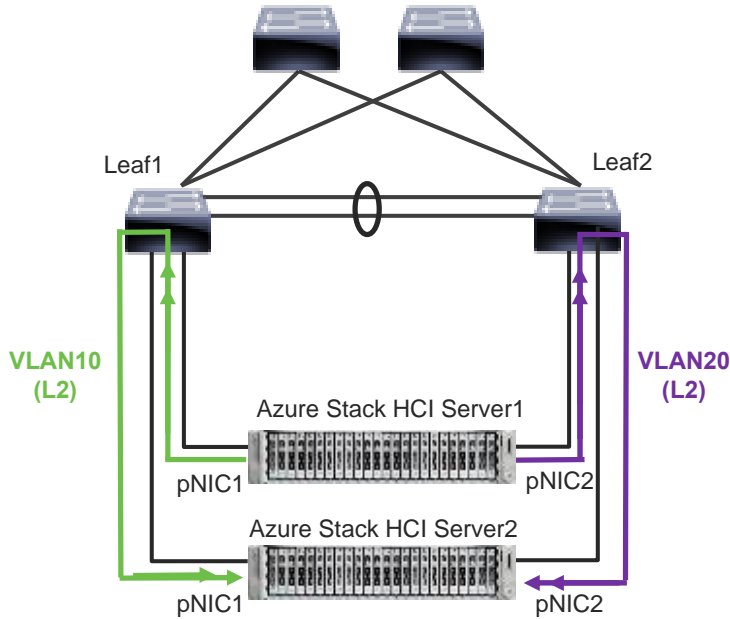

Note: vPC peer-link doesn't exist for ACI fabric.

**Figure 7.**  
Azure Local Logical Architecture (storage network)

Storage network design considerations include the following:

- The storage network is used for Layer 2 communication only, where gateways on the ToR switches are not required.
- The storage network carries RoCEv2 traffic that is used for Storage Spaces Direct, storage replication, and Live Migration network traffic. Also used as a preferred path for cluster communication in this document.
- RoCE requires Data Center Bridging (DCB) to make the network lossless (DCB is optional for iWARP). If DCB is used, PFC and ETS configuration needs to be implemented in the network.
- As the storage network is also used as a preferred path for cluster communication in this document a different QoS configuration is required for storage traffic and cluster communication traffic. For example, Cos 4 is for storage traffic and Cos 7 is for cluster communication traffic.

The following table shows the [QoS recommendations provided by Microsoft](#):

**Table 1. Azure Local network QoS recommendation**

	Cluster Communication Traffic	Storage traffic	Default (Tenant and Management Networks)
Purpose	Bandwidth reservation for cluster heatbeats	Bandwidth reservation for lossless RDMA communication used for Storage Spaces Direct	For all other traffic such as tenant networks.
Flow Control (PFC enabled)	No	Yes	No
Traffic Class	7	3 or 4	0 (default)
Bandwidth reservation	1% for 25GbE or higher RDMA networks 2% for 10GbE or lower RDMA networks	50%	Default (no host configuration required)

**Note:** Although the storage network is also used as a preferred path for cluster communication in this document, cluster communication could take any available network called as a preferred path. This path is chosen based on the metric role that is defined in the cluster network configured through Microsoft Network ATC. (Microsoft Network ATC provides an intent-based approach (management, compute, or storage) to host network deployment on the Azure Local servers. See [Microsoft Network ATC document](#) for details.) In this example, three cluster networks exist: Storage A, Storage B, and Management.

```
PS C:\Users\Administrator.MIHIGUCH> Get-ClusterNetwork

Name                               State Metric      Role
----                               -
mgmt_compute_storage(Management)  Up    68800 ClusterAndClient
mgmt_compute_storage(Storage_VLAN1601) Up    19200 Cluster
mgmt_compute_storage(Storage_VLAN1602) Up    19201 Cluster
```

**Figure 8.**

Azure Local Cluster Networks. The inside of an Azure Local server has the following network components:

- SET Switch: This is a virtual switch with embedded teaming capabilities. The SET switch provides teaming capabilities for network traffic that does not use the SMB-Multichannel. SMB Direct (RDMA)

traffic uses SMB-Multichannel\* to leverage available network connections for bandwidth and redundancy instead of the teaming feature in the SET switch.

- Guest Partition: The tenant virtual machines run in the guest partition on the Hyper-V host. Each virtual machine runs in isolation from others and does not have direct access to the physical hardware in the host. Network connectivity is provided to the tenant virtual machine by connecting synthetic NIC in the virtual machine to the SET switch on the host.
- Parent Partition: The parent partition is the host operating system that runs the virtualization management stack and has access to the physical server hardware. The parent partition has one management vNIC and two storage vNICs as shown in the example below. An optional dedicated vNIC for backup operations can be added, if needed.

\* SMB Multichannel is part of the Server Message Block (SMB) 3.0 protocol, which increases the network performance and the availability of file servers. SMB Multichannel enables file servers to use multiple network connections simultaneously.

The following diagrams illustrate a logical network diagram within an Azure Local server. In this example, Storage A and Storage B are for the parent partition only, whereas management network is available for both parent partition and VMs in the guest partition. By default, the “Allow management operating system to share this network adapter” option is enabled on vNIC on the SET switch. In this example, it’s enabled on the management vNIC (Yellow) whereas it’s disabled on the storage vNICs (Green and Purple).

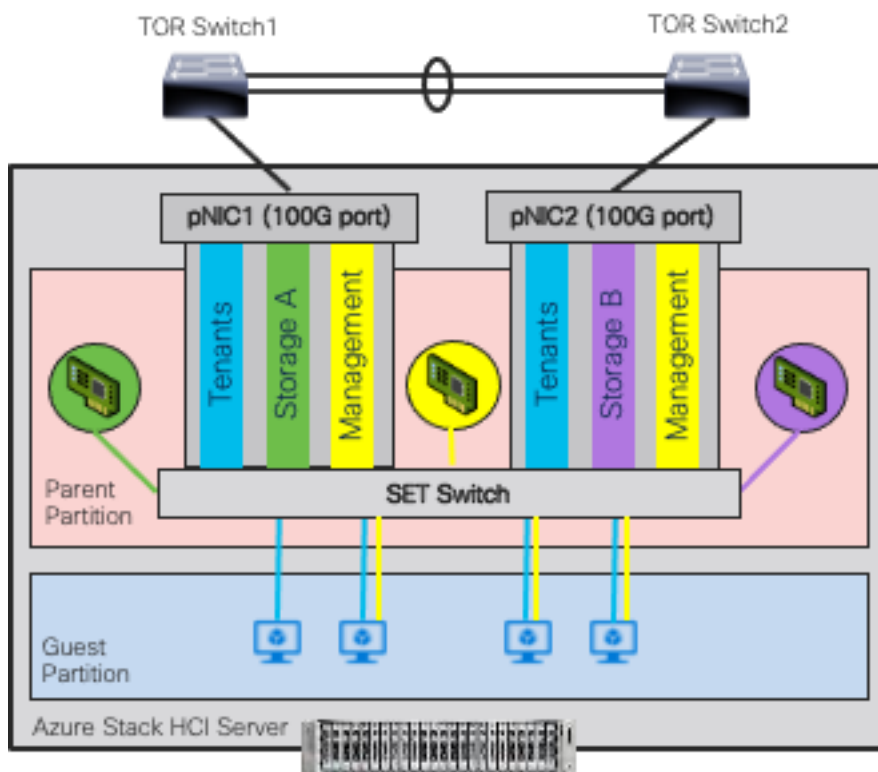

Note: vPC peer-link doesn't exist for ACI fabric.

**Figure 9.** Azure Local Logical Architecture (SET Switch, Guest, and Parent Partitions)

MAC addresses for the VM virtual NICs are dynamically assigned, and the SET switch selects one of the available uplinks (physical NICs on the server) based on the source MAC address. This behavior provides load balancing and fault tolerance. The following diagram illustrates an example of how traffic from virtual machine A

with virtual NIC MAC-A uses physical NIC1 as the uplink whereas traffic from virtual machine B with virtual NIC MAC-B uses physical NIC2 as the uplink. If the path using physical NIC1 is not available, all traffic goes through the other path.

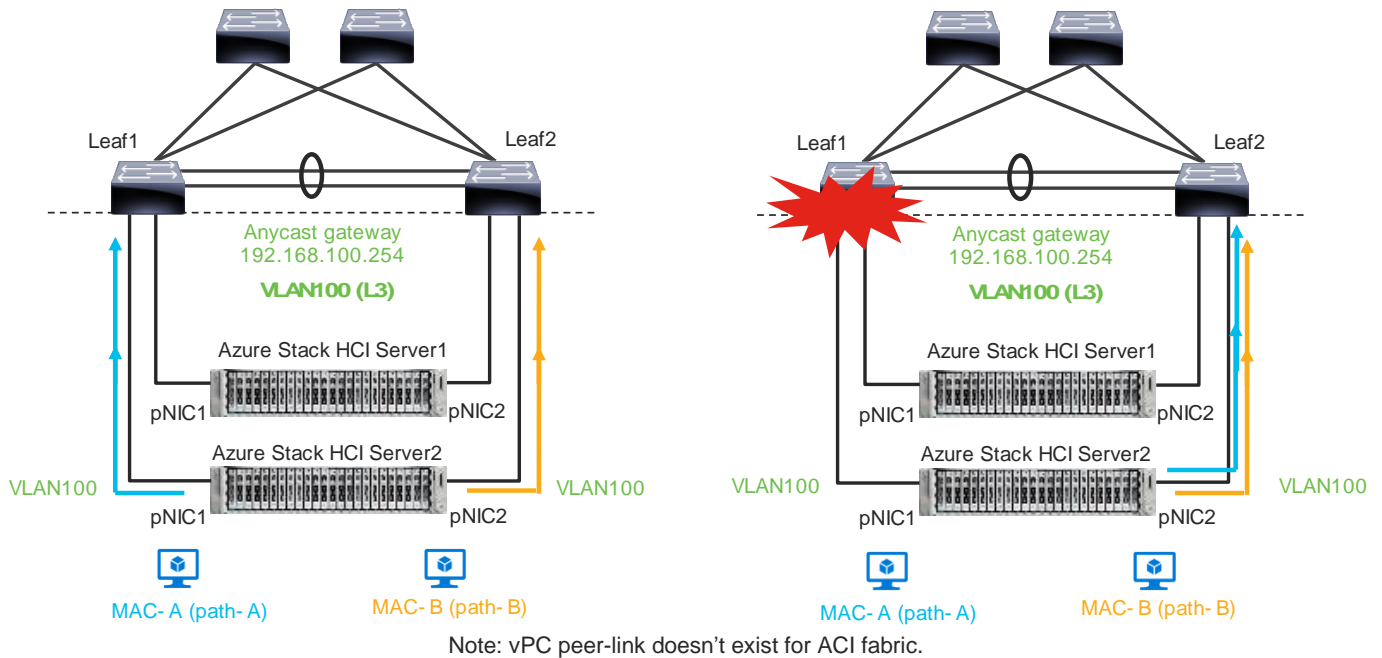

**Figure 10.**  
Load balancing behavior based on MAC address.

A consequence of this behavior is that some of the east-west network traffic that is not storage traffic transverse the spine (in the case of ACI) or vPC peer-link (in the case of NX-OS).

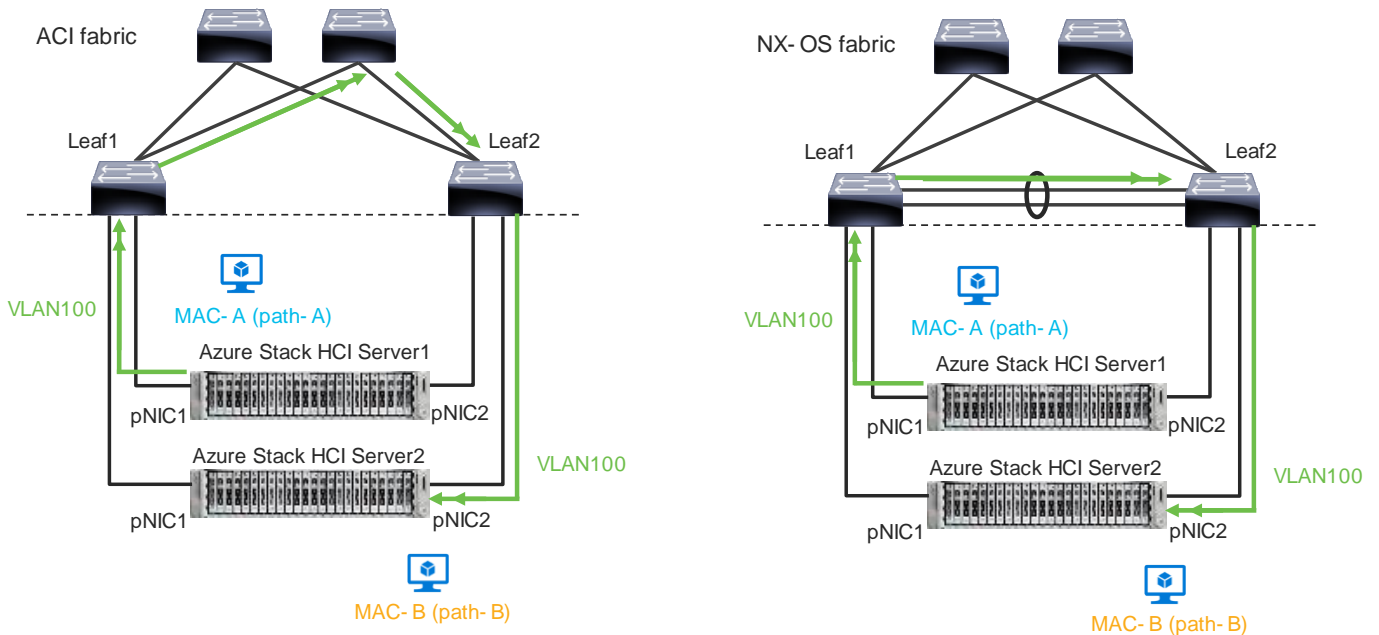

**Figure 11.**  
Traffic flow example



The network needs to allow the required traffic. Firewall requirements for Azure Local can be found at <https://learn.microsoft.com/en-us/azure/azure-local/concepts/firewall-requirements>

## Cisco Nexus 9000 Series Switch based Fabric and Benefit

The table below lists the main features and benefits of the Nexus 9000 Series Switches based data center fabric.

**Table 2. Features and Benefits**

Features	Benefit	ACI/NX-OS
Single point of Management	The use of the controller (APIC or NDFC) provides single point of configuration management and policy definition, which simplifies the operational aspects of the fabric.	ACI: APIC NX-OS: NDFC
Anycast Gateway	The fabric operates as an anycast gateway for the VMs on Azure Local servers and other physical/virtual servers. Layer 3 gateway functionality is provided by ToR switches instead of core or aggregation switches.	Both
VXLAN	The use of the VXLAN provides seamless Layer 2 and Layer 3 connectivity between servers, independently from the physical Leaf location. It also provides multi-tenancy.	Both
Multi-Pod/Multi-Site	Multi-Pod/Multi-Site fabric provides seamless Layer 2 and Layer 3 connectivity between endpoints, independently from the physical locations across data centers.	ACI: Multi-Pod, Multi-Site and Remote Leaf NX-OS: Multi-Site
Service Chaining	The use of Service Chaining capability provides flexible traffic redirection to L4-L7 service devices such as firewalls and load balancers.	ACI: Service Graph PBR NX-OS: ePBR

**Figure 12**  
Cisco ACI connectivity options and policy domain evolution



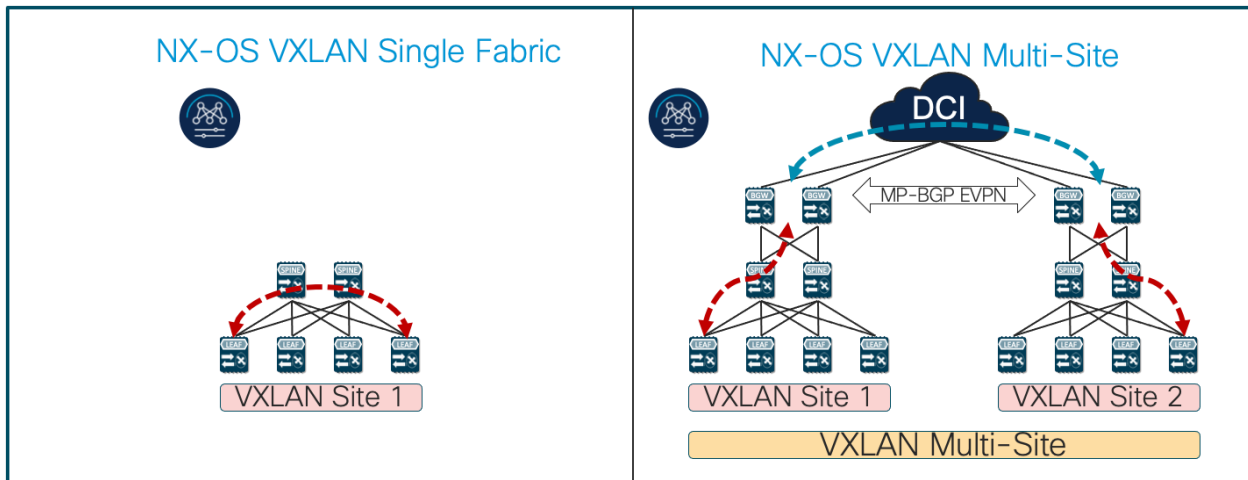

- Single Fabric with End-to-End Encapsulation
- Single Overlay domain
- Multiple Fabrics with Integrated DCI
- Integrated DCI – Scaling within and between Fabrics
- Multiple Overlay domains
- End-to-End automation support by NDFC

**Figure 13.**  
Cisco Nexus 9000 Series Switch based Fabric and Benefit

### Cisco ACI Design for Azure Local Connectivity

This section explains how Azure Local can connect to Cisco ACI by using the EPG and bridge domains.

This design assumes that the customer already has the Cisco ACI fabric in place with spine switches and APICs deployed and connected through a pair of leaf switches.

#### Cisco ACI for Azure Local Connectivity

The figure below shows the basic traffic flow of Azure Local traffic through the Cisco ACI fabric. In this design, the Cisco ACI fabric has two pairs of leaf nodes and two spine nodes, which are controlled by an APIC cluster. A pair of border leaf switches have the L3Out configured. This provides connection to a pair of external routers and thus to the Internet and Enterprise networks. Another pair of leaf nodes are connected to the Azure Local servers and other servers.

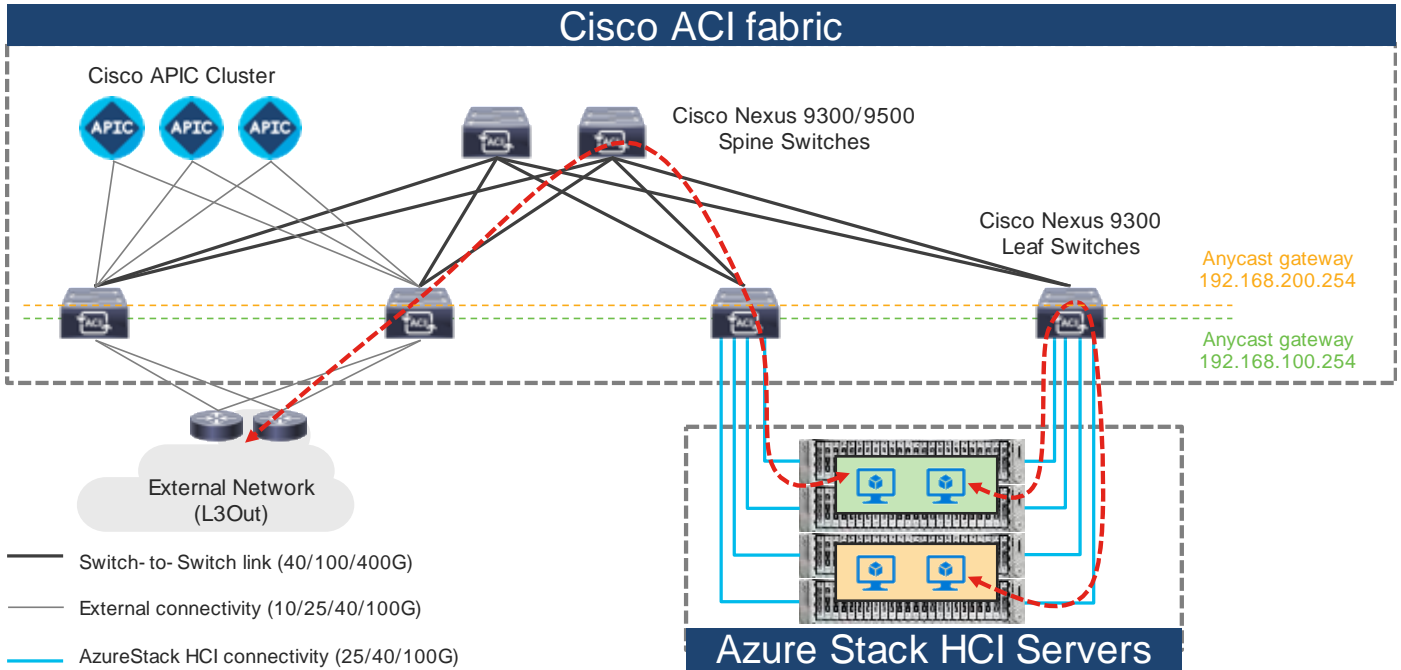

**Figure 14.**  
Azure Local Traffic flow via Cisco ACI Fabric

In this design, each leaf switch is connected to the Azure Local servers by using the 100GbE links. The two links between the ACI leaf switches and each Azure Local server are individual connections instead of a port-channel or vPC.

The figure below illustrates an ACI interface configuration example along with the domain and the VLAN pool configuration. Although it's possible to use different interfaces on a pair of ToR switches, this document uses the same interfaces: **node-101 (ethernet1/11 and 1/12)** and **node-102 (ethernet1/11 and 1/12)**. The figure below illustrates an ACI interface configuration example.

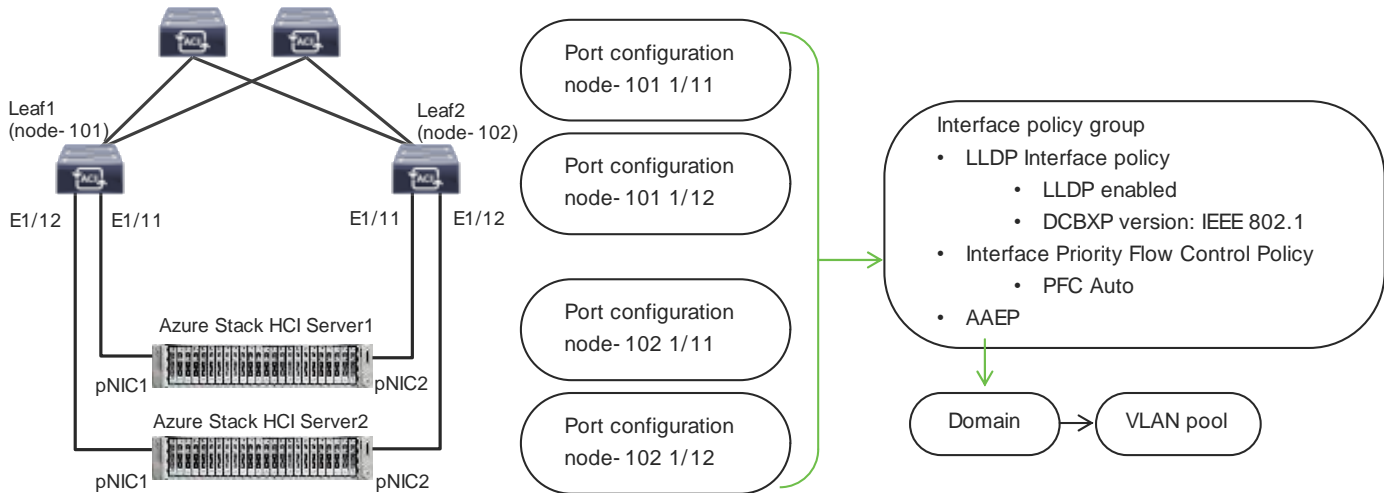
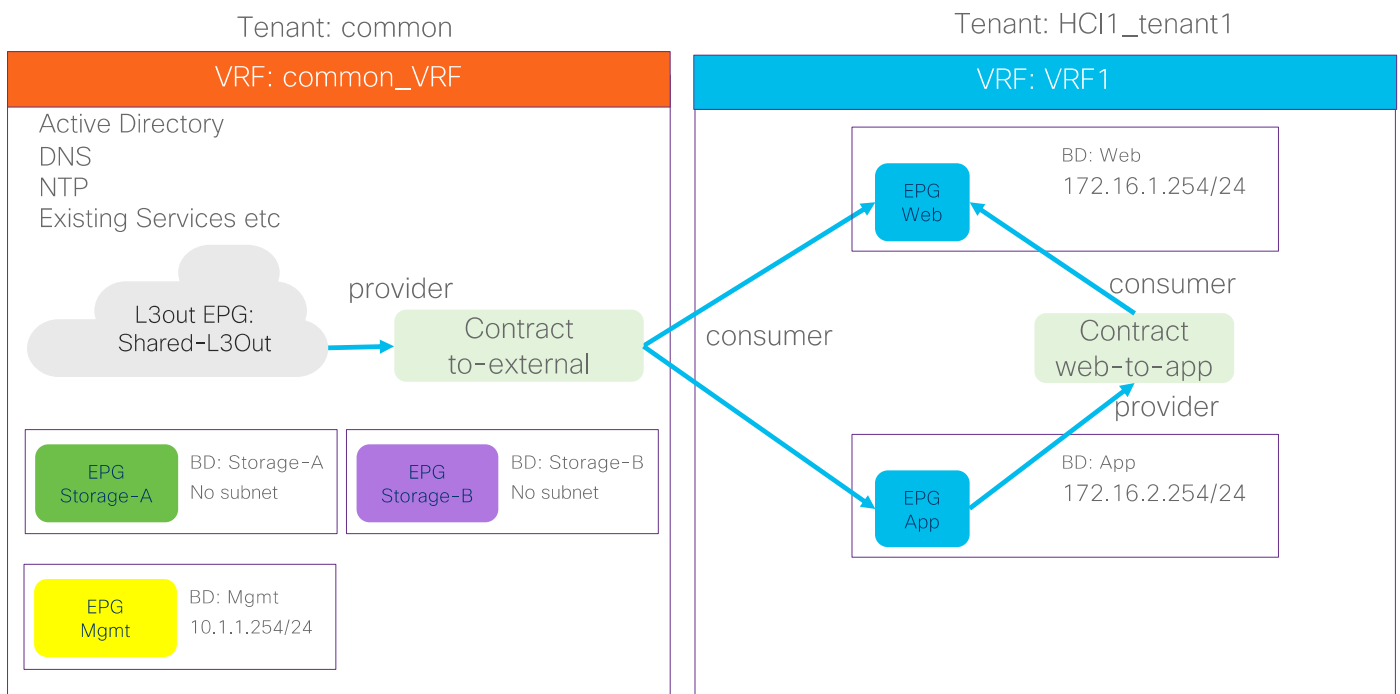

**Figure 15.**  
ACI leaf interface configuration for Azure Local servers

## Azure Local ACI Tenant Model Overview

The figure 16 illustrates an example of a high-level relationship between various ACI tenant elements as deployed in the design by highlighting the Azure Local tenant. In this example, Azure Local tenant (HCI\_tenant1) contains Virtual Routing and Forwarding (VRF), Bridge domains (BD), and end point groups (EPGs) for tenant networks, and the common tenant contains an external connectivity (L3Out) and EPGs for storage and management networks.

For Azure Local tenant networks to be able to communicate with other data center networks and access external networks, a contract must exist between the EPG in tenant **HCI1\_tenant1** and the other EPG in the same tenant and the external EPG (L3Out EPG) in the common tenant. For the EPGs in storage network A and B, the storage traffic is within its segment (BD), then there is no need to configure a contract with another EPG.



**Figure 16.**  
ACI Tenant Overview for Azure Local

In addition to the generic ACI configuration, the following configurations are required for the Azure Local network:

- Enable the required LLDP TLVs on the interfaces that are connected to the Azure Local servers
- QoS configuration for storage and cluster communication

For more information about configuring Cisco ACI and NDFC Fabric, see Solution Deployment.

## Cisco NX-OS based Fabric Design for Azure Local Connectivity

This section explains how Azure Local can connect to Cisco Nexus 9000 Series Switches in the NX-OS mode.

You can use the Cisco Nexus 9000 NX-OS based VXLAN or the traditional classical LAN fabrics to connect to the Azure Local environments. VXLAN leverages ECMP based multipathing over L3 links between the spine switches and Leaf switches and the traditional classic LAN fabric uses the L2 links (between Access and Aggregation devices) running STP. VXLAN is gaining more popularity and adoption for building data center fabrics because of its benefits over the traditional classical LAN.

VXLAN uses CLOS architecture where Leafs (also known as VTEP) are used to connect the end-host and performs origination and termination of VXLAN tunnels while Spine switches provide layer-3 connectivity between the Leaf switches.

Both these fabrics can be built and managed by Cisco NDFC. This enables faster and error-free deployment unlike the CLI-based approach that was used previously. Cisco NDFC supports various fabric templates to cater to any kind of data center fabric deployment. For the interest of Azure Local, Data Center VLXAN EVPN and Enhanced Classic LAN fabric templates are the ones which should be used. This document describes the steps and workflows to connect Azure Local to the VXLAN fabric.

### Cisco NX-OS based Fabric for Azure Local Connectivity

The figure below illustrates the basic traffic flow of Azure Local traffic through the NX-OS based VXLAN fabric.

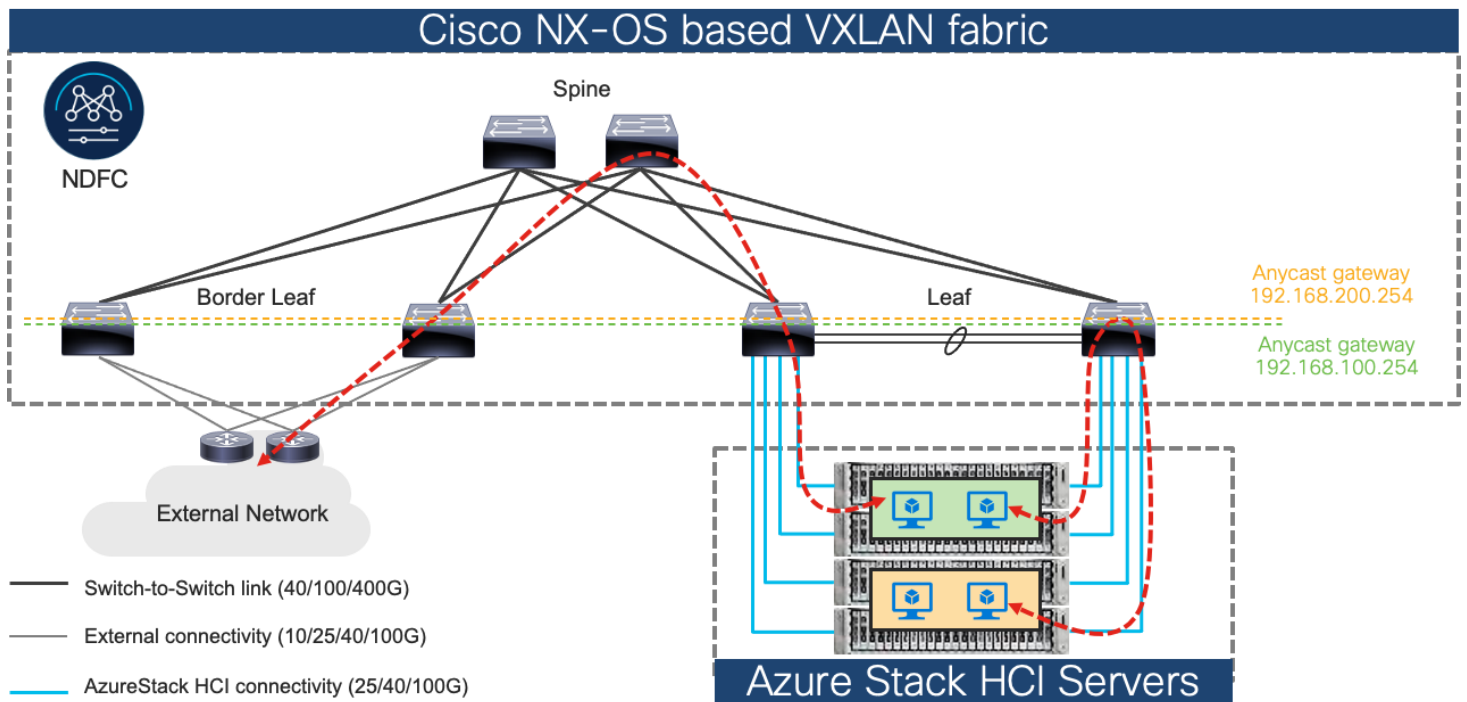

**Figure 17.**  
Azure Local Traffic flow through Cisco NX-OS based VXLAN fabric

In this design, a pair of leaf switches in vPC are connected to the Azure Local servers by using the 100 Gigabit Ethernet links. The two links between the leaf switches and each Azure Local server are individual connections instead of a port-channel or vPC.

## Solution Deployment

This section provides a detailed procedure to configure the Cisco ACI and Cisco NDFC fabric to use in the environment. It also explains how to add new components to an existing Cisco ACI or the Cisco NDFC fabric.

**Note:** After the Cisco ACI or Cisco NDFC configuration is completed as per the procedure in this document, Azure Local cluster can be installed. Before you register the Azure Local, you can use [the connectivity validator](#) (`Invoke-AzStackHciConnectivityValidation`) on the Azure Local nodes or any other computer in the same network where you'll deploy the Azure Local cluster. This validator checks the network connectivity that is required to register the Azure Local cluster to Azure.

**Note:** This document does not cover the Cisco ACI or Cisco NDFC fabric deployment and the automated installation of Azure Local.

**Table 3** lists the hardware and software versions that are used in this solution.

**Table 3. Hardware and Software Versions**

Layer	Device	Software version	Comments
<b>Cisco ACI</b>	Cisco APIC	6.0 (3e)	ACI Controller
	Cisco Nexus Switches in ACI Mode	16.0(3e)	ACI Spine and Leaf switches
<b>Cisco NX-OS</b>	Cisco NDFC	12.1.3b	NDFC
	Cisco Nexus Switches in NX-OS mode	10.2(3F)	ToR switches
<b>Cisco Azure Local</b>		2022H2	Azure Local release (Includes individual releases of software for all the devices that are part of Azure Local)

### Cisco ACI Configuration for Azure Local

This section explains how to configure Cisco ACI for Azure Local servers with the assumption that the ACI fabric and APICs already exists in the customer's environment. This document does not cover the configuration required to bring the initial ACI fabric online.

The following are the configuration steps to configure Cisco ACI for Azure Local Servers:

- Configuring leaf interfaces connected to Azure Local servers
- Configure QoS
- Configure EPGs

### Configuring Leaf Interfaces Connected to Azure Local Servers

This section contains the following steps:

- Create VLAN Pool for Azure Local Physical Domain
- Configure Physical Domain for Azure Local
- Create Attachable Access Entity Profile for Azure Local Physical Domain
- Create LLDP policy to enable the required TLVs for Azure Local
- Create Interface Priority Flow Control Policy to enable the required TLVs for Azure Local
- Create Interface Policy Group for Interfaces connected to Azure Local servers
- Associate the Interface Policy Group to the leaf interfaces connected to Azure Local servers

Figure 18 and Table 4, summarize the topology, interface, and physical domain configuration parameters used in this section. The connection uses four 100 GbE interfaces between ACI Leaf switches and Azure Local servers.

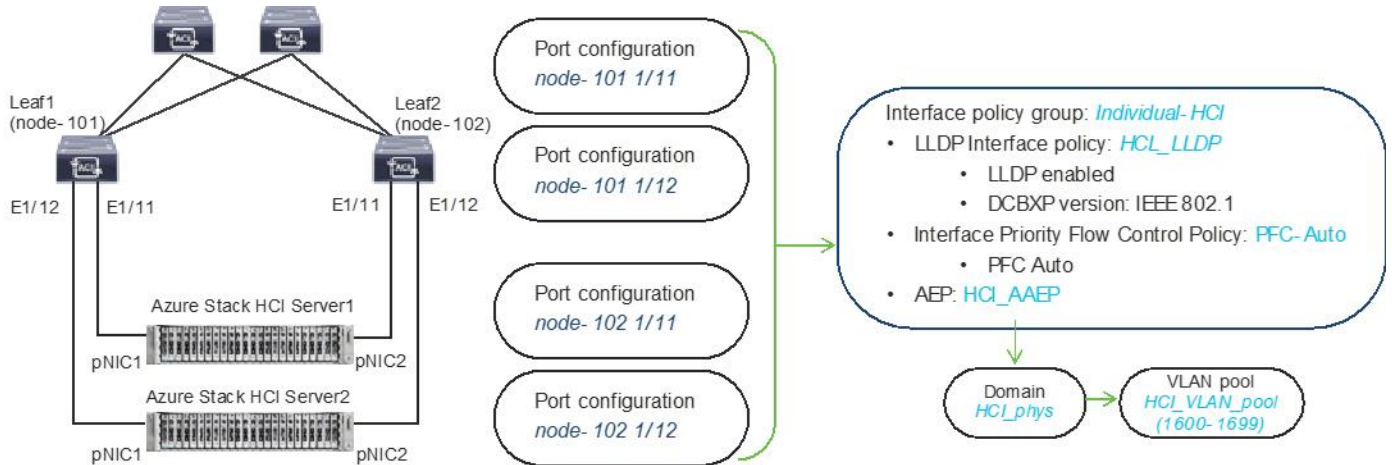
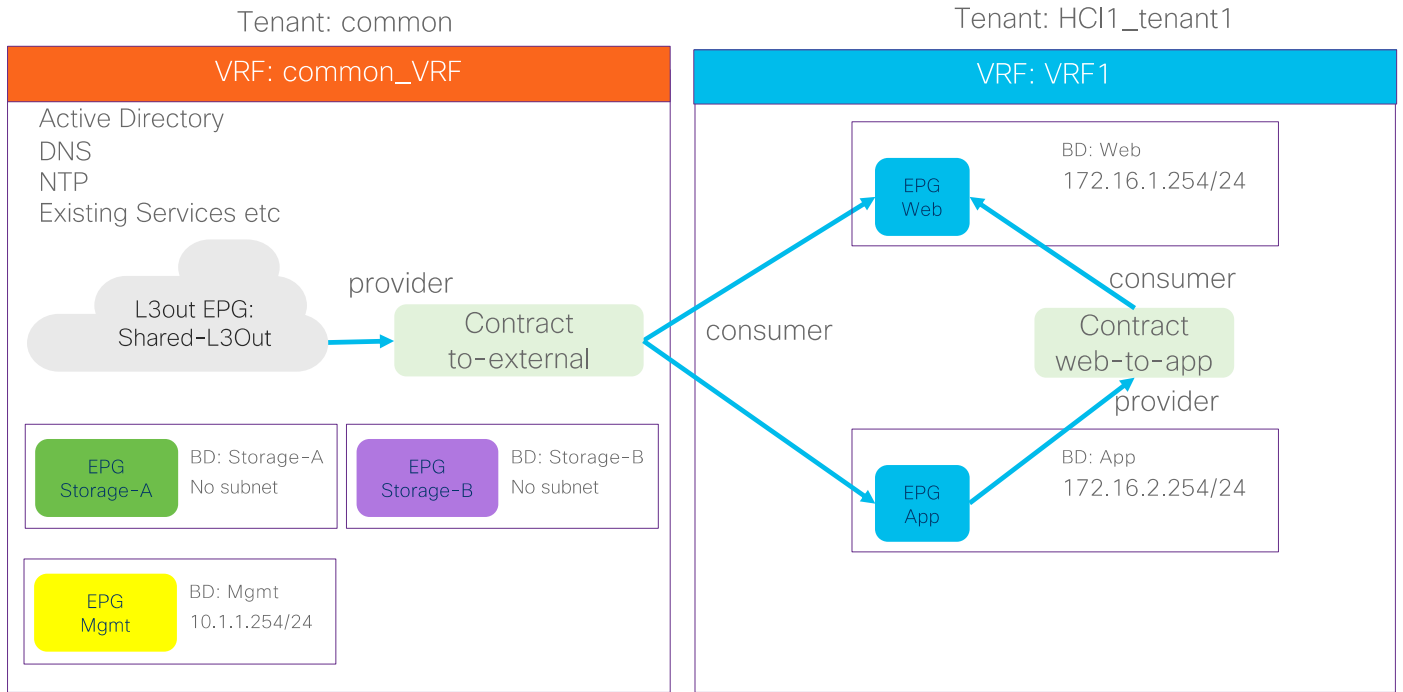

**Figure 18.** Interface and physical domain configuration for Azure Local Servers

**Table 4. Interface and physical domain configuration for Azure Local Servers**

Interface	Interface Policy Group	LLDP Interface Policy	Interface PFC Policy	AAEP Name	Domain Name	Domain type	VLAN Pool
Leaf1 and Leaf2 Ethernet 1/11-12	Individual-HCI	HCI_LLDP (DCBXP: IEEE 802.1)	PFC-Auto	HCI_AAEP	HCI_phys	Physical	HCI_VLAN_pool (VLAN 1600-1699)

Tables 5 and 6 summarize the common and the user tenant configuration parameters that are used in this section. The ACI Leaf switches serve as the gateway to the Azure Local networks except storage networks that are L2 only. Although contract names are listed for your reference, the Shared L3Out configuration in common tenant and contract configuration steps are not covered in this document.



**Figure 19.**  
Tenant configuration example

**Table 5. Azure Local common tenant configuration example**

Property	Name
Tenant	common
Tenant VRF	common_VRF
Bridge domains	Storage-A in common_VRF (No subnet) Storage-B in common_VRF (No subnet) Mgmt in common_VRF (10.1.1.254/24)
Leaf nodes and interfaces	Node 101 & 102 ethernet1/11 and 1/12
EPGs	EPG Mgmt in BD Mgmt (VLAN 1600) EPG Storage-A in BD Storage-A (VLAN 1601) EPG Storage-B in BD Storage-B (VLAN 1602)
External EPG (L3 Out)	Shared_L3Out in common tenant
Contract	Allow-Shared-L3Out provided by common tenant

**Table 6. Azure Local tenant configuration example**

Property	Name
Tenant	HCI_tenant1
Tenant VRF	VRF1

Property	Name
Bridge domain	BD1 (192.168.1.254/24) in VRF1
Leaf nodes and interfaces	Node 101 & 102 ethernet1/11 and 1/12
EPGs	Web EPG in BD1 (VLAN 1611) App EPG in BD1 (VLAN 1612)
Contract	Allow-Shared-L3Out provided by common tenant Web-App contract defined in the tenant

### Create VLAN Pool for Azure Local Physical Domain

In this section, you will create a VLAN pool to enable connectivity to the Azure Local.

To configure a VLAN pool to connect the Azure Local servers to the ACI Leaf switches, follow these steps:

1. From the APIC top navigation menu, select **Fabric > Access Policies**.
2. From the left navigation pane, expand and select **Pools > VLAN**.
3. Right-click and select **Create VLAN Pool**.
4. In the **Create Pool** pop-up window, specify a Name (For example, **HCI\_VLAN\_pool**) and for Allocation Mode, select **Static Allocation**.
5. For **Encap Blocks**, use the **[+]** button on the right to add VLANs to the VLAN Pool. In the **Create Ranges** pop-up window, configure the VLANs that need to be configured from the Leaf switches to the Azure Local servers. Leave the remaining parameters as is.



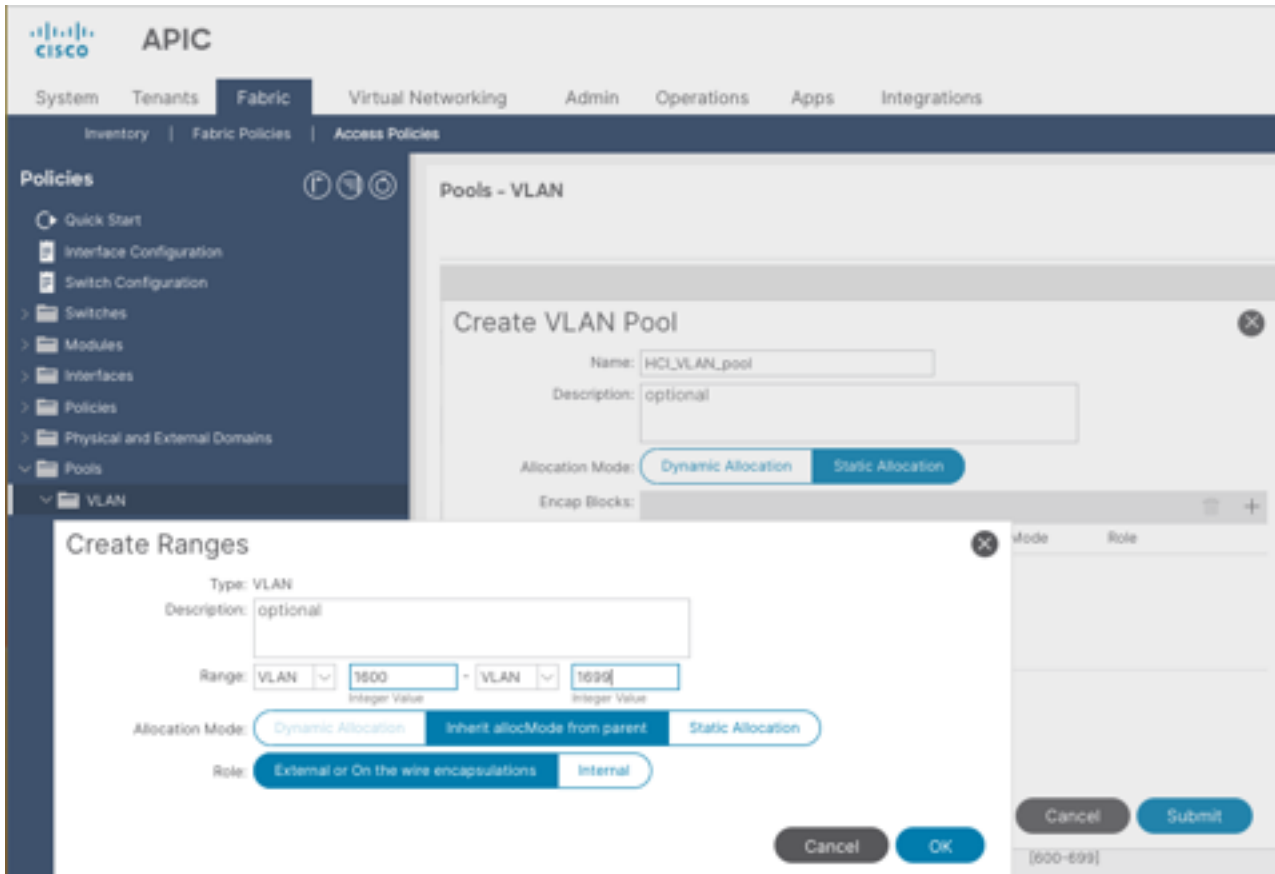

6. Click **OK**.
7. Click **Submit**.

### Configure Physical Domain for Azure Local

To create a physical domain type, connect to Azure Local servers, follow these steps:

1. From the APIC top navigation menu, select **Fabric > Access Policies**.
2. From the top navigation menu, select **Fabric > Access Policies**.
3. From the left navigation pane, expand and select **Physical and External Domains > Physical Domains**.
4. Right-click **Physical Domains** and select **Create Physical Domain**.
5. In the **Create Physical Domain** pop-up window, specify a Name for the domain (For example, **HCI\_phys**). For the VLAN Pool, select the previously created VLAN Pool (For example, **HCI\_VLAN\_pool**) from the drop-down list.

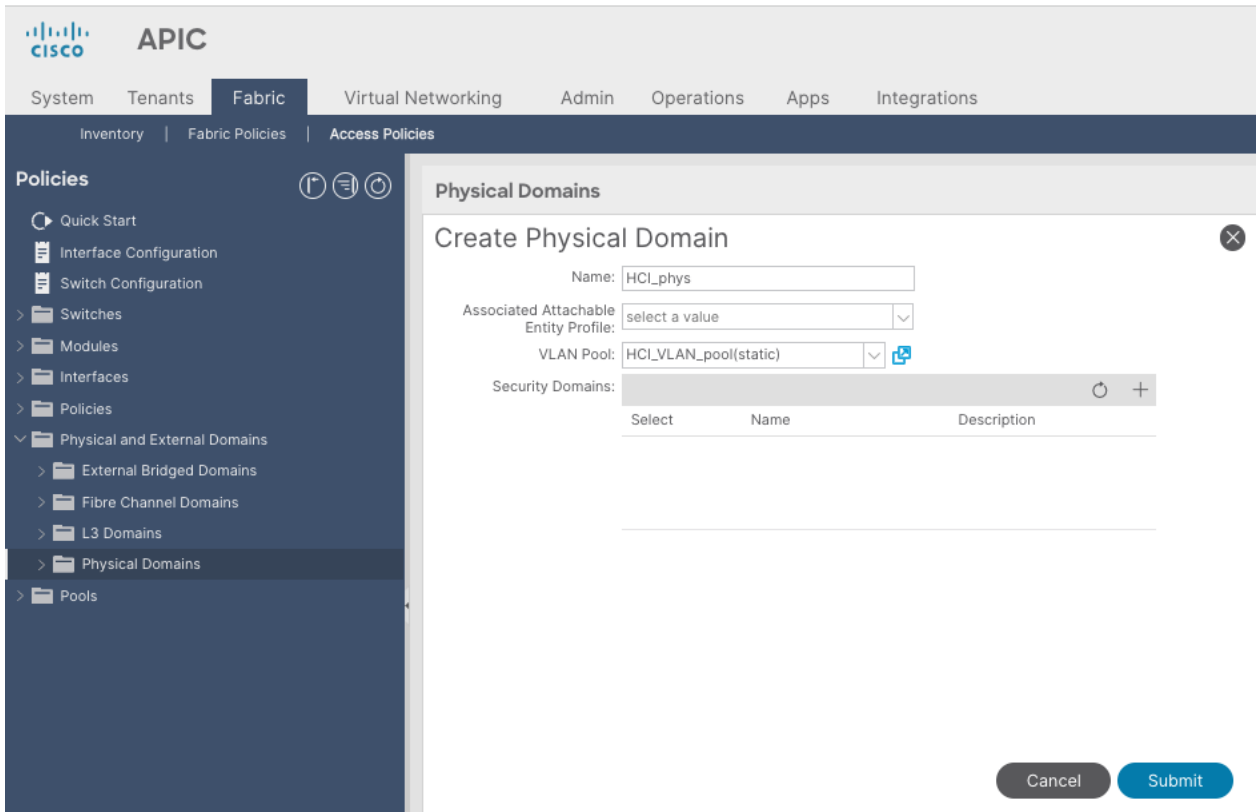

6. Click **Submit**.

## Create Attachable Access Entity Profile for Azure Local Physical Domain

To create an Attachable Access Entity Profile (AAEP), follow these steps:

1. From the APIC top navigation menu, select **Fabric > Access Policies**.
2. From the left navigation pane, expand and select **Policies > Global > Attachable Access Entity Profiles**.
3. Right-click and select **Create Attachable Access Entity Profile**.
4. In the **Create Attachable Access Entity Profile** pop-up window, specify a Name (For example, **HCI\_AAEP**) and **uncheck "Enable Infrastructure VLAN" and "Association to Interfaces"**.
5. For the **Domains**, click the **[+]** on the right-side of the window and select the previously created domain from the drop-down list below **Domain Profile**.
6. Click **Update**.
7. You should now see the selected domain and the associated VLAN Pool as shown below.
8. Click **Next**. This profile is not associated with any interfaces at this time because "Association to Interfaces" is unchecked at step 4 above. They can be associated once the interfaces are configured in an upcoming section.

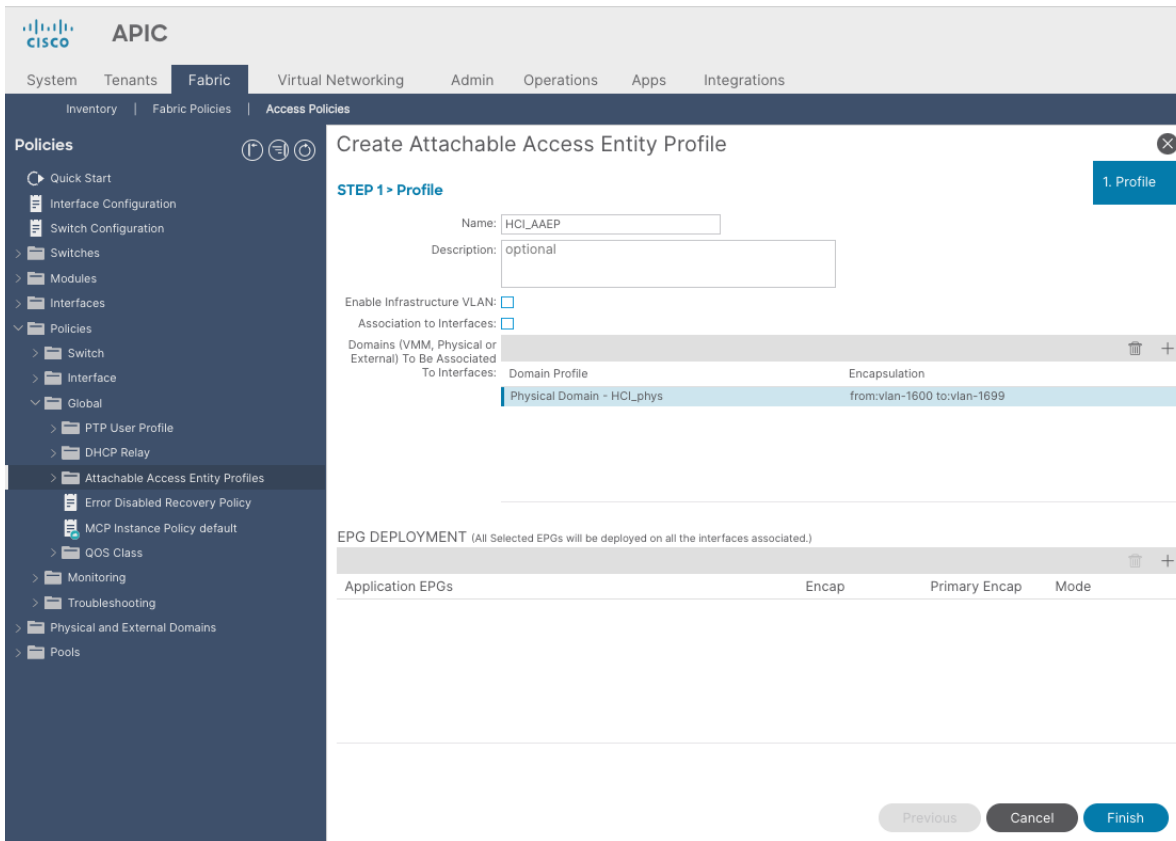

9. Click **Finish**.

## Create LLDP policy to Enable the Required TLVs for Azure Local

To create an LLDP policy to enable the required TLVs for Azure Local, follow these steps:

1. From the APIC top navigation menu, select **Fabric > Fabric Policies**.
2. From the left navigation pane, expand and select **Policies > Global > LLDP policy by default**.
3. Check the following optional TLVs:
  - i. **DCBX** (for storage network)
  - ii. **Port Link Aggregation**
  - iii. **Port Maximum Frame Size**
  - iv. **Port VLAN Name**

**Note:** Port VLAN, that is also required for Azure Local, is always enabled regardless LLDP policy configuration.

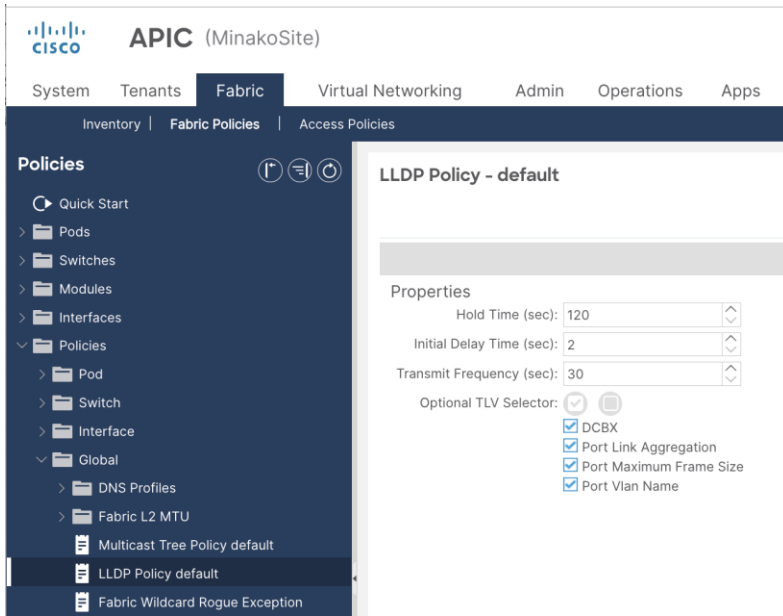

4. Click **Submit**.

## Create LLDP Interface Policy

To create an LLDP policy to enable the required TLVs for Azure Local, follow these steps:

1. From the APIC top navigation menu, select **Fabric > Access Policies**.
2. From the left navigation pane, expand and select **Policies > Interfaces > LLDP Interfaces**.
3. Right-click and select **Create LLDP Interface Policy**.
4. In the **Create LLDP Interface Policy** pop-up window, specify a Name (For example, **HCI\_LLDP**).
5. Select **Enable** for Transmit State
6. Select **IEEE 802.1** for DCBXP Version.

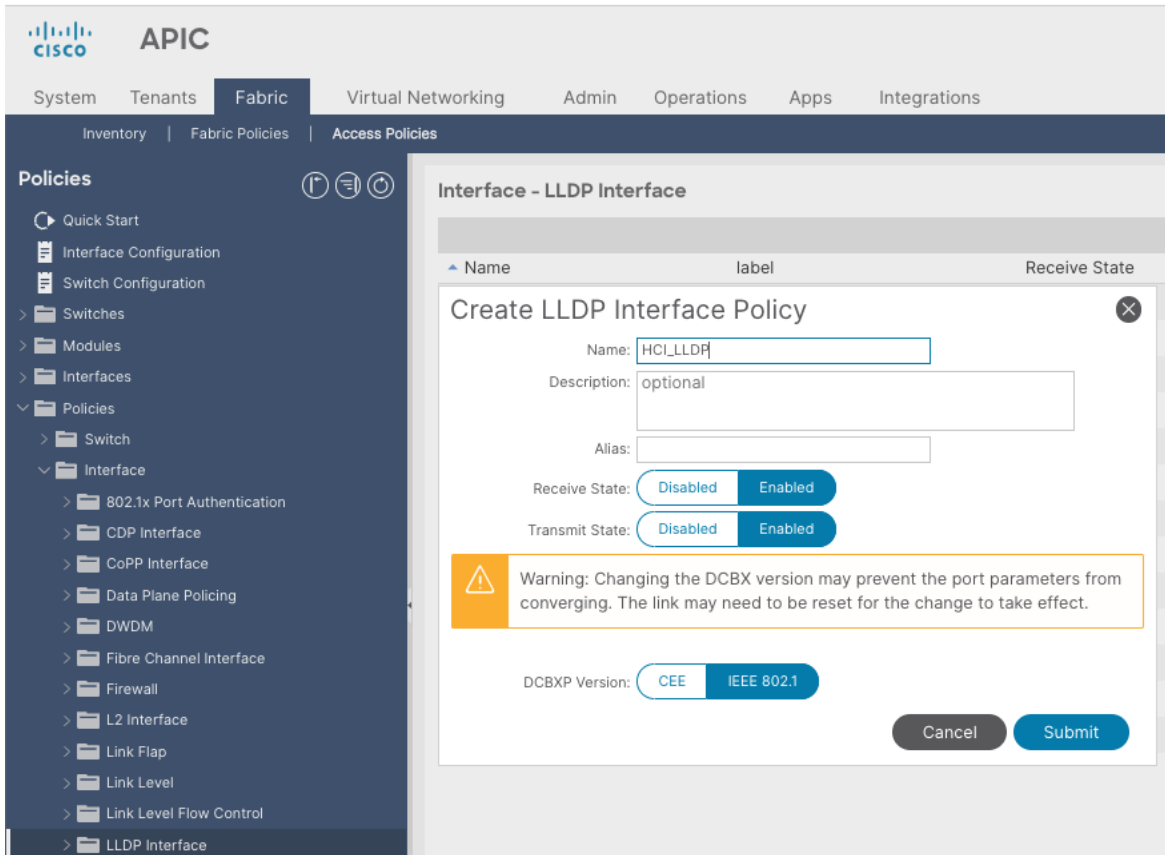

7. Click **Submit**.

## Create Interface Priority Flow Control Policy

To create an interface policy group to enable PFC on leaf downlinks, follow these steps:

1. From the APIC top navigation menu, select **Fabric > Access Policies**.
2. From the left navigation pane, expand and select **Policies > Interface > Priority Flow Control**
3. Right-click and select **Create Priority Flow Control Policy**.
4. In the Create Priority Flow Control Policy pop-up window, specify a Name (For example **PFC-Auto**) and select **Auto**. (To include PFC configuration state via DCBX protocol, it needs to be set to Auto.)

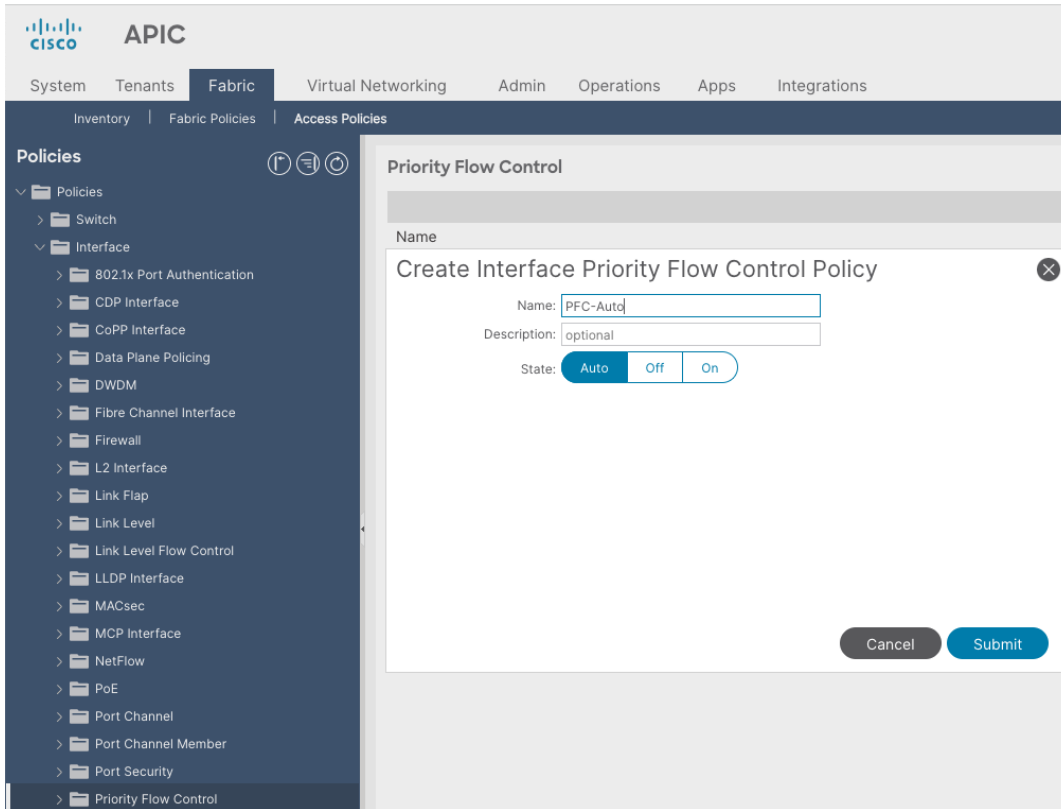

5. Click **Submit**.

## Create Interface Policy Group for Interfaces connected to Azure Local servers

To create an interface policy group to connect to external gateways outside the ACI fabric, follow these steps:

1. From the APIC top navigation menu, select **Fabric > Access Policies**.
2. From the left navigation pane, expand and select **Interfaces > Leaf Interfaces > Policy Groups > Leaf Access Port**.
3. Right-click and select **Create Leaf Access Port Policy Group**.
4. In the Create Leaf Access Port Policy Group pop-up window, specify a Name (For example **Individual-HCI**) and the applicable interface policies from the drop-down list for each field.
5. For the Attached Entity Profile, LLDP Policy and Priority Flow Control fields, select the previously created AAEP, LLDP policy and Priority Flow Control policy (For example, **HCI\_AAEP**, **HCI\_LLDP** and **PFC-auto**).

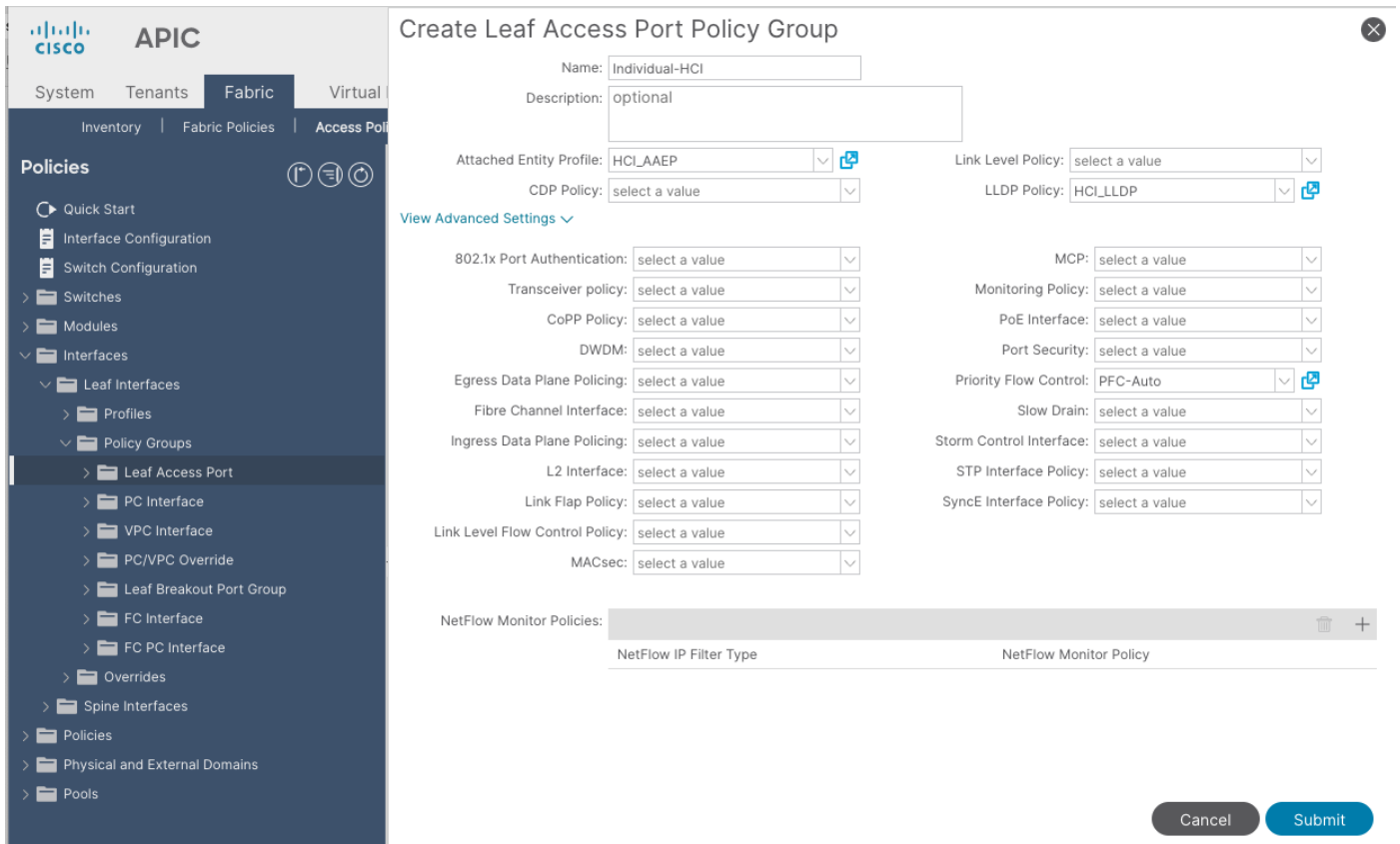

6. Click **Submit**.

## Associate the Interface Policy Group to the Leaf Interfaces Connected to Azure Local servers

To configure leaf interfaces connected to Azure Local servers, follow these steps:

1. From the APIC top navigation menu, select **Fabric > Access Policies**.
2. From the left navigation pane, select **Interface Configuration**.
3. From the right pane, right-click **Actions** and select **Configure Interfaces**.

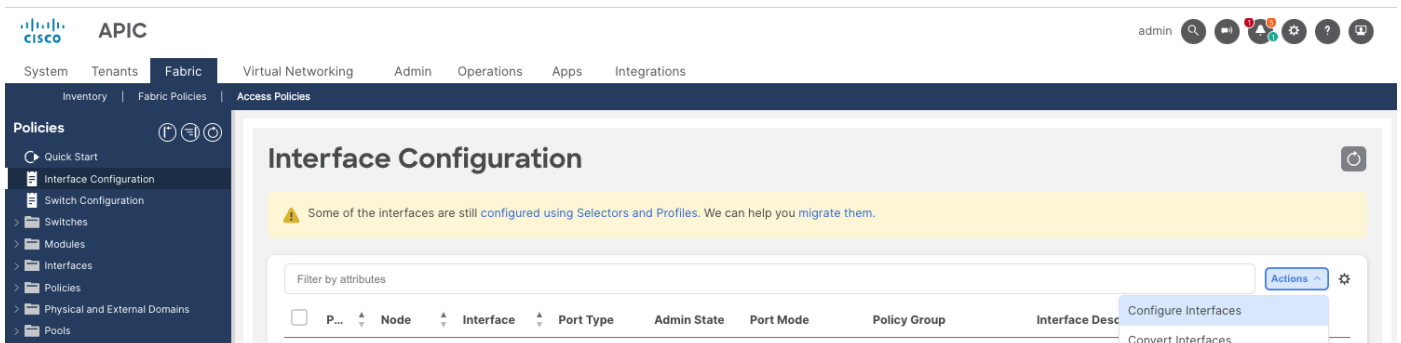

4. In the **Configure interfaces** window, select the following options.

- i. Node Type: **Leaf**
- ii. Port Type: **Access**
- iii. Interface Type: **Ethernet**

iv. Interface Aggregation Type: **Individual**

5. Click **Select Node**. In the Select Nodes pop-up window, select leaf nodes to connect Azure Local servers (For example, Node 101-102) and click **OK**.
6. Specify the Leaf interfaces to connect Azure Local servers (For example, 1/11-12).

The screenshot shows the 'Configure Interfaces' configuration page. The 'General' tab is active. Under 'Node Type', 'Leaf' is selected. Under 'Port Type', 'Access' is selected. Under 'Interface Type', 'Ethernet' is selected. Under 'Interface Aggregation Type', 'Individual' is selected. The 'Node' field contains '101-102' and has a 'Select Node' button. The 'Interfaces For All Switches' field contains '1/11-12'. The 'Leaf Access Port Policy Group' field is empty and has a red asterisk and a 'Required' label.

7. Click **Select Leaf Access Port Policy Group**. In the Select Leaf Access Port Policy Group pop-up window, select the previously created Leaf Access Port Policy Group (For example, **Individual-HCI**) from the list, and click **Select**.



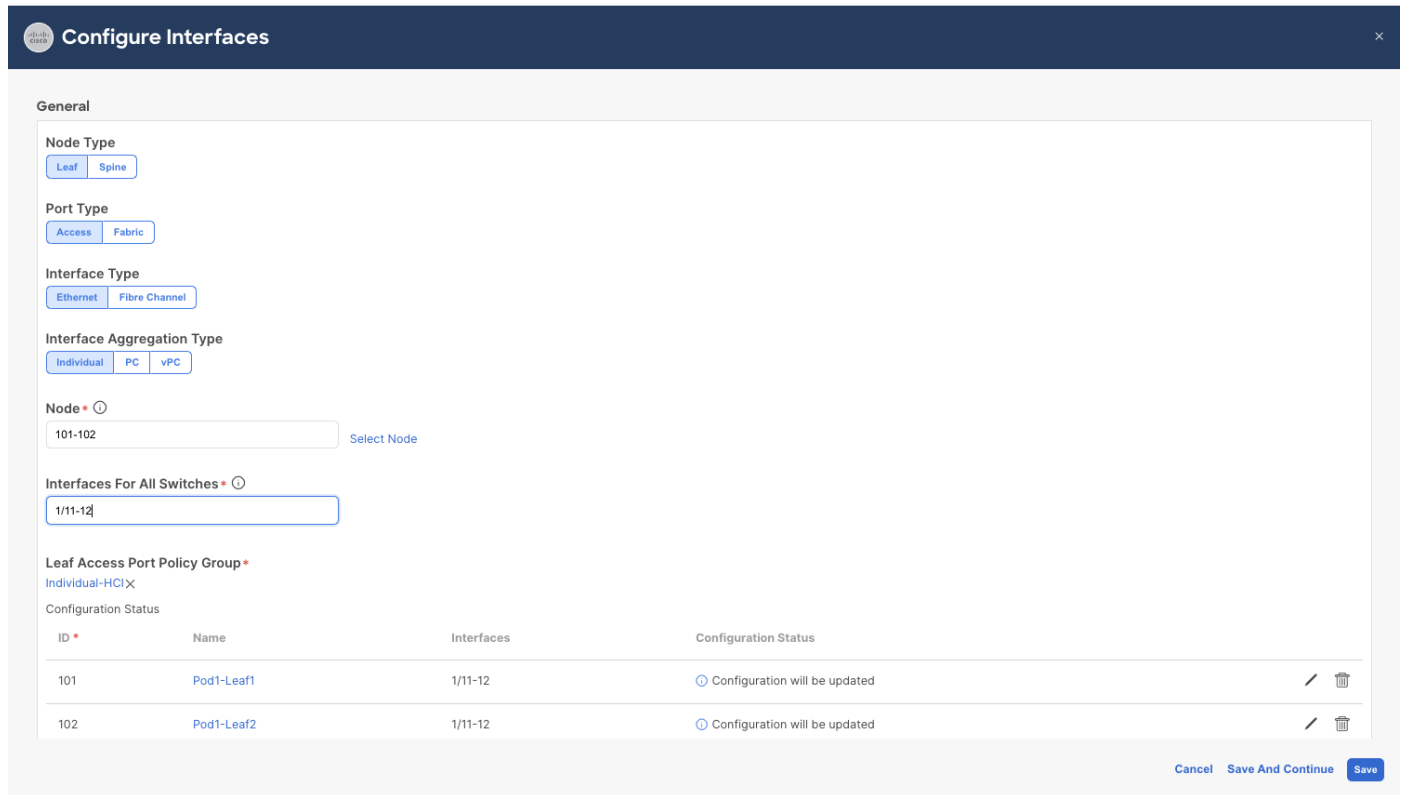

8. Click **Save**.

## Configure QoS

The table below summarizes the host network QoS recommendation from Microsoft. Please refer to the Microsoft document for details: <https://learn.microsoft.com/en-us/azure/azure-local/concepts/host-network-requirements>.

**Table 7. Azure Local host network QoS recommendation**

	Cluster Communication Traffic	Storage traffic	Default (Tenant and Management Networks)
Purpose	Bandwidth reservation for cluster heatbeats	Bandwidth reservation for lossless RDMA communication for Storage Spaces Direct	For all other traffic such as tenant networks.
Flow Control (PFC enabled)	No	Yes	No
Bandwidth reservation	1% for 25GbE or higher RDMA networks 2% for 10GbE or lower RDMA networks	50%	Default (no host configuration required)

Based on the recommendation, this document uses the following ACI QoS configurations as an example, which are the same as the bandwidth reservation and Priority configurations that are used in [the Cisco UCS C240 M6 Solution for Microsoft Azure Local](#).

- Level1 for RDMA (storage) traffic (Traffic comes with Cos 4 marked by Azure Local)
  - PFC is enabled

- Bandwidth reservation: 50%
- ETS (Weighted round robin in ACI)
- Level2 for cluster communication (Traffic comes with Cos 5 marked by Azure Local)
  - PFC is not enabled
  - Bandwidth reservation: 1%
  - ETS (Weighted round robin in ACI)
- Level3(default) for VM traffic and management traffic (Other traffic)
  - PFC is not enabled
  - Bandwidth reservation: 49%
  - ETS (Weighted round robin in ACI)

The following figure illustrates an example of QoS configuration.

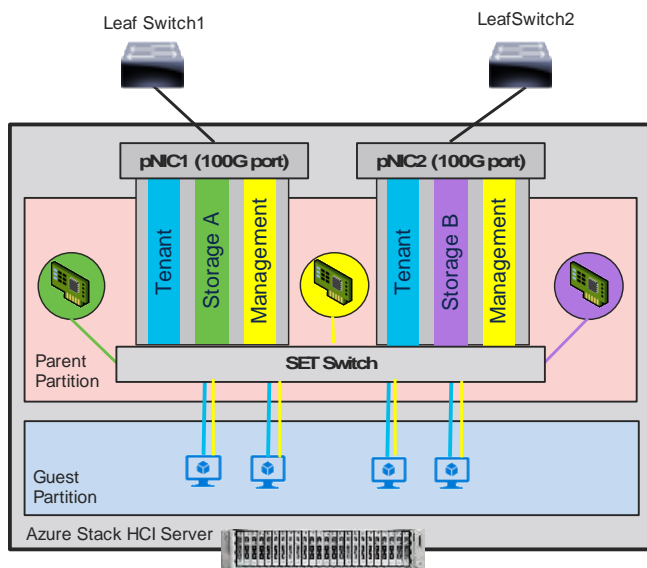

QoS config on ACI fabrics

- Level1: For Storage EPGs Cos 4. 50%. PFC is enabled for Cos 4.
- Level2: For Storage EPGs Cos 5. 1%.
- Level3(default): default configuration for other EPGs. 49%

QoS config on AzureStack HCI

- Storage: 50% (Priority 4 = Cos 4)
- Cluster: 1% (Priority 5 = Cos 5)
- Others: 49%

(Cluster traffic is also carried over Storage networks: Storage A and Storage B)

**Figure 20.**  
ACI QoS configuration for Azure Local

The Cisco ACI fabric supports six user-configurable QoS levels (Level1-6) as well as two levels reserved for fabric control traffic, SPAN, and traceroute traffic.

**Table 8. Cisco ACI QoS Levels**

Class of Service	QoS Group Used by DCBX (ETS configuration and ETS recommendation) *	Traffic Type	Doc1p (Cos) Marking in VXLAN Header	DEI Bit**
0	0	Level 3 (default)	0	0
1	1	Level 2	1	0
2	2	Level 1	2	0

Class of Service	QoS Group Used by DCBX (ETS configuration and ETS recommendation) *	Traffic Type	Doc1p (Cos) Marking in VXLAN Header	DEI Bit**
4	7	Level 6	2	1
5	6	Level 5	3	1
6	5	Level 4	5	1
3	3	APIC Controller	3	0
9	Not Advertised	SPAN	4	0
8 (SUP)	4	Control	5	0
8 (SUP)	4	Traceroute	6	0
7	Not Advertised	Copy Service	7	0

\* In IEEE DCBX PFC configuration LLDP TLV, the Priority value is the associated Cos value regardless of which Level (Level 1-6) the PFC is enabled. The configuration section below includes an example.

\*\*The Drop Eligible Indicator (DEI) bit is a 1-bit field that is used to indicate frames that are eligible to be dropped during traffic congestion. The CoS value (3 bits) + DEI value (1 bit) represents the QoS class.

## Configure QoS Classes

To configure Cisco ACI QoS classes, follow these steps:

1. From the APIC top navigation menu, select **Fabric > Access Policies**.
2. From the left navigation pane, expand **Policies > Global > QoS Class** and select one of the levels. (For example, **level1** for storage traffic).
3. In the **Scheduling algorithm** field, from the drop-down list, choose **Weighted round robin**. This is the default configuration.
4. In the Bandwidth allocation (in %) field, specify a number. (For example, **50** for storage traffic).
5. If PFC is not required in the class, leave PFC Admin State field unchecked.
6. If PFC is required in the class,
  - a. Check **PFC Admin State** field
  - b. In the No Drop-Cos field, select Cos value (For example, **Cos 4** for storage traffic)
  - c. In the scope field, select **Fabric-wide PFC**. (If the traffic is within the same leaf, IntraTor PFC is also fine)

The screenshot shows the Cisco Fabric configuration page for 'QOS Class Policy - Level1'. The left-hand navigation pane is expanded to show 'Policies' > 'QOS Class' > 'Level1'. The main configuration area includes the following settings:

- QoS Class: Level1
- Admin State: Enabled
- MTU: 9216
- Minimum buffers: 0
- Congestion Algorithm: Tail drop / Weighted random early detection
- Queue control method: Dynamic
- Scheduling algorithm: Weighted round robin
- Bandwidth allocated (in %): 50
- PFC Admin State:
- No-Drop-CoS: cos 4
- Scope: Fabric-wide PFC / IntraTor PFC

At the bottom of the configuration area, there are three buttons: 'Show Usage', 'Reset', and 'Submit'.

7. Click **Submit**.

With this QoS configuration and LLDP IEEE DCBX configuration, the following values are set in LLDP.

- IEEE ETS Configuration and IEEE ETS Recommendation
  - PGID for Prio 4: 2 (because Cos 4 is selected and level1 is QoS group 2)
  - Bandwidth for PGID 2: 50 (level1 is QoS group 2)
  - TSA for Traffic Class 2: Enhanced Transmission Selection (level1 is QoS group 2)
- IEEE Priority Flow Control Configuration
  - PFC for Priority 4: Enabled (because Cos 4 is selected, and PFC is enabled)

```

IEEE - ETS Configuration
 1111 111. .... = TLV Type: Organization Specific (127)
 .... 0001 1001 = TLV Length: 25
 Organization Unique Code: 00:80:c2 (IEEE)
 IEEE 802.1 Subtype: ETS Configuration (0x00)
 0... .. = Willing: No
 .0... .. = Credit-Based Shaper: Not supported
 .... 110 = Maximum Number of Traffic Classes: 6 (0x6)
 0000 .... = PGID for Prio 0: 0
 .... 0000 .... = PGID for Prio 1: 0
 .... 0000 .... = PGID for Prio 2: 0
 .... 0000 .... = PGID for Prio 3: 0
 0010 .... = PGID for Prio 4: 2
 .... 0000 .... = PGID for Prio 5: 0
 .... 0000 .... = PGID for Prio 6: 0
 .... 0000 .... = PGID for Prio 7: 0
 Bandwidth for PGID 0: 0
 Bandwidth for PGID 1: 0
 Bandwidth for PGID 2: 50
 Bandwidth for PGID 3: 0
 Bandwidth for PGID 4: 0
 Bandwidth for PGID 5: 0
 Bandwidth for PGID 6: 0
 Bandwidth for PGID 7: 0
 TSA for Traffic Class 0: Enhanced Transmission Selection (2)
 TSA for Traffic Class 1: Enhanced Transmission Selection (2)
 TSA for Traffic Class 2: Enhanced Transmission Selection (2)
 TSA for Traffic Class 3: Strict Priority (0)
 TSA for Traffic Class 4: Strict Priority (0)
 TSA for Traffic Class 5: Enhanced Transmission Selection (2)
 TSA for Traffic Class 6: Enhanced Transmission Selection (2)
 TSA for Traffic Class 7: Enhanced Transmission Selection (2)

```

```

IEEE - Priority Flow Control Configuration
 1111 111. .... = TLV Type: Organization Specific (127)
 .... 0000 0110 = TLV Length: 6
 Organization Unique Code: 00:80:c2 (IEEE)
 IEEE 802.1 Subtype: Priority Flow Control Configuration (0x00)
 0... .. = Willing: No
 .0... .. = MACsec Bypass Capability: Not capable
 .... 1000 = Max PFC Enabled Traffic Classes: 8
 .... 0... = PFC for Priority 0: Disabled
 .... 0... = PFC for Priority 1: Disabled
 .... 0... = PFC for Priority 2: Disabled
 .... 0... = PFC for Priority 3: Disabled
 ...1 .... = PFC for Priority 4: Enabled
 .... 0... = PFC for Priority 5: Disabled
 .... 0... = PFC for Priority 6: Disabled
 .... 0... = PFC for Priority 7: Disabled

```

Level1 -> PGID 2: 50% (Storage traffic)  
Cos 4 -> PFC enabled

By default, all “PGID for Pri 0” to “PGID for Pri 7” are set to 0 and all “PFC for Priority 0” to “PFC for Priority 7” are set to Disabled. If PFC is enabled, the value for the specific priority (Cos value) is updated. (“PGID for Pri 4: 2” and “PFC for Priority 4” in the example above.)

8. Repeat step 2 –7 for the level for cluster communication traffic. For example, **level2** for cluster communication traffic with **1%** bandwidth reservation configuration is the following:

- QoS Class: Level2
- Scheduling algorithm: Weighted round robin (default configuration)
- Bandwidth allocation (in %): 1
- PFC Admin State: unchecked
  - With this QoS configuration and LLDP IEEE DCBX configuration, the following values are set in LLDP. There is no change on PGID and PFC for Priority 0–3 and 5–7.
- IEEE ETS Configuration and IEEE ETS Recommendation
  - a. Bandwidth for PGID 1: 1 (because level2 is QoS group 1 based on table 8)
  - b. TSA for Traffic Class 1: Enhanced Transmission Selection

9. Repeat step 2 –7 for the level other traffic. For example, **level3(Default)** for VM traffic with **49%** bandwidth reservation configuration is the following:

- QoS Class: level3(Default)
- Scheduling algorithm: Weighted round robin (default configuration)
- Bandwidth allocation (in %): 49
- PFC Admin State: unchecked

With this QoS configuration and LLDP IEEE DCBX configuration, the following values are set in LLDP. There is no change on PGID and PFC for Priority 0-3 and 5-7.

- IEEE ETS Configuration and IEEE ETS Recommendation
  - a. Bandwidth for PGID 0: 10 (because level3 is QoS group 0 based on table 8)
  - b. TSA for Traffic Class 0: Enhanced Transmission Selection

```

IEEE - ETS Configuration
1111 111. .... = TLV Type: Organization Specific (127)
.... ..0 0001 1001 = TLV Length: 25
Organization Unique Code: 00:00:c2 (IEEE)
IEEE 802.1 Subtype: ETS Configuration (0x09)
0... .. = Willing: No
..0. .... = Credit-Based Shaper: Not supported
.... ..110 = Maximum Number of Traffic Classes: 6 (0x6)
0000 .... = PGID for Prio 0: 0
.... ..0000 = PGID for Prio 1: 0
.... ..0000 = PGID for Prio 2: 0
.... ..0000 = PGID for Prio 3: 0
0010 .... = PGID for Prio 4: 2
.... ..0000 = PGID for Prio 5: 0
.... ..0000 = PGID for Prio 6: 0
.... ..0000 = PGID for Prio 7: 0

Bandwidth for PGID 0: 49
Bandwidth for PGID 1: 1
Bandwidth for PGID 2: 50
Bandwidth for PGID 3: 0
Bandwidth for PGID 4: 0
Bandwidth for PGID 5: 0
Bandwidth for PGID 6: 0
Bandwidth for PGID 7: 0

TSA for Traffic Class 0: Enhanced Transmission Selection (2)
TSA for Traffic Class 1: Enhanced Transmission Selection (2)
TSA for Traffic Class 2: Enhanced Transmission Selection (2)
TSA for Traffic Class 3: Strict Priority (0)
TSA for Traffic Class 4: Strict Priority (0)
TSA for Traffic Class 5: Enhanced Transmission Selection (2)
TSA for Traffic Class 6: Enhanced Transmission Selection (2)
TSA for Traffic Class 7: Enhanced Transmission Selection (2)
    
```

```

IEEE - Priority Flow Control Configuration
1111 111. .... = TLV Type: Organization Specific (127)
.... ..0 0000 0110 = TLV Length: 6
Organization Unique Code: 00:00:c2 (IEEE)
IEEE 802.1 Subtype: Priority Flow Control Configuration (0x0b)
0... .. = Willing: No
..0. .... = MACsec Bypass Capability: Not capable
.... ..1000 = Max PFC Enabled Traffic Classes: 8
.... ..0 = PFC for Priority 0: Disabled
.... ..0 = PFC for Priority 1: Disabled
.... ..0 = PFC for Priority 2: Disabled
.... ..0 = PFC for Priority 3: Disabled
0... ..1 = PFC for Priority 4: Enabled
.... ..0 = PFC for Priority 5: Disabled
.... ..0 = PFC for Priority 6: Disabled
.... ..0 = PFC for Priority 7: Disabled
    
```

Level1 -> PGID 2: 50% (Storage traffic)  
 Cos 4 -> PFC enabled  
 Level2 -> PGID 1: 1% (Cluster communication traffic)  
 Level3 -> PGID 0: 49% (VM traffic)

### Configure Custom QoS Policy

ACI has multiple QoS classification options that are illustrated in the figure below.

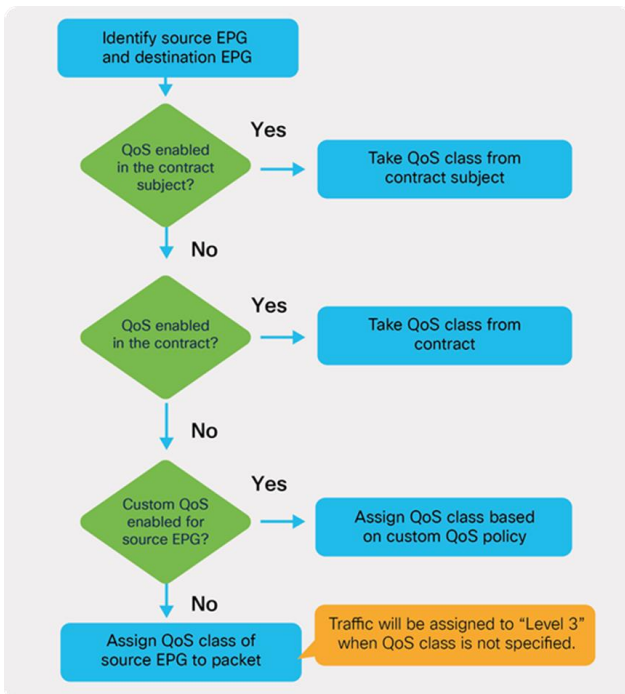

**Figure 21.**  
ACI QoS configuration priority

This document uses QoS Class configuration at EPGs for tenant and management networks (default level3), and uses the custom QoS policy configuration at EPG for storage and cluster communication network (level1 for storage with Cos 4 and level2 for cluster communication with Cos 5).

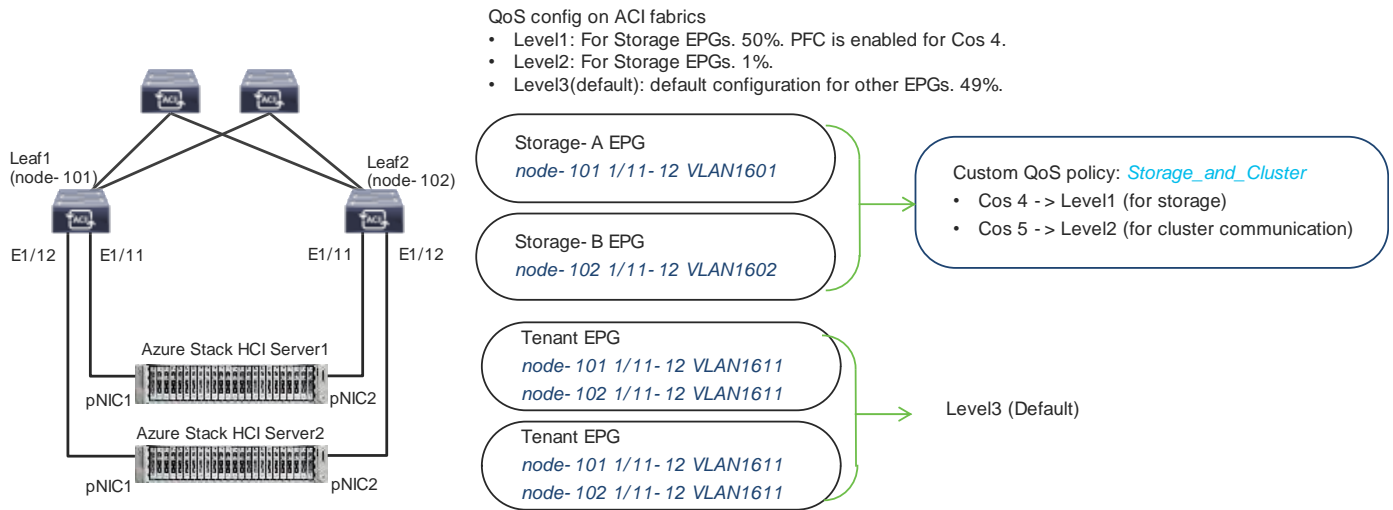
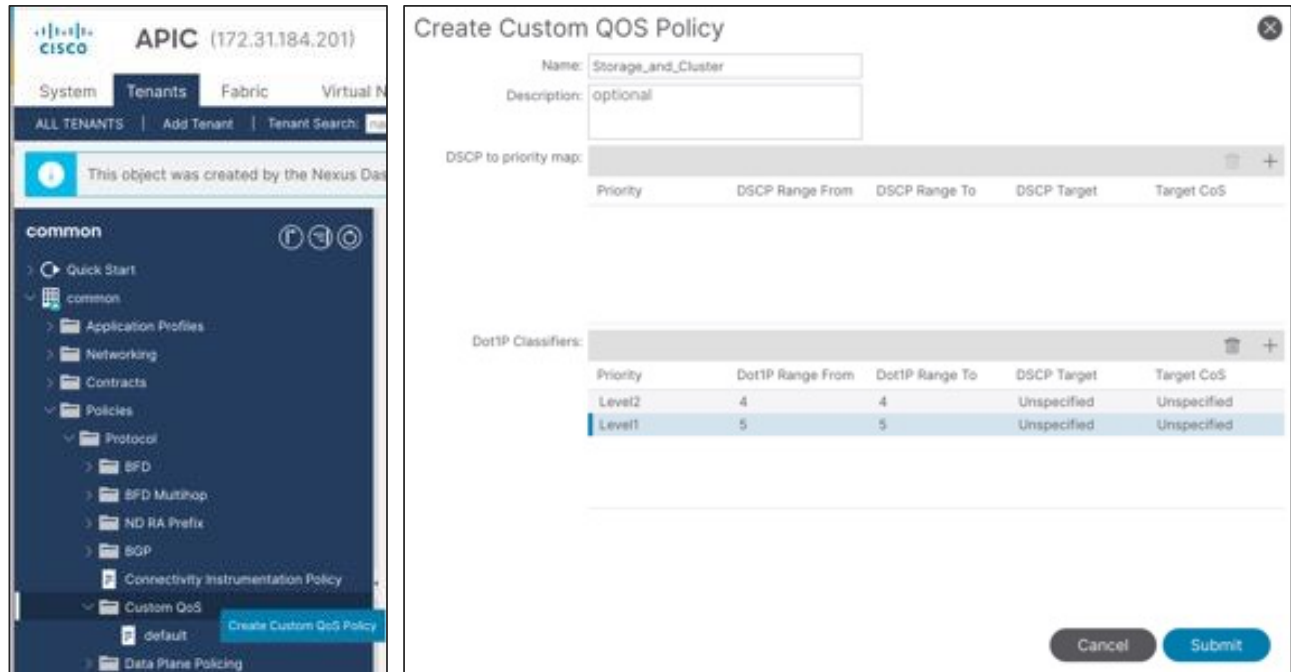

**Figure 22.**  
ACI QoS and EPG configuration example

To configure a Custom QoS policy, follow these steps:

1. From the APIC top navigation menu, select **Tenants > common** (or select an existing tenant where you want to configure EPGs).
2. From the left navigation pane, expand and select **Policies > Protocol > Custom QoS**.
3. Right-click and select **Create Custom QoS Policy** to open the **Create Custom QOS Policy** pop-up window.
4. In the **Name** field, specify a Name (For example, **Storage\_and\_Cluster**).
5. In the **Dot1P Classifiers** field, click **+** and configure the followings:
  - a. Priority (In this example, select **level2** from the drop-down list for storage traffic)
  - b. Dot1P Range From and To (In this example, specify **4** for storage traffic)
6. Click **Update**.
7. Repeat step 5-6 for cluster communication traffic. (In this example, **level1 with 5** for cluster communication traffic.)





8. Click **Submit**.

This Custom QoS Policy is referred to in the next step (Configuring EPGs)

## Configure EPGs

The following EPGs are created in this section.

- Tenant EPGs for VMs
- Management EPG for management network
- Storage EPGs for storage networks
- Configure contracts
- Add consumer and provider EPGs to the contract

## Configure Tenant EPGs

To configure a tenant EPG for Azure Local VMs, follow these steps:

1. From the APIC top navigation menu, select **Tenants > Add Tenant**
2. In the **Create Tenant** dialog box, specify a Name (For example, **HCI\_tenant1**).
3. In the **VRF Name** field, enter the VRF name (For example, **VRF1**).
4. Check **Create A Bridge Domain** and click **Next**.



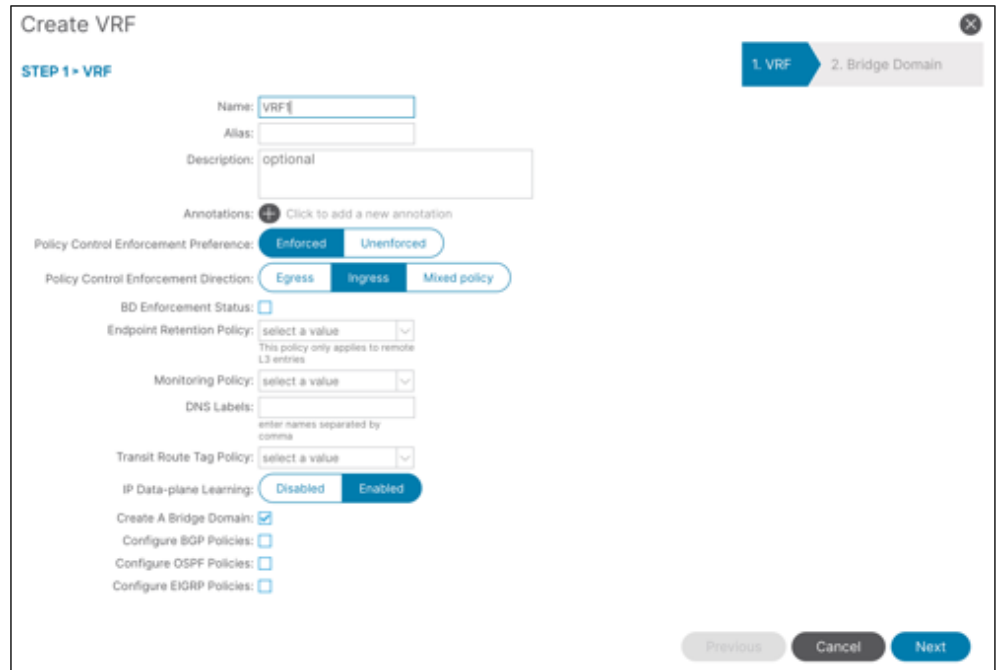
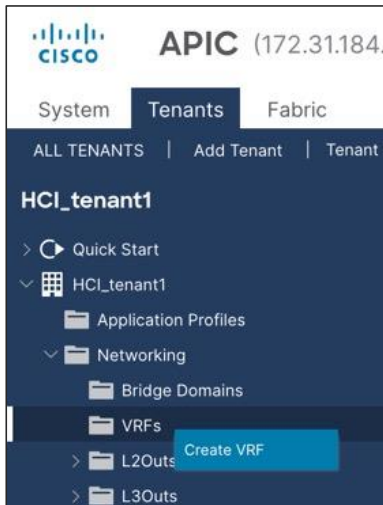

5. In the **Name** field, specify a Name (For example, **BD1**) and click **Finish**.

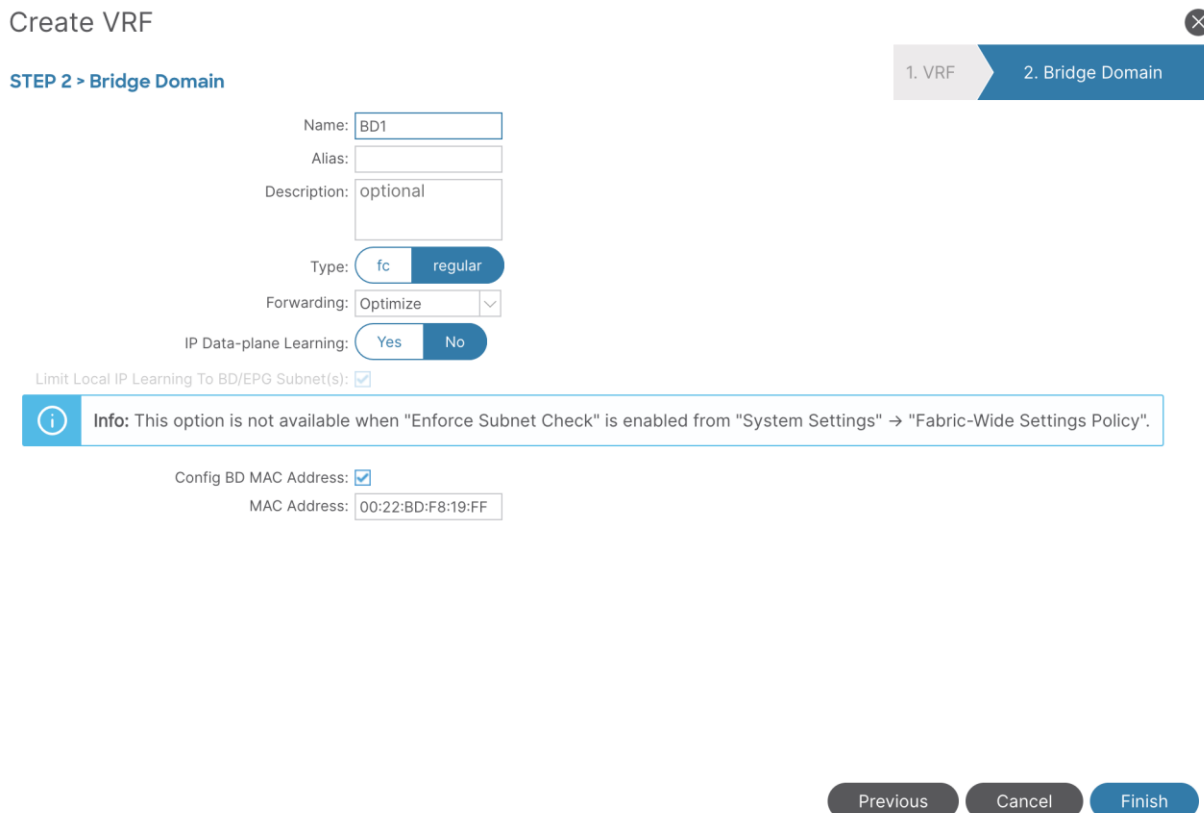

6. To create an anycast gateway IP address on the bridge domain, in the Navigation pane, expand the created bridge domain (**BD1**) under **Networking > Bridge Domains**.

7. Right-click Subnets and choose **Create Subnet**.

8. In the **Gateway IP** field, configure the anycast gateway IP address (In this example, **192.168.1.254/24**), and click **Submit**.

The screenshot shows the APIC interface with the 'Create Subnet' dialog box open. The dialog box is titled 'Create Subnet' and has a close button in the top right corner. The 'Gateway IP' field is set to '192.168.1.254/24'. Below this field are checkboxes for 'Treat as virtual IP address', 'Make this IP address primary', and 'Scope' (with options 'Advertised Externally' and 'Shared between VRFs'). The 'Description' field contains the text 'optional'. The 'Subnet Control' section has checkboxes for 'No Default SVI Gateway' and 'Querier IP'. The 'IP Data-plane Learning' section has two buttons: 'Disabled' (selected) and 'Enabled'. The 'L3 Out for Route Profile' and 'ND RA Prefix Policy' fields are dropdown menus with 'select a value' as the current selection. The 'Policy Tags' section has a plus sign icon and the text 'Click to add a new tag'. At the bottom right of the dialog box are 'Cancel' and 'Submit' buttons.

9. To create an Application Profile, from the left navigation pane, right-click **Application Profiles** and choose **Create Application Profile**.
10. In the **Name** field, specify a Name (For example, **AP1**) and click **Submit**.
11. To create an EPG, from the left navigation pane, expand the created Application Profile, right-click **Application EPGs** and choose **Create Application EPG**.
12. In the **Name** field, specify a Name (For example, **Web**).
13. In the **QoS class** field, from the drop-down list, choose a Level. (For example, **Level3 (Default)** for VM traffic, which is the default configuration)
14. In the **Bridge Domain** field, from the drop-down list, choose the BD we created (In this example, **BD1**).
15. Check **Statically Link with Leaves/Paths** and click **Next**.

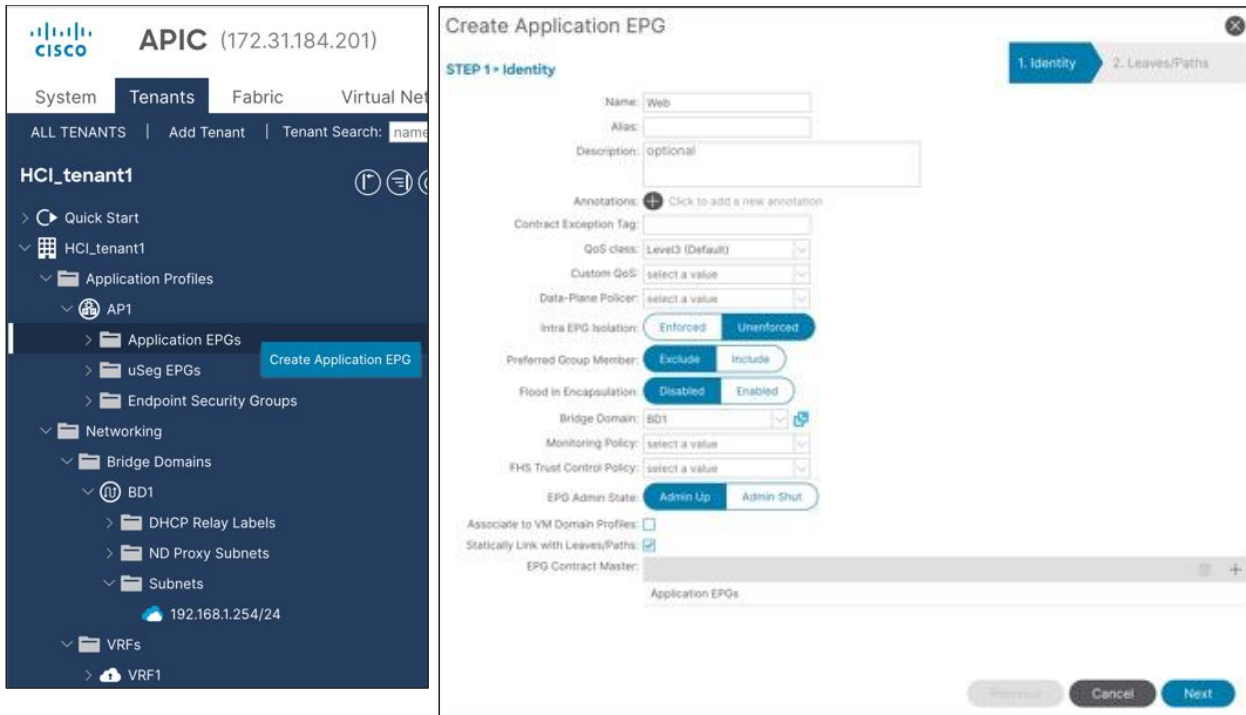

**Note:** QoS class is Level3 (Default) for the tenant EPG, which doesn't enable PFC by default.

16. In the Physical Domain field, from the drop-down list, choose the physical domain we created (In this example, **HCI\_phys**).

17. In the **Paths** field, click + and select a Path and configure Port Encap. (In this example, **Pod-1/Node-101/eth1/11** and **vlan-1611** for **Web**).

18. Repeat step 17 to add all the interfaces that are connected to Azure Local servers in the cluster. (In this example, **Node-101/eth1/11-12** and **Node-102/eth1/11-12** with **vlan-1611** for **Web**).

19. Repeat step 11-18 for other tenant EPGs (For example, EPG **App** with **vlan-1612**).

## Configure a Management EPG

To configure Azure Local storage networking, follow these steps:

1. From the APIC top navigation menu, select **Tenants > common** (or select an existing tenant where you want to configure a management EPG).
2. From the left navigation pane, expand and select **Networking > Bridge Domains**.
3. Right-click and select **Create Bridge Domain**.
4. In the **Name** field, specify a Name (For example, **Mgmt**) and select a VRF name (In this example, **common-VRF**).
5. Click **Next**.
6. In the **Subnets** field, click + to create subnet.
7. In the **Gateway IP** field, specify an IP (For example, **10.1.1.254/24**).
8. Click **OK**.

9. To create an EPG, from the left navigation pane, expand **Application Profiles** and select an existing Application Profile (or create a new Application Profile).
10. Right-click **Application EPGs** and select **Create Application EPG**.
11. In the **Name** field, specify a Name (For example, **Mgmt**).
12. In the **QoS class** field, from the drop-down list, choose a Level. (For example, **Level3(Default)** for management traffic).
13. In the **Bridge Domain** field, from the drop-down list, choose the BD we created (In this example, **Mgmt**).
14. Check **Statically Link with Leaves/Paths** and click **Next**.
15. In the **Physical Domain** field, from the drop-down list, choose the physical domain we created (In this example, **HCI\_phys**).
16. In the **Paths** field, click **+** and select a Path and configure Port Encap (In this example, **Pod-1/Node-101/eth1/11** and **vlan-1600** for **Mgmt**). If native VLAN (untagged) is used for management network, select **Trunk (Native)** in the Mode field.
17. Repeat step 16 for other Azure Local server interfaces in the cluster. (In this example, **Node-101/eth1/11-12** and **Node-102/eth1/11-12** with **vlan-1600** for **Mgmt**).

## Configure Storage EPGs

To configure Azure Local storage networking, follow these steps:

1. From the APIC top navigation menu, select **Tenants > common** (or select an existing tenant where you want to configure storage EPGs).
2. From the left navigation pane, expand and select **Networking > Bridge Domains**.
3. Right-click and select **Create Bridge Domain**.
4. In the **Name** field, specify a Name (For example, **Storage-A**) and select a VRF name (In this example, **common-VRF**).
5. In the **Forwarding** field, from the drop-down list, choose **Custom**.
6. In the **L2 Unknown Unicast** field, from the drop-down list, choose **Flood**.
7. Click **Next**.
8. Uncheck **Unicast Routing** checkbox to disable Unicast Routing and click **Next**.
9. Click **Finish**.
10. To create an EPG, from the left navigation pane, expand **Application Profiles** and select an existing Application Profile (or create a new Application Profile).
11. Right-click **Application EPGs** and select **Create Application EPG**.
12. In the **Name** field, specify a Name (For example, **Storage-A**).
13. In the **Custom QoS** field, from the drop-down list, choose the Custom QOS Policy we created (In this example, **Storage\_and\_Cluster**).

14. In the **Bridge Domain** field, from the drop-down list, choose the BD we created (In this example, **Storage-A**).

15. Check **Statically Link with Leaves/Paths** and click **Next**.

Create Application EPG

STEP 1 > Identity

1. Identity 2. Leaves/Paths

Name: Storage-A

Alias:

Description: optional

Annotations: + Click to add a new annotation

Contract Exception Tag:

QoS class: Level3 (Default)

Custom QoS: Storage\_and\_Cluster

Data-Plane Policer: select a value

Intra EPG Isolation: Enforced Unenforced

Preferred Group Member: Exclude Include

Flood in Encapsulation: Disabled Enabled

Bridge Domain: Storage-A

Monitoring Policy: select a value

FHS Trust Control Policy: select a value

EPG Admin State: Admin Up Admin Shut

Associate to VM Domain Profiles:

Statically Link with Leaves/Paths:

EPG Contract Master:

Application EPGs

Previous Cancel Next

16. In the **Physical Domain** field, from the drop-down list, choose the physical domain we created (In this example, **HCI\_phys**).

17. In the **Paths** field, click + and select a Path and configure Port Encap (In this example, **Pod-1/Node-101/eth1/11** and **vlan-107** for **Storage-A**).

18. Repeat step 17 for other Azure Local servers in the cluster (In this example, **Pod-1/Node-102/eth1/11** and **vlan-107** for **Storage-A**).

19. Repeat step 2-21 for the second storage EPG (For example, **Storage-B** and EPG **Storage-B** using the created Custom QoS **Storage\_and\_Cluster**, physical domain **HCI\_phys** and Path **Pod-1/Node-101/eth1/12** and **Pod-1/Node-102/eth1/12** with **vlan-207**).

## Configure Contracts

To configure a contract, follow these steps:

1. From the APIC top navigation menu, select **Tenants** and select a tenant where the provider EPG resides. For example, select tenant **HCI\_tenant1** for a contract between Web and App EPGs.
2. From the left navigation pane, expand and select **Contracts**.
3. Right-click and select **Create Contract**.
4. In the **Name** field, specify a Name (For example, **Web-to-App**).

- In the **Scope** field, from the drop-down list, choose a Scope (In this example, **VRF**. If it's inter-tenant contract, select **Global**.)
- In the **Subjects** field, click + and specify a contract subject name. (For example, **Subject1**.)
- In the **Filter** field, click + and choose an existing filter (or create a new filter from the drop-down list).
- Click **Update** and repeat step 7, if you have another filter.
- Click **OK**.

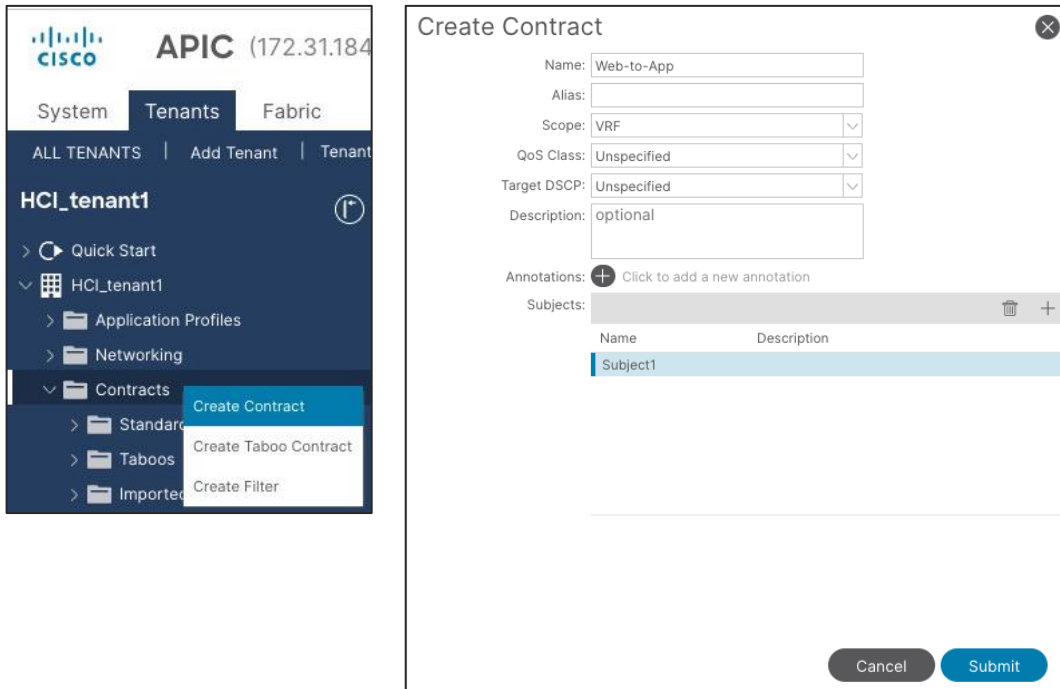

- Click **Submit**.
- Repeat step 1-10 if you have another contract.

### Add Consumer/Provider EPGs to the contract

To add an EPG to a contract, follow these steps:

- From the APIC top navigation menu, select **Tenants** and select a tenant where the EPG resides. For example, select tenant **HCI\_tenant1** for a contract between Web and App EPGs.
- From the left navigation pane, expand **Application Profiles** and expand the Application Profile where the EPG resides.
- Expand **Application EPGs** and expand the EPG. (For example, **Web**).
- Right-click **Contracts** and select **Add Provided Contract** or **Add Consumed Contract** depending on whether the EPG is the provider or the consumer. (In this example, Web EPG is the consumer to the contract).
- In the **Contract** field, from the drop-down list, choose the contract we created (In this example, **Web-to-App**).

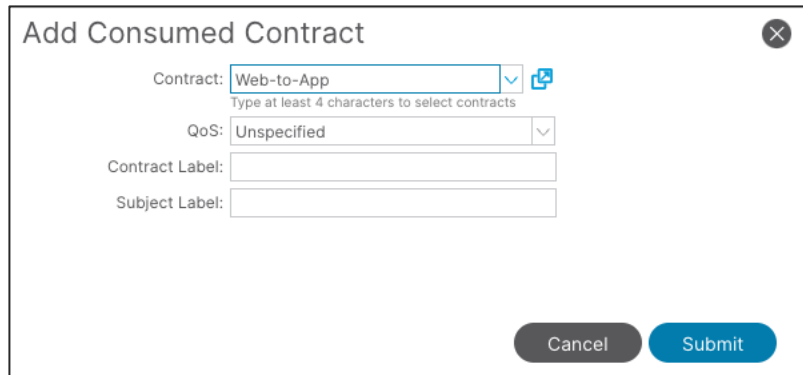
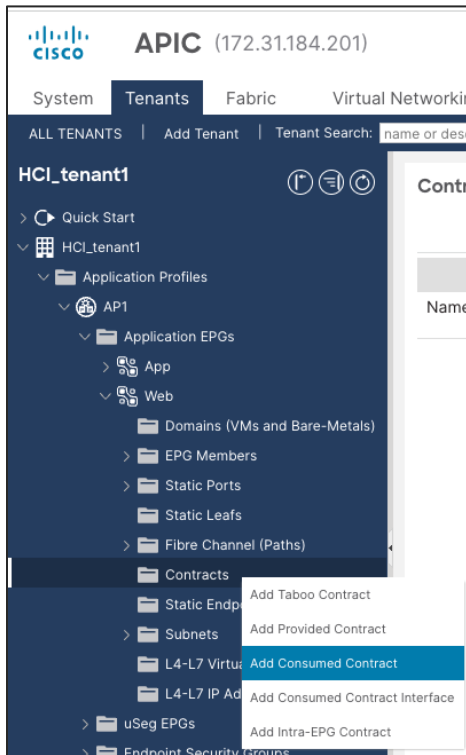

6. Click **Submit**.

7. Repeat step 1-6 for other EPGs.

## Cisco NX-OS based Fabric configuration for Azure Local

This section explains how to configure Cisco NX-OS based VXLAN fabric for Azure Local servers with the assumption that the VXLAN fabric managed by Cisco NDFC already exists in the customer's environment. This document does not cover the configuration required to bring the initial VXLAN fabric. For building IGP based Underlay and iBGP based Overlay (BGP EVPN), **Data Center VXLAN EVPN** fabric template should be used.

This document does not cover NX-OS based traditional classical LAN fabric however, the same workflow can be followed for traditional classical LAN fabrics. NDFC comes with **Enhanced Classic LAN (ECL)** fabric template for building NX-OS based traditional classical LAN fabrics.

The overall configuration can be categorized as below:

- Configure QoS
- LLDP configuration
- Configuring leaf interfaces connected to Azure Local servers
- Configuration of Networks and VRFs
- Configuring External connectivity

### Configure QoS

The QoS requirement for Azure Local host is same for both ACI and NX-OS based fabrics. For more details, please refer [Table 7 Azure Local host network QoS recommendation](#).

Only the switches connected to Azure Local servers need to have the required QoS configurations as shown below:

Create Class-maps to classify RDMA and cluster communication traffic on ingress interface based on CoS markings set by the Azure Local servers -

```
class-map type qos match-all RDMA
  match cos 4
class-map type qos match-all CLUSTER-COMM
  match cos 5
```

Once the traffic is classified (based on CoS value set by the Server) it needs to be mapped to the respective QoS Groups -

```
policy-map type qos AzS_HCI_QoS
  class RDMA
    set qos-group 4
  class CLUSTER-COMM
    set qos-group 5
```

Define Network QoS classes and match traffic based on the QoS Groups -

```
class-map type network-qos RDMA_CL_Map_NetQos
  match qos-group 4
class-map type network-qos Cluster-Comm_CL_Map_NetQos
  match qos-group 5
```

Create Network QoS policy to enable PFC for RDMA traffic and set Jumbo MTU -

```
policy-map type network-qos QOS_NETWORK
  class type network-qos RDMA_CL_Map_NetQos
    pause pfc-cos 4
    mtu 9216
  class type network-qos Cluster-Comm_CL_Map_NetQos
    mtu 9216
  class type network-qos class-default
    mtu 9216
```

Configure Queuing policy to enable ECN for RDMA traffic and bandwidth allocation for other classes -

```
policy-map type queuing QOS_EGRESS_PORT
  class type queuing c-out-8q-q-default
    bandwidth remaining percent 49
  class type queuing c-out-8q-q1
    bandwidth remaining percent 0
  class type queuing c-out-8q-q2
    bandwidth remaining percent 0
  class type queuing c-out-8q-q3
    bandwidth remaining percent 0
  class type queuing c-out-8q-q4
    bandwidth remaining percent 50
    random-detect minimum-threshold 300 kbytes maximum-threshold 300 kbytes drop-probability 100
weight 0 ecn
  class type queuing c-out-8q-q5
    bandwidth percent 1
  class type queuing c-out-8q-q6
    bandwidth remaining percent 0
  class type queuing c-out-8q-q7
    bandwidth remaining percent 0
```

Apply the Queuing and Network QoS policies to System QoS -



```

system qos
  service-policy type queuing output QOS_EGRESS_PORT
  service-policy type network-qos QOS_NETWORK

```

The above QoS configuration is only required on the Leaf switches that are used to connect Azure Local servers. There is no requirement of fabric-wide QoS configuration as long as all the Azure Local servers of same cluster are connected to same vPC pair of Leafs.

The steps to configure the QoS policies through NDFC are as follows:

**Step 1:** Select both the Leaf switches (connecting to Azure Local) and create a Group Policy using **switch\_freemform** policy template and paste all the QoS related configuration (shown above) in Switch Freeform Config box.

To create a policy, go to Fabric **Detailed View > Policies** Tab.

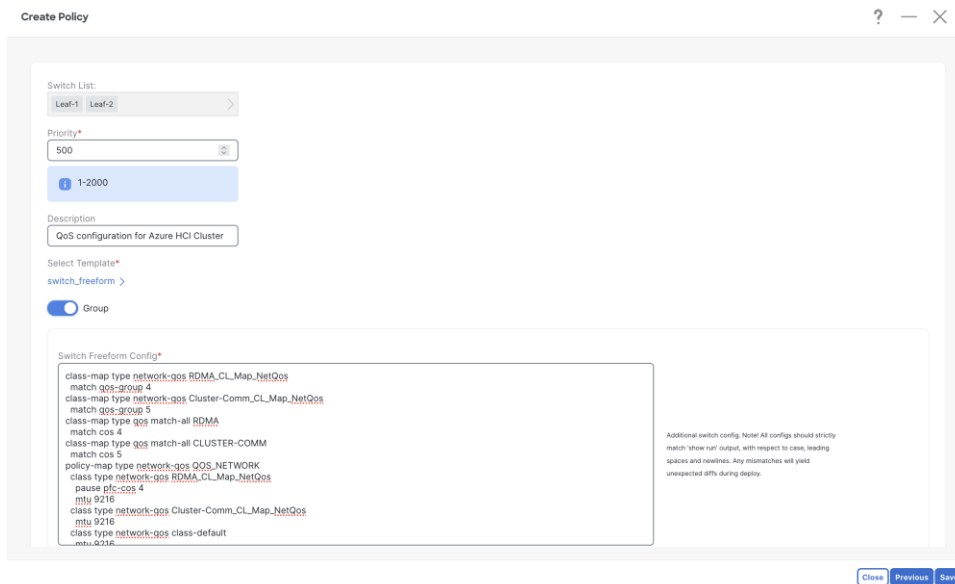

Click on **Save** and you would be returned to **Policy** tab. From Policy tab page select the policy just created and click on **Push** button from **Actions** drop-down to deploy generated config to the Leaf switches

**Step 2:** Apply the QoS policy on the Peer-link of Leaf switches (connecting to Azure Local).

This is required to apply QoS on any traffic which may pass over the peer-link.

From Fabric **Overview > Interfaces** tab, select the peer-link port-channel interfaces for Leaf-1 and Leaf-2 and click on **Edit** from **Actions** drop-down.

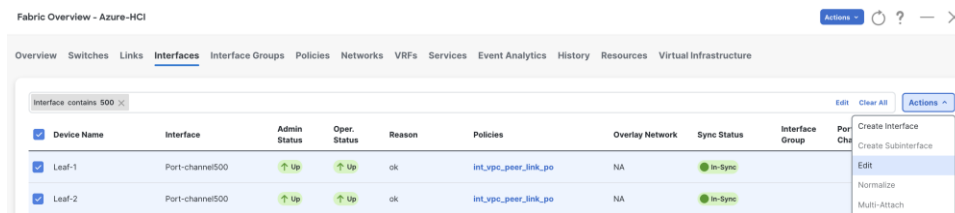

1 of 2 Selected Interface(s) :

Interface  
Leaf-1 : Port-channel500

Policy\*  
int\_vpc\_peer\_link\_po >

Policy Options

VPC Peer-Link Port-Channel Member Interfaces  
Ethernet1/39,Ethernet1/40 A list of member interfaces (e.g. e1/5,eth0/7-9)

VPC Peer-link Trunk Allowed Vlans  
Select an Option VPC Peer-link Allowed Vlan list (empty=all or none)

Native Vlan  
VLAN ID to set as the interface native vlan

Port Channel Description  
Add description to the port-channel (Max Size 254)

Members Description  
Add description, if members don't have any (same for all members, Max Size 254)

Port Channel Admin State\*  
 Admin state of the port-channel

Freeform Config

```
service-policy type qos input AzS_HCI_QoS
```

Additional CLI for the interface

Click on **Save** button for Leaf-1.

Click on **Next** button and repeat the same step for vPC peer-link of Leaf-2.

Verify the pending configuration and deploy.

```
Pending config
Azure-HCI > Leaf-1 > Port-channel500
1 interface port-channel500
2 switchport
3 switchport mode trunk
4 spanning-tree port type network
5 description "vpc-peer-link Leaf-1--Leaf-2"
6 no shutdown
7 service-policy type qos input AzS_HCI_QoS
8 configure terminal
9
```

```
Pending config
Azure-HCI > Leaf-2 > Port-channel500
1 interface port-channel500
2 switchport
3 switchport mode trunk
4 spanning-tree port type network
5 description "vpc-peer-link Leaf-2--Leaf-1"
6 no shutdown
7 service-policy type qos input AzS_HCI_QoS
8 configure terminal
9
```

**Step 3:** Apply the QoS policy on Leaf switch interfaces which are used to connect to Azure Local.

Cisco NDFC allows grouping the interfaces using Interface Groups. All the interfaces which require identical configuration can be grouped together using an Interface Group and all the required configuration is applied only to the Interface Group.

Although Leaf-1 and Leaf-2 interfaces connecting to Azure Local server require same QoS configuration, they would be carrying different VLANs for RDMA traffic (Leaf-1 for Storage-A and Leaf-2 for Storage-B) therefore two separate Interface Groups are required.

Fabric Overview - Azure-HCI

Overview Switches Links **Interfaces** Interface Groups Policies Networks VRFs Services Event Analytics History Resources Virtual Infrastructure

Description contains A23

Device Name	Interface	Admin Status	Oper. Status	Reason	Policies	Overlay Network	Sync Status	Interface Group	Port Channel ID
<input checked="" type="checkbox"/> Leaf-1	Ethernet1/11	<span style="color: green;">↑ Up</span>	<span style="color: red;">↓ Down</span>	XCVR not inserted	int_trunk_host	NA	<span style="color: green;">● In-Sync</span>		
<input checked="" type="checkbox"/> Leaf-1	Ethernet1/12	<span style="color: green;">↑ Up</span>	<span style="color: red;">↓ Down</span>	XCVR not inserted	int_trunk_host	NA	<span style="color: green;">● In-Sync</span>		
<input type="checkbox"/> Leaf-2	Ethernet1/11	<span style="color: green;">↑ Up</span>	<span style="color: red;">↓ Down</span>	XCVR not inserted	int_trunk_host	NA	<span style="color: green;">● In-Sync</span>		
<input type="checkbox"/> Leaf-2	Ethernet1/12	<span style="color: green;">↑ Up</span>	<span style="color: red;">↓ Down</span>	XCVR not inserted	int_trunk_host	NA	<span style="color: green;">● In-Sync</span>		

Actions: Add to Interface Group, Remove from Interface Group

Ports Eth1/11-12 are added to **Leaf-1\_Azure\_HCI\_Server\_ports** Interface Group with following settings:

- Set Interface Type: Ethernet
- Policy: int\_ethernet\_trunk\_host
- Enable BPDU Guard: True
- Enable Port Type Fast: Yes
- MTU: Jumbo (9216 bytes)
- Native VLAN: Can be set to Mgmt Vlan (Optional)
- Freeform Config: Provide service-policy CLI command to apply QoS and Queuing policies and CLI command to enable Policy Flow Control to the interfaces

Create Interface Group

Fabric Name\*  
Azure-HCI

Interface Group Name\*  
Leaf-1\_Azure\_HCI\_Server\_ports

Interface Type\*  
 Ethernet  Port-Channel  vPC  ANY

Policy  
int\_shared\_trunk\_host >

Policy Options

Enable BPDU Guard\*  
true Enable spanning-tree bpduguard: true=enable, false=disable, not=return to default settings

IG for Fax Ports\*  
 Shared group for fax ports

Enable Port Type Fast\*  
 Enable spanning-tree edge port behavior

MTU\*  
jumbo MTU for the interface

SPEED\*  
Auto Interface Speed

AUTO NEGOTIATE\*  
on Auto Negotiate mode for speed

Trunk Allowed Vlans\*  
none Allowed values: 'none', 'all', or vlan ranges (ex: 1-200,600-2000,3000)

Native Vlan  
  
Set native VLAN for the interface

Enable vPC Orphan Port  
 If enabled, configures the interface as a vPC orphan port to be suspended by the secondary peer in vPC failures

Freeform Config  
priority-flow-control mode on  
service-policy type qos input AZS\_HCI\_QoS  
service-policy type queuing output QOS\_EGRESS\_PORT

Repeat the above steps for adding Leaf-2 ports Eth1/11-12 to **Leaf-2\_Azure\_HCI\_Server\_ports** Interface Group -

Device Name	Interface	Admin Status	Oper. Status	Reason	Policies	Overlay Network	Sync Status	Interface Group	Port Channel ID	vPC id	Speed	MTU	Mode
Leaf-1	Ethernet1/11	Up	Down	XCVR not inserted	int_shared_trunk_host	NA	In-Sync	Leaf-1_Azure_HCI_Server_ports			25Gb	9216	trunk
Leaf-1	Ethernet1/12	Up	Down	XCVR not inserted	int_shared_trunk_host	NA	In-Sync	Leaf-1_Azure_HCI_Server_ports			25Gb	9216	trunk
Leaf-2	Ethernet1/11	Up	Down	XCVR not inserted	int_shared_trunk_host	NA	In-Sync	Leaf-2_Azure_HCI_Server_ports			25Gb	9216	trunk
Leaf-2	Ethernet1/12	Up	Down	XCVR not inserted	int_shared_trunk_host	NA	In-Sync	Leaf-2_Azure_HCI_Server_ports			25Gb	9216	trunk

Now we have enabled PFC and applied QoS and Queuing policies on Leaf-1 & Leaf-2 respective interfaces. We'll now create the networks (Vlans) required for Azure Local in next section.

### Configure LLDP

Cisco NDFC enables the LLDP feature on all the devices in the VXLAN fabric and LLDP is enabled on all the interfaces on all devices. However, LLDP is not enabled by Cisco NDFC for traditional classic LAN fabrics. For traditional classic LAN fabrics, the `_lldp` policy feature must be associated to the Leaf switches for LLDP support.

### Configure Networks for Azure Local

Following are the network requirements for Azure Local:

- Two Layer-3 networks with Anycast Gateway configured on the leafs
- Two Layer-2 networks for Storage (one for each leaf)

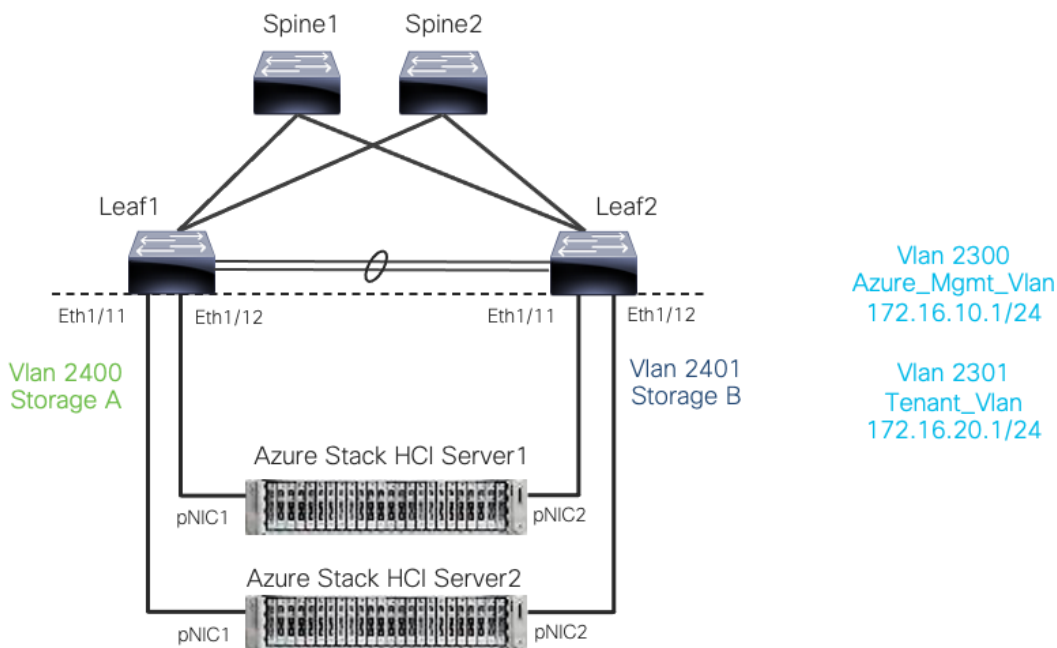

**Figure 23.** Cisco NX-OS based networks for Azure Local

On VXLAN fabric all the Layer-3 networks need to be mapped to a VRF which provides isolation between any two tenants. All the networks pertaining to a tenant are mapped to the respective tenant VRF. Layer-2 networks do not need to be mapped to VRF.

To create VRF, go to **Fabric Detailed View > VRF > Actions** and choose **Create VRF** and provide following parameters:

- VRF Name: Azure\_Tenant\_VRF\_50000
- VRF ID: provide VNI for VRF
- VLAN ID: provide Vlan for VRF
- VRF VLAN Name: provide name for the VLAN (optional)

**Create VRF**

VRF Name\*  
Azure\_Tenant\_VRF\_50000

VRF ID\*  
50000

VLAN ID  
2000 [Propose VLAN](#)

VRF Template\*  
[Default\\_VRF\\_Universal >](#)

VRF Extension Template\*  
[Default\\_VRF\\_Extension\\_Universal >](#)

**General Parameters** **Advanced** **Route Target**

VRF VLAN Name  
Azure\_Tenant\_VRF\_Vlan If > 32 chars, enable 'system vlan long-name' for NX-OS

VRF Interface Description

VRF Description

Once the VRF is created, Networks can be created. To create Networks, go to **Fabric Detailed View >> Network >> Actions** and choose **Create Network**.

Let's create Layer-3 network used for management of Azure Local recourses with following parameters:

- Network Name - Azure\_Mgmt\_Network\_30000
- VRF Name - provide Azure\_Tenant\_VRF\_50000

- Network ID - 30000
- VLAN ID - 2300
- IPv4 Gateway/Netmask - 172.16.10.1/24
- VLAN Name - Azure\_Mgmt\_Vlan
- MTU for L3 Interface - 9216 bytes

### Create Network

Network Name\*

Layer 2 Only

VRF Name\*  
 ✕ ▼ Create VRF

Network ID\*

VLAN ID  
 ▼ Propose VLAN

Network Template\*  
[Default\\_Network\\_Universal >](#)

Network Extension Template\*  
[Default\\_Network\\_Extension\\_Universal >](#)

Generate Multicast IP Please click only to generate a New Multicast Group address and override the default value!

---

**General Parameters** Advanced

IPv4 Gateway/NetMask  
 example 192.0.2.1/24

IPv6 Gateway/Prefix List  
 example 2001:db8:1::/64,2001:db8:1::/64

VLAN Name  
 If > 32 chars, enable 'system vlan long-name' for NX-OS, disable VTPv1 and VTPv2 or switch to VTPv3 for

Interface Description

MTU for L3 interface  
 66-9216, NX-OS Specific

Let's create second Layer-3 network used for Azure Local Tenants:

- Network Name: Tenant\_Network\_30001
- VRF Name: Azure\_Tenant\_VRF\_50000
- Network ID: 30001
- VLAN ID: 2301
- IPv4 Gateway/Netmask: 172.16.20.1/24
- VLAN Name: Tenant\_Network\_Vlan
- MTU for L3 Interface: 9216 bytes

**Create Network**

Network Name\*

Layer 2 Only

VRF Name\*  
 ✕ ▼ Create VRF

Network ID\*

VLAN ID  
 Propose VLAN

Network Template\*  
[Default\\_Network\\_Universal >](#)

Network Extension Template\*  
[Default\\_Network\\_Extension\\_Universal >](#)

Generate Multicast IP Please click only to generate a New Multicast Group address and override the default value!

**General Parameters** Advanced

IPv4 Gateway/NetMask  
 example 192.0.2.1/24

IPv6 Gateway/Prefix List  
 example 2001:db8::1/64,2001:db9::1/64

VLAN Name  
 If > 32 chars, enable 'system vlan long-name' for NX-OS, disable VTPv1 and VTPv2 or switch to VTPv3 for IOS XE

Interface Description

MTU for L3 interface  
 68-9216, NX-OS Specific

Now, we will create Layer-2 networks for Storage. Unlike the L3 networks, L2 networks don't have any SVI and does not require mapping to VRF. To create L2 network, check **Layer 2 Only** check box.

Create L2 network for Storage-A with the following parameters:

- Network Name: Storage-A\_30100
- Network ID: 30100
- VLAN ID: 2400
- VLAN Name: Storage-A\_Vlan

### Create Network

Network Name\*  
Storage-A\_Network\_30100

Layer 2 Only

VRF Name\*  
NA Create VRF

Network ID\*  
30100

VLAN ID  
2400 Propose VLAN

Network Template\*  
[Default\\_Network\\_Universal](#) >

Network Extension Template\*  
[Default\\_Network\\_Extension\\_Universal](#) >

Generate Multicast IP Please click only to generate a New Multicast Group address and override the default value!

---

**General Parameters** Advanced

IPv4 Gateway/NetMask  example 192.0.2.1/24

IPv6 Gateway/Prefix List  example 2001:db8::1/64,2001:db8::1/64

VLAN Name  
 If > 32 chars, enable 'system vlan long-name' for NX-OS, disable VTPv1 and VTPv2 or switch to VTPv3 for

Interface Description

MTU for L3 interface  68-9216, NX-OS Specific

Create L2 network for Storage-B with the following parameters:

- Network Name - Storage-B\_30101
- Network ID - 30101
- VLAN ID - 2401
- VLAN Name - Storage-B\_Vlan



### Create Network

Network Name\*  
Storage-B\_Network\_30101

Layer 2 Only

VRF Name\*  
NA Create VRF

Network ID\*  
30101

VLAN ID  
2401 Propose VLAN

Network Template\*  
[Default\\_Network\\_Universal](#)

Network Extension Template\*  
[Default\\_Network\\_Extension\\_Universal](#)

Generate Multicast IP Please click only to generate a New Multicast Group address and override the default value!

---

**General Parameters** **Advanced**

IPv4 Gateway/NetMask  example 192.0.2.1/24

IPv6 Gateway/Prefix List  example 2001:db8::1/64,2001:db9::1/64

VLAN Name  
 If > 32 chars, enable 'system vlan long-name' for NX-OS, disable VTP-v1 and VTP-v2 or switch to VTP-v3 for

Interface Description

MTU for L3 interface  68-9216, NX-OS Specific

We can verify all the networks from Networks tab of the fabric -

Fabric Overview - Azure-HCI

Overview Switches Links Interfaces Interface Groups Policies **Networks** VRFs Services Event Analytics History Resources Virtual Infrastructure

Filter by attributes

<input type="checkbox"/>	Network Name	Network ID	VRF Name	IPv4 Gateway/Prefix	IPv6 Gateway/Prefix	Network Status	VLAN ID
<input type="checkbox"/>	Azure_Mgmt_Network_30000	30000	Azure_Tenant_VRF_50000	172.16.10.1/24		NA	2300
<input type="checkbox"/>	Tenant_Network_30001	30001	Azure_Tenant_VRF_50000	172.16.20.1/24		NA	2301
<input type="checkbox"/>	Storage-A_Network_30100	30100	NA			NA	2400
<input type="checkbox"/>	Storage-B_Network_30101	30101	NA			NA	2401

Next, we attach the networks to the interfaces, select the networks to be attached and click **Actions >> Attach to Interface Group**. We have attached Azure\_Mgmt and Tenant networks to both the Leafs however Storage networks are attached to the respective switches.

Fabric Overview - Azure-HCI

Overview Switches Links Interfaces Interface Groups Policies **Networks** VRFs Services Event Analytics History Resources Virtual Infrastructure

Filter by attributes Actions

<input type="checkbox"/>	Network Name	Network ID	VRF Name	IPv4 Gateway/Prefix	IPv6 Gateway/Prefix	Network Status	VLAN ID	Interface Group
<input type="checkbox"/>	Azure_Mgmt_Network_30000	30000	Azure_Tenant_VRF_50000	172.16.10.1/24		OK (UP)	2300	Leaf-1_Azure_HCI_Server_ports; Leaf-2_Azure_HCI_Server_ports
<input type="checkbox"/>	Tenant_Network_30001	30001	Azure_Tenant_VRF_50000	172.16.20.1/24		OK (UP)	2301	Leaf-1_Azure_HCI_Server_ports; Leaf-2_Azure_HCI_Server_ports
<input type="checkbox"/>	Storage-A_Network_30100	30100	NA			OK (UP)	2400	Leaf-1_Azure_HCI_Server_ports
<input type="checkbox"/>	Storage-B_Network_30101	30101	NA			OK (UP)	2401	Leaf-2_Azure_HCI_Server_ports

Once all the networks are attached, select the networks and click on **Actions > Deploy** for NDFC to generate and push the config to the devices.

### Build External Connectivity for Azure Local servers

Any network outside of VXLAN fabric is referred as external, to provide connectivity to such networks VRF\_Lite (MPLS Option A) is used. Cisco NDFC supports full automation for extending connectivity to external networks from a VXLAN or Traditional Classical LAN fabric.

VXLAN devices which perform IPv4/IPv6 handoff are referred as Border devices this role is also supported in Cisco NDFC. Once the Tenant VRF is deployed on the border devices it can be further extended towards external networks.

Following NDFC settings are required under **Resources** tab of the fabric template for setting up external connectivity for VXLAN fabric.

VRF Lite Deployment\*  
 Back2Back&ToExternal

VRF Lite Inter-Fabric Connection Deployment Options. If 'Back2Back&ToExternal' is selected, VRF Lite IFCs are auto created between border devices of two Easy Fabrics, and between border devices in Easy Fabric and edge routers in External Fabric. The IP address is taken from the 'VRF Lite Subnet IP Range' pool.

Auto Deploy for Peer   
 Whether to auto generate VRF LITE sub-interface and BGP peering configuration on managed neighbor devices. If set, auto created VRF Lite IFC links will have 'Auto Deploy for Peer' enabled.

Auto Deploy Default VRF   
 Whether to auto generate Default VRF interface and BGP peering configuration on VRF LITE IFC auto deployment. If set, auto created VRF Lite IFC links will have 'Auto Deploy Default VRF' enabled.

Auto Deploy Default VRF for Peer   
 Whether to auto generate Default VRF interface and BGP peering configuration on managed neighbor devices. If set, auto created VRF Lite IFC links will have 'Auto Deploy Default VRF for Peer' enabled.

Redistribute BGP Route-map Name  
 Route Map used to redistribute BGP routes to IGP in default vrf in auto created VRF Lite IFC links

VRF Lite Subnet IP Range\*  
 10.33.0.0/16  
 Address range to assign P2P Interfabric Connections

VRF Lite Subnet Mask\*  
 30 (Min:8, Max:31)

Change VRF Lite IP Subnet range and subnet mask (if required), if required.

Before you start make sure, border devices have the VRF deployed. If not, attach the VRF to the border devices.

To configure the VRF\_Lite extension, select the required VRF and go to the VRF detailed view from VXLAN fabric. Under **VRF Attachments** tab, select the border devices and click on **Edit** from **Actions** drop-down -

VRF Name	VRF ID	VLAN ID	Switch	Status	Attachment	Switch Role	Fabric Name	Loopback ID	Loopback IPv4 Address	Loopbo	History
Azure_Tenant_VRF_50000		2000	Leaf-2	OK (1/1)	Attached	leaf	Azure-HC				Edit
Azure_Tenant_VRF_50000		2000	Leaf-1	OK (1/1)	Attached	leaf	Azure-HC				Preview
Azure_Tenant_VRF_50000		2000	Leaf-5	OK (1/1)	Attached	border	Azure-HC				Deploy
Azure_Tenant_VRF_50000		2000	Leaf-6	OK (1/1)	Attached	border	Azure-HC				Import
											Export
											Quick Attach
											Quick Detach

For each border device select **VRF\_LITE** from drop-down under **Extend** and click on **Attach-All** button. Additional parameters can be provided by clicking on **Exit** link under **Action**.

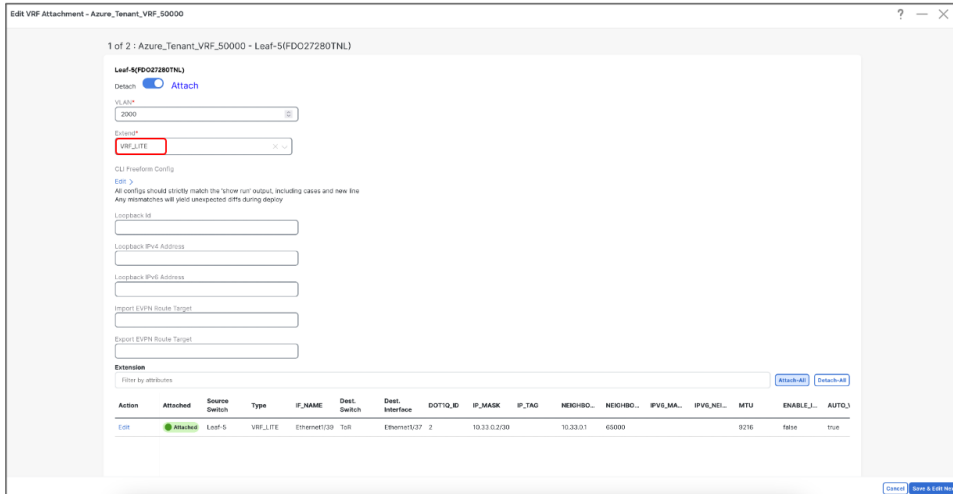

Repeat the same steps and any additional border devices and click on **Save**.

Now we are back to VRF Attachment tab, to deploy the configuration to devices click on **Deploy** from **Actions** (at top) drop-down.



Cisco NDFC will push the required configuration to the border devices in the VXLAN fabrics.

If the external network is also managed by NDFC, perform **Recalculate and Deploy** in External fabric too for Cisco NDFC to push configuration to the device which is being used as other end for VRF\_Lite extension.

This allows VXLAN networks to be advertised to external and vice-versa for any outside communication to take place.

## Appendix

### Design Example with Microsoft Software Defined Networking (SDN) in Azure Local

In addition to VLAN based tenant network, Azure Local has a network design option with Microsoft SDN, which includes VXLAN termination in the server side. This section provides design examples of Cisco ACI and Nexus 9000 for Microsoft SDN in Azure Local. This section does not cover the configuration required on Azure Local side. The physical architecture of the Microsoft Azure Local connectivity to Cisco Nexus Switches remains the same as the one explained in [Physical Architecture](#) section.

### Microsoft Azure SDN Components

Microsoft Azure SDN introduces additional features, such as Software Load Balancer, Firewalls, Site-to-Site IPsec-VPN, and Site-to-Site GRE tunnels. The Software Load Balancer and Firewalls provide load balancing and firewalling services for the virtual machines hosted in the Azure Local cluster. Site-to-Site IPsec VPN and Site-to-Site GRE tunnels enable connectivity between virtual machines hosted in Azure Local cluster and external networks outside the Azure Local.

The following VMs are the major components of Microsoft Azure SDN in Azure Local:

- Network Controller VMs: Network Controller VMs provide a centralized point to create and manage virtual network infrastructure inside the Azure Local. Network Controller VMs act as the control plane for the Azure Local SDN and do not carry actual data traffic. Microsoft recommends a minimum of three Network Controller VMs for redundancy.
- Software Load Balancer VMs: Software Load Balancer (SLB) VMs provide Layer 4 load balancing services for north-south and east-west TCP/UDP traffic. The Software Load Balancer VMs are installed on the Azure Local servers to provide load balancing services in the Azure Local Cluster. Microsoft uses the terminology Software Load Balancer Multiplexer VMs or SLB MUX VMs instead of SLB VMs. Henceforth, this document will use SLB MUX VMs to describe the Software Load Balancer VMs. A minimum of one SLB MUX VM is required per Azure Local Cluster, and the count can be increased based on the scale. More on the Software Load Balancer will be discussed later in this document.
- Gateway VMs: Gateway VMs create layer 3 connections between Microsoft Azure SDN virtual networks (VNETs) inside the Azure Local and external networks outside the Azure Local. Features such as IPsec VPNs and GRE tunnels are handled by the Gateway VMs. Microsoft recommends a minimum of two Gateway VMs per Azure Local Cluster and the count can be increased based on the scale.

**Note:** Please contact Microsoft for official scalability guidelines for the deployment of Network Controller VMs, SLB MUX VMs, and Gateway VMs.

## Logical Architecture

Apart from the [Management Network](#) and [Storage Network](#) described earlier in this document, the following networks are to be used in Microsoft Azure SDN within Azure Local:

- HNV PA Network (Hyper-V Network Virtualization Provider Address Network)
- Logical Network

### HNV PA Network

The Hyper-V Network Virtualization (HNV) Provider Address (PA) network is deployed when multi-tenancy is required in Microsoft Azure SDN within the Azure Local. The PA Network uses VXLAN encapsulation to achieve multi-tenancy. The PA network Address is similar to VTEP IP address in Nexus Switches. It serves as the underlay physical network for east-west VM-to-VM communication within an Azure Local cluster. The PA network requires a VLAN to be assigned on the physical network, which is passed as trunk on the data interfaces of all the servers in the cluster.

Each server in an Azure Local cluster has two PA network IP addresses, while each SLB MUX VM and Gateway VM has one IP address from the PA network. Thus, for a 16-node cluster, a /26 or larger subnet may be required because multiple SLB MUX VMs and Gateway VMs are required based on the scale.

### Logical Network

A Logical Network is a network segment between the Azure Local servers and top-of-rack switches such as Cisco ACI leaf switches. Each Logical Network consists of a Logical subnet that requires a VLAN ID and an address prefix. The VLAN ID needs to be unique in the Azure Local cluster. The address prefix requires at least four IP addresses: one for the Azure Local cluster, one for each VLAN interface of each top-of-rack switch, and one for the virtual IP address that is shared by the pair of top-of-rack switches. The Logical Network acts as a physical path to carry traffic between the Azure Local VNET and the top-of-rack

switches. VNET is a virtual network in Azure Local and is equivalent to VRF in Cisco ACI and Nexus 9000 in NX-OS mode.

## PA Network and SLB MUX VMs Connectivity

This section describes how to connect the PA network and SLB MUX VMs to a Cisco ACI and Cisco NX-OS based fabric.

### Software Load Balancer (SLB)

An important consideration before designing the PA network connectivity in a Cisco ACI and Cisco NX-OS-based fabric is to understand the Software Load Balancer functionality and its connectivity requirements because SLB MUX VMs are mandatory in the Microsoft Azure SDN installation. SLB MUX VMs can be used for public access to a pool of load balanced VMs inside the VNET in Azure Local as well as load balancing network traffic within the VNETs.

This document uses an example with three SLB MUX VMs deployed in an Azure Local cluster. Each SLB MUX VM has one unique IP address from the PA network. An SLB MUX VM can be hosted on any of the Azure Local servers that are part of the Azure Local Cluster.

SLB MUX VMs need to have eBGP peering configured with the IPs of external routers (Cisco ACI Leaf switches in this case) for external network reachability.

Two additional IP Pools (Public VIP Pool and Private VIP pool) are required for the SLB MUX VMs deployment. The Public VIP Pool and Private VIP Pool are allocated to the SLB MUX VMs for assigning Virtual IPs. These Virtual IPs are used by applications or services that are hosted inside the Azure Local cluster that require the load balancing feature. These IP Pools are provisioned on top of the SLB MUX VMs.

**Note:** The SLB MUX VMs do not use an IP address to be assigned to themselves from these IP pools. SLB MUX VMs use IP addresses assigned from the PA network.

- **Public VIP Pool:** It must use IP subnet prefixes that are routable outside the Azure Local cluster (not necessarily an Internet Routable Public IP). These are front-end IP addresses that external clients use to access VMs in the VNETs, including front-end VIP for Site-to-Site VPN. The Public VIP is used to reach a load balanced application or a service from outside of the Azure Local cluster.
- **Private VIP Pool:** This IP subnet prefix is not required to be routable outside of the Azure Local cluster. These VIPs are meant to be accessed by internal client's that are part of the VNET in the Azure Local Cluster. The Private VIP is used if the load-balanced application or service does not require reachability from outside the Azure Local cluster.

### Cisco ACI Design for PA Network and SLB Connectivity

SLB MUX VMs are part of PA network and need to have eBGP peerings with the leaf switches for communication with other networks. Therefore, L3Out needs to be configured with an encap VLAN that is same as the PA network VLAN ID configured inside the Azure Local.

The figure below illustrates a logical design example of eBGP peering of SLB MUX with Cisco ACI leaf switches.

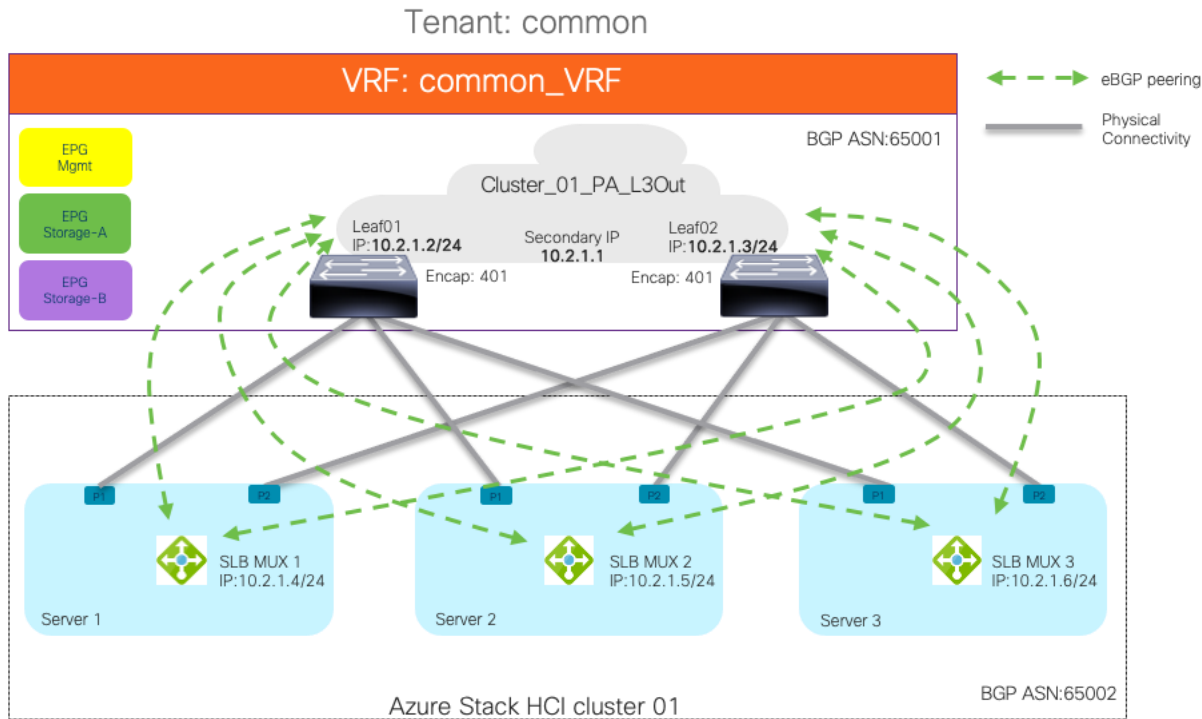

**Figure 24.**  
eBGP peering of SLB MUX & ACI in PA Network

The figure above also illustrates an example of a high-level relationship between Cisco ACI tenant elements as deployed in the design for the Azure Local underlay connectivity. In this example, Cisco ACI common tenant contains a VRF called Common\_VRF EPGs for storage and management networks.

This tenant also contains an L3Out named Cluster\_01\_PA\_L3Out that is dedicated for the PA network connectivity for the specific cluster. eBGP will be the routing protocol configured in the L3Out, while the encap vlan used in the L3Out will be the same VLAN configured as the PA network VLAN in the Azure Local Cluster.

As this example has three SLB MUX VMs deployed per cluster, each Cisco ACI leaf will have three eBGP peers. Therefore, a total of six The eBGP peerings are established between the Azure Local cluster and the pair of Cisco ACI leaf switches. In this example, 10.2.1.0/24 is the IP subnet, and 401 is the VLAN ID assigned to the PA network. The SVI interface configured on Cisco ACI leaf switch will be 10.2.1.2/24 and 10.2.1.3/24 for Leaf 01 and Leaf 02 respectively. The three SLB MUX VMs will have IP addresses as 10.2.1.4/24, 10.2.1.5/24, and 10.2.1.6/24 respectively. The eBGP peering with a loopback IP address or an IP address that is not directly connected is NOT supported. Therefore, eBGP peering is formed with an L3Out SVI interface of the Cisco ACI leaf switches.

**Note:** Each Azure Local Cluster requires one dedicated EPG for storage, one dedicated EPG for management, and one dedicated L3Out and its external EPG for the PA network.

### Azure Local VNET Connectivity (Logical Network and Gateway VMs connectivity)

VNET is a virtual network in the Azure Local. It is created with an address prefix. Multiple smaller subnets can be created from the VNET address prefix for the purpose of IP assignment to workload VMs.

One of the subnets is used as a gateway subnet. The gateway subnet is required to communicate outside the Azure Local VNET. An IP address from this subnet is automatically provisioned on the gateway VM. This subnet can be configured with a /28, /29, or /30 prefix. The /28 or /29 subnet prefix is required if an IPsec or GRE tunnel is needed in the gateway subnet because additional IP addresses from the subnet are provisioned on the gateway VMs whenever an IPsec or GRE tunnel is required. This document doesn't cover IPsec or GRE tunnel.

### Cisco ACI Design for Azure Local VNET Connectivity

The gateway VM establishes two eBGP peerings with the loopback IP address configured on the pair of ACI leaf switches. A static route is required in the Azure Local VNET for reachability to the loopback IP address. The next hop IP address for the static route is the virtual IP address configured on the pair of Cisco ACI leaf switches from the Logical Network.

**Note:** The next hop IP address for static route used for eBGP peering is called the L3 Peer IP in Azure Local and the virtual IP address configured on VLAN interface in Azure Local is called the secondary IPv4 address in Cisco ACI.

An L3Out is configured on the Cisco ACI fabric for the connection towards the VNET in Azure Local Cluster. The Cisco ACI leaf switches establish two eBGP peerings (one from each ACI leaf switch) with the IP address assigned to the gateway VM. This IP address can be found in the BGP router IP address under the Gateway connections section in Azure Local. A static route is configured on the Cisco ACI leaf switches for reachability to the gateway VM IP address. The next hop for this static route is the IP address from the Logical Network configured on the Azure Local Cluster.

The figure below shows an example of the Cisco ACI L3Out with the Azure Local VNET connectivity.

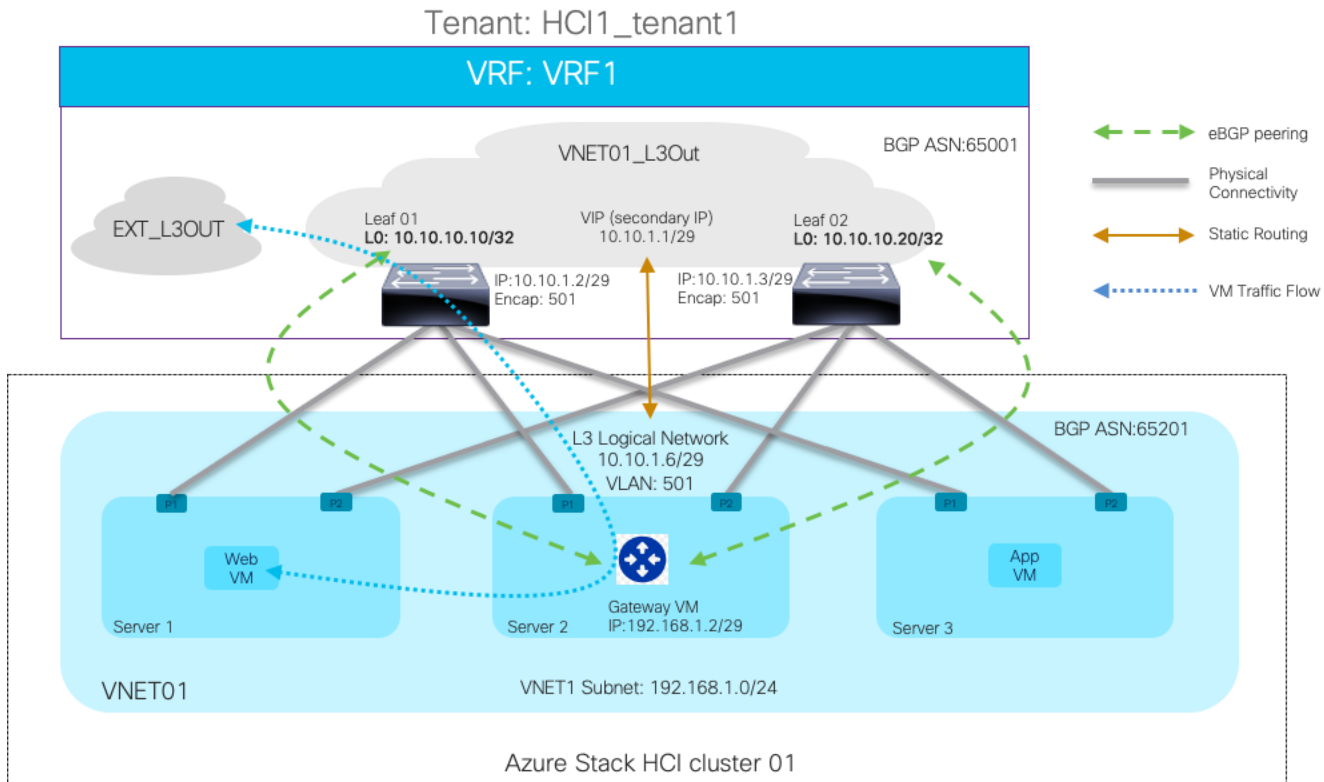

**Figure 25.** EBGP peering of Azure Gateway VM with Cisco ACI Leaf switches



The design example has a 3-node Azure Local Cluster connected to a pair of ACI leaf switches, which contains the following network configurations in Azure Local:

- A VNET named VNET01 is created in Azure Local with an address prefix 192.168.1.0/24. The gateway subnet is 192.168.1.0/29.
- A Logical Network in the Azure Local uses the IP subnet 10.10.1.0/29 and VLAN ID 501. 10.10.1.6/29 is used for the gateway connection towards the Cisco ACI leaf switch. In this example, eBGP Multihop is used, and 65201 is the BGP ASN of the Gateway VM.
- Static routes (10.10.10.10/32 and 10.10.10.20/32 via 10.10.1.1) are configured to reach the loopback IP addresses of the pair of ACI leaf switches. The IP address 10.10.1.1 is configured as the virtual IP address (Secondary IPv4 address) on the VLAN interface of both ACI leaf switches.
- The Web and App VM that are also part of the VNET01 will always send traffic to the gateway VM if the destination IP address is outside the VNET\_01.

To establish the connection with Azure Local, the Cisco ACI fabric contains the following configurations:

- An ACI tenant named HCI1\_tenant1 and a VRF named VRF1 are created, which correspond to the VNET\_01 in Azure Local.
- An L3Out named VNET01\_L3Out is created for eBGP peering with the gateway VMs in VNET01.
  - Leaf01 has the loopback IP 10.10.10.10/32 and Leaf02 has the loopback IP 10.10.10.20/32.
  - The Logical Interface profile inside the L3Out is configured with VLAN interfaces. The VLAN interfaces are assigned IP addresses from the subnet 10.10.1.0/29, and the encap VLAN ID is 501 (which is same as the one defined in the Azure Local Logical Network).
  - A static route (192.168.1.0/29) is configured to reach the gateway VM (192.168.1.2) under the Logical Node profile inside the L3Out, and the next hop is 10.10.1.6.
  - eBGP multihop with a value two or greater is required to build the eBGP peering.
- Another L3Out named EXT\_L3Out is used for communication outside the Cisco ACI fabric.

## Solution Deployment

This section provides a detailed procedure to configure Cisco ACI and Azure Local with SDN enabled. It is assumed that the ACI fabric and APICs already exist in the customer's environment. This document does not cover the configuration required to bring the initial ACI fabric online.

[Table 3](#) lists the hardware and software versions used in this solution.

The figure below and Table 9 summarize the topology, interface, and L3 domain configuration parameters used in this section. The connection uses six 100 GbE interfaces between ACI leaf switches and Azure Local servers.



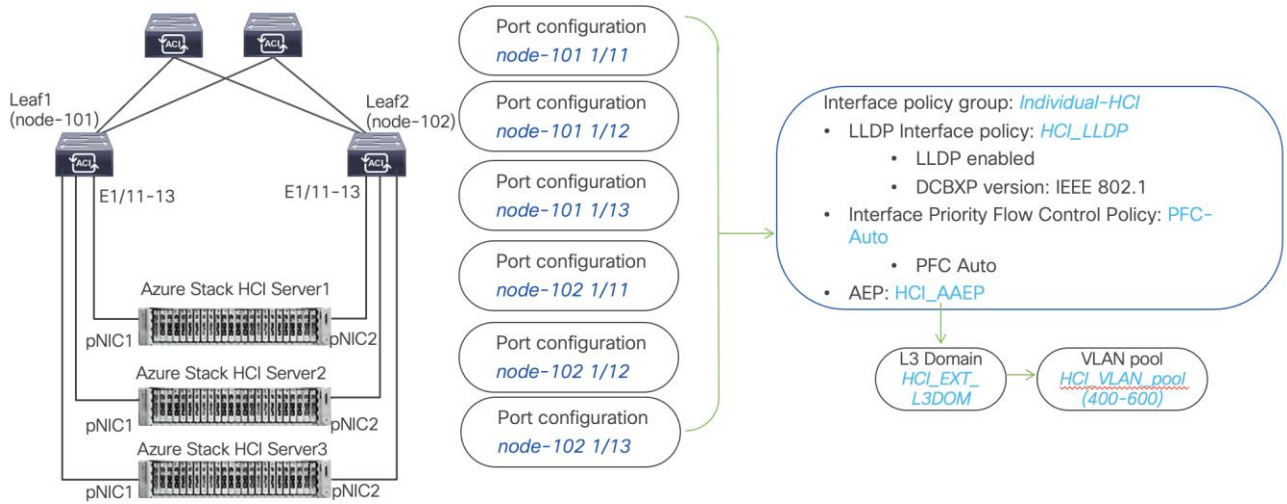

**Figure 26.**  
Interface and L3 domain configuration for Azure Local servers with SDN

**Table 9.** Interface and L3 Domain configuration for Azure Local Servers

Interface	Interface Policy Group	LLDP Interface Policy	Interface PFC Policy	AAEP Name	Domain Name	Domain type	VLAN Pool
<b>Leaf1 and Leaf2 Ethernet 1/11-13</b>	Individual-HCI	HCI_LLDP (DCBXP: IEEE 802.1)	PFC-Auto	HCI_AAEP	HCI_EXT_L3DOM	L3	HCI_VLAN_pool (VLAN 400-600)

**Interface and L3 Domain configuration for Azure Local Servers**

Tables 10 and 11 summarize the ACI common and the user tenant configuration parameters used in this section. The ACI leaf switches serve as the gateway to the Azure Local networks except for storage networks that are L2 only. Although contract names are listed for your reference, the shared L3Out configuration in the common tenant and contract configuration steps are not covered in this document.

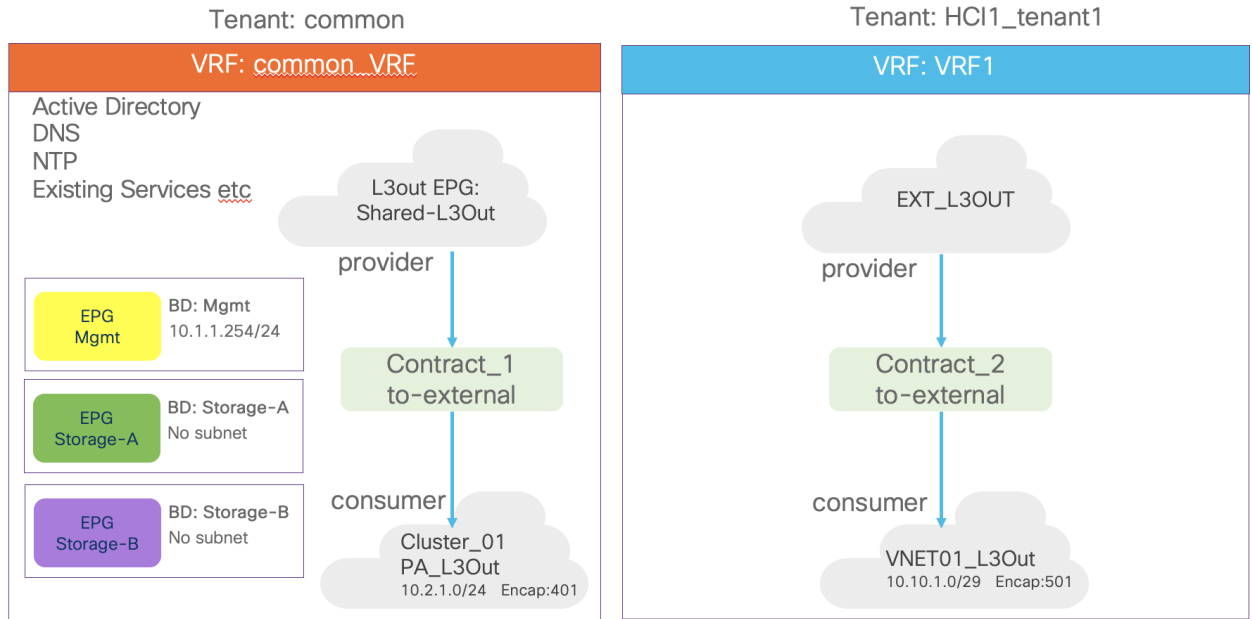

**Figure 27.**  
ACI Tenant Overview for Azure Local with Microsoft SDN

**Table 10. ACI common tenant configuration example for SLB MUX connectivity**

Property	Name
Tenant	Common
Tenant VRF	common_VRF
Bridge domains	Storage-A in common_VRF (No subnet) Storage-B in common_VRF (No subnet) Mgmt in common_VRF (10.1.1.254/24)
Leaf nodes and interfaces	Node 101 & 102 ethernet1/11, 1/12 and 1/13
EPGs	EPG Mgmt in BD Mgmt EPG Storage-A in BD Storage-A EPG Storage-B in BD Storage-B
Contract	Contract_1_to-external
L3Out	Cluster_01_PA_L3Out (BGP) in common tenant
Logical Node Profiles	Cluster_01_PA_101_NP (Node-101) - Router ID: 1.1.1.1 Cluster_01_PA_102_NP (Node-102) Router ID: 2.2.2.2
Logical Interface Profile	Cluster_01_PA_101_IFP (eth1/11, eth1/12 and eth1/13) - Interface Type: SVI - Primary IP: 10.2.1.2/24 - Secondary IP: 10.2.1.1/24 - Encap: 401

Property	Name
	<ul style="list-style-type: none"> <li>- BGP Peer: 10.2.1.4, 10.2.1.5, 10.2.1.6</li> <li>- Remote AS: 65002</li> </ul> Cluster_01_PA_102_IFP (eth1/11, eth1/12 and eth1/13) <ul style="list-style-type: none"> <li>- Interface Type: SVI</li> <li>- Primary IP: 10.2.1.3/24</li> <li>- Secondary IP: 10.2.1.1/24</li> <li>- Encap: 401</li> <li>- BGP Peer: 10.2.1.4, 10.2.1.5, 10.2.1.6</li> </ul> Remote AS: 65002
External EPGs	Cluster_01_PA_EXT_EPG Export Route Control Subnet (0.0.0.0)

**Table 11. ACI user tenant configuration example for Gateway VM connectivity**

Property	Name
Tenant	HCI1_tenant1
Tenant VRF	VRF1
Leaf nodes and interfaces	Node 101 & 102 ethernet1/11, 1/12 and 1/13
Contract	Contract_2_to-external
L3Out	VNET01_L3Out (BGP) in HCI1_tenant1
Logical Node Profiles	VNET01_101_NP (Node-101) <ul style="list-style-type: none"> <li>- Loopback IP: 10.10.10.10</li> <li>- Router ID: 1.1.1.1</li> <li>- Static route: 192.168.1.0/29, Next Hop: 10.10.1.6</li> <li>- BGP Peer: 192.168.1.2, Source Interface: loopback</li> <li>- Remote AS: 65201</li> </ul> VNET02_102_NP (Node-102) <ul style="list-style-type: none"> <li>- Loopback IP: 10.10.10.20</li> <li>- Router ID: 2.2.2.2</li> <li>- Static route: 192.168.1.0/29, Next Hop: 10.10.1.6</li> <li>- BGP Peer: 192.168.1.2, Source Interface: loopback</li> </ul> Remote AS: 65201
Logical Interface Profile	VNET01_101_IFP (eth1/11, 1/12 and 1/13) <ul style="list-style-type: none"> <li>- Interface Type: SVI</li> <li>- Primary IP: 10.10.1.2/29</li> <li>- Secondary IP: 10.10.1.1/29</li> <li>- VLAN Encap: 501</li> </ul> VNET01_102_IFP (eth1/11, 1/12 and 1/13) <ul style="list-style-type: none"> <li>- Interface Type: SVI</li> <li>- Primary IP: 10.10.1.3/29</li> <li>- Secondary IP: 10.10.1.1/29</li> </ul>

Property	Name
	VLAN Encap: 501
External EPGs	VNET01_EXT_EPG - Export Route Control Subnet (0.0.0.0) External Subnet for External EPG (192.168.1.0/24)

## Create VLAN Pool for Azure Local L3 Domain

In this section, you will create a VLAN pool to enable connectivity to Azure Local.

To configure a VLAN pool to connect the Azure Local servers to the ACI leaf switches, follow these steps:

1. From the APIC top navigation menu, select **Fabric > Access Policies**.
2. From the left navigation pane, expand and select **Pools > VLAN**.
3. Right-click and select **Create VLAN Pool**.
4. In the **Create Pool** pop-up window, specify a Name (For example, **HCI\_VLAN\_POOL**) and for Allocation Mode, select **Static Allocation**.
5. For **Encap Blocks**, use the **[+]** button on the right to add VLANs to the VLAN pool. In the **Create Ranges** pop-up window, configure the VLANs that need to be configured from the leaf switches to the Azure Local servers. Leave the remaining parameters as is.
6. Click **OK**.
7. Click **Submit**.

The screenshot displays the APIC interface with the 'Fabric > Access Policies' navigation path. The 'Pools - VLAN' section is active, showing a 'Create VLAN Pool' dialog box. The dialog box has the following fields and options:

- Name:** HCI\_VLAN\_POOL
- Description:** optional
- Allocation Mode:** Dynamic Allocation (selected), Static Allocation
- Encap Blocks:** A table with columns for Allocation Mode and Role.

Below the 'Create VLAN Pool' dialog box, a 'Create Ranges' dialog box is open. It has the following fields and options:

- Type:** VLAN
- Description:** optional
- Range:** VLAN 400 - VLAN 600
- Allocation Mode:** Dynamic Allocation, Inherit allocMode from parent, Static Allocation
- Role:** External or On the wire encapsulations, Internal

Buttons for 'Cancel' and 'OK' are visible at the bottom of both dialog boxes.

## Configure L3 Domain for Azure Local

To create an L3 domain type and connect to Azure Local servers, follow these steps:

1. From the APIC top navigation menu, select **Fabric > Access Policies**.
2. From the left navigation pane, expand and select **Physical and External Domains > L3 Domains**.
3. Right-click **L3 Domains** and select **Create L3 Domain**.
4. In the **Create L3 Domain** pop-up window, specify a Name for the domain (For example, **HCI\_EXT\_L3DOM**). For the VLAN pool, select the previously created VLAN pool (For example, **HCI\_VLAN\_POOL**) from the drop-down list.

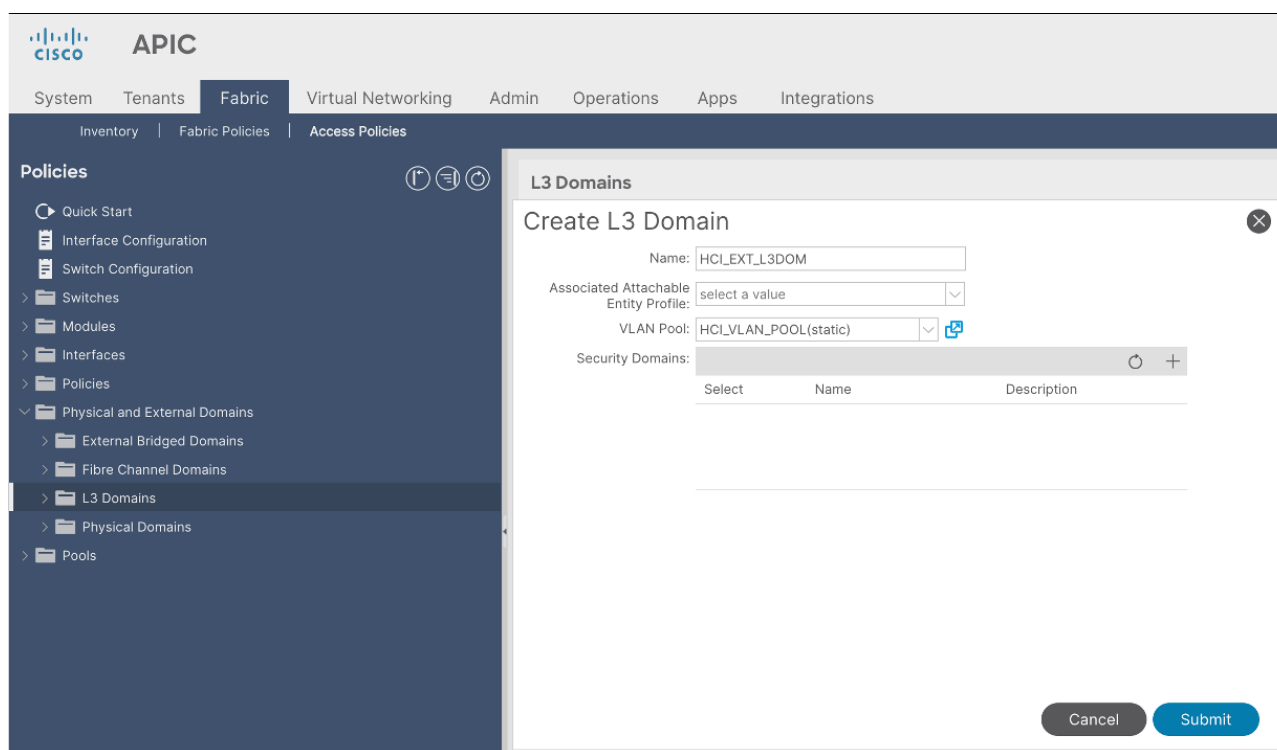

5. Click **Submit**.

## Create Attachable Access Entity Profile for Azure Local L3 Domain

To create an Attachable Access Entity Profile (AAEP), follow these steps:

1. From the APIC top navigation menu, select **Fabric > Access Policies**.
2. From the left navigation pane, expand and select **Policies > Global > Attachable Access Entity Profiles**.
3. Right-click and select **Create Attachable Access Entity Profile**.
4. In the **Create Attachable Access Entity Profile** pop-up window, specify a Name (For example, **HCI\_AAEP**) and **uncheck "Enable Infrastructure VLAN" and "Association to Interfaces"**.
5. **For the Domains**, click the **[+]** on the right side of the window and select the previously created domain from the drop-down list below **Domain Profile**.
6. Click **Update**.

7. You should now see the selected domain and the associated VLAN pool as shown below.
8. Click **Next**. This profile is not associated with any interfaces at this time because “Association to Interfaces” was unchecked in step 4 above. They can be associated once the interfaces are configured in an upcoming section.

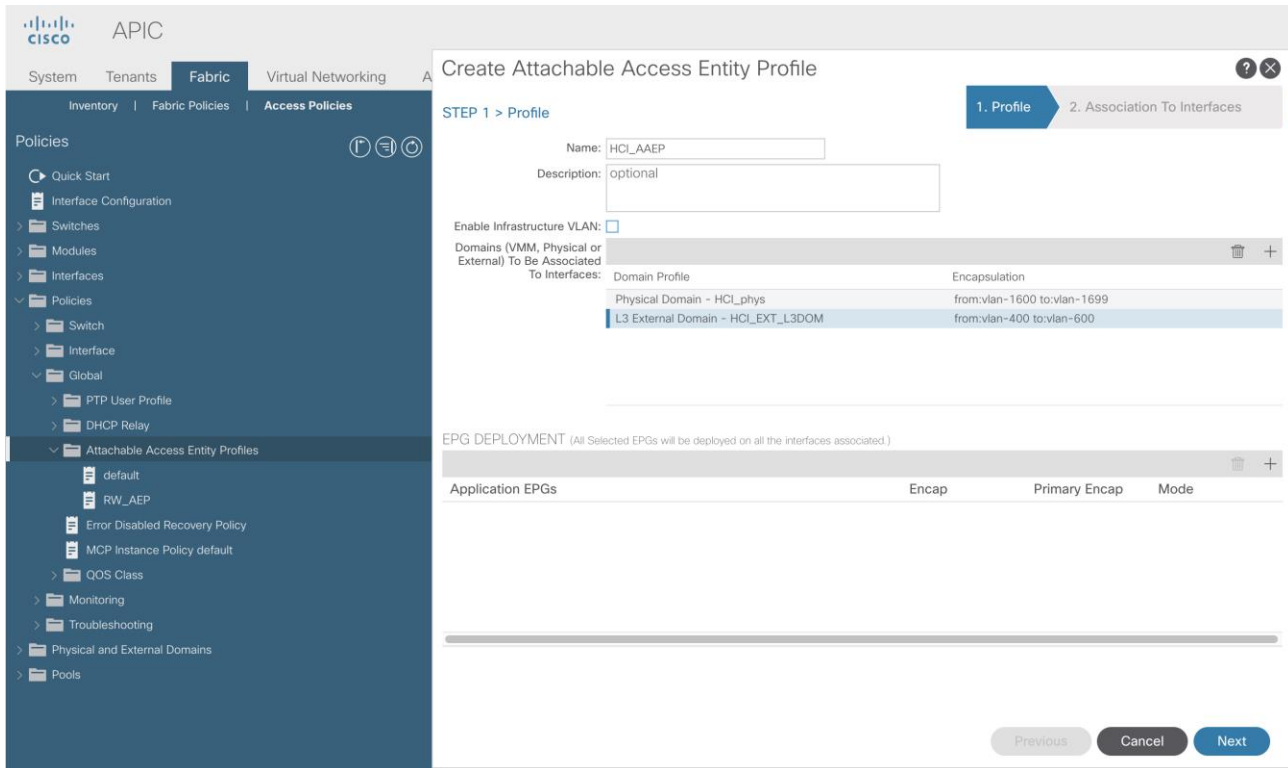

9. Click **Finish**.

Perform the following configurations that are common for VLAN-based tenant network and Microsoft SDN-based network in Azure Local:

- [Create LLDP policy](#)
- [Create LLDP Interface Policy](#)
- [Create Interface Priority Flow Control Policy](#)
- [Create Interface Policy Group for Interfaces connected to Azure Local servers](#)
- [Associate Interface Policy Group for Interfaces connected to Azure Local servers](#)
- [Configure QoS](#)

The Management VLAN, Storage VLANs, and the PA VLAN are the VLAN-based networks for the Azure Local with SDN. The next sub-section covers an L3Out configuration example for PA network deployment. For the deployment of Management EPGs corresponding to the Management VLAN and Storage EPGs corresponding to the Storage VLANs, please refer “Configure EPGs” section” of this document.

## Cisco ACI Configuration for PA Network and SLB Connectivity

This section explains how to configure L3Out in Cisco ACI to enable PA Network and SLB MUX VMs connectivity. To create an L3Out, follow these steps:

1. From the APIC top navigation menu, select **Tenants > common** (or select an existing tenant where you want to configure the PA L3Out).
2. From the left navigation pane, expand and select **Networking > L3Outs**.
3. Right-click and select **Create L3Out**.
4. In the **Name** field, specify a Name (For example, **Cluster\_01\_PA\_L3Out**), select a VRF name (In this example, **Common\_VRF**), select a previously created **L3 domain** from the drop-down list (In this example, **HCI\_EXT\_L3DOM**).
5. Check the **BGP** checkbox and click **Next**.

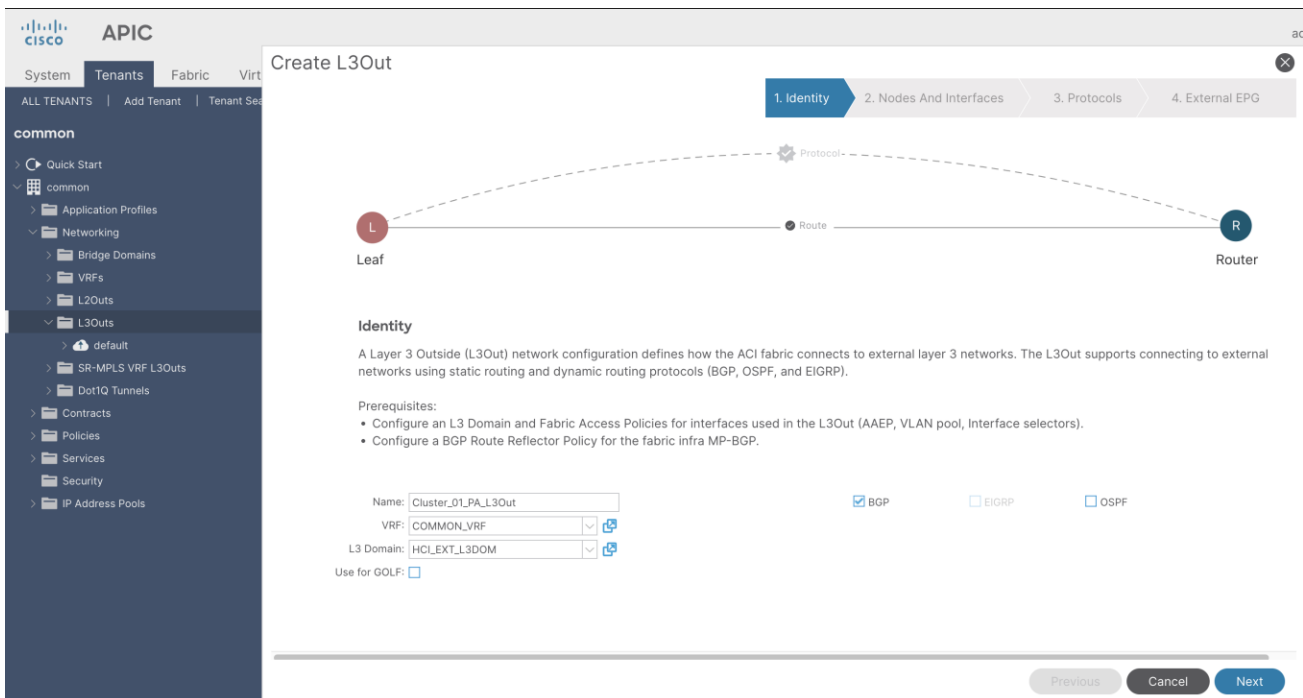

6. Uncheck the **Use Defaults** checkbox to manually specify a name in the **Node Profile Name** field (In this example, **Cluster\_01\_PA\_101\_NP**) and **Interface Profile Name** field (In this example, **Cluster\_01\_PA\_101\_IFP**).

## Create L3Out

1. Identity **2. Nodes And Interfaces** 3. Protocols 4. External EPG

Use Defaults:

Node Profile Name:

Interface Types

Layer 3:

Layer 2:

Nodes

Node ID	Router ID	Loopback Address				
<input type="text" value="LEAF1 (Node-101)"/>	<input type="text" value="1.1.1.1"/>	<input type="text"/>	<input type="button" value="+ Hide Interfaces"/>			
Leave empty to not configure any Loopback						
Interface	Interface Profile Name	Encap	MTU (bytes)	IP Address		
<input type="text" value="eth1/11"/>	<input type="text" value="Cluster_01_PA_101_IFP"/>	<input type="text" value="VLAN"/>	<input type="text" value="401"/>	<input type="text" value="9216"/>	<input type="text" value="10.2.1.2/24"/>	<input type="button" value="🗑️"/> <input type="button" value="⊕"/>
<small>Ex: eth1/1 or topology/pod-1/paths-101/pathep-[eth1/23]</small>						
<input type="text" value="eth1/12"/>	<input type="text" value="Cluster_01_PA_101_IFP"/>	<input type="text" value="VLAN"/>	<input type="text" value="401"/>	<input type="text" value="9216"/>	<input type="text" value="10.2.1.2/24"/>	<input type="button" value="🗑️"/> <input type="button" value="⊕"/>
<small>Ex: eth1/1 or topology/pod-1/paths-101/pathep-[eth1/23]</small>						
<input type="text" value="eth1/13"/>	<input type="text" value="Cluster_01_PA_101_IFP"/>	<input type="text" value="VLAN"/>	<input type="text" value="401"/>	<input type="text" value="9216"/>	<input type="text" value="10.2.1.2/24"/>	<input type="button" value="🗑️"/> <input type="button" value="⊕"/>
<small>Ex: eth1/1 or topology/pod-1/paths-101/pathep-[eth1/23]</small>						

- In the **Interface Types** section, select **SVI** for **Layer 3** and **Port** for **Layer 2**.
- In the **Nodes** section, input all the details related to the first leaf switch (In this example, **Node ID** as **Node-101** and **Router ID** as **1.1.1.1**, leave the **Loopback Address** field blank).
- Click + in the second row to add additional interfaces on the same Node (In this example, there are three servers connecting on three interfaces of one leaf switch, **eth1/11**, **1/12** and **1/13**).
- From the drop-down list, select the interfaces connecting to the servers, specify the **Interface Profile Name**, **Encap**, **Encap value**, **MTU** and **IP address**. The Azure Local servers uses maximum MTU size as 9174, hence the MTU configured on the TOR switches must be same or more than 9174 (In this example, Interface Profile Name is **Cluster\_01\_PA\_101\_IFP**, Encap is **VLAN**, Encap value is **401**, MTU is **9216** and IP address is **10.2.1.2/24**).
- Enter the same values for all the interfaces and click **Next**. The equivalent configurations for the second leaf will be added later though it is also possible to add them through this wizard.
- Click on **Next** without entering any BGP related information on this page.



### Create L3Out

1. Identity 2. Nodes And Interfaces 3. Protocols 4. External EPG

**Protocol Associations**

BGP

Loopback Policies

Node Profile: Cluster\_01\_PA\_101\_NP Hide Policy

Nodes	Peer Address	EBGP Multihop TTL	Remote ASN
101	<input type="text"/>	<input type="text"/>	<input type="text"/>

Interface Policies

Node ID: 101 Hide Policy

Interface	Peer Address	EBGP Multihop TTL	Remote ASN
1/11	<input type="text"/>	<input type="text"/>	<input type="text"/>
1/12	<input type="text"/>	<input type="text"/>	<input type="text"/>
1/13	<input type="text"/>	<input type="text"/>	<input type="text"/>

Previous Cancel Next

13. Click on **Finish** on the **External EPG** page without making any changes at this moment. The External EPG will be created at a later stage.

### Create L3Out

1. Identity 2. Nodes And Interfaces 3. Protocols 4. External EPG

**External EPG**

The L3Out Network or External EPG is used for traffic classification, contract associations, and route control policies. Classification is matching external networks to this EPG for applying contracts. Route control policies are used for filtering dynamic routes exchanged between the ACI fabric and external devices, and leaked into other VRFs in the fabric.

Name:

Provided Contract:

Consumed Contract:

Default EPG for all external networks:

Previous Cancel Finish

- From the APIC top navigation menu, select **Tenants > common > Networking > L3Outs > L3Out Name (in this example, Cluster\_01\_PA\_L3Out) > Logical Node Profiles (in this example, Cluster\_01\_PA\_101\_NP) > Logical Interface Profiles (in this example, Cluster\_01\_PA\_101\_IFP) > SVI**.

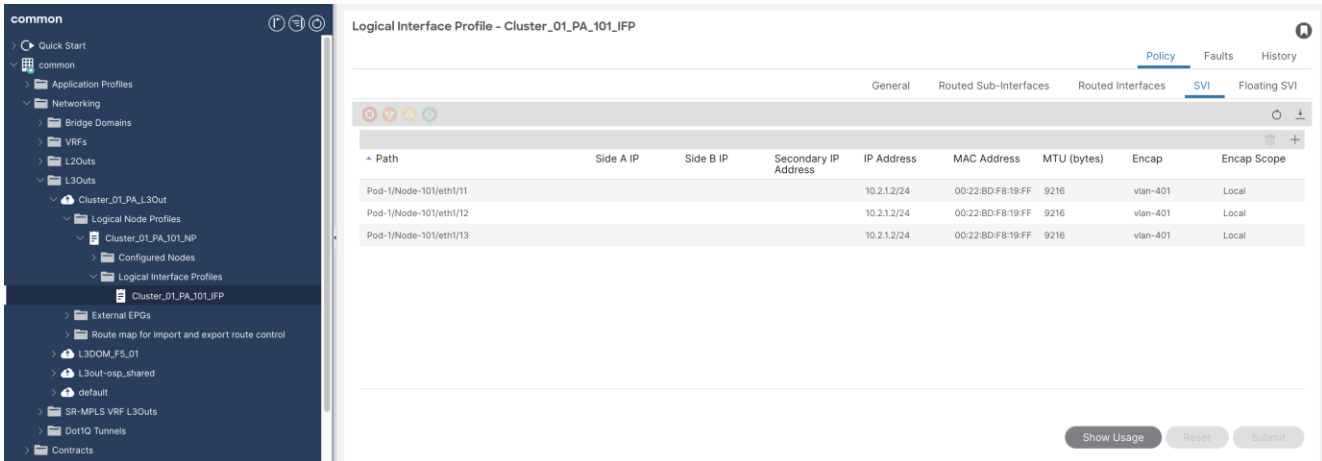

- Double-click on the first interface and click **+** to add the **IPv4 Secondary Addresses**. This will work as a virtual IP address, and it will be common across both the leaf switches (In this example, double click on **eth1/11** and enter secondary IP address as **10.2.1.1/24**).

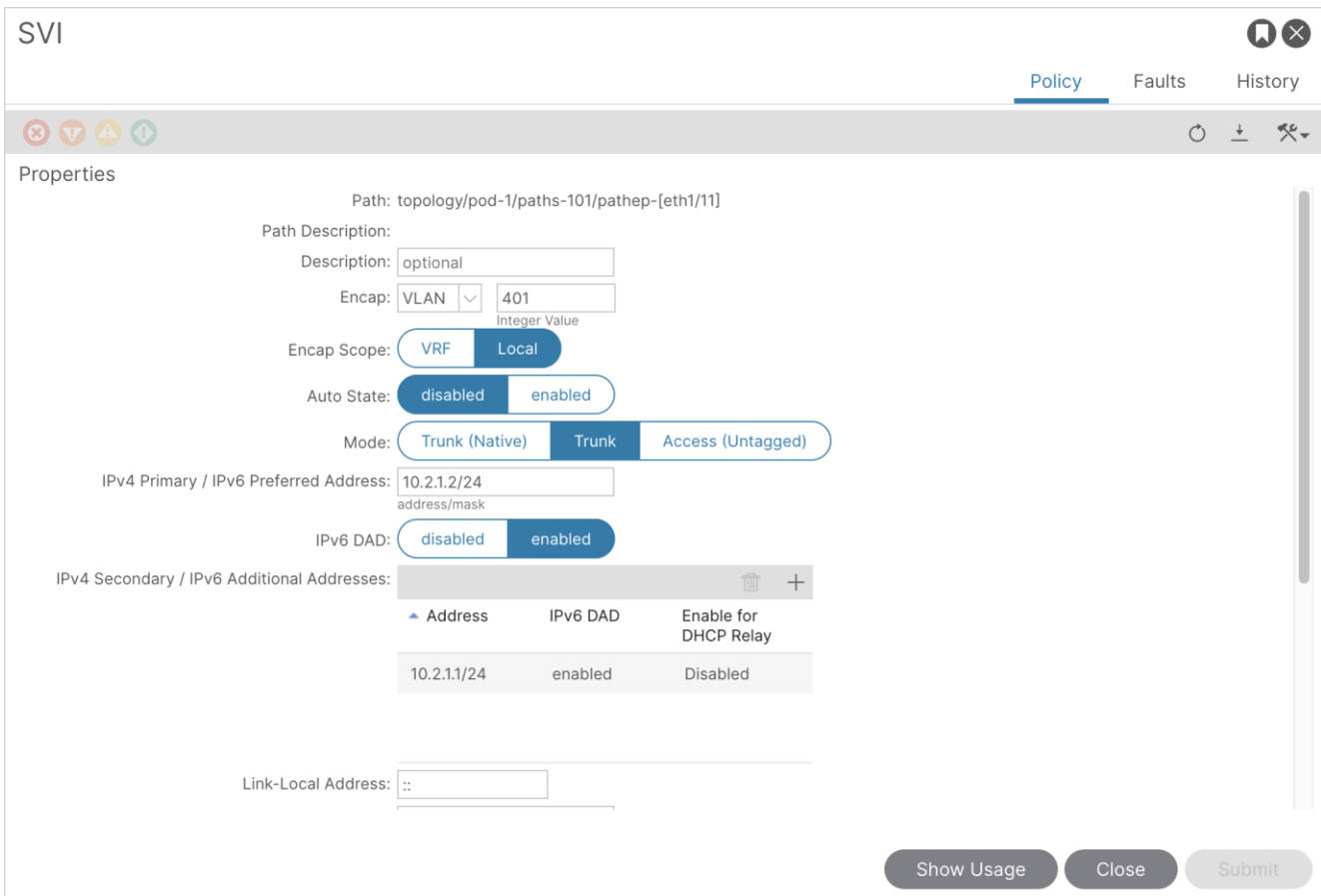

16. Scroll down and click **+** to add the **BGP Peer Connectivity Profiles**. The BGP peer address will be the SLB MUX VMs IP address.

17. Enter the **Peer Address** and **Remote AS** while keeping all the values to their default and click on **Submit** (In this example, Peer Address is **10.2.1.4** and Remote AS is **65002**).

Create Peer Connectivity Profile ✕

Peer Address:   
address

Description:

Remote AS:

Admin State:  Disabled  Enabled

BGP Controls:

- Allow Self AS
- AS override
- Disable Peer AS Check
- Next-hop Self
- Send Community
- Send Extended Community
- Send Domain Path

Capability:  Receive Additional Paths

Password:

Confirm Password:

Allowed Self AS Count:

Peer Controls:  Bidirectional Forwarding Detection  
 Disable Connected Check

Address Type Controls:  AF Mcast  
 AF Ucast

EBGP Multihop TTL:

Weight for routes from this neighbor:

18. Repeat step 16 and step 17 to add multiple BGP peers and click **Close** (In this example, **10.2.1.5** and **10.2.1.6**).

Properties

Link-Local Address:

MAC Address:

MTU (bytes):

Target DSCP:

External Bridge Group Profile:

BGP Peer Connectivity Profiles:

Peer IP Address	Peer Controls
10.2.1.4	
10.2.1.5	
10.2.1.6	

Rogue Exception MAC Group:

Exclude all MACs from Rogue EP Control:

[Show Usage](#) [Close](#) [Submit](#)

19. Repeat step 15 to step 18 for the remaining interfaces (In this example, **eth1/12** and **eth1/13**).

**common**

- ↳ L3Outs
  - ↳ Cluster\_01\_PA\_L3Out
    - ↳ Logical Node Profiles
      - ↳ Cluster\_01\_PA\_101\_NP
        - ↳ Configured Nodes
          - ↳ Logical Interface Profiles
            - ↳ Cluster\_01\_PA\_101\_IFP
              - ↳ BGP Peer 10.2.1.4- Node-101/1/11
              - ↳ BGP Peer 10.2.1.4- Node-101/1/12
              - ↳ BGP Peer 10.2.1.4- Node-101/1/13
              - ↳ BGP Peer 10.2.1.5- Node-101/1/11
              - ↳ BGP Peer 10.2.1.5- Node-101/1/12
              - ↳ BGP Peer 10.2.1.5- Node-101/1/13
              - ↳ BGP Peer 10.2.1.6- Node-101/1/11
              - ↳ BGP Peer 10.2.1.6- Node-101/1/12
              - ↳ BGP Peer 10.2.1.6- Node-101/1/13
            - ↳ External EPGs
            - ↳ Route map for import and export route control
            - ↳ L3DOM\_F5\_01
            - ↳ L3out-osp\_shared
            - ↳ default
            - ↳ SR-MPLS VRF L3Outs

Logical Interface Profile - Cluster\_01\_PA\_101\_IFP

Policy | Faults | History

General | Routed Sub-Interfaces | Routed Interfaces | **SVI** | Floating SVI

Path	Side A IP	Side B IP	Secondary IP Address	IP Address	MAC Address	MTU (bytes)	Encap	Encap Scope
Pod-1/Node-101/eth1/11			10.2.1.2/24	10.2.1.2/24	00:22:BD:F8:19:FF	9216	vlan-401	Local
Pod-1/Node-101/eth1/12			10.2.1.2/24	10.2.1.2/24	00:22:BD:F8:19:FF	9216	vlan-401	Local
Pod-1/Node-101/eth1/13			10.2.1.2/24	10.2.1.2/24	00:22:BD:F8:19:FF	9216	vlan-401	Local

[Show Usage](#) [Reset](#) [Submit](#)

20. Notice all the **BGP Connectivity Profiles** are seen on the leaf side under **Logical Interface Profile** (In this example, there are nine BGP Connectivity Profiles considering three BGP peers on per interface).

21. Navigate to **Tenants > common > Networking > L3Outs > L3Out Name** (In this example, **Cluster\_01\_PA\_L3Out**) > **Logical Node Profiles**.

22. Right-click and select **Create Node Profile**. This will create a Node Profile for the second leaf switch.

23. Specify the **Name** and click + to add the **Nodes** details (In this example, the name will be **Cluster\_01\_PA\_102\_NP**).

## Create Node Profile



Name: Cluster\_01\_PA\_102\_NP

Description: optional

Target DSCP: Unspecified

BGP Timers: select a value

Nodes:



Node ID	Router ID	Static Routes
---------	-----------	---------------

BGP Peer Connectivity Profiles:



Peer IP Address	Peer Controls
-----------------	---------------

Cancel

Submit

24. Specify the **Node ID** and **Router ID**. Uncheck the **Use Router ID as Loopback Address** checkbox and click **OK** in this example, Node ID is **102**, Router ID is **2.2.2.2**).

## Select Node



Node ID: LEAF2 (Node-102)

Router ID: 2.2.2.2

Use Router ID as Loopback Address:

Loopback Addresses:

IP

Static Routes:

IP Address	Description	Next Hop IP	Track Policy
------------	-------------	-------------	--------------

Cancel

OK

25. Click **Submit** on the Node Profile page.
26. Navigate to **Tenants > common > Networking > L3Outs > L3Out Name** (In this example, **Cluster\_01\_PA\_L3Out**) > **Logical Node Profiles** (in this example, **Cluster\_01\_PA\_102\_NP**) > **Logical Interface Profiles**.
27. Right-click and select **Create Interface Profile**.
28. Specify the **Name**, select the **SVI** tab (In this example, the name is **Cluster\_01\_PA\_102\_IFP**).

# Create Interface Profile



1. Identity

## STEP 1 > Identity

Name:

Description:

Routed Sub-Interfaces   Routed Interfaces   **SVI**   Floating SVI

SVI Interfaces					
Path	IP Address	MAC Address	MTU (bytes)		

Config Protocol Profiles:

Config Advance Protocol:

29. Click + to create the SVI interface.

## Select SVI



Path Type: **Port** Direct Port Channel Virtual Port Channel

Node: LEAF2 (Node-102)   
 ex: topology/pod-1/node-1

Path: eth1/11   
 ex: topology/pod-1/paths-101/pathep-[eth1/23]

Description: optional

Encap: VLAN **401**   
 Integer Value

Encap Scope: VRF **Local**

Auto State: disabled **enabled**

Mode: Trunk (Native) **Trunk** Access (Untagged)

IPv4 Primary / IPv6 Preferred Address: 10.2.1.3/24

Link-Local Address:

IPv4 Secondary / IPv6 Additional Addresses:

Address	IPv6 DAD	Enable for DHCP Relay
10.2.1.1/24	enabled	Disabled

MAC Address: 00:22:BD:F8:19:FF

MTU (bytes): 9216

Target DSCP: Unspecified

External Bridge Group Profile: select an option

BGP Peer Connectivity Profiles:

Peer IP Address	Peer Controls
10.2.1.4	
10.2.1.5	
10.2.1.6	

Rogue Exception MAC Group: select an option

30. Select the **Path Type**, specify the **Node**, **Path**, **Encap Vlan id**, **IPV4 Primary Address**, **IPV4 Secondary Addresses**, **MTU**, and **BGP Peer Connectivity Profiles**, and click **OK** at the bottom of the page (In this example, Path type is **Port**, Node is **102**, Path is **eth1/11**, Encap Vlan id is **401**, IPV4 Primary Address is **10.2.1.3/24**, IPV4 Secondary Address is **10.2.1.1/24**, MTU is **9216** bytes, BGP Peer IPs are **10.2.1.4**, **10.2.1.5** and **10.2.1.6**, and BGP AS number is **65002**).

31. Repeat step 29 and step 30 for the remaining interfaces and click **Finish** (In this example, interface **eth1/12** and **eth1/13**).



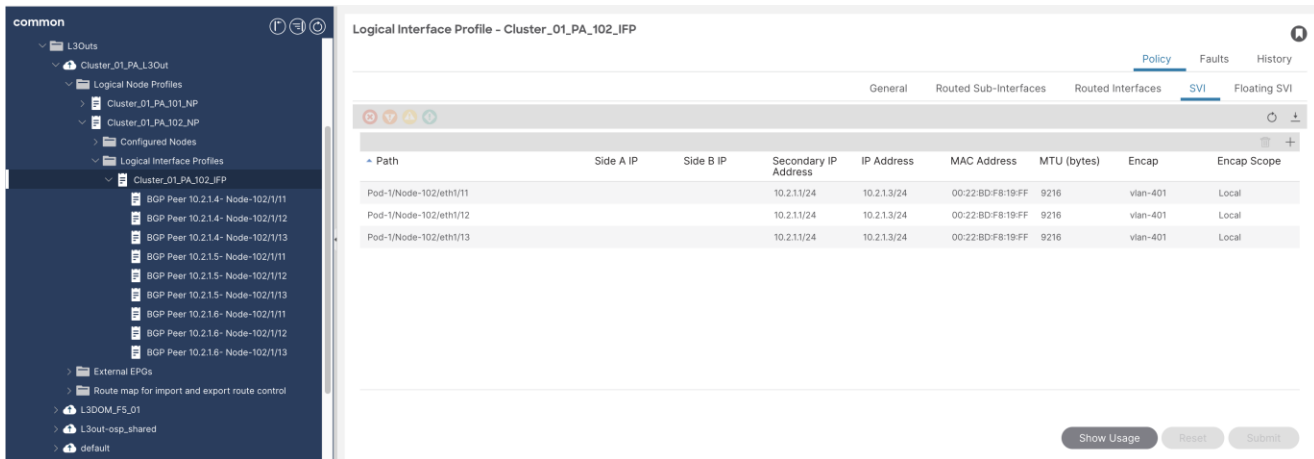

32. From the APIC top navigation menu, select **Tenants > common > Networking > L3Outs > L3Out Name** (In this example, **Cluster\_01\_PA\_L3Out**) > **External EPGs**.

33. Right-click and select **Create External EPG**. Specify the **Name** (In this example, **Cluster\_01\_PA\_EXT\_EPG**).

34. Click + and add **Subnet** which is to be advertised by ACI Leaf (or received) to the SLB MUX VMs via this L3Out (In this example, IP subnet **0.0.0.0/0** is advertised by ACI Leaf and hence marked as **Export Route Control Subnet**).

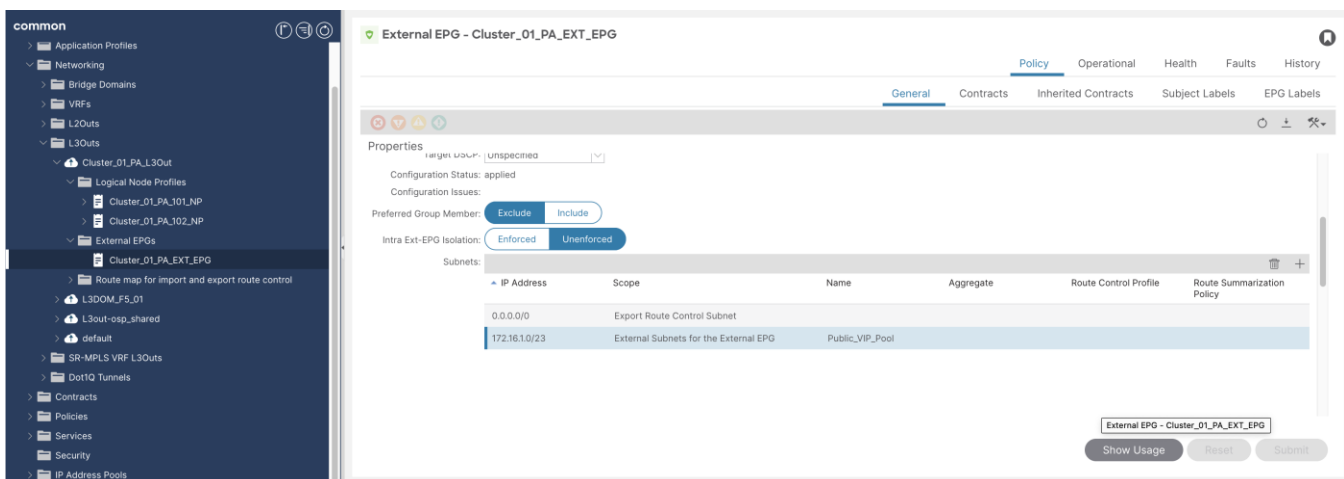

Subnets which are advertised by the SLB MUX VMs such as Public VIP pool can be added in the **Subnet** section of the External EPG and marked as **External Subnet for External EPG** (In this example, IP subnet **172.16.1.0/23** is configured as Public VIP Pool on SLB MUX VMs and hence marked on Cisco ACI leaf as **External Subnet**).

[Configure Contracts](#) as discussed in the previous sections. A contract is necessary to permit traffic between the L3Out external EPG and other L3Out External EPGs or EPGs part of the ACI fabric.

Contracts can be added to the **External EPGs** from the following path - **Tenants > common > Networking > L3Outs > L3Out Name** (In this example, **Cluster\_01\_PA\_L3Out**) > **External EPGs > External EPG Name** (In this example, **Cluster\_01\_EXT\_EPG**) > **Policy > Contracts > Add Provided Contract or Add Consumed Contract**.

## Cisco ACI Configuration for Azure Local VNET & Gateway VM Connectivity

The previous section covered the deployment of EPGs and L3Out to build the Azure Local underlay network. This section explains how to configure Cisco ACI to support customer's workload deployed in Azure Local. In this example, a Cisco ACI tenant, a VRF, and an L3Out that connects to the Azure HCI VNET are configured. The following are the configuration steps:

1. From the APIC top navigation menu, select **Tenants > Add Tenant**.
2. In the **Create Tenant** dialog box, specify a Name (For example, **HCI1\_tenant1**).
3. In the **VRF Name** field, enter the VRF name and click **Finish** (For example, **VRF1**).

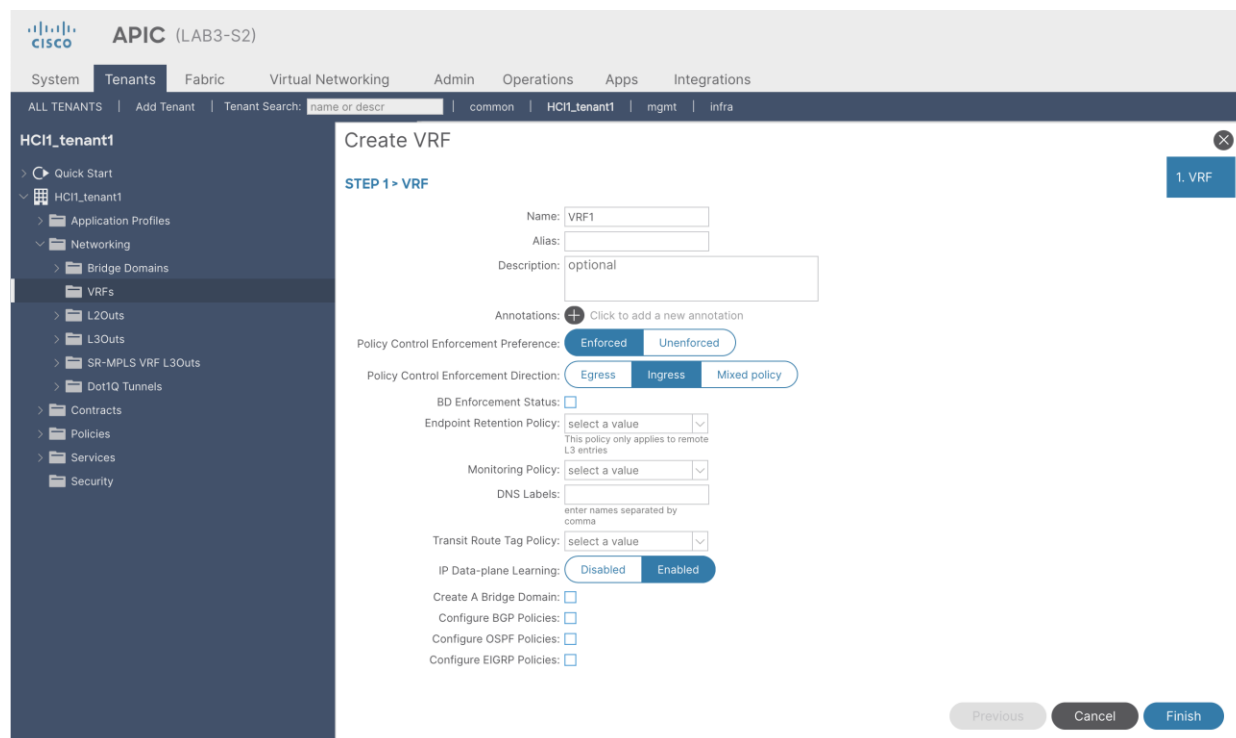

4. From the left navigation pane, expand and select **Networking > L3Outs**.
5. Right-click and select **Create L3Out**.
6. In the **Name** field, specify a Name (For example, **VNET01\_L3Out**), select a VRF name (In this example, **VRF1**), and select a previously created **L3 domain** from the drop-down list (In this example, **HCI\_EXT\_L3DOM**).
7. Check the **BGP** checkbox and click **Next**.

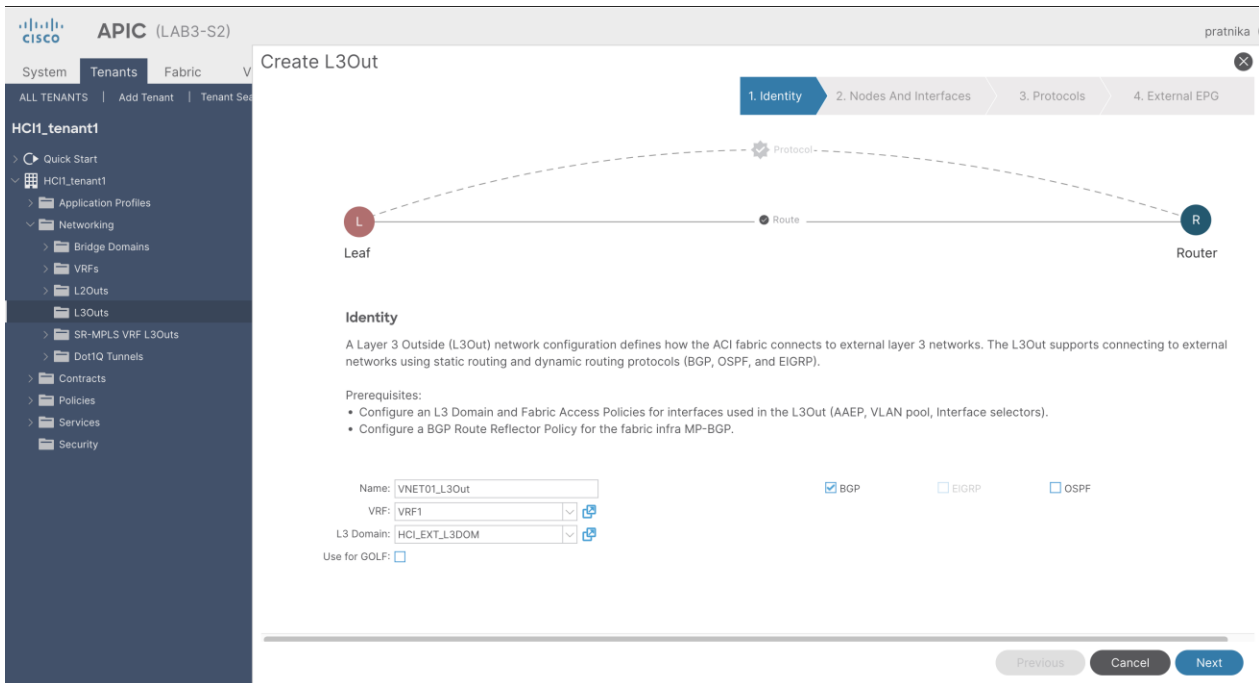

- Uncheck the **Use Defaults** checkbox to manually specify a name in the **Node Profile Name** field (In this example, **VNET01\_NP**).

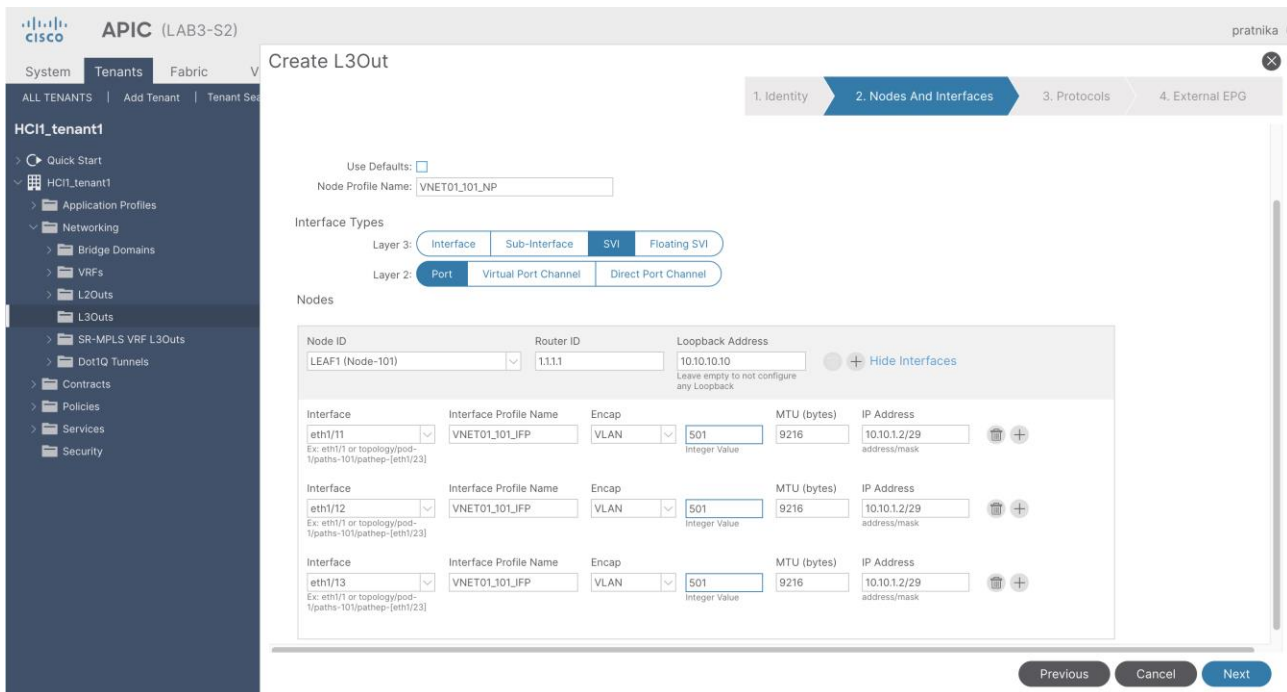

- In the **Interface Types** section, select **SVI** for **Layer 3** and **Port** for **Layer 2**.
- In the **Nodes** section, input all the details related to the first leaf switch (In this example, **Node ID** as **Node-101**, **Router ID** as **1.1.1.1**, and **Loopback Address** as **10.10.10.10**).
- Click **+** in the second row to add additional interfaces on the same Node (In this example, there are three servers connecting on three interfaces of one leaf switch, **eth1/11**, **1/12** and **1/13**).

12. From the drop-down list, select the interfaces connecting to the servers, specify the **Interface Profile Name, Encap, Encap value, MTU, and IP address**. The Azure Local servers uses maximum MTU size as 9174, hence the MTU configured on the TOR switches must be same or more than 9174 (In this example, values are **VNET01\_101\_IFP, VLAN, 501, 9216 and 10.10.1.2/29**).
13. Enter the same values for all the interfaces belonging to the first Node.
14. Click + in the first row to add additional Node and input all the details regarding the second leaf switch (In this example, **Node ID** as 102, **Router ID** as **2.2.2.2**, and **Loopback Address** as **10.10.10.20**).
15. Click + to add additional interfaces below the second Node (In this example, there are three interfaces **eth1/11, eth1/12, and eth1/13** on second leaf connecting to Azure Local servers).
16. From the drop-down list, select the interfaces connecting to the servers, specify the **Interface Profile Name, Encap, Encap value, MTU, and IP address** (In this example, values are **VNET01\_102\_IFP, VLAN, 501, 9216 and 10.10.1.3/29**).

The screenshot shows a configuration form with the following fields and values:

- Node ID:** LEAF2 (Node-102)
- Router ID:** 2.2.2.2
- Loopback Address:** 10.10.10.20
- Buttons:** Hide Interfaces (with a plus icon)

Interface	Interface Profile Name	Encap	MTU (bytes)	IP Address
eth1/11 <small>Ex: eth1/1 or topology/pod-1/paths-101/pathep-[eth1/23]</small>	VNET01_102_IFP	VLAN	9216	10.10.1.3/29 <small>address/mask</small>
eth1/12 <small>Ex: eth1/1 or topology/pod-1/paths-101/pathep-[eth1/23]</small>	VNET01_102_IFP	VLAN	9216	10.10.1.3/29 <small>address/mask</small>
eth1/13 <small>Ex: eth1/1 or topology/pod-1/paths-101/pathep-[eth1/23]</small>	VNET01_102_IFP	VLAN	9216	10.10.1.3/29 <small>address/mask</small>

At the bottom of the form, there are three buttons: **Previous**, **Cancel**, and **Next**.

17. Click **Next**.
18. Enter the BGP-related information in the **Loopback Policies** section and leave the **Interface Policies** section blank.
19. Enter **Peer Address**, which is the IP address assigned to Gateway VM from the Gateway subnet inside the VNET (In this example, **192.168.1.2**).
20. Enter the **EBGP Multihop TTL**. This value must be greater than one as eBGP peer is not directly connected (It needs to be more than 1 because the peerings are not between directly connected IP addresses. In this example, it is configured as **4**).
21. Enter the **Remote ASN**. This will be the BGP ASN value configured on Azure Local VNET (In this example, it is configured as **65201**).
22. Click **Next**.

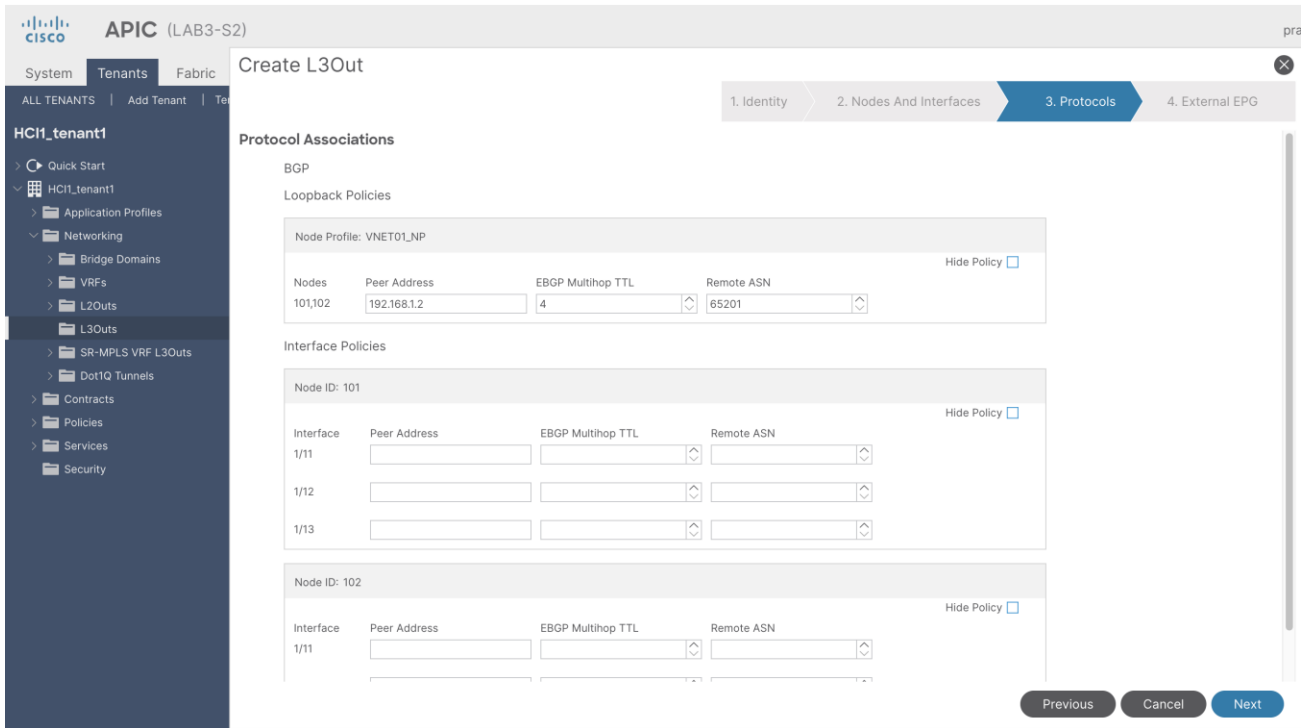

23. In the **Name** field, enter the name of the **External EPG** (In this example, **VNET01\_EXT\_EPG**).

24. Click **+** to add the subnets which are advertised or received via this L3Out. After the VNET's eBGP peering with the top of rack switches, the gateway VMs advertise the entire VNET subnet to the top of rack switches (In this example, **192.168.1.0/24** is the VNET subnet that is received by the ACI leaf switches and hence marked as **External Subnets for External EPG**. The ACI leaf switches are the only exit path for the Azure Local VNET to reach the external networks outside of Azure Local, hence **0.0.0.0/0** is advertised to Azure Local VNET and marked as **Export Route Control Subnet**).

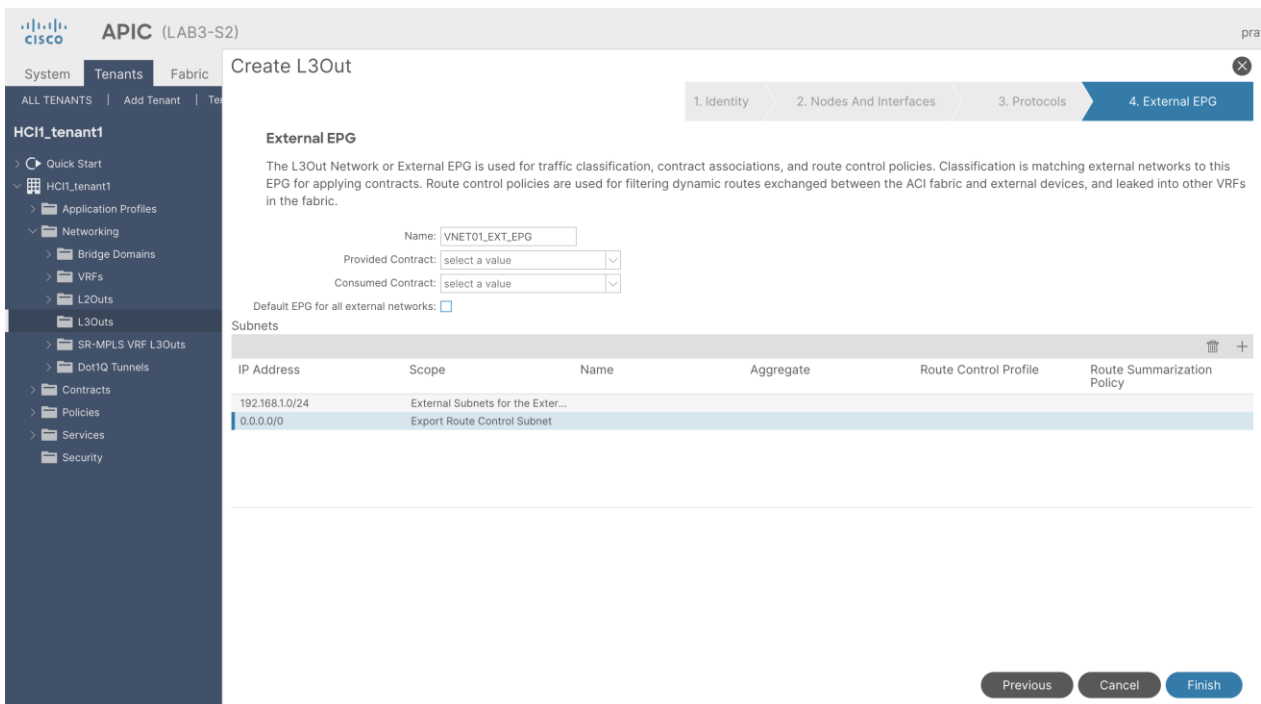

25. Click **Finish**. The contracts can be added at a later stage based on the traffic flow.
26. Navigate to **Tenants > HC11\_tenant1 > Networking > L3Outs > L3Out Name** (In this example, **VNET01\_L3Out**) > **Logical Node Profiles** (In this example, **VNET01\_NP**) > **Logical Interface Profiles** > **Interface Profile Name** (In this example, **VNET01\_101\_IFP**) > **Policy > SVI**.

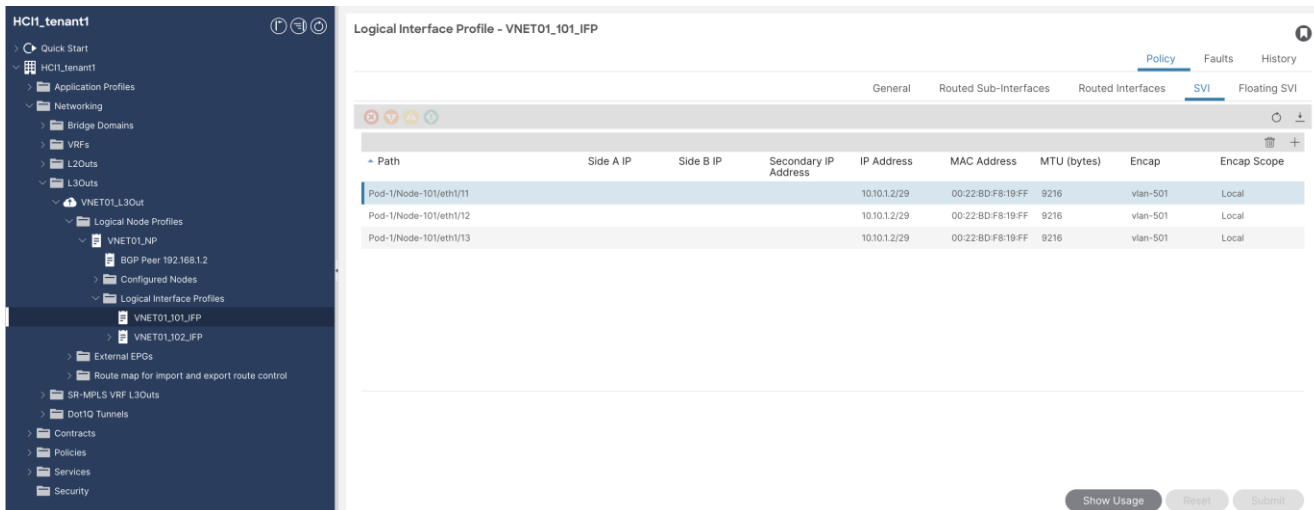

27. Double-click on the first interface (in this case, interface **eth1/11**).
28. Scroll down and click **+** to add **IPv4 Secondary / IPv6 Additional Addresses** (in this case, **10.10.1.1/29**).

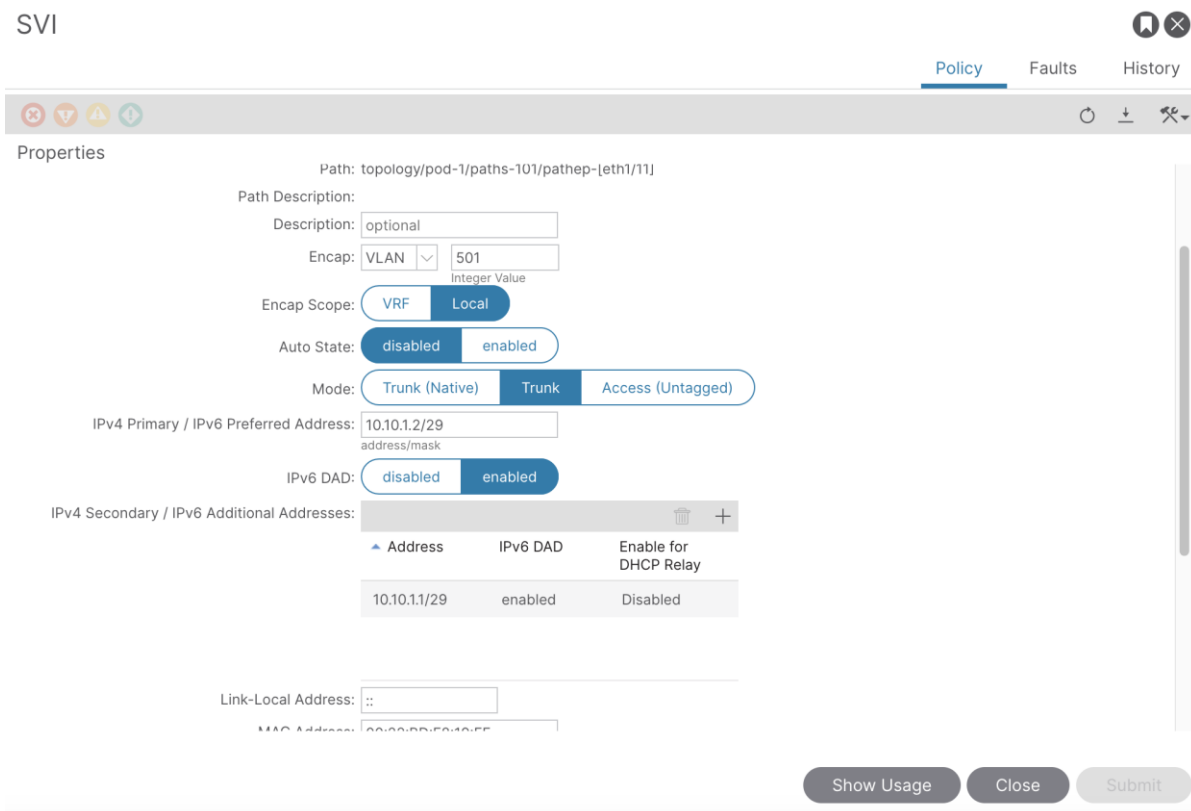

29. Click **Close** at the bottom of the page.

30. Repeat steps 27 to 29 for other interfaces (In this example, **eth1/12** and **eth1/13**).

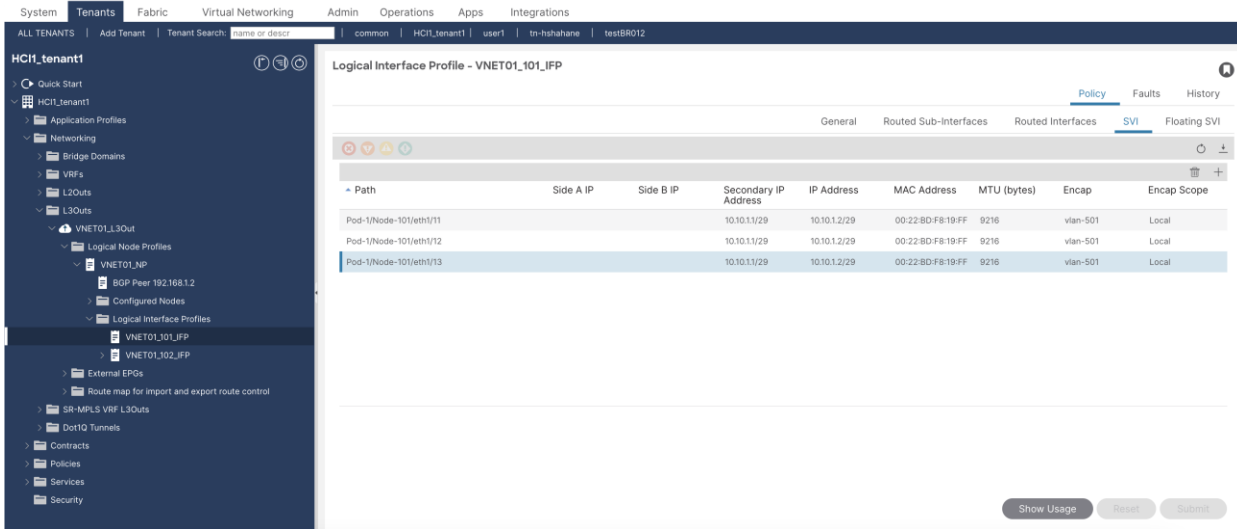

31. Navigate to second **Logical Interface Profile** via **Tenants > HCI1\_tenant1 > Networking > L3Outs > L3Out Name** (In this example, **VNET01\_L3Out**) > **Logical Node Profiles** (In this example, **VNET01\_NP**) > **Logical Interface Profiles > Interface Profile Name** (In this example, **VNET01\_102\_IFP**) > **Policy > SVI**.

32. Repeat step 27 to step 30 for the Node-102. (In this example, **eth1/11**, **eth1/12** and **eth1/13**, and **10.10.1.3** is the primary IP Address for Node-102).

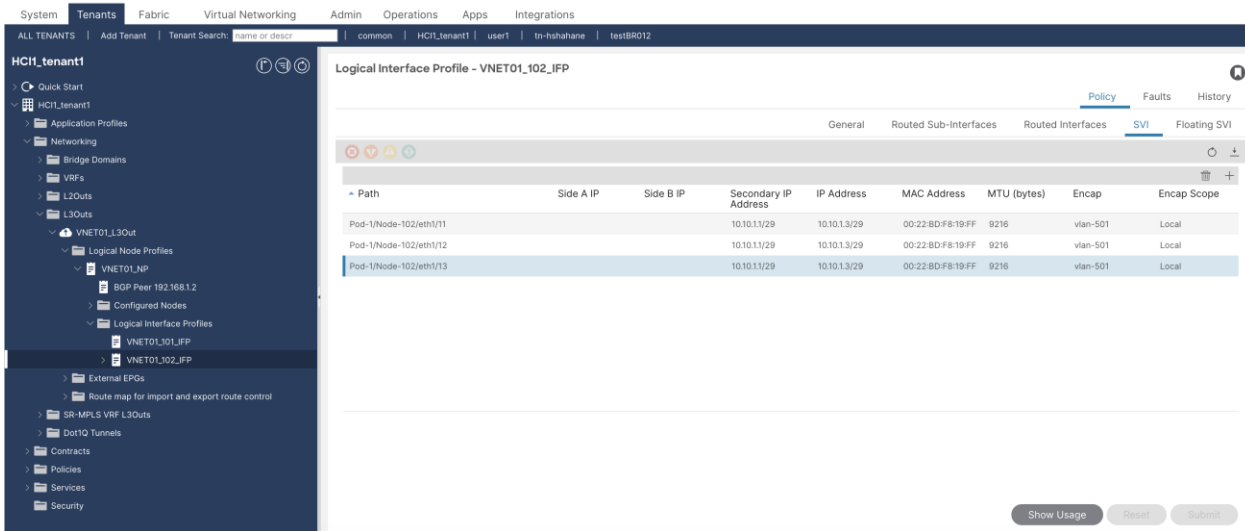

33. Navigate to **Tenants > HCI1\_tenant1 > Networking > L3Outs > L3Out Name** (In this example, **VNET01\_L3Out**) > **Logical Node Profiles** (In this example, **VNET01\_NP**) > **Configured Nodes > Node path** (In this example, **topology/pod-1/node-101**).

34. Click + to add **Static Routes**.

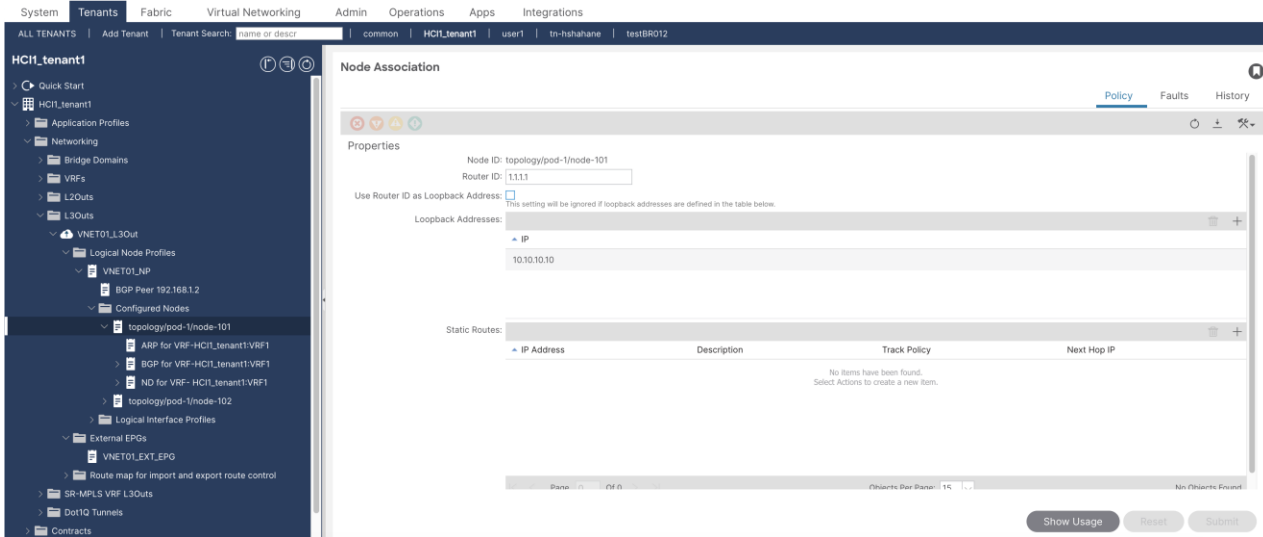

35. Add the **Gateway Subnet** in the **Prefix** field (In this example, **192.168.1.0/29** is the gateway subnet. Please note that the gateway subnet is part of the VNET subnet).

36. Click **+** to add the **Logical IP address** of the Azure Local VNET in the **Next Hop Addresses** field (In this example, **10.10.1.6**).

## Create Static Route

Prefix:

Description:

Fallback Preference:

Nexthop Type: Static Route

Route Control:  BFD

Track Policy:

Next Hop Addresses:

Next Hop IP	Preference
10.10.1.6	0

If there is no next hop address added, a NULL interface will be automatically created.

Cancel

Submit

37. Click **Submit**.

38. Navigate to **Tenants > HCI1\_tenant1 > Networking > L3Outs > L3Out Name** (In this example, **VNET01\_L3Out**) **> Logical Node Profiles** (In this example, **VNET01\_NP**) **> Configured Nodes > Node path** (In this example, **topology/pod-1/node-102**).



39. Repeat steps 34 to step 37 to add a static route on the second node.
40. **External EPG** can be created via wizard as shown in step 23. It can also be created from the following path – **Tenants > HCI1\_tenant1 > Networking > L3Outs > L3Out Name** (In this example, **VNET01\_L3Out**) > **External EPGs > External EPG Name** (In this example, **VNET01\_EXT\_EPG**).

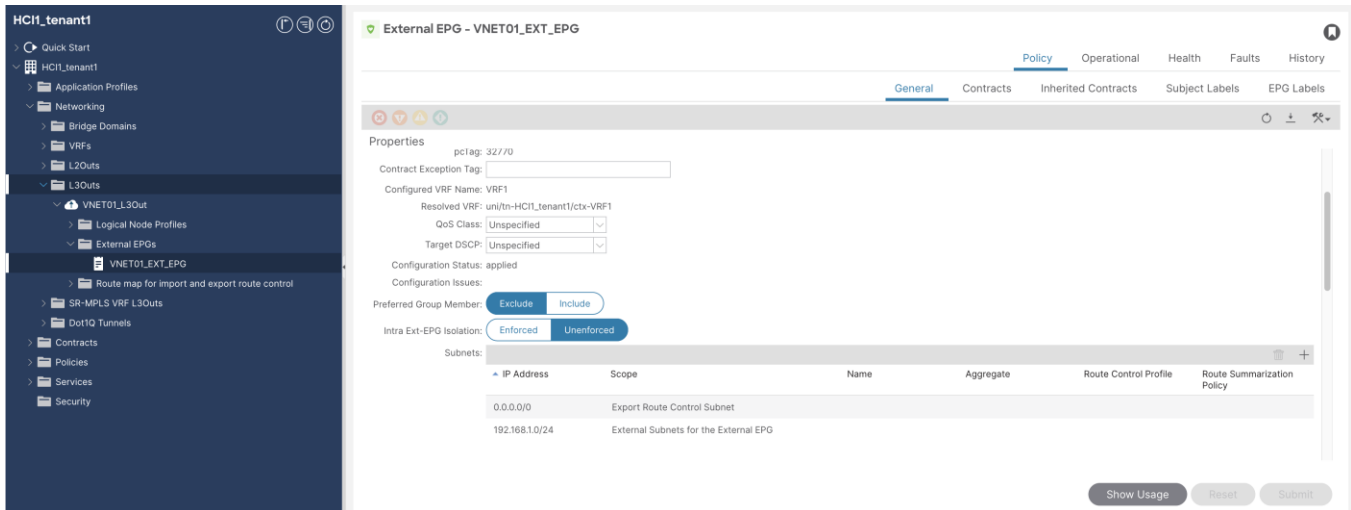

[Configure Contracts](#) as discussed in the previous sections. Contracts are necessary to permit traffic between the L3Out external EPG and other L3Out External EPGs or EPGs that are part of the ACI fabric.

Contracts can be added to the **External EPGs** from the following path – **Tenants > HCI1\_tenant1 > Networking > L3Outs > L3Out Name** (In this example, **VNET01\_L3Out**) > **External EPGs > External EPG Name** (In this example, **VNET01\_EXT\_EPG**) > **Policy > Contracts > Add Provided Contract or Add Consumed Contract**.

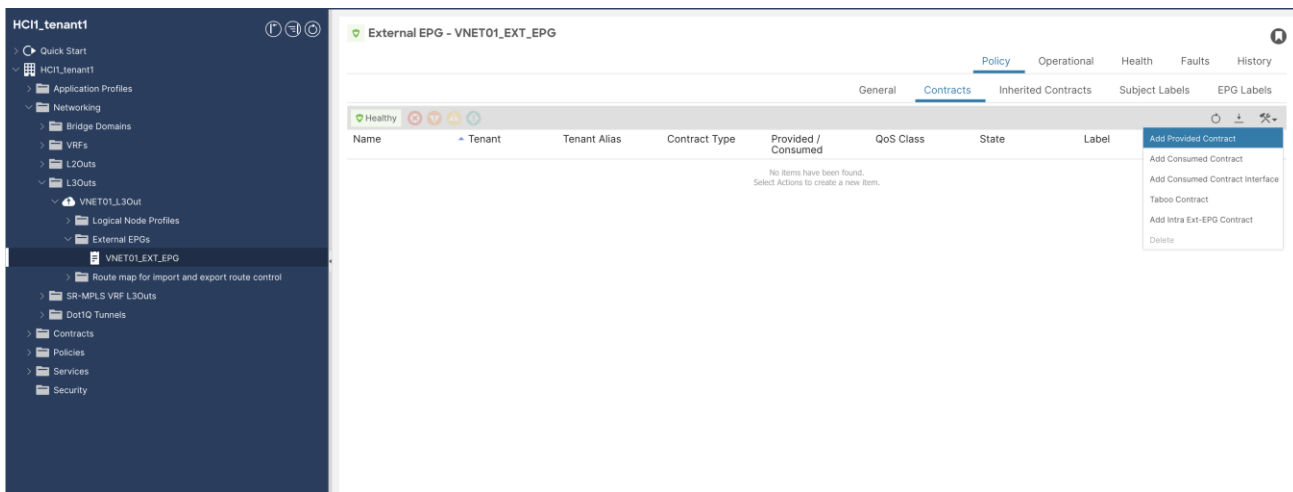

For more information

<http://www.cisco.com/go/aci>

# Revision history

Revision	Coverage	Date
Initial version	<ul style="list-style-type: none"><li>• Microsoft Azure Local 22H2</li><li>• Cisco ACI Release 6.0(3e)</li><li>• Cisco NX-OS Release 12.1.3b</li></ul>	12/19/2023
Added Appendix <a href="#">Design Example with Microsoft Software Defined Networking (SDN) in Azure Local</a>	<ul style="list-style-type: none"><li>• Microsoft Azure Local 22H2</li><li>• Cisco ACI Release 6.0(3e)</li></ul>	07/12/2024