



Configuring Port Channels

- [About Port Channels, on page 1](#)
- [Port Channels, on page 2](#)
- [Port-Channel Interfaces, on page 3](#)
- [Basic Settings, on page 4](#)
- [Compatibility Requirements, on page 5](#)
- [Load Balancing Using Port Channels, on page 6](#)
- [LACP, on page 8](#)
- [Prerequisites for Port Channeling, on page 12](#)
- [Guidelines and Limitations, on page 12](#)
- [Default Settings, on page 13](#)
- [Configuring Port Channels, on page 14](#)

About Port Channels

A port channel is an aggregation of multiple physical interfaces that creates a logical interface. You can bundle up to 8 individual active links into a port channel to provide increased bandwidth and redundancy. Port channeling also load balances traffic across these physical interfaces. The port channel stays operational as long as at least one physical interface within the port channel is operational.

A port channel is an aggregation of multiple physical interfaces that creates a logical interface. You can bundle up to 4 individual active links into a port channel to provide increased bandwidth and redundancy. Port channeling also load balances traffic across these physical interfaces. The port channel stays operational as long as at least one physical interface within the port channel is operational.

The allowed system wide limit for maximum port channel is 24. There are 6 port groups with each port group containing 8 ports. You can create a maximum of 4 port channels per port group. You can have a maximum of 8 physical ports, that belong to the same port group, bundled into a given port channel. You cannot create port channels from ports that belong to different port groups.

Table 1: Port group name and port group range

Port group name	Port group range
1	1/1 to 1/8
2	1/9 to 1/16

Port group name	Port group range
3	1/17 to 1/24
4	1/25 to 1/32
5	1/33 to 1/40
6	1/41 to 1/48

You can create a Layer 2 port channel by bundling compatible Layer 2 interfaces, or you can create Layer 3 port channels by bundling compatible Layer 3 interfaces. You cannot combine Layer 2 and Layer 3 interfaces in the same port channel.

You can also change the port channel from Layer 3 to Layer 2. See the *Configuring Layer 2 Interfaces* chapter for information about creating Layer 2 interfaces.

A Layer 2 port channel interface and its member ports can have different STP parameters. Changing the STP parameters of the port channel does not impact the STP parameters of the member ports because a port channel interface takes precedence if the member ports are bundled.



Note Members can be bundled into a port channel only if they belong to same **Quad**.



Note After a Layer 2 port becomes part of a port channel, all switchport configurations must be done on the port channel; you can no longer apply switchport configurations to individual port-channel members. You cannot apply Layer 3 configurations to an individual port-channel member either; you must apply the configuration to the entire port channel.

You can use static port channels, with no associated aggregation protocol, for a simplified configuration.

For more flexibility, you can use the Link Aggregation Control Protocol (LACP), which is defined in IEEE 802.3ad. When you use LACP, the link passes protocol packets. You cannot configure LACP on shared interfaces.

See the *LACP Overview* section for information about LACP.

Port Channels

A port channel bundles physical links into a channel group to create a single logical link that provides the aggregate bandwidth of up to 8 physical links. If a member port within a port channel fails, the traffic previously carried over the failed link switches to the remaining member ports within the port channel.

A port channel bundles physical links into a channel group to create a single logical link that provides the aggregate bandwidth of up to 4 physical links. If a member port within a port channel fails, the traffic previously carried over the failed link switches to the remaining member ports within the port channel.

However, you can enable the LACP to use port channels more flexibly. Configuring port channels with LACP and static port channels require a slightly different procedure (see the *Configuring Port Channels* section).



Note The device does not support Port Aggregation Protocol (PAgP) for port channels.

Each port can be in only one port channel. All the ports in a port channel must be compatible; they must use the same speed and duplex mode (see the *Compatibility Requirements* section). When you run static port channels with no aggregation protocol, the physical links are all in the on channel mode; you cannot change this mode without enabling LACP (see the *Port-Channel Modes* section).

You can create port channels directly by creating the port-channel interface, or you can create a channel group that acts to aggregate individual ports into a bundle. When you associate an interface with a channel group, the software creates a matching port channel automatically if the port channel does not already exist. In this instance, the port channel assumes the Layer 2 or Layer 3 configuration of the first interface. You can also create the port channel first. In this instance, the Cisco NX-OS software creates an empty channel group with the same channel number as the port channel and takes the default Layer 2 or Layer 3 configuration, as well as the compatibility configuration (see the *Compatibility Requirements* section).



Note The port channel is operationally up when at least one of the member ports is up and that port's status is channeling. The port channel is operationally down when all member ports are operationally down.

Port-Channel Interfaces

The following shows port-channel interfaces.

Figure 1: Port-Channel Interfaces

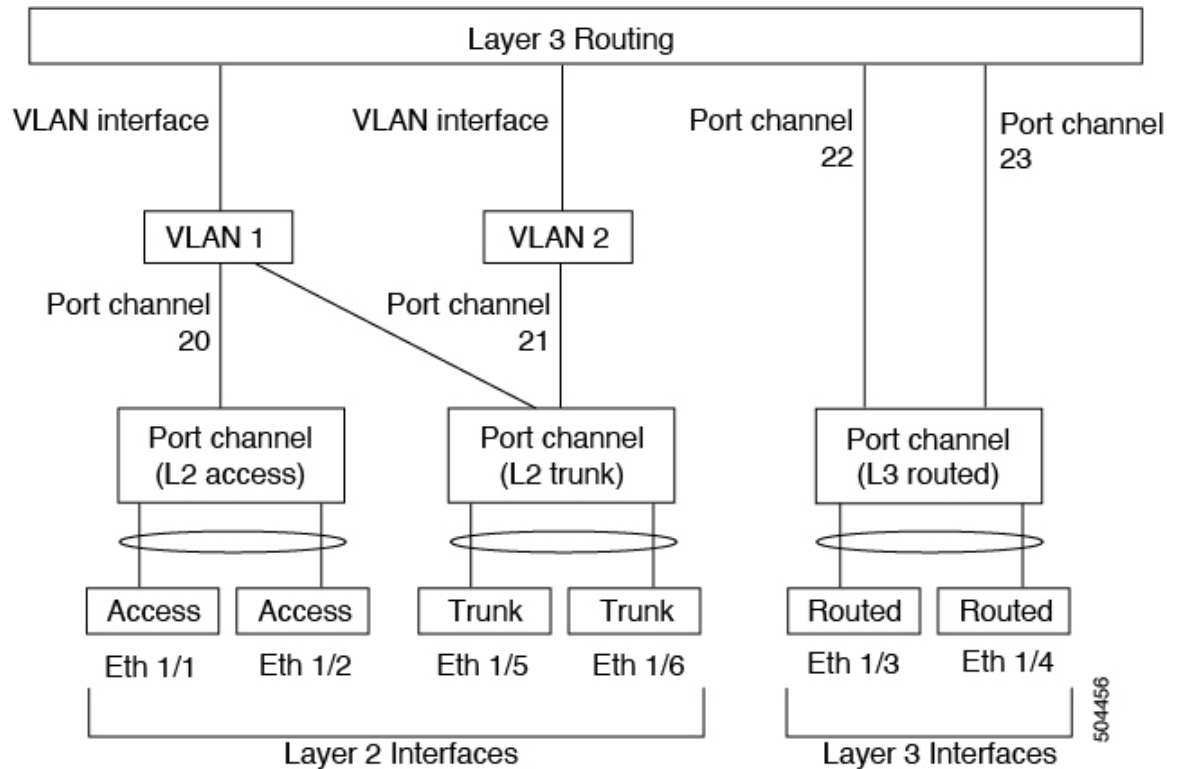

You can classify port-channel interfaces as Layer 2 or Layer 3 interfaces. In addition, you can configure Layer 2 port channels in either access or trunk mode. Layer 3 port-channel interfaces have routed ports as channel members.

You can configure a Layer 3 port channel with a static MAC address. If you do not configure this value, the Layer 3 port channel uses the router MAC of the first channel member to come up. See the *Cisco Nexus® 3550-T Layer 2 Switching Configuration* section for information about configuring static MAC addresses on Layer 3 port channels.

See the *Configuring Layer 2 Interfaces* chapter for information about configuring Layer 2 ports in access or trunk mode and the *Configuring Layer 3 Interfaces* chapter for information about configuring Layer 3 interfaces.

Basic Settings

You can configure the following basic settings for the port-channel interface:

- Bandwidth—Use this setting for informational purposes only; this setting is to be used by higher-level protocols.
- Delay—Use this setting for informational purposes only; this setting is to be used by higher-level protocols.
- Description
- Duplex
- IP addresses

- Shutdown
- Speed

Compatibility Requirements

When you add an interface to a channel group, the software checks certain interface attributes to ensure that the interface is compatible with the channel group. For example, you cannot add a Layer 3 interface to a Layer 2 channel group. The Cisco NX-OS software also checks a number of operational attributes for an interface before allowing that interface to participate in the port-channel aggregation.

The compatibility check includes the following operational attributes:

- Network layer
- (Link) speed capability
- Speed configuration
- Duplex capability
- Duplex configuration
- Port mode
- Access VLAN
- Trunk native VLAN
- Tagged or untagged
- Allowed VLAN list
- Flow-control capability
- Flow-control configuration
- Media type, either copper or fiber

Use the **show port-channel compatibility-parameters** command to see the full list of compatibility checks that the Cisco NX-OS uses.

You can only add interfaces configured with the channel mode set to on to static port channels, and you can only add interfaces configured with the channel mode as active or passive to port channels that are running LACP. You can configure these attributes on an individual member port. If you configure a member port with an incompatible attribute, the software suspends that port in the port channel.

Alternatively, you can force ports with incompatible parameters to join the port channel if the following parameters are the same:

- (Link) speed capability
- Speed configuration
- Duplex capability
- Duplex configuration

- Flow-control capability
- Flow-control configuration

When the interface joins a port channel, some of its individual parameters are removed and replaced with the values on the port channel as follows:

- Bandwidth
- Delay
- Extended Authentication Protocol over UDP
- VRF
- IP address
- MAC address
- Spanning Tree Protocol

Many interface parameters remain unaffected when the interface joins or leaves a port channel as follows:

- Beacon
- Description
- CDP
- LACP port priority
- Debounce
- UDLD
- MDIX
- Rate mode
- Shutdown
- SNMP trap



Note When you delete the port channel, the software sets all member interfaces as if they were removed from the port channel.

Load Balancing Using Port Channels

The Cisco NX-OS software load balances traffic across all operational interfaces in a port channel by hashing the addresses in the frame to a numerical value that selects one of the links in the channel. Port channels provide load balancing by default. Port-channel load balancing uses MAC addresses, IP addresses, or Layer 4 port numbers to select the link. Port-channel load balancing uses either source or destination addresses or ports, or both source and destination addresses or ports.

You can configure the load-balancing mode to apply to all port channels that are configured on the entire device. You can configure one load-balancing mode for the entire device. You cannot configure the load-balancing method per port channel.

You can configure the type of load-balancing algorithm used. You can choose the load-balancing algorithm that determines which member port to select for egress traffic by looking at the fields in the frame.

The default load-balancing mode for Layer 3 interfaces is the source and destination IP L4 ports, and the default load-balancing mode for non-IP traffic is the source and destination MAC address. Use the **port-channel load-balance** command to set the load-balancing method among the interfaces in the channel-group bundle. The default method for Layer 2 packets is src-dst-mac. The default method for Layer 3 packets is src-dst IP.

You can configure the device to use one of the following methods to load balance across the port channel:

- Destination IP address
- Source IP address
- Source and destination IP address
- Source MAC address
- Destination MAC address
- Source and destination MAC address

Non-IP and Layer 3 port channels both follow the configured load-balancing method, using the source, destination, or source and destination parameters. For example, when you configure load balancing to use the source IP address, all non-IP traffic uses the source MAC address to load balance the traffic while the Layer 3 traffic load balances the traffic using the source IP address. Similarly, when you configure the destination MAC address as the load-balancing method, all Layer 3 traffic uses the destination IP address while the non-IP traffic load balances using the destination MAC address.

The unicast and multicast traffic is load-balanced across port-channel links based on configured load-balancing algorithm displayed in **show port-channel load-balancing** command output.

The multicast traffic uses the following methods for load balancing with port channels:

- Multicast traffic with Layer 4 information—Source IP address, source port, destination IP address, destination port
- Multicast traffic without Layer 4 information—Source IP address, destination IP address
- Non-IP multicast traffic—Source MAC address, destination MAC address



Note Devices that run Cisco IOS can optimize the behavior of the member ports ASICs if a failure of a single member occurred by running the port-channel hash-distribution command. The Cisco Nexus 3550-T device performs this optimization by default and does not require or support this command. Cisco NX-OS does support the customization of the load-balancing criteria on port channels through the port-channel load-balance command for the entire device.

LACP

LACP allows you to configure up to 4 interfaces into a port channel.

LACP Overview

The Link Aggregation Control Protocol (LACP) for Ethernet is defined in IEEE 802.1AX and IEEE 802.3ad. This protocol controls how physical ports are bundled together to form one logical channel.



Note You must enable LACP before you can use LACP. By default, LACP is disabled. See the *Enabling LACP* section for information about enabling LACP.

The system automatically takes a checkpoint before disabling the feature, and you can roll back to this checkpoint. See the *Cisco Nexus® 3550-T System Management Configuration* section for information about rollbacks and checkpoints.

Individual links can be combined into LACP port channels and channel groups as well as function as individual links.

With LACP, you can bundle up to 4 interfaces in a channel group.



Note When you delete the port channel, the software automatically deletes the associated channel group. All member interfaces revert to their original configuration.

You cannot disable LACP while any LACP configurations are present.

Port-Channel Modes

Individual interfaces in port channels are configured with channel modes. When you run static port channels with no aggregation protocol, the channel mode is always set to **on**. After you enable LACP globally on the device, you enable LACP for each channel by setting the channel mode for each interface to either **active** or **passive**. You can configure channel mode for individual links in the LACP channel group when you are adding the links to the channel group



Note You must enable LACP globally before you can configure an interface in either the **active** or **passive** channel mode.

The following table describes the channel modes.

Table 2: Channel Modes for Individual Links in a Port Channel

Channel Mode	Description
passive	The LACP is enabled on this port channel and the ports are in a passive negotiating state. Ports responds to LACP packets that it receives but does not initiate LACP negotiation.
active	The LACP is enabled on this port channel and the ports are in an active negotiating state. Ports initiate negotiations with other ports by sending LACP packets.
on	The LACP is disabled on this port channel and the ports are in a non-negotiating state. The on state of the port channel represents the static mode. The port will not verify or negotiate port channel memberships. If you attempt to change the channel mode to active or passive before enabling LACP, the device displays an error message. When an LACP attempts to negotiate with an interface in the on state, it does not receive any LACP packets and becomes an individual link with that interface, it does not join the LACP channel group. The on state is the default port-channel mode

Both the passive and active modes allow LACP to negotiate between ports to determine if they can form a port channel based on criteria such as the port speed and the trunking state. The passive mode is useful when you do not know whether the remote system, or partner, supports LACP.

Two devices can form an LACP port channel when their ports are in different LACP modes if the modes are compatible as in the following example:

Table 3: Channel Modes Compatibility

Device 1 > Port-1	Device 2 > Port-2	Result
Active	Active	Can form a port channel.
Active	Passive	Can form a port channel.
Passive	Passive	Cannot form a port channel because no ports can initiate negotiation.
On	Active	Cannot form a port channel because LACP is enabled only on one side.
On	Passive	Cannot form a port channel because LACP is not enabled.

LACP ID Parameters

This section describes the LACP parameters.

LACP System Priority

Each system that runs LACP has an LACP system priority value. You can accept the default value of 32768 for this parameter, or you can configure a value between 1 and 65535. LACP uses the system priority with the MAC address to form the system ID and also uses the system priority during negotiation with other devices. A higher system priority value means a lower priority.



Note The LACP system ID is the combination of the LACP system priority value and the MAC address.

LACP Port Priority

Each port that is configured to use LACP has an LACP port priority. You can accept the default value of 32768 for the LACP port priority, or you can configure a value between 1 and 65535. LACP uses the port priority with the port number to form the port identifier.

LACP uses the port priority to decide which ports should be put in standby mode when there is a limitation that prevents all compatible ports from aggregating and which ports should be put into active mode. A higher port priority value means a lower priority for LACP. You can configure the port priority so that specified ports have a lower priority for LACP and are most likely to be chosen as active links, rather than hot-standby links.

LACP Administrative Key

LACP automatically configures an administrative key value equal to the channel-group number on each port configured to use LACP. The administrative key defines the ability of a port to aggregate with other ports. A port's ability to aggregate with other ports is determined by these factors:

- Port physical characteristics, such as the data rate and the duplex capability
- Configuration restrictions that you establish

LACP-Enabled and Static Port Channels Differences

The following table summarizes the major differences between port channels with LACP enabled and static port channels.

Table 4: Port Channels with LACP Enabled and Static Port Channels

Configurations	Port Channels with LACP Enabled	Static Port Channels
Protocol applied	Enable globally	Not applicable
Channel mode of links	Can be either: <ul style="list-style-type: none"> • Active • Passive 	Can only be On

Configurations	Port Channels with LACP Enabled	Static Port Channels
Maximum number of links in channel	4	4

LACP Compatibility Enhancements

When a Cisco Nexus 3550-T device is connected to a non-Nexus peer, its graceful failover defaults may delay the time that is taken to bring down a disabled port or cause traffic from the peer to be lost. To address these conditions, the **lACP graceful-convergence** command was added.

By default, LACP sets a port to suspended state if it does not receive an LACP PDU from the peer. **lACP suspend-individual** is a default configuration on Cisco Nexus® 3550-T switches. This command puts the port in suspended state if it does not receive any LACP PDUs. In some cases, although this feature helps in preventing loops created due to misconfigurations, it can cause servers fail to boot up because they require LACP to logically bring up the port. You can put a port into an individual state by using the **no lACP suspend-individual**. Port in individual state takes attributes of the individual port based on the port configuration.

LACP port-channels exchange LACP PDUs for quick bundling of links when connecting a server and a switch. However, the links go into suspended state when the PDUs are not received.

The **delayed LACP** feature enables one port-channel member, the delayed-LACP port, to come up first as a member of a regular port-channel before LACP PDUs are received. After it is connected in LACP mode, other members, the auxiliary LACP ports, are brought up. This avoids having the links becoming suspended when PDUs are not received.

Which port in the port-channel comes up first depends on the port-priority value of the ports. A member link in a port channel with lowest priority value, will come up first as a LACP delayed port. Regardless of the operational status of the links, the configured priority of a LACP port is used to select the delayed-lacp port

This feature supports Layer 2 port channels and trunk mode spanning tree and has the following limitations:

- Using **no lACP suspend-individual** and **lACP mode delay** on a same port channel is not recommended because it can put non-lacp delayed ports in individual state. As a best practice, you must avoid combining these two configurations.
- Not supported on Layer 3 port channels.

LACP Port-Channel Minimum Links and MaxBundle

A port channel aggregates similar ports to provide increased bandwidth in a single manageable interface.

The introduction of the minimum links and maxbundle feature further refines LACP port-channel operation and provides increased bandwidth in one manageable interface.

The LACP port-channel minimum links feature does the following:

- Configures the minimum number of ports that must be linked up and bundled in the LACP port channel.
- Prevents the low-bandwidth LACP port channel from becoming active.
- Causes the LACP port channel to become inactive if there are few active members ports to supply the required minimum bandwidth.

The LACP MaxBundle defines the maximum number of bundled ports allowed in a LACP port channel.

The LACP MaxBundle feature does the following:

- Defines an upper limit on the number of bundled ports in an LACP port channel.
- Allows hot-standby ports with fewer bundled ports. (For example, in an LACP port channel with five ports, you can designate two of those ports as hot-standby ports.)



Note The minimum links and maxbundle feature works only with LACP port channels. However, the device allows you to configure this feature in non-LACP port channels, but the feature is not operational.

LACP Fast Timers

You can change the LACP timer rate to modify the duration of the LACP timeout. Use the `lACP rate` command to set the rate at which LACP control packets are sent to an LACP-supported interface. You can change the timeout rate from the default rate (30 seconds) to the fast rate (1 second). This command is supported only on LACP-enabled interfaces. To configure the LACP fast time rate, see the *Configuring the LACP Fast Timer Rate* section.

Prerequisites for Port Channeling

Port channeling has the following prerequisites:

- You must be logged onto the device.
- All ports for a single port channel must be either Layer 2 or Layer 3 ports.
- All ports for a single port channel must meet the compatibility requirements. See the [Compatibility Requirements, on page 5](#) section for more information about the compatibility requirements.

Guidelines and Limitations

Port channeling has the following configuration guidelines and limitations:

- **show** commands with the **internal** keyword are not supported.
- The LACP port-channel minimum links and maxbundle feature is not supported for host interface port channels.
- Enable LACP before you can use that feature.
- You can configure multiple port channels on a device.
- Do not put shared and dedicated ports into the same port channel. (See the *Configuring Basic Interface Parameters* chapter for information about shared and dedicated ports.)

- For Layer 2 port channels, ports with different STP port path costs can form a port channel if they are compatibly configured with each other. See the [Compatibility Requirements, on page 5](#) section for more information about the compatibility requirements.
-
- In STP, the port-channel cost is based on the aggregated bandwidth of the port members.
- After you configure a port channel, the configuration that you apply to the port channel interface affects the port channel member ports. The configuration that you apply to the member ports affects only the member port where you apply the configuration.
- LACP does not support half-duplex mode. Half-duplex ports in LACP port channels are put in the suspended state.
- A maximum of 24 port channels can be supported by Cisco Nexus 3550-T switches system-wide.
- A maximum of 12 port channels can be supported by Cisco Nexus 3550-T switches system-wide.
- On a Cisco Nexus 3550-T switch, 8 ports are part of the same port group. All the ports in the same port group must have same speed. Maximum of eight member ports per port-channel. All the member ports must be in the same port group.
Only four port channels per port group is supported.
- On a Cisco Nexus 3550-T switch, 4 ports are part of the same quadrant. All the ports in the same quadrant must have same speed. Maximum of four member ports per port-channel. All the member ports must be in the same quad.
Only one port channel per quad is supported.

Default Settings

The following table lists the default settings for port-channel parameters.

Table 5: Default Port-Channel Parameters

Parameters	Default
Port channel	Admin up
Load balancing method for Layer 3 interfaces	Source and destination IP address
Load balancing method for Layer 2 interfaces	Source and destination MAC address
Load balancing per module	Disabled
LACP	Disabled
Channel mode	on
LACP system priority	32768
LACP port priority	32768
Minimum links for LACP	1

Parameters	Default
Maxbundle	8
Maxbundle	4

Configuring Port Channels



Note See the *Configuring Layer 3 Interfaces* chapter for information about configuring IPv4 addresses on the port-channel interface.



Note If you are familiar with the Cisco IOS CLI, be aware that the Cisco NX-OS commands for this feature might differ from the Cisco IOS commands that you would use.

Creating a Port Channel

You can create a port channel before you create a channel group. The software automatically creates the associated channel group.



Note When the port channel is created before the channel group, the port channel should be configured with all of the interface attributes that the member interfaces are configured with. Use the **switchport mode trunk** {*allowed vlan vlan-id* | *native vlan-id*} command to configure the members.

This is required only when the channel group members are Layer 2 ports (switchport) and trunks (switchport mode trunk).



Note Use the **no interface port-channel** command to remove the port channel and delete the associated channel group.

Command	Purpose
no interface port-channel <i>channel-number</i> Example: switch(config)# no interface port-channel 1	Removes the port channel and deletes the associated channel group.

Before you begin

Enable LACP if you want LACP-based port channels.

Procedure

	Command or Action	Purpose
Step 1	configure terminal Example: switch# configure terminal switch(config)#	Enters global configuration mode.
Step 2	interface port-channel <i>channel-number</i> Example: switch(config)# interface port-channel 1 switch(config-if)	Specifies the port-channel interface to configure, and enters the interface configuration mode. The range is from 1 to 4096. The Cisco NX-OS software automatically creates the channel group if it does not already exist.
Step 3	show port-channel summary Example: switch(config-router)# show port-channel summary	(Optional) Displays information about the port channel.
Step 4	no shutdown Example: switch# configure terminal switch(config)# int e1/1 switch(config-if)# no shutdown	(Optional) Clears the errors on the interfaces and VLANs where policies correspond with hardware policies. This command allows policy programming to continue and the port to come up. If policies do not correspond, the errors are placed in an error-disabled policy state.
Step 5	copy running-config startup-config Example: switch(config)# copy running-config startup-config	(Optional) Copies the running configuration to the startup configuration.

Example

This example shows how to create a port channel:

```
switch# configure terminal
switch (config)# interface port-channel 1
```

See the [Compatibility Requirements, on page 5](#) section for details on how the interface configuration changes when you delete the port channel.

Adding a Layer 2 Port to a Port Channel

You can add a Layer 2 port to a new channel group or to a channel group that already contains Layer 2 ports. The software creates the port channel associated with this channel group if the port channel does not already exist.



Note Use the **no channel-group** command to remove the port from the channel group.

Command	Purpose
no channel-group Example: <pre>switch(config)# no channel-group</pre>	Removes the port from the channel group.

Before you begin

Enable LACP if you want LACP-based port channels.

All Layer 2 member ports must run in full-duplex mode and at the same speed

Procedure

	Command or Action	Purpose
Step 1	configure terminal Example: <pre>switch# configure terminal switch(config)#</pre>	Enters global configuration mode.
Step 2	interface type slot/port Example: <pre>switch(config)# interface ethernet 1/4 switch(config-if)#</pre>	Specifies the interface that you want to add to a channel group, and enters the interface configuration mode.
Step 3	switchport Example: <pre>switch(config)# switchport</pre>	Configures the interface as a Layer 2 access port.
Step 4	switchport mode trunk Example: <pre>switch(config)# switchport mode trunk</pre>	(Optional) Configures the interface as a Layer 2 trunk port.
Step 5	switchport trunk {allowed vlan <i>vlan-id</i> native <i>vlan-id</i>} Example: <pre>switch(config)# switchport trunk native 3 switch(config-if)#</pre>	(Optional) Configures necessary parameters for a Layer 2 trunk port.
Step 6	channel-group <i>channel-number</i>[force] [mode {on active passive}] Example:	Configures the port in a channel group and sets the mode. The channel-number range is from 1 to 4096. This command creates the port channel associated with this channel group if the port

	Command or Action	Purpose
	<ul style="list-style-type: none"> • <code>switch(config-if)# channel-group 5</code> • <code>switch(config-if)# channel-group 5 force</code> 	<p>channel does not already exist. All static port-channel interfaces are set to mode on. You must set all LACP-enabled port-channel interfaces to active or passive. The default mode is on.</p> <p>(Optional) Forces an interface with some incompatible configurations to join the channel. The forced interface must have the same speed, duplex, and flow control settings as the channel group.</p>
Step 7	<p><code>show interface type slot/port</code></p> <p>Example:</p> <pre>switch# show interface port channel 5</pre>	(Optional) Displays interface information.
Step 8	<p><code>no shutdown</code></p> <p>Example:</p> <pre>switch# configure terminal switch(config)# int e1/4 switch(config-if)# no shutdown</pre>	(Optional) Clears the errors on the interfaces and VLANs where policies correspond with hardware policies. This command allows policy programming to continue and the port to come up. If policies do not correspond, the errors are placed in an error-disabled policy state.
Step 9	<p><code>copy running-config startup-config</code></p> <p>Example:</p> <pre>switch(config)# copy running-config startup-config</pre>	(Optional) Copies the running configuration to the startup configuration.

Example

This example shows how to add a Layer 2 Ethernet interface 1/4 to channel group 5:

```
switch# configure terminal
switch (config)# interface ethernet 1/4
switch(config-if)# switchport
switch(config-if)# channel-group 5
```

Adding a Layer 3 Port to a Port Channel

You can add a Layer 3 port to a new channel group or to a channel group that is already configured with Layer 3 ports. The software creates the port channel associated with this channel group if the port channel does not already exist.

If the Layer 3 port that you are adding has a configured IP address, the system removes that IP address before adding the port to the port channel. After you create a Layer 3 port channel, you can assign an IP address to the port-channel interface.



Note Use the **no channel-group** command to remove the port from the channel group. The port reverts to its original configuration. You must reconfigure the IP addresses for this port.

Command	Purpose
no channel-group Example: <pre>switch(config)# no channel-group</pre>	Removes the port from the channel group.

Before you begin

Enable LACP if you want LACP-based port channels.

Remove any IP addresses configured on the Layer 3 interface.

Procedure

	Command or Action	Purpose
Step 1	configure terminal Example: <pre>switch# configure terminal switch(config)#</pre>	Enters global configuration mode.
Step 2	interface type slot/port Example: <pre>switch(config)# interface ethernet 1/4 switch(config-if)#</pre>	Specifies the interface that you want to add to a channel group, and enters the interface configuration mode.
Step 3	no switchport Example: <pre>switch(config-if)# no switchport</pre>	Configures the interface as a Layer 3 port.
Step 4	channel-group channel-number [force] [mode {on active passive}] Example: <ul style="list-style-type: none"> • <pre>switch(config-if)# channel-group 5</pre> • <pre>switch(config-if)# channel-group 5 force</pre> 	Configures the port in a channel group and sets the mode. The channel-number range is from 1 to 4096. The Cisco NX-OS software creates the port channel associated with this channel group if the port channel does not already exist. (Optional) Forces an interface with some incompatible configurations to join the channel. The forced interface must have the same speed, duplex, and flow control settings as the channel group.
Step 5	show interface type slot/port Example:	(Optional) Displays interface information.

	Command or Action	Purpose
	<code>switch# show interface ethernet 1/4</code>	
Step 6	no shutdown Example: <code>switch# configure terminal</code> <code>switch(config)# int e1/1</code> <code>switch(config-if)# no shutdown</code>	(Optional) Clears the errors on the interfaces and VLANs where policies correspond with hardware policies. This command allows policy programming to continue and the port to come up. If policies do not correspond, the errors are placed in an error-disabled policy state.
Step 7	copy running-config startup-config Example: <code>switch(config)# copy running-config startup-config</code>	(Optional) Copies the running configuration to the startup configuration.

Example

This example shows how to add a Layer 3 Ethernet interface 1/5 to channel group 6 in on mode:

```
switch# configure terminal
switch (config)# interface ethernet 1/5
switch(config-if)# switchport
switch(config-if)# channel-group 6
```

This example shows how to create a Layer 3 port-channel interface and assign the IP address:

```
switch# configure terminal
switch (config)# interface port-channel 4
switch(config-if)# ip address 192.0.2.1/8
```

Configuring the Bandwidth and Delay for Informational Purposes

The bandwidth of the port channel is determined by the number of total active links in the channel.

You configure the bandwidth and delay on port-channel interfaces for informational purposes.

Procedure

	Command or Action	Purpose
Step 1	configure terminal Example: <code>switch# configure terminal</code> <code>switch(config)#</code>	Enters global configuration mode.

	Command or Action	Purpose
Step 2	interface port-channel <i>channel-number</i> Example: switch(config)# interface port-channel 2 switch(config-if)#	Specifies the port-channel interface that you want to configure, and enters the interface mode.
Step 3	bandwidth <i>value</i> Example: switch(config-if)# bandwidth 60000000 switch(config-if)#	Specifies the bandwidth, which is used for informational purposes. The range is from 1 to 3,200,000,000 kbs. The default value depends on the total active interfaces in the channel group.
Step 4	delay <i>value</i> Example: switch(config-if)# delay 10000 switch(config-if)#	Specifies the throughput delay, which is used for informational purposes. The range is from 1 to 16,777,215 tens of microseconds. The default value is 10 microseconds.
Step 5	exit Example: switch(config-if)# exit switch(config)#	Exits the interface mode and returns to the configuration mode.
Step 6	show interface port-channel <i>channel-number</i> Example: switch# show interface port-channel 2	(Optional) Displays interface information for the specified port channel.
Step 7	copy running-config startup-config Example: switch(config)# copy running-config startup-config	(Optional) Copies the running configuration to the startup configuration.

Example

This example shows how to configure the informational parameters of the bandwidth and delay for port channel 5:

```
switch# configure terminal
switch (config)# interface port-channel 5
switch(config-if)# bandwidth 60000000
switch(config-if)# delay 10000
switch(config-if)#
```

Shutting Down and Restarting the Port-Channel Interface

You can shut down and restart the port-channel interface. When you shut down a port-channel interface, no traffic passes and the interface is administratively down.

Procedure

	Command or Action	Purpose
Step 1	configure terminal Example: switch# configure terminal switch(config)#	Enters global configuration mode.
Step 2	interface port-channel <i>channel-number</i> Example: switch(config)# interface port-channel 2 switch(config-if)#	Specifies the port-channel interface that you want to configure, and enters the interface mode.
Step 3	shutdown Example: switch(config-if)# shutdown switch(config-if)#	Shuts down the interface. No traffic passes and the interface displays as administratively down. The default is no shutdown. Note Use the no shutdown command to open the interface. The interface displays as administratively up. If there are no operational problems, traffic passes. The default is no shutdown.
Step 4	exit Example: switch(config-if)# exit switch(config)#	Exits the interface mode and returns to the configuration mode.
Step 5	show interface port-channel <i>channel-number</i> Example: switch(config-router)# show interface port-channel 2	(Optional) Displays interface information for the specified port channel.
Step 6	no shutdown Example: switch# configure terminal switch(config)# int e1/4 switch(config-if)# no shutdown	(Optional) Clears the errors on the interfaces and VLANs where policies correspond with hardware policies. This command allows policy programming to continue and the port to come up. If policies do not correspond, the errors are placed in an error-disabled policy state.
Step 7	copy running-config startup-config Example: switch(config)# copy running-config startup-config	(Optional) Copies the running configuration to the startup configuration.

Example

This example shows how to bring up the interface for port channel 2:

```
switch# configure terminal
switch (config)# interface port-channel 2
switch(config-if)# no shutdown
```

Configuring a Port-Channel Description

You can configure a description for a port channel.

Procedure

	Command or Action	Purpose
Step 1	configure terminal Example: switch# configure terminal switch(config)#	Enters global configuration mode.
Step 2	interface port-channel <i>channel-number</i> Example: switch(config)# interface port-channel 2 switch(config-if)#	Specifies the port-channel interface that you want to configure, and enters the interface mode.
Step 3	description Example: switch(config-if)# description engineering switch(config-if)#	Allows you to add a description to the port-channel interface. You can use up to 80 characters in the description. By default, the description does not display; you must configure this parameter before the description displays in the output.
Step 4	exit Example: switch(config-if)# exit switch(config)#	Exits the interface mode and returns to the configuration mode.
Step 5	show interface port-channel <i>channel-number</i> Example: switch# show interface port-channel 2	(Optional) Displays interface information for the specified port channel.
Step 6	copy running-config startup-config Example: switch(config)# copy running-config startup-config	(Optional) Copies the running configuration to the startup configuration.

Example

This example shows how to add a description to port channel 2:

```
switch# configure terminal
switch (config)# interface port-channel 2
switch(config-if)# description engineering
```

Enabling LACP

LACP is disabled by default; you must enable LACP before you begin LACP configuration. You cannot disable LACP while any LACP configuration is present.

LACP learns the capabilities of LAN port groups dynamically and informs the other LAN ports. Once LACP identifies correctly matched Ethernet links, it group the links into a port channel. The port channel is then added to the spanning tree as a single bridge port.

To configure LACP, you must do the following:

- Enable LACP globally by using the **feature lacp** command.
- You can use different modes for different interfaces within the same LACP-enabled port channel. You can change the mode between **active** and **passive** for an interface only if it is the only interface that is designated to the specified channel group.

Procedure

	Command or Action	Purpose
Step 1	configure terminal Example: switch# configure terminal switch(config)#	Enters global configuration mode.
Step 2	feature lacp Example: switch(config)# feature lacp	Enables LACP on the device.
Step 3	copy running-config startup-config Example: switch(config)# copy running-config startup-config	(Optional) Copies the running configuration to the startup configuration.

Example

This example shows how to enable LACP:

```
switch# configure terminal
switch (config)# feature lacp
```

Configuring LACP Port-Channel Port Modes

After you enable LACP, you can configure the channel mode for each individual link in the LACP port channel as **active** or **passive**. This channel configuration mode allows the link to operate with LACP.

When you configure port channels with no associated aggregation protocol, all interfaces on both sides of the link remain in the **on** channel mode.

Procedure

	Command or Action	Purpose
Step 1	configure terminal Example: switch# configure terminal switch(config)#	Enters global configuration mode.
Step 2	interface type slot/port Example: switch(config)# interface ethernet 1/4 switch(config-if)#	Specifies the interface that you want to add to a channel group, and enters the interface configuration mode.
Step 3	channel-group number mode {active on passive} Example: switch(config-if)# channel-group 5 mode active	Specifies the port mode for the link in a port channel. After LACP is enabled, you configure each link or the entire channel as active or passive. When you run port channels with no associated aggregation protocol, the port-channel mode is always on. The default port-channel mode is on .
Step 4	show port-channel summary Example: switch(config-if)# show port-channel summary	(Optional) Displays summary information about the port channels.
Step 5	copy running-config startup-config Example: switch(config)# copy running-config startup-config	(Optional) Copies the running configuration to the startup configuration.

Example

This example shows how to set the LACP-enabled interface to the active port-channel mode for Ethernet interface 1/4 in channel group 5:

```
switch# configure terminal
switch (config)# interface ethernet 1/4
switch(config-if)# channel-group 5 mode active
```

Configuring LACP Port-Channel Minimum Links

You can configure the LACP minimum links feature. Although minimum links and maxbundles work only in LACP, you can enter the CLI commands for these features for non-LACP port channels, but these commands are nonoperational.



Note Use the **no lacp min-links** command to restore the default port-channel minimum links configuration.

Command	Purpose
no lacp min-links Example: switch(config)# no lacp min-links	Restores the default port-channel minimum links configuration.

Before you begin

Ensure that you are in the correct port-channel interface.

Procedure

	Command or Action	Purpose
Step 1	configure terminal Example: switch# configure terminal switch(config)#	Enters global configuration mode.
Step 2	interface port-channel <i>number</i> Example: switch(config)# interface port-channel 3 switch(config-if)#	Specifies the interface to configure, and enters the interface configuration mode.
Step 3	lacp min-links <i>number</i> Example: switch(config-if)# lacp min-links 3	Specifies the port-channel interface to configure the number of minimum links. The range is from 1 to 4.
Step 4	show running-config interface port-channel <i>number</i> Example: switch(config-if)# show running-config interface port-channel 3	(Optional) Displays the port-channel minimum links configuration.

Example

This example shows how to configure the minimum number of port-channel member interfaces to be up/active for the port-channel to be up/active:

```
switch# configure terminal
switch(config)# interface port-channel 3
switch(config-if)# lacp min-links 3
```

Configuring the LACP Port-Channel MaxBundle

You can configure the LACP maxbundle feature. Although minimum links and maxbundles work only in LACP, you can enter the CLI commands for these features for non-LACP port channels, but these commands are nonoperational.



Note Use the **no lacp max-bundle** command to restore the default port-channel max-bundle configuration.

Command	Purpose
no lacp max-bundle Example: <pre>switch(config)# no lacp max-bundle</pre>	Restores the default port-channel max-bundle configuration.

Before you begin

Ensure that you are in the correct port-channel interface.

Procedure

	Command or Action	Purpose
Step 1	configure terminal Example: <pre>switch# configure terminal switch(config)#</pre>	Enters global configuration mode.
Step 2	interface port-channel <i>number</i> Example: <pre>switch(config)# interface port-channel 3 switch(config-if)#</pre>	Specifies the interface to configure, and enters the interface configuration mode.
Step 3	lacp max-bundle <i>number</i> Example:	Specifies the port-channel interface to configure max-bundle.

	Command or Action	Purpose
	<code>switch(config-if)# lacp max-bundle</code>	<p>The default value for the port-channel max-bundle is 8. The allowed range is from 1 to 8.</p> <p>The default value for the port-channel max-bundle is 4. The allowed range is from 1 to 4.</p> <p>Note Even if the default value is 8, the number of active members in a port channel is the minimum of the <code>pc_max_links_config</code> and <code>pc_max_active_members</code> that is allowed in the port channel.</p> <p>Even if the default value is 4, the number of active members in a port channel is the minimum of the <code>pc_max_links_config</code> and <code>pc_max_active_members</code> that is allowed in the port channel.</p>
Step 4	<p>show running-config interface port-channel number</p> <p>Example:</p> <pre>switch(config-if)# show running-config interface port-channel 3</pre>	(Optional) Displays the port-channel max-bundle configuration.

Example

This example shows how to configure the port channel interface max-bundle:

```
switch# configure terminal
switch(config)# interface port-channel 3
switch(config-if)# lacp max-bundle 3
```

Configuring the LACP Fast Timer Rate

You can change the LACP timer rate to modify the duration of the LACP timeout. Use the **lacp rate** command to set the rate at which LACP control packets are sent to an LACP-supported interface. You can change the timeout rate from the default rate (30 seconds) to the fast rate (1 second). This command is supported only on LACP-enabled interfaces.



Note We do not recommend changing the LACP timer rate. HA and SSO are not supported when the LACP fast rate timer is configured.

Before you begin

Ensure that you have enabled the LACP feature.

Procedure

	Command or Action	Purpose
Step 1	configure terminal Example: <pre>switch# configure terminal switch(config)#</pre>	Enters global configuration mode.
Step 2	interface type slot/port Example: <pre>switch(config)# interface ethernet 1/4 switch(config-if)#</pre>	Specifies the interface to configure and enters the interface configuration mode.
Step 3	lacp rate fast Example: <pre>switch(config-if)# lacp rate fast</pre>	Configures the fast rate (one second) at which LACP control packets are sent to an LACP-supported interface. To reset the timeout rate to its default, use the no form of the command.

Example

This example shows how to configure the LACP fast rate on Ethernet interface 1/4:

```
switch# configure terminal
switch (config)# interface ethernet 1/4
switch(config-if)# lacp rate fast
```

This example shows how to restore the LACP default rate (30 seconds) on Ethernet interface 1/4.

```
switch# configure terminal
switch (config)# interface ethernet 1/4
switch(config-if)# no lacp rate fast
```

Configuring the LACP System Priority

The LACP system ID is the combination of the LACP system priority value and the MAC address.

Before you begin

Enable LACP.

Procedure

	Command or Action	Purpose
Step 1	configure terminal Example: switch# configure terminal switch(config)#	Enters global configuration mode.
Step 2	lacp system-priority <i>priority</i> Example: switch(config)# lacp system-priority 40000	Configures the system priority for use with LACP. Valid values are from 1 through 65535, and higher numbers have a lower priority. The default value is 32768.
Step 3	show lacp system-identifier Example: switch(config-if)# show lacp system-identifier	(Optional) Displays the LACP system identifier.
Step 4	copy running-config startup-config Example: switch(config)# copy running-config startup-config	(Optional) Copies the running configuration to the startup configuration.

Example

This example shows how to set the LACP system priority to 2500:

```
switch# configure terminal
switch(config)# lacp system-priority 2500
```

Configuring the LACP Port Priority

When you enable LACP, you can configure each link in the LACP port channel for the port priority.

Before you begin

Enable LACP.

Procedure

	Command or Action	Purpose
Step 1	configure terminal Example: switch# configure terminal switch(config)#	Enters global configuration mode.

	Command or Action	Purpose
Step 2	interface <i>type slot/port</i> Example: switch(config)# interface ethernet 1/4 switch(config-if)#	Specifies the interface that you want to add to a channel group, and enters the interface configuration mode.
Step 3	lacp port-priority <i>priority</i> Example: switch(config-if)# lacp port-priority 40000	Configures the port priority for use with LACP. Valid values are from 1 through 65535, and higher numbers have a lower priority. The default value is 32768.
Step 4	copy running-config startup-config Example: switch(config-if)# copy running-config startup-config	(Optional) Copies the running configuration to the startup configuration.

Example

This example shows how to set the LACP port priority for Ethernet interface 1/4 to 40000:

```
switch# configure terminal
switch (config)# interface ethernet 1/4
switch(config-if)# lacp port-priority 40000
```

Configuring LACP System MAC and Role

You can configure the MAC address used by the LACP for protocol exchanges and the optional role. By default, the role is primary.

This procedure is supported on the Cisco Nexus 3550-T switches.

Before you begin

LACP must be enabled.

Procedure

	Command or Action	Purpose
Step 1	configure terminal Example: switch# configure terminal	Enter global configuration mode.
Step 2	lacp system-mac <i>mac-address</i> role <i>role-value</i> Example: switch(config)# lacp system-mac 000a.000b.000c role primary	Specifies the MAC address to use in the LACP protocol exchanges. The role is optional. Primary is the default.

	Command or Action	Purpose
	<code>switch(config)# lacp system-mac 000a.000b.000c role secondary</code>	
Step 3	(Optional) show lacp system-identifier Example: <code>switch(config)# show lacp system-identifier</code>	Displays the configured MAC address.
Step 4	copy running-config startup-config Example: <code>switch(config)# copy running-config startup-config</code>	Copies the running configuration to the startup configuration.

Example

The following example shows how to configure the role of a switch as primary.

```
Switch1# sh lacp system-identifier
32768,0-b-0-b-0-b
Switch1# sh run | grep lacp
feature lacp
lacp system-mac 000b.000b.000b role primary
```

The following example shows how to configure the role of a switch as secondary.

```
Switch2# sh lacp system-identifier
32768,0-b-0-b-0-b
Switch2# sh run | grep lacp
feature lacp
lacp system-mac 000b.000b.000b role secondary
```

Disabling LACP Graceful Convergence

By default, LACP graceful convergence is enabled. In situations where you need to support LACP interoperability with devices where the graceful failover defaults may delay the time taken for a disabled port to be brought down or cause traffic from the peer to be lost, you can disable convergence. If the downstream access switch is not a Cisco Nexus device, disable the LACP graceful convergence option.



Note The port channel has to be in the administratively down state before the command can be run.

Before you begin

Enable LACP.

Procedure

	Command or Action	Purpose
Step 1	configure terminal Example: switch# configure terminal switch(config)#	Enters global configuration mode.
Step 2	interface port-channel <i>number</i> Example: switch(config)# interface port-channel 1 switch(config-if)#	Specifies the port channel interface to configure and enters the interface configuration mode.
Step 3	shutdown Example: switch(config-if) shutdown	Administratively shuts down the port channel.
Step 4	no lacp graceful-convergence Example: switch(config-if)# no lacp graceful-convergence	Disables LACP graceful convergence on the port channel.
Step 5	no shutdown Example: switch(config-if) no shutdown	Brings the port channel administratively up.
Step 6	copy running-config startup-config Example: switch(config)# copy running-config startup-config	(Optional) Copies the running configuration to the startup configuration.

Example

This example shows how to disable LACP graceful convergence on a port channel:

```
switch# configure terminal
switch (config)# interface port-channel 1
switch(config-if)# shutdown
switch(config-if)# no lacp graceful-convergence
switch(config-if)# no shutdown
```

Reenabling LACP Graceful Convergence

If the default LACP graceful convergence is once again required, you can reenabling convergence.

Procedure

	Command or Action	Purpose
Step 1	configure terminal Example: switch# configure terminal switch(config)#	Enters global configuration mode.
Step 2	interface port-channel <i>number</i> Example: switch(config)# interface port-channel 1 switch(config-if)#	Specifies the port channel interface to configure and enters the interface configuration mode.
Step 3	shutdown Example: switch(config-if) shutdown	Administratively shuts down the port channel.
Step 4	lACP graceful-convergence Example: switch(config-if)# lACP graceful-convergence	Enables LACP graceful convergence on the port channel.
Step 5	no shutdown Example: switch(config-if) no shutdown	Brings the port channel administratively up.
Step 6	copy running-config startup-config Example: switch(config)# copy running-config startup-config	(Optional) Copies the running configuration to the startup configuration.

Example

This example shows how to enable LACP graceful convergence on a port channel:

```
switch# configure terminal
switch (config)# interface port-channel 1
switch(config-if)# shutdown
switch(config-if)# lACP graceful-convergence
switch(config-if)# no shutdown
```

Disabling LACP Suspend Individual

LACP sets a port to the suspended state if it does not receive an LACP PDU from the peer. This process can cause some servers to fail to boot up as they require LACP to logically bring up the port.



Note You should only enter the **lACP suspend-individual** command on edge ports. The port channel has to be in the administratively down state before you can use this command.

Before you begin

Enable LACP.

Procedure

	Command or Action	Purpose
Step 1	configure terminal Example: switch# configure terminal switch(config)#	Enters global configuration mode.
Step 2	interface port-channel <i>number</i> Example: switch(config)# interface port-channel 1 switch(config-if)#	Specifies the port channel interface to configure and enters the interface configuration mode.
Step 3	shutdown Example: switch(config-if) shutdown	Administratively shuts down the port channel.
Step 4	no lACP suspend-individual Example: switch(config-if)# no lACP suspend-individual	Disables LACP individual port suspension behavior on the port channel.
Step 5	no shutdown Example: switch(config-if) no shutdown	Brings the port channel administratively up.
Step 6	copy running-config startup-config Example: switch(config)# copy running-config startup-config	(Optional) Copies the running configuration to the startup configuration.

Example

This example shows how to disable LACP individual port suspension on a port channel:

```
switch# configure terminal
switch (config)# interface port-channel 1
```

```
switch(config-if)# shutdown
switch(config-if)# no lACP suspend-individual
switch(config-if)# no shutdown
```

Reenabling LACP Suspend Individual

You can reenble the default LACP individual port suspension.

Procedure

	Command or Action	Purpose
Step 1	configure terminal Example: switch# configure terminal switch(config)#	Enters global configuration mode.
Step 2	interface port-channel <i>number</i> Example: switch(config)# interface port-channel 1 switch(config-if)#	Specifies the port channel interface to configure and enters the interface configuration mode.
Step 3	shutdown Example: switch(config-if) shutdown	Administratively shuts down the port channel.
Step 4	lACP suspend-individual Example: switch(config-if)# lACP suspend-individual	Enables LACP individual port suspension behavior on the port channel.
Step 5	no shutdown Example: switch(config-if) no shutdown	Brings the port channel administratively up.
Step 6	copy running-config startup-config Example: switch(config)# copy running-config startup-config	(Optional) Copies the running configuration to the startup configuration.

Example

This example shows how to reenble the LACP individual port suspension on a port channel:

```
switch# configure terminal
switch (config)# interface port-channel 1
switch(config-if)# shutdown
```

```
switch(config-if)# lacp suspend-individual
switch(config-if)# no shutdown
```

Configuring Delayed LACP

The delayed LACP feature enables one port channel member, the delayed LACP port, to come up first as a member of a regular port channel before LACP PDUs are received. You configure the delayed LACP feature using the **lacp mode delay** command on a port channel followed by configuring the LACP port priority on a one member port of the port channel.

Procedure

	Command or Action	Purpose
Step 1	configure terminal	Enters global configuration mode.
Step 2	interface port-channel <i>number</i>	Specifies the port channel interface to configure and enters the interface configuration mode.
Step 3	lacp mode delay	<p>Enables delayed LACP.</p> <p>Note To disable delayed LACP, use the no lacp mode delay command.</p> <p>Complete the configuration of the delayed LACP by configuring the LACP port priority. See the "Configuring the LACP Port Priority" section for details.</p> <p>The priority of a LACP port determines the election of the delayed LACP port. The port with the lowest numerical priority is elected.</p> <p>When the delayed LACP feature is configured and made effective with a port channel flap, the delayed LACP port operates as a member of a regular port channel, allowing data to be exchanged between the server and switch. After receiving the first LACP PDU, the delayed LACP port transitions from a regular port member to a LACP port member.</p> <p>Note The election of the delayed LACP port is not complete or effective until the port channel flaps on the switch or at a remote server.</p>

Example

The following example configures delayed LACP.

```
switch# config terminal
switch(config)# interface po 1
switch(config-if)# lacp mode delay
```

```
switch# config terminal
switch(config)# interface ethernet 1/1
switch(config-if)# lacp port-priority 1
switch(config-if)# channel-group 1 mode active
```

The following example disables delayed LACP.

```
switch# config terminal
switch(config)# interface po 1
switch(config-if)# no lacp mode delay
```

Verifying the Port-Channel Configuration

To display port-channel configuration information, perform one of the following tasks:

Command	Purpose
show interface port-channel <i>channel-number</i>	Displays the status of a port-channel interface.
show feature	Displays enabled features.
load- interval { <i>interval seconds</i> { 1 2 3 }}	Sets three different sampling intervals to bit-rate and packet-rate statistics.
show port-channel compatibility-parameters	Displays the parameters that must be the same among the member ports in order to join a port channel.
show port-channel database [interface port-channel <i>channel-number</i>]	Displays the aggregation state for one or more port-channel interfaces.
show port-channel load-balance	Displays the type of load balancing in use for port channels.
show port-channel summary	Displays a summary for the port-channel interfaces.
show port-channel traffic	Displays the traffic statistics for port channels.
show port-channel usage	Displays the range of used and unused channel numbers.
show lacp { counters [interface port-channel <i>channel-number</i>] [interface type/slot] neighbor [interface port-channel <i>channel-number</i>] port-channel [interface port-channel <i>channel-number</i>] system-identifier]}}	Displays information about LACP.
show running-config interface port-channel <i>channel-number</i>	Displays information about the running configuration of the port-channel.

Monitoring the Port-Channel Interface Configuration

Use the following commands to display port-channel interface configuration information.

Command	Purpose
clear counters interface port-channel <i>channel-number</i>	Clears the counters.
clear lacp counters [interface port-channel <i>channel-number</i>]	Clears the LACP counters.
load- interval { interval seconds { 1 2 3 }}	Sets three different sampling intervals to bit-rate and packet-rate statistics.
show interface counters [module <i>module</i>]	Displays input and output octets unicast packets, multicast packets, and broadcast packets.
show interface counters detailed [all]	Displays input packets, bytes, and multicast and output packets and bytes. Note Ignore <i>Output Dropped Errors</i> as it represents the cumulative ingress drops in the traffic that is directed to the port. The ingress drops on any port are displayed as part of <i>Input Discard Errors</i> .
show interface counters errors [module <i>module</i>]	Displays information about the number of error packets. Note Ignore <i>OutDiscards</i> as it represents the cumulative ingress drops in the traffic that is directed to the port. The ingress drops on any port are displayed as part of <i>InDiscards</i> .
show lacp counters	Displays statistics for LACP.

Example Configurations for Port Channels

This example shows how to create an LACP port channel and add two Layer 2 interfaces to that port channel:

```
switch# configure terminal
switch (config)# feature lacp
switch (config)# interface port-channel 5
switch (config-if)# interface ethernet 1/4
switch (config-if)# switchport
switch (config-if)# channel-group 5 mode active
switch (config-if)# lacp port priority 40000
switch (config-if)# interface ethernet 1/7
switch (config-if)# switchport
switch (config-if)# channel-group 5 mode
```

This example shows how to add two Layer 3 interfaces to a channel group. The Cisco NX-OS software automatically creates the port channel:

```
switch# configure terminal
switch (config)# interface ethernet 1/5
switch(config-if)# no switchport
switch(config-if)# no ip address
switch(config-if)# channel-group 6 mode active
switch (config)# interface ethernet 1/6
switch(config-if)# no switchport
switch(config-if)# no ip address
switch(config-if)# channel-group 6 mode active
switch (config)# interface port-channel 6
switch(config-if)# ip address 192.0.2.1/8
```

Related Documents

Related Topic	Document Title
System management	<i>Cisco Nexus 3550-T NX-OS System Management Configuration</i> section
Licensing	<i>Cisco NX-OS Licensing Guide</i>

