

FC Analyzer and SPAN for MDS Switches Configuration Example

Document ID: 46220

Contents

Introduction

Prerequisites

- Requirements
- Components Used
- Conventions

Background Theory

Configure

- Configuring Local FC Analyzer
- Configuring for Remote FC Analyzer
- Configuring for Local SPAN
- Configuring for Remote SPAN
- Notes for Port Analyzer Adapter Devices

Verify

Troubleshoot

Related Information

Introduction

Similar to the Cisco router product line s debug capability, the Cisco MDS storage switches have a Fibre Channel (FC) analyzer to examine packets. The FC analyzer examines packets to and from the entities that the switch provides. The FC analyzer is able to debug frames that the switch is responsible for receiving or sending to a storage device. Frames between end stations can not be examined by the FC analyzer.

To examine session flow, the Switched Port Analyzer (SPAN) functionality of the MDS switches should be used. Much like the SPAN function on a Cisco Ethernet switch, SPAN on the MDS product line replicates data to SPAN destination ports, so that it can be collected by a third-party device.

Prerequisites

Requirements

There are no specific requirements for this document.

Components Used

The information in this document is based on these software and hardware versions:

- Cisco MDS 9216 Switch
- Cisco MDS 9509 Switch
- Both run Storage Area Networking Operating System (SAN-OS) 1.2.1a.

The information in this document was created from the devices in a specific lab environment. All of the devices used in this document started with a cleared (default) configuration. If your network is live, make sure that you understand the potential impact of any command.

Conventions

For more information on document conventions, refer to the Cisco Technical Tips Conventions.

Background Theory

You must know when to use the FC analyzer tool and when to use the SPAN feature.

The FC analyzer is a tool that collects frames that are destined to or originate from the MDS supervisor. Node-to-switch or switch-to-switch traffic can be seen with this tool.

The SPAN is a feature that allows frames that are transient to the switch to be copied to a second port for analysis. Node-to-node traffic can be seen with this method.

Refer to this diagram for an illustration:

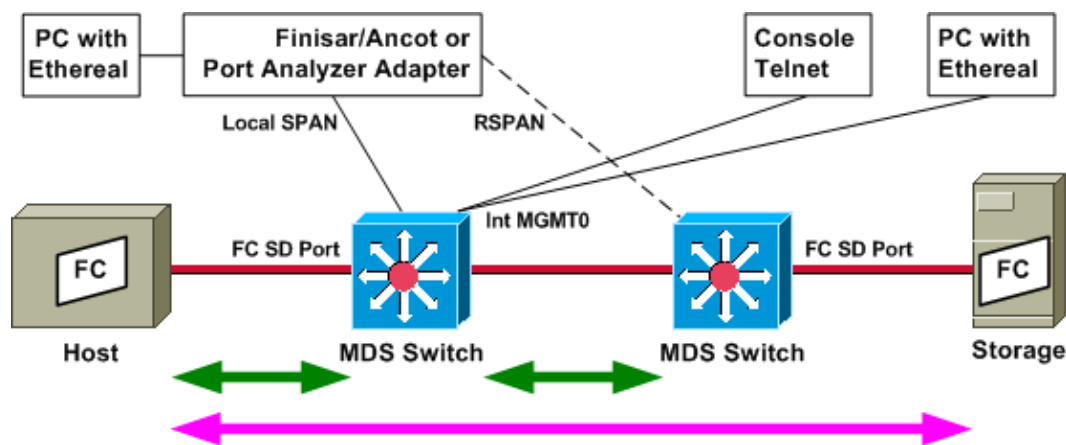

The green arrows show traffic that can be traced with the FC analyzer tool, while the pink arrow shows traffic that can be captured with the SPAN method. Traffic from the host to the storage can not be observed by the FC analyzer. Only traffic from the host to the switch or from the switch on the right can be seen, when you run the FC analyzer on the switch on the left.

SPAN can be used to trace traffic in (ingress) and out (egress) of any port on the switch. Remote SPAN (RSPAN), as shown in the previous diagram, can be used to collect frames in and out of the host port on the left switch, with the analyzer attached to the right side switch.

Configure

In this section, you are presented with the information to configure the features described in this document.

Note: To find additional information on the commands used in this document, use the Command Lookup Tool (registered customers only) .

Configuring Local FC Analyzer

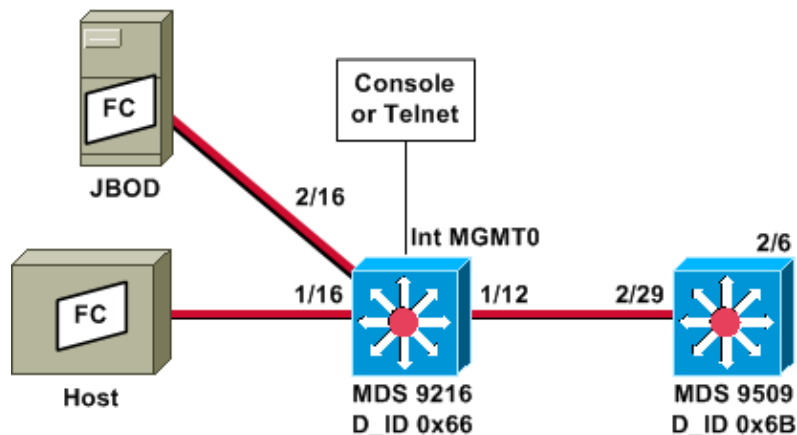

Note: The intent is to collect FC frames that originate from, or are destined to, the 9612 supervisor. Frames from the host to JBOD are *not* collected with the FC analyzer tool.

FC analyzer local is run from the command-line interface (CLI) via console attachment or Telnet. You may run a brief display to show only a small portion of each frame, or you may run a detailed trace to show the entire frame.

The trace is started while in configuration mode, and it is stopped when you press **Ctrl-C**. By default, only 100 frames are captured. To capture more than 100 frames, add the **limit-captured-frames** command option to the command that you use to start the trace.

You may also use a display filter to limit the output of the trace to only specific frames.

!--- VSAN 13 (0xd) is used here as example.

```
MDS9216# show fcdomain domain-list vsan 13
```

```
Number of domains: 2
```

```
Domain ID          WWN
-----
0x66(102)         20:0d:00:05:30:00:47:9f [Local] [Principal]
0x6b(107)         20:0d:00:05:30:00:51:1f
```

```
MDS9216# show fcns data vsan 13
```

```
VSAN 13:
```

```
-----
FCID          TYPE  PWWN                               (VENDOR)          FC4-TYPE:FEATURE
-----
0x6600dc     NL    21:00:00:20:37:15:a2:49 (Seagate)         scsi-fcp:target
0x6600e0     NL    21:00:00:04:cf:6e:4a:8c (Seagate)         scsi-fcp:target
0x6600e1     NL    21:00:00:04:cf:6e:37:8b (Seagate)         scsi-fcp:target
0x660101     NL    10:00:00:01:73:00:81:82 (JNI)              scsi-fcp:target
0x660201     N     10:00:00:05:30:00:47:9f (Cisco)             ipfc
0x6b0001     N     10:00:00:05:30:00:51:23 (Cisco)             ipfc
```

```
Total number of entries = 6
```

!--- Configure FC analyzer for brief output.

```
MDS9216# config t
```

```
Enter configuration commands, one per line. End with CNTL/Z.
```

```
MDS9216(config)# fcanalyzer local brief display-filter mdshdr.vsan==0xd
```

```

Capturing on eth2
 0.000000 ff.ff.fd -> ff.ff.fd SW_ILS HLO
 0.000095 ff.ff.fd -> ff.ff.fd FC Link Ctl, ACK1
18.721559 ff.ff.fd -> ff.ff.fd SW_ILS HLO
18.721879 ff.ff.fd -> ff.ff.fd FC Link Ctl, ACK1
19.970287 ff.ff.fd -> ff.ff.fd SW_ILS HLO
19.970368 ff.ff.fd -> ff.ff.fd FC Link Ctl, ACK1
38.941558 ff.ff.fd -> ff.ff.fd SW_ILS HLO
38.941849 ff.ff.fd -> ff.ff.fd FC Link Ctl, ACK1
39.940546 ff.ff.fd -> ff.ff.fd SW_ILS HLO
39.940628 ff.ff.fd -> ff.ff.fd FC Link Ctl, ACK1

```

In the next example, you have the same data. This time, however, the **brief** option is omitted from the command, to provide a detailed view of each packet.

```
MDS9216(config)# fcanalyzer local display-filter mdshdr.vsan==0xd
```

```

Capturing on eth2
Frame 1 (100 bytes on wire, 100 bytes captured)
  Arrival Time: Jul  4, 2003 12:31:18.310251000
  Time delta from previous packet: 0.000000000 seconds
  Time relative to first packet: 0.000000000 seconds
  Frame Number: 1
  Packet Length: 100 bytes
  Capture Length: 100 bytes
Ethernet II, Src: 00:00:00:00:00:0a, Dst: 00:00:00:00:ee:00
  Destination: 00:00:00:00:ee:00 (00:00:00:00:ee:00)
  Source: 00:00:00:00:00:0a (00:00:00:00:00:0a)
  Type: Unknown (0xfcfc)
Vegas (FC, SOFf/EOFn)
  Vegas Header
    .000 .... = Version: 0
    .... 0000 = Andiamo Type: Normal FC frame (0)
    #MPLS Labels: 0
    Packet Len: 70
    TTL: 255
    0111 .... = User Priority: 7
    .... 0000 0010 11.. = Dst Index: 0x000b
    .... ..00 1111 1111 = Src Index: 0x00ff
    Ctrl Bits: Index Directed frame (0x01)
    Timestamp: 42678
    .... .000 = Status: 0 (0)
    0000 0... = Reason Code: 0 (0x00)
    .... 0000 0000 1101 = VSAN: 13
    Checksum: 0
  Vegas Trailer
    EOF: EOFn (3)
    CRC: 4022250974
Fibre Channel
  R_CTL: 0x02
  Dest Addr: ff.ff.fd
  CS_CTL: 0x00
  Src Addr: ff.ff.fd
  Type: SW_ILS (0x22)
  F_CTL: 0x380000 (Exchange Originator, Seq Initiator, Exchg First,
    Exchg Last, Seq Last, CS_CTL, Last Data Frame - No Info,
    ABTS - Abort/MS, )
  SEQ_ID: 0xe7
  DF_CTL: 0x00
  SEQ_CNT: 0
  OX_ID: 0xleb4
  RX_ID: 0xffff
  Parameter: 0x00000000
SW_ILS
  Cmd Code: HLO (0x14)

```

FSPF Header
Version: 0x02
AR Number: 0x00
Authentication Type: 0x00
Originating Domain ID: 102
Authentication: 0000000000000000
Options: 00000000
Hello Interval (secs): 20
Dead Interval (secs): 80
Recipient Domain ID: 107
Originating Port Idx: 0x01000b

Frame 2 (60 bytes on wire, 60 bytes captured)
Arrival Time: Jul 4, 2003 12:31:18.310563000
Time delta from previous packet: 0.000312000 seconds
Time relative to first packet: 0.000312000 seconds
Frame Number: 2
Packet Length: 60 bytes
Capture Length: 60 bytes
Ethernet II, Src: 00:00:00:00:00:00, Dst: 00:00:00:00:00:00
Destination: 00:00:00:00:00:00 (00:00:00:00:00:00)
Source: 00:00:00:00:00:00 (00:00:00:00:00:00)
Type: Unknown (0x0000)
Vegas (FC, SOFf/EOft)

Vegas Header
.000 = Version: 0
.... 0000 = Andiamo Type: Normal FC frame (0)
#MPLS Labels: 0
Packet Len: 30
TTL: 255
0111 = User Priority: 7
.... 0011 1111 11.. = Dst Index: 0x00ff
.... ..00 0000 1011 = Src Index: 0x000b
Ctrl Bits: 0 (0x00)
Timestamp: 42679
.... .000 = Status: 0 (0)
0000 0... = Reason Code: 0 (0x00)
.... 0000 0000 1101 = VSAN: 13
Checksum: 241
Vegas Trailer
EOF: EOft (1)
CRC: 1019832848

Fibre Channel
R_CTL: 0xc0(ACK1)
Dest Addr: ff.ff.fd
CS_CTL: 0x00
Src Addr: ff.ff.fd
Type: Unknown (0x00)
F_CTL: 0xf80000 (Exchange Responder, Seq Recipient, Exchg First,
Exchg Last, Seq Last, CS_CTL, Last Data Frame - No Info,
ABTS - Cont,)
SEQ_ID: 0xe7
DF_CTL: 0x00
SEQ_CNT: 0
OX_ID: 0x1eb4
RX_ID: 0x1e66
Parameter: 0x00000001

Frame 3 (100 bytes on wire, 100 bytes captured)
Arrival Time: Jul 4, 2003 12:31:19.309559000
Time delta from previous packet: 0.998996000 seconds
Time relative to first packet: 0.999308000 seconds
Frame Number: 3
Packet Length: 100 bytes
Capture Length: 100 bytes
Ethernet II, Src: 00:00:00:00:00:00, Dst: 00:00:00:00:00:00

```

Destination: 00:00:00:00:00:00 (00:00:00:00:00:00)
Source: 00:00:00:00:00:00 (00:00:00:00:00:00)
Type: Unknown (0x0000)
Vegas (FC, SOFf/EOFn)
  Vegas Header
    .000 .... = Version: 0
    .... 0000 = Andiamo Type: Normal FC frame (0)
    #MPLS Labels: 0
    Packet Len: 70
    TTL: 255
    0111 .... = User Priority: 7
    .... 0011 1111 11.. = Dst Index: 0x00ff
    .... ..00 0000 1011 = Src Index: 0x000b
    Ctrl Bits: 0 (0x00)
    Timestamp: 42779
    .... .000 = Status: 0 (0)
    0000 0... = Reason Code: 0 (0x00)
    .... 0000 0000 1101 = VSAN: 13
    Checksum: 101
  Vegas Trailer
    EOF: EOFn (3)
    CRC: 4200187557
Fibre Channel
  R_CTL: 0x02
  Dest Addr: ff.ff.fd
  CS_CTL: 0x00
  Src Addr: ff.ff.fd
  Type: SW_ILS (0x22)
  F_CTL: 0x380000 (Exchange Originator, Seq Initiator, Exchg First,
                  Exchg Last, Seq Last, CS_CTL, Last Data Frame - No Info,
                  ABTS - Abort/MS, )

  SEQ_ID: 0xe7
  DF_CTL: 0x00
  SEQ_CNT: 0
  OX_ID: 0x1e67
  RX_ID: 0xffff
  Parameter: 0x00000000
SW_ILS
  Cmd Code: HLO (0x14)
  FSPF Header
    Version: 0x02
    AR Number: 0x00
    Authentication Type: 0x00
    Originating Domain ID: 107
    Authentication: 0000000000000000
  Options: 00000000
  Hello Interval (secs): 20
  Dead Interval (secs): 80
  Recipient Domain ID: 102
  Originating Port Idx: 0x01011c

Frame 4 (60 bytes on wire, 60 bytes captured)
  Arrival Time: Jul  4, 2003 12:31:19.309646000
  Time delta from previous packet: 0.000087000 seconds
  Time relative to first packet: 0.999395000 seconds
  Frame Number: 4
  Packet Length: 60 bytes
  Capture Length: 60 bytes
Ethernet II, Src: 00:00:00:00:00:0a, Dst: 00:00:00:00:ee:00
  Destination: 00:00:00:00:ee:00 (00:00:00:00:ee:00)
  Source: 00:00:00:00:00:0a (00:00:00:00:00:0a)
  Type: Unknown (0xfcfc)
Vegas (FC, SOFf/EOFt)
  Vegas Header
    .000 .... = Version: 0
    .... 0000 = Andiamo Type: Normal FC frame (0)

```

```

#MPLS Labels: 0
Packet Len: 30
TTL: 255
0111 .... = User Priority: 7
.... 0000 0010 11.. = Dst Index: 0x000b
.... ..00 1111 1111 = Src Index: 0x00ff
Ctrl Bits: Index Directed frame (0x01)
Timestamp: 42778
.... .000 = Status: 0 (0)
0000 0... = Reason Code: 0 (0x00)
.... 0000 0000 1101 = VSAN: 13
Checksum: 0
Vegas Trailer
EOF: EOFt (1)
CRC: 4022250974
Fibre Channel
R_CTL: 0xc0(ACK1)
Dest Addr: ff.ff.fd
CS_CTL: 0x00
Src Addr: ff.ff.fd
Type: Unknown (0x00)
F_CTL: 0xf80000 (Exchange Responder, Seq Recipient, Exchg First,
                Exchg Last, Seq Last, CS_CTL, Last Data Frame - No Info,
                ABTS - Cont, )

SEQ_ID: 0xe7
DF_CTL: 0x00
SEQ_CNT: 0
OX_ID: 0x1e67
RX_ID: 0x1eb5
Parameter: 0x00000001

```

Again, the brief trace is shown. This time, however, the PC on port 1/16 is unplugged and re-plugged to force a log in. You see frames to and from the other FC switch, and to and from the attached local node (the PC).

```
MDS9216(config)# fcanalyzer local brief display-filter mdshdr.vsan==0xd
```

```
Capturing on eth2
```

```

0.000000 ff.ff.fd -> ff.ff.fd SW_ILS HLO
0.000310 ff.ff.fd -> ff.ff.fd FC Link Ctl, ACK1
0.999598 ff.ff.fd -> ff.ff.fd SW_ILS HLO
0.999684 ff.ff.fd -> ff.ff.fd FC Link Ctl, ACK1
19.990040 ff.ff.fd -> ff.ff.fd SW_ILS HLO
19.990295 ff.ff.fd -> ff.ff.fd FC Link Ctl, ACK1
20.990602 ff.ff.fd -> ff.ff.fd SW_ILS HLO
20.990682 ff.ff.fd -> ff.ff.fd FC Link Ctl, ACK1
26.028780 ff.fc.66 -> ff.fc.6b SW_ILS SW_RSCN
26.029087 ff.fc.66 -> ff.fc.66 FC Link Ctl, ACK1
26.029541 ff.fc.66 -> ff.fc.66 SW_ILS SW_ACC (SW_RSCN)
26.029596 ff.fc.66 -> ff.fc.66 FC Link Ctl, ACK1
31.151197 00.00.01 -> ff.ff.fe FC ELS FLOGI
31.162809 ff.ff.fe -> 66.01.01 FC ELS ACC (FLOGI)
31.162841 ff.ff.fe -> 66.01.01 FC ELS ACC (FLOGI)
31.163139 66.01.01 -> ff.ff.fd FC ELS SCR
31.163583 ff.ff.fd -> 66.01.01 FC ELS ACC (SCR)
31.163603 ff.ff.fd -> 66.01.01 FC ELS ACC (SCR)
31.163835 66.01.01 -> ff.ff.fc FC ELS PLOGI
31.163965 ff.ff.fc -> 66.01.01 FC ELS ACC (PLOGI)
31.163985 ff.ff.fc -> 66.01.01 FC ELS ACC (PLOGI)
31.164186 66.01.01 -> ff.ff.fc dNS GA_NXT
31.164305 ff.fc.66 -> ff.fc.6b SW_ILS SW_RSCN
31.164479 ff.fc.66 -> ff.fc.66 FC Link Ctl, ACK1
31.164628 ff.fc.66 -> ff.fc.66 SW_ILS SW_ACC (SW_RSCN)
31.164670 ff.fc.66 -> ff.fc.66 FC Link Ctl, ACK1
31.165030 ff.ff.fc -> 66.01.01 dNS ACC (GA_NXT)
31.165050 ff.ff.fc -> 66.01.01 dNS ACC (GA_NXT)

```

31.165125	ff.fc.6b -> ff.fc.66	dns GE_ID
31.165193	ff.fc.66 -> ff.fc.6b	FC Link Ctl, ACK1
31.165419	66.01.01 -> ff.ff.fc	dns GA_NXT
31.165577	ff.fc.66 -> ff.fc.6b	dns ACC (GE_ID)
31.165781	ff.ff.fc -> 66.01.01	dns ACC (GA_NXT)
31.165804	ff.ff.fc -> 66.01.01	dns ACC (GA_NXT)
31.165943	ff.fc.6b -> ff.fc.66	FC Link Ctl, ACK1
31.166063	66.01.01 -> ff.ff.fc	dns GA_NXT
31.166870	ff.ff.fc -> 66.01.01	dns ACC (GA_NXT)
31.166892	ff.ff.fc -> 66.01.01	dns ACC (GA_NXT)
31.167268	66.01.01 -> ff.ff.fc	dns GA_NXT
31.167529	ff.ff.fc -> 66.01.01	dns ACC (GA_NXT)
31.167549	ff.ff.fc -> 66.01.01	dns ACC (GA_NXT)
31.168704	66.01.01 -> ff.ff.fc	dns GA_NXT
31.169272	ff.ff.fc -> 66.01.01	dns ACC (GA_NXT)
31.169294	ff.ff.fc -> 66.01.01	dns ACC (GA_NXT)
31.169568	66.01.01 -> ff.ff.fc	dns GA_NXT
31.170453	ff.ff.fc -> 66.01.01	dns ACC (GA_NXT)
31.170473	ff.ff.fc -> 66.01.01	dns ACC (GA_NXT)
31.170756	66.01.01 -> ff.ff.fc	dns GA_NXT
31.170975	ff.ff.fc -> 66.01.01	dns ACC (GA_NXT)
31.170994	ff.ff.fc -> 66.01.01	dns ACC (GA_NXT)
31.171400	66.01.01 -> 66.02.01	FC ELS PLOGI
31.171562	66.02.01 -> 66.01.01	FC ELS ACC (PLOGI)
31.171581	66.02.01 -> 66.01.01	FC ELS ACC (PLOGI)
31.171752	66.01.01 -> 66.02.01	FC ELS PRLI
31.171812	66.02.01 -> 66.01.01	FC ELS LS_RJT (PRLI)
31.171832	66.02.01 -> 66.01.01	FC ELS LS_RJT (PRLI)
31.173863	66.01.01 -> ff.ff.fc	FC ELS LOGO
31.175020	ff.ff.fc -> 66.01.01	FC ELS ACC (LOGO)
31.175047	ff.ff.fc -> 66.01.01	FC ELS ACC (LOGO)
31.175182	66.01.01 -> ff.ff.fc	FC ELS PLOGI
31.175290	ff.ff.fc -> 66.01.01	FC ELS ACC (PLOGI)
31.175310	ff.ff.fc -> 66.01.01	FC ELS ACC (PLOGI)
31.175632	66.01.01 -> ff.ff.fa	FC ELS PLOGI
31.175753	ff.ff.fa -> 66.01.01	FC ELS ACC (PLOGI)
31.175777	ff.ff.fa -> 66.01.01	FC ELS ACC (PLOGI)
32.460020	ff.fc.66 -> 66.01.01	FC ELS PLOGI
32.460050	ff.fc.66 -> 66.01.01	FC ELS PLOGI
32.460207	66.01.01 -> ff.fc.66	FC ELS ACC (PLOGI)
32.460246	66.01.01 -> ff.fc.66	FC ELS ACC (PLOGI)
32.460340	ff.fc.66 -> 66.01.01	FC ELS PRLI
32.460362	ff.fc.66 -> 66.01.01	FC ELS PRLI
32.460492	66.01.01 -> ff.fc.66	FC ELS LS_RJT (PRLI)
32.460525	66.01.01 -> ff.fc.66	FC ELS LS_RJT (PRLI)
32.461839	ff.fc.66 -> 66.01.01	FC ELS LOGO
32.461866	ff.fc.66 -> 66.01.01	FC ELS LOGO
32.462046	66.01.01 -> ff.fc.66	FC ELS ACC (LOGO)
32.462080	66.01.01 -> ff.fc.66	FC ELS ACC (LOGO)

MDS9216(config)# ^C

MDS9216(config)# exit

Configuring for Remote FC Analyzer

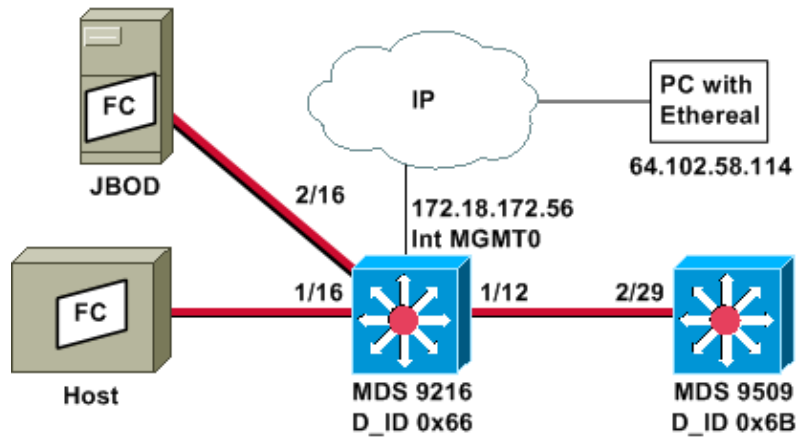

Note: The intent is to collect FC frames that originate from, or are destined to, the 9612 supervisor. Frames from the host to JBOD are *not* collected with the FC analyzer tool.

FC analyzer remote is run on a PC that is using Ethereal [0.9\(9\)](#) or later and WinPcap [0.9\(9\)](#). The IP address of the PC is specified in the command that is issued to start the FC analyzer trace on the MDS CLI. On the PC, Ethereal must also be started from the command line, and the IP address of the MDS management interface must be specified in the command.

1. To stop the MDS FC analyzer trace, you must press **Ctrl-C** from the CLI.

```
MDS9216# config t
Enter configuration commands, one per line. End with CNTL/Z.
MDS9216(config)# fcalyzer remote 64.102.58.114
MDS9216(config)# ^C
```

Do not specify the **active** option on the previous command, or you will need to add additional options to the command line on your PC when you start Ethereal. Adding the **active** keyword usually means that you have to also configure the TCP port number. It is recommended that you use the defaults.

2. On the PC, verify the IP address, and start the Ethereal remote capture program.

```
d:\> ipconfig
Windows 2000 IP Configuration

Ethernet adapter wireless:

    Connection-specific DNS Suffix  . : cisco.com
    IP Address. . . . . : 64.102.58.114
    Subnet Mask . . . . . : 255.255.255.128
    Default Gateway . . . . . : 64.102.58.1

Ethernet adapter builtinE:

    Connection-specific DNS Suffix  . : cisco.com
    Autoconfiguration IP Address. . . : 169.254.219.141
    Subnet Mask . . . . . : 255.255.0.0
    Default Gateway . . . . . :

d:\> cd ethereal099

D:\Ethereal099> ethereal099 -i rpcap://172.18.172.56/eth2
```

3. Once the program starts, choose **Capture** and then click **OK** to initiate packet collection.

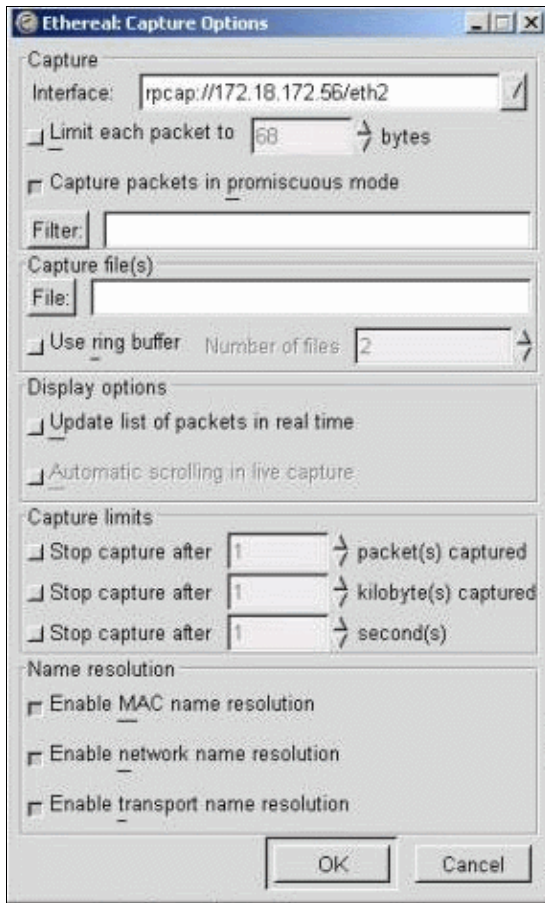

The FC packets that are collected appear as Other in the summary display.

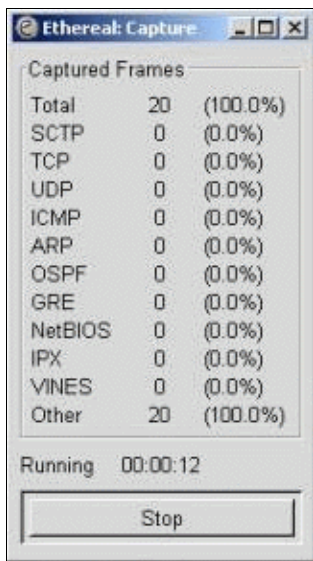

4. Click **Stop** to halt packet collection and start the trace view portion of the program.

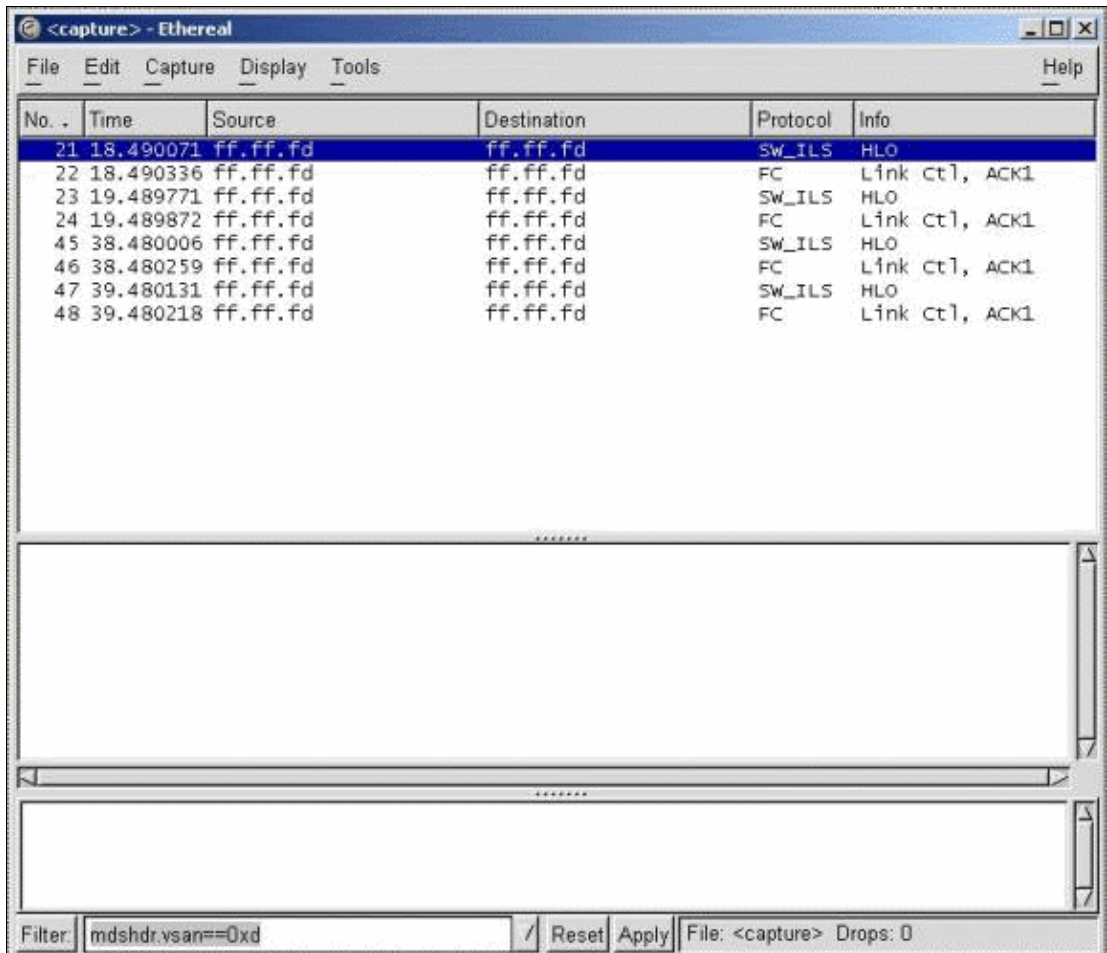

You may use filters to limit the display to a specific traffic stream.

5. If there is problem with the remote capture initiation, you may see an error screen similar to the one in the next image. The FC analyzer is not active on the MDS, or the **active** keyword was used without a specified port.

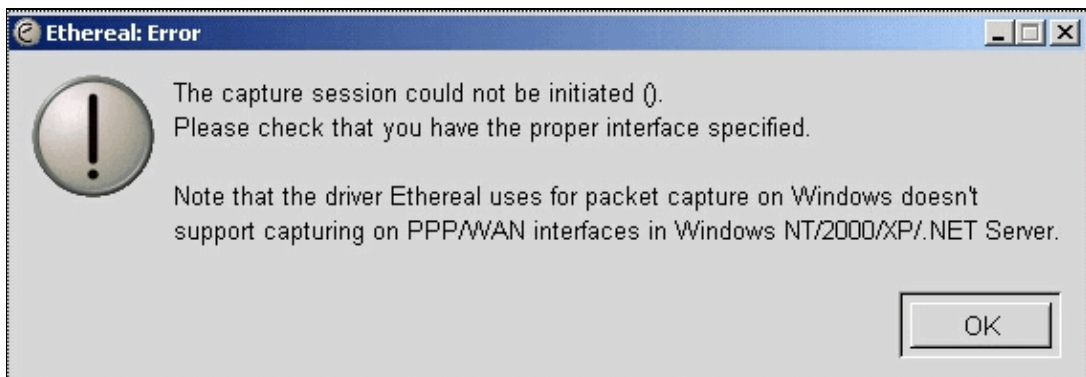

Configuring for Local SPAN

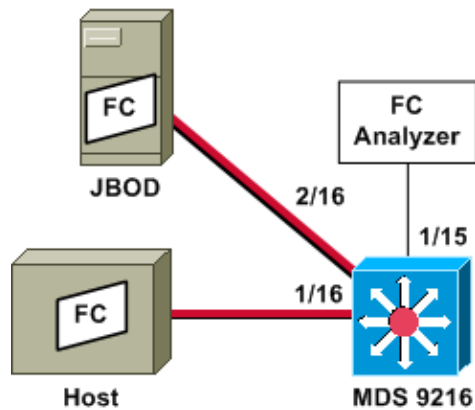

Note: The intent is to collect with the FC analyzer on port 1/15 FC frames to and from the host on port 1/16 of the 9216.

An FC analyzer on port 1/15 shows ordered sets, but not the ordered sets that occur on the link that is being SPANed. The FC analyzer device can be a Port Analyzer Adapter (PAA) and a PC that is running Ethereal, similar to a Finisar device.

MDS 9216 Configuration

```
MDS9216# show run

vsan 13

vsan 13 interface fc1/16
vsan 13 interface fc2/16

boot system bootflash:/m9200-ek9-mzg.1.2.0.77.bin
boot kickstart bootflash:/m9200-ek9-kickstart-mzg.1.2.0.77.bin

interface fc1/15
switchport mode SD
switchport speed 2000
no shutdown

interface fc1/16
no shutdown

interface mgmt0
ip address 172.18.172.56 255.255.255.0

span session 1
destination interface fc1/15
source interface fc1/16 rx

source interface fc1/16 tx
```

MDS 9216 Displays

```
MDS9216# show interface fc 1/15

fc1/15 is up
Hardware is Fibre Channel
Port WWN is 20:0f:00:05:30:00:47:9e
Admin port mode is SD
Port mode is SD
Port vsan is 1
Speed is 2 Gbps
Beacon is turned off
```

```
5 minutes input rate 73704 bits/sec, 9213 bytes/sec, 13 frames/sec
5 minutes output rate 2275584 bits/sec, 284448 bytes/sec, 430 frames/sec
2839098 frames input, 1883173240 bytes
  0 discards, 0 errors
  0 CRC, 0 unknown class
  0 too long, 0 too short
3049460 frames output, 2038253240 bytes
  0 discards, 0 errors
0 input OLS, 0 LRR, 0 NOS, 0 loop inits
0 output OLS, 0 LRR, 0 NOS, 0 loop inits
```

MDS9216# **show interface fc 1/16**

```
fc1/16 is up
Hardware is Fibre Channel
Port WWN is 20:10:00:05:30:00:47:9e
Admin port mode is auto, trunk mode is on
Port mode is FL, FCID is 0x660100
Port vsan is 13
Speed is 2 Gbps
Transmit B2B Credit is 0
Receive B2B Credit is 16
Receive data field Size is 2112
Beacon is turned off
5 minutes input rate 771568 bits/sec, 96446 bytes/sec, 171 frames/sec
5 minutes output rate 1503144 bits/sec, 187893 bytes/sec, 258 frames/sec
1238843 frames input, 691853044 bytes
  0 discards, 0 errors
  0 CRC, 0 unknown class
  0 too long, 0 too short
1864744 frames output, 1357707740 bytes
  0 discards, 0 errors
0 input OLS, 0 LRR, 0 NOS, 49 loop inits
10 output OLS, 0 LRR, 10 NOS, 14 loop inits
```

MDS9216# **show interface fc 2/16**

```
fc2/16 is up
Hardware is Fibre Channel
Port WWN is 20:50:00:05:30:00:47:9e
Admin port mode is FX
Port mode is FL, FCID is 0x660000
Port vsan is 13
Speed is 1 Gbps
Transmit B2B Credit is 0
Receive B2B Credit is 12
Receive data field Size is 2112
Beacon is turned off
5 minutes input rate 1647552 bits/sec, 205944 bytes/sec, 283 frames/sec
5 minutes output rate 845624 bits/sec, 105703 bytes/sec, 188 frames/sec
1867680 frames input, 1361393600 bytes
  0 discards, 0 errors
  0 CRC, 0 unknown class
  0 too long, 0 too short
1241179 frames output, 694505284 bytes
  0 discards, 0 errors
0 input OLS, 0 LRR, 0 NOS, 2 loop inits
0 output OLS, 0 LRR, 0 NOS, 2 loop inits
```

MDS9216# **show fcns data vsan 13**

VSAN 13:

```
-----
FCID          TYPE  PWWN                               (VENDOR)          FC4-TYPE:FEATURE
-----
0x6600dc      NL    21:00:00:20:37:15:a2:49 (Seagate)         scsi-fcp:target
```

```
0x6600e0    NL    21:00:00:04:cf:6e:4a:8c (Seagate)    scsi-fcp:target
0x6600e1    NL    21:00:00:04:cf:6e:37:8b (Seagate)    scsi-fcp:target
0x660101    NL    10:00:00:01:73:00:81:82 (JNI)
```

Total number of entries = 4

MDS9216# **show span session brief**

```
-----
Session  Admin          Oper          Destination
         State          State          Interface
-----
  1      no suspend    active        fc1/15
```

MDS9216# **show span session 1**

```
Session 1 (active)
  Destination is fc1/15
  No session filters configured
  Ingress (rx) sources are
    fc1/16,
  Egress (tx) sources are
    fc1/16,
```

MDS9216# **show span internal info session 1**

```
=====
Admin Configuration for session [1]
=====
Name:
Destination port: [100e000] [fc1/15] Flags [1]
State: [0] not suspended
Session Flags: [0] <>
Session Filter rx: none
Session Filter tx: none
Source interface - rx: fc1/16
Source interface - tx: fc1/16
Source vsan (rx): none
Session [1] is UNLOCKED txn[0] cfg[0] rid[80000000]
=====
Runtime Data for session [1]
=====
Status <active: 0 inactive 1> : [0] active
State reason:[0] Flags [6]rx_span_bit [0] tx_span_bit[1] ( 4s invalid)
oper configured PHYSICAL ports
fc1/16
PHYSICAL ports undergoing configuration
none
PHYSICAL ports in error state
none
PHYSICAL ports (incl. dest) link status
fc1/15, fc1/16
```

Configuring for Remote SPAN

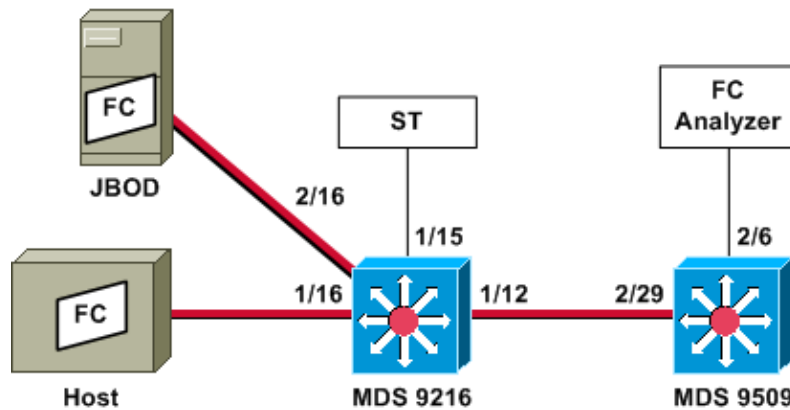

Note: The intent is to collect with the FC analyzer attached to the 9509 FC frames to and from the host on the 9216. The ST interface must have a Gigabit Interface Converter (GBIC) installed and the speed must match the Span Destination (SD) port on the 9509.

Before you attempt to configure RSPAN, ensure that these points are addressed:

- All switches must be running MDS code 1.2 or later.
- No cable should be attached to the Small Form factor pluggable (SFP) in the Span Terminal (ST) port.
- Make sure that the FC tunnel is UP before you begin to collect frames.
- FC analyzer can be a PAA and a PC that is running Ethereal, similar to a Finisar device.

If there are any intermediate switches between the SPAN source and the SPAN destination switch, follow this procedure:

1. Create an active VSAN interface in the same subnet as the tunnel source and destination.
2. Enable IP routing.
3. Enable FC-tunneling.
4. Use SAN-OS 1.2 or later.

MDS 9216 Configuration

```
MDS9216# show version
```

```
Cisco Storage Area Networking Operating System (SAN-OS) Software
TAC support: http://www.cisco.com/tac
Copyright (c) 2002-2003 by Cisco Systems, Inc. All rights reserved.
The copyright for certain works contained herein are owned by
Andiamo Systems, Inc. and/or other third parties and are used and
distributed under license.
```

```
Software
```

```
BIOS:      version 1.0.7
loader:    version 1.0(3a)
kickstart: version 1.2(1) [build 1.2(0.77)] [gdb]
system:    version 1.2(1) [build 1.2(0.77)] [gdb]
```

```
BIOS compile time:      03/20/03
kickstart image file is: bootflash:/m9200-ek9-kickstart-mzg.1.2.0.77.bin
kickstart compile time: 6/29/2003 0:00:00
system image file is:   bootflash:/m9200-ek9-mzg.1.2.0.77.bin
system compile time:    6/29/2003 0:00:00
```

```
Hardware
```

```
RAM 963108 kB
```

```
bootflash: 503808 blocks (block size 512b)
```

```
slot0:          0 blocks (block size 512b)

MDS9216 uptime is 0 days 21 hours 28 minute(s) 20 second(s)

Last reset at 50030 usecs after Thu Jul  3 13:09:31 2003
Reason: Reset Requested by CLI command reload
System version: 1.2(0.45c)

MDS9216# show run

Building Configuration ...

interface fc-tunnel 13
destination 10.0.0.2
source 10.0.0.1
no shutdown

vsan database
vsan 13

interface vsan13
ip address 10.0.0.1 255.255.255.0
no shutdown

vsan 13 interface fc1/16
vsan 13 interface fc2/16

boot system bootflash:/m9200-ek9-mzg.1.2.0.77.bin
boot kickstart bootflash:/m9200-ek9-kickstart-mzg.1.2.0.77.bin
fc-tunnel enable

ip routing
zone default-zone permit vsan 13

interface fc1/12
no shutdown

interface fc1/15
switchport mode ST
switchport speed 1000
rspan-tunnel interface fc-tunnel 13
no shutdown

interface fc1/16
no shutdown

interface fc2/16
no shutdown

interface mgmt0
ip address 172.18.172.56 255.255.255.0

span session 1
destination interface fc-tunnel 13
source interface fc1/16 rx

source interface fc1/16 tx

!--- Output suppressed.
```

MDS 9216 Displays

```
MDS9216# show interface fc 1/16

fc1/16 is up
```



```
Hardware is Fibre Channel
Port WWN is 20:10:00:05:30:00:47:9e
Admin port mode is auto, trunk mode is on
Port mode is FL, FCID is 0x660100
Port vsan is 13
Speed is 2 Gbps
Transmit B2B Credit is 0
Receive B2B Credit is 16
Receive data field Size is 2112
Beacon is turned off
5 minutes input rate 1480080 bits/sec, 185010 bytes/sec, 331 frames/sec
5 minutes output rate 2907712 bits/sec, 363464 bytes/sec, 498 frames/sec
  574444 frames input, 320246452 bytes
    0 discards, 0 errors
    0 CRC, 0 unknown class
    0 too long, 0 too short
  865170 frames output, 629303788 bytes
    0 discards, 0 errors
  0 input OLS, 0 LRR, 0 NOS, 10 loop inits
  5 output OLS, 0 LRR, 5 NOS, 9 loop inits
```

MDS9216# **show interface fc 2/16**

```
fc2/16 is up
Hardware is Fibre Channel
Port WWN is 20:50:00:05:30:00:47:9e
Admin port mode is FX
Port mode is FL, FCID is 0x660000
Port vsan is 13
Speed is 1 Gbps
Transmit B2B Credit is 0
Receive B2B Credit is 12
Receive data field Size is 2112
Beacon is turned off
5 minutes input rate 2905056 bits/sec, 363132 bytes/sec, 498 frames/sec
5 minutes output rate 1480184 bits/sec, 185023 bytes/sec, 330 frames/sec
  867932 frames input, 632889576 bytes
    0 discards, 0 errors
    0 CRC, 0 unknown class
    0 too long, 0 too short
  576681 frames output, 322771132 bytes
    0 discards, 0 errors
  0 input OLS, 0 LRR, 0 NOS, 2 loop inits
  0 output OLS, 0 LRR, 0 NOS, 2 loop inits
```

MDS9216# **show interface fc 1/15**

```
fc1/15 is up
Hardware is Fibre Channel
Port WWN is 20:0f:00:05:30:00:47:9e
Admin port mode is ST
Port mode is ST
Port vsan is 1
Speed is 1 Gbps
Rspan tunnel is fc-tunnel 13
Beacon is turned off
5 minutes input rate 4391896 bits/sec, 548987 bytes/sec, 827 frames/sec
5 minutes output rate 4391896 bits/sec, 548987 bytes/sec, 820 frames/sec
  1431232 frames input, 941079708 bytes
    0 discards, 0 errors
    0 CRC, 0 unknown class
    0 too long, 0 too short
  1406853 frames output, 941079708 bytes
    0 discards, 0 errors
  0 input OLS, 0 LRR, 0 NOS, 0 loop inits
  0 output OLS, 0 LRR, 0 NOS, 0 loop inits
```

MDS9216# **show interface fc 1/12**

```
fc1/12 is trunking
  Hardware is Fibre Channel
  Port WWN is 20:0c:00:05:30:00:47:9e
  Peer port WWN is 20:5d:00:05:30:00:51:1e
  Admin port mode is auto, trunk mode is on
  Port mode is TE
  Port vsan is 1
  Speed is 2 Gbps
  Transmit B2B Credit is 12
  Receive B2B Credit is 255
  Receive data field Size is 2112
  Beacon is turned off
  Trunk vsans (admin allowed and active) (1-5,13,20,777)
  Trunk vsans (up) (1,13)
  Trunk vsans (isolated) (2-5,20,777)
  Trunk vsans (initializing) ()
  5 minutes input rate 384 bits/sec, 48 bytes/sec, 0 frames/sec
  5 minutes output rate 4458296 bits/sec, 557287 bytes/sec, 827 frames/sec
  19865 frames input, 2220112 bytes
    0 discards, 0 errors
    0 CRC, 0 unknown class
    0 too long, 0 too short
  1468709 frames output, 971064244 bytes
    0 discards, 0 errors
  0 input OLS, 2 LRR, 0 NOS, 0 loop inits
  2 output OLS, 2 LRR, 0 NOS, 2 loop inits
```

MDS9216# **show interface fc-tunnel 13**

```
fc-tunnel 13 is up
Dest IP Addr: 10.0.0.2 Tunnel ID: 13
Source IP Addr: 10.0.0.1 LSP ID: 1
Explicit Path Name:
Outgoing interface: fc1/12
Outgoing Label(s) to Insert: 10005:0:1:ff'h
Record Routes:
10.0.0.2
```

MDS9216# **show interface vsan 13**

```
vsan13 is up, line protocol is up
  WWPN is 10:00:00:05:30:00:47:9f, FCID is 0x660201
  Internet address is 10.0.0.1/24
  MTU 1500 bytes, BW 1000000 Kbit
  2207 packets input, 170332 bytes, 0 errors, 0 multicast
  14952 packets output, 2225444 bytes, 0 errors, 0 dropped
```

MDS9216# **show span session 1**

```
Session 1 (active)
  Destination is fc-tunnel 13
  No session filters configured
  Ingress (rx) sources are
    fc1/16,
  Egress (tx) sources are
    fc1/16,
```

MDS9216# **show fc-tunnel internal states**

```
number of sessions : 1
Sess: 10.0.0.2 Tunnel-ID 13 Ext-Tunnel-ID 10.0.0.1
```

MDS9216# **show fc-tunnel internal data**

```
vsan interfaces:
  vsan 13: 10.0.0.1/255.255.255.0 [2]
  vsan 2: 15.0.0.4/255.255.255.0 [2]
next hop switch information:
  10.0.0.2 {vsan (13), 0x6b0001/8}: [4] fc1/12
layer 2 interfaces:
  fc1/12: Trunking, Up
```

MDS 9509 Configuration

```
RTP-9509-1# show run
```

```
Building Configuration ...
vsan database
vsan 13

  interface vsan13
  ip address 10.0.0.2 255.255.255.0
  no shutdown

vsan 13 interface fc2/16

boot system bootflash:/m9500-sflek9-mzg.1.2.0.77.bin sup-1
boot kickstart bootflash:/m9500-sflek9-kickstart-mzg.1.2.0.77.bin sup-1
boot system bootflash:/m9500-sflek9-mzg.1.2.0.77.bin sup-2
boot kickstart bootflash:/m9500-sflek9-kickstart-mzg.1.2.0.77.bin sup-2

fc-tunnel enable
fc-tunnel tunnel-id-map 13 interface fc2/6

ip routing

switchname RTP-9509-1

  interface fc2/6
  switchport mode SD
  switchport speed 1000
  no shutdown

  interface fc2/29
  switchport mode E
  no shutdown

  interface mgmt0
  ip address 172.18.172.57 255.255.255.0
```

MDS 9509 Displays

```
RTP-9509-1# show interface fc 2/29
```

```
fc2/29 is trunking
  Hardware is Fibre Channel
  Port WWN is 20:5d:00:05:30:00:51:1e
  Peer port WWN is 20:0c:00:05:30:00:47:9e
  Admin port mode is E, trunk mode is on
  Port mode is TE
  Port vsan is 501
  Speed is 2 Gbps
  Transmit B2B Credit is 255
  Receive B2B Credit is 12
  Receive data field Size is 2112
  Beacon is turned off
  Trunk vsans (admin allowed and active) (1,13,86,100,501)
  Trunk vsans (up) (1,13)
```

```
Trunk vsans (isolated)                (86,100,501)
Trunk vsans (initializing)            ( )
5 minutes input rate 4497752 bits/sec, 562219 bytes/sec, 835 frames/sec
5 minutes output rate 344 bits/sec, 43 bytes/sec, 0 frames/sec
1934604 frames input, 1285716656 bytes
    0 discards, 0 errors
    0 CRC, 0 unknown class
    0 too long, 0 too short
16903 frames output, 932076 bytes
    0 discards, 0 errors
1 input OLS, 1 LRR, 2 NOS, 0 loop inits
3 output OLS, 1 LRR, 2 NOS, 0 loop inits
```

RTP-9509-1# **show interface fc 2/6**

```
fc2/6 is up
Hardware is Fibre Channel
Port WWN is 20:46:00:05:30:00:51:1e
Admin port mode is SD
Port mode is SD
Port vsan is 1
Speed is 1 Gbps
Beacon is turned off
5 minutes input rate 0 bits/sec, 0 bytes/sec, 0 frames/sec
5 minutes output rate 4421448 bits/sec, 552681 bytes/sec, 835 frames/sec
0 frames input, 0 bytes
    0 discards, 0 errors
    0 CRC, 0 unknown class
    0 too long, 0 too short
1912319 frames output, 1263982444 bytes
    0 discards, 0 errors
0 input OLS, 0 LRR, 0 NOS, 0 loop inits
0 output OLS, 0 LRR, 0 NOS, 0 loop inits
```

RTP-9509-1# **show interface fc-tunnel 13**

% invalid interface range detected at '^' marker.

!--- This is because the tunnel is not defined on the 9509.

RTP-9509-1# **show interface vsan 13**

```
vsan13 is up, line protocol is up
WWPN is 10:00:00:05:30:00:51:23, FCID is 0x6b0001
Internet address is 10.0.0.2/24
MTU 1500 bytes, BW 1000000 Kbit
15071 packets input, 2243728 bytes, 0 errors, 1 multicast
2342 packets output, 185864 bytes, 0 errors, 0 dropped
```

RTP-9509-1# **show fc-tunnel tunnel-id-map**

```
tunnel id egress interface
    13          fc2/6
    14
```

RTP-9509-1# **show fc-tunnel internal states**

```
number of sessions : 1
Sess: 10.0.0.2 Tunnel-ID 13 Ext-Tunnel-ID 10.0.0.1
```

RTP-9509-1# **show fc-tunnel internal data**

```
vsan interfaces:
  vsan 13: 10.0.0.2/255.255.255.0 [2]
next hop switch information:
layer 2 interfaces:
```

Notes for Port Analyzer Adapter Devices

The Ethernet port is copper, and it has auto-detects speeds of 1 Gbps or 100 Mbps. Ethereal 0.9(9) or later and WinPcap must be installed on the PC.

The FC port requires an SFP and an LC-to-LC cable for attachment to the MDS.

These are switch settings on the PAA:

- Switch positions are numbered 1, 2, 3, and 4 from left to right.
- In the next list, a 1 indicates that the dip switch is ON or UP. A 0 indicates the dip switch is DOWN or OFF.

```
0001 1G  NTM
1001 1G  ETM
0101 1G  STM
0011 1G  DTM
```

```
0000 2G  NTM
1000 2G  ETM
0100 2G  STM
0010 2G  DTM
```

```
1111 1G  MNM
```

!--- Used for diagnostics only.

- Switch 4 dictates the speed (on = 1G, off = 2G). Switches 1, 2, and 3 dictate truncate mode. Any changes require a power cycle.

These are the modes:

- No Truncate Mode (NTM) FC frames are passed without any modifications.
- Ethernet Truncate Mode (ETM) Reduces the payload size from 528 lines to 368 lines, to truncates FC frame to a maximum of 1496 bytes.
- Shallow Truncate Mode (STM) Reduces the payload size from 528 lines to 58 lines, to truncates FC frame to a maximum of 256 bytes.
- Deep Truncate Mode (DTM) Reduces the payload size from 528 lines to 10 lines, to truncates FC frame to a maximum of 64 bytes.

Verify

There is currently no verification procedure available for this configuration.

Troubleshoot

There is currently no specific troubleshooting information available for this configuration.

Related Information

- **MDS 9000 Multilayer Switches Hardware Support**
- **Storage Networking Product Support**
- **Technical Support – Cisco Systems**

[Contacts & Feedback](#) | [Help](#) | [Site Map](#)

© 2014 – 2015 Cisco Systems, Inc. All rights reserved. [Terms & Conditions](#) | [Privacy Statement](#) | [Cookie Policy](#) | [Trademarks of Cisco Systems, Inc.](#)

Updated: Jul 23, 2008

Document ID: 46220
