

Understanding VP Tunnels and VP Switching

Document ID: 10532

Contents

Introduction

Prerequisites

- Requirements
- Components Used
- Conventions

Virtual Paths and Virtual Channels

VP Switching

VP Tunnels

- VP Tunnel Restrictions

ATM Switching Summary

show Commands

Related Information

Introduction

A Virtual Path Tunnel interface (VPI) is a multiplexing/demultiplexing point on an ATM switch (LS1010 and Catalyst 8540-MSR) at which Virtual Channels (VCs) from various sources (ATM interfaces) are aggregated to a Virtual Path on an interface. VPs are often used when traffic is transported across a WAN. VPs are ATM connections that consist of multiple VCs that all have the same VPI number. They pass through ATM switches that handle VP switching.

This document discusses some important concepts related to VP tunnels and switching. It also contains links to related sample configurations and other reference documents. This document focuses on the LS1010, Catalyst 8510-MSR, and Catalyst 8540-MSR enterprise ATM switches.

Prerequisites

Requirements

There are no specific requirements for this document.

Components Used

The information in this document is based on these software and hardware versions:

- VP switching is supported on the LS1010 and Catalyst 8540-MSR.
- VP tunnel interfaces are supported on the LS1010, Catalyst 8540-MSR, 7200 router with PA-A2 or PA-A3, and 7500 series routers with PA-A3.
- Shaped VP tunnels of the CBR service category are supported on the LS1010 with FC-PFQ, Catalyst 8510-MSR, Catalyst 8540-MSR, 7500 series router with PA-A3, and 7200 series routers with PA-A2 or PA-A3, 7500 series routers with PA-A6, and 7200 series routers with PA-A6. All VCs within CBR VP tunnels must be of the same service category. Shaped VP tunnels are first supported in Cisco IOS® Software Release 11.2(8.0.1)FWA4. Cisco IOS Software Release 11.1 and WA3 release trains do not support shaped VP tunnels. For Cisco IOS Software Releases after 11.3(0.8)TWA4, shaped VP tunnels are supported for non-CBR service category VCs within a shaped tunnel. For earlier software versions that do support shaped VP tunnels, VCs within shaped

CBR tunnels must be of the CBR service category.

- Unshaped VP tunnels of any service category are supported on the LS1010 (with either FC-PCQ or FC-PFQ), Catalyst 8540-MSR, Catalyst 8510-MSR, 7500 series routers with PA-A3, and 7200 series routers with PA-A2 or PA-A3, 7500 series routers with PA-A6, and 7200 series routers with PA-A6. Cisco IOS Software Releases 11.2, 11.3, or 12.0 support this feature. VCs within unshaped tunnels have to be of the same service category as the unshaped VP tunnels.
- Hierarchical VP tunnels of the CBR service category are supported on the LS1010 with FC-PFQ, Catalyst 8510-MSR, and Catalyst 8540-MSR. The minimum software requirement is the W5 train of Cisco IOS. Remember that VCs within hierarchical VP tunnels can be of multiple service categories.

The information in this document was created from the devices in a specific lab environment. All of the devices used in this document started with a cleared (default) configuration. If your network is live, make sure that you understand the potential impact of any command.

Conventions

For more information on document conventions, refer to the Cisco Technical Tips Conventions.

Virtual Paths and Virtual Channels

There are two major types of ATM connections: VC (Virtual Channel) and VP (Virtual Path). They differ in the way they are identified. Therefore, in the way they are switched. VCs are uniquely identified on a port of an ATM switch by the VPI and VCI numbers. VPs are uniquely identified on the ATM port by VPI number only. You can think of a VP as something that consists of all VCs with a specified VPI number on the ATM port.



VP Switching

ATM cells that arrive on a VC are switched based on both the VPI and VCI number in the cell header. On the other hand, ATM cells that arrive on a VP are switched based on the VPI number only. Configuration of the ATM switch determines if the switch is supposed to be VC or VP switching for the specified VPI/VCI pair or VPI respectively. Switching based solely on the VPI number is called VP switching. Note that the VCI remains unchanged for all VCs in the VP. In other words, all VCs in the VP contain the same VCI number at the ingress and egress side of the VP (end to end).

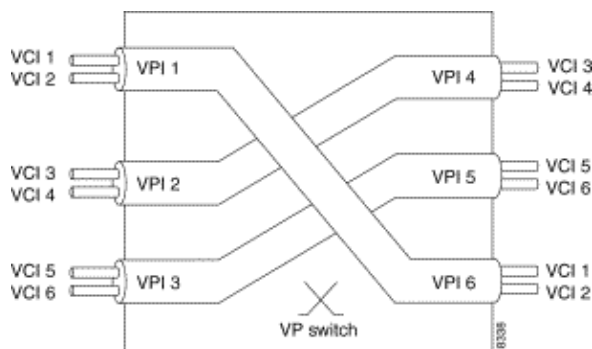

VP Tunnels

A VP tunnel interface is the terminating point of the VP. You can think of it as a border between VP and VC switching domains. At a VP tunnel interface, the ATM switch multiplexes/demultiplexes VCs to the VP. In other words, it aggregates VCs that come from multiple or identical switch ports to the VP.

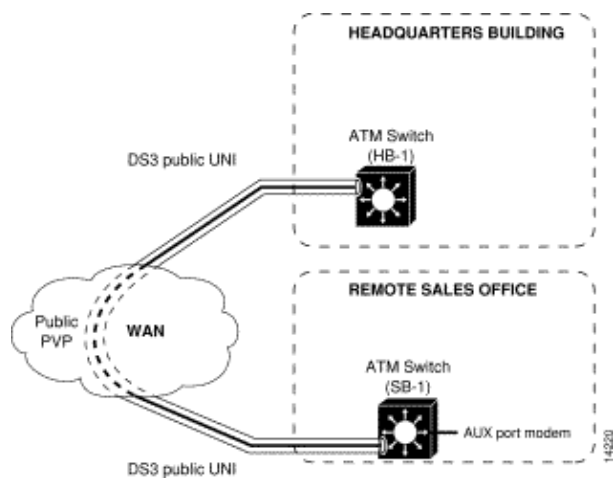

VPs are most often used across WANs. When a VP is provided by a service provider, the contract specifies a service category of VP (CBR, VBR-rt, VBR-nrt, UBR, ABR), as well as the traffic parameters of the VP. To ensure the contract is honored, the service provider polices the network based on traffic parameters defined in the contract. To ensure that no cells are dropped due to policing, traffic shaping needs to be implemented on the customer premise equipment (CPE). CPEs also need to traffic shape on an aggregate VP since policing is done for a VP as aggregate and not on individual VCs. Traffic shaping on CPEs is most commonly implemented with shaped VP tunnels. Note that each VC within a tunnel is provided individual traffic guarantee. CBR shaped VP tunnels are supported on LS1010 equipped with FC-PFQ, Catalyst 8540-MSR, 7200 with PA-A2, and 7500 with PA-A2 or PA-A3. Note that LS1010 with FC-PCQ (Feature card 1) does not support shaped VP tunnels. Another limitation of shaped VP tunnels on Cisco enterprise ATM switches is that all VCs within a single VP tunnel need to be of same service category. See the Components Used section for more details on restrictions and requirements.

To overcome the latest limitation of shaped VP tunnels, Cisco enterprise ATM switches now implement hierarchical VP tunnels. Hierarchical VP tunnels allow VCs of different service categories to coexist in the same VP tunnel. With hierarchical VP tunnels, the user does not need to buy multiple VPs from the service provider to carry different service categories. Note that even with Hierarchical VP tunnels, only CBR shaped tunnels are supported (for instance, VP tunnels can be shaped only if it is defined as CBR service category). However, service providers most often provide CBR VPs so this limitation is not as restrictive as it might appear.

On Cisco enterprise switches, there are three different types of VP tunnels:

- **Regular or unshaped VP tunnels:** VP tunnels on which there is no traffic shaping for any ATM service category. The VP can be of any service category, but it can't be shaped. VCs in a tunnel have to be of the same service category as the VP tunnel. If the VP service provider is policing, the connection will most likely experience cell drops in the service provider network.
- **Shaped VP tunnels:** VP tunnels that are traffic shaped. They are defined only for CBR service category on Cisco enterprise ATM switches. Depending on version of IOS VCs within tunnel either must be CBR service category or can be of any other service category. However, all VCs within a single VP tunnel must be of the same service category. Note that VCs within the tunnel will be shaped to the traffic parameters specified for individual the VC. Also, if VCs of multiple service categories need to be transported across the VP tunnel, multiple VP tunnels need to be purchased and

configured. For instance, if Circuit Emulation VCs (CBR) and LANE VCs (UBR) need to be transported between two sites, you can not transport them using a single VP tunnel. Instead, two VP tunnels need to be purchased. Note that both VP tunnels need to be CBR tunnels: one tunnel will be used for CBR VCs and the other for UBR VCs.

- **Hierarchical VP tunnels:** VP tunnels that are traffic shaped and support VCs of multiple service categories to coexist in a tunnel. Shaping is still supported only for CBR VP tunnels. VCs within hierarchical tunnels can be of any service category and VCs of multiple service categories can coexist in same VP tunnel. There is no need to purchase two VP tunnels in the example above where LANE and CES VCs need to be transported between two sites. One VP tunnel can be purchased and configured as a hierarchical VP tunnel, which allows both UBR and CBR VCs to be transported in one CBR VP.

VP Tunnel Restrictions

These restrictions apply to shaped VP tunnels:

1. LS1010 with FC–PFQ and Catalyst 8510–MSR support a maximum of $2 \times 64 = 128$ shaped VP tunnels: 64 shaped VP tunnels on $x/0/y$ numbered ports and 64 on $x/1/y$ numbered ports.
2. Catalyst 8540–MSR supports a maximum of $8 \times 64 = 512$ shaped VP tunnels. A maximum of 64 shaped VP tunnels can be defined on each of the following interface groups: (0/0/x, 1/0/x), (0/1/x, 1/1/x), (2/0/x, 3/0/x), (2/1/x, 3/1/x), (9/0/x, 10/0/x), (9/1/x, 10/1/x), (11/0/x, 12/0/x), and (11/1/x, 12/1/x).
3. The bandwidth of the shaped VP tunnel is shared by the active VCs inside the tunnel in strict round–robin (RR) fashion.
4. Shaped VP tunnels do not support merged VCs for tag switching.
5. UBR+ and ABR VCs with non–zero MCRs are not allowed on a shaped VP tunnel interface.
6. A maximum of 128 VCs can travel a shaped VP tunnel interface.

The following restrictions apply to hierarchical VP tunnels:

1. LS1010 with FC–PFQ, Catalyst 5500 with ASP and FC–PFQ, and Catalyst 8510–MSR support a maximum of 62 hierarchical VP tunnels.
2. Hierarchical VP tunnels can only be defined on ports in slots 0 and 3 on the LS1010 and Catalyst 8510–MSR. Hierarchical VP tunnels can be defined in slots 9 and 11 on a Catalyst 5500 with ASP and FC–PFQ.
3. A LS1010 equipped with FC–PFQ and ASP–B supports a maximum of 30 hierarchical VP tunnels on ports 0/0/z and 3/0/z combined and a maximum of 32 on ports 0/1/z and 3/1/z combined. Use the **show hardware** command to find out the type of ASP and feature card.
4. A LS1010 equipped with FC–PFQ and ASP–C and a Catalyst 8510–MSR support a maximum of 30 hierarchical VP tunnels on ports 0/y/z and a maximum of 32 on ports 3/y/z.
5. On a Catalyst 5500 with ASP and FC–PFQ, a maximum of 30 hierarchical VP tunnels can be defined on ports 9/0/z and 11/0/7 combined. A maximum of 32 hierarchical VP tunnels can be defined on ports 9/1/z and 11/1/z combined.
6. On a Catalyst 8540–MSR, hierarchical VP tunnels can be defined on slots 0,2,9, and 11.
7. The maximum number of hierarchical VP tunnels varies between 120 and 240. This depends on the type of PAMs used. If all of the ports are Super PAMs (full width modules), the maximum number of supported VP tunnels is 240. If all of the ports installed are Super CAMs with LS1010 PAMs, the maximum number of hierarchical VP tunnels is 120.
8. Hierarchical VP tunnels can not coexist with any other type of connection (VCs, VPs, Tag VCs, regular or shaped VP tunnels, and so forth) on the same physical interface. The only type of connection that can coexist with hierarchical VP tunnels on the same physical interface are additional hierarchical VP tunnels and well known VCs (signaling 0/5, PNNI, 0/18, ILMI 0/16 etc.).
9. Hierarchical VP tunnels can support only ATM Forum VCs or only Tag VCs, but not both at the same time.

10. When an online insertion and removal (OIR) is performed of a PAM that has hierarchical VP tunnels configured for its ports, configuration of the hierarchical tunnel is preserved. So if the same PAM is inserted back in, the hierarchical VP tunnel is automatically active. However, if a different type of PAM is to be inserted, it is strongly recommended that any configured hierarchical VP tunnel (on port about to be removed) be deleted prior to the physical removal of PAM.

ATM Switching Summary

ATM virtual circuits exist locally (on a link between two adjacent ATM switches or two CPEs and have two identifiers: VPI (Virtual Path Identifier) and VCI (Virtual Channel Identifier). These two identifiers are often referred to as a VPI/VCI pair. VPI and VCI numbers are part of ATM cell headers and they are therefore carried in each ATM cell. Since there are two identifiers (unlike a frame relay that has only one), you can have two different types of ATM connections: VP (virtual path) and VC (virtual channel). This hierarchy allows aggregation of the number of VCs in one "fat" pipe (VP) between sites that need a large number of VCs.

The ATM switch is responsible for switching ATM cells on both the VC and VP. When the ATM switch is configured to switch cells on a VC, it has to look at both VPI and VCI fields of the cell in order to make a switching decision. Switching is done based on a table containing (port, VPI, VCI) tuples for the input and output side of the VC. On Cisco ATM switches, you can see this table with the **show atm vc** command. You can also configure the ATM switch to switch cells based only on the port and VPI number; that is called VP switching. For VP switching, the ATM switch uses a table consisting of (port, VPI) pairs for input and output. You can see this table on Cisco ATM switches with the **show atm vp** command. Note that when VP switching, the ATM switch needs to read only the VPI field of each ATM cell to make a switching decision. This reduces the processing time. The same holds true for cell header rewrites. For example, in VC switching, both VPI and VCI fields of the cell header are rewritten and possibly changed. However, in VP switching, only VPI fields can be changed and the VCI field remains the same end-to-end.

The VP is always terminated with the VP tunnel interface. VP Tunnel is a virtual interface defined on the ATM switch or router. VP tunnels are multiplexing/demultiplexing multiple VCs from multiple interfaces (can also be all the same interface) to the VP tunnel interface. When multiplexing, it changes the VPI field of VCs that go through the VP to be the same as the VPI number on the VPs. On other hand, VCI numbers can be arbitrary. However, for specific VCs, the VCI numbers on both VP tunnel interfaces (originating and terminating) need to be the same.

show Commands

- **show version** – Used to discover the Cisco IOS release and verify that you do have the required IOS to implement your configuration.
- **show running-config** – Used to see your configuration and to ensure that everything is configured way you intended.
- **Show interface x/y/z** – Used to verify that the interface is up and the line protocol is up (error counters are also shown). This command also lists any subinterfaces (for example, configured VP tunnels).
- **show interface x/y/z.n** – "n" is the VPI number of the VP tunnel. This command shows information specific to the VP tunnel subinterface.
- **show atm vp** – Used to show you which type of tunnel is configured or if VP switching is configured.
- **show atm VP interface x/y/z.n** – Used to show all specifics about VP tunnels with VPI=n. Make sure that the STATUS indicates the correct type of tunnel. Verify that Rx and Tx service categories are configured properly (for example, should be the same as the category of VP purchased from the service provider). Verify that the traffic parameters specified (PCR, SCR, MCR, CDVT, MBS) are what they need to be.

- **show atm vc interface atm $x/y/z$.n** – Used to show all VCs that go through the VP tunnel with VPI= n .
- **show atm vc interface atm $x/y/z$.n n m** – Used to show specifics about the VC with VPI/VCI= n/m that passes through the VP tunnel with VPI= n . It shows you the same specifics that the **show atm VP interface $x/y/z$ n** command shows for VP.
- **show atm resource** – Used to see if hierarchical scheduling is enabled.
- **show atm interface resource atm $x/y/z$** – Used to see allocated resources by all connections on the physical interface atm $x/y/z$. It also shows the total available resources on this interface.
- **show atm interface resource atm $x/y/z$.n** – Used to see the allocated resources by all VCs within the VP with VPI= n . It also shows the total available resources in the VP tunnel. This command is very useful when you try to determine if VCs with specific traffic parameters should be able to be established through the VP tunnel.

Related Information

- [Troubleshooting VP Tunnels](#)
- [Configuring ATM Network Interfaces](#)
- [Configuring Virtual Connections](#)
- [Configuring Resource Management](#)
- [ATM Commands](#)
- [LANE and CES across Unshaped VP Tunnels](#)
- [LANE, CES, and VBR PVC across Shaped VP Tunnels](#)
- [ATM Technology Support Page](#)
- [Technical Support – Cisco Systems](#)

[Contacts & Feedback](#) | [Help](#) | [Site Map](#)

© 2014 – 2015 Cisco Systems, Inc. All rights reserved. [Terms & Conditions](#) | [Privacy Statement](#) | [Cookie Policy](#) | [Trademarks of Cisco Systems, Inc.](#)

Updated: Nov 15, 2007

Document ID: 10532
