

# A Next-Generation Architecture for Cable Operator Networks Based on Software-Defined Networking and Network Function Virtualization

White Paper

September 2014

---

## 1. Executive Summary

The requirement for on-demand connectivity and real-time service delivery is a priority for service provider networks. Software-defined networking (SDN) and network function virtualization (NFV) enhance the ubiquitous cloud model to improve time to market and add new functionality such as dynamic capacity business VPNs, policy-based services, and bandwidth on demand.

We are entering an age of agile service creation with virtualized IT infrastructure, breaking down old constraints in many domains, including the delivery of services by cable operators. Two of the primary technologies that usher in this era are SDN and NFV.

SDN introduces a shift in how networks are designed, operationalized, and monetized and will make them far more agile and responsive to service requirements. NFV services can provide the real-time network resources needed to support this. Business and residential applications can be deployed on demand, and there are choices as to where each service may be placed. Further, the emergence of software-defined networks has heightened the ability to dynamically control the virtual or physical network and orchestrate these functions.

With SDN and NFV working in concert, revenue-generating services can be placed anywhere within the network and invoked as needed according to the needs of specific applications. This represents a clear opportunity for cable operators to better monetize their networks, because they can exploit their abilities to guarantee service-level agreements (SLAs) for premium services while continuing to provide volume-based services.

In parallel with SDN and NFV, the cable industry is seeing its own dramatic technology evolution as DOCSIS 3.1, converged cable access platform (CCAP), and Remote-PHY become available. These enable a more ubiquitous IP network to be deployed from the core to the node and provide an infrastructure on which the next generation of gigabit rate services can be deployed using SDN and NFV.

The DOCSIS 3.1, CCAP, and Remote-PHY changes to the physical infrastructure applied in combination with SDN and NFV virtual infrastructure enable the operator to provide more flexible services and to deliver services more quickly while also reducing capital expenditure and operating costs.

The commercial benefits of efficient and flexible network services do not come for free and bring new challenges to cable operators. They must transition from the current installed hardware-centric network to the software-driven network of the future. They must determine which network functions should be virtualized and then integrate the hardware and virtual implementations to deliver services. They must determine an operational model in this new world made up of virtual and real entities and develop the organizational and skill profiles needed to operate such an environment. Above all, they must execute these transitions within available budgets and while continuing to deliver profitable services.

## 2. Introduction

Changing business environments, increasing competition, and disruptive technology trends are having a significant effect on the design and operation of traditional service provider networks and service delivery. This paper will examine how these changes can be expected to affect cable operator networks in the coming years. It will make the assertion that these technology changes can provide a set of mechanisms that cable operators can use to continue their success in both residential and business service segments.

---

The paper is organized in the following sections:

- An overview of the business and technical changes driving the need for network evolution
- A look into cloud computing, SDN, and NFV, which are driving general service provider network changes, and a discussion on how networks need to evolve in response to these
- An investigation of cable specific technology changes, including CCAP, DOCSIS 3.1, and Remote-PHY, and their effects on cable operator networks
- Development of a potential scenario showing how the two sets of technology changes (general service provider and cable specific) can be combined to create the cable operator network of the future, how this can be used to more efficiently deliver services, and an illustration of a possible evolutionary path to get there
- A summary of the risks and benefits associated with the coming changes

### 3. Change Drivers in Service Provider Networks

#### 3.1 Business

The following business changes are of particular interest when considering the cable operator market:

- Increasing traffic volumes: Cisco VNI projects approximately 56 percent compound annual growth rate (CAGR) over the next five years [Cisco VNI 2013]. Business services will continue to demand not only higher data rates but also their delivery at a lower per unit cost.
- Internet of Everything (IoE), where a vast array of devices, sensors, and machines will become increasingly connected. This will drive up the overall number of connected devices and present additional service and backhaul opportunities to cable operators.
- An increasingly large portion of the service market will be consumed through mobile devices, including bring your own device (BYOD). Cable operators will need to provide integrated offerings over multiple access networks to remain competitive.
- A fixed or slowing average revenue per user (ARPU) associated with basic connectivity, meaning cable operators need to provide value-added services and better use their network infrastructure.
- Increased competition for basic connectivity from traditional telcos, new entrants such as Google and municipal fiber, and a threat from over-the-top (OTT) cloud-based service providers who attempt to decouple value-added services from basic access.
- The need for much faster service velocity. OTT service providers can use web-based tools and flexible virtual infrastructure to deliver new services at scale very quickly. Cable operators will need to be able to compete with this, which will require escaping their historic hardware, embedded software, and back-office bottlenecks.

#### 3.2 Technology

In parallel with the business changes discussed earlier, we have a corresponding set of technology changes:

- Cloud and data center technologies based on virtualization, massive scaling, and automation
- New networking paradigms such as SDN driving to simpler network hardware, a centralized control plane, and application-centric network programming APIs
- A move away from dedicated hardware appliances to running network services using NFV technologies
- CCAP next-generation access platforms, providing high-density integrated service platforms

- DOCSIS 3.1 upgrades to the physical layer, enabling higher bandwidth services
- Remote-PHY cable architectures, moving IP and Ethernet deeper into the network and relegating RF to the last hop from the fiber node to the customer

## 4. General Technology Changes Affecting Cable Operator Networks

### 4.1 Cloud Computing/Data Center

Over the last decade there has been a dramatic migration of compute and storage workloads to large centralized data centers. This has been driven by the economies of scale and supported by the development of sophisticated virtualization environments and tools to automate these operations. SDN and NVF both use this cloud infrastructure and are in fact largely enabled by it.

### 4.2 Software-Defined Networking (SDN)

In traditional switch and router architectures, it is normal for the control plane to be implemented in software running on a general-purpose CPU and for the data plane to be implemented with specialized hardware such as application-specific integrated circuits (ASICs), field-programmable gate arrays (FPGAs), or network processors (NPU). SDN takes this concept a step further by removing the control plane from the forwarding hardware and moving it into a server-based processing environment.

Software-defined networks are originally a network architecture vision championed by the Open Networking Foundation (ONF) [ONF ORG]. The current **ONF** definition of the SDN architecture is:

“This architecture (SDN) decouples the network control and forwarding functions enabling the network control to become directly programmable and the underlying infrastructure to be abstracted for applications and network services. The OpenFlow™ protocol is a foundational element for building SDN solutions.” [ONF SDN]

The diagram in [Figure 1](#) depicts the SDN architecture as defined by the ONF.

**Figure 1.** ONF Logical View of SDN

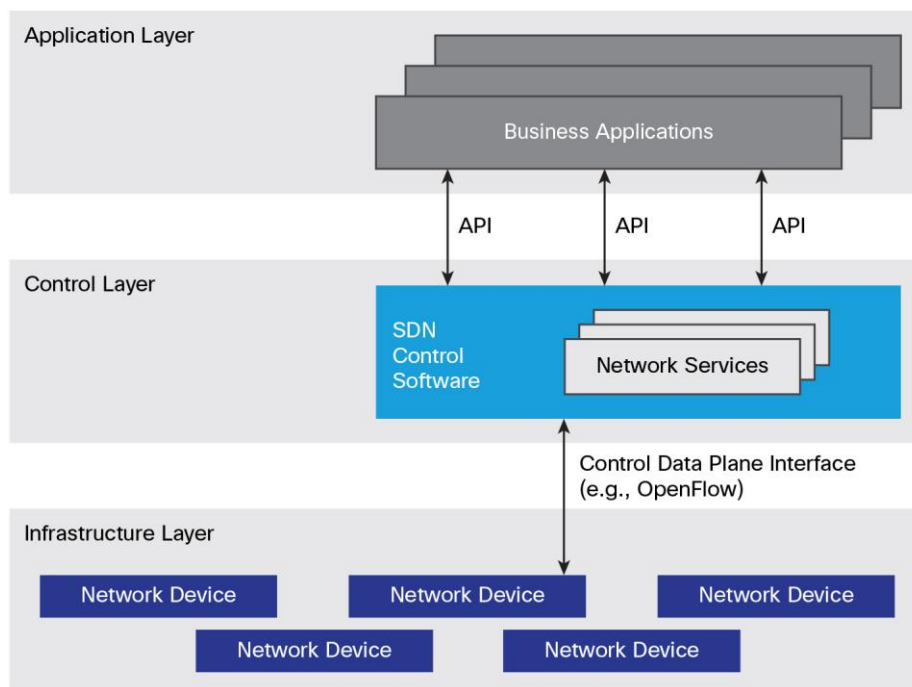

---

Thus, SDN is an architectural approach to building data networks, which provides central control and abstraction. It does this by decoupling the control plane and data plane from each other, such that the control plane resides centrally, and the forwarding components remain distributed.

The control layer provides northbound and southbound APIs:

- In the northbound direction, the control plane provides a common abstracted view of the network to higher level applications and programs, typically using high-level web services-style APIs.
- In the southbound direction, the control plane programs the forwarding behavior of the physical network equipment distributed around the network with device-level protocols or APIs. In the original SDN proposals, OpenFlow [OPENFL] was the API, but the concept has since been extended to include multiple API options.

The initial objectives of the SDN architecture recommended that the control plane be centralized in SDN controllers. These controllers have the following main functions:

- Maintaining a full view of the network
- Programming network equipment
- Providing a central view or abstraction point of the network for higher level applications
- Providing operations, management, and orchestration services to the network

With this architecture the network equipment performs the forwarding function as directed by the controller and has no local control plane function.

SDN offers multiple advantages:

- It uses the lower cost CPU cycles available from server platforms compared to embedded systems.
- It allows use of the better development environments and tools available for servers compared to embedded software.
- It enables a centralized view of the end-to-end network, enabling simpler decision making for functions such as path determination, failure handling, on-demand network programming, and resource orchestration.
- It can use the virtual machine environments and automation technology developed for data centers.
- It provides for better resource usage and easier scaling of the control plane because virtual machines can be spun up or down on demand.
- It retains the highly efficient packet-forwarding technology developed for the data plane.

### **4.3 Network Function Virtualization (NFV)**

NFV has similarities with SDN in that it moves functions out of dedicated network hardware into virtual machines running on standard server platforms. In this case the entire function is migrated to software so that both control and data planes run on the server as a complete replacement for the physical network appliance. Thus, with NFV the efficiencies of using dedicated forwarding hardware are traded against those of using industry standard servers and storage managed with virtualization technology.

The benefits of NFV are easy to visualize and include:

- Reduced cost and increased speed of innovation
- Reduced service development cycles
- Enablement of an ecosystem that encourages openness

- Service adaptability based on rapid scale-up/scale-down of services
- Reduced capital expense (CapEx) and operating expense (OpEx) costs

These benefits primarily arise because network functions can utilize the data center equipment and management techniques, rather than requiring specialized hardware and software solutions. As a consequence, resources can be pooled, and network functions can execute on industry standard servers. This increases the flexibility of the operator and allows operators to deploy services more quickly and adjust them quickly and simply based on user demand. There are also benefits from using standard x86 architecture, including a richer development environment and a potential reduction in overall costs.

## 5. Cable-Specific Technology Changes Affecting Cable Operator Networks

### 5.1 DOCSIS 3.1

As the next stage in the evolution of the DOCSIS protocol set, DOCSIS 3.1 introduces an update to the physical layer technology, enabling the use of higher orders of modulation and an expansion of usable spectrum. This results in increases in bandwidth, potentially up to 10 Gbps in the downstream and 1Gbps in the upstream. Refer to [CL DOC31] for details. This enables the hybrid fiber coax (HFC) network to be used to deliver much higher bandwidth services without needing to deploy fiber.

### 5.2 CCAP

Over the last several years, CCAP has emerged as the next-generation replacement for cable modem termination system (CMTS) and edge quadrature amplitude modulator (EQAM) products [CCAP]. The basic premise of CCAP is the convergence of data with broadcast and narrowcast video at very large scale. Service multiplexing occurs inside the CCAP platform, so that a full spectrum of services is available to each service group from a single port with no need for complex external RF combining. The service group port was originally conceived as an analog RF port, but the principle of full service spectrum via a single port has been extended so that a preformed service lineup can be delivered via Ethernet to a Remote-PHY node, where the RF conversion takes place (refer to section 5.3).

### 5.3 Fiber Deeper and Remote-PHY

The HFC network has traditionally used linear optics and RF technology in the network between the distribution hub and the home. As data bandwidth to existing service groups is exhausted, cable operators have been progressively reducing the size of the serving group through node splitting. Each split essentially doubles the aggregate bandwidth available to subscribers and moves fiber ever deeper into the network. A node split of course requires additional narrowcast service ports for the new service group that has been created. Fortunately, the CCAP platforms provide the cost and density needed to make this practical. To date node splits have continued to use the same analog technologies, so that each time a node splits, an additional wavelength must be transported from the distribution hub containing the service spectrum for the new service group.

Remote-PHY technology changes this by extending IP and Ethernet transport to the node over digital fiber, as shown in [Figure 2](#). The vast majority of functions remain in the CCAP core, but the conversion of digital signals to analog now takes place in the node rather than the distribution hub or headend. This enables the Remote-PHY node to be a simple physical layer device, which is unaware of service multiplexing complexities. The coaxial portion of the network and the customer premises equipment (CPE) remain analog. Signaling between the CCAP core and the Remote-PHY controls the node operation, while DOCSIS signaling is unchanged and remains end to end between the CCAP core and the cable modem.

**Figure 2.** Remote-PHY Architecture

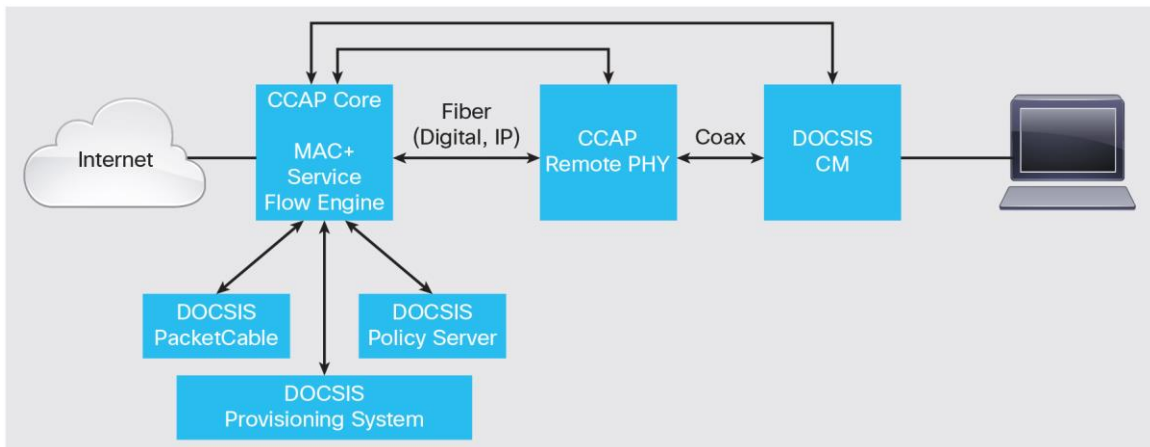

This has the potential to benefit service delivery because when the fiber network from the headend to the node is a digital IP network, it can easily be used for a combination of business and residential traffic. Sharing of the network between business and residential services can be achieved by multiplexing at wavelength, Ethernet, Multiprotocol Label Switching (MPLS), or IP layers.

## 6. A Next-Generation Cable Network

From the preceding sections we can see two sets of technology changes affecting the cable network, as shown in [Figure 3](#). How well the cable-specific changes (CCAP, fiber deeper, and Remote-PHY) can be combined with the more general technology changes (cloud, SDN, and NFV) will be crucial to providing successful business and residential services.

**Figure 3.** Technology Changes Affecting Cable Operator Networks

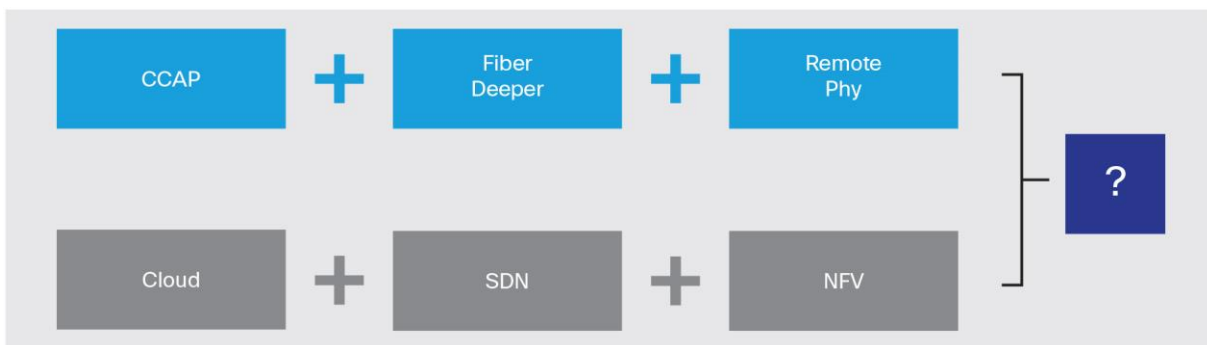

SDN introduces a shift in how networks are designed, operationalized, and monetized and can make them far more agile and responsive to service requirements. NFV services provide the real-time network resources needed to support this: Applications can now be deployed on demand, and there are choices as to where each service may be placed. Further, the emergence of software-defined networks has heightened the ability to dynamically control the network and orchestrate these functions.

Using the virtualized data center infrastructure and the SDN and NFV technologies it enables will be vital for cable operators to remain competitive.

---

Moving to this environment enables changes to be made in high-level software components rather than dedicated network hardware with the following benefits:

- Improved business agility
- Faster innovation and time to revenue
- Open programmable components
- Centralized, programmable control of the infrastructure
- Ease of customization and optimization
- Simplified operations to reduce OpEx

Clearly, SDN and NFV promise significant advantages. The primary question is how to achieve these within the constraints imposed by the cable network and how to evolve to it while maintaining customer services.

## 6.1 An Evolutionary Approach

SDN is a new architecture using an emerging suite of technologies, which are evolving quickly. For cable operators, it will not be possible to completely redesign the network based on SDN principles. So they need a path from today's networking solutions to a more open programmable infrastructure without the need for a comprehensive upgrade.

In the short to medium term, networks will be a mix of network functions executing on dedicated hardware and virtual network functions (VNFs) executing in cloud data centers.

Many of the components used to construct and support the base service functions of the network may continue to execute in dedicated platforms outside the NFV environment. In the cable operator network this could include elements such as the routing and switching infrastructure, the CCAP core platforms, and the Remote-PHY equipment. There are several reasons for this such as:

- They provide physical layer functionality that cannot be virtualized.
- They are deployed in a distributed fashion and are not amenable to being centralized.
- They provide much higher performance and efficiency than an x86-based equivalent.

Components associated with service and management functions will tend to migrate from dedicated servers and platforms toward the NFV environment. This includes network control elements (Dynamic Host Configuration Protocol [DHCP], packet cable multimedia [PCMM], and so on) and appliances (firewall, deep packet inspection [DPI], and Network Address Translation [NAT]).

Thus the network will be a mix of hardware-based platforms and virtualized solutions, some or all of which will be under SDN control.

### 6.1.1 Network Based on SDN and NVF

[Figure 4](#) shows a framework in which SDN, NFV, and physical components are used to create a flexible solution for cable operators.

The components of the solution are:

- **Applications:** This refers to applications that manage or use the network. They could be customer applications, cable operator applications, or third-party applications. Targeted applications for specific vertical business markets such as hospitality, education, or healthcare would be created here.



- Evolved services platform (ESP):** This layer consists of the elements needed to control and orchestrate the network, data centers, and virtual machines to support SDN and NFV use cases. It consists of tools, technologies, and protocols for centralized intelligence to control, provide network abstraction, and program network infrastructure such that the end user's experience can be orchestrated and controlled, and the network can be automated and optimized. This layer is likely to be made up of software from multiple sources, including open source (for example, Open Daylight [ODL]), vendor, and service provider-written applications. Support for services such as virtual networks and multiple tenants would typically be implemented at this layer.
- Evolved programmable network (EPN):** The programmable network layer is composed of both virtual (NFV) and physical networking platforms. These include the standard transport, switching, and routing equipment used for packet forwarding and also higher layer appliances such as firewalls and NATs. In a cable environment this layer includes the CMTS and EQAM devices, whether implemented as virtual or physical devices. These devices may be standalone or controlled via SDN by a centralized controller (hence programmable network).

**Figure 4.** Cisco SDN Solution for Service Providers

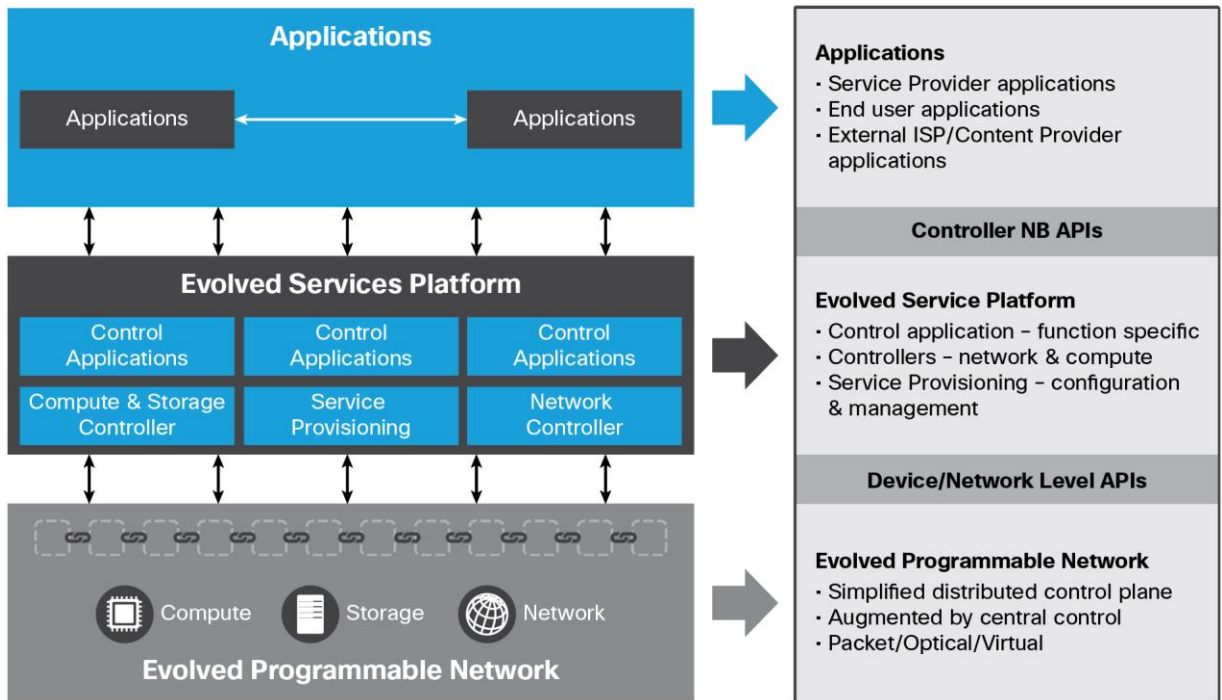

The EPN is where CCAP, DOCSIS 3.1, and Remote-PHY components are located. Integration with the cloud, SDN, and NFV functions located in the application and ESP layers is enabled by the controller and device APIs.

## 7. Deployment in a Cable Operator Network

The previous section has defined the delivery infrastructure into three layers: applications, services platform, and programmable network.

The cable operator network can be conveniently represented as having four potential locations where we could deploy these service components:

- Headend/data center
- Distribution hub
- Optical node
- Customer premises

[Figure 5](#) shows how this infrastructure can be mapped into a cable operator-specific architecture.

**Figure 5.** Mapping SDN and NFV to Cable Operator Network

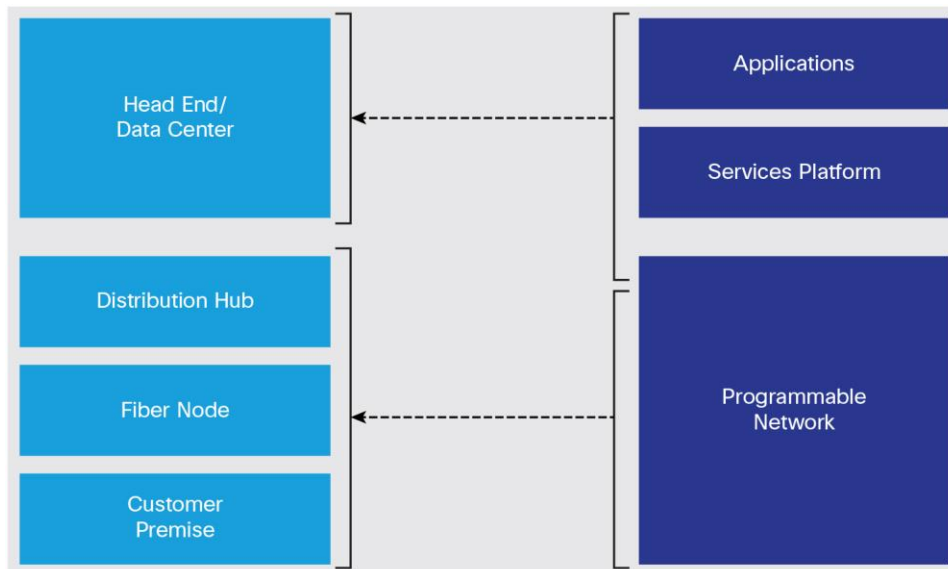

The applications and the evolved services platform components run in a virtualized data center environment and so map very obviously to the headend/data center.

The programmable network layer will be composed of both virtual and physical components. With the deployment of Remote-PHY, the network from the core to the node becomes a digital IP network so that the EPN components could be located anywhere within this network. As distance limitations are essentially removed from the IP network, the data center could, for example, be located in an existing headend, in a regional data center, or even in a national data center/superheadend. Similarly, the CMTS could be a virtual implementation in the data center or a physical platform in the headend or hub.

The distribution of these components through the network for optimum delivery of both residential and business services is critical for cable operators and is the focus of the following section of this paper.

The convention shown in [Figure 6](#) is used to show the network links in the following deployment diagrams. These links typically reflect only one of several possible options available. For example, Ethernet can often be replaced by IP/MPLS or vice versa.

**Figure 6.** Deployment Diagram Key

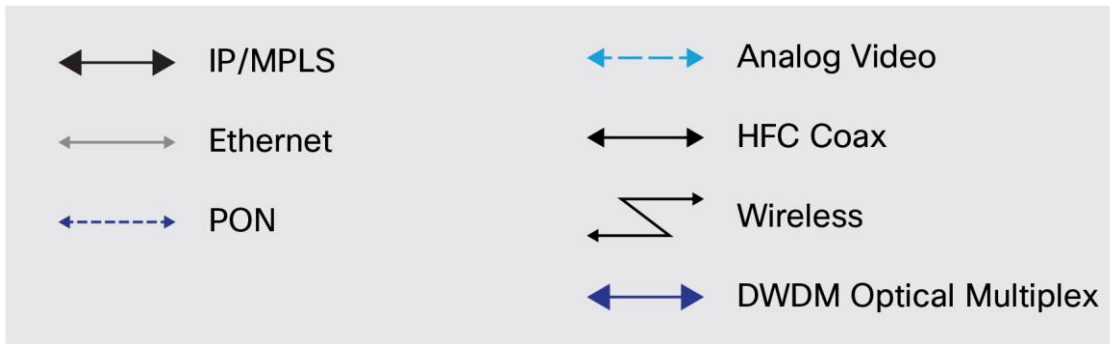

## 7.1 Current Network

[Figure 7](#) shows a typical cable operator network as currently deployed with broadcast services delivered from the headend and narrowcast services injected at the distribution hub.

The distribution hub can be seen to be a critical location where conversion from digital to analog takes place for video and DOCSIS services. The CMTS and EQAM platforms are typically located here because of analog distance limitations. Business services are also shown deployed from the hub based on Ethernet or passive optical network (PON) over fiber. For PON the optical line terminals (OLTs) would be located here because of optical budget limits. Business services may be delivered directly from the hub to the business location or, where possible, share the same fiber path to the node used for residential services. In this case they can either use separate fibers in the bundle or use dense wave-division multiplexing (DWDM). Note that with the exception of business services over DOCSIS (BSoD), the networks for residential and business services (shown in light blue) are essentially separate in this scenario.

Residential services are based on traditional RF nodes, which perform conversion from RF over optics to RF over coax. Business service “nodes” are Ethernet switches or PON optical splitters and combiners.

**Figure 7.** Current Cable Operator Network Deployment

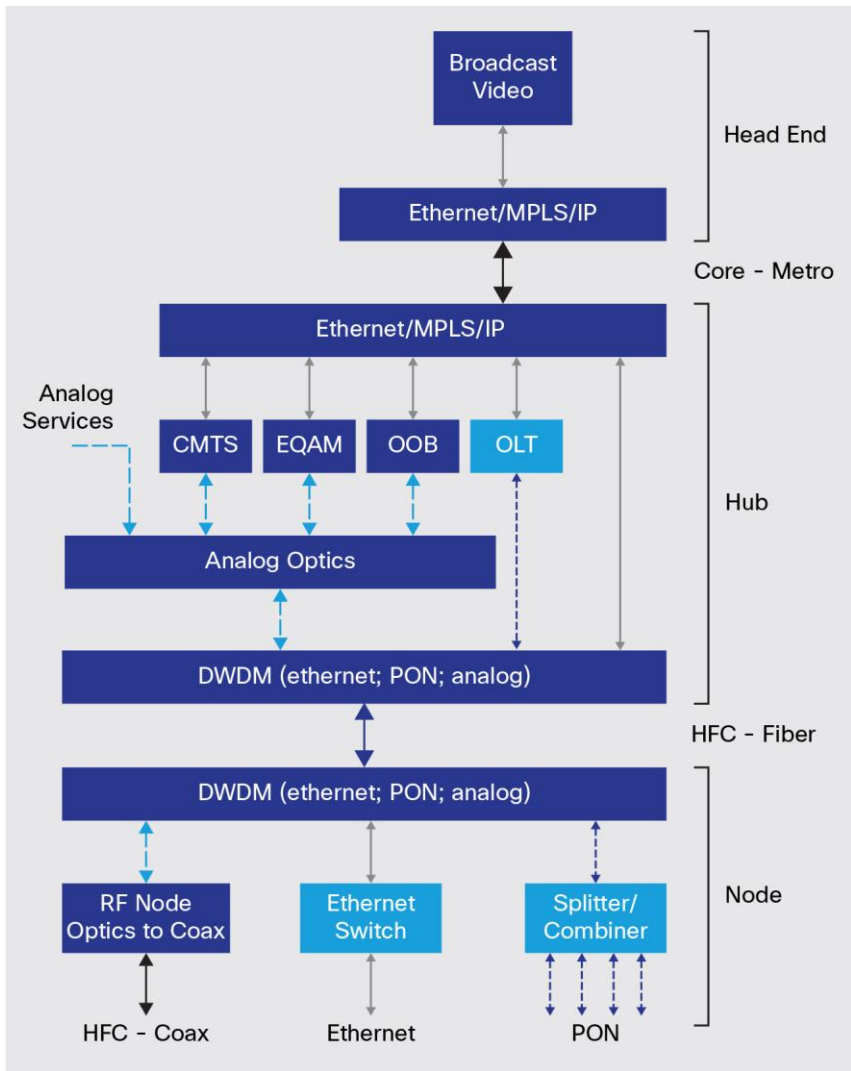

## 7.2 End Goal Deployment

[Figure 8](#) shows a cable operator network in which full advantage has been taken of technical advances in both general service provider and cable operator-specific areas.

**Figure 8.** Cable Operator End Goal Deployment

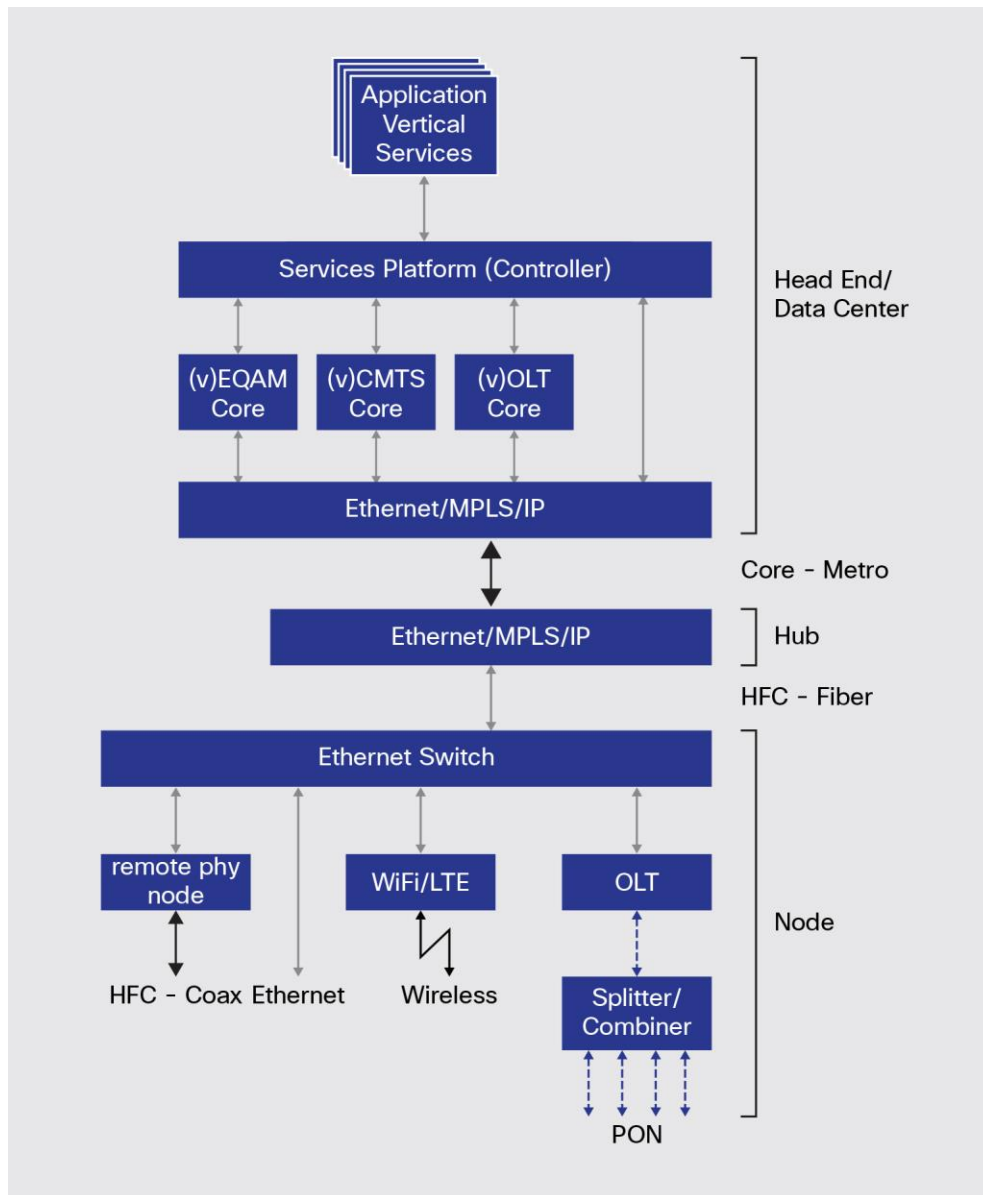

The data center hosts the application layers. Services for targeted verticals such as healthcare, education, and real estate can be created alongside more generic cable operator-generated applications and third-party and customer-created offerings. These applications are able to make use of the virtual compute, storage, and networking features provided by the services platform to execute in a sandbox environment, making sure of application independence, isolation, and security.

---

The services platform provides the control and orchestration facilities to the applications. It provides configuration and management; tools to program the virtual and physical network components; and a centralized, intelligent view of the end-to-end network. It would typically be built on top of a standard SDN controller platform such as Open Daylight.

CMTS, video EQAM, and OLT functions have been split into core components running in the data center and physical layer functions running in the node based on the Remote-PHY architecture. The Remote-PHY component in the node provides the DOCSIS and MPEG video physical layer functions, while a remote OLT provides the lowest layers for a PON network. The core components may be implemented as either physical or virtual devices. In this case virtual implementations are shown running under the virtual network infrastructure of the programmable network. The traffic from and to the virtual and physical components is delivered to and from the core/metro network using standard IP networking technology.

The distribution hub has undergone a dramatic simplification. RF-centric functions have been removed, leaving the hub to become a simple IP/Ethernet distribution point between the metro network and the access network. The former HFC fiber has been repurposed to deliver IP/Ethernet over digital optics.

The node is shown as providing multiple interfaces toward the user, including DOCSIS and MPEG video over coax, switched Ethernet and PON over fiber, and Wi-Fi and long-term evolution (4G cellular) (LTE) wireless links. Obviously a single node need not, and typically will not, provide all of these options, but it is important to note that the IP/Ethernet-based architecture and the embedded Ethernet switch in the node enable this flexibility.

### 7.3 Transition

The transition from the current network shown in [Figure 7](#) toward the ultimate goal shown in [Figure 8](#) will be different for each operator based on local conditions, competition, and available capital and expertise. The paper will not try to capture all the possible options, but there are two major transitions operating in parallel, which then combine to create maximum value:

- Replacement of the RF output from the CCAP platform with digital Ethernet enables relocation of the CMTS/EQAM core out of the hub to a headend or remote data center. This then further enables the move toward NFV implementation of these components, facilitates the use of the orchestration and control services, and encourages the SDN transition.
- The replacement of analog with digital transmission between the hub and the node enables the sharing of these links between residential and business services and provides the capability to deliver multiple access networks (coax, fiber, wireless) from the hub based on a common network infrastructure. In effect, this enables the IP/Ethernet network to be extended from the core to the node.

In the real world these transitions will not be aligned in time. [Figure 9](#) shows a potential first step in which transition 1 has occurred for data. The CMTS core has been displaced to the data center, but video EQAMs remain in the hub, and the hub-to-node infrastructure has not yet been updated.

**Figure 9.** Transitional Deployment Option

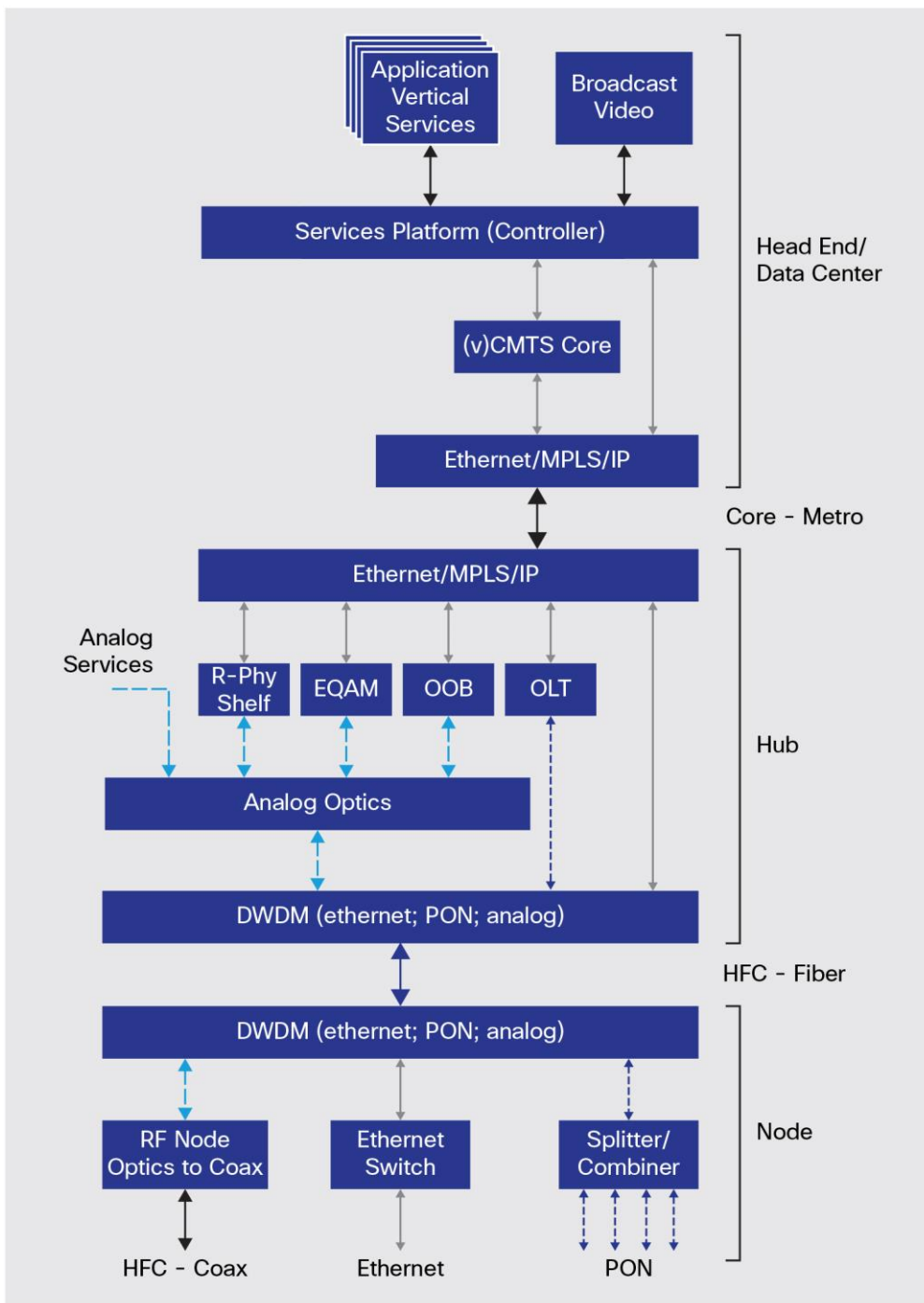

The enabler for this step is the Remote-PHY shelf, which is introduced into the hub with the CMTS core moved to the data center. The shelf provides the same DOCSIS functions as the Remote-PHY node and has the same interface to the CMTS core. It converts the DOCSIS over Ethernet into RF and integrates this with the existing combining and optical transmission system in the hub for delivery to the node.

---

Thus the SDN and NFV transition can take place without requiring the digital hub-to-node transition and is not predicated on the integration of data and video, which can follow in later phases.

## 8. Service Effects

The southbound interfaces from the node shown in [Figure 8](#) can be used for a mix of residential and business services. The network architecture has moved from parallel business service and residential networks to a shared infrastructure. Both business service and residential applications are built on the virtualized infrastructure in the data center, sharing the same compute, storage, and networking resources. They use the same operational and orchestration tools provided by the control services platform and run on top of the same programmable network components.

The following use cases provide some examples in the areas of optimization, orchestration, and traffic management to illustrate how the SDN and NFV paradigms can be combined with enhancements to the cable network to change the way cable operators provide services.

### 8.1 SDN-Related Service Effects

#### 8.1.1 Network Optimization

One of the benefits of a centralized SDN control model is that it can take a holistic view of the infrastructure and the traffic demands on that infrastructure. The following examples show how this can be applied to service delivery in a cable operator environment:

- **Multilayer optimization:** Through knowledge of the traffic demands on the packet network topology and the optical topology, an SDN control element is able to compute a dynamically coupled packet and optical topology that addresses the traffic demands in an optimal fashion. This can be applied to the core and regional components of today's cable operator networks and, with the extension of the IP network to the node as Remote-PHY is deployed, can also be used to orchestrate node-to-CMTS mapping.
- **Demand engineering:** This is associated with the optimal placement of entities that produce network traffic such as video servers and CDN caches so that they meet their SLA and allow the network to operate in the most efficient manner.
- **Bandwidth calendaring:** Some business service customers need to move large, predictable amounts of data around the network at specific times. The bandwidth calendaring solution needs a view of the physical network topology and the expected bandwidth usage at the time of the transfer. It then performs an admission control function and potentially adjusts the logical structure of the network to accommodate the bandwidth request. This can also be applied to optimize internal data transfers such as populating CDN caches and video streamers.

#### 8.1.2 Network Orchestration and Traffic Management

The evolved services platform can be used to orchestrate services and the network in order to deliver services more efficiently, as shown in the following use cases:

- **Cloud orchestration (infrastructure as a service [IaaS]):** Cable operators can deliver complete orchestrated infrastructure solutions to business customers. An SDN controller can build the virtual network infrastructure that connects the virtual machines and storage and programs the network to provide the necessary connectivity.



- 
- **Automated installation and configuration:** This refers to a scenario where aggregation and access devices automatically configure themselves. This is particularly important at the edge of the network, because there are potentially thousands of devices being installed by unskilled or semiskilled personnel. In this use case, the newly installed device is detected, authenticated, and loaded with the correct base configuration. This scenario is clearly important for both business and residential services, especially as the network migrates to a Remote-PHY architecture.
  - **Automated service activation:** In this case, the end-user service is automatically configured based on the edge device detecting a “first sign of life” and the appropriate service configuration being installed. The sign of life could be a VLAN becoming active or a protocol, such as DHCP or Point to Point Protocol over Ethernet (PPPoE), starting its handshaking procedures. This has application to both business and residential service deployment.
  - **Flow classification and redirection:** End users are identified when they become active on the access gateway. Through the use of a central policy server, the traffic is classified, and part or all of the traffic can be redirected to a set of services based on the received policy. Examples of such services include Transmission Control Protocol (TCP) optimization, video optimization, firewalling, and NAT.

## 8.2 NFV-Related Service Effects

### 8.2.1 Virtualized Services

The service architecture for business and residential customers, supporting functions such as firewalling, optimization, NAT and so on, is currently built around standalone appliances. This deployment model leads to little flexibility, limited scaling, and potential capacity mismatches. This entire infrastructure can be transitioned to an NFV-based solution through the use of virtualization and service-chaining technology so that customers can receive a customized service set.

### 8.2.2 Service Provider Platforms

This includes applications such as video infrastructure and web servers and network control elements such as DHCP and Domain Name System (DNS) servers. These systems provide the critical infrastructure needed to run the network and can benefit from virtualization in the same way as customer services.

### 8.2.3 Virtual CPE

Virtualization of the CPE can reduce the cost and complexity of the deployed CPE by supporting more of the functionality in the data center. Thus the customer premises device could be replaced with a simpler Layer 2 access device with the Layer 3 and above service functions moved to the data center. This simplifies operations and has the benefit of not requiring CPE upgrades each time new services are deployed.

## 8.3 Risks, Benefits, and Conclusions

Cable operators are facing a changing business environment, along with disruptive technologies in how services and networks are built. NFV and SDN are innovations that combine the benefits of the network and the cloud. If used correctly, they can significantly reduce the total cost of ownership and improve time to market and time to revenue for cable operator-provided services. Thus there are pressing reasons for cable operators to move in this direction.

The deployment of CCAP, deep fiber, and Remote-PHY devices will provide the bandwidth and the “IP to the edge” network that operators will need to get the maximum use from the new technology. The combination of these cable-specific changes with SDN and NFV can provide a multiplier effect to the cost-effectiveness and flexibility of cable operator service delivery.

There are risks and challenges inherent in moving to any new services model, and the move toward Remote-PHY, SDN, and NFV will not be an exception to this. Changes to the process by which networks are designed, built, and operated will be needed, along with changes to the organizational and operational model and the skill sets required. In addition to running the current network, it will become necessary to support the virtualized data center environments on which the SDN platforms and VNFs execute and to closely integrate these with the physical network. In addition, a transition strategy will be required to introduce the new technologies with minimum service and operational disruption.

As this paper shows, cable operators can use SDN and NFV along with the CCAP and Remote-PHY to deliver services more effectively and can construct a viable transition strategy to reach this desired virtualized positive state using a series of manageable stages.

## References

Table 1 lists references cited in this paper.

**Table 1.** References

Reference Topics	Reference Links
CCAP	<a href="http://www.cablelabs.com/specification/ccap-architecture-technical-report/openflow">http://www.cablelabs.com/specification/ccap-architecture-technical-report/openflow</a>
Cisco VNI 2013	<a href="http://www.ciscovni.com/index.html">http://www.ciscovni.com/index.html</a>
CL DOC31	<a href="http://www.cablelabs.com/specification/mac-and-upper-layer-protocols-interface-specification/">http://www.cablelabs.com/specification/mac-and-upper-layer-protocols-interface-specification/</a>
ETSI NFV	<a href="http://portal.etsi.org/portal/server.pt/community/NFV/367">http://portal.etsi.org/portal/server.pt/community/NFV/367</a>
ODL	<a href="http://www.opendaylight.org">http://www.opendaylight.org</a>
ONF ORG	<a href="https://www.opennetworking.org">https://www.opennetworking.org</a>
ONF SDN	<a href="https://www.opennetworking.org/sdn-resources/sdn-definition">https://www.opennetworking.org/sdn-resources/sdn-definition</a>
OPENFL	<a href="https://www.opennetworking.org/sdn-resources/onf-specifications/openflow">https://www.opennetworking.org/sdn-resources/onf-specifications/openflow</a>



Americas Headquarters  
Cisco Systems, Inc.  
San Jose, CA

Asia Pacific Headquarters  
Cisco Systems (USA) Pte. Ltd.  
Singapore

Europe Headquarters  
Cisco Systems International BV Amsterdam,  
The Netherlands

Cisco has more than 200 offices worldwide. Addresses, phone numbers, and fax numbers are listed on the Cisco Website at [www.cisco.com/go/offices](http://www.cisco.com/go/offices).

Cisco and the Cisco logo are trademarks or registered trademarks of Cisco and/or its affiliates in the U.S. and other countries. To view a list of Cisco trademarks, go to this URL: [www.cisco.com/go/trademarks](http://www.cisco.com/go/trademarks). Third party trademarks mentioned are the property of their respective owners. The use of the word partner does not imply a partnership relationship between Cisco and any other company. (1110R)