

# Cisco Multimedia Line Equalizer/Reverse Conditioner 1 GHz - 85/105 MHz Split

The Cisco® Multimedia Line Equalizer/Reverse Conditioner (LEQ/RC), shown in Figure 1, improves network performance on both the forward and reverse paths in a coaxial transmission system.

In the forward path, the fixed forward equalizer offsets undesirable down-tilt associated with cumulative cable and passive losses, allowing tap port RF levels to be maintained within desired design limits, even at taps located near the ends of lines.

In the reverse path, plug-in attenuation allows RF levels to be conditioned for optimal performance of critical reverse path services. By selectively adding reverse attenuation at Cisco Multimedia LEQ/RC locations, the range of RF levels transmitted from closed-loop customer premises equipment in a given service area can be narrowed considerably.

With greater percentages of devices, such as high-speed data and telephony modems, transmitting in the upper end of their RF transmit ranges, improvements in carrier-to-ingress and carrier-to-noise performance can be realized.

**Figure 1.** Cisco Multimedia Line Equalizer/Reverse Conditioner



## Features

- Fixed 9 dB or 11 dB forward equalizers
- Plug-in attenuator location for reverse-path optimization
- Connection beam non-interruptible AC and RF bypass (Figure 2) that optimizes network availability during maintenance periods
- Equalizer in and out bypass, which allows reverse conditioning deployment network locations where forward equalization is not desired

- 15A current passing capability, which allows placement in all portions of the network
- 6 kV surge protection
- Circuit contained in faceplate, compatible with existing Cisco line equalizer products
- Rugged, polymer-coated housing that provides reliable performance in the most challenging environments; additional labels provided in packaging mark the tap containing a DC/EQ module

**Figure 2.** Block Diagram

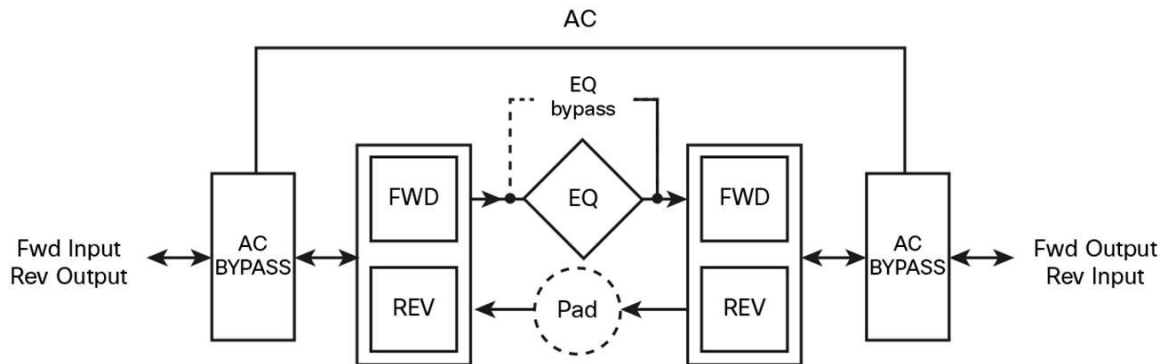

## Product Specifications

Tables 1 through 7 provide product specifications.

**Table 1.** Insertion Loss

Insertion Loss						
Frequency	Bypass Mode		Equalization Mode			
			9 dB		11 dB	
	Typical	Maximum	Typical	Maximum	Typical	Maximum
5 MHz	-0.5 dB	-1.0 dB	-0.5 dB	-1.0 dB	-0.5 dB	-1.0 dB
10 MHz	-0.4 dB	-1.0 dB	-0.4 dB	-1.0 dB	-0.4 dB	-1.0 dB
40 MHz	-0.7 dB	-1.0 dB	-0.7 dB	-1.0 dB	-0.7 dB	-1.0 dB
50 MHz	-0.9 dB	-1.0 dB	-0.9 dB	-1.0 dB	-0.9 dB	-1.0 dB
85 MHz	-1.0 dB	-1.3 dB	-1.0 dB	-1.3 dB	-1.0 dB	-1.3 dB
105 MHz	-1.1 dB	-1.3 dB	-7.9 dB	-8.5 dB	-10.8 dB	-11.5 dB
450 MHz	-0.9 dB	-1.3 dB	-5.5 dB	-5.8 dB	-5.9 dB	-6.7 dB
550 MHz	-1.0 dB	-1.4 dB	-4.5 dB	-5.1 dB	-4.8 dB	-5.8 dB
650 MHz	-1.0 dB	-1.7 dB	-3.7 dB	-4.5 dB	-4.0 dB	-5.0 dB
750 MHz	-1.1 dB	-1.8 dB	-3.1 dB	-3.9 dB	-3.3 dB	-4.3 dB
870 MHz	-1.4 dB	-2.0 dB	-2.3 dB	-3.2 dB	-2.7 dB	-3.5 dB
1000 MHz	-1.9 dB	-2.2 dB	-2.2 dB	-2.5 dB	-2.3 dB	-2.5 dB

**Table 2.** Return Loss

Return Loss						
Frequency	Bypass Mode		Equalization Mode			
			9 dB		11 dB	
	Typical	Minimum	Typical	Minimum	Typical	Minimum
5 to 10 MHz	-16 dB	-15.5	16 dB	-15.5	-16 dB	-15.5
11 to 85 MHz	-18 dB	-16	17 dB	-16	-17 dB	-16
105 to 1000 MHz	-18 dB	-16	17 dB	-16	-17 dB	-16

**Table 3.** Flatness

Flatness						
Frequency	Bypass Mode		Equalization Mode			
			9 dB		11 dB	
	Typical	Maximum	Typical	Maximum	Typical	Maximum
5 to 85 MHz	0.65 dB	0.65 dB	0.65 dB	0.65 dB	0.65 dB	0.65 dB
105 to 1000 MHz	0.75 dB	0.75 dB	0.75 dB	0.75 dB	0.75 dB	0.75 dB

**Table 4.** Group Delay

Group Delay		
Frequency	Typical	Maximum
<b>Forward</b>		
109.25 to 112.83 MHz	15 ns	20 ns
115.25 to 118.83 MHz	7 ns	10 ns
<b>Reverse</b>		
5.0 to 6.5 MHz	40 ns	40 ns
6.5 to 8.0 MHz	20 ns	30 ns
8.0 to 9.5 MHz	9 ns	15 ns
80.5 to 82.0 MHz	9 ns	15 ns
82.0 to 83.5 MHz	8 ns	20 ns
83.5 or 85 MHz	17 ns	30 ns

**Table 5.** Power Passing

Power Passing			
Frequency	Bypass Mode	Equalization Mode	
		9 dB	11 dB
-	15A	15A	15A

**Table 6.** Hum Modulation

Hum Modulation			
Frequency	Bypass Mode	Equalization Mode	
		9 dB	11 dB
5 to 10 MHz	-60 dBc @12A	-60 dBc @12A	-60 dBc @12A
11 to 1000 MHz	-60 dBc @12A	-60 dBc @12A	-60 dBc @12A

**Table 7.** Safety and Compliance

Safety and Compliance	
Items	Specs
<b>EMC</b>	EN50083-2, EN55022 Class A, EN55024 Class A, and FCC Part 76/Part 15
<b>Safety standards</b>	EN/IEC 60065, UL 497, 1459 ,and 1950

**Note:**

1. Chrominance and luminance at 3.58 MHz above the video carrier
2. Propagation delay in 2 MHz bandwidth
3. Unless otherwise noted, all the specifications in Table 1 through Table 7 reflect typical station performance at stated reference levels in the recommended operating configurations. Specifications are based on measurements made in accordance with SCTE/ANSI standards (where applicable), using standard frequency assignments

**Ordering Information**

To place an order, visit the [Cisco Ordering Home Page](#) and refer to Table 8 and Table 9, which list the part numbers for the Cisco Multimedia LEQ/RC.

**Table 8.** Ordering Information

Description	Part Number
Cisco Multimedia LEQ/RC, 85/105 MHz split, 9 dB Forward EQ	4038256
Cisco Multimedia LEQ/RC, 85/105 MHz split, 11 dB Forward EQ	4038257

**Table 9.** Plug-In Attenuators

Value	Part Number	Value	Part Number	Value	Part Number
0 dB	574475	6 dB	574481	12 dB	574487
1 dB	574476	7 dB	574482	13 dB	574488
2 dB	574477	8 dB	574483	14 dB	574489
3 dB	574478	9 dB	574484	15 dB	574490
4 dB	574479	10 dB	574485	75 ohm	574496
5 dB	574480	11 dB	574486		

---

## For More Information

Cisco Multimedia Line Equalizer/Reverse Conditioner products include some of the industry's most complete range of high-performance components. For additional information, please go to:

<http://www.cisco.com/en/US/products/ps9101/index.html>.



---

Americas Headquarters  
Cisco Systems, Inc.  
San Jose, CA

Asia Pacific Headquarters  
Cisco Systems (USA) Pte. Ltd.  
Singapore

Europe Headquarters  
Cisco Systems International BV Amsterdam,  
The Netherlands

Cisco has more than 200 offices worldwide. Addresses, phone numbers, and fax numbers are listed on the Cisco Website at [www.cisco.com/go/offices](http://www.cisco.com/go/offices).

 Cisco and the Cisco logo are trademarks or registered trademarks of Cisco and/or its affiliates in the U.S. and other countries. To view a list of Cisco trademarks, go to this URL: [www.cisco.com/go/trademarks](http://www.cisco.com/go/trademarks). Third party trademarks mentioned are the property of their respective owners. The use of the word partner does not imply a partnership relationship between Cisco and any other company. (1110R)