

Cisco GainMaker 1 GHz High Output 4-Port Node with 85/102 MHz Split

Demand for consumer bandwidth continues to grow at a rapid rate every year. As a result, cable operators with DOCSIS[®]-based equipment have begun introducing fiber deeper and deeper into the network. They want to reduce service group sizes and ultimately double, triple, or quadruple bandwidth speeds. The Cisco[®] GainMaker[®] 1 GHz High Output 4-Port Node is ideal for deep fiber applications. With higher output levels, featuring four high-level RF output ports and a segmentable reverse path, the Cisco GainMaker 1 GHz High Output 4-Port Node is an ideal platform for delivering video (digital and analog) as well as high-speed data services over advanced hybrid fiber-coaxial (HFC) networks.

The Cisco GainMaker 1 GHz High Output 4-Port Node can segment and route reverse traffic to distributed feedback (DFB), coarse wavelength-division multiplexing (CWDM), dense wavelength-division multiplexing (DWDM), or Enhanced Digital Reverse (EDR) transmitters. The module is available with an optional DOCSIS status-monitoring transponder for use with all HMS-compliant monitoring and control element management systems. It can also monitor onboard temperature, RF switch position (wink switch), and power supply condition, as well as other features and parameters.

Installation of the Cisco GainMaker 1 GHz High Output 4-Port Node is quick and easy. The fiber receiver is delivered with pre-connectorized fiber terminations. The optional pre-connectorized cable stub is the ideal method for connecting the Cisco GainMaker 1 GHz Node to the fiber network. The Cisco GainMaker 1 GHz Node includes a 4-fiber handling tray for these cables.

Figure 1. Cisco GainMaker 1 GHz High Output 4-Port Node with 85/105 MHz Split

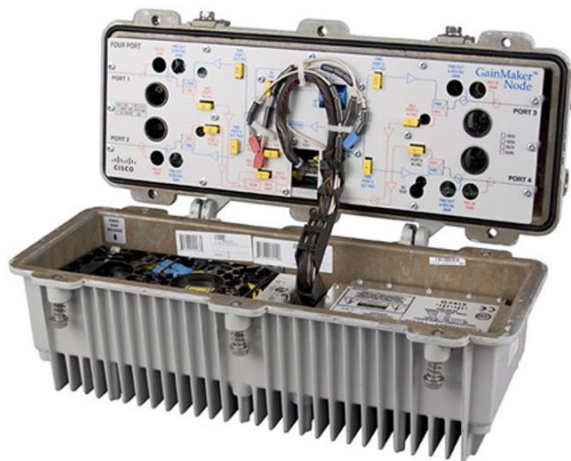

Features

- Uses plug-in accessories common to all Cisco GainMaker nodes and GS7000 products (attenuator pads, equalizers, diplexers, and crowbar)
- Reverse segmentation with two analog DFB, CWDM, or DWDM reverse transmitters
- Reverse segmentation with two 1:1 EDR transmitters
- Supports one 2:1 EDR transmitter (occupies two transmitter slots)
- Interstage equalizer (ISEQ) provides 14.5 dB of linear tilt
- Amplifier cover provides access to RF test points
- Two optical transmitter positions in the lid
- One optical receiver position in the lid
- Optional DOCSIS status monitoring plug-in transponder
- Optional reverse redundancy option; two reverse transmitters (one in “hot standby”) available for the nonsegmented node case
- Fiber management tray provides easy access to fiber connections and folds back to provide access to optical transmitter and receivers
- Power supply mounted in housing lid for efficient thermal dissipation (60V and 90V AC powering capability)
- Reverse input pad and RF test point for each reverse input port on Cisco GainMaker launch amplifier allow optimum reverse path design and alignment
- Optional dual redundant receiver provides ability to switch to redundant optical power in case of fiber cut
- Quadrature amplitude modulation (QAM) and analog pilot automatic gain control (AGC) available (optional)
- AGC has thermal backup, which eliminates disruptive RF output variation in the event of pilot loss
- Local test points and LED indicators on optical receivers, transmitters, and optical interface board simplify installation and maintenance
- Integrated three-state reverse switch (on/off/-6 dB) allows each reverse input to be isolated for noise and ingress troubleshooting (status monitoring required)
- Surge-resistant circuitry helps ensure gain stage protection without fuses or other nuisance-failure-causing devices

Block Diagrams

Figures 2 through 5 provide block diagrams of configuration options for the Cisco GainMaker 1 GHz High Output 4-Port Node.

Figure 2. Combined Reverse Path with Redundant Transmitter Block Diagram

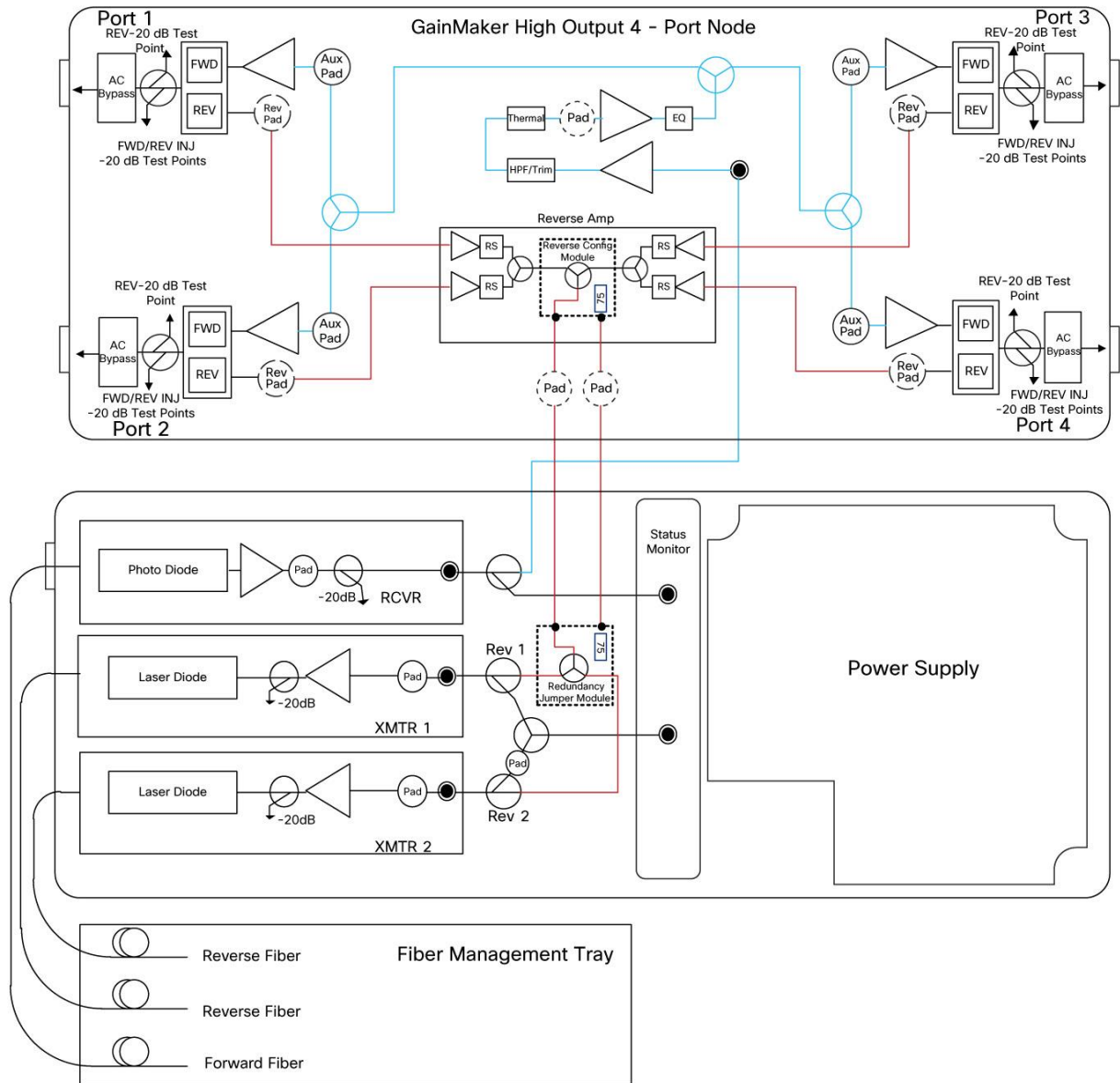

Figure 3. Segmented Reverse Path Block Diagram

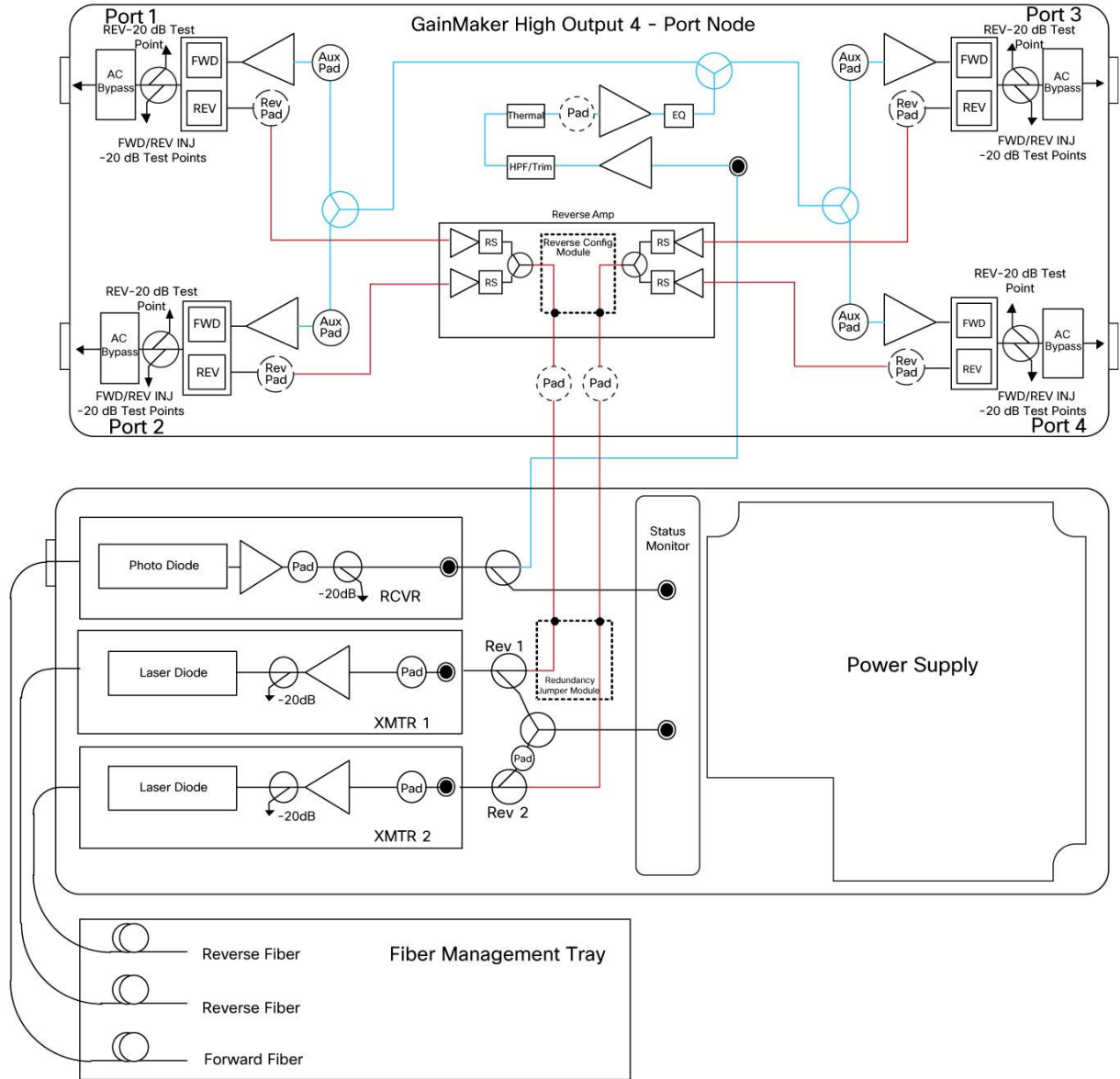

Figure 4. Dual Redundant Receiver Block Diagram

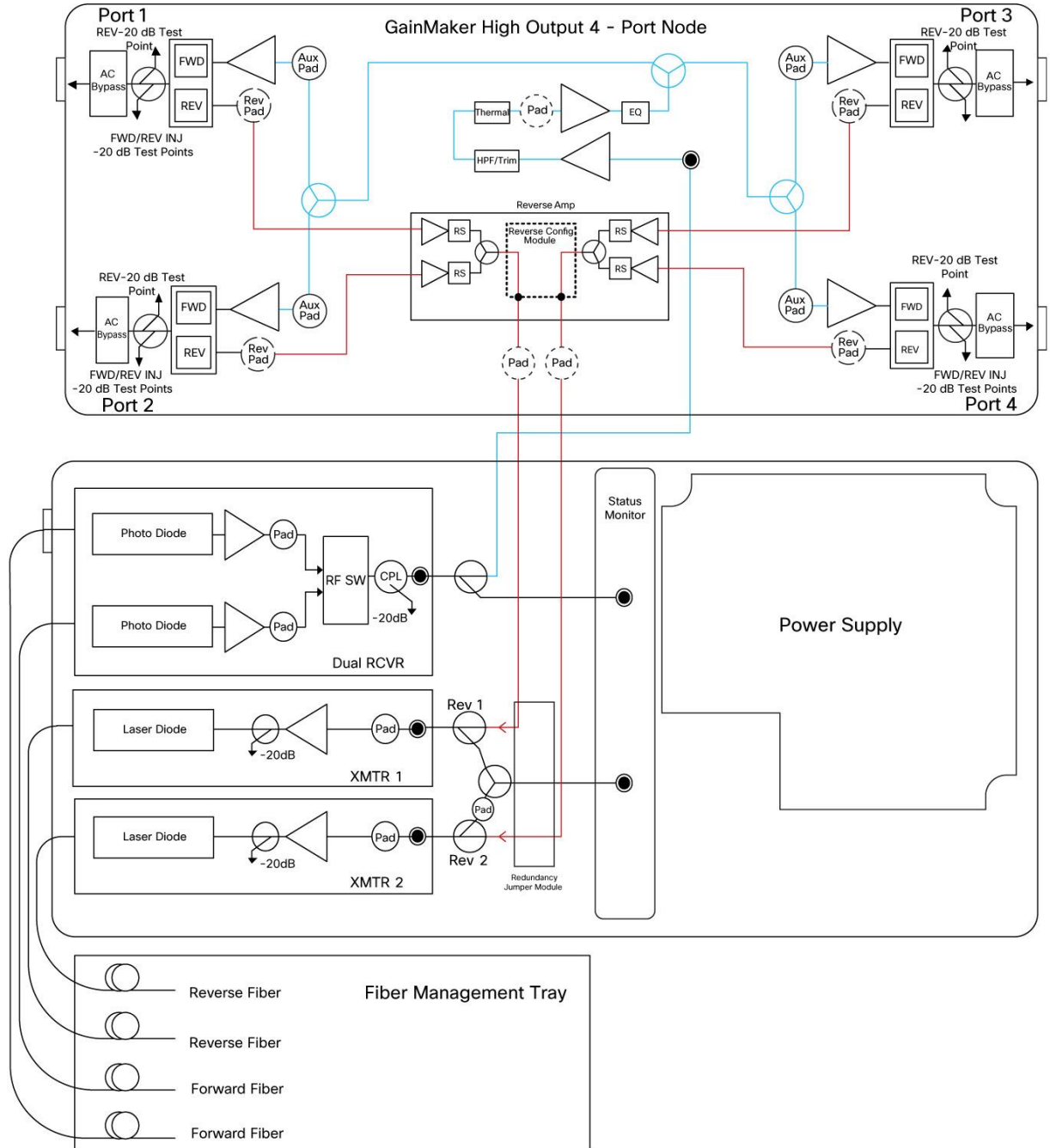
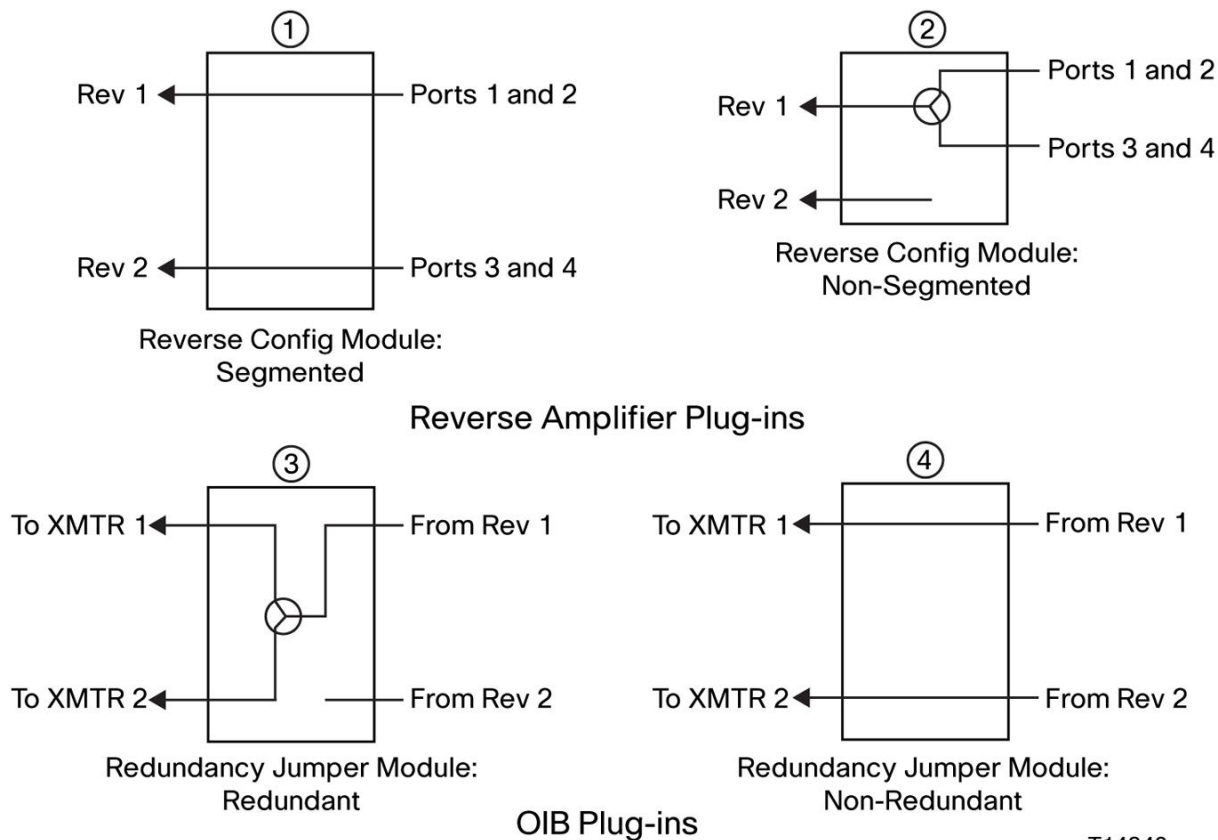

Figure 5. Configuration Module Block Diagram



T14849

Table 1 lists all possible reverse amplifier plug-in and optical interface board (OIB) plug-in combinations. Each circled number references the plug-ins shown in Figure 5.

Table 1. Reverse Amplifier and Optical Interface Board Plug-in Combinations

Transmitters	Reverse Amplifier Plug-In	OIB Plug-In
Segmented XMTRS (nonredundant)	①	④
Redundant XMTR (nonsegmented)	②	③
Nonsegmented and nonredundant	②	④

Optical Specifications

Table 2 lists optical section specifications for the forward receiver module, and Figure 6 compares receiver RF output levels with the transmitter Optical Modulation Index (OMI). The notes following Figure 6 also apply to Table 2.

Table 2. Optical Section

Optical Section: Forward Receiver Module	Units	GainMaker Standard RX	Notes
Wavelength	nm	1310 and 1550	
Optical input range	mW dBm	0.5-1.6 -3 -+2	
Pass band	MHz	52-1002	
Frequency response	dB	± 0.75	1
Tilt (±1.0 dB)	dB	0	
Optical input test point (±10%)	VDC	1V per mW	
RF output level at 0 dBm optical input	dBmV	Refer to Figure 6	2
RF output test point (±1.0 dB)	dB	-20	

Figure 6. Receiver RF Output Level and Transmitter OMI

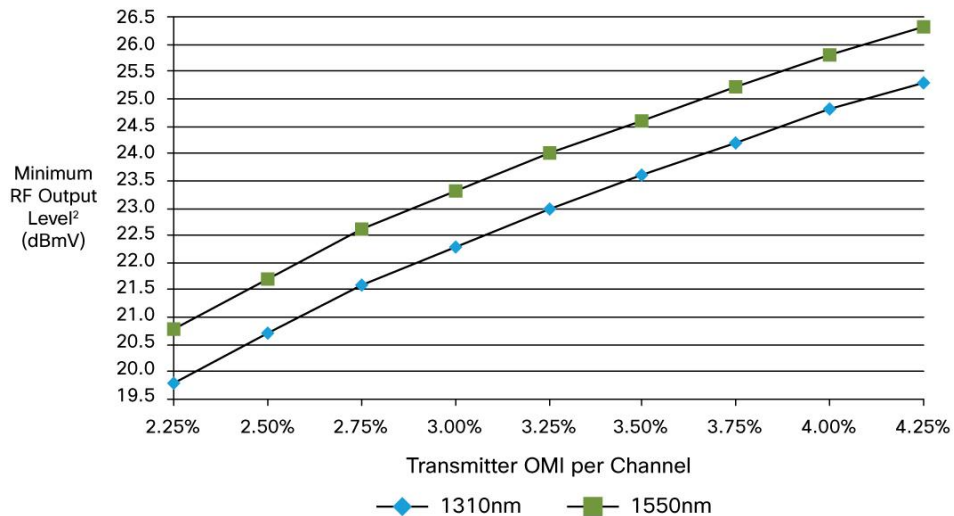

Notes:

1. For forward receiver module only. Does not include frequency response contributions from forward optical transmitter.
2. Minimum receiver RF output level for the stated transmitter percent OMI per channel, with receiver optical input power of 0 dBm. To determine RF output levels at other optical input power levels, add (or subtract) 2 dB in RF level for each 1 dB increase (or decrease) in receiver optical input power.

For reverse optical transmitter and link performance, see the "Analog Reverse Optical Transmitters for Model 6940/6944 and GainMaker Optoelectronic Stations" data sheet, part number 750874.

Unless otherwise noted, specifications reflect typical performance and are referenced to 68°F (20°C). Specifications are based upon measurements made in accordance with SCTE/ANSI standards (where applicable), using standard frequency assignments.

Other Product Specifications

Tables 3 through 9 provide additional specifications for the Cisco GainMaker 1 GHz High Output 4-Port Node with 85/105 MHz Split.

Table 3. RF Section Specifications

General Station Performance	Units	Forward	Reverse	Notes
Pass band	MHz	105-1002	5-85	8
Return loss	dB	16	16	
Hum modulation at 12A	dB	70 (105-870 MHz) 60 (870-1002 MHz)	60 (5-10 MHz) 70 (11-85 MHz)	
Hum modulation at 15A	dB	65 (105-870 MHz) 60 (870-1002 MHz)	60 (5-10 MHz) 65 (11-85 MHz)	
Test points (± 0.5 dB)	dB	-20	-20	

Table 4. Launch Amplifier Performance: Forward

Launch Amplifier Performance: Forward	Units	GainMaker 4-Port	Notes
Operational gain (minimum)	dB	41	8
Frequency response	dB	± 0.5	
Internal tilt (± 1 dB)	dB	13.8	1, 2
Noise figure at:	dB	8.5	
105 MHz		8.0	
1002 MHz			
Reference output levels at:	dBmV	56.0	
1002 MHz		54.0	
870 MHz		52.2	
750 MHz		50.5	
650 MHz		49.0	
550 MHz		41.5	
105 MHz			
Reference output tilt (55-1002 MHz)	dB	13.7	1, 3
78 NTSC channels (CW) with digital			5
Composite triple beat	dB	65	4
Cross modulation	dB	59	4, 6
Composite second order (high side)	dB	64	4
Composite intermodulation noise (CIN)	dB	57	4, 7

Notes:

- Reference output tilt and internal tilt are both "linear" tilts.
- Forward internal tilt specified is primarily due to an on-board equalizer and a factory-configured linear interstage equalizer (ISEQ).
- The forward reference output tilt specified is achieved through field installation of an appropriate input equalizer, in conjunction with the internal tilt of the launch amplifier and the tilt associated with the optical link (transmitter and receiver combination).
- Station performance can be determined by combining optic performance and launch amplifier performance. Stated distortion performance is for launch amplifier section operated at reference output levels and tilt.
- "Digital" refers to 550 to 1002 MHz loading with QAM carriers at -6 dB relative to analog video carrier levels.
- X-mod (at 15.75 kHz) is specified using 100 percent synchronous modulation and frequency-selective measurement device.
- Composite intermodulation noise (CIN) is a broadband noise like distortion product associated with QAM loading.
- The gain at 102 MHz is < 1.5 dB below the gain at 105 MHz. 102 to 105 MHz is recommended for out-of-band communication only. No video carriers should be used between 102 and 105 MHz.

Unless otherwise noted, specifications reflect typical performance and are referenced to 68°F (20°C). Specifications are based upon measurements made in accordance with SCTE/ANSI standards (where applicable), using standard frequency assignments.

Table 5. Launch Amplifier Performance: Reverse

Reverse Station Performance	Units	Reverse	Notes
Amplifier type	-	GaAs FET	
Operational gain (minimum)	dB	-2	1, 2
Frequency response	dB	±0.5	
Internal tilt (±1 dB)	dB	0	
Path-to-path isolation	dB	50	
Noise figure	dB	13.5	2

Notes:

- Reverse operational gain is measured from the reverse RF input port to the RF input to the reverse transmitter and includes optical interface board losses.
- Reverse gain and noise figure for launch amplifier with 0 dB reverse input pad and 0 dB output pad.

Table 6. RF Delay Specifications

Station Delay Characteristics			
Forward (Chrominance to Luminance Delay)		Reverse (Group Delay in 1.5 MHz BW)	
Frequency (MHz)	Delay (ns)	Frequency (MHz)	Delay (ns)
109.25 - 112.83	8	5.0 - 6.5	33
115.25 - 118.83	5	6.5 - 8.0	15
121.25 - 124.83	4	8.0 - 9.5	8
		80.5 - 82.0	5
		82.0 - 83.5	7
		83.5 - 85.0	10

Table 7. Electrical Specifications

Electrical	Units	Value			Notes
Maximum AC through current (continuous)	A	15			
Maximum AC through current (surge)	A	25			
Component DC Power Consumption (Typical)		at +24 VDC	at +15 VDC	at -6 VDC	1
Launch amplifier	A	2.60			
Status monitoring transponder	A	0.15			
Standard optical receiver	A	0.25	0.01	0.035	
Reverse transmitter: high-gain FP	A	0.09	-	0.07	
Reverse transmitter: high-gain DFB	A	0.11	-	0.09	
Power supply DC current rating	A	3.5	0.05	0.35	1

Note:

- The total DC power consumption of installed components should not exceed the power supply's DC current rating.

Unless otherwise noted, specifications reflect typical performance and are referenced to 68°F (20°C). Specifications are based upon measurements made in accordance with SCTE/ANSI standards (where applicable), using standard frequency assignments.

Table 8. Electrical Specifications

GainMaker 4-Port Node, 2 Transmitters, 1 Receiver, 1 Status Monitor, 1 Launch Amplifier						
DC current	24 VDC at 3.2A, 15 VDC at 0.01A, and -6 VDC at 0.215A					
AC voltage	90	80	70	60	50	40
AC current (A)	1.21	1.26	1.45	1.69	1.97	2.47
AC power (W)	92.31	91.67	90.91	90.49	90.22	90.5

Table 9. Environmental and Mechanical Specifications

Environmental	Units	Value
Operating temperature range	°F and °C	-40 to 140°F (-40 to 60°C)
Relative humidity range	%	5% to 95%
Mechanical		
Housing dimensions (L x H x D)	in. and mm	17.6 in. x 7.5 in. x 7.9 in. (447 mm x 191 mm x 201 mm)
Weight (station with 1 RX, 1 TX, and power supply)	lb and kg	22.5 lb (10.2 kg)

Ordering Information

The Cisco GainMaker 1 GHz High Output 4-Port Node is available in a wide variety of configurations. The desired configuration is “built” by accessing the Cisco Commerce Workspace tool at <https://cisco-apps.cisco.com/cisco/psn/commerce>. The user specifies the new assemble-to-order (ATO) product ID for the Cisco GainMaker 1 GHz High Output 4-Port Node “GMN-4PORT,” and the tool steps through the available options. Services may also be selected during this process. Once all the desired options are selected, the configuration and price are displayed. After you click the “Done” radio button, you can export and save the configuration for future use or immediate ordering.

Table 10 contains ordering information for required and optional accessories. Please consult with your account representative, customer service representative, or applications engineer to determine the best configuration for your particular application.

Table 10. Required Accessories

Required Accessories for RF Module	Part Number
Plug-in pads (attenuators): available in 0.5-dB steps from 0 to 20 dB <ul style="list-style-type: none"> 1 required for interstage (if 0 dB value installed in the node when shipped does not fit the system design) 6 required for reverse (4 input, 2 output) 	589693 (0 dB) sequentially through 589734 (20.5 dB)
Plug-in forward linear equalizer: available in 1.5-dB steps from 0 to 30 dB at 1002 MHz <ul style="list-style-type: none"> 1 required for forward input 	See Table 11

Unless otherwise noted, specifications reflect typical performance and are referenced to 68°F (20°C). Specifications are based upon measurements made in accordance with SCTE/ANSI standards (where applicable), using standard frequency assignments.

Required Accessories for Optical Components	Part Number
Plug-in pads (attenuators): available in 0.5-dB steps from 0 to 20.5 dB <ul style="list-style-type: none"> • 1 each required for transmitter and receiver(s) 	279500 (0 dB) sequentially through 279513 (13 dB) in 1-dB steps
	504151 (14 dB) sequentially through 504157 (20 dB) in 1-dB steps
	565231 (0.5 dB) sequentially through 565251 (20.5 dB) in 1-dB steps

Note: Configured nodes ship without reverse input pads and without forward input pads or equalizer. All other accessories are shipped from the factory. Forward launch amplifier attenuator pads, interstage equalizer, and system trim are shipped with every configured node.

Table 11. Optional Accessories

Reverse Amplifier Segmentation Module	Part Number	
Reverse configuration module: Nonsegmented (box of 5)	4018565	
Reverse configuration module: Segmented (box of 5)	4018564	
OIB Redundancy Module	Part Number	
Redundancy jumper module plug-in: Redundant (box of 5)	4018565	
Redundancy jumper module plug-in: Nonredundant (combined) (box of 5)	4018564	
Launch Amplifier Module	Part Number on Module	Part Number for Ordering
GainMaker High Output 4-Port Launch Amplifier 85/105 MHz (GM4P-LA-85105)	800-101535-01	GMN-4PORT
Forward Linear Equalizers	Part Number on Module	Part Number for Ordering
0 dB 1 GHz forward linear equalizer	-	4007228
1.5 dB 1 GHz forward linear equalizer	-	4008778
3.0 dB 1 GHz forward linear equalizer	-	4008779
4.5 dB 1 GHz forward linear equalizer	-	4008780
6.0 dB 1 GHz forward linear equalizer	-	4008781
7.5 dB 1 GHz forward linear equalizer	-	4008782
9.0 dB 1 GHz forward linear equalizer	-	4008783
10.5 dB 1 GHz forward linear equalizer	-	4008784
12.0 dB 1 GHz forward linear equalizer	-	4008785
13.5 dB 1GHz Forward Linear Equalizer	-	4008786
Forward Linear Equalizers	Part Number on Module	Part Number for Ordering
16.5 dB 1 GHz forward linear equalizer	-	4019258
18.0 dB 1 GHz forward linear equalizer	-	4019259
19.5 dB 1 GHz forward linear equalizer	-	4019260
21.0 dB 1 GHz forward linear equalizer	-	4019261

Table 12. Transmitters and Receivers

Optical Transmitters and Receivers (available as part of configuration or separately)	Part Number on Module	Part Number for Ordering
Receivers		
GainMaker node optical receiver with SC/APC connector	4007501	4007671
GainMaker node optical receiver with SC/UPC connector	4007502	4007672

Optical Transmitters and Receivers (available as part of configuration or separately)	Part Number on Module	Part Number for Ordering
GainMaker node optical receiver with FC/APC connector	4007503	4007673
GainMaker node dual redundant receiver with SC/APC connector	4030121	4030121
Analog DFB Transmitters		
DFB optical transmitter: High gain 1310 nm with SC/APC connector	4013906.1310	590938
DFB optical transmitter: High gain 1310 nm with SC/UPC connector	4013907.1310	590939
DFB optical transmitter: High gain 1310 nm with FC/APC connector	4013896.1310	590936
Analog CWDM Transmitters		
CWDM DFB optical transmitter: High gain 1470 nm with SC/APC connector	4013906.1470	4007003
CWDM DFB optical transmitter: High gain 1490 nm with SC/APC connector	4013906.1490	4007004
CWDM DFB optical transmitter: High gain 1510 nm with SC/APC connector	4013906.1510	4007005
CWDM DFB optical transmitter: High gain 1530 nm with SC/APC connector	4013906.1530	4007006
CWDM DFB optical transmitter: High gain 1550 nm with SC/APC connector	4013906.1550	4007007
CWDM DFB optical transmitter: High gain 1570 nm with SC/APC connector	4013906.1570	4007008
CWDM DFB optical transmitter: High gain 1590 nm with SC/APC connector	4013906.1590	4007009
CWDM DFB optical transmitter: High gain 1610 nm with SC/APC connector	4013906.1610	4007010
CWDM DFB optical transmitter: High gain 1470 nm with SC/UPC connector	4013907.1470	4007011
CWDM DFB optical transmitter: High gain 1490 nm with SC/UPC connector	4013907.1490	4007012
CWDM DFB optical transmitter: High gain 1510 nm with SC/UPC connector	4013907.1510	4007013
CWDM DFB optical transmitter: High gain 1530 nm with SC/UPC connector	4013907.1530	4007014
CWDM DFB optical transmitter: High gain 1550 nm with SC/UPC connector	4013907.1550	4007015
CWDM DFB optical transmitter: High gain 1570 nm with SC/UPC connector	4013907.1570	4007016
CWDM DFB optical transmitter: High gain 1590 nm with SC/UPC connector	4013907.1590	4007017
CWDM DFB optical transmitter: High gain 1610 nm with SC/UPC connector	4013907.1610	4007018
CWDM DFB optical transmitter: High gain 1470 nm with FC/APC connector	4013908.1470	4007019
CWDM DFB optical transmitter: High gain 1490 nm with FC/APC connector	4013908.1490	4007020
CWDM DFB optical transmitter: High gain 1510 nm with FC/APC connector	4013908.1510	4007021
CWDM DFB optical transmitter: High gain 1530 nm with FC/APC connector	4013908.1530	4007022
CWDM DFB optical transmitter: High gain 1550 nm with FC/APC connector	4013908.1550	4007023
CWDM DFB optical transmitter: High gain 1570 nm with FC/APC connector	4013908.1570	4007024
CWDM DFB optical transmitter: High gain 1590 nm with FC/APC connector	4013908.1590	4007025
CWDM DFB optical transmitter: High gain 1610 nm with FC/APC connector	4013908.1610	4007026
Analog DWDM Transmitters		
DWDM analog optical transmitter, Ch. 20, 1561.42 nm with SC/APC connector	4023375.20	4023375.20
DWDM analog optical transmitter, Ch. 21, 1560.61 nm with SC/APC connector	4023375.21	4023375.21
DWDM analog optical transmitter, Ch. 22, 1559.79 nm with SC/APC connector	4023375.22	4023375.22
DWDM analog optical transmitter, Ch. 23, 1558.98 nm with SC/APC connector	4023375.23	4023375.23
DWDM analog optical transmitter, Ch. 24, 1558.17 nm with SC/APC connector	4023375.24	4023375.24
DWDM analog optical transmitter, Ch. 25, 1557.36 nm with SC/APC connector	4023375.25	4023375.25
DWDM analog optical transmitter, Ch. 26, 1556.55 nm with SC/APC connector	4023375.26	4023375.26
DWDM analog optical transmitter, Ch. 27, 1555.75 nm with SC/APC connector	4023375.27	4023375.27
DWDM analog optical transmitter, Ch. 28, 1554.94 nm with SC/APC connector	4023375.28	4023375.28
DWDM analog optical transmitter, Ch. 29, 1554.13 nm with SC/APC connector	4023375.29	4023375.29
DWDM analog optical transmitter, Ch. 30, 1553.33 nm with SC/APC connector	4023375.30	4023375.30

Optical Transmitters and Receivers (available as part of configuration or separately)	Part Number on Module	Part Number for Ordering
DWDM analog optical transmitter, Ch. 31, 1552.52 nm with SC/APC connector	4023375.31	4023375.31
DWDM analog optical transmitter, Ch. 32, 1551.72 nm with SC/APC connector	4023375.32	4023375.32
DWDM analog optical transmitter, Ch. 33, 1550.92 nm with SC/APC connector	4023375.33	4023375.33
DWDM analog optical transmitter, Ch. 34, 1550.12 nm with SC/APC connector	4023375.34	4023375.34
DWDM analog optical transmitter, Ch. 35, 1549.32 nm with SC/APC connector	4023375.35	4023375.35
DWDM analog optical transmitter, Ch. 36, 1548.51 nm with SC/APC connector	4023375.36	4023375.36
Analog DWDM Transmitters		
DWDM analog optical transmitter, Ch. 37, 1547.72 nm with SC/APC connector	4023375.37	4023375.37
DWDM analog optical transmitter, Ch. 38, 1546.92 nm with SC/APC connector	4023375.38	4023375.38
DWDM analog optical transmitter, Ch. 39, 1546.12 nm with SC/APC connector	4023375.39	4023375.39
DWDM analog optical transmitter, Ch. 40, 1545.32 nm with SC/APC connector	4023375.40	4023375.40
DWDM analog optical transmitter, Ch. 41, 1544.53 nm with SC/APC connector	4023375.41	4023375.41
DWDM analog optical transmitter, Ch. 42, 1543.73 nm with SC/APC connector	4023375.42	4023375.42
DWDM analog optical transmitter, Ch. 43, 1542.94 nm with SC/APC connector	4023375.43	4023375.43
DWDM analog optical transmitter, Ch. 44, 1542.14 nm with SC/APC connector	4023375.44	4023375.44
DWDM analog optical transmitter, Ch. 45, 1541.35 nm with SC/APC connector	4023375.45	4023375.45
DWDM analog optical transmitter, Ch. 46, 1540.56 nm with SC/APC connector	4023375.46	4023375.46
DWDM analog optical transmitter, Ch. 47, 1539.77 nm with SC/APC connector	4023375.47	4023375.47
DWDM analog optical transmitter, Ch. 48, 1538.98 nm with SC/APC connector	4023375.48	4023375.48
DWDM analog optical transmitter, Ch. 49, 1538.19 nm with SC/APC connector	4023375.49	4023375.49
DWDM analog optical transmitter, Ch. 50, 1537.40 nm with SC/APC connector	4023375.50	4023375.50
DWDM analog optical transmitter, Ch. 51, 1536.61 nm with SC/APC connector	4023375.51	4023375.51
DWDM analog optical transmitter, Ch. 52, 1535.82 nm with SC/APC connector	4023375.52	4023375.52
DWDM analog optical transmitter, Ch. 53, 1535.04 nm with SC/APC connector	4023375.53	4023375.53
DWDM analog optical transmitter, Ch. 54, 1534.25 nm with SC/APC connector	4023375.54	4023375.54
DWDM analog optical transmitter, Ch. 55, 1533.47 nm with SC/APC connector	4023375.55	4023375.55
DWDM analog optical transmitter, Ch. 56, 1532.68 nm with SC/APC connector	4023375.56	4023375.56
DWDM analog optical transmitter, Ch. 57, 1531.90 nm with SC/APC connector	4023375.57	4023375.57
DWDM analog optical transmitter, Ch. 58, 1531.12 nm with SC/APC connector	4023375.58	4023375.58
DWDM analog optical transmitter, Ch. 59, 1530.33 nm with SC/APC connector	4023375.59	4023375.59

Table 13. Cisco GM EDR CWDM Reverse Optical Transmitters

GM EDR CWDM Reverse Optical Transmitter and Optical Pluggable Modules (OPMs)	Part Number Module	Part Number for Ordering
Digital 1:1 EDR CWDM Transmitters		
EDR GM1185 transmitter module	800-4042187-01	4042881
EDR 1:1 transmitter OPM CWDM-1270	10-1022072-01	4042868.1270
EDR 1:1 transmitter OPM CWDM-1290	10-1022073-01	4042868.1290
EDR 1:1 transmitter OPM CWDM-1310	10-1022074-01	4042868.1310
EDR 1:1 transmitter OPM CWDM-1330	10-1022075-01	4042868.1330
EDR 1:1 transmitter OPM CWDM-1350	10-1022076-01	4042868.1350
EDR 1:1 transmitter OPM CWDM-1370	10-1022077-01	4042868.1370
EDR 1:1 transmitter OPM CWDM-1390	10-1022078-01	4042868.1390
EDR 1:1 transmitter OPM CWDM-1410	10-1022079-01	4042868.1410

GM EDR CWDM Reverse Optical Transmitter and Optical Pluggable Modules (OPMs)	Part Number Module	Part Number for Ordering
EDR 1:1 transmitter OPM CWDM-1430	10-1022080-01	4042868.1430
EDR 1:1 transmitter OPM CWDM-1450	10-1022081-01	4042868.1450
EDR 1:1 transmitter OPM CWDM-1470	10-1022082-01	4042868.1470
EDR 1:1 transmitter OPM CWDM-1490	10-1022083-01	4042868.1490
EDR 1:1 transmitter OPM CWDM-1510	10-1022084-01	4042868.1510
EDR 1:1 transmitter OPM CWDM-1530	10-1022085-01	4042868.1530
EDR 1:1 transmitter OPM CWDM-1550	10-1022086-01	4042868.1550
EDR 1:1 transmitter OPM CWDM-1570	10-1022087-01	4042868.1570
EDR 1:1 transmitter OPM CWDM-1590	10-1022088-01	4042868.1590
EDR 1:1 transmitter OPM CWDM-1610	10-1022089-01	4042868.1610
Digital 2:1 EDR CWDM Transmitters		
EDR GM2185 transmitter module	800-4041274-01	4042885
EDR 2:1 transmitter OPM CWDM-1270	10-1022058-01	4042871.1270
EDR 2:1 transmitter OPM CWDM-1290	10-1022059-01	4042871.1290
EDR 2:1 transmitter OPM CWDM-1310	10-1022060-01	4042871.1310
EDR 2:1 transmitter OPM CWDM-1330	10-1022061-01	4042871.1330
EDR 2:1 transmitter OPM CWDM-1350	10-1022062-01	4042871.1350
EDR 2:1 transmitter OPM CWDM-1370	10-1022008-01	4042871.1370
EDR 2:1 transmitter OPM CWDM-1390	10-1022063-01	4042871.1390
EDR 2:1 transmitter OPM CWDM-1410	10-1022064-01	4042871.1410
EDR 2:1 transmitter OPM CWDM-1430	10-1022065-01	4042871.1430
EDR 2:1 transmitter OPM CWDM-1450	10-1022066-01	4042871.1450
EDR 2:1 transmitter OPM CWDM-1470	10-1022067-01	4042871.1470
EDR 2:1 transmitter OPM CWDM-1490	10-1022009-01	4042871.1490
EDR 2:1 transmitter OPM CWDM-1510	10-1022010-01	4042871.1510
EDR 2:1 transmitter OPM CWDM-1530	10-1022068-01	4042871.1530
EDR 2:1 transmitter OPM CWDM-1550	10-1022011-01	4042871.1550
EDR 2:1 transmitter OPM CWDM-1570	10-1022069-01	4042871.1570
EDR 2:1 transmitter OPM CWDM-1590	10-1022012-01	4042871.1590
EDR 2:1 transmitter OPM CWDM-1610	10-1022070-01	4042871.1610

Table 14. Cisco GM EDR DWDM Reverse Optical Transmitters

GM EDR DWDM Reverse Optical Transmitter Optical Pluggable Modules (OPMs)	Part Number on Transmitter Module	Part Number for Ordering
Digital 1:1 EDR DWDM Transmitter OPMs		
EDR GM1185 transmitter module	800-4042187-01	4042881
EDR 1:1 transmitter OPM DWDM-17	10-1022090-01	4042869.17
EDR 1:1 transmitter OPM DWDM-18	10-1022091-01	4042869.18
EDR 1:1 transmitter OPM DWDM-19	10-1022092-01	4042869.19
EDR 1:1 transmitter OPM DWDM-20	10-1022093-01	4042869.20
EDR 1:1 transmitter OPM DWDM-21	10-1022094-01	4042869.21
EDR 1:1 transmitter OPM DWDM-22	10-1022095-01	4042869.22
EDR 1:1 transmitter OPM DWDM-23	10-1022096-01	4042869.23
EDR 1:1 transmitter OPM DWDM-24	10-1022097-01	4042869.24
EDR 1:1 transmitter OPM DWDM-25	10-1022098-01	4042869.25

GM EDR DWDM Reverse Optical Transmitter Optical Pluggable Modules (OPMs)	Part Number on Transmitter Module	Part Number for Ordering
EDR 1:1 transmitter OPM DWDM-26	10-1022099-01	4042869.26
EDR 1:1 transmitter OPM DWDM-27	10-1022100-01	4042869.27
EDR 1:1 transmitter OPM DWDM-28	10-1022101-01	4042869.28
EDR 1:1 transmitter OPM DWDM-29	10-1022102-01	4042869.29
EDR 1:1 transmitter OPM DWDM-30	10-1022103-01	4042869.30
EDR 1:1 transmitter OPM DWDM-31	10-1022104-01	4042869.31
EDR 1:1 transmitter OPM DWDM-32	10-1022105-01	4042869.32
EDR 1:1 transmitter OPM DWDM-33	10-1022106-01	4042869.33
EDR 1:1 transmitter OPM DWDM-34	10-1022107-01	4042869.34
EDR 1:1 transmitter OPM DWDM-35	10-1022108-01	4042869.35
EDR 1:1 transmitter OPM DWDM-36	10-1022109-01	4042869.36
EDR 1:1 transmitter OPM DWDM-37	10-1022110-01	4042869.37
EDR 1:1 transmitter OPM DWDM-38	10-1022111-01	4042869.38
EDR 1:1 transmitter OPM DWDM-39	10-1022112-01	4042869.39
EDR 1:1 transmitter OPM DWDM-40	10-1022113-01	4042869.40
EDR 1:1 transmitter OPM DWDM-41	10-1022114-01	4042869.41
EDR 1:1 transmitter OPM DWDM-42	10-1022115-01	4042869.42
EDR 1:1 transmitter OPM DWDM-43	10-1022116-01	4042869.43
EDR 1:1 transmitter OPM DWDM-44	10-1022117-01	4042869.44
EDR 1:1 transmitter OPM DWDM-45	10-1022118-01	4042869.45
EDR 1:1 transmitter OPM DWDM-46	10-1022119-01	4042869.46
EDR 1:1 transmitter OPM DWDM-47	10-1022120-01	4042869.47
EDR 1:1 transmitter OPM DWDM-48	10-1022121-01	4042869.48
EDR 1:1 transmitter OPM DWDM-49	10-1022122-01	4042869.49
EDR 1:1 transmitter OPM DWDM-50	10-1022123-01	4042869.50
EDR 1:1 transmitter OPM DWDM-51	10-1022124-01	4042869.51
EDR 1:1 transmitter OPM DWDM-52	10-1022125-01	4042869.52
EDR 1:1 transmitter OPM DWDM-53	10-1022126-01	4042869.53
EDR 1:1 transmitter OPM DWDM-54	10-1022127-01	4042869.54
EDR 1:1 transmitter OPM DWDM-55	10-1022128-01	4042869.55
EDR 1:1 transmitter OPM DWDM-56	10-1022129-01	4042869.56
EDR 1:1 transmitter OPM DWDM-57	10-1022130-01	4042869.57
EDR 1:1 transmitter OPM DWDM-58	10-1022131-01	4042869.58
EDR 1:1 transmitter OPM DWDM-59	10-1022132-01	4042869.59
EDR 1:1 transmitter OPM DWDM-60	10-1022133-01	4042869.60
EDR 1:1 transmitter OPM DWDM-61	10-1022134-01	4042869.61
Digital 2:1 EDR DWDM Transmitter OPMs		
EDR GM2185 transmitter module	800-4041274-01	4042885
EDR 2:1 transmitter OPM DWDM-17	10-1022013-01	4042872.17
EDR 2:1 transmitter OPM DWDM-18	10-1022014-01	4042872.18
EDR 2:1 transmitter OPM DWDM-19	10-1022015-01	4042872.19
EDR 2:1 transmitter OPM DWDM-20	10-1022016-01	4042872.20
EDR 2:1 transmitter OPM DWDM-21	10-1022017-01	4042872.21

GM EDR DWDM Reverse Optical Transmitter Optical Pluggable Modules (OPMs)	Part Number on Transmitter Module	Part Number for Ordering
EDR 2:1 transmitter OPM DWDM-22	10-1022018-01	4042872.22
EDR 2:1 transmitter OPM DWDM-23	10-1022019-01	4042872.23
EDR 2:1 transmitter OPM DWDM-24	10-1022020-01	4042872.24
EDR 2:1 transmitter OPM DWDM-25	10-1022021-01	4042872.25
EDR 2:1 transmitter OPM DWDM-26	10-1022022-01	4042872.26
EDR 2:1 transmitter OPM DWDM-27	10-1022023-01	4042872.27
EDR 2:1 transmitter OPM DWDM-28	10-1022024-01	4042872.28
EDR 2:1 transmitter OPM DWDM-29	10-1022025-01	4042872.29
EDR 2:1 transmitter OPM DWDM-30	10-1022026-01	4042872.30
EDR 2:1 transmitter OPM DWDM-31	10-1022027-01	4042872.31
EDR 2:1 transmitter OPM DWDM-32	10-1022028-01	4042872.32
EDR 2:1 transmitter OPM DWDM-33	10-1022029-01	4042872.33
EDR 2:1 transmitter OPM DWDM-34	10-1022030-01	4042872.34
EDR 2:1 transmitter OPM DWDM-35	10-1022031-01	4042872.35
EDR 2:1 transmitter OPM DWDM-36	10-1022032-01	4042872.36
EDR 2:1 transmitter OPM DWDM-37	10-1022033-01	4042872.37
EDR 2:1 transmitter OPM DWDM-38	10-1022034-01	4042872.38
EDR 2:1 transmitter OPM DWDM-39	10-1022035-01	4042872.39
EDR 2:1 transmitter OPM DWDM-40	10-1022036-01	4042872.40
EDR 2:1 transmitter OPM DWDM-41	10-1022037-01	4042872.41
EDR 2:1 transmitter OPM DWDM-42	10-1022038-01	4042872.42
EDR 2:1 transmitter OPM DWDM-43	10-1022039-01	4042872.43
EDR 2:1 transmitter OPM DWDM-44	10-1022040-01	4042872.44
EDR 2:1 transmitter OPM DWDM-45	10-1022041-01	4042872.45
EDR 2:1 transmitter OPM DWDM-46	10-1022042-01	4042872.46
EDR 2:1 transmitter OPM DWDM-47	10-1022043-01	4042872.47
EDR 2:1 transmitter OPM DWDM-48	10-1022044-01	4042872.48
EDR 2:1 transmitter OPM DWDM-49	10-1022045-01	4042872.49
EDR 2:1 transmitter OPM DWDM-50	10-1022046-01	4042872.50
EDR 2:1 transmitter OPM DWDM-51	10-1022047-01	4042872.51
EDR 2:1 transmitter OPM DWDM-52	10-1022048-01	4042872.52
EDR 2:1 transmitter OPM DWDM-53	10-1022049-01	4042872.53
EDR 2:1 transmitter OPM DWDM-54	10-1022050-01	4042872.54
EDR 2:1 transmitter OPM DWDM-55	10-1022051-01	4042872.55
EDR 2:1 transmitter OPM DWDM-56	10-1022052-01	4042872.56
EDR 2:1 transmitter OPM DWDM-57	10-1022053-01	4042872.57
EDR 2:1 transmitter OPM DWDM-58	10-1022054-01	4042872.58
EDR 2:1 transmitter OPM DWDM-59	10-1022055-01	4042872.59
EDR 2:1 transmitter OPM DWDM-60	10-1022056-01	4042872.60
EDR 2:1 transmitter OPM DWDM-61	10-1022057-01	4042872.61

Table 15. Related Equipment

Related Equipment (available as part of configuration or separately)	Part Number on Module	Part Number for Ordering
High Output 4-Port GainMaker Node: Standard DC power supply 40-90 VAC	4027978	4027962
High Output 4-Port GainMaker Node Status Monitoring Transponder: See Transponder for GainMaker Optoelectronic Node data sheet, part number 7000087	4027979	4027963

Cisco Systems, Inc.
1 800 722-2009 or 678 277-1120
<http://www.cisco.com>



Americas Headquarters
Cisco Systems, Inc.
San Jose, CA

Asia Pacific Headquarters
Cisco Systems (USA) Pte. Ltd.
Singapore

Europe Headquarters
Cisco Systems International BV Amsterdam,
The Netherlands

Cisco has more than 200 offices worldwide. Addresses, phone numbers, and fax numbers are listed on the Cisco Website at www.cisco.com/go/offices.

Cisco and the Cisco logo are trademarks or registered trademarks of Cisco and/or its affiliates in the U.S. and other countries. To view a list of Cisco trademarks, go to this URL: www.cisco.com/go/trademarks. Third party trademarks mentioned are the property of their respective owners. The use of the word partner does not imply a partnership relationship between Cisco and any other company. (1110R)